

DCA DEHUMIDIFIER
CORPORATION
OF AMERICA

Value Driven Quality, Built Here

R-410A REFRIGERANT SERIES

SWIMMING POOL DEHUMIDIFIER OWNER'S MANUAL

INSTALLATION • OPERATION
MAINTENANCE

IMPORTANT: This manual contains general information regarding pool room dehumidification. It includes general building construction considerations, dehumidifier installation guidelines and tips that are considered common knowledge in this industry.

It cannot be considered an all-inclusive manual that will cover every aspect of the design and construction of all indoor pool rooms. Contact an architect or building contractor that is familiar with indoor pool rooms for your specific project.

Specific information for your dehumidifier is on the unit's identification plate and decal located on the dehumidifier cabinet.

Additional information and diagrams can be found on our website:

www.dehumidifiercorp.com

THIS MANUAL MUST BE READ AND UNDERSTOOD BY A QUALIFIED PERSON OR PERSONS BEFORE INSTALLATION

CONTENTS

Introduction	2
Warranty	3, 4
Legend of Typical Installation	5
Location/Mounting	6
Duct Work And Air Distribution Installation & Design	7, 8
Condensate Drain Plumbing Connection	9
Remote Condenser Installation	10
Charging Instructions	10
Electrical Connections, Controls: Location & Mounting	11
Pool Water Heating and Chemicals	12
Minimum Factory Start-Up Requirements	13
Air Flow Balancing	14, 15
Unit Start-Up Procedure	16
(Use this procedure to fill out the Start-up Report and Warranty Registration)	
Maintenance And Service Procedure	16
Operating with Remote Condenser & Operating with Water Heating Condenser	17
Reheat Mode & Cooling Mode Diagrams	18
Water Heating Mode Diagrams, Set Point Readjustment & Humidity Set Point Readjustment	19
Temperature Set Point Readjustment	20
Troubleshooting Guide - Owner/User	21
Troubleshooting Guide - Service Technician	22-24
Contact Information	25

Please call DCA with any questions; we will need to know the model and serial numbers for the dehumidifier and remote condenser

INTRODUCTION

DCA Series

Congratulations! You have purchased the finest equipment available to control the damaging humidity associated with indoor pools and spa areas.

DCA dehumidifiers are precision engineered products, specifically designed to control the conditions in your indoor pool room to obtain maximum performance and energy savings.

Your DCA dehumidifier has been carefully assembled and tested at our factory by our trained personnel. Only Skilled, Trained and Qualified Personnel may install and service your DCA equipment.

DCA cannot possibly anticipate every possible circumstance that might involve a hazard. The warnings in this manual and on tags and decals affixed to the equipment are, therefore, not all-inclusive. If you use a procedure, work method or operating technique not specifically recommended by DCA, you must satisfy yourself that it is safe for you and others.

CAUTION

Serious injury, property damage and death can result from unqualified personnel installing and servicing this equipment. High pressure refrigerants and high electrical voltage are present.

IMPORTANT

Your DCA dehumidifier is one of several essential components that are necessary in your pool room for complete environmental control. The following areas must be incorporated in your pool room by you, your contractor, engineer and architect.

- HUMIDITY CONTROL
- DUCT DESIGN
- AIR DISTRIBUTION OVER EXTERIOR GLASS AND SKYLIGHTS
- VENTILATION
- BUILDING CONSTRUCTION
- POOL WATER CHEMISTRY
- ADEQUATE POOL ROOM VAPOR BARRIER
- PROPER WALL & CEILING INSULATION
- LOW "E" GLASS & SKYLIGHTS
- PROPER STORAGE OF POOL & SPA WATER CHEMICALS

A pool room dehumidifying system will not provide desired comfort and building protection unless these areas are addressed.

Important information about each of these are included in this manual. It is the responsibility of the owner along with the contractor, engineer and architect to ensure that careful consideration be given to all of these areas of pool room environment control.

A DCA dehumidification system can handle all of your moisture removal needs, and in many cases, your heating and cooling requirements as well.

Dehumidification is accomplished by moving room air through the dehumidifying coil, lowering the air temperature below its dew point. Moisture will condense on this coil thus removing a large portion of the moisture from the air. The heat recovered by the above mentioned process, known as latent heat, and the electrical consumption of the compressor is delivered by the reheat condenser coil. The air leaving the evaporator coil enters the reheat condenser coil and picks up the available heat and exits the dehumidifier as warm dry air.

With the addition of an air cooled remote condenser, a portion of the room cooling can be achieved during the warm months. If the room temperature should rise above the preset condition, the system will switch from delivering warm dry air to delivering cool dry air automatically. As stated above, the DCA system will control moisture and in some cases heat and cool the pool room enclosures.

Proper installation, by qualified personnel, of the dehumidifying system takes careful analysis and planning and is very important in achieving the total desired results. Even though a pool room dehumidifier can provide supplemental room heating, every pool room needs a primary room heating source that is sized to handle the total room heating requirement plus any outdoor air that may be needed. This primary pool room heating source must be sized independent of any room heating that may be derived from the warm pool water.

UNPACKING & INSPECTION

All DCA Systems are completely factory tested to ensure proper operation before shipment. Check for shipping damage both internal (concealed) and external.

NOTATION MUST BE MADE ON CARRIERS FREIGHT BILL OF LADING TO INSURE PROMPT FREIGHT DAMAGE CLAIMS PROCESSING.

Claims for freight damage or shortages must be filed within 5 days of acceptance of equipment with the delivering freight carrier. All Freight Claims must be resolved with the delivering freight carrier. The factory cannot be of any help after equipment is signed for and delivered.

DCA SERIES HUMIDITY CONTROL SYSTEMS LIMITED PRODUCT WARRANTY

MODELS

DCA 650A • DCA 650AWH • DCA 900A • DCA 900AWH • DCA 1500A • DCA 1500AWH • DCA 2000A
DCA 2000AWH • DCA 2500A • DCA 2500AWH • DCA 3000A • DCA 3000AWH • DCA 3300A
DCA 3300AWH • DCA 3500A • DCA3500AWH • DCA 3600A • DCA 3600AWH • DCA 4100A • DCA 4100AWH
DCA 4400A • DCA 4400AWH • DCA 4800A • DCA 4800AWH • DCA 5500A • DCA 5500AWH • DCA6500A
DCA6500AWH • DCA 7000A • DCA 7000AWH • DCA 8000A • DCA 9000A • DCA 11000A • DCA 14000A

This certificate is our warranty to you. Please ensure that you or your installing dealer understand this warranty. Dehumidifier Corporation of America, Inc. applies this limited warranty on all units of its manufacture to be free from defects in material and workmanship under normal intended use and service when units remain at original installation site and are correctly installed and operated according to printed instructions and in compliance with all local installation and building codes and acceptable trade practices.

This Limited Warranty is void unless upon start-up of the unit the "Start-up Report and Warranty Registration" is completed and received at the factory within 30 days of start-up. This will also register the compressor warranty with the compressor manufacturer.

The company shall, unless specified herein, during the first three years after date of initial installation replace any part supplied by DCA that fails because of a defect in workmanship or material.

All controls, supplied by DCA, as part of a dehumidification system will carry a one (1) year warranty from date of start up as validated by the return of the start up report returned to DCA no later than 30 days after the start up date.

All freon compressors and all other parts excluding return air filters and blower belts, carry a three year parts warranty (an optional 5 year extended compressor warranty can be purchased at the time of the sale). DCA will furnish a replacement compressor, upon a compressor failure, shipped freight collect. Subsequent

compressor replacements, on a no cost basis, will be at the discretion of DCA and will be handled on a case by case basis. Normally after the second compressor fails, within the 3 year warranty period (or the 5 year extended compressor warranty period), a problem exists in the installation, maintenance or causes beyond the control of DCA such as and not limited to power fluctuations or lightning strikes. The cause of failure must be determined before any action is taken by DCA.

Refrigeration coils, as part of the DCA dehumidification system, carry a five year warranty. DCA will furnish a replacement refrigeration coil, upon a coil failure, shipped freight collect. Subsequent coil replacements, on a no cost basis, will be at the discretion of DCA and handled on a case by case basis. Normally after the second coil fails within the 5 year warranty period, a problem exists in the installation, maintenance or causes beyond the control of DCA. Premature coil fin erosion normally signals that chemicals are stored in the mechanical room, with the dehumidifier, or contaminated return air is present and must be corrected before any action is taken by DCA.

The definition of a defective dehumidifier part will be as follows. In the case of a defective part, that falls in the definition of its warranty period, the replacement part will be shipped from the factory promptly with the customer being billed immediately via COD, a valid credit card via an existing open account with DCA. The defective part will be shipped back to the DCA factory with all associated costs being paid by customer.

OWNER'S MANUAL

Upon return, the defective part will be examined for cause of failure. If it is determined that the part was found to be defective in materials or workmanship, DCA will immediately credit the customer back via the same initial method of payment. All the associated freight costs will be paid for by the contractor or owner. If DCA has determined that the returned part was subjected to miss use or alteration, warranty will be denied.

DCA will supply a new or replacement part free. All in-warranty replacement parts will be warranted for the unused portion of that component's warranty as established herein. Freight charges on warranty replacements are the responsibility of the owner. Any charges associated with labor, material, refrigerant or any other charges with the repair will be the responsibility of the owner.

There is no warranty for any of the following:

- (1) Alteration, misuse, negligence, accident, floods, or Acts of God.
- (2) If operation of the unit is contrary to the company or manufacturer's recommendation or
- (3) if any unit has been altered or repaired by improper matching of the unit or units components in any way outside of the factory, so as to affect its stability or performance in our judgement.
- (4) Any damages caused by failing to provide maintenance and service to the unit.
- (5) Any Labor cost incurred in diagnosing, erecting or disconnecting, or any damage or repairs required as a result of faulty installation or replacing any parts or any parts used in connection with normal maintenance, such as filters or belts.
- (6) Fuel or electricity costs or any increase in electricity of fuel costs whatsoever including any additional or unusual use of supplemental heat.
- (7) Actions or negligence of the installer or servicer of the unit that result in losses or damage of any kind including those due to inadequate:
 - (A) Sizing of the unit to the area.
 - (B) Air Distribution.
 - (C) Duct Work and
 - (D) Poorly insulated or loosely constructed rooms.
 - (E) Excessive glass or skylights on outside cold walls.
 - (F) Excessive infiltration.

(G) Power supply.

(H) Others.

THIS WARRANTY DOES NOT INCLUDE SERVICE OR LABOR CHARGES CONNECTED WITH THE DETERMINATION OR REPLACEMENT OF DEFECTIVE PARTS. ALL LABOR CHARGES ARE THE RESPONSIBILITY OF THE INSTALLING CONTRACTOR FOR THE LENGTH OF HIS WARRANTY, IF ANY, AND THEREAFTER THE OWNER.

Sheet metal expendable supplies such as refrigerants, solder, fluxes, and repairable coils are not included as part of this warranty. Buyer's sole and exclusive remedy with respect to the product are provided in this warranty and the expressed warranties contained herein are in lieu of all other warranties.

IMPLIED WARRANTIES INCLUDING WARRANTIES OF MERCHANTABILITY OR FITNESS FOR A PARTICULAR USE OR PURPOSE, SHALL ONLY LAST FOR ONE YEAR AFTER DATE OF ORIGINAL INSTALLATION.

Buyer assumes all other liability for any loss, damage or injury to persons or property, arising out of, connected with or resulting from the use of the Company's Products, either alone or in combination with other products. In no event shall the company be liable for any other damages, either direct, incidental, consequential, or otherwise. Some states do not allow limitations on how long an implied warranty lasts or the exclusions of consequential or incidental damages, so the above limitations and exclusions may not apply. This warranty gives you specific legal rights and you also may have other rights which vary from state to state.

ALL CLAIMS RELATING TO OR ARISING OUT OF THE OPERATION OF THIS PRODUCT ARE SUBJECT TO BINDING ARBITRATION UNDER THE AUSPICES AND RULES OF THE AMERICAN ARBITRATION ASSOCIATION.

OWNER'S MANUAL

LEGEND

1. DCA Pool Water Heating Assist Dehumidifier
2. Optional Remote Condenser (A/C) (page 10)
 - A. Air Cooled Model Shown
 - B. Water Cooled Model Available
 - C. Cooling Tower Loop Available
 - D. Geothermal Loop Available
3. Main Pool Circulating Pump (By Others)
4. Auxiliary Pool Water Heater (By Others)
5. Pool Water Filter
6. Auxiliary Pool Water Pump (By Others) Supplies Pool Water To Dehumidifier Water Heater
7. Make-up Air Assembly (By Others)
 - A. Air Filter
 - B. Damper Control and Timer
 - C. Outside Air Pre-Heater
 - D. Bird Screen & Termination
8. Mounting feet and vibration isolators by others. (page 6)
9. Electric/Gas/Hot Water Add On Duct Heater (By Others)
10. Vibration Isolator Duct Connector (By Others)
11. Flow Control, Flow Meter and Shut-Off Valve (By Others)
12. P-Trap and Condensate Return (By Others) (page 9)
13. Air Vent (By Others)
14. Electrical Access Door
15. Dehumidifier Component Access Doors
16. Balancing valve.
17. Pool Room Exhaust Fan. (Not Illustrated; By Others)

Note: This is a generic drawing. Location of piping and components may vary from unit to unit.

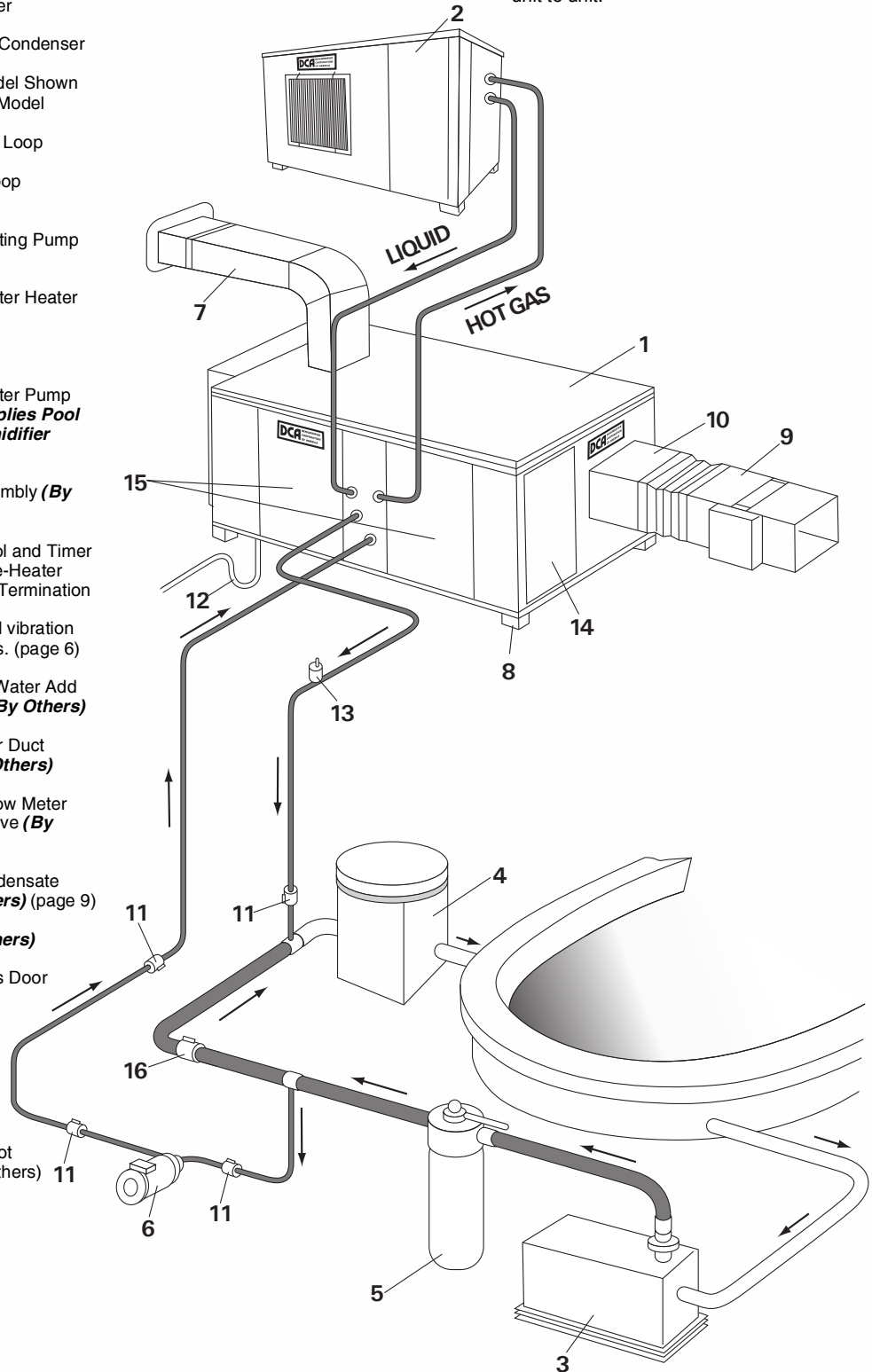

LOCATION AND MOUNTING

Unless authorized by DCA all units must be installed in equipment rooms and areas that do not fall below 45° F.

Considerations must be made for service access, electrical requirements, duct work and filter access on all units.

NOTE:

CLEARANCE OF 18" TO 24" IS RECOMMENDED ON TOP, BOTTOM AND ALL SIDES FOR SERVICE OF COMPONENTS SUCH AS FILTERS, MOTORS, BELTS AND REFRIGERATION COMPONENTS. ADDITIONAL CLEARANCE MUST BE ALLOWED FOR THE ELECTRICAL ENCLOSURE AS SPECIFIED BY NEC AND LOCAL CODES.

Units may be field installed by placing them on mounting platforms made of materials of sufficient strength to prevent vibrations and sound resonance.

Install sound and vibration eliminators such as anti-vibration pads, canvas duct connectors (field supplied) or other approved methods to isolate the unit from the supportive structure and ductwork. (See figure at right).

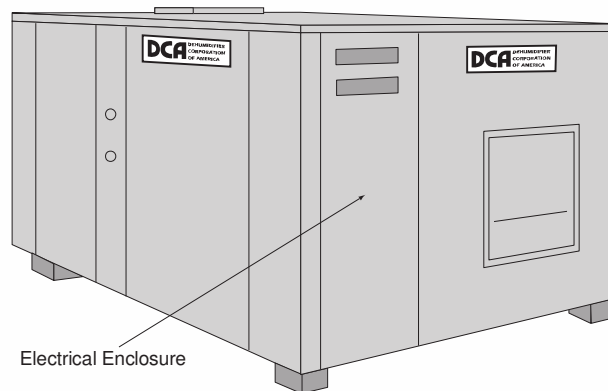

Electrical Enclosure

Typical Floor Installation

DUCT WORK AND DISTRIBUTION

Proper air distribution is important in an indoor swimming pool room to prevent condensation on windows, and to improve comfort. The quantity of supply air and the velocity of air from the air distribution system should be of sufficient volume to cover all areas of exterior glass, skylights and patio doors with warm, dry air. This is the only remedy in an attempt to keep exterior glass and skylights from moisture and condensation build-up.

IMPORTANT

ALL DUCT DESIGN AND CONSTRUCTION MUST CONFORM WITH THE LATEST **ASHRAE** AND **SMACNA** LOW VELOCITY DUCT STANDARDS

Refer to the page 14 for air volumes and static pressure specifications of the units. Special attention should be given to the following areas to achieve desired results.

1. Supply air from registers should be directed on outside walls and away from the swimming and spa surfaces. Make sure that all outside walls and the entire surface of exterior glass are covered with supply air.
2. The return air inlet should be located high in the room as possible to prevent air stratification. **Make sure that supply air does not short cycle back to the return inlet.** If the dehumidifier is installed without return air duct, provide a minimum of 4 feet of clearance between the unit and the closest obstruction.
3. The recommended duct materials are standard galvanized sheet metal, aluminum or PVC pipe. All elbows should be of low restriction. Ductwork must be insulated on the

outside if located in areas that are unconditioned to prevent condensation and heat loss. Use flexible duct connectors to attach ductwork to the DCA unit to eliminate any vibrations.

4. Grilles, registers and diffusers should be selected on the basis of low noise criteria (NC) noise levels, CFM requirements as well as air diffusion patterns to cover cold surfaces with conditioned air. Choose hardware resistant to deterioration from the presence of chemicals in the pool room atmosphere. 100 CFM per register is recommended.
5. Ceiling fans can be used, local codes permitting, to insure more complete air circulation. Make sure that air is directed upward to avoid drafts that can result in increased water evaporation.
6. A minimum of 4' of duct must be attached to the dehumidifier supply outlet to ensure proper air-flow.
7. ASHRAE recommends that surfaces such as windows and outside doors receive between 3 and 5 CFM of dehumidifier air per square foot to prevent condensation.

IMPORTANT

POOR DUCT DESIGN AND INSTALLATION WILL RESULT IN UNEVEN AIR DISTRIBUTION, POOR OPERATING PERFORMANCE, REDUCED MOISTURE REMOVAL, MOISTURE FORMATION ON EXTERIOR GLASS AND SKYLIGHTS AND INCREASED OPERATING COSTS.

Typical Duct Installation

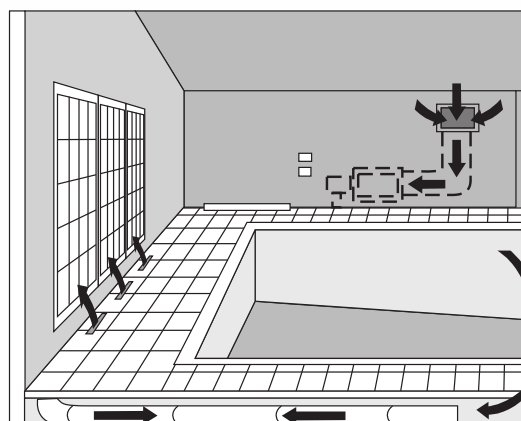
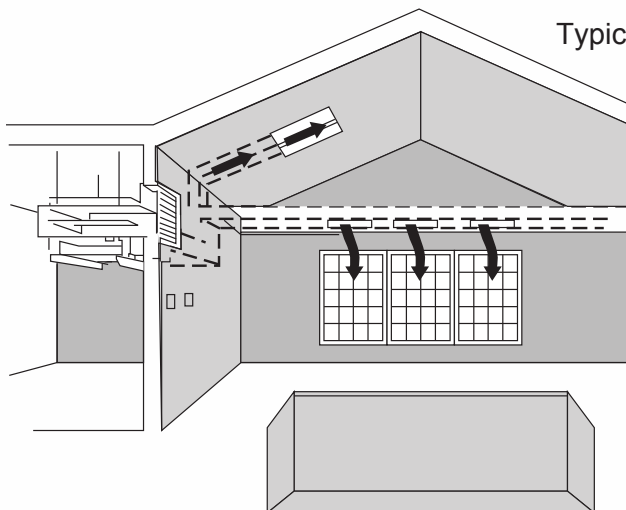

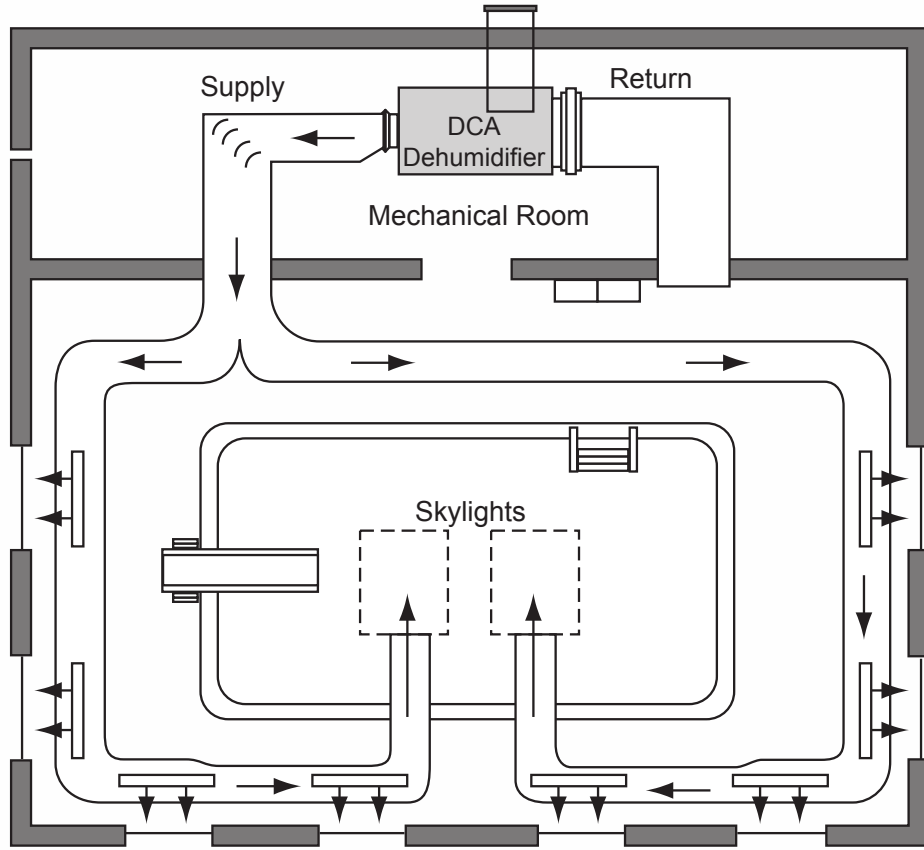

TYPICAL DUCTED POOL ROOM INSTALLATION

All duct work shall meet ASHRAE and SMACNA design standards.

SMACNA DUCT DESIGNS

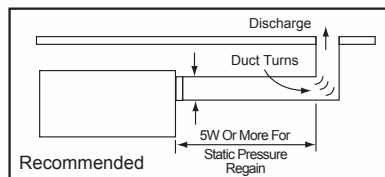
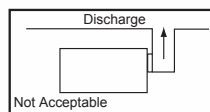
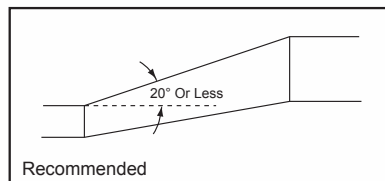
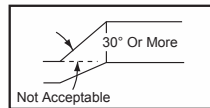
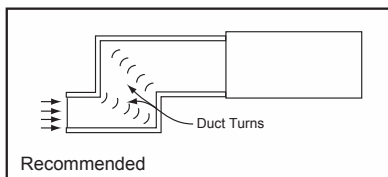
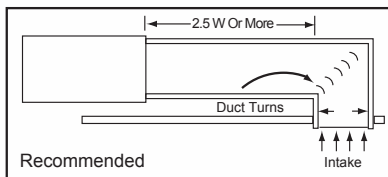
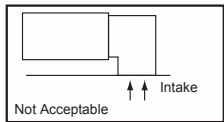

**CONDENSATE DRAIN/
PLUMBING CONNECTION**

Check all local codes and by-laws for approved methods of condensate water disposal. If codes permit, condensate water may be returned back to the swimming pool by gravity drainage to the nearest skimmer or surge tank (if equipped). If codes do not permit condensate water to be returned back to the swimming pool, an approved drain must be provided for proper disposal.

If codes permit, schedule 40 PVC pipe is recommended for drainage pipe. Slope the condensate drain line with a minimum of 1/4 inch per foot. A P-trap is recommended and filled with water to prevent air from entering the unit to assure proper drainage of the condensate.

A condensate pump is required (field supplied) at installations where the unit is located below the pool water surface or drain access. If a pump is used it must have sufficient pump head to overcome vertical lift and water pressure if pumped into a pressurized pipeline. When connecting to a pressurized pipeline a check valve and solenoid should be used. Do not connect the condensate drain to a pipe with negative pressure. When the dehumidifier is installed outdoors, the drain line must be heat taped and insulated to avoid freezing.

Refer to the illustration on page 5.

OWNER'S MANUAL

THE DCA DEHUMIDIFIER IS A FLOODING HEAD PRESSURE CONTROL SYSTEM

It comes complete with all that is necessary for remote condenser operation pre-installed and tested i.e. liquid receiver, 3-way valve etc. Refer to the decal on the dehumidifier for the amount of additional refrigerant R410A to be weighed in, when a corresponding remote condenser is added. Refrigerant lines (field supplied) should not exceed 50- feet in length. Contact DCA when longer lengths are needed.

Provide at least 5 feet of clearance in front of and top of unit for proper unit operation.

IMPORTANT

The outdoor remote condenser must be installed above or at the same level as the dehumidifier. When installing the remote condenser below the dehumidifier more than eight feet, the factory must be consulted.

Hot gas and liquid line sizes that are stated on the unit and in the installation manual must be adhered to. The length of run of these lines must be 50 feet or less. Contact factory for runs over 50 feet.

ATTENTION INSTALLERS

Only trained, qualified personnel should install or service DCA equipment. Serious injury, death and property damage can result from improper installation/service of this equipment. High voltage electrical components and refrigerant under pressure are present.

REFRIGERANT PIPING OF REMOTE CONDENSER

Refrigerant piping (supplied by others) must be dehydrated copper. Standard refrigerant practices must be used when a remote condenser is installed. Both outgoing and incoming refrigerant lines must be insulated inside of the building. Hot gas lines shall have traps installed every 15 feet of vertical lift. The remote condenser is shipped with a nitrogen holding charge. Remove this charge at the access ports provided before attempting to evacuate the system. Refer to the chart to determine the correct remote condenser line size required.

Service valves on the main unit are located in the blower

DEHUMIDIFIER MODEL#	PIPE SIZE	
	SUPPLY	RETURN
DCA 650A	5/8" OD	3/8" OD
DCA 900A	5/8" OD	3/8" OD
DCA 1500A	3/4" OD	1/2" OD
DCA 2000A	3/4" OD	1/2" OD
DCA 2500A	7/8" OD	1/2" OD
DCA 3000A	7/8" OD	5/8" OD
DCA 3300A	7/8" OD	5/8" OD
DCA 3600A	1 1/8" OD	5/8" OD
DCA 4100A	1 1/8" OD	5/8" OD
DCA 4400A	1 1/8" OD	5/8" OD
DCA 4800A	1 1/8" OD	3/4" OD
DCA 5500A	1 1/8" OD	7/8" OD

DCA 6500A	1 1/8" OD	7/8" OD
DCA 7000A	1 3/8" OD	7/8" OD
DCA 8000A – A	1 1/8" OD	5/8" OD
– B	1 1/8" OD	5/8" OD
DCA 9000A – A	1 1/8" OD	3/4" OD
– B	1 1/8" OD	3/4" OD
DCA 11000A – A	1 1/8" OD	7/8" OD
– B	1 1/8" OD	7/8" OD
DCA 14000A – A	1 3/8" OD	7/8" OD
– B	1 3/8" OD	7/8" OD

compartment. Keep these service valves closed (front seated) during all soldering, evacuation and refrigerant charging.

When installing the line set, make sure that all solder joints are clean, oil free and absent of any foreign material. Insert the line into the valve until the line bottoms out in the valve. Complete the soldering process. Pressurize the line set with an inert gas to determine if any leaks are present. Repair the leaks, if any, and evacuate the line set and remote condenser down to 500 microns. Once the evacuation procedure has been completed, pressurize the system with one pound of liquid R-410A, wait 5 minutes and then check with an electronic leak detector.

CHARGING INSTRUCTIONS

Because R-410A is a zeotropic refrigerant, it must be added in the liquid state. Because DCA dehumidifiers are critical charge systems, the refrigerant must be weighed in. Therefore, charging this dehumidifier and its remote condenser must always be accomplished by weighing in the charge as a liquid. **Vapor charging cannot be utilized.** With the dehumidifier off, add the refrigerant into the liquid receiver inside of the dehumidifier or at the remote condenser. The receiver is equipped with rotolock valves. Do not add refrigerant into the suction port on the unit. This could cause the compressor to slug and **void the warranty.**

The remote condenser coil must be kept clean from any grass clippings, leaves, dirt, etc. Failure to keep the coil clean will result in poor unit performance and high operating costs. Do not cover the remote condenser during cold months. Proper dehumidification requires year-round operation of the remote condenser.

**Charge with dehumidifier
OFF**

Add to liquid receiver

OWNER'S MANUAL

ELECTRICAL CONNECTIONS

The DCA unit is factory pre-wired. Field wiring is limited to the power wire and the installation of wiring for 24V controls.

Provide and install a main disconnect switch within close vicinity of the dehumidifier. Refer to the unit nameplate for electrical information specific to your unit. All wiring and main disconnect switch should be provided in accordance with all local, state and national electric codes (N.E.C.).

IMPORTANT

Make sure the DCA unit is properly grounded with the correct gauge of wire via the ground lug terminal located in the control panel. Failure to properly ground the unit will void all warranties. Supply voltage must not vary more than 10% from the nameplate voltage while the unit is operating.

MODEL	VOLTS	PHASE	MAXIMUM FUSE SIZE	MINIMUM AMPACITY
DCA 650A/650AWH	208/230	1	25 amp	17.1
DCA 900A/900AWH	208/230	1	30 amp	21.8
	208/230	3	17.5 amp	13.8
	460	3	12 amp	8.1
DCA 1500A/1500AWH	208/230	1	40 amp	30.2
	208/230	3	25 amp	20.7
	460	3	15 amp	10.1
	575	3	12 amp	8.2
DCA 2000A/2000AWH	208/230	1	60 amp	40.5
	208/230	3	35 amp	26.4
	460	3	17.5 amp	12.2
	575	3	12 amp	9.0
DCA 2500A/2500AWH	208/230	1	70 amp	47.7
	208/230	3	40 amp	31.0
	460	3	17.5 amp	13.6
	575	3	15 amp	10.9
DCA 3000A/3000AWH	208/230	1	75 amp	55.4
	208/230	3	50 amp	35.5
	460	3	25 amp	17.3
	575	3	17.5 amp	12.5
DCA 3300A/3300AWH	208/230	1	70 amp	51.7
	208/230	3	60 amp	39.2
	460	3	25 amp	19.2
	575	3	20 amp	16.1
DCA 3600A/3600AWH	208/230	3	60 amp	42.4
	460	3	30 amp	19.9
	575	3	20 amp	15.0
DCA 4100A/4100AWH	208/230	3	60 amp	43.2
	460	3	30 amp	22.3
	575	3	25 amp	17.1
DCA 4400A/4400AWH	208/230	1	90 amp	71.0
DCA 4800A/4800AWH	208/230	3	70 amp	52.6
	460	3	35 amp	24.7
	575	3	30 amp	20.0
DCA 5500A/5500AWH	208/230	3	100 amp	75.5
	460	3	40 amp	30.4
	575	3	35 amp	24.1
DCA 6500A/6500AWH	208/230	3	110 amp	79.5
	460	3	50 amp	36.0
	575	3	40 amp	30.6
DCA 7000A/7000AWH	208/230	3	125 amp	85.2

DCA 8000A	460	3	60 amp	40.7
	575	3	50 amp	35.3
	208/230	3	100 amp	79.4
DCA 9000A	460	3	50 amp	40.4
	575	3	40 amp	31.3
	208/230	3	125 amp	101.1
DCA 11000A	460	3	60 amp	47.8
	575	3	50 amp	38.4
	208/230	3	175 amp	132.8
DCA 14000A	460	3	70 amp	53.7
	575	3	50 amp	42.5
	208/230	3	200 amp	156.8
	460	3	90 amp	75.0
	575	3	80 amp	64.3

Chart A
Fuse & Ampacity Rating

The control wiring should be done according to the wiring diagram provided with the unit. The DCA control circuit operates at 24V.

CONTROLS, LOCATION & MOUNTING

Locate the controls in an area of natural room air circulation, usually near the return air inlet. Avoid areas of hot spots from warm air ducts, radiators or exposure to sunlight or direct room lighting. Avoid mounting the controls on cold outside masonry walls, near doors, windows or air conditioning and heating outlets.

Do not locate the controls in a room that is not being conditioned by the dehumidification system, unless the system has remote sensors (optional).

Controls should be mounted 5 feet from floor level on an interior wall. All controls must be level.

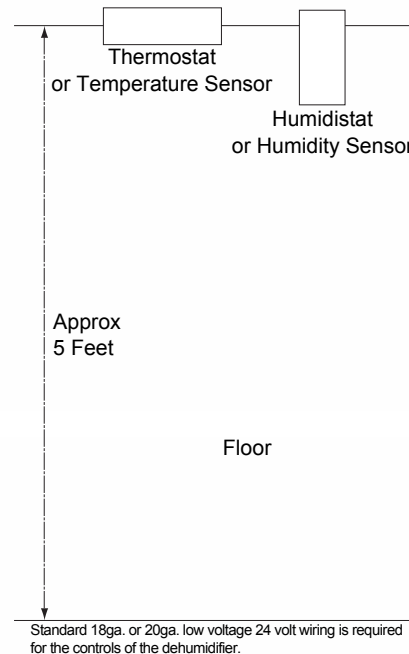

Call DCA with any questions; we will need the unit model and serial numbers.

OWNER'S MANUAL

DCA650AWH - DCA14000AWH INSTALLATION POOL WATER HEATING DEHUMIDIFIERS

POOL WATER PIPING:

Schedule 40 CPVC thermoplastic or copper piping is recommended. Standard PVC, aluminum, galvanized, black iron and cast iron piping must not be used.

The O.D. size of the supply and return water piping must not be downsized from the connection on the DCA Dehumidifier. If the main by-pass valve is more than 10 feet from the dehumidifier, increase the pipe size one size up. Both the supply and return pipe should be insulated for best results.

It is very important that the water flow be verified and matches the chart below.

IMPORTANCE OF POOL WATER CHEMISTRY

It is the responsibility of the indoor pool, spa, whirlpool or water park owner to maintain correct pool water chemistry. Poor pool water quality caused by out of balance pool or spa water chemistry is a serious health and comfort problem. Many times the so called offensive "pool water smell" is a tip off that this water chemistry needs attention. It is the responsibility of the pool or spa manager to test the water chemistry daily with a pool water test kit. This kit will analyze PH - total alkalinity - free available and combined chlorine in the water. Proper pool water treatment procedures can only be obtained from the pool, spa or whirlpool equipment or pool water chemical suppliers. With this also is the verification of proper pool or spa water temperature.

Poor pool or spa water chemistry will result in the formation of scale and corrosion within the dehumidification system which will drastically shorten the effective service life of the dehumidifier.

FAILURE TO FOLLOW THE ABOVE RECOMMENDATIONS WILL RESULT IN THE VOIDING OF ALL WARRANTIES FROM DCA THAT WERE EITHER EXPRESSED, IMPLIED OR WRITTEN.

STORAGE OF POOL OR SPA WATER CHEMICALS:

This is an area of swimming pool or spa management that most times is either neglected or forgotten about altogether with often dire consequences. Pool water chemicals, by their very nature, are some of the most corrosive chemicals that are available for non-professional use.

Under no circumstances should the storage of spa or pool water chemicals be in the same room with the dehumidifier. The very corrosive effects of these disinfectants will quickly attack any and all metal surfaces that they come in contact with. Not only will the dehumidification system be affected, but also any pool or spa water heating systems, pumps or other mechanical devices such as controls will be adversely affected.

Proper storage must be in another area of the building or in a sealed non-metallic cabinet that will ensure that no vapor release of the chemicals will occur. It will be easy to detect, if the early failure of equipment occurs, that improper chemical storage was the cause.

FAILURE TO FOLLOW THE ABOVE RECOMMENDATIONS WILL RESULT IN THE VOIDING OF ALL WARRANTIES FROM DCA THAT ARE EITHER EXPRESSED, IMPLIED OR WRITTEN.

DCA MODEL #	GPM @ 25°F Diff.	Pipe Pressure Drop ft. H ₂ O
DCA 650AWH	2.5	2.8
DCA 900AWH	4.5	8.4
DCA 1500AWH	5.0	3.9
DCA 2000AWH	8.5	9.9
DCA 2500AWH	10.0	7.0
DCA 3000AWH	13.0	10.5
DCA 3300AWH	15.0	8.2
DCA 3600AWH	16.0	9.0
DCA 4100AWH	17.0	5.7
DCA 4400AWH	18.0	6.2
DCA 4800AWH	23.0	8.6
DCA 5500AWH	21.0	8.5
DCA 6500AWH	25.0	7.1
DCA 7000AWH	33.0	10.8
DCA 8000AWH	17.0 each	5.7 each
DCA 9000AWH	23.0 each	8.6 each
DCA 11000AWH	21.0 each	8.5 each
DCA 14000AWH	33.0 each	10.8 each

MINIMUM REQUIREMENTS FOR STARTUP

The following items are required and must be completed before startup can be performed.

1. All installations and wiring diagrams must be studied and understood before proceeding with the installation. If there are any questions, contact the factory.
2. All wiring must be completed. This includes the main power, controls and sensors.
Check and confirm that all wiring connections in the dehumidifier and remote condenser are tight.
3. All refrigeration and/or water piping must be completed.
4. All additional refrigerant R-410A required per instructions must be added.
5. Proper water flow, if required must be established.
6. Duct work, including duct, grills and diffusers must be completed.
7. A thorough leak check should be performed. Due to the fact that the unit may be damaged while in transit, we recommend that all field and factory connections be leak checked.

Tools Needed:

1. Manifold set/or sets for pressure readings.
2. Air flow meter/s. Magnehelics in the ranges of 0 to 1.0 in. w. c. or 0 to 2.0 in. w. c.
3. Volt-Ohm-Amp meter/s.
4. Temperature meters with probes, strap on bulbs and a sling psychrometer.
5. Assorted refrigeration and standard tools.
6. See page 16 for start-up directions.

OWNER'S MANUAL

AIR FLOW BALANCING

All standard DCA units are shipped from the factory with the airflow set at the standard CFM for your particular model and .5 WC external static pressure E.S.P. Refer to DCA specification sheet for more information.

Use an incline manometer, a digital manometer, or a pressure differential gauge such as Magnahelic, to verify that the unit will deliver adequate CFM and E.S.P. as it is installed. The access doors and clean air filters must be in place at all times the blower is running.

CHART A

Shows the location of the air balancing access ports and where to insert the HI and LO pressure tubes of the manometer or gauge. Measure the pressure differential across the reheat condenser coil to verify air flow.

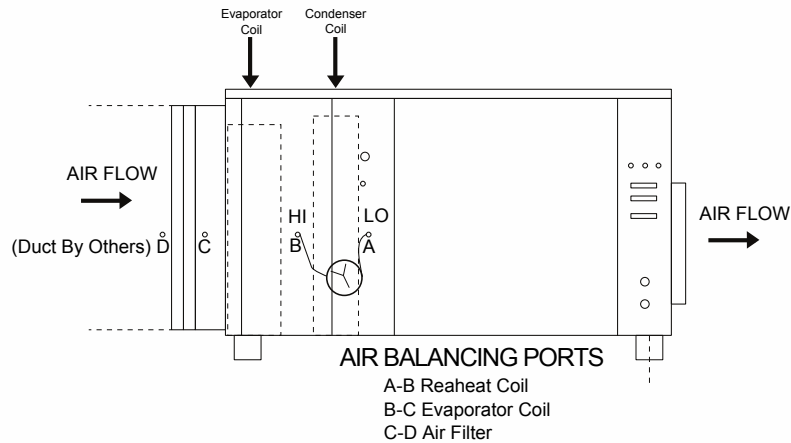

This is best accomplished with a Magnahelic® having a 1 or 2 inch range and inserting measuring tubes 6 to 8 inches into the ports.

CHART B

Shows the static pressure drop across the reheat condenser coil at standard CFM for each DCA model.

Chart B

UNIT	STANDARD CFM	STATIC PRESSURE DROP (INCHES W.C.)
DCA 650A	650	
DCA 900A	950	
DCA 1500A	1500	
DCA 2000A	2000	
DCA 2500A	2500	
DCA 3000A	3000	
DCA 3300A	3300	
DCA 3600A	3600	
DCA 4100A	4100	SEE LABEL ON UNIT
DCA 4400A	4400	
DCA 4800A	4800	
DCA 5500A	5500	
DCA 6500A	6500	
DCA 7000A	7000	
DCA 8000A	8000	
DCA 9000A	9000	
DCA 11000A	11000	
DCA 14000A	14000	

OWNER'S MANUAL

If the pressure differential reading differs from the chart, the following steps should be taken:

1. PRESSURE LOWER THAN CHART

- A. Check for restrictions in duct work such as closed registers, blocked return air grills or dampers in duct work not adjusted properly.
- B. Check the filters to verify that they are clean.
- C. Check belt tension. The belt should have approximately 1" of play up or down. Replace any worn or frayed belt or worn pulleys.
- D. If the duct work is free of obstructions, the adjustable motor pulley should be closed until correct pressure reading is achieved.

2. PRESSURE HIGHER THAN CHART

- A. The unit does not have duct work or dampers in duct work not adjusted properly.
- B. Air filters are not in the unit.
- C. To reduce the air flow pressure, open the adjustable motor pulley and reset the belt tension to 1" play up or down until the correct pressure reading is achieved.
- D. In a no duct work installation (Free blow) a 4 foot duct extension must be installed on supply outlet of unit. Adjust motor pulley following the instructions above.

NON DUCTED INSTALLATION

When the installation of duct work is not possible, the unit must be positioned in such a manner that return air into the unit is not obstructed and sufficient air can enter the unit. Locate the unit as high as possible, while remaining accessible for normal maintenance and service. Direct air from supply of unit toward exterior glass, skylights and walls. Short cycling of air or loop effect will give poor performance. Position for optimum air circulation for best results.

UNIT OPERATION

ATTENTION INSTALLERS / OPERATORS

Main power to the unit crankcase heater must be on for 12 hours before the unit is started. Under no circumstances should the unit be run for temporary heat when building construction is in progress or when there is no water in the pool.

HUMIDISTAT

This control turns the unit on or off when the humidity in the room rises above or falls below the set point of the control.

The control is factory set and covers a humidity range of 20% to 80%. A typical pool room humidity setting would be between 50% to 60%. Remember that the lower the humidity setting, the longer the unit will run, and the higher the operating costs.

AUTOMATIC CHANGEOVER THERMOSTAT

Other control systems may be provided. The following explains a standard snap action humidistat and auto change over thermostat. See additional instructions for other control systems available, not in this manual.

This control maintains the temperature in the room. Set thermostat at desired temperature, usually between 75° F to 85° F. The thermostat is an automatic change over type which will automatically switch to air conditioning (with remote condenser option) or heating. This thermostat provides the following operating options.

SYSTEM SWITCH

HEAT - In this position, warm air will be supplied to the pool room. The unit will start on a call from either the humidistat or the thermometer. If the unit is not connected to a remote condenser, the system switch must be in the heat position.

COOL - This position must not be used. See auto position.

AUTO - This position allows the unit to run and supply either warm air or cool air to the room. The unit will run in the cooling cycle if temperature rises above set point or in the heating cycle if temperature drops below set point.

OFF - This position disengages the unit regardless of temperature or humidity.

IN NO CIRCUMSTANCE SHOULD THE MECHANICAL ROOM OR THE ROOM HOUSING THE DEHUMIDIFIER SERVE AS A RETURN AIR PLENUM TO THE DEHUMIDIFIER. ALL RETURN AIR DUCTWORK MUST BE FIRMLY ATTACHED TO THE DEHUMIDIFIER. THIS IS ESPECIALLY TRUE IF THE MECHANICAL ROOM HOUSES ANY FOSSIL FUEL BURNING APPLIANCE SUCH AS A GAS OR OIL POOL OR SPA WATER HEATER OR POOL ROOM SPACE HEATER.

DEATH CAN RESULT

Pre Start-Up Questions:

- Have the unit and associated equipment been inspected for internal shipping damage?
- Has it been thoroughly leak-checked?
- Have all electrical connections in the dehumidifier and remote condenser electric box been checked for tightness?
- Have you read the owner's manual and other supplied literature?
- Are the start-up/servicing personnel familiar with the unit?
- Has the unit ever been run?
- If not, has the crankcase heater been on for 12 hours?
- If the unit has been run:
 - Check the filters, belts and coils for debris
- Is other equipment connected
- Is other equipment connected to the unit?
 - Remote condenser
 - Duct heater or other heating equipment
 - Fresh air unit
- If so:
 - By whom was it manufactured?
 - Was the remote condenser leak checked and charged properly?
 - Is the heater wired to a pilot relay or motorized valve?
 - Whose thermostat and humidistat are controlling the equipment?
 - Will air be blowing on or near the controls and sensors?
- Have the jumper wires on the schematic been checked?
- Do you have...
 - Jumper wires?
 - Manifold gauge?
 - Magnahelic or other pressure differential gauge for less than 1" differential measurements?
 - Ammeter?
 - Volt/Ohm meter?
 - Thermometers?

Start Up Procedure:

Leave the valves to the remote condenser (if any) closed until later.

Check the pressure in the system. (Ports are on the outside of the unit near the control panel; compare this reading to a temperature/pressure chart.)

Ensure that all panels are on the unit.

Record the relative humidity in the controlled space.

Disable the controls.

Set back the compressor time delay/s.

Apply a jumper (if necessary) for blower operation and start the blower.

Check:

- The blower rotation. (3 phase only)
- The air flow across the reheat condenser: Air balancing ports A (Lo) and B (Hi).
- The transformer primary voltage.
- The transformer secondary voltage.
- The blower contactor input voltage.
- The blower contactor output voltage.
- The blower motor running amperage.
- The blower motor amperage on the nameplate.

Turn the unit off and use a jumper to start in the dehumidification (reheat) mode.

Start the unit and let it run a minimum of 10 minutes.

Check:

- Supply air temperature
- Return air temperature
- Discharge pressure
- Suction pressure
- Compressor contactor input voltage
- Compressor contactor output voltage
- Compressor running amperage
- Compressor nameplate amperage

Be sure to record your measurements on the Start-Up form.

Is the sight glass clear? (It is located inside the dehumidifier, near the TXV.)

Turn off the unit.

Open the valves to the remote condenser. (If any)

Move the jumper to the air-conditioning mode.

Turn the unit on.

Check that the remote condenser fan is operating in the correct rotation.

Record the outdoor air temperature and humidity.

Wait at least 10 minutes; then check the refrigerant pressures and amperage draws in this mode, as well as the entering and leaving air temperatures.

Repeat the process for the water heating mode if so equipped.

Check that the auxiliary heaters operate (If any).

Turn off the power.

Remove the jumper and re-attach the controls.

Check that all modes operate properly using the controls.

Return the time delay/s to their normal settings.

Maintenance and Service Procedure

Your DCA dehumidifier requires minimal maintenance. The following areas should be checked as required:

1. Air filters should be checked once per month. Dirty filters should be replaced immediately, and should be available locally. Dirty or clogged filters will seriously affect the performance of the unit.
2. Check the blower belt once every six months. Turn off the power supply before inspecting the belt. If the belt is worn or frayed, replace it with a new one of the same size and rating. Be certain to restore the power upon completion.
3. The blower motor and blower have permanently lubricated bearings that do not require any additional lubrication.
4. Check the drain pan every six months and clean out any residue that may have accumulated.
5. The coils should be inspected annually for dirt build-up and cleaned if necessary.
6. All electrical connections should be re-tightened every six months. The power to the dehumidifier and all associated equipment must be off during this procedure.

In the event of power or equipment failure, the pool surface should be covered with a suitable cover to prevent excessive evaporation and all pool heating equipment turned off.

Caution

In the event of a unit malfunction, only qualified service technicians should perform repairs to the unit. The unit contains high current electrical circuits and high pressure refrigerants which could result in death.

Operation with Remote Condenser

GENERAL

There are two basic modes of Operation: Dehumidification (known as reheat) and Cooling. In the reheat mode all of the latent heat converted into sensible heat is returned to the air stream, just as it is in a residential basement dehumidifier. In this mode the refrigerant is condensed in the coil located behind the evaporator coil. In the cooling mode, the refrigerant is routed to the remote condenser located outside and condensed there. The difference between the two modes of operation is where the heat is being discharged: inside or outside.

REHEAT

Reheat (dehumidification) is the normal mode of operation. The heat generated by the dehumidification process is put into the air in the controlled space until the temperature is satisfied.

COOLING

If dehumidification is required and the room is at the set temperature, the unit is automatically switched to the cooling mode (remote condenser). The cooling mode can override the humidistat and drop the humidity below the set point until the cooling set point is reached.

All DCA dehumidifiers can be set for automatic or continuous blower operation. This can be accomplished at the thermostat, or by an appropriate low-voltage jumper wire on the DCA unit (see system schematic).

If additional room heat is required, all DCA dehumidifiers are provided with two stages of heat control. Field-supplied pilot relays may need to be installed in the additional heating equipment. Many units can be configured to thermostatically start the compressor on a call for heat. This will override the humidistat and lower the humidity until the heating set point is reached.

Some units are equipped with a simple air defrost timer which shuts off the compressor for 10 minutes each hour (adjustable). The evaporator leaving air temperature control locks out the defrost timer when the coil is above 32°F. The blower runs during the defrost cycle.

Operation with Water Heating Condenser

GENERAL

There are three basic modes of operation: Dehumidification (known as Reheat), Water Heating Air-Conditioning, and Remote Condenser Air-Conditioning. In the reheat mode, all of the latent and sensible heat is returned to the room air stream, just as it is in a residential basement dehumidifier. In this mode the refrigerant vapor is condensed in the reheat condenser coil located behind the evaporator coil. In the water heating a/c mode, the refrigerant vapor is condensed in the water coil also located in the dehumidifier; in the remote condenser a/c mode, the refrigerant vapor is condensed in the outdoor remote condenser where the heat is then dissipated into the outdoor air. The difference between these modes of operation is where the heat is being directed: into the air inside, into the water, or into the air outside.

REHEAT

Reheat (dehumidification) is the normal mode of operation. The heat generated by the dehumidification process is put into the air in the controlled space until the room thermostat is satisfied.

WATER HEATING A/C

Whenever the air temperature exceeds the thermostat set point the unit will automatically switch to the air-conditioning mode. When the dehumidifier is operating in the air-conditioning mode and the pool water temperature is not satisfied, the heat will then be used to heat the pool water. A water flow switch is built into the unit to prevent water heating a/c when there is insufficient water flow.

REMOTE CONDENSER A/C

The air-conditioning mode uses one of two condensers: the water condenser mentioned above, and the remote condenser. Only after the water temperature reaches its set point, or there is insufficient water flow, will the unit automatically switch to the remote condenser. Under high heat conditions, it is possible that the air-conditioning mode will drop the humidity below the humidistat set point. If both the air and water temperatures are at their respective set points, and no remote condenser has been installed, the compressor will not start.

Most water heating a/c dehumidifiers are built for continuous blower operation. If not, this can be accomplished at the thermostat, or by an appropriate low-voltage jumper wire installed on the DCA unit (see the schematic on the dehumidifier).

If additional room heat is required, all DCA dehumidifiers are provided with control for two stages of heat. Field supplied pilot relays may need to be installed in the additional heating equipment. Control is also provided for a dedicated pool heating unit to supplement the water heating a/c mode.

Some units are equipped with motorized bypass dampers to maintain a static pressure drop across the evaporator coil of between 0.30 and 0.35 in. w.c.

OWNER'S MANUAL

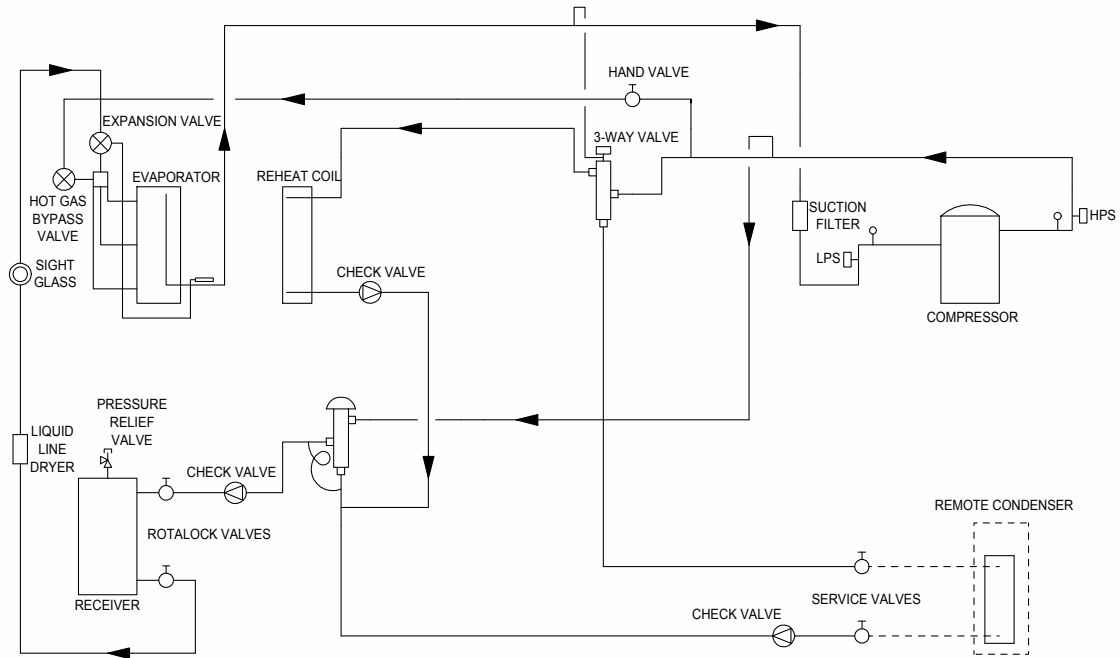

A typical unit.
In Reheat (Dehumidification) Mode the 3-way valve (solenoid) is energized.

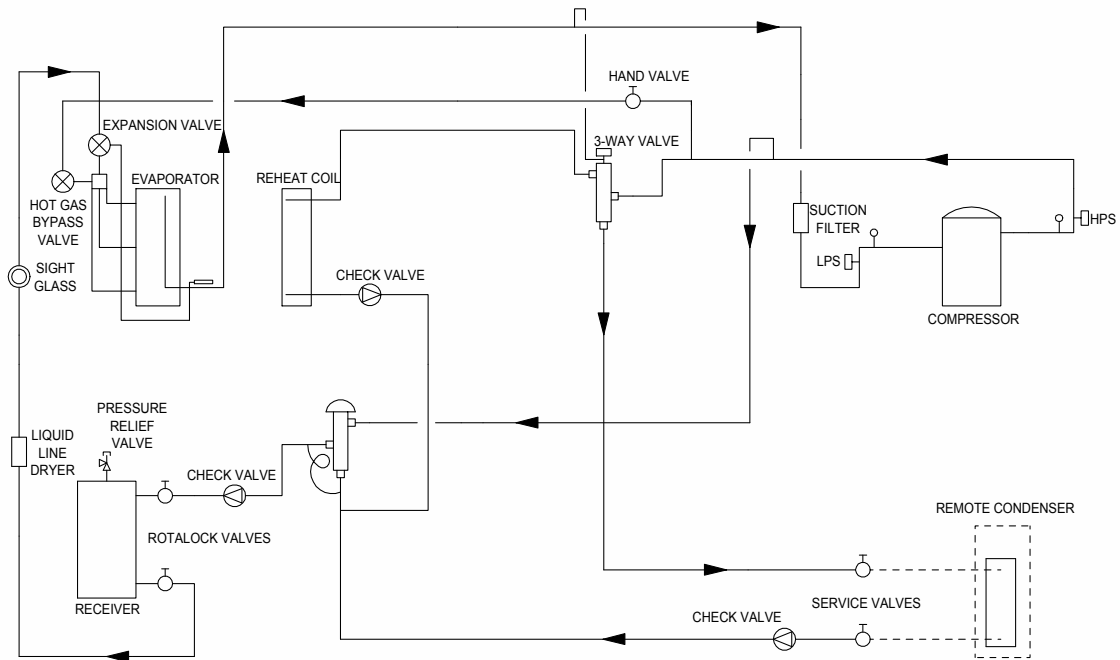

A typical unit.
In Cooling Mode the 3-way valve (solenoid) is de-energized.

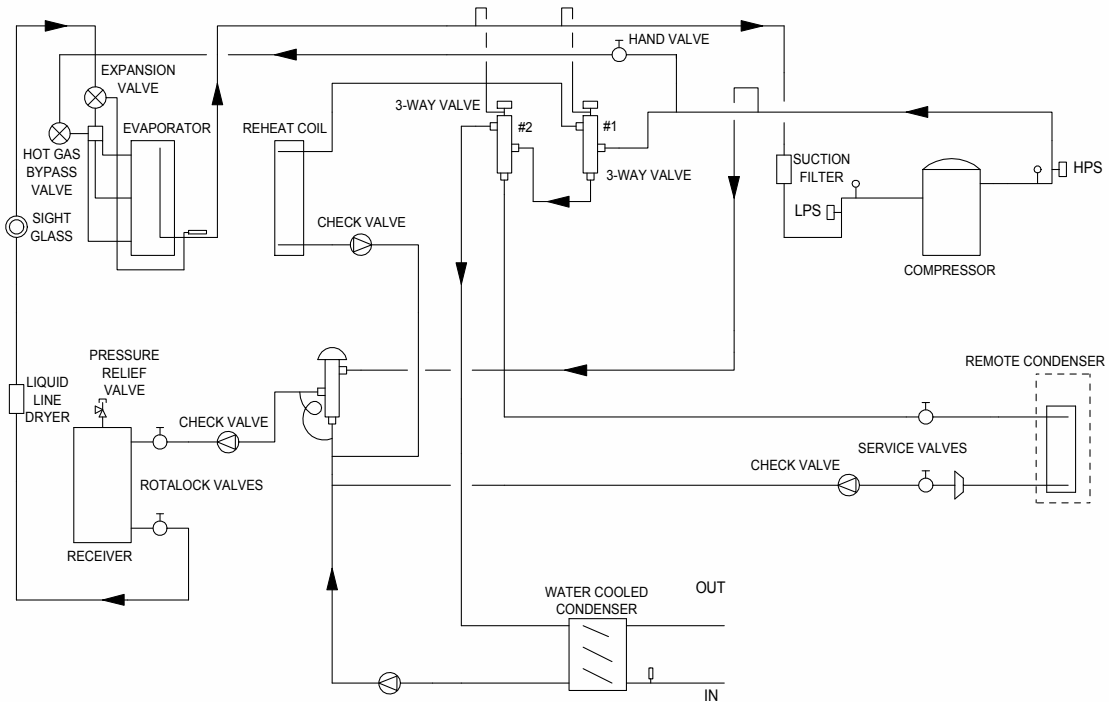

A typical unit with water heating option.
When the unit is in the Water Heating Mode, #1 3-way valve must be de-energized, and #2 3-way valve must be energized.

Johnson Controls 600 Set Point Readjustment

MAIN PROGRAM FACTORY PRE-SET

To Change Temp Set Points:

Press....**Menu**

Temp Set?....**Yes**

Cooling Set?....**Yes**

Cooling....Use ▼ or ▲ to set temp, then **Yes**

Heating Temp?....**Yes**

Heating....Use ▼ or ▲ to set temp, then **Yes**

F/°C set?....No Exit Menu....**Yes**

Fan On or Auto Mode:

Press....**Menu**

Temp Set?....**No**

System Mode Set?....**No**

Fan Mode Set?....**Yes**

Use ▼ or ▲ to select On or Auto, then **Yes**

Exit?....**Yes**

T775U 2006 - Humidity Set Point Readjustment

Press and release....**Menu**

Program: Press ►

Mode 1: Press ▼ to Relay 1

Relay 1: Press ►

Set Point: Press ►

Relative Humidity: Press ▲ or ▼ to set point then press ►

Differential: Press ► then press ▲ or ▼ to set point then press ►

Action: Press ▲ or ▼ to dehumidify, then press ►

Exit: press ►

Relay 2 (if used*): Press ► (*if not, scroll down to Exit)

Set Point: Press ►

Relative Humidity: Press ▲ or ▼ to set point then press ►

Differential: Press ► then press ▲ or ▼ to set point then press ►

Action: Press ▲ or ▼ to dehumidify, then press ►

Exit: Press ►

Exit: Press ►

Exit: Press ►

Reprogramming Complete!

T775L 2007 - Temperature Set Point Readjustment

Press and release...Menu

Program: Press ▶

Loop 1: Press ▶

Set Point: Press ▶

Adjust the set point with ▲ or ▼ to to desired temperature, then press ▶

Throt Rng: press ▶

Scroll up or down to the desired range, then press ▶

Sensor A: Press ▶

Heat/Cool: Press ▶

Heat: Press ▶

Exit: Press ▶

Loop 2: Press ▶

Set Point: Press ▶

Adjust the set point with ▲ or ▼ to to desired temperature, then press ▶

Throt Rng: press ▶

Scroll up or down to the desired range, then press ▶

Sensor A: Press ▶

Heat/Cool: Press ▶

Cool: Press ▶

Exit: Press ▶

Exit: Press ▶

Exit: Press ▶

Set Point Readjustment Complete!

T775B 2040 - Temperature Set Point Readjustment

Press and release...Menu

Program: Press ▶

Relay 1: Press ▶

Set Point: Press ▶

Adjust the set point with ▲ or ▼ to to desired temperature, then press ▶

Scroll down with ▼ to exit, then press ▶

Relay 2: Press ▶

Set Point: Press ▶

Adjust the set point with ▲ or ▼ to to desired temperature, then press ▶

Scroll down with ▼ to exit, then press ▶

Relay 3: Press ▶

Set Point: Press ▶

Adjust the set point with ▲ or ▼ to to desired temperature, then press ▶

Scroll down with ▼ to exit, then press ▶

Exit: Press ▶

Exit: Press ▶

Reprogramming Completed!

TROUBLESHOOTING - OWNER/USER

(The following is a guide for the owner/user to follow in the event the unit malfunctions. If further service is required, a qualified service technician must be called.)

PROBLEM	POSSIBLE CAUSE	SOLUTION
Unit does not start	Main power off.	Turn main Power On. Reset circuit breaker or replace blown fuses.
	Thermostat system switch in off position.	Set system switch in automatic position.
	Humidistat turned off.	Turn humidistat on and set to desired RH level, usually between 50% to 60% R.H.
	Humidistat set too high.	Lower humidistat setting.
Unit does not shut off	Malfunctioning controls.	Call service technician to repair or replace control.
Unit not operating properly, high humidity in room	Humidistat turned off.	Turn humidistat on and set to desired RH level, usually between 50% to 60%.
	Air filters dirty.	Replace filter(s).
	Controls located in room that is not being treated by dehumidifier.	Change location of controls into room being treated by dehumidifier.
	Pool water temperature too high.	Lower pool water temperature usually between 78°F to 82°F. Usually 2°F to 4°F below room temperature.
	Supply or return air registers blocked or closed.	Remove blockage and open registers. Check diffusers, make sure they are pointed in proper direction.
	Blower belt loose & slipping.	Check for worn belt and tighten or replace as necessary.

TROUBLESHOOTING - SERVICE TECHNICIAN

(The following is a guide intended for use by qualified service personnel only. CAUTION High Voltage and refrigerant under high pressure are present.) Contact DCA service for assistance and information not in this manual. Be certain to have the model and serial number before you call.

PROBLEM	POSSIBLE CAUSE	SOLUTION
Compressor will not start	Broken or loose wire	Check all wire & connections.
	Compressor off on internal overload.	Allow to cool, will start automatically.
	Low voltage to unit.	Check voltage and correct.
	High pressure switch tripped.	Press reset switch.
	Low pressure switch tripped.	Check refrigerant charge.
	Compressor discharge temperature switch tripped.	Check refrigerant charge.
	Defective start relay, start capacitor, run capacitor, transformer or compressor.	Replace defective component.
Dehumidifying coil iced up.	Return air below 45°F.	Raise return air temperature.
	Filters dirty or clogged.	Replace filters.
	Low air flow.	Check blower motor and belt.
		Adjust blower speed
		Check blower rotation.
		Check dust design. Refer to manual for proper sizing and design.
	Low refrigerant Charge.	Add Refrigerant. (See charging procedure)
	Bad expansion valve.	Replace expansion valve.
	Restricted drier.	Replace drier.
Restricted distributor tubing.	Replace distributor tubing.	
Restricted distributor.	Replace distributor.	

TROUBLESHOOTING - SERVICE TECHNICIAN

(The following is a guide intended for use by qualified service personnel only. CAUTION High Voltage and refrigerant under high pressure are present.)

PROBLEM	POSSIBLE CAUSE	SOLUTION
High head pressure	<p>Low air flow. Return air short cycling.</p> <p>Refrigerant overcharge.</p> <p>Non-condensable in system.</p> <p>Dirty coils.</p> <p>Dirty filters.</p>	<p>Adjust blower speed. Check duct design and readjust supply and return all registers.</p> <p>Adjust refrigerant. (See charging procedure).</p> <p>Evacuate and recharge system.</p> <p>Clean all coils in unit and remote if equipped.</p> <p>Replace filters.</p>
Head pressure switch tripping (See as above)	<p>Blower running too slow</p> <p>Blower turning backwards.</p> <p>Motor going off on internal overload.</p> <p>Dirty filters.</p> <p>Supply and return air registers restricted or blocked.</p> <p>Refrigerant overcharge.</p> <p>Dirty coils</p> <p>Defective head pressure switch.</p>	<p>Adjust blower speed up.</p> <p>Change blower rotation. (3 phase only)</p> <p>Check for rated AMP draw. Replace motor if defective.</p> <p>Replace filters.</p> <p>Remove restrictions or blockages.</p> <p>Adjust refrigerant. (See charging procedure).</p> <p>Clean all coils in unit and remote if equipped.</p> <p>Replace head pressure switch.</p>
Low head pressure	<p>Low refrigerant charge.</p> <p>Return air temperature too low.</p>	<p>Add refrigerant. (See charging procedure).</p> <p>Return air temperature must be minimum 45°F.</p>

TROUBLESHOOTING - SERVICE TECHNICIAN

(The following is a guide intended for use by qualified service personnel only. CAUTION High Voltage and refrigerant under high pressure are present.)

PROBLEM	POSSIBLE CAUSE	SOLUTION
High suction pressure	High air flow.	Incorrect duct work causes stratification of air on inlet.
	Return air temperature too high.	Lower temperature in room.
Low suction pressure	Defective compressor.	Replace compressor.
	Refrigerant charge low.	Adjust refrigerant. (See charging procedure).
	Low air flow..	Adjust blower speed. Check blower, motor and pulley.
	Return air temperature too low.	Raise return air temperature.
	Dirty filters.	Replace filters..
High humidity in space	Incorrect duct work.	Check duct work design. (See manual)
	Low air flow.	Adjust blower. Check blower, motor and pulley.
	Dirty filters.	Replace filters.
	Outdoor condenser not operating properly.	Clean outdoor coil and check blower, motor and belt.
	Refrigerant system overcharge.	Check pressures. Adjust per manual.
	Unit too small or not enough capacity to handle humidity and problem.	Refer to guide lines regarding sizing dehumidifiers for load and applications.

OWNER'S MANUAL

CONTACT INFORMATION

Terri Parsons, Receptionist, Purchasing, Accounts Payable	262-377-7501 tparsons@dehumidifiercorp.com
Mitch Fisher, Senior Sales Engineer	262-377-7501 mfisher@dehumidifiercorp.com
Zach Onan, Inside Sales	262-377-7501 zonan@dehumidifiercorp.com
Arek Gdowski, Engineering	262-377-7501 agdowski@dehumidifiercorp.com
Errol Gelhaar, Engineering	262-377-7501 egelhaar@dehumidifiercorp.com
Danielle Schroeder, Assistant Comptroller, Order Entry, Logistics	262-377-7501 dschroeder@dehumidifiercorp.com
Graham Gelhaar, Tech Support, Parts, Warranty, Service and Installation	262-377-7501 ggelhaar@dehumidifiercorp.com
Tony Giuffre - BSME, Director of Engineering	262-377-7501 tgiuffre@dehumidifiercorp.com
Rick Heil, Tech Support, Parts, Warranty, Service and Installation	262-377-7501 rheil@dehumidifiercorp.com
Gary Metzger, Comptroller	262-377-7501 gmetzger@dehumidifiercorp.com
Jim Metzger, VP Sales	262-377-7501 jmetzger@dehumidifiercorp.com

W53 N550 HIGHLAND DRIVE
P.O. BOX 0917
CEDARBURG, WI 53012
PHONE: 262-377-7501
E-MAIL: info@dehumidifiercorp.com

www.dehumidifiercorp.com

**W53 N550 HIGHLAND DRIVE
P.O. BOX 0917
CEDARBURG, WI 53012
PHONE: 262-377-7501**

E-MAIL: info@dehumidifiercorp.com