

SY SERIES

SCOTCH YOKE ACTUATOR

INSTALLATION AND OPERATING INSTRUCTION MANUAL



Manufacturing program:



Quality & Environmental Management:





SCOTCH YOKE PNEUMATIC ACTUATORS

MMM-ACTREG-S&Y Rev.0

REVIEW CONTROL

PROCEDURE REF. DOC. MMM-ACTREG-S&Y

<i>Rev.</i>	<i>Date</i>	<i>Carried out</i>	<i>Approved</i>	<i>Description</i>
0	03-12-2012	F. Zanuy	J.Tejedor	First Edition



SCOTCH YOKE PNEUMATIC ACTUATORS

MMM-ACTREG-S&Y Rev.0

Index

- 1.-Sumarize
- 2.-Working Conditions & Application
- 3.-Technical Data
- 4.-Installation Tube & Fitting
- 5.-Operation
- 6.-Adjustment of Valve On/Off Position
- 7.-Module Design Instruction
- 8.-Assembly Drawing & Parts List
- 9.-Module Replacement
- 10.-Cautions
- 11.-Maintenance

Appendix

Appendix 1: JC-MI-S&Y-01E: Pneumatic Cylinder of Scotch Yoke Actuators



SCOTCH YOKE PNEUMATIC ACTUATORS

MMM-ACTREG-S&Y Rev.0

1.- Summarize

The instruction manual for SF series scotch yoke pneumatic actuators for all models of SY01F14, SY01F16, SY01F25, SY01F30, SY01F35, SY01F40, SY01F48, and SY01F60.

2.- Working Conditions & Application

The Ambient Temperature:

Standard actuator: -20°C to +80°C

High temperature actuator: -20°C to +120°C

Operating Pressure:

Pneumatic actuator: 3~7 Bar

Operating Media:

Pneumatic actuator: dry and clean compressed air

SY series actuators are available for Ball Valves, Butterfly Valves, Plug Valves, Air Valves and all the 90° rotation valves, widely applicable to the chemical industry, food & beverage, metallurgy, offshore platform, pharmaceuticals, energy, paper, textile and other industries.

3.- Technical Data

Output Torque:

Double Acting: 830~226,400Nm

Spring Return end torques: 307~71753Nm



SCOTCH YOKE PNEUMATIC ACTUATORS

MMM-ACTREG-S&Y Rev.0

4.- Installation, Tube & Fitting

4.1.- The installation environment should be avoided in high temperature, low temperature, high moisture and corrosive place.

4.2.- The conduit is usually use brass and stainless steel pipe , try to avoid vibration, it's easy to make the tubes slapped, damaged, otherwise it will cause to leakage. It's necessary to take action when violent vibration. For it may vibration or impact during transportation, check the interface of all tubes before using the products, if there are any slaps or leakage, please screw the interface till no leakage.

4.3.- The conduit size of electrical accessories:

The different pneumatic actuators have different air inlet sizes, from 3/8" to 2", users should choose the tube size according to specific requirement. The air inlet is sized by different pneumatic actuator size. Detailed sizes please refer to the following table:

4.4.- Air inlet size table:

Actuator	200	250	300	350	400	450	500
Air Inlet	3/8"	1/2"	1/2"	1/2"	3/4"	3/4"	3/4"
Actuator	550	600	700	800	900	1000	1100
Air Inlet	3/4"	1"	1"	1 1/2"	2"	2"	2"

4.5.- The quick operation actuator must use bigger size air tube. Choose the same size brass, stainless steel or flexible metallic tube from compressor or air reservoir to actuator tubes.

4.6.- Operating media is filtered dry air, dew point over -15°C must use dryer.

4.7.- Pneumatic Actuator Air Inlet Position Indication.

Single acting pneumatic actuator

Double acting pneumatic actuator

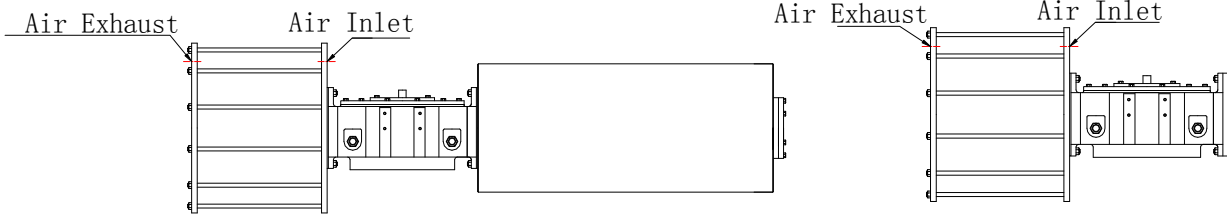

4.8.- Dimensions and Positions of Accessories Installation

Bracket dimension for solenoid valve, air valve, air set

SF14~SF25

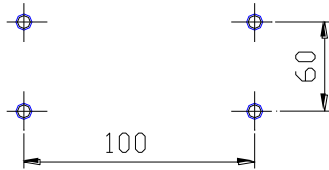

SF30~SF60



Top mounting pad of switchbox & E/P positioner

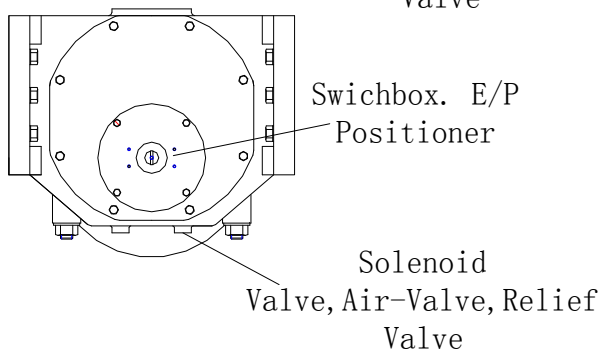
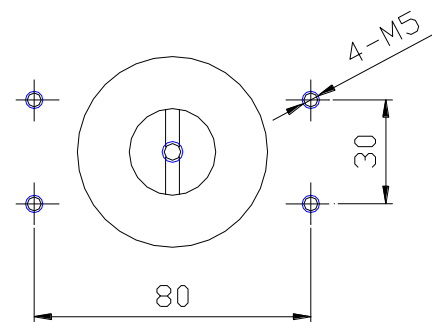
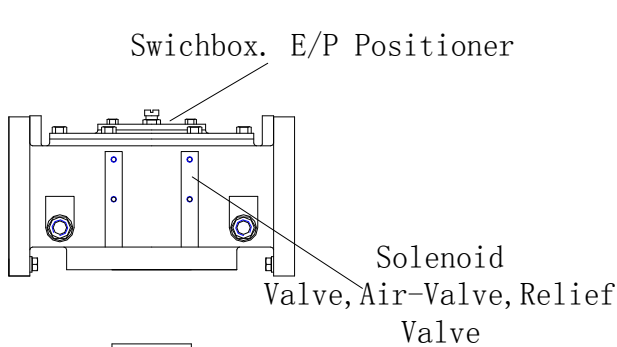

5.- Operation

5.1.- Auto-Operation

On/Off Control Pneumatic Actuated Valve:

- A) The valve open when solenoid valve energized (Failure Close Type)
- B) The valve close when solenoid valve de-energized (Failure Close Type)
- C) The valve close when solenoid valve energized (Failure Open Type)
- D) The valve opens when solenoid valve de-energized (Failure Open Type)

Modulating Control Pneumatic Actuated Valve:

To give 4-20mADC signal to Electro-Pneumatic positioner(or 0.02~0.1Mpa to Pneumatic-Pneumatic positioner) the valve position can be proportional controlled by the input signal.

5.2.- Manual Operation Way

5.2.1.- Double Acting Pneumatic Actuator declutchable worm gear manual override the declutch able worm gear manual override are sued for SY01F14 & SY01F16 double acting pneumatic actuators.

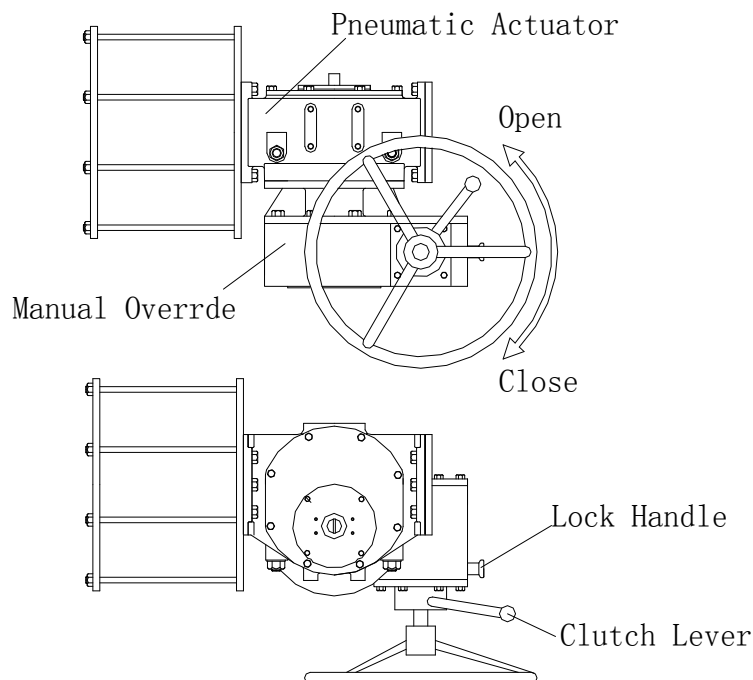

To release the air firstly, How to operate the declutchable manual override, to engage manual operation. First pull out the lock handle, and then rotate the clutch lever in anti-clockwise direction until engagement takes place. To return the automatic mode, first pull out the lock handle, then rotate the clutch lever in clockwise direction until engagement takes place.

5.2.2.- Single Acting Pneumatic or hydraulic Actuator

5.2.2.1.- Jackscrew Operator

The jackscrew operator only available in SY01F14 & SY01F16 single acting actuator which is side mounted operator. Turning the hand wheel, control the valve position by screwing in & out the trapezoid screw in spring case. For the valve, turn hand wheel clockwise to open, counter-clockwise to close.

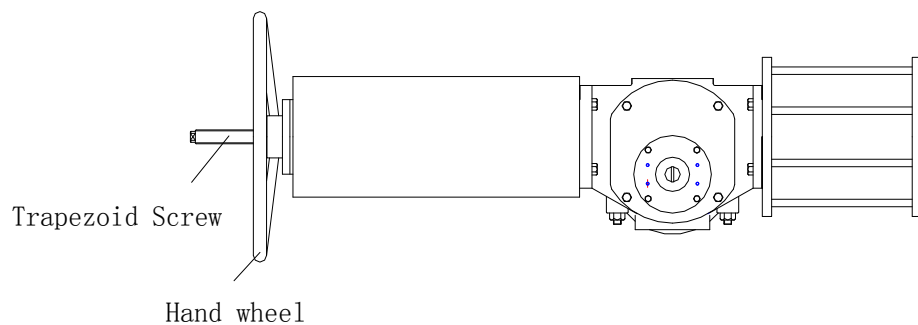

SY01F14 & SY01F16 after manual operation, screw out the trapezoid screw when it change to auto-operation way, to ensure the auto-operation smoothly realized. Avoid to screw out integral trapezoid screw, the valve open & close position will be influenced if the screwing is not in place.

5.2.2.2.-Hydraulic Manual Override

The hydraulic manual override is used for SY01F25 ~ SY01F60. The hydraulic manual override is an integral device which consists of manual pump, tank, globe valve, check valve and other parts, easy to operate and maintain. The major parts as follows:

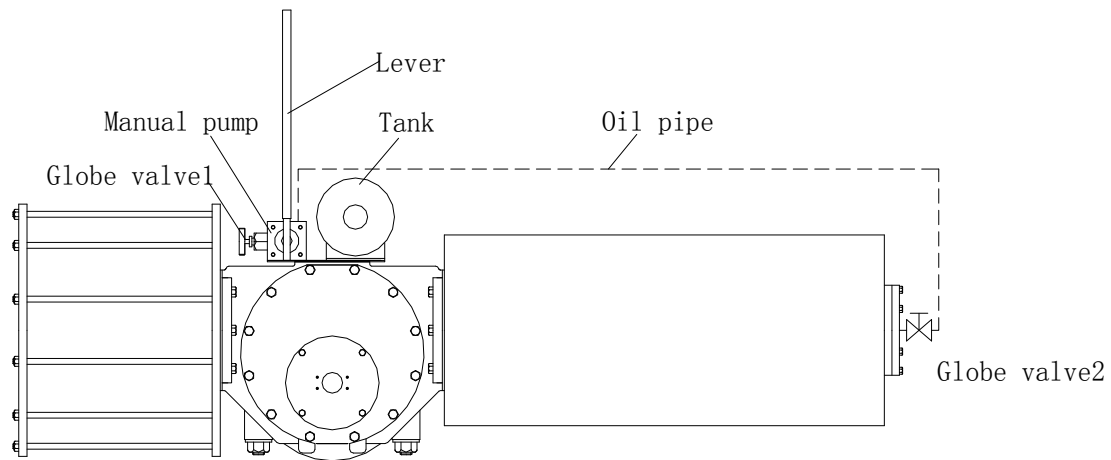

The Operation of Hydraulic Manual Override:

- a). Close globe valve(1), open globe valve (2);
- b). Inject oil to the oil cylinder by operating manual pump through lever handle, piston of oil cylinder press the spring to open valve.
- c). Close globe valve (2).
- d). When close the valve, Open the globe valve (1) & (2) After manual operation, open globe valve (1) & (2), at the meantime when it change to auto-operation way.

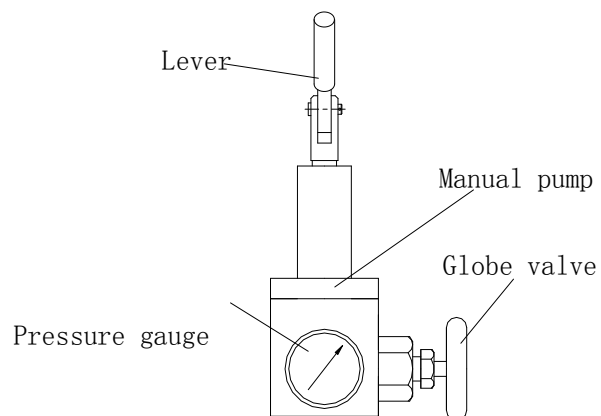
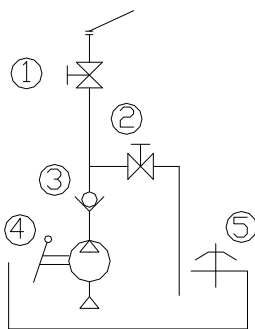

6.- Stroke Adjustment

The stroke adjustment is available from 80° to 100°

The way of stroke adjustment:

Loosened the stroke nut firstly,

a. Screw out the open direction stroke bolt, open position increased, screw in the open direction stroke bolt, open position decreased,

b. Screw out the close direction stroke bolt, close position increased, screw in the close direction stroke bolt, close position decreased

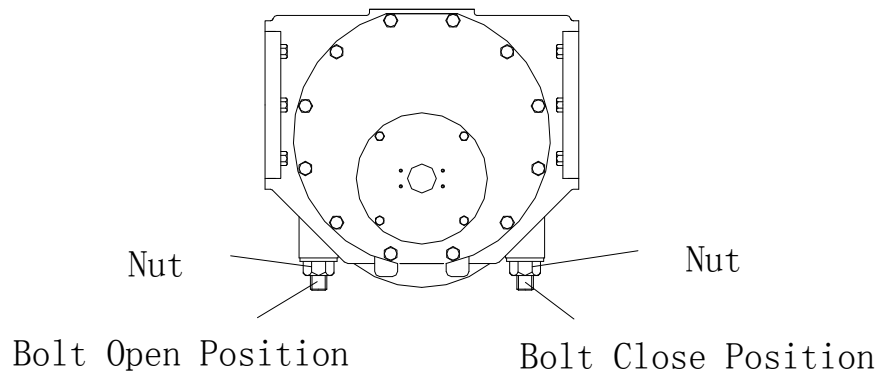

Note: Please note to tighten the bolt nut after adjusting the appropriate on/off position.



SCOTCH YOKE PNEUMATIC ACTUATORS

MMM-ACTREG-S&Y Rev.0

7.- Modular structure description

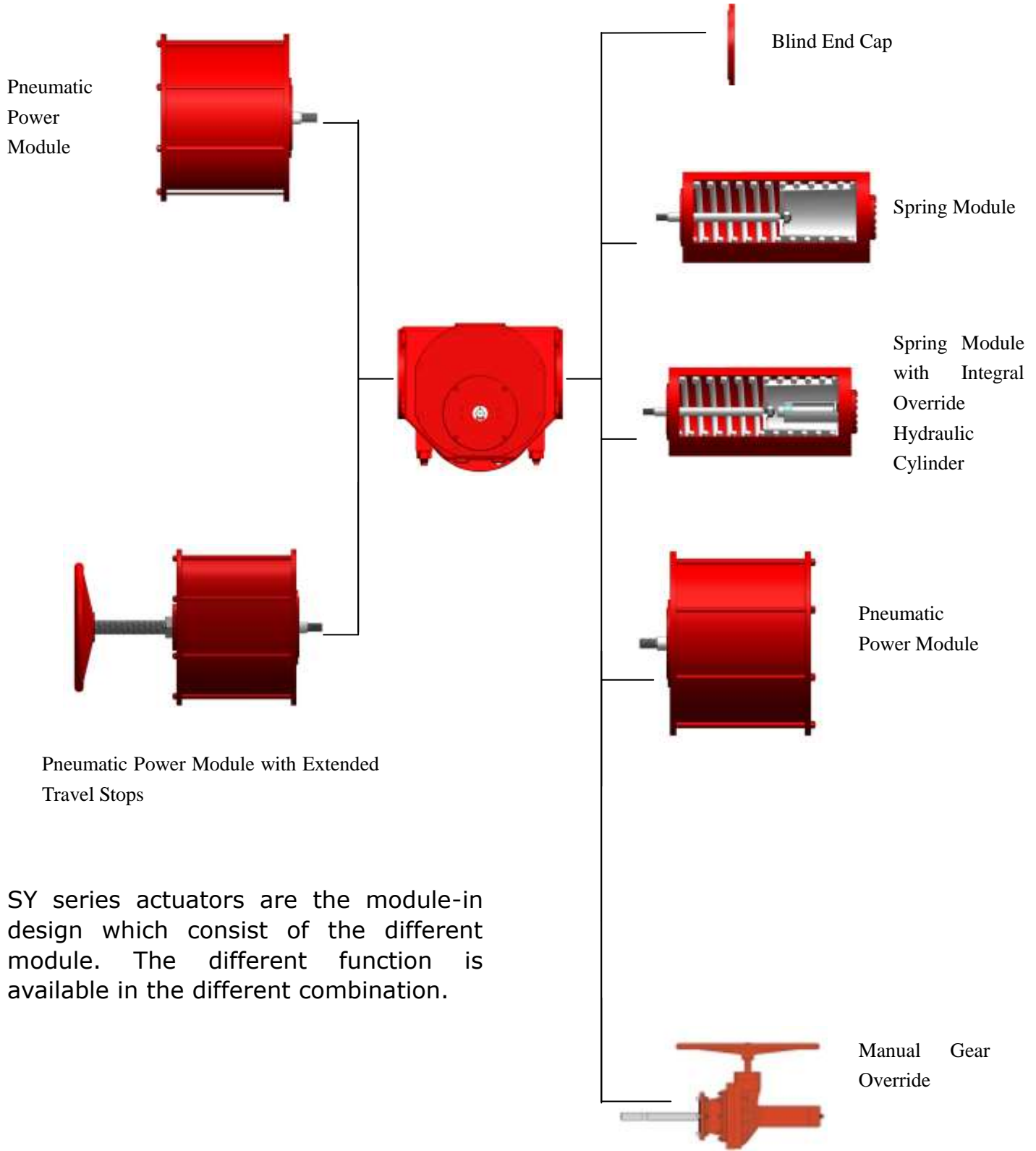

SY series actuators are the module-in design which consist of the different module. The different function is available in the different combination.

8.- Assembly Drawing & Part List

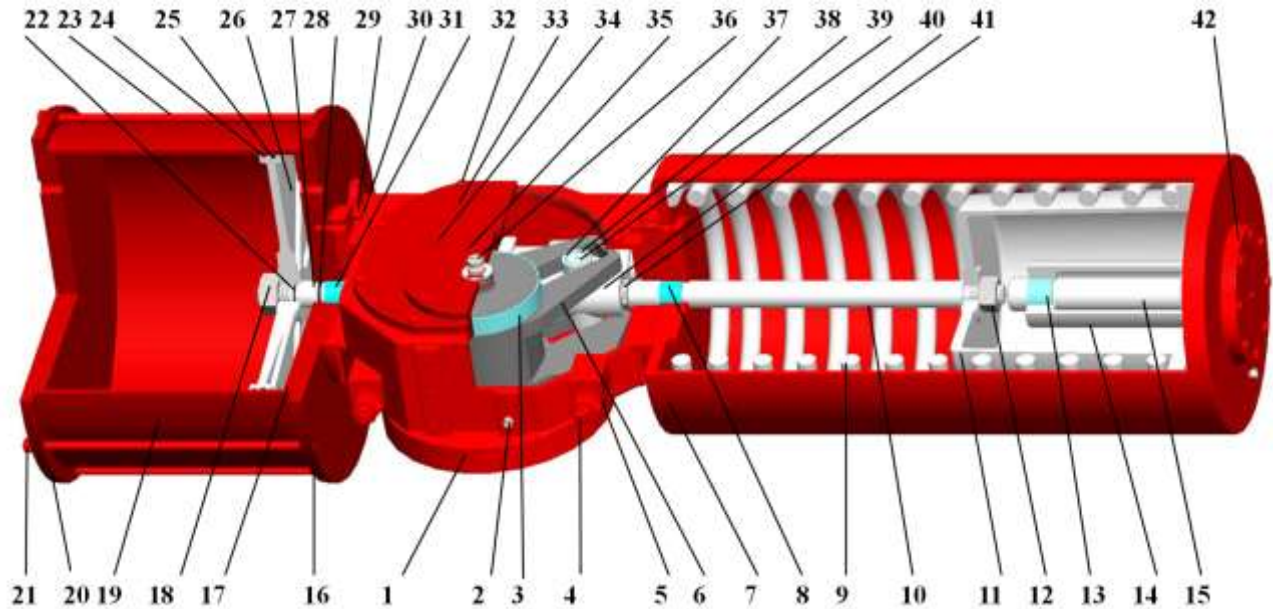

Pos.	Name	Material	Pos.	Name	Material
1	Body	Ductile Iron	22	O-Ring	NBR
2	Vent Valve	Carbon Steel	23	Screw	Alloy Steel
3	Sliding Bearing	Metal + TFE	24	Guide Ring	PTFE
4	Adjust Stud	Alloy Steel	25	O-Ring	NBR
5	Nut	2H	26	Piston	Ductile Iron
6	Yoke	Carbon Steel	27	Center Bar	Alloy Steel
7	Spring Case	Carbon Steel	28	O-Ring	NBR
8	Sliding Bearing	Metal + TFE	29	Stud	Alloy Steel
9	Spring	Alloy Steel	30	Nut	2H
10	Tension rod	Alloy Steel	31	Sliding Bearing	Metal + TFE
11	Spring Seat	Carbon Steel	32	Bolt	Carbon Steel
12	Nut	2H	33	Body Cap	Ductile Iron
13	Sliding Bearing	Metal + TFE	34	Bolt	Carbon Steel
14	Hydraulic Cylinder	Carbon Steel	35	Cover	Ductile Iron
15	Hydraulic Piston	Carbon Steel	36	Drive Shaft	Alloy Steel
16	Adapter	Ductile Iron	37	Roller	Alloy Steel
17	O-Ring	NBR	38	Sliding Bearing	Metal + TFE
18	Nut	2H	39	Pin	Alloy Steel
19	Cylinder	Carbon Steel	40	Guide Block	Ductile Iron
20	End Cap	Ductile Iron	41	Nut	Carbon Steel
21	Nut	2H	42	Cover Plate	Carbon Steel

9.- Module Replacement

9.1.- Spring return, pneumatic actuator from failure close position to failure open position

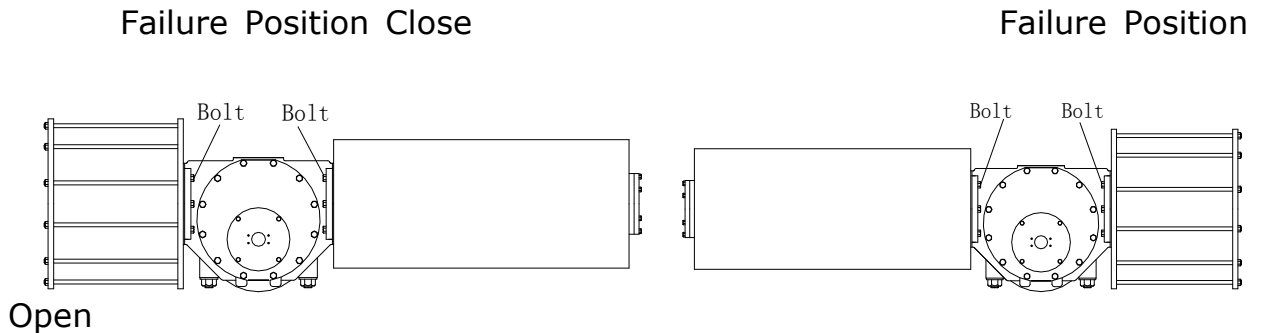

Open

Replacement Steps (refer to assembly drawings and parts list)

- 1.- Loosen the spring end cap bolts, remove the spring cover 42
- 2.- Withstand Spring rod with special tooling (see the right picture)
- 3.- Loosen the bolts on the top cover 34, remove the top cover 35
- 4.- Loosen the bolts on the body cap 32, remove the body cap 33
- 5.- Anti-clockwise rotating nut 41, Spin out it from the guide block 40, while unscrewed it from the spring center bar
- 6.- Loosen the bolts connect the spring module and body, remove the spring module
- 7.- Anti-clockwise rotating the nut connects the cylinder center bar in guide block; screw out from the guide block, while unscrewed from the cylinder center bar
- 8.- Loosen the bolts connect the pneumatic power module and body, remove the pneumatic power module
- 9.- Encase the pneumatic power module at one end of the body ever encase spring module, nut 41 to connect cylinder center bar with the guide block 40, rotating nut 41 in place
- 10.- Bolt to connect pneumatic power module with body and tighten the bolts
- 11.- Encase the spring module at one end of the body ever encase the pneumatic power module, nut 41 to connect spring case center bar with the guide block 40, rotating nut 41 in place
- 12.- Mount the body cap on body, installed the bolt connect the body cap and body, tighten the bolts
- 13.- Mount the cover on body cap, installed the bolt connect the cover and body cap, tighten the bolts.
- 14.- Screw out the trapezoidal screw in the tooling of spring end cap, to separate it from the spring seat in the spring case, loosen the bolts which installed

the tooling on spring end, remove the tooling.

15.- Installed the spring end cap, screw and tighten bolts connect body cap and cover

16.- Supply or cut off air to the actuator to check whether the drive can move smoothly

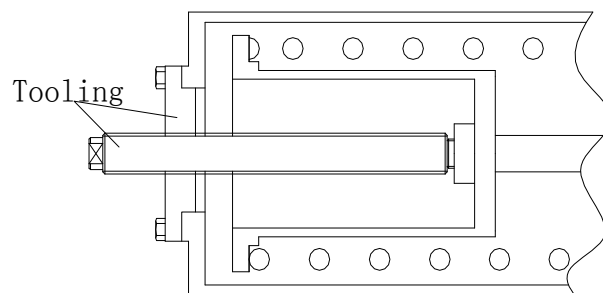

9.2.- Spring return, pneumatic actuator from failure open position to failure close position.

The same method as failure close position to failure open position.

9.3.- Change double acting type to single acting type.

Replacement Steps (refer to assembly drawings and parts list)

- 1.- Withstand Spring rod with special tooling
- 2.- Loosen the bolt which connect blind plate and body, remove the blind plate
- 3.- Loosen the bolt 34 on the cover, remove the cover 35
- 4.- Loosen the bolt 32 on body cap, remove the body cap 33
- 5.- Encase the spring module at one end of the body ever encase pneumatic power module, nut 41 to connect spring case center bar with the guide block 40, rotating nut 41 in place
- 6.- Screw out the trapezoidal screw in the tooling of spring end cap, to separate it from the spring seat in the spring case, loosen the bolts which installed the tooling on spring end, remove the tooling
- 7.- Assemble the spring end cap, then screw and tighten the bolt connecting the spring cylinder cover and spring cylinder;
- 8.- Assemble the body on the cylinder, then screw and tighten the bolt connecting the body cap and the body;
- 9.- Assemble the top cover on the body cap, then screw and tighten the bolt connecting the body cap and the top cover.
- 10.- Supply air to the actuator, and actuated it for 4~5 times to check if it

works smoothly.

9.4.- Transform the spring return type to double acting type actuator

Steps: (Please refer to the assembly chart and parts table)

- 1.- Loose the bolt on the spring end cap, and take the spring end cap 42;
- 2.- Withstand the spring piston rod with the special tool;
- 3.- Loose the bolt 34 on the top cover, and take the top cover 35;
- 4.- Loose the bolt 32 on the body cap, and take the body cap 33;
- 5.- Rotate the bolt 41 in counter- clockwise direction and back out it from the guide block 40, then take it from the piston rod.
- 6.- Loose the bolt connecting spring module and the body and remove the spring module.
- 7.- Assemble the blind plate on the body where spring module is assembled, then screw and tighten the bolt connecting blind plate and body;
- 8.- Assemble the body cap on the body, then screw and tighten the bolt connecting the body cap and body;
- 9.- Assemble the top cover on the body cap, then screw and tighten the bolt connecting the body cap and top cover;
- 10.- Supply air to the 2 air ports on the spring module of actuator, and actuate it for 4~5 times to check if it works smoothly;

9.5.- Assemble the Jackscrew on the spring module

Steps:

- 1.- Loosen the bolt on the spring end cap and take the spring end cap 42;
- 2.- Assemble the Jackscrew on the side of spring cylinder
- 3.- Screw and tighten the bolt connecting the Jackscrew and spring cylinder;
- 4.- Rotate the hand wheel on the Jackscrew and open/ close the valve for 2~3 times to check if the manual override works flexible;

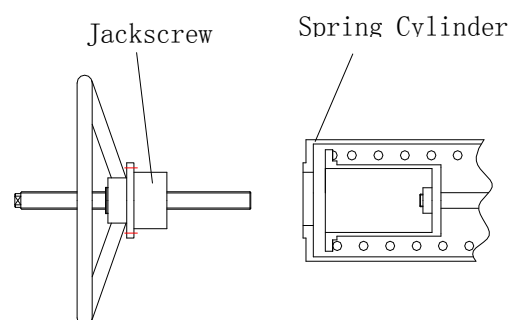

9.6.- Assemble the hydraulic manual override mechanism on the spring module

Steps:

- 1.- Loosen the bolt on the spring end cap and take the spring end cap 42;
- 2.- Put the O-ring and Stop collar in to the O-ring of hydraulic cylinder;
- 3.- Assemble the hydraulic cylinder into the spring cylinder;
- 4.- Put the O-ring into the spigot of spring cylinder side;
- 5.- Assemble the spring cylinder cover on the spring cylinder;
- 6.- Screw and tighten the bolt connecting spring cylinder cover and the spring cylinder;
- 7.- Please refer to the figure 5.2.1., assemble the manual pump on the body cap, then screw and tighten the bolt.
- 8.- Connect the stainless tube, high pressure fitting and the hydraulic cylinder;
- 9.- Add some hydraulic oil into the tank of the manual pump, then power oil to the hydraulic cylinder through operating the lever on the manual pump. Make the driving mechanism run to the full open position, and check if there is leakage and if the manual override works well;

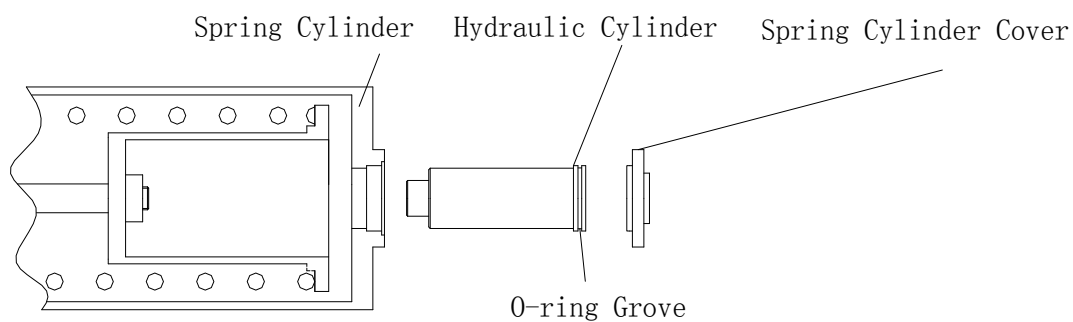

9.7.- Assemble the opening limit mechanism on the spring module

Steps:

- 1.- Loosen the bolt on the spring end cap and take the spring end cap 42
- 2.- Assemble the Jackscrew on the spring cylinder side
- 3.- Screw and tighten the bolt connecting the opening limit mechanism and spring cylinder;

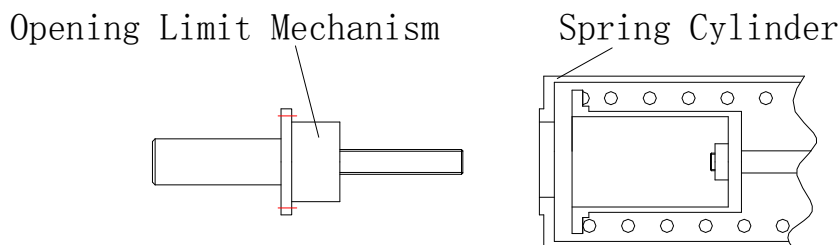

10.- Attention

10.1.- When the spring return type actuator with the Jackscrew enters into the auto-operation mode after manual operation, the trapezoid screw must be back out to the proper position.

10.2.- When the spring return type actuator with the Jackscrew enters into the auto-operation mode after manual operation, the 2 globe valves on the manual pump must be opened.

10.3.- When the double acting type actuator with the gear mechanism enters into the auto-operation mode after manual operation, the hand lever must be set to the auto position.

10.4.- Don't rotate the handwheel and or lever if the manual override is not needed.

10.5.- Confirm if the air pressure is normal before operation.

10.6.- The operation medium should be filtered dry, clean air.



SCOTCH YOKE PNEUMATIC ACTUATORS

MMM-ACTREG-S&Y Rev.0

11.- Maintenance

11.1.- First, confirm if the air pressure is normal.

11.2.- If the solenoid valve is energized and the supplied air can be shifted. If yes, please check the electric circuit.

11.3.- If the solenoid valve is energized and the supplied air can be shifted, please take the actuator from the valve and check the actuator and valve separately.

11.4.- When checking the actuator, please supply air to the actuator firstly and check if the actuator works normally and if there is leakage.

11.5.- If there is leakage, please change the seal.



SCOTCH YOKE PNEUMATIC ACTUATORS

MMM-ACTREG-S&Y Rev.0

APPENDIX 1:

JC-MI-S&Y-01E: PNEUMATIC CYLINDER OF SCOTCH YOKE ACTUATORS

SERIES: SY01Fxx-xxx

INDEX

- 1.-INTRODUCTION
- 2.-HANDLING AND STORAGE
- 3.-SETTING
- 4.-TESTS
- 5.-OPERATION
- 6.-MAINTENANCE
- 7.-TECHNICAL PROPERTIES OF THE EQUIPMENTS
- 8.-SAFETY AND USE
- 9.-MANUFACTURER



SCOTCH YOKE PNEUMATIC ACTUATORS

MMM-ACTREG-S&Y Rev.0

1.-INTRODUCTION

The pneumatic cylinders are important parts of the scotch yoke actuators. A failure in the installation, the absence of maintenance, etc could produce fractures, waste of time and high repairing costs.

2.-HANDLING AND STORAGE

As the pneumatic cylinder is a part of actuator this point refers to the whole actuator.

At the reception, the actuators must be inspected to verify that are according to the purchase order.

The unloading must be careful to avoid impacts and drops. The scotch yoke actuators must be handle with slings and hooks in the lugs placed on the upper side of the actuators.

For storage in the open must be provided a packaging to protect the actuator of the weather.

THE ACTUATORS ALLWAYS MUST BE IN HORIZONTAL POSITION.

3.-SETTING

When the actuator is installed the pneumatic cylinder must be protected to avoid impacts.

After installing the actuator will proceed to its connection. In the drawing included in this manual you will find where to plug the air connections.

Before connecting the pneumatic cylinder a visual check in the connection nipples must be done to assure that are free of dirt.

4.-TESTS

All the pneumatic cylinders of the ACTREG Scotch Yoke actuators are tested according the specifications of the 97/23/EC.

5.-OPERATION

The pneumatic cylinder has a max pressure service of 7bars, so never overcome this



SCOTCH YOKE PNEUMATIC ACTUATORS

MMM-ACTREG-S&Y Rev.0

pressure.

6.-MAINTENANCE

These cylinders are designed to reduce their maintenance.

Is appropriate an annual visual inspection.

Is appropriate to do a maintenance according the Real Decreto 2060/2008, de 12 de Diciembre, por el que se aprueba el Reglamento de equipos a presión y sus instrucciones técnicas complementarias.

In case that this equipment will be installed in another country of the CE different than Spain you must follow the regulations of the country of destination.

Check the torque of the bolting that assure the tightness of the pneumatic cylinder.

M16 – 235Nm

M20 – 457Nm



SCOTCH YOKE PNEUMATIC ACTUATORS

MMM-ACTREG-S&Y Rev.0

7.-TECHNICAL PROPERTIES OF THE EQUIPMENTS

Item	SY01F25-450	SY01F30-450	SY01F30-500	SY01F30-550	SY01F35-550	SY01F35-600
TAG	SY01F25-450	SY01F30-450	SY01F30-500	SY01F30-550	SY01F35-550	SY01F35-600
Material (Body - Covers)	A106 Gr.A -A216 WCB/WCC	A106 Gr.A - A216 WCB/WCC	A106 Gr.A -A216 WCB/WCC	A106 Gr.A -A216 WCB/WCC	A106 Gr.A -A216 WCB/WCC	A106 Gr.A -A216 WCB/WCC
Volume (L)	32	38	47	57	72	86
Max Pressure Service (bar)	7	7	7	7	7	7
Design Pressure (bar)	8	8	8	8	8	8
Test pressure (bar)	12	12	12	12	12	12
Service temperature min/max (°C)	-20 / See note1	-20 / See note 1	-20 / See note 1	-20 / See note 1	-20 / See note 1	-20 / See note 1
Fluid Group	G2	G2	G2	G2	G2	G2
Fluid Contained	Air	Air	Air	Air	Air	Air
Category / Module	II / H1	II / H1	II / H1	II / H1	II / H1	II / H1

Item	SY01F35-700	SY01F40-600	SY01F40-700	SY01F40-800	SY01F48-800	SY01F48-900
TAG	SY01F35-700	SY01F40-600	SY01F40-700	SY01F40-800	SY01F48-800	SY01F48-900
Material (Body –Covers)	A106 Gr.A -A216 WCB/WCC	A106 Gr.A -A216 WCB/WCC	A106 Gr.A -A216 WCB/WCC	A106 Gr.A -A216 WCB/WCC	A106 Gr.A -A216 WCB/WCC	A106 Gr.A -A216 WCB/WCC
Volume (L)	118	104	143	186	216	274
Max. Pressure Service (bar)	7	7	7	7	7	7
Design Pressure (bar)	8	8	8	8	8	8
Test Pressure (bar)	12	12	12	12	12	12
Service Temperature min/max (°C)	-20 / See note 1	-20 / See note 1	-20 / See note 1	-20 / See note 1	-20 / See note 1	-20 / See note 1
Fluid Group	G2	G2	G2	G2	G2	G2
Fluid Contained	Air	Air	Air	Air	Air	Air
Category / Module	II / H1	II / H1	III / H1	III / H1	III / H1	III / H1

Item	SY01F48-1000	SY01F60-800	SY01F60-900	SY01F60-1000	SY01F60-1100
TAG	SY01F48-1000	SY01F60-800	SY01F60-900	SY01F60-1000	SY01F60-1100
Material	A106 Gr.A -A216 WCB/WCC	A106 Gr.A -A216 WCB/WCC	A106 Gr.A -A216 WCB/WCC	A106 Gr.A -A216 WCB/WCC	A106 Gr.A -A216 WCB/WCC
Volume (L)	338	291	369	455	551
Max Service Pressure (bar)	7	7	7	7	7
Design Pressure (bar)	8	8	8	8	8
Test Pressure (bar)	12	12	12	12	12
Service Temperature min/max (°C)	-20 / See note 1	-20 / See note 1	-20 / See note 1	-20 / See note 1	-20 / See note 1
Fluid Group	G2	G2	G2	G2	G2
Fluid Contained	Air	Air	Air	Air	Air
Category / Module	III / H1	III / H1	III / H1	IV / H1	IV / H1



SCOTCH YOKE PNEUMATIC ACTUATORS

MMM-ACTREG-S&Y Rev.0

8.-SAFETY AND USE

- Never overcome the service pressure fixed in 7 bars.
- Never fill the pneumatic cylinder with another liquid different than air. To fill with another fluid first ask to manufacturer.
- Never transport the equipment with an internal pressure different than the atmospheric.
- Never install these equipments in nuclear plants.
- Never manipulate the bolting of the equipment because it can cause damages during the operation of the equipment.

WARNING!! It is advisable to isolate the equipment from vibration sources to avoid possible stress relief of the fasteners



VEREENIGING

Tel : +27 (0)11 397 2833
Fax: +27 (0)11 397 4700

DURBAN

Tel : +27 (0)31 579 2593
Fax: +27 (0)31 579 2562

