

Syntactic Foam, What is it and How Do You Make It

Presented by

Cliff Redus

Redus Engineering

DELIVERING KNOWLEDGE. DEVELOPING COMPETENCE.

Topics

- ✓ **Open vs. Closed Cell Foams**
- ✓ **What's the Problem with Open Cell**
- ✓ **What's a Syntactic *Foam***
- ✓ **Syntactic Foam Resins**
- ✓ **How Phil Nuytten Makes Syntactic Foam**
- ✓ **Design Objectives - R300 Syntactic Foam**
- ✓ **Syntactic Foam Selected for R300**

Open vs. Closed Cell Foams

- ✓ Open-cell foam, tiny cells of the foam are not completely closed. They are broken and air or water fills all of the “open” space inside the material.
- ✓ Closed-cell foam differs in that all of its tiny foam cells are closed and packed together. They are filled with a gas.

Open Cell Foams – at Depth



- ✓ 4" Styrofoam cup (Open Cell Foam)
- ✓ ROV to 3000 fsw
- ✓ Surface 0 psig 3000 ft
1,333 psig (93 bar)
- ✓ Cup shrivels to half of its original size.
- ✓ Monterey Bay Aquarium

Problem - Open-Cell Foams

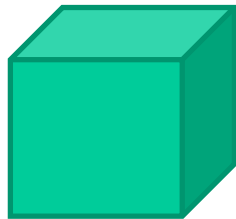
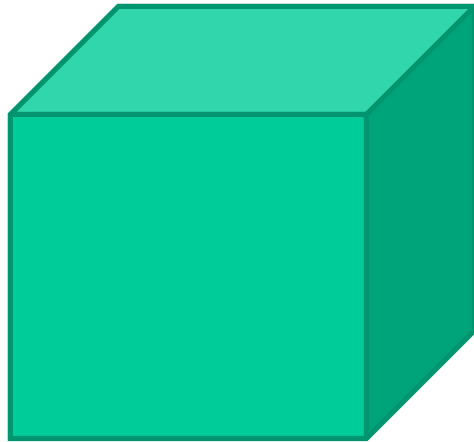

SURFACE

Displacement = Volume x Specific Weight

$$\text{Displacement} = (1 \text{ ft})^3 \times 64 \left(\frac{\text{lb}_f}{\text{ft}^3} \right) = 64 \text{ lb}_f$$

3000 fsw

$$\text{Displacement} = (0.5 \text{ ft})^3 \times 64 \left(\frac{\text{lb}_f}{\text{ft}^3} \right)$$

$$= 0.125 \text{ ft}^3 \times 64 \left(\frac{\text{lb}_f}{\text{ft}^3} \right) = 8 \text{ lb}_f$$

✓ **Lost 56 lb_f of displacement**

What is a Syntactic Foam?

- ✓ A lightweight engineered foam consisting of manufactured glass hollow microspheres and fiberglass macrospheres embedded in a resin matrix.
- ✓ Microspheres typically range from 10 to 200 microns in diameter.
- ✓ Macrospheres typically range from 1/4" to 1/2" in diameter.
- ✓ Syntactic foam has a very high compressive strength-to-weight ratio.

Why Syntactic Foam?

Alvin

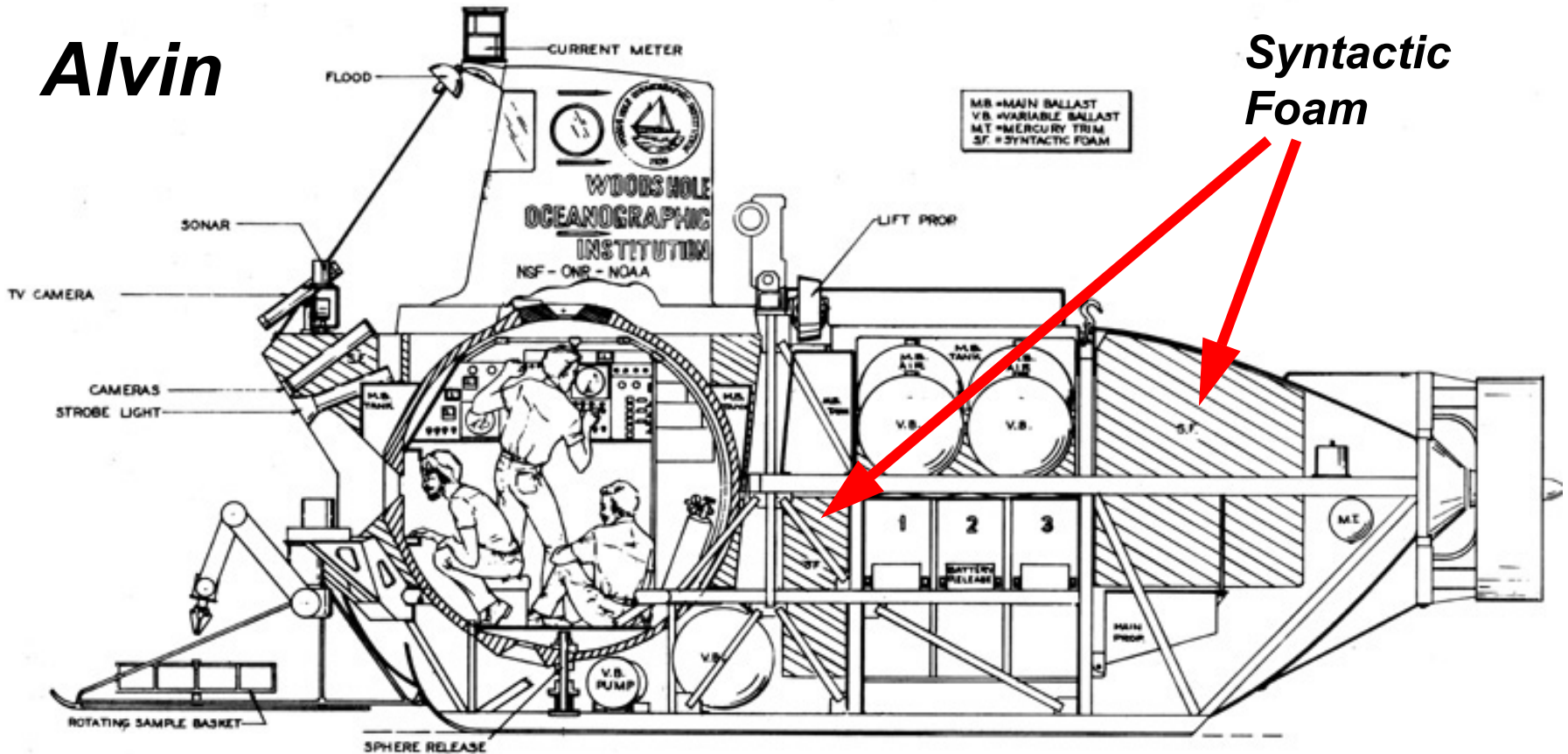

Syntactic Foam

Max Depth 14,700 ft (4500 meters)

✓ **Adds Depth Independent Buoyancy**

Syntactic Foam

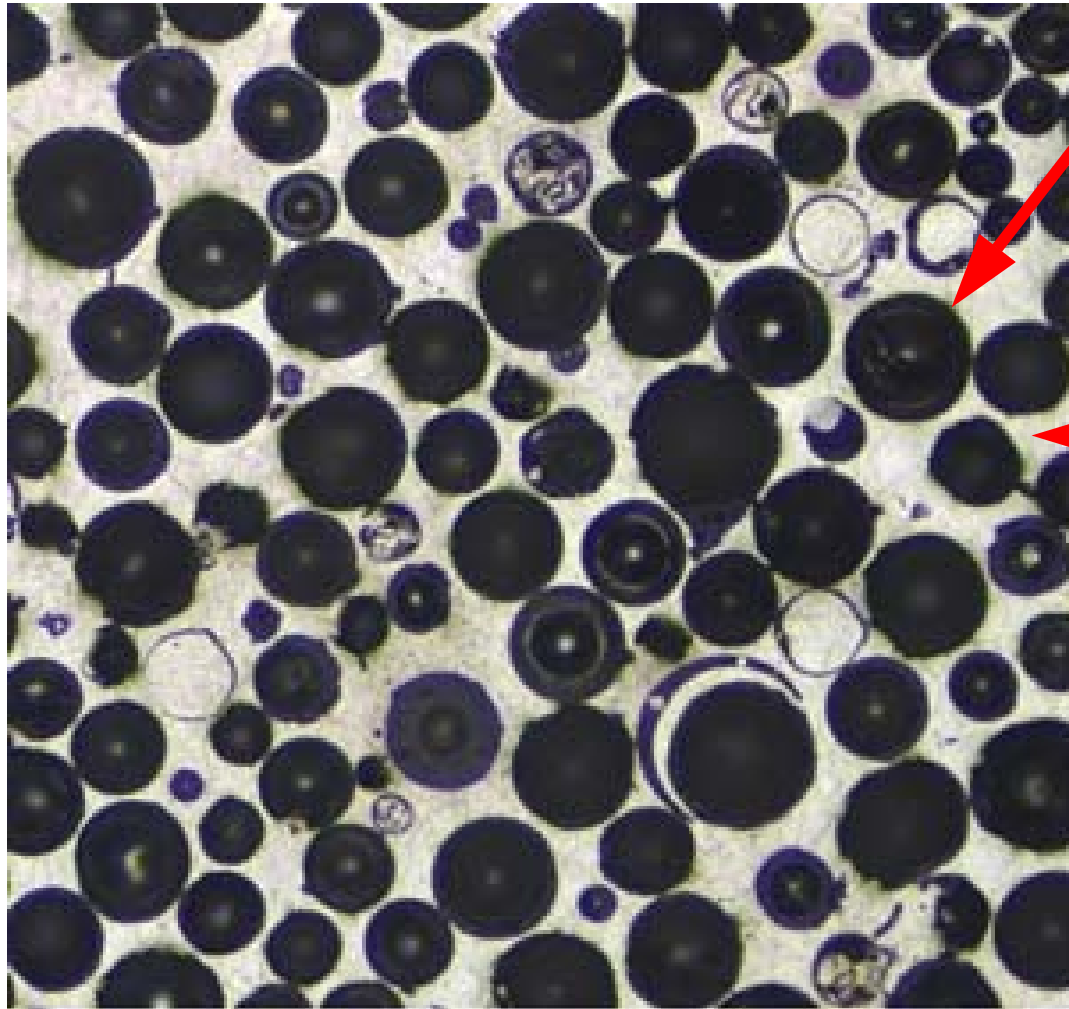

Macrospheres

*Microspheres
+ Resin*

3M Glass Bubbles

	Target Crush Strength (90% survival, psi)	True Density (g/cc)	Particle Size (microns, by volume)				Effective top size (95%)	Color (unaided eye)
			Distribution					
			10th%	50th%	90th%			
K1	250	0.125	30	65	115	120	white	
K15	300	0.15	30	60	105	115	white	
S15	300	0.15	25	55	90	95	white	
S22	400	0.22	20	35	65	75	white	
K20	500	0.20	25	55	95	120	white	
K25	750	0.25	25	55	90	105	white	
S32	2000	0.32	20	40	70	80	white	
S35	3000	0.35	10	40	75	85	white	
K37	3000	0.37	20	45	80	85	white	
S38	4000	0.38	15	40	75	85	white	
S38HS	5500	0.38	15	40	75	85	white	
K46	6000	0.46	15	40	70	80	white	
S60	10,000	0.60	51	30	55	65	white	
S60/HS	18,000	0.60	11	30	50	60	white	
iM30K	28,000	0.60	9	16	25	29	white	

$$PF = \frac{\rho_{Bulk}}{\rho_{True}}$$

- ✓ **Packing Factor varies from 55% to 68%**
- ✓ **Strength reinforced by resin (Cuming Corp)**
- ✓ **Microspheres - With rigid epoxy, six times greater strength than unsupported**
- ✓ **Macrospheres - With rigid epoxy, two times greater strength than unsupported**

Syntactic Foam Resins?

- ✓ Epoxy,
- ✓ Vinylester
- ✓ Polyester

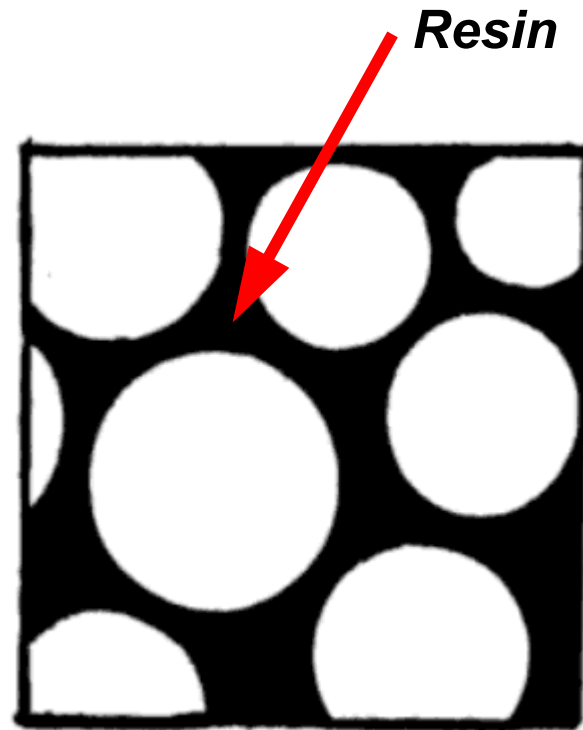

Resin - Mechanical Properties

Comparitive Tensile Strength of Resins

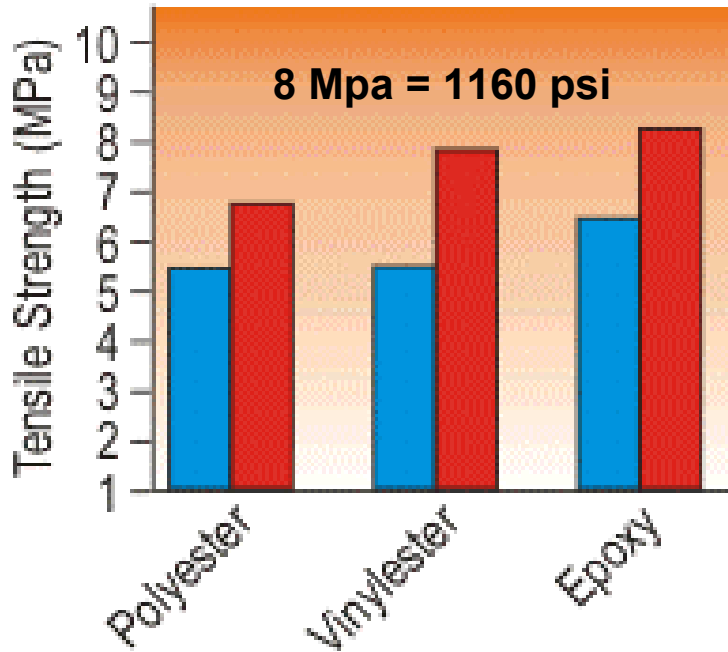

■ 7 days @ 20°C
■ 5 days @ 80°C

Comparitive Stiffness of Resins

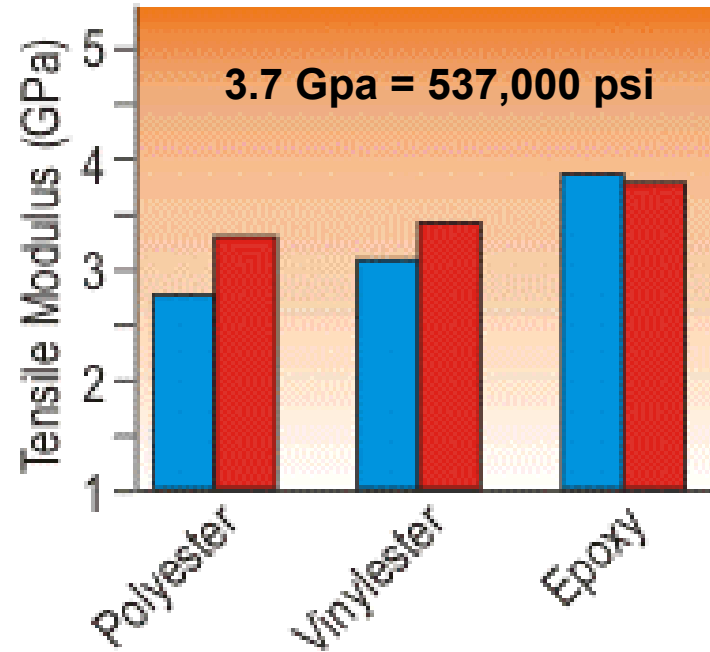

AZOM.COM™

Resin - Micro-Cracking

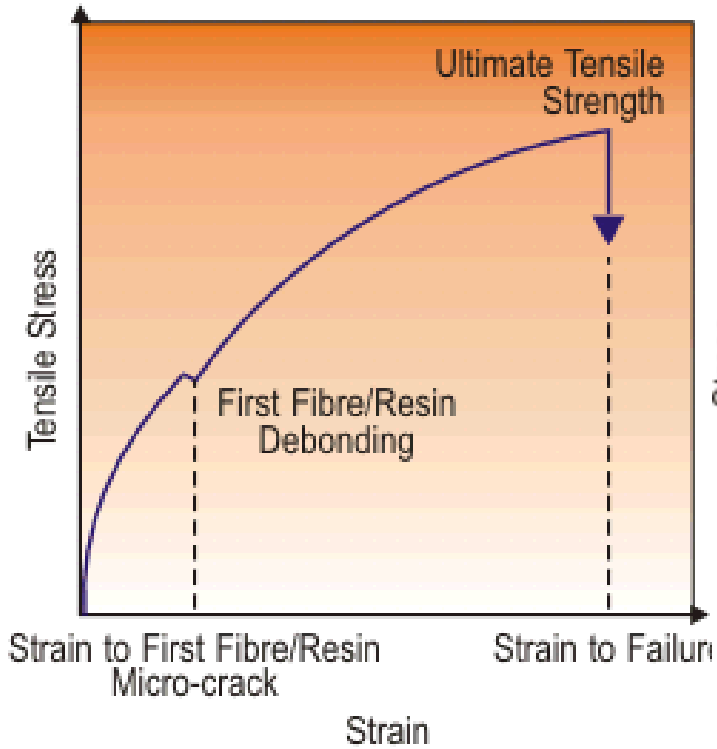

AZOM.COM™

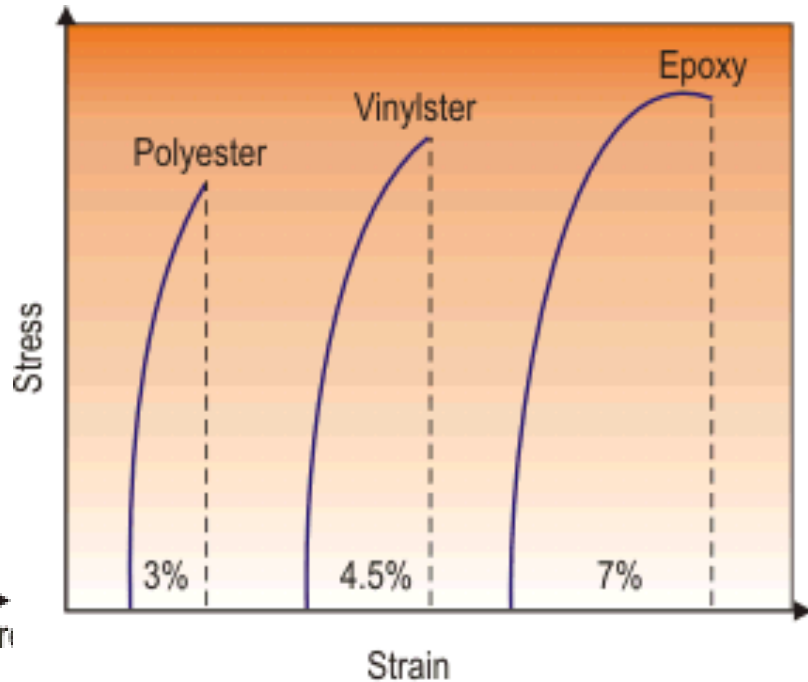

AZOM.COM™

Resin - Degradation from Water Ingress

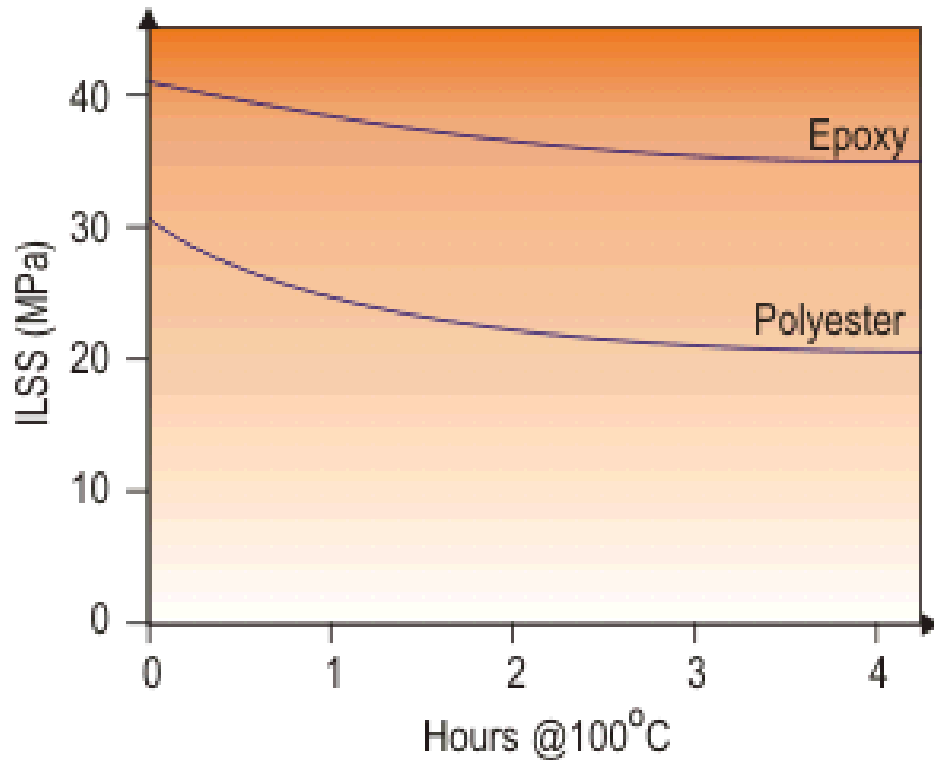

AZOM.COM™

Email - Phil Nuytten

- ✓ **Winnowing** - Glass microspheres are heavier than epoxy microspheres – but less duds. You should “winnow” either if you want absolute max efficiency – pour them into a five gallon pail of water (or bigger) with a bottom drain, agitate, let sit and the partially formed spheres will sink, drain, then pour off floaters into a shallow tray to dry.
- ✓ **Binder** - Bear in mind that the epoxy is just a binder. You shouldn't rely on it as a strength member – though, of course it is to all except the surface spheres. That means it can be the cheapest stuff you can buy in quantity. It doesn't even have to be rigid – could also be urethane, polyester, etc., although rigid foam is much easier to mount.

Email - Phil Nuytten

- ✓ **The essential thing for light foam is the use of macro-spheres in conjunction with the microspheres mix. These are epoxy spheres about the size of kids marbles. We buy them from a firm called Emerson Cummings.**
- ✓ **The biggest problem in thick castings is “Hydrotherming” you must pour in layers and allow to gel before the next one or the foam will crack. Cracked foam weeps for hours and even days after a dive and makes an awful mess.**
- ✓ **Shaping vs. Casting You can’t shape the macrosphere mass after it’s cast, because you will cut into the microspheres. Well, that is true for optimum buoyancy, but you can shape it and live with the outside layer loss – fill in the exposed partial spheres with a thixotropic microsphere/binder coating.**

We do our stuff thus:

- ✓ **Plug:** Use body putty, over a rough Styrofoam shape to wind up with a finished plug – exactly as you want the finished part to be.
- ✓ **Female Mold** Use the plug to make a conventional female mold in fiberglass. Arrange the mold so that the bottom or not seen surface/side is not sealed. Lay up gelcoat and a couple of layers of clothe/mat in the usual fashion – make this skin thin as possible while still being rigid enough to hold the foam without distorting.
- ✓ **Restrain Macrospheres** Pour a 2-3 inch layer of microspheres/binder mix. Put about 6 inches deep of macrospheres – then put a heavy cardboard or thin plywood or similar cover on top of the macrospheres. This will be cut to shape so that the macrospheres can't escape around the edges when you put weights on the cover to force the macrospheres into the microspheres mix.

We do our stuff thus:

- ✓ Done right the macrospheres will be forced to the bottom of the mold and the microspheres /binder mix will not wet the top layers of macrospheres under the cover or hold-down platform
- ✓ Building Layers - when it goes off, remove the weights and cover, turn the mold upside down and dump out the loose macrospheres. Put in another 2-3 inches layer and repeat.
- ✓ Vacuum not needed - Using this process, there is no need to vacuum the micro/binder mix. You get roughly 6 inches of build per pour - a two foot block takes four pours.
- ✓ Overheating There is not problem with overheating if you don't exceed 3 inches of microsphere/binder.
- ✓ Fabrication Time Takes about one full day to makes a set of foam blocks for a Deep Worker class sub.

Hope this helps Phil Nuytten.

R300-Syntactic Foam

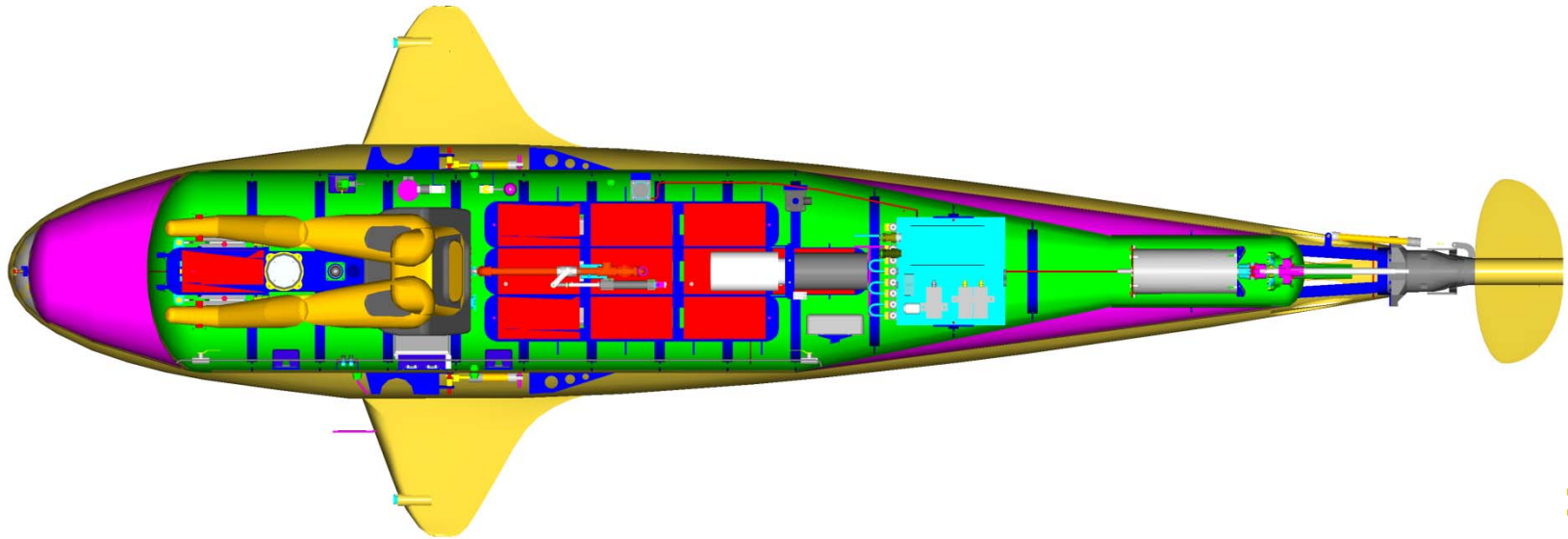

DW

hydrodynamic shell

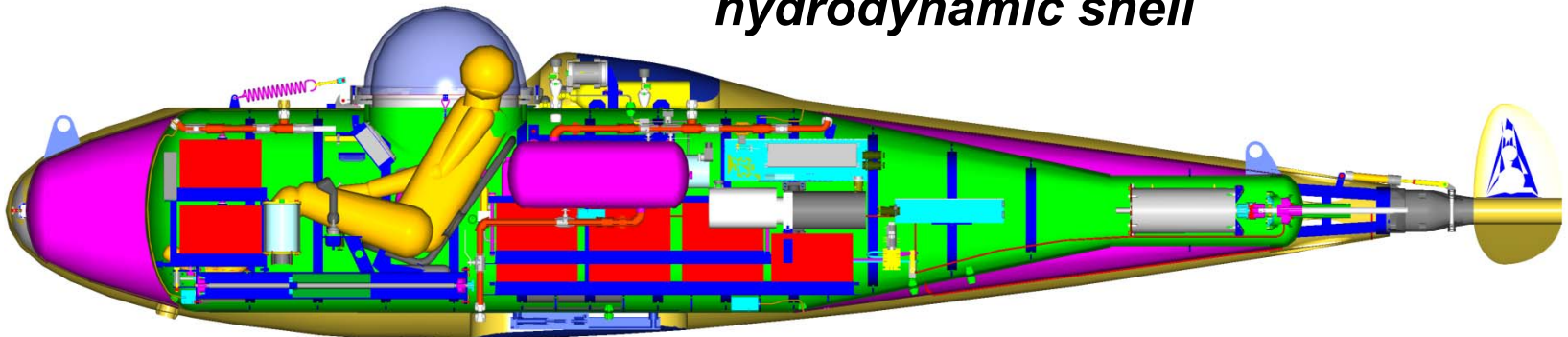

R300-Syntactic Foam

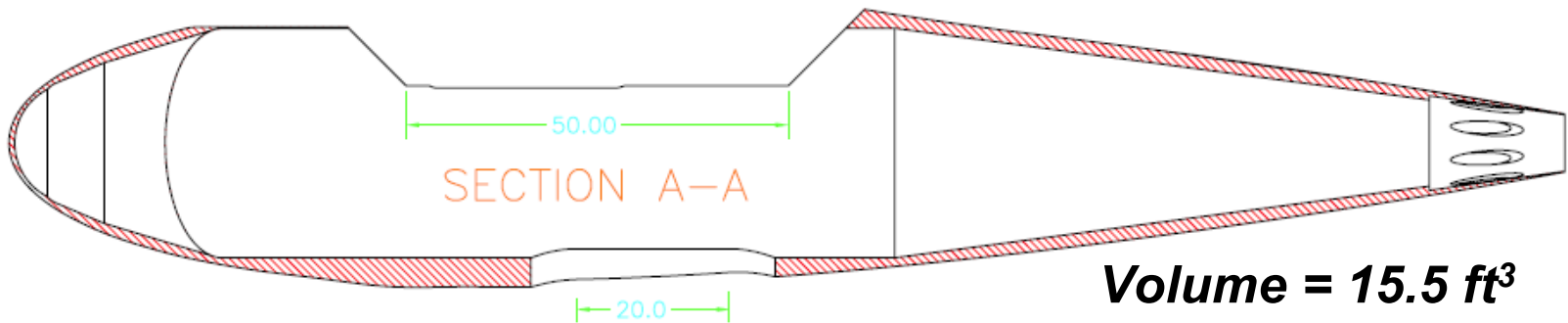
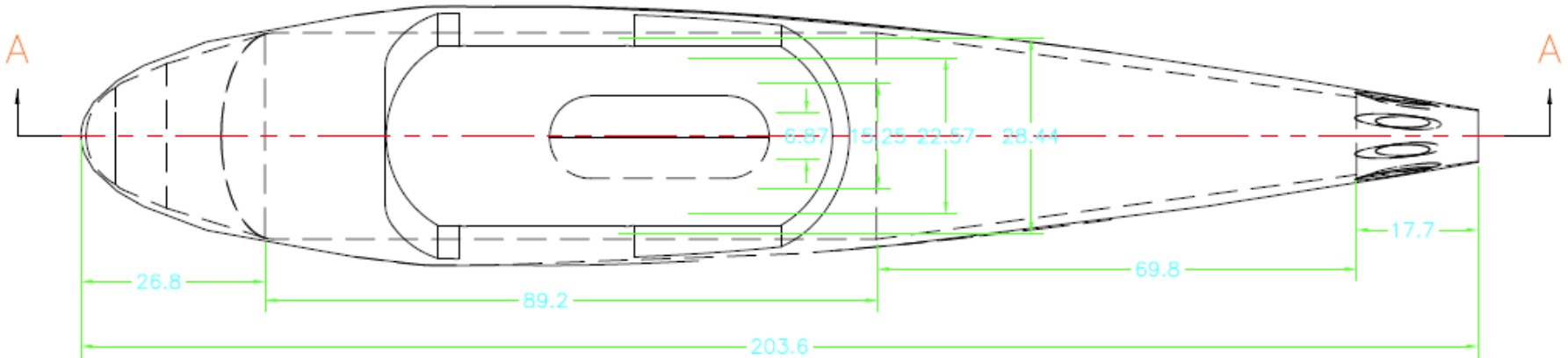

Volume = 15.5 ft³
Weight = 402 lbs
22% => Displacement = 967 lbs
Net Buoyancy = 565 lbs

SYNTACTIC FOAM PLACEMENT

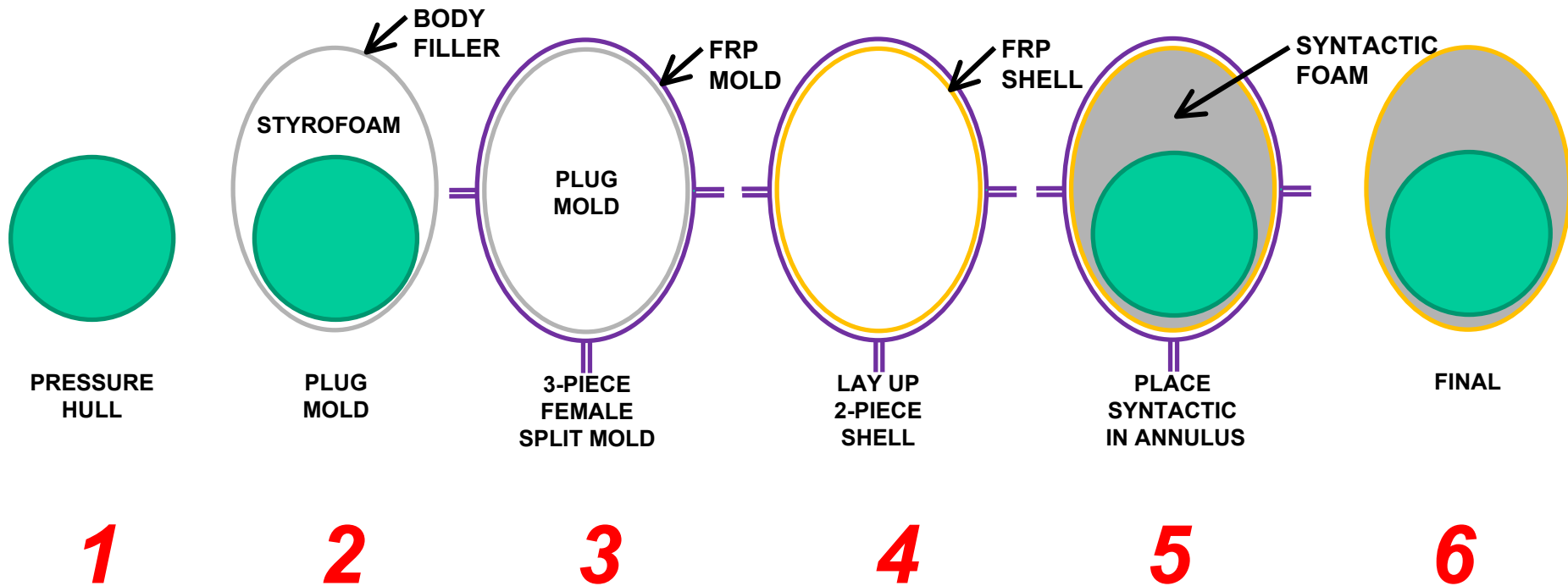

R300-Syntactic Foam

Objectives

- ✓ Target density of $26 \text{ lb}_m/\text{ft}^3$ or SG of 0.42
- ✓ Max Operating depth of 300 ft
- ✓ Slow Cure Time (2 days) to allow exothermic heat to dissipate to prevent cracking in large 16 ft^3 casting.
- ✓ Low viscosity ($< 400 \text{ cp}$) of catalyzed resin to enable resin to flow into void space
- ✓ Structurally strong enough to support boat on trailer

R300-Syntactic Foam

- ✓ Microspheres 3M K1, unsupported crush strength 250 psi, reinforced crush strength 1500 psi with rigid epoxy binder
- ✓ Macrospheres - Cumings Corp BA-38 1/4-3/8" 12-15 lb_m/ft³, unsupported crush strength 500 psi, reinforced crush strength 1000 psi
- ✓ Resin - Ribelin Huntsman Araldite GY-9667 with
- ✓ Catalyst - Huntsman Jeffamine D-230
Polyoxypropylenediamine
- ✓ Resin:Catalyst Weight Ratio 100:29.46
- ✓ Vol Mix Ratio - microspheres/resin of 1.5

Syntactic Foam – R300

Syntactic Foam

Resin	Volume of Syntactic Foam (ft ³)	15.5
	SG of Part A	1.100
	SG of Part B	0.948
	Viscosity Part A @ 77 F (cp)	500
	Viscosity Part B @ 77 F (cp)	9
	Part A by weight	100.0
	Part B by weight	29.46
	Fraction of Part A by wt	0.77
	Fraction of Part B by wt	0.23
	Fraction of Part A by Vol	0.75
	Fraction of Part B by Vol	0.25
	Density of Resin (lbm/ft ³)	66.2
	Mixture Viscosity (cp) @ 77 F	375
Macro and Micro Spheres	SG of Microsphere(true)	0.125
	SG of Macrosphere(true)	0.216
Mixture Fractions	Fraction of Microspheres by volume	0.193
	Fraction of Macrospheres by volume	0.550
	Fraction of Resin by volume	0.257
	Foam Mixture Density (lbm/ft ³)	25.9

Foam Density

Volume Required Resin Properties

Masses	Mass of Microspheres (lbm)	23.32
	Mass of Macrospheres (lbm)	114.90
	Mass of Resin (lbm)	263.95
	Mass of Resin Part A (lbm)	203.88
	Mass of Resin Part B (lbm)	60.06
	Mass of Foam	402.17
	Mass Mix Ratio - microspheres/resin	0.0883
Volumes	Packing factor for microspheres	0.50
	Bulk Volume of Microspheres (gals)	44.72
	True Volume of Microspheres (gals)	22.36
	Packing factor for macrospheres	0.55
	Bulk Volume of Macrospheres (gals)	115.94
	Volume of Macrospheres (gals)	63.77
	Volume of Resin Part A	22.22
	Volume of Resin Part B	7.59
	Volume of Resin mixture (gals)	29.81
	Bulk Vol Mix Ratio - microspheres/resin	1.5000
Cost	Cost/pound - Microspheres	\$6.80
	Cost/pound - Macrospheres	\$4.79
	Cost/gal - Resin	\$25.00
	Cost - Microspheres	\$191.60
	Cost - Macrospheres	\$1,500.00
	Cost - Resin	\$745.32
	Total	\$2,436.92

Mixture Fractions Cost

PF's

Unit Cost

Vary to get

\$157/ft³

Volume Ratios – Microspheres to Resin

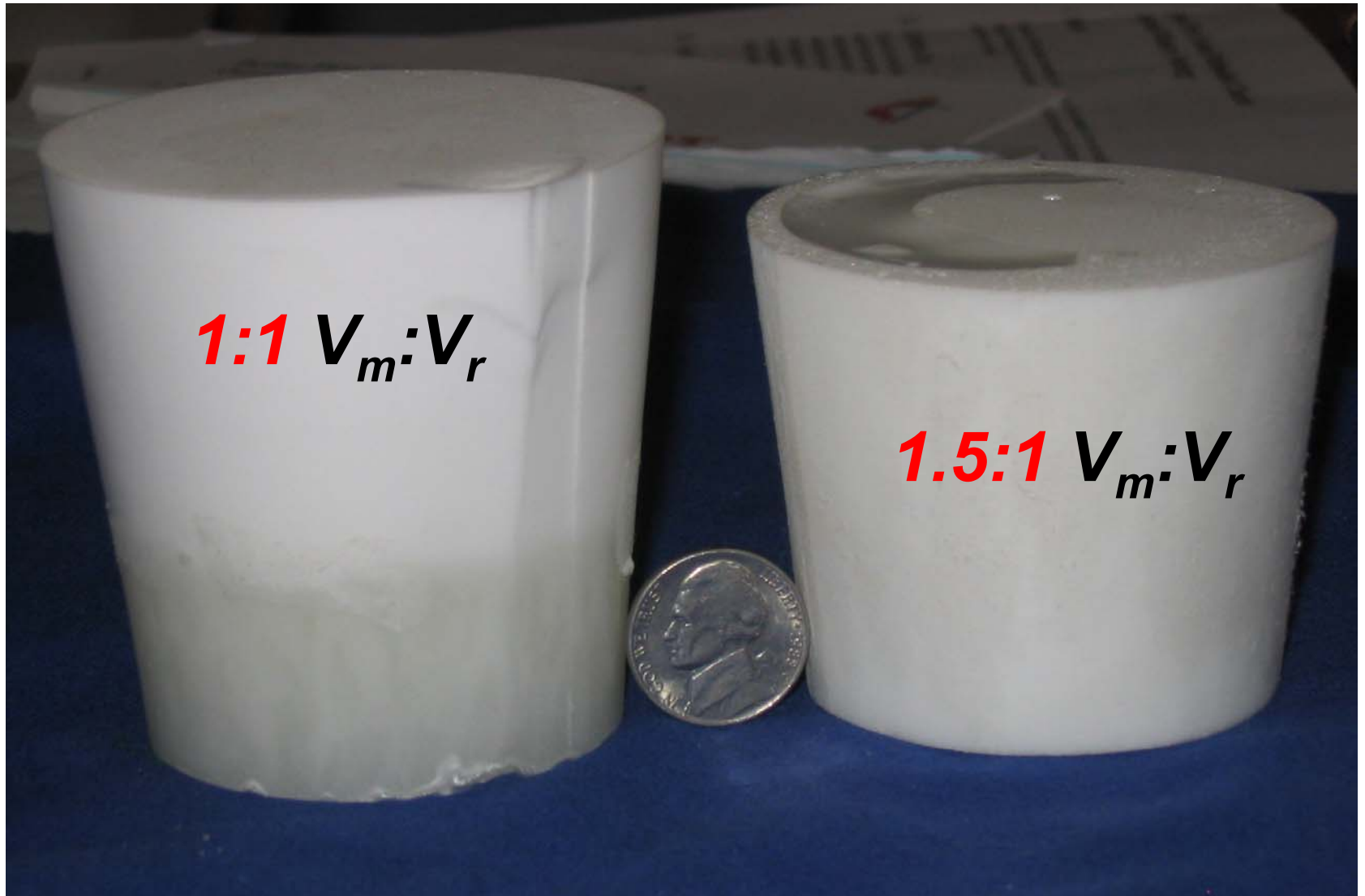

Bench Testing Macro + Micro + Resin



Bench Testing



Bench Testing



#1
8-7-06 GY-9667+D-230
+ K1
1.5:1 V:V (BULK) K1: RESIN
 $\rho = 26.4 \text{ LB/FT}^3$



#2
8-7-06 GY-9667+D-230
+ K1
1:1 (BULK) K1: RESIN
 $\rho = 29.7 \text{ LB/FT}^3$

Pressure Hull



Plug Mold – Expanded Polystyrene



Plug Mold - Body Filler Over EPS Foam



Completed Plug Mold

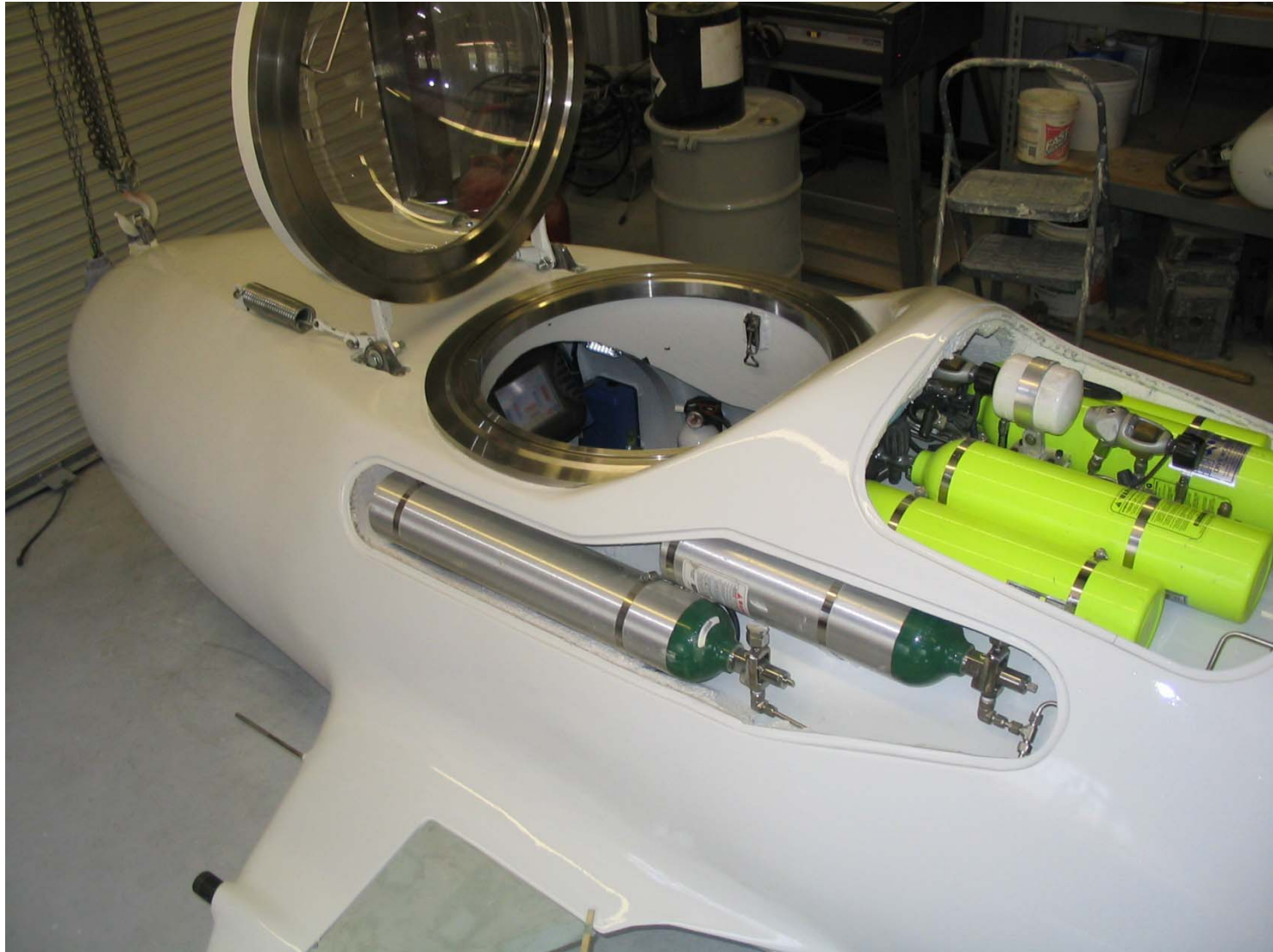

Split Mold After Removing From Plug



Female Split Mold Taken from Plug Mold



Preparing to Lay up FRP Shell



FRP Shell – Bottom Half



After Filling with Syntactic Foam



R300 on Trailer



Conclusions

- ✓ **Syntactic foam can be made in a garage but is expensive**
- ✓ **Engineered material tailored to need**
- ✓ **Macrospheres are key to low density**
- ✓ **Sphere diameters and thickness are depth dependent**
- ✓ **“Winnowing” required for max efficiency**
- ✓ **Binder – Polyester is lower cost but weaker**
- ✓ **Binder – Epoxy is stronger but more costly**
- ✓ **“Hydrotherming” issue for large castings**