

Syracuse University

Brand Guidelines



Introduction

Syracuse University embarked on a Universitywide initiative to clarify what we stand for, how we're different and why audiences should engage with us. To better understand our audiences and crystallize our positioning, we conducted extensive research among current and prospective students, parents, high school counselors, faculty, staff, partners, key stakeholders and leadership across schools, colleges and programs.

These conversations culminated in the development of a refocused strategy, reenergized messaging and a refreshed visual identity. Applied together, these elements will help Syracuse University drive deeper understanding, more meaningful connections, broader support and greater impact.

As we look to the future of Syracuse University, we are all responsible for telling our story in a clear, compelling and cohesive way. These shared resources can help us all understand, own and implement our identity with consistency, so we can realize our One University vision—and the full potential of the entire Syracuse University community. Our visual identity guidelines offer insight into the creation and intention of each element, as well as direction on their application.

Table of Contents

1 What We Stand For

1.1 Brand Platform	5
Positioning	6
Pillars	7
Priorities	7
Personality	8

2 University Identifiers

2.1 Primary Logo	10
Lockups	11
Clear Space	12
Minimum Size	13
Color Variations	14
Logo Misuse	15
Configurations	16
Alternative Configurations	16
2.2 Block S	
Standard	17
Amplified	17
2.3 Heritage Logo	18
2.4 Typography	
Brand Fonts	19
System Fonts	20
Structure	21
Grids and Layout	22
2.5 Color Palette	23
Color Accessibility	24
2.6 Supergraphics	
Block S	26
Laurel	28

3 Imagery

3.1 Iconography Styles	31
Design	32
Categories	33
3.2 Data Visualization	34
3.3 Illustration Styles	35
Full Color	36
Duotone	37
1-Color	37
Architectural	38
3.4 Photography	39
Our Style	40
Other Creative Considerations	41
3.5 Videography	42
Our Brand Story	43
Our Style	44
Other Creative Considerations	45
3.6 Social Media	46

4 Design Inspiration

4.1 Inspiration	47
Expressions Dial	48
Posters	49
Magazine	50
Guide	51
Merchandise	52
Digital	53
Environmental	54



WHAT WE STAND FOR

Overview

The Syracuse University identity is grounded in the academic strategic plan and guided by our brand strategy—which serves as a lens for the way we think, act and communicate.

As we look to the future, our strategy will help inform our experiences and inspire our expressions, bringing our story to life in a way that is bold, boundless, welcoming and transformative.

Brand Platform

Our brand strategy is a lens that guides how we think, act and communicate.

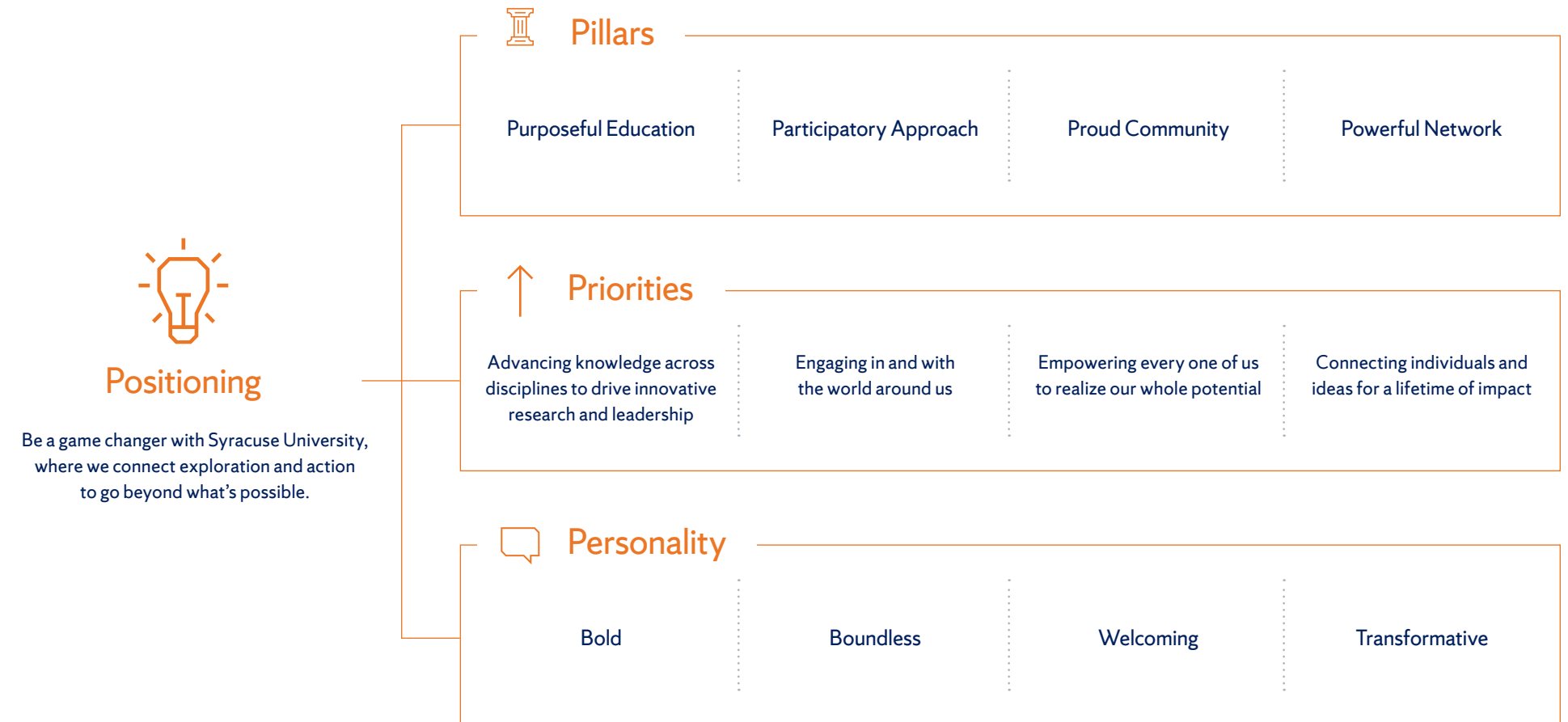

Brand Platform



Positioning

Crystallizes what we stand for, how we're different and why audiences should engage with us.

**Be a game changer with Syracuse University,
where we connect exploration and action
to go beyond what's possible.**

Defines who we attract and advance— and makes it personal
Addresses the need for resourceful, responsive leaders
Honors the impact of individuals and the community
Bridges our academic and athletic drive

Speaks to the power of our community and participatory culture
Captures how we bring together diverse individuals, interests and ideas
Balances limitless discovery with real world applicability
Reflects students' desire to explore and grow beyond the classroom

Highlights how we push beyond what we know
Conveys how we challenge the status quo
Reframes how we realize the potential of every student in relevant terms

Brand Platform



Pillars

Our brand strategy is a lens that guides how we think, act and communicate.



Priorities

Areas of focus that drive our actions and help us realize our One University vision.

Purposeful Education

Advancing knowledge across disciplines to drive innovative research and leadership

Participatory Approach

Engaging in and with the world around us

Proud Community

Empowering every one of us to realize our whole potential

Powerful Network

Connecting individuals and ideas for a lifetime of impact

Brand Platform



Personality

Our distinctive voice, which sets the tone and style of our communications both visually and verbally.

		We are...	But never...
Bold	<p>We strive to go to the edge of possibility, and then keep going. We are resourceful, resilient and always ready to turn obstacles into opportunities.</p> <p>Our communications have a point of view and get to the point.</p>	<p>Tenacious</p> <p>Visionary</p> <p>Purposeful</p>	<p>Stubborn</p> <p>Lofty</p> <p>Pushy</p>
Boundless	<p>We open ourselves to new perspectives and actively engage with the world around us.</p> <p>Our communications illuminate unexpected insights, ideas and connections.</p>	<p>Open</p> <p>Active</p> <p>Curious</p>	<p>Unfocused</p> <p>Exhausting</p> <p>Unserious</p>
Welcoming	<p>We're a community that empowers and uplifts every one of us to realize our whole potential.</p> <p>Our communications harness our spirit, showing the world what Orange can do when united.</p>	<p>Approachable</p> <p>Unifying</p> <p>Uplifting</p>	<p>Undiscerning</p> <p>Uniform</p> <p>Trite</p>
Transformative	<p>We connect ideas, interests and individuals to expand personal and collective impact.</p> <p>Our communications amplify how we spark and scale positive change.</p>	<p>Mobilizing</p> <p>Dynamic</p> <p>Inspiring</p>	<p>Forced</p> <p>Frenetic</p> <p>Insincere</p>



UNIVERSITY IDENTIFIERS

Overview

Syracuse University's visual identity is bold and dynamic, reflecting how we connect exploration and action to go beyond what's possible.

Our toolkit includes our logo, color palette, typography and graphic elements, creating a distinct visual language that can be used in a variety of ways.

By establishing foundational elements that can be flexed across contexts and channels, these guidelines help us show, and not just tell, Syracuse University's story of impact.

Primary Logo

The Syracuse University logo is a powerful symbol of the individual and collective impact of our students, faculty, staff, alumni, partners and broader community.

When applied consistently, it elevates and enhances our brand recognition, relevance and reach.

Our logo consists of two key elements: our logo symbol, which we call the **Block S**, and our full name set as a **wordmark**.



Symbol

Syracuse University

Wordmark

Symbol

As our boldest and most recognizable asset, the Block S is the focal point of our logo. When appearing in the context of our logo—either as a lockup or relationship—always use the standard Block S (i.e., solid with no outline).

For more information on how to apply approved variations of our Block S, see page 17. For guidance on how to use the Block S as a supergraphic, see page 26.

Wordmark

Our official wordmark is typeset in Sherman Serif Book. The letters of our wordmark have been set with specific spacing and weighting, which cannot be recreated by simply typing it out. Therefore, when the wordmark appears as part of the logo—either as a lockup or relationship—always use the official artwork.

Our name also appears within headlines, messages or supporting copy. In those instances, the wordmark should not be embedded within text. Instead, type out our name and follow the typography recommendations on page 21.

Primary Logo

Lockups



Horizontal, one-line (preferred)
Where space permits, this version is preferred.



Horizontal, two-line
This configuration can be used when horizontal space is limited, and the one-line variation is not legible.



Stacked, one-line
When size or space constraints do not allow for horizontal configurations, this version can be used.



Stacked, two-line
When size or space constraints do not allow for horizontal or stacked one-line configurations, use this version.

Primary Logo

Clear Space

To protect its integrity and impact, always consider the placement and prominence of our logo within layouts.

Keep the logo clear of competing text, images and graphics by maintaining the minimum amount of clear space, equal to the width of the “S” on all sides.

The space between the symbol and wordmark is equal to width of the letter “y” from the wordmark.

Horizontal

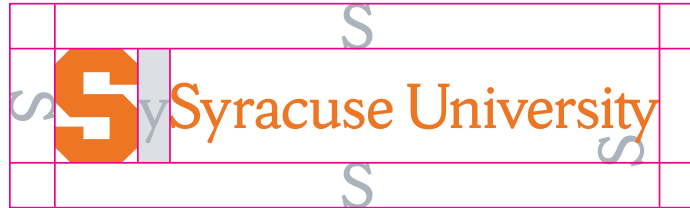

Stacked

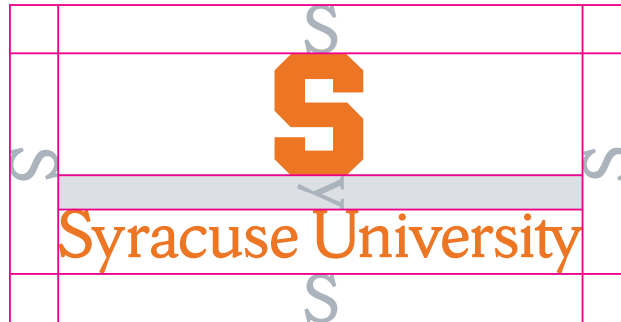

Primary Logo

Minimum Size

Ensure legibility of our logo by using at least the minimum size for each configuration.

Horizontal, one-line (preferred)

For our preferred logo lockup, the minimum size is a width equal to or greater than 1.5" for print and 150px for digital applications.

Horizontal, two-line

For this configuration, the minimum size is a width equal to or greater than 1.0" for print and 100px for digital applications.

Stacked, one-line

For this version, the minimum size is a width equal to or greater than 1.25" for print and 125px for digital applications.

Stacked, two-line

The minimum size for this version is a width equal to or greater than 0.625" for print and 65px for digital applications.

Horizontal



Print 1.5"
Digital 150px



Print 1.0"
Digital 100px

Stacked



Print 1.25"
Digital 125px



Print 0.625"
Digital 65px

Primary Logo

Color Variations

Orange (preferred)

As our primary University color, Syracuse University

Orange is the preferred color for the logo. Use this

version whenever possible.



Knockout (white)

To avoid brand confusion with peer institutions and comply with legal requirements, the knockout version must always include both the Block S and wordmark.

This version should only be applied on dark backgrounds or images where the preferred version lacks contrast. Avoid overlaying the logo on photography in ways that obstruct the subject.

Primary Logo

Logo Misuse

Our logo is the most recognizable representation of our brand. As such, it should not be altered under any circumstances. Here is a partial list of things to avoid:

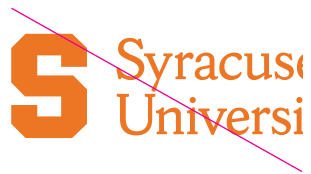

1. Don't crop the logo.



2. Don't recolor the logo.



3. Don't alter the logo.



4. Don't rotate the logo.



5. Don't scale or manipulate the logo proportions.

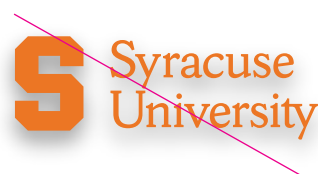

6. Don't add a drop shadow to the logo.

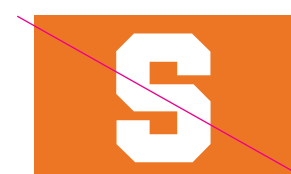

7. Don't apply the knockout version of the Block S without our wordmark.

Primary Logo

Configurations

When applying our primary logo lockups, consider placements that allow our logo to shine.

Lockups can appear on the top or bottom of layouts, ideally left-aligned or centered. However, if the composition warrants it, a lockup can be right-aligned. For approved variations when used as a supergraphic, see page 26.

Our logo should command attention as the most prominent graphic element in any layout. It should never be placed haphazardly or arbitrarily, and all surrounding elements should complement it.

This page offers a few examples of how to create a connection between these two elements in both horizontal and stacked lockup configurations.

Here are some examples in which our wordmark can stand out on a page:

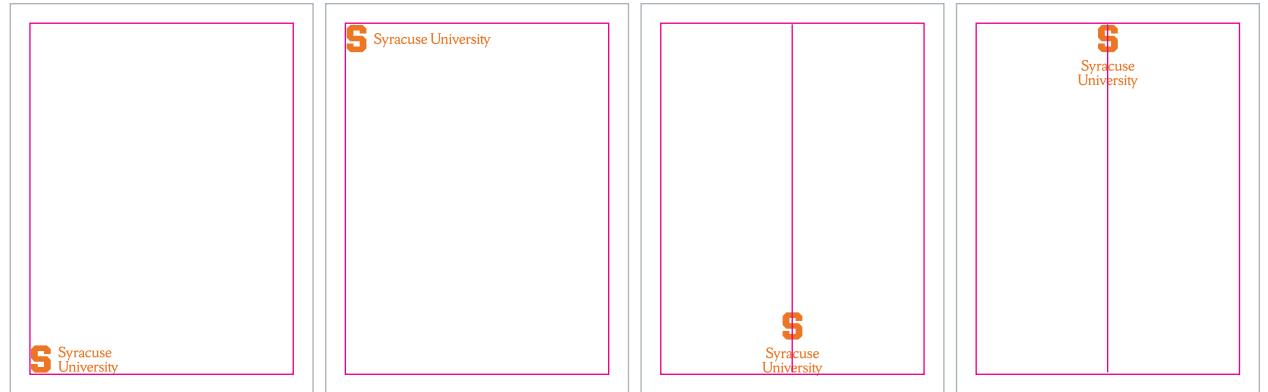

Alternative Configurations

Where space and surrounding elements require it, you can apply the standard Block S and official wordmark separately, as long as they have a clear relationship.

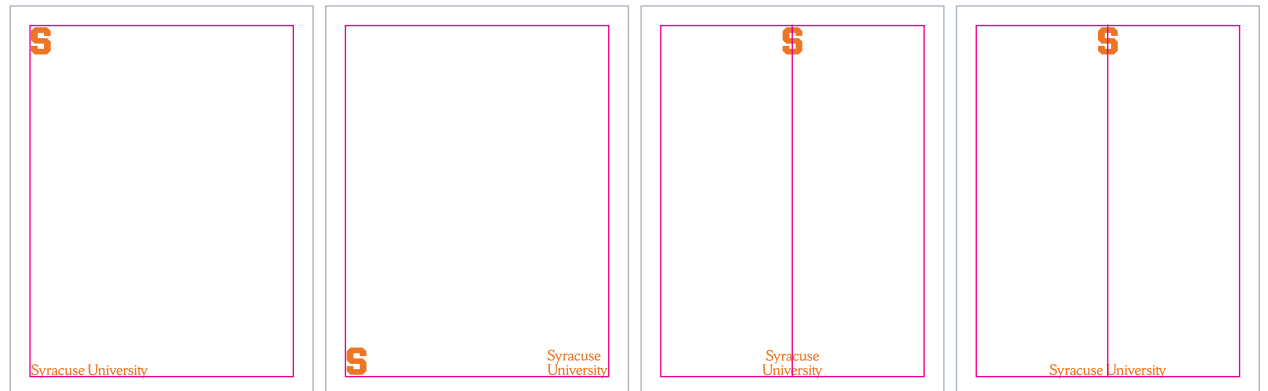

Block S

Standard

Our standard Block S is solid and does not contain an outline. This version should be applied in most contexts, ideally in Syracuse University Orange. The standard Block S is the only version approved for use in our logo lockups. For approved variations when used as a supergraphic, see page 26.



Amplified

In environments where high contrast is required (e.g., basketball court, broadcast television) or where our school spirit and pride are heightened (e.g., athletics, athletic apparel), the amplified Block S may be used. While the amplified Block S can be applied in the context of athletics, it should not appear in a lockup for Syracuse University overall or its schools and colleges.



Amplified Variations



Heritage Logo

While our primary logo should be applied in most contexts, the heritage logo can be a powerful way to elevate our prowess and prestige.

Our heritage logo combines our laurel, University motto and founding date in the form of a seal. While our primary logo should be applied in most contexts, the heritage logo can be a powerful way to elevate our prowess and prestige. Environments could include academic ceremonies (e.g., convocation), achievements (e.g., diplomas, certificates) and awards.

Like our primary logo, our seal has been optimized to conform with modern production methods, with special attention paid to the thickness and relationships of type and lines. Therefore, only use the approved artwork. The heritage logo should never be altered or recreated.

The minimum size for the heritage logo is a width equal to or greater than 1.0" for print and 100px for digital applications.



Typography

Brand Fonts

Sherman is our official brand font. There are two primary categories in the Sherman family: Sherman Serif and Sherman Sans. Both include book and bold styles, as well as italics.

As a bolder, fresher and more welcoming font, Sherman Sans should be used prominently in our communications, with Sherman Serif playing a supportive and selective role. Sherman Serif can also be used in contexts where we want to emphasize our academic strength and gravitas.

Sherman is available in a variety of weights, offering flexibility for a wide range of applications and contexts. The italic style should be used sparingly for callouts, testimonials and emphasis within body copy.

When representing our brand, no other typeface should be used in proximity to or in combination with these fonts, unless approved.

Visit [syracuse.edu/brand](https://www.syracuse.edu/brand) to download the Sherman font family.

Sherman Sans Bold

ABCDEFGHIJKLMNOPQRSTUVWXYZ
abcdefghijklmnopqrstuvwxyz
1234567890!@#\$%^&*()

Sherman Sans Book

ABCDEFGHIJKLMNOPQRSTUVWXYZ
abcdefghijklmnopqrstuvwxyz
1234567890!@#\$%^&*()

Sherman Serif Book

ABCDEFGHIJKLMNOPQRSTUVWXYZ
abcdefghijklmnopqrstuvwxyz
1234567890!@#\$%^&*()

Typography

System Fonts

When sending native documents to external stakeholders or audiences who do not have the Sherman font family installed, our preferred system fonts should be used—Verdana in place of Sherman Sans and Georgia in place of Sherman Serif. Examples of applications include: Microsoft PowerPoint, Word and Excel, Google documents and email.

Verdana Bold

ABCDEFGHIJKLMNOPQRSTUVWXYZ
abcdefghijklmnopqrstuvwxyz
1234567890!@#\$%^&*()

Verdana Regular

ABCDEFGHIJKLMNOPQRSTUVWXYZ
abcdefghijklmnopqrstuvwxyz
1234567890!@#\$%^&*()

Georgia Regular

ABCDEFGHIJKLMNOPQRSTUVWXYZ
abcdefghijklmnopqrstuvwxyz
1234567890!@#\$%^&*()

Typography

Structure

Together, our typography and color palette can create clean, clear and impactful messaging.

The following is an example of how to apply typography and color to establish a messaging structure.

To exemplify our voice, use Sherman Sans for hero messages and headlines, and Sherman Serif for subheadlines. Always use approved color combinations to meet our web accessibility standards (see page 24), and avoid using orange for body copy.

Sherman Sans
Bold

Sherman Serif
Book

Sherman Sans
Book

Sherman Sans
Bold



Typography

Grids and Layout

Our design grids should guide the placement and composition of text, images and graphic elements in our communications. For maximum flexibility, we have three structures for layouts, including two-column, four-column and six-column grids. Margins should generally be uniform on all sides.

However, in the spirit of being bold and boundless, an image and/or message can extend beyond the grid for greater impact (see the first example on the left below).

The following examples show how the design grid comes to life with a variety of elements, including our logo, bold messages and photography.



Color Palette

Our color palette helps express Syracuse University's distinct personality and pride.

Therefore, it's important to use only these colors to create a consistent and powerful visual identity for the University as a whole.

Orange and blue are our primary University colors, with Syracuse University Orange playing the most dominant role in our identity and community. For added flexibility and vibrancy, our secondary palette offers complementary shades of orange and blue, which can add dimension or be used as accents. All of our primary colors are suitable for headlines, subheadlines and other large, display-sized copy.

Our primary blue and dark gray are both acceptable for body copy. For web accessibility compliance, the default color for hyperlinks should be dark orange. For normal web text sizes (see page 24) or other screen-based applications—dark orange, primary blue or dark gray should be used.

All color values have been updated to optimize how they appear in—and ensure consistency across—various environments.

Primary Colors

Syracuse University Orange C:0 M:62 Y:95 K:0 R:247 G:105 B:0 #FF7690 PMS 158C	White C:0 M:0 Y:0 K:0 R:255 G:255 B:255 #FFFFFF	Primary Blue C:100 M:85 Y:5 K:36 R:0 G:14 B:84 #000E54 PMS 281C
--	---	--

Secondary Colors

Medium Orange C:0 M:84 Y:98 K:0 R:255 G:67 B:27 #FF431B PMS 2028C	Light Orange C:0 M:32 Y:100 K:0 R:255 G:142 B:0 #FF8E00 PMS 130C	Medium Blue C:90 M:68 Y:0 K:0 R:32 G:50 B:153 #203299 PMS 2728C	Light Blue C:60 M:9 Y:0 K:0 R:43 G:114 B:215 #2B72D7 PMS 2915C
Black C:0 M:0 Y:0 K:100 R:0 G:0 B:0 #000000	Medium Gray C:30 M:22 Y:17 K:57 R:112 G:119 B:128 #707780 PMS Cool Gray 9 C	Light Gray C:8 M:2 Y:0 K:30 R:173 G:179 B:184 #ADB3B8 PMS Cool Gray 7 C	

Special Use Colors

Dark Gray C:0 M:0 Y:0 K:90 R:64 G:64 B:64 #404040	Dark Orange C:10 M:88 Y:100 K:2 R:215 G:65 B:0 #D74100 PMS 1665C
---	---

Color Palette

Color Accessibility

At Syracuse University, we have and always will be actively shaping an education and environment that's innovative, impactful and inclusive.

When designing and developing our expressions and experiences, we consider the distinct perspectives and needs of all.

This page includes approved color combinations that meet our accessibility standards (WCAG 2.0 AA). When choosing typography and background colors, always promote visibility and legibility by ensuring sufficient contrast. Font sizes and weights also play a crucial role, which is why we've provided minimums for each color combination.

For more information on how to apply our typography, please see page 19.

Primary Colors—Large web text sizing

(WCAG 2.0 AA defines large web text as 18.66px or larger and bold weight, or 24px or larger.)



Text: #F76900 Background: #FFFFFF



Text: #FFFFFF Background: #F76900

Color Palette

Color Accessibility

Primary Colors—Normal web text sizing

(WCAG 2.0 AA defines normal web text as 18.66px or smaller.)



Text: #000E54 Background: #FFFFFF



Text: #000E54 Background: #F76900



Text: #000E54 Background: #FF8E00



Text: #FF431B Background: #000E54



Text: #FFFFFF Background: #000E54



Text: #F76900 Background: #000E54



Text: #FF8E00 Background: #000E54



Text: #FFFFFF Background: #2B72D7



Text: #000E54 Background: #FF431B



Text: #FFFFFF Background: #203299

Supergraphics

Block S

Our Block S can be used as a heroic graphic element (i.e., supergraphic) in one of two situations: to celebrate our dynamism, leadership and community, or to guide audiences to take action.

When applied as a supergraphic, the Block S may be cropped against the edge of the page, exemplifying how Syracuse University is on the front lines of discovery and how we embolden leaders to get to the future first.

This element is most effective in promotional materials or digital media where animation may appear.

Cropping

Cropping the supergraphic is permissible to demonstrate how our ideas, individuals and impact “go beyond.” However, to ensure that the Block S is clearly recognizable, limit cropping to two sides.

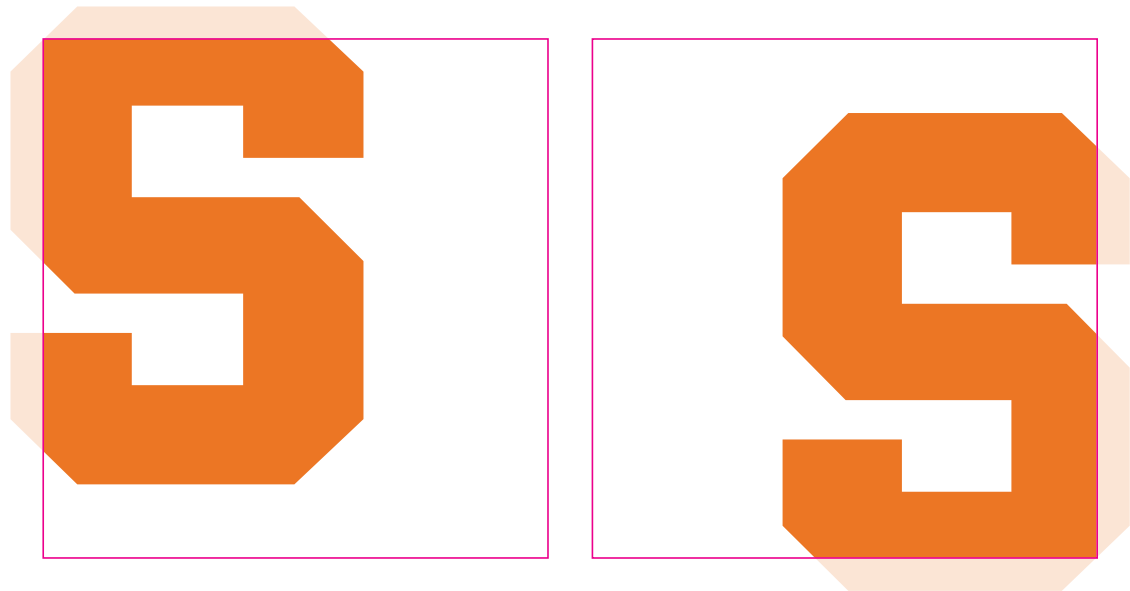

Supergraphics

Block S

Color Options

Depending on the background and surrounding elements, the Block S supergraphic can appear in Syracuse University Orange, our primary blue or knocked out (white). The knockout version can be solid or a shade of transparency. However, to avoid confusion with peer institutions, the knockout version of the Block S must always appear in close proximity to our wordmark.

Backgrounds

The Block S supergraphic can appear on white or primary color backgrounds. When applied on a Syracuse University Orange or primary blue background, the Block S can appear in the other primary color (e.g., Syracuse University Orange supergraphic against primary blue; primary blue supergraphic against Syracuse University Orange) or an approved secondary shade (e.g., medium orange supergraphic against Syracuse University Orange; medium blue supergraphic against primary blue).



Syracuse University Orange on White

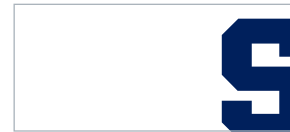

Primary Blue on White



Light Gray on White



Medium Orange on Syracuse University Orange



Primary Blue on Syracuse University Orange



Knocked out (white) on Syracuse University Orange



Syracuse University Orange on Primary Blue



Medium Blue on Primary Blue



White (50% opacity) on Primary Blue



Syracuse University Orange on Medium Orange



Primary Blue on Medium Orange



White (50% opacity) on Medium Orange

Supergraphics

Laurel

When communications need to convey our prowess and prestige, and could benefit from a textural element, the laurel from our seal may be used as a supergraphic.

For these purposes, the laurel from our seal has been redrawn to conform with modern reproduction methods (e.g., screen, engraving, offset printing, embossing, letterpress). To maintain consistency, always use the approved artwork and do not attempt to alter or recreate the laurel.

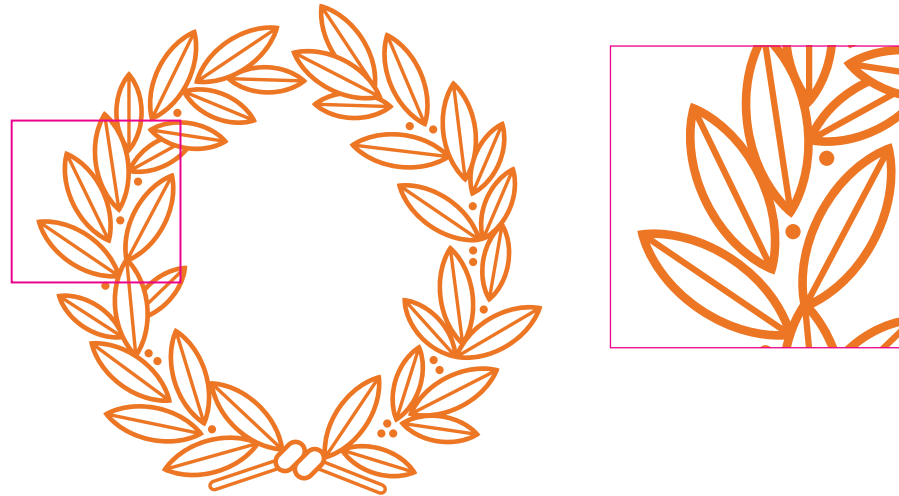

Cropping

To keep the laurel recognizable, the supergraphic should show at least two full leaves when cropped in either horizontal or vertical positions.

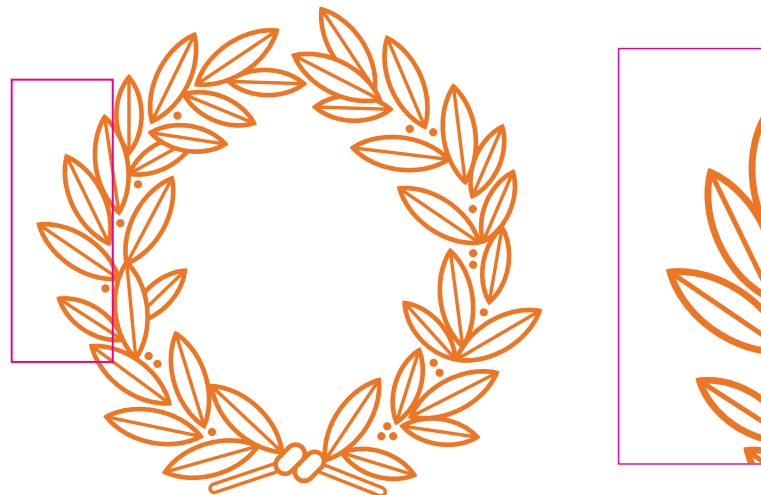

Supergraphics

Laurel

Color Options

Depending on the background and surrounding elements, the laurel supergraphic can appear in Syracuse University Orange, our primary blue or knocked out (white). The knockout version can be solid or a shade of transparency.

Backgrounds

The laurel supergraphic can appear on white or primary color backgrounds. When applied on a Syracuse University Orange or blue background, the laurel can appear in the other primary color (e.g., Syracuse University Orange supergraphic against primary blue; blue supergraphic against Syracuse University Orange) or an approved secondary shade (e.g., medium orange supergraphic against Syracuse University Orange; medium blue supergraphic against primary blue).



Syracuse University Orange on White



Primary Blue on White



Light Gray on White



Medium Orange on Syracuse University Orange



Primary Blue on Syracuse University Orange



Knocked out (white) on Syracuse University Orange



Syracuse University Orange on Primary Blue



Medium Blue on Primary Blue



White (50% opacity) on Primary Blue



Syracuse University Orange on Medium Orange



Primary Blue on Medium Orange



White (50% opacity) on Medium Orange



IMAGERY

Overview

The following pages convey how to apply our brand essence to iconography, data visualization, illustrations, photography and social media to create a cohesive style and present information in clear and compelling ways.

Iconography Styles

While imagery is primarily used to paint a picture or tell a story, icons can enhance navigation and comprehension by quickly drawing attention to important messages or actions audiences should take. Icons help people find their way, both on campus and online. At busy events like commencement or game days, icons can direct people to their seats or to the concession stands. On our website, icons can show users where to comment or find out more information.

Inspired by the angles of our Block S, our iconography style is distinct, while the subjects are intuitive and universal. Icons can be especially useful in communities where multiple languages are spoken and written. As such, they should be rendered simply and applied with intention; not as decoration or without a clear role.

For greater utility and versatility, we have two iconography treatments: outlined and filled. When applying icons, use consistent treatments within the same layout (i.e., do not mix outlined and filled icons). Syracuse University Orange should be the default color for iconography, although our primary blue or white are acceptable alternatives when using a colored background.

Icons are developed and created by the Division of Marketing and Communications. Please contact brand@syr.edu to discuss your icon needs.

Outlined Icons



Filled Icons



Iconography Styles

Design

Icons use a structural grid of 32x32 pixels (px). Outlined icons use a stroke weight equal to 1px. Corners (90° angles), where appropriate, are altered to incorporate 45° angles. Filled icons use a fill color from our color palette.

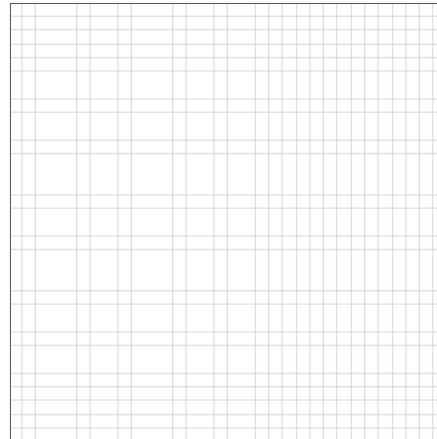

32x32px grid

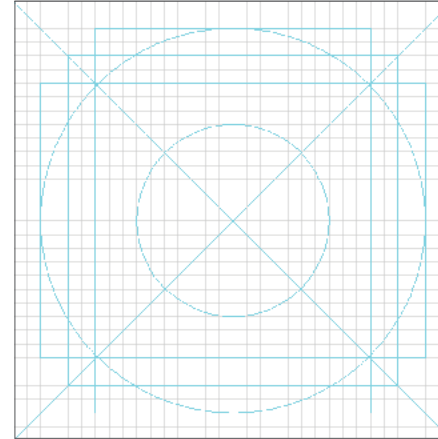

Custom keyline grid

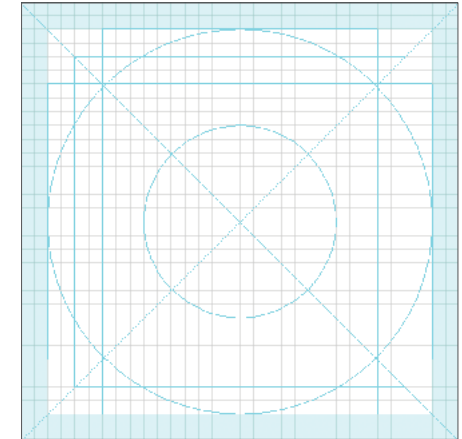

2px padding

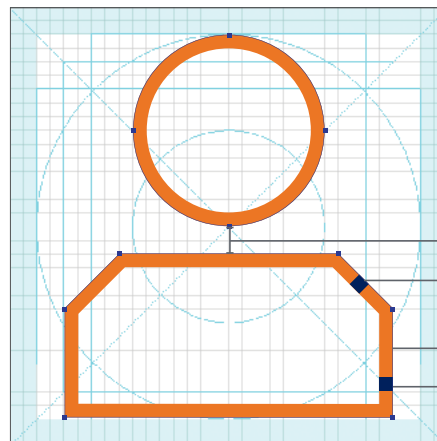

Outlined

- 2px gap
- 45° diagonal line
- Inside stroke
- 1px stroke

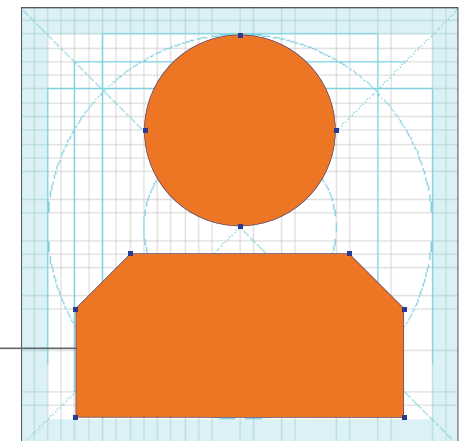

Filled

Inside stroke

Iconography Styles

Categories

Communicative



Relational



Wayfinding



Data Visualization

Syracuse University creates and connects a powerful community of game changers that move ideas, individuals and society forward.

Establishing a cohesive style to visualize data helps us clarify and amplify our distinct story of impact.

The following examples demonstrate how to apply our primary and secondary colors to highlight numbers and data in clean, clear and compelling ways.

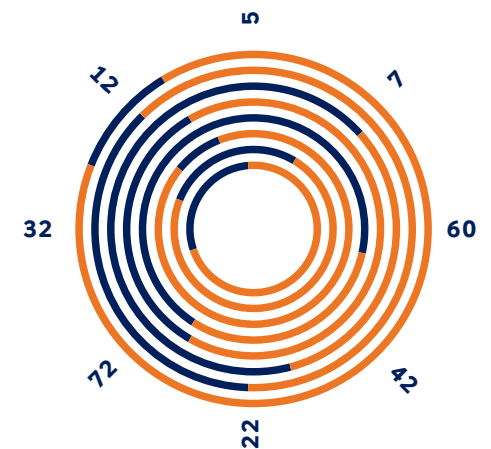
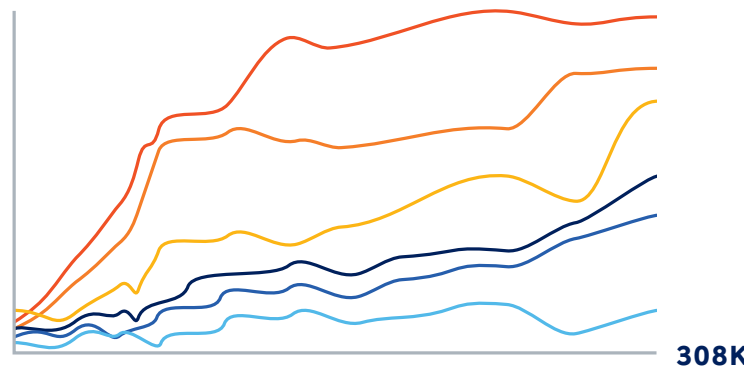
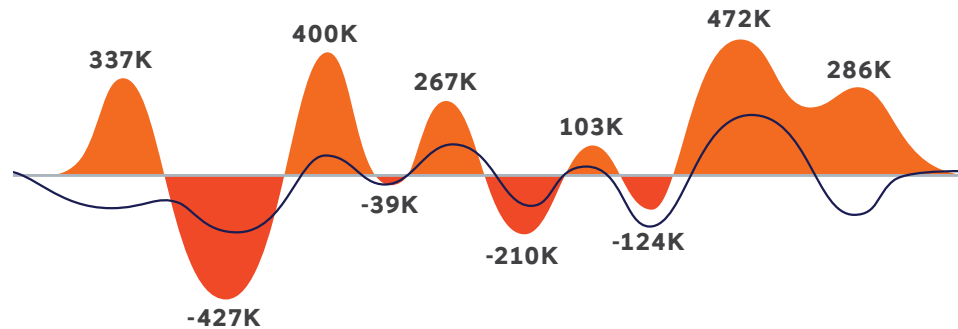
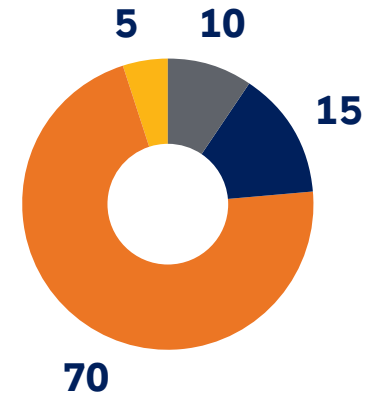

Illustration Styles

Illustrations can be a powerful storytelling device, adding greater flexibility to our visual language beyond photography. Our illustrations can be used to tell our story of impact in a variety of ways—from simple “day-in-the-life” depictions for prospective students to sophisticated portrayals of our campus, culture and community.

Like our iconography, we’ve established a consistent illustration style with multiple treatments for greater flexibility. The following sets the foundation for our illustration style with examples of our three treatments: full color, duotone and 1-color. The subsequent pages demonstrate how to adapt and apply illustrations for various purposes.



Full Color
(detailed)



Duotone

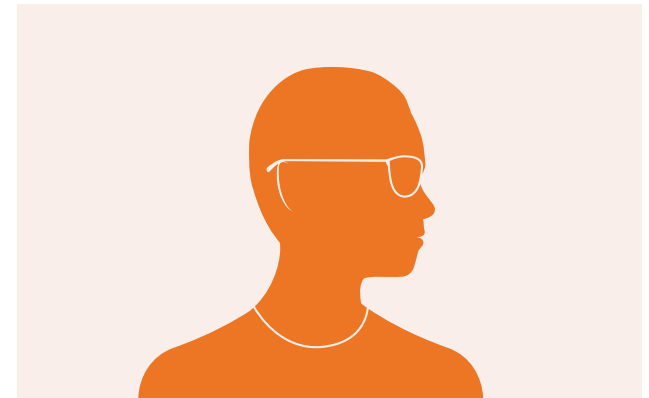

1-Color
(simplified)

Illustration Styles

Full Color

Our full color treatment is bold and dynamic. While any colors in our primary or secondary palettes can be utilized, always be mindful of our color balance to ensure appropriate use of orange.

Campus imagery can range from architectural (e.g., buildings) to abstract (e.g., aerial views).

Illustrations of people can vary in perspective and number to serve a variety of purposes. Portraits should capture the confidence of the subject and the boldness and boundlessness of our culture. For example, portraits can accompany testimonials of breakout leaders making breakthrough discoveries. Groups should feel energetic and connected, demonstrating our spirit and how we bring together diverse individuals, interests and ideas beyond disciplines.



Illustration Styles

Duotone

Our duotone treatment is simpler and more restrained than our full color illustrations. This option can be applied on communications where full color may be too busy or distracting.

Syracuse University Orange is our preferred duotone color. While no more than two shades per illustration is ideal, multiple transparencies of each color can add dimension and depth to illustrations. To promote visibility and create the right effect, always ensure sufficient contrast between tones.



1-Color

Our 1-color treatment is a simple way to represent someone or something as a dark shape or outline against a light background. Like our duotone treatment, use our 1-color illustrations when striving for simplicity. Unlike the duotone option, 1-color illustrations should have limited details and a solid, shadow-like feel.

Syracuse University Orange is our preferred color for this treatment. To promote visibility and create the right effect, always ensure sufficient contrast between the subject and background.

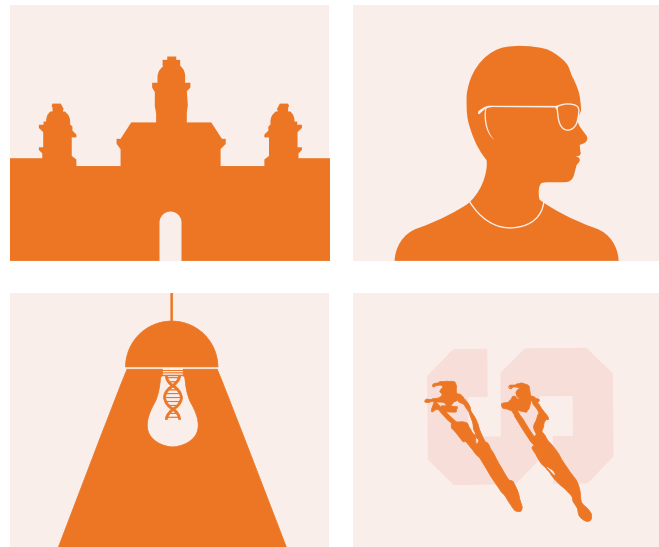

Illustration Styles

Architectural

Architectural illustrations are an effective way to highlight locations on our vibrant campus. In addition to Universitywide communications, these illustrations can be applied by schools, colleges and/or departments with strong associations to specific buildings.

When communicating with working professionals and lifelong learners who engage with Syracuse University through flexible formats, avoid using place-based illustrations, as they may not experience these firsthand.



Crouse College



Hall of Languages

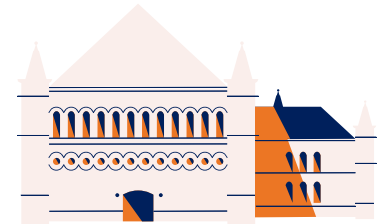

Tolley Hall



Hendricks Chapel

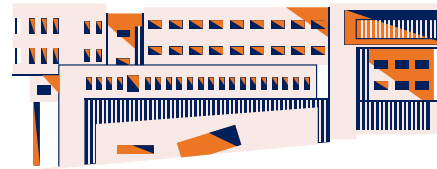

Dineen Hall

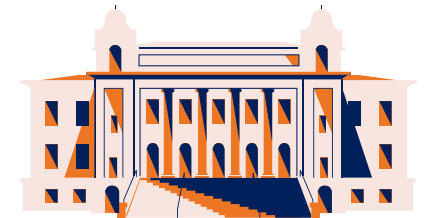

Carnegie Library

Photography

Our Pillars

Our brand strategy informs our approach to photography (see page 7 for more information our strategy, including our pillars and personality). Our photography should reflect our voice by portraying diverse individuals or groups in ways that feel bold, boundless, welcoming and transformational.

*Unless unavoidable, stock photography should not be used in our materials.

Purposeful Education

Participatory Approach

Proud Community

Powerful Network

Individual



Group



Abstract



Photography

Our Style

To create photographs that authentically reflect our institution, use a style that is active, inviting and unexpected.



Active

Consider candid images that tell a story by featuring people engaged in authentic activities that are relevant and resonant for our key audiences.

What to look for:

- Small depth of field
- Natural light
- Not staged



Inviting

Choose photographs that draw people in and make them want to learn more. Avoid using images that feel too composed or contrived.

What to look for:

- Light background
- Uncluttered background
- Soft focus depth of field



Unexpected

Thoughtful cropping and dynamic perspectives are also recommended to energize our imagery.

What to look for:

- Angle composition
- Natural shadows
- Neutral color background

Photography

Other Creative Considerations

Event Photography

Make sure that you have a variety of images from each event to include:

1. Scene setters/room shot (e.g., empty and full)
2. Details (e.g., signage, graphics, food, awards, architecture)
3. Important people, VIPs
4. Candid/formals
 - Include various angles, compositions and a mix of wide and telephoto captures.
 - Focus on the energy and emotion of the event.
 - Be stealthy during speeches and action, yet commanding during formal group shots.

Group Portraits

1. For groups of 10 or more, arrange as staggered by height or on stairs. Use the shape of a triangle as a guide for placement.
2. Prioritize placing prominent members (e.g., award recipients or speakers) toward the center of the image. Arrange other subjects based on relationship, height, then outfit color coordination.
3. Look for a neutral background or the least cluttered area when possible.

Classroom Photography

1. Focus on students as the main subjects.
2. Show student and faculty interaction.
3. Include a broad range of compositional elements with groups.
4. Capture students working directly with technology or relevant course material.

Videography

Our Pillars

Our brand strategy informs our approach to videography (see page 7 for more information on our strategy, including our pillars and personality). Our videography should reflect our voice by portraying diverse individuals or groups in ways that feel bold, boundless, welcoming and transformational.

*Unless unavoidable, stock video should not be used in our materials.

Purposeful Education

Participatory Approach

Proud Community

Powerful Network

Individual



Group



Abstract

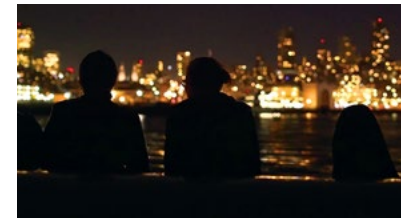

Videography

Our Brand Story

**Our four pillars guide our creative thinking.
Use them as a lens to help tell our story.**



Purposeful Education

Our students work together with leading faculty and international scholars who contribute to breakthrough discoveries and ideas. When preparing to film in various unique academic settings, think about the message each shot can communicate. Our storytelling should reflect our institution authentically. As a student-centric research University, our students should be at the center of our storytelling. Show their opportunities for collaboration and hands-on learning, as well as shared engagement from our faculty.

Key shots:

- Student interest and involvement
- Hands-on involvement in learning
- Faculty-student collaboration
- Authentic visuals of the student experience in the academic setting



Participatory Approach

Our students are continuously finding new ways to participate across campus and beyond the University community. Capturing these moments can be an exceedingly positive part of our multimedia content. Showcasing the developing passions of these students helps to highlight Syracuse as a welcoming community that allows our students to pursue any path they choose.

Key shots:

- Participation of students and faculty
- Collaboration and involvement in community
- Students creating their own paths
- Students outside of the typical academic settings



Proud Community

We expect our students to discover new passions, cultivate different strengths and challenge conventional wisdom. Our inclusive education and renewed focus on holistic student wellness has raised the bar on what we want to epitomize as a university, not to mention the unsurpassed support of our 18 Division 1 athletic teams. There are many ways to illustrate to our viewers how deep our pride runs throughout generations of Syracuse Orange.

Key shots:

- Welcoming and inviting
- Students making lifelong friendships/relationships
- Passionate students and fans
- Life-changing learning



Powerful Network

A powerful network of Syracuse University alumni plays a significant role in the future success of our students. Our alumni's valuable influence is demonstrated through **opening up doors** to internship opportunities, immersion experiences, and the sharing of real-life, authentic insights.

Key shots:

- Student-alumni interactions
- Students experiencing future career options
- Students all over the world/country

Videography

Our Style

Our philosophy is to craft intentional cinematic images that elevate the stories of Syracuse University in authentic, informative and emotional ways.

While it is our goal to capture student experiences in the most authentic way possible, intentionality is the key to impactful visuals. We must be thoughtful and focused with planned camera movement, lighting, color palette and artistic direction to create dynamic images that serve a purpose.

In general, there are three main categories for our videos—*informational*, *emotional* and *event coverage*. These styles often overlap, but it can be helpful to break them down in terms of approach.

Styles of Videography:

Informational

These videos share interesting stories about students, faculty, and/or Syracuse University in general.



Emotional

These videos influence the viewer to feel a specific way and motivate them to take some course of action.



Event Coverage

These videos record events that will be shared at a later time or that will be archived.



Videography

Other Creative Considerations

Informational

Interviews:

- When possible, interviews should be conducted in the subject's natural space. These spaces (office, classroom, home) can often provide extra visual information to the audience about the subject's role and personality.
- In general, subjects should look off camera and be framed with plenty of negative look space. This gives the subject a sense of authority and knowledge.
- Lighting should look natural, but add depth to the scene by using shadow and contrast.

B-Roll:

- Footage should be a combination of events captured in real time and staged shots when necessary.
- Subjects should not be asked to do tasks that don't make sense for the action being recorded.
- When possible, pay attention to background and color palette. Minimal artistic direction should be utilized to introduce primary and secondary color.
- Artistic direction should not look staged or "over the top."
- Natural light should be controlled and supplemented with artificial light to create depth and interest in the image.

Emotional

Interviews:

- For emotional videos, interview locations should be more controlled than in informative videos. Give thought to how the location affects the feeling of the interview.
- In general, subjects should look into the camera and be centered, framed with plenty of depth behind them to separate them from the background. This gives the audience an emotional connection to the interview subject.
- Lighting can be more dynamic, using shadows or color to heighten emotion. Lighting should add depth to the scene by using shadow and contrast.

B-Roll:

- Footage should be more pre-planned, with the goal of capturing authentic moments.
- Subjects can be given more direction in terms of wardrobe and actions.
- When possible, pay attention to background and color palette. Artistic direction should be utilized to introduce primary and secondary color.
- Artistic direction should alter the set to complement the emotion of the scene but not be distracting or change the "authenticity" of the scene.
- Natural light should be controlled and supplemented with artificial light to create depth and interest in the image.
- Camera movements and transitions, when possible, should be planned and discussed prior to the shoot.

Event Coverage

Interviews:

- Usually, interviews aren't necessary for these types of videos. However, when interviews are needed, they should be conducted at the event with minimal set-up and disruption.
- In general, subjects should look off camera and be framed with plenty of negative look space. This gives the subject a sense of authority and knowledge.
- Lighting should look natural.

Social Media

For our flagship social media accounts (e.g., SyracuseU), where space is limited, use our standard Block S to represent Syracuse University.

Always ensure that our full name is included nearby (e.g., “Syracuse University” in text in the profile copy or a wordmark in the cover image).





DESIGN INSPIRATION

Overview

The applications on the following pages demonstrate how our visual identity comes to life across a spectrum of communications, formats and channels.

These examples are for illustrative purposes only.

Inspiration

Expressions Dial

Our visual identity toolkit can be flexed to meet a variety of objectives, audiences and settings. Just as you'd change your tone between a formal presentation and conversation with your best friend, always be mindful of who we're targeting and what we want them to think, feel and/or do.

Depending on your objective, use the guide to the right to determine when our communications should be visually simplified, amplified or somewhere in between.

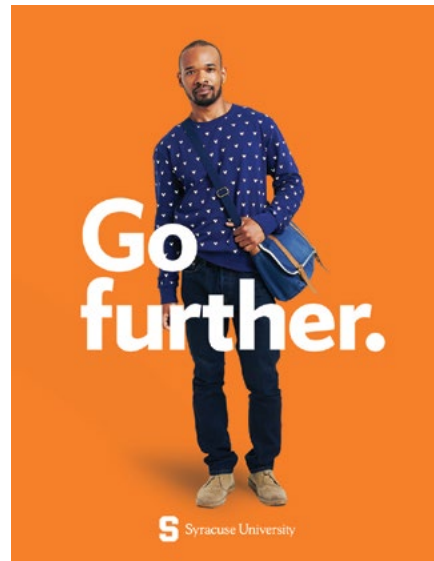
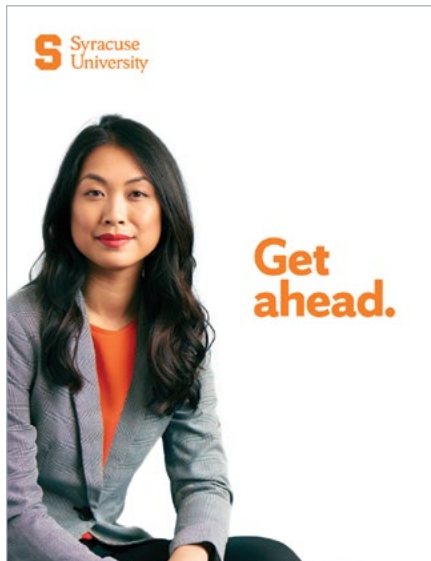

Simplified

Amplified

Inspiration

Posters



Inspiration Magazine



Inspiration Guide



Inspiration

Merchandise



Inspiration

Digital

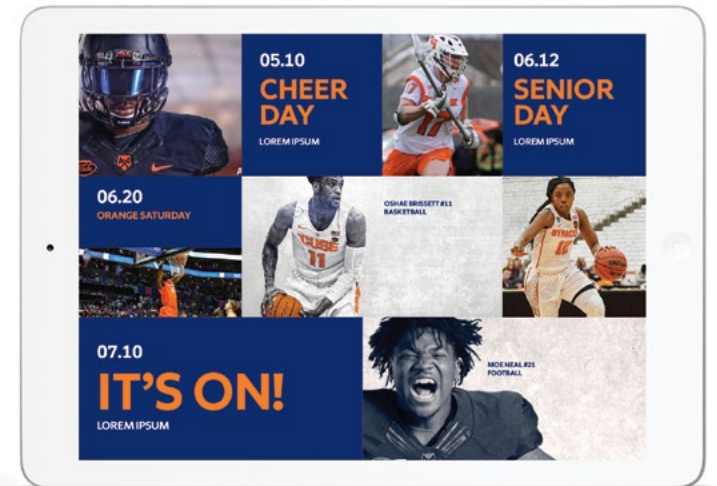
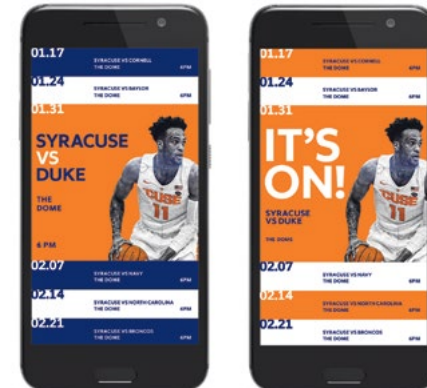
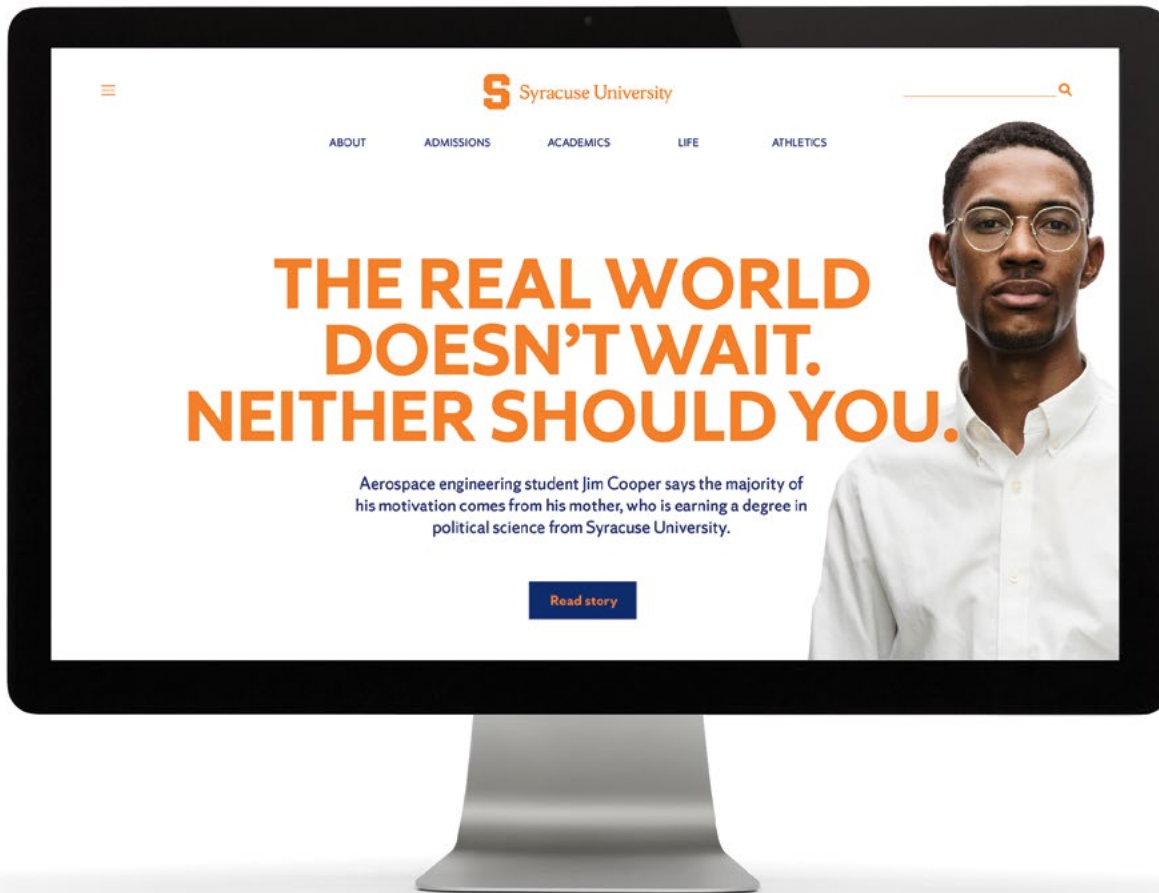

Inspiration

Environmental



Inspiration

Environmental



For questions related to these guidelines, please contact brand@syr.edu.

