

SYSTEM SAVER 318 AIR COMPRESSOR FOR MACK E-TECH™ AND ASET™ ENGINES

MAINTENANCE MANUAL

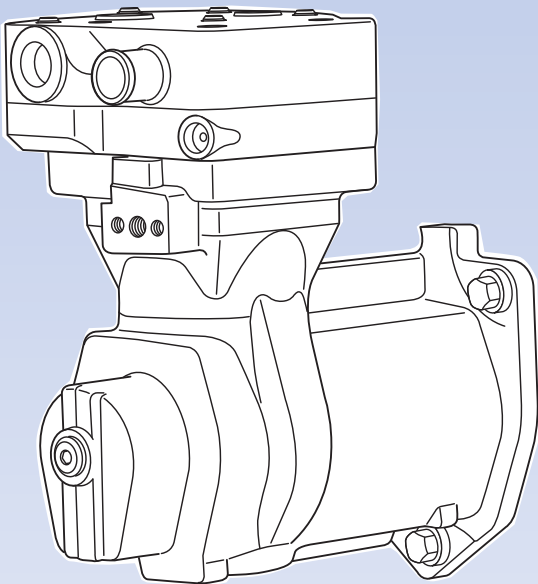

NON-THROUGH DRIVE

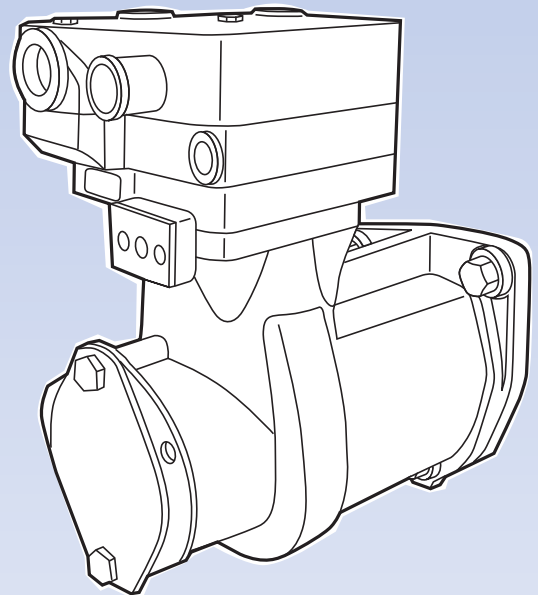

THROUGH DRIVE

Service Notes

About This Manual

This manual provides service and repair procedures for the WABCO System Saver 318 air compressor.

Before You Begin

1. Read and understand all instructions and procedures before you begin to service components.
2. Read and observe all Warning and Caution hazard alert messages in this publication. They provide information that can help prevent serious personal injury, damage to components, or both.
3. Follow your company's maintenance and service, installation, and diagnostics guidelines.
4. Use special tools when required to help avoid serious personal injury and damage to components.

Hazard Alert Messages and Torque Symbols

WARNING

A Warning alerts you to an instruction or procedure that you must follow exactly to avoid serious personal injury and damage to components.

CAUTION

A Caution alerts you to an instruction or procedure that you must follow exactly to avoid damage to components.

 This symbol alerts you to tighten fasteners to a specified torque value.

How to Obtain Additional Maintenance and Service Information

Visit Literature on Demand at meritor.com. WABCO publications are also available on our website: wabco-na.com.

WABCO Customer Care

Call WABCO North America Customer Care at 855-228-3203.

How to Obtain Tools and Supplies Specified in This Manual

Call Meritor's Commercial Vehicle Aftermarket at 888-725-9355 to obtain tools and supplies.

Information contained in this publication was in effect at the time the publication was approved for printing and is subject to change without notice or liability. WABCO reserves the right to revise the information presented or to discontinue the production of parts described at any time.

pg. 1	Section 1: Introduction
	Application
	Description
2	Operation
	Maintenance Intervals
	Cylinder Head
3	Visual Inspection
4	Section 2: Troubleshooting
7	Section 3: Compressor Replacement
	Compressor
	Replacement Information
	Removal
8	Installation
	Cylinder Head
	Removal
9	Installation
10	Testing
	Air System Leakage Test

Notes

Application

- System Saver 318 non-through drive version air compressor used on Mack engines. Figure 1.1.
- System Saver 318 through-drive version air compressor used on Mack engines. This unit is required to run hydraulic power steering pumps. Figure 1.1.
- Swept volume displacement: 18.7 cubic feet per minute.
- Flange mounted to the engine.
 - Coupling driven.
 - Inlet air, oil lubrication and coolant supplied from the engine.
- Pneumatic pressure signal from the governor controls compression:
 - Integrated pressure relief valve protects the compressor and engine if discharge or governor lines become blocked, or if compressor cannot unload. The valve prevents the compressor from pumping above 250 psi in the event of a blocked discharge line or other malfunction.

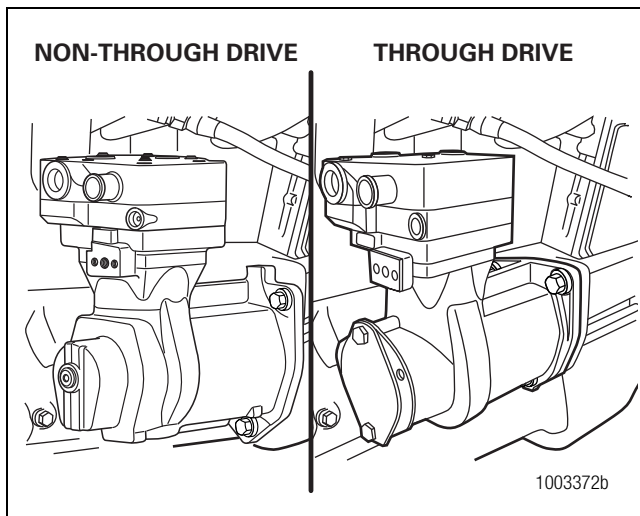

Figure 1.1

Description

The WABCO System Saver 318 air compressor provides and maintains air under pressure to operate devices in the air brake and auxiliary air systems of a vehicle. It consists of two major subassemblies: Cylinder head and crankcase/cylinder block. Figure 1.2.

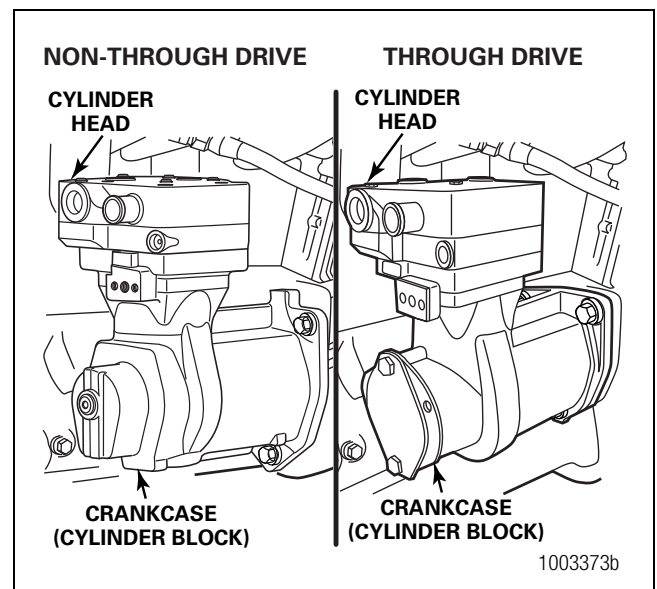

Figure 1.2

The **cylinder head** contains the inlet, discharge and unloader valving, as well as an integral relief valve. There are two water ports, marked Port 9, an air discharge port, marked Port 2, and an inlet port, marked Port 0. The cylinder head is mounted on the crankcase/cylinder block.

The **crankcase/cylinder block** contains the cylinder bore, piston, bearings, crankshaft, governor port and connecting rod.

1 Introduction

Operation

The compressor is driven by the engine and its crankshaft turns continuously while the engine is running. Compression of air is controlled by the **governor** and by the **compressor's unloading mechanism**.

The **governor** maintains the brake system air pressure at preset maximum and minimum levels. The governor is mounted apart from the compressor, either horizontally or vertically. The governor port is located on the crankcase of the compressor. Figure 1.3.

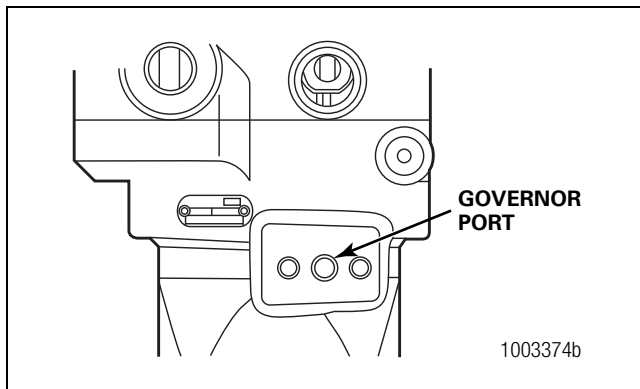

Figure 1.3

The **unloader mechanism** controls the air compression cycle; an air compression cycle has three phases:

1. **Induction:** Air flows from the engine to the compressor, opening an inlet valve in the cylinder head of the compressor.
2. **Compression:** Air pressure is increased, causing the compressor's discharge valve to open.
3. **Unloading:** Air passes from the cylinder to the inlet chamber of the cylinder head via a port controlled by a sliding leaf valve.

When system cut-in pressure is reached, air is exhausted from the unloader port.

4. After unloading, the unloader piston returns the sliding leaf valve to the loaded position. This seals the unloader ports and compression resumes. Figure 1.4.

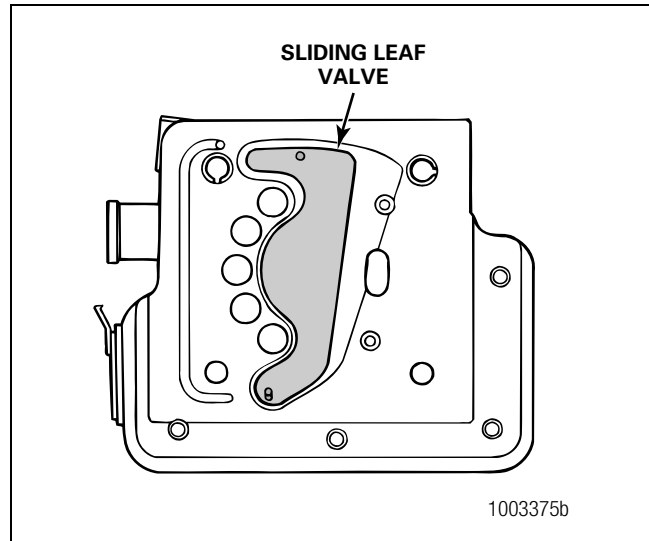

Figure 1.4

Maintenance Intervals

The WABCO System Saver 318 air compressor receives inlet air, oil and coolant from the engine, so it is important to follow the engine manufacturer's recommendations and maintenance schedules regarding fluid levels, air filter and recommended change intervals.

Cylinder Head

Remove carbon deposits from the discharge cavity and rust and scale from the cooling passages of the cylinder head.

Clean carbon and dirt from the inlet and unloader passages.

NOTE: Shop air may be used to blow the carbon and dirt deposits from the unloader passages.

Visual Inspection

A visual check of the compressor can detect minor problems. This check should be part of the vehicle preventive maintenance program. Figure 1.5.

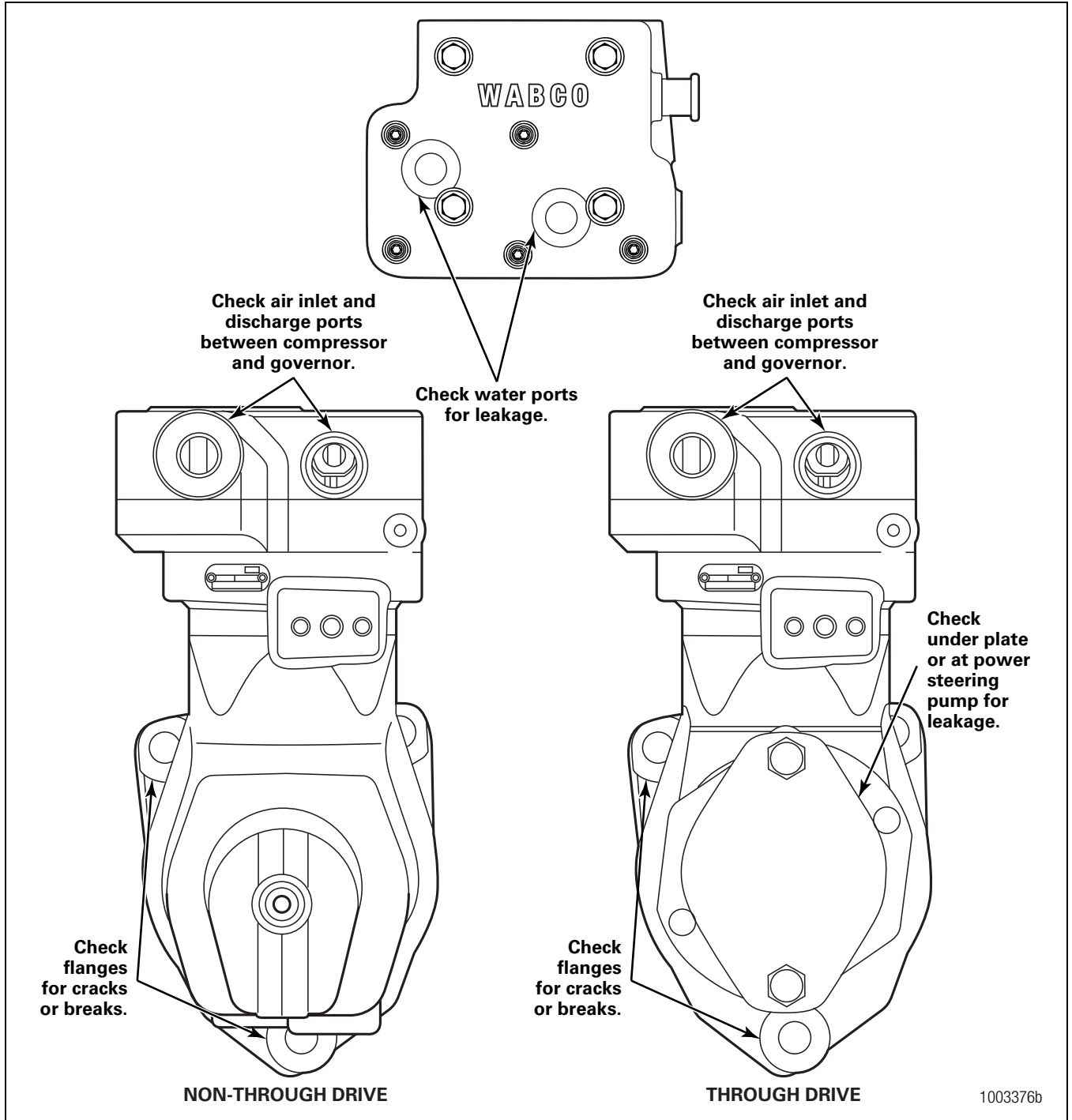

Figure 1.5

2 Troubleshooting

Hazard Alert Messages

Read and observe all Warning and Caution hazard alert messages in this publication. They provide information that can help prevent serious personal injury, damage to components, or both.

WARNING

To prevent serious eye injury, always wear safe eye protection when you perform vehicle maintenance or service.

Use Table A to troubleshoot the WABCO System Saver 318 air compressor.

NOTE: If you have any questions or need additional information, please contact WABCO North America Customer Care at 855-228-3203.

Table A: Compressor Troubleshooting Guide

Condition	Possible Cause	Solution
Compressor passes excessive oil (for example, the presence of oil at exhaust air brake system valves, oil in air dryer desiccant, etc.)	Blocked or restricted oil return	Clean oil drain passages in the compressor and on the engine surface. Verify correct passage alignment.
	Contaminated inlet air or oil	Replace damaged, defective or dirty engine air filter. Repair any leaking, damaged or defective compressor air intake components. Change engine lubricating oil. NOTE: To avoid this condition, make sure vehicle manufacturer's oil and filter maintenance schedules are followed.
	Restricted air inlet or excessive vacuum present at compressor inlet	Verify engine or compressor air cleaner is functioning correctly. Replace if necessary. Repair compressor air inlet kinks or excessive bends. Check vehicle specifications to ensure air and coolant lines meet all requirements.
	Excessive engine crankcase pressure	Verify engine crankcase venting is to manufacturer's specification.
	Compressor duty cycle too high	Check system for leaks. Make necessary repairs.
	None of the above, but condition persists	Replace the compressor.
Compressor leaks oil	Physical damage or internal problems with compressor	Replace the compressor.
Compressor continuously cycles	Compressor unloader piston leaking	With compressor unloaded, check for air leakage. If leaking, replace the cylinder head.
	Governor air leak	Refer to the manufacturer's manual for governor maintenance and troubleshooting procedures.
	Dryer purge valve air leakage	Check for air dryer malfunction. Refer to air dryer manufacturer's service instructions.
	Air leak at governor-compressor attachment	Inspect connection for physical damage. Inspect and repair connection.
	Air leak at alcohol injector	Clear line of any obstructions. Inspect and repair connection.
	Excessive reservoir contamination	Drain reservoirs.
	None of the above, but condition persists	Replace the compressor.

Table A: Compressor Troubleshooting Guide

Condition	Possible Cause	Solution
No air delivery Low air delivery Low air pressure	Discharge line blockage	<p>Check for freeze up in the discharge line.</p> <p>Check low spots and eliminate any traps in the discharge line.</p> <p>Inspect and repair compressor discharge port and clear any line restrictions. Replace damaged lines as necessary.</p> <p>Check for carbon build-up. If carbon has built up, make sure cooling lines are not kinked or restricted. If carbon has built up in the discharge line, replace the line.</p>
	Inlet line kinked or restricted	Inspect the compressor air induction line for kinks and restrictions. Repair or replace as necessary.
	Governor malfunction or misadjustment	<p>Check for correct loader/unloader cycles of compressor.</p> <p>Refer to vehicle manufacturer's manual for governor maintenance and troubleshooting procedures.</p>
	External contamination	Replace broken, defective or dirty air filters. Clean contaminants from surface of compressor.
	Air dryer purge valve stuck open or leaking	Check for air dryer malfunction. Refer to air dryer manufacturer's service instructions.
	Chafed or worn discharge line	Replace faulty sections of discharge line.
	Loose or leaking air line connections	<p>Verify all connections are secure.</p> <p>Tighten to vehicle specifications where necessary.</p> <p>Inspect port threads for damage. If damage is extensive, replace cylinder head.</p>
	Damage to compressor valves and/or valve seats	Replace the cylinder head.
	Leaking or malfunctioning internal pressure relief valve	Replace the cylinder head.
Noisy air compressor	Loose drive hub	Check fit of drive coupling.
	Loose accessory drive coupling	<p>Ensure hub is completely seated and crankshaft nut is tight.</p> <p>Inspect crankshaft for damage — replace compressor if crankshaft is damaged.</p>
	None of the above, but condition persists	Replace the compressor.
Broken connecting rod or crankshaft	Oil starvation to crank pin or front main bearing	Check oil pressure. Verify oil passage is free of obstructions. Make necessary repairs.
	Failed power steering pump (through-drive version only)	Verify power steering pump is in correct operating order. Refer to the component manufacturer's service instructions.
	All of the above	Replace compressor.

2 Troubleshooting

Table A: Compressor Troubleshooting Guide

Condition	Possible Cause	Solution
Compressor leaks engine coolant	Loose fitting	Check fittings at compressor and engine for leaks and verify fittings are correctly torqued.
	Cracked coolant port	Replace cylinder head.
	Porosity in cylinder head	Replace cylinder head.
	Leaking of gasket internal to the cylinder head	Verify cylinder head bolts are correctly torqued. Make necessary adjustments. Inspect gasket for cracks or signs of wear. Replace if necessary. Replace cylinder head.
	None of the above, but condition persists	Replace compressor.
Compressor pressurizes coolant system or coolant leakage to compressor inlet	Leaking of gasket internal to the cylinder head	Inspect gasket. Replace if necessary.
	Cavitation or corrosion in cylinder head	Replace cylinder head.
	Porosity in cylinder head or cylinder head cracked	Replace cylinder head.
	None of above, but condition persists	Replace the compressor.
Unloader leakage	Possible internal damage, including worn or damaged unloader piston O-ring, porosity in unloader piston bore, loose or leaking seal at unloader piston bore	Replace compressor cylinder head assembly.
Compressor head gasket failure	Discharge line blocked due to freezing or carbon build-up	Check for trap (low spots) in lines. Make necessary repairs. Clear discharge line. Replace line if necessary. Check for carbon build-up. If carbon build-up is present, replace the discharge line.
	Frozen or blocked line to governor	Clear blocked line. Replace line if necessary. Check for air dryer malfunction. Repair or replace as required. Refer to the air dryer manufacturer's maintenance manual for service information.
	Governor malfunction	Repair or replace the governor. Refer to governor manufacturer's maintenance manual for service information.
	Incorrect cylinder head bolt torque, machining defect on cylinder head or block, defective cylinder head gasket	Inspect gasket. Replace if necessary. Verify all bolts are correctly torqued. If problem persists, replace cylinder head.
	None of the above, but condition persists	Replace compressor cylinder head assembly.

Hazard Alert Messages

Read and observe all Warning and Caution hazard alert messages in this publication. They provide information that can help prevent serious personal injury, damage to components, or both.

WARNING

To prevent serious eye injury, always wear safe eye protection when you perform vehicle maintenance or service.

Remove all pressure from the air system before you disconnect any component. Pressurized air can cause serious personal injury.

Park the vehicle on a level surface. Block the wheels to prevent the vehicle from moving. Support the vehicle with safety stands. Do not work under a vehicle supported only by jacks. Jacks can slip and fall over. Serious personal injury and damage to components can result.

Compressor

Replacement Information

The cylinder head portion of the compressor is replaceable. The crankcase is not replaceable. If the crankcase is damaged or malfunctioning, replace the complete compressor.

The removal instructions given in this manual are general. Depending on the type of vehicle involved, additional steps may be required. Refer to the vehicle manufacturer's manual for additional information.

The front of the WABCO System Saver 318 air compressor is mounted to the engine.

Before you remove the compressor, make sure you have a replacement gasket to install with the new compressor, Mack part number 590GB2159. Figure 3.1.

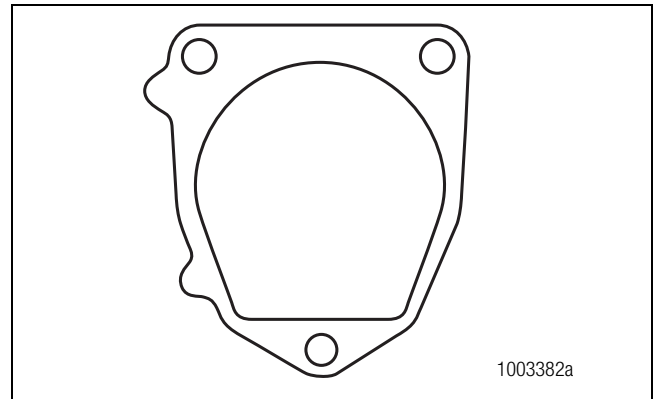

Figure 3.1

Removal

1. Park the vehicle on a level surface and set the parking brakes. Block the wheels to prevent the vehicle from moving.
2. Drain the air pressure from the air system.
3. Drain the engine cooling system and the cylinder head of the compressor.
4. Disconnect all air and water lines leading to the compressor.
5. **Through-drive version air compressor only:** If there is a power steering pump installed at the **back** of the compressor, remove the power steering pump. Figure 3.2. Disconnect the power steering pump. Refer to the manufacturer's manual for specific information. It is not necessary to remove pumps installed at the front of the compressor.

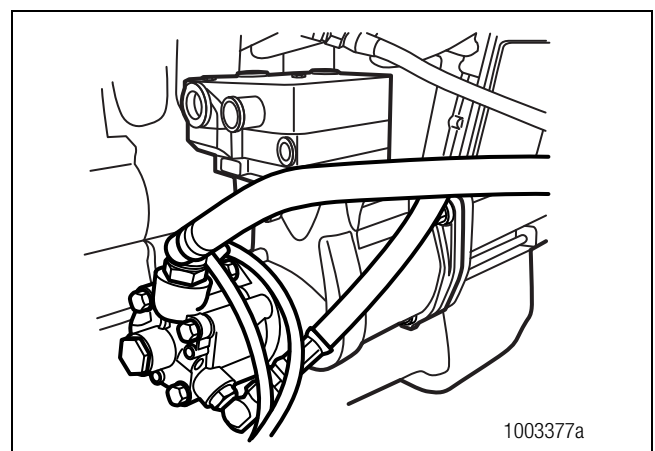

Figure 3.2

6. Remove the discharge and coolant fittings. Note fitting locations to aid in assembly.

3 Compressor Replacement

7. Loosen the three flange mounting bolts that hold the compressor to the engine.
8. Remove the compressor from the vehicle.

Remove and retain the oil supply tube that runs between the compressor and the engine. Figure 3.3.

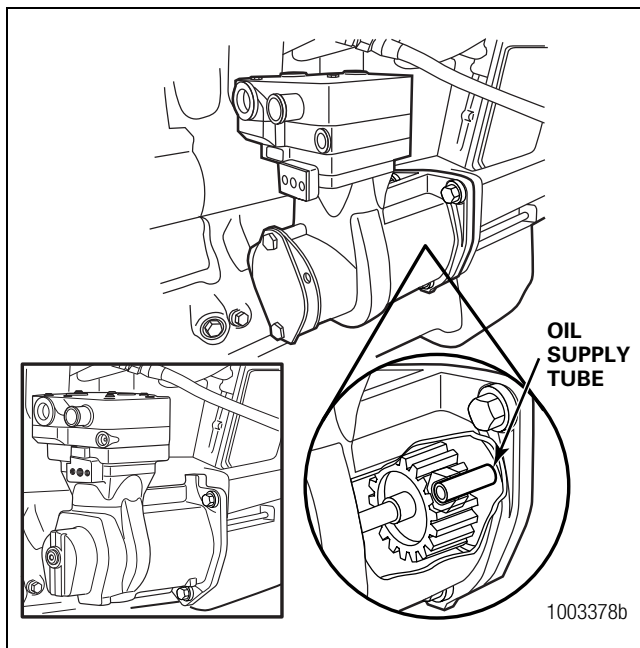



Figure 3.3

Installation

1. Reinstall the oil supply tube.
2. Install a new compressor gasket.
3. Position the compressor on the engine.
4. Install the three flange mounting bolts. Tighten to 15 lb-ft (20 N•m) +90° rotation. 
5. Attach the discharge and coolant fittings. Tighten to 22 lb-ft (30 N•m) +360° maximum to position the fitting. 
6. Connect all air and water and lines leading to the compressor. Tighten per Mack specifications.
7. **Through-drive version air compressor only:** If necessary, reinstall the power steering pump. Refer to the manufacturer's maintenance manual to verify that the installation is to the correct specifications.

8. Add engine coolant to the cooling system. Use the coolant recommended by the engine manufacturer. Visually inspect the engine and compressor for leaks.
9. Start the engine and allow the air system to build to governor cutout. Stop the engine. Use a soap-and-water solution at connection points to check for air leaks. Make any necessary repairs.
10. Remove the wheel blocks. Release the spring (parking) brakes.

Cylinder Head

Removal

1. Remove the compressor from the engine. Refer to the procedure in this section. Take care not to damage the crankcase, since it will not be replaced.
2. Use a cleaning solvent to remove road dirt and grease from the exterior of the compressor.
3. Remove the four bolts that attach the cylinder head to the crankcase and remove the cylinder head. Figure 3.4.

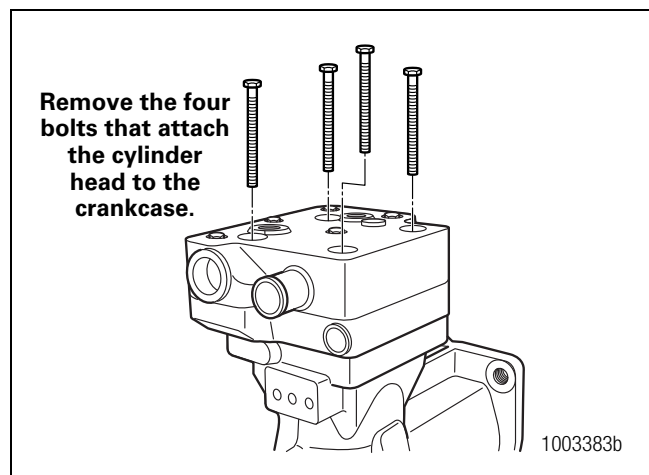

Figure 3.4

4. Use a cleaning solvent to clean the top of the crankcase.

3 Compressor Replacement

Installation

NOTE: A Torx® tool is required for this procedure.

Cylinder head valve components **MUST** be aligned in the correct position in order for the compressor to function.

1. Align the hole in the cylinder head gasket with the unloader passage on the top of the crankcase. Figure 3.5.

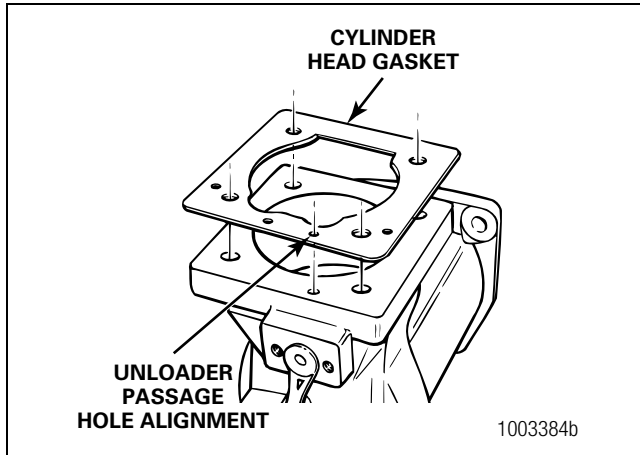

Figure 3.5

NOTE: A light application of engine oil will hold the sliding leaf to the inlet valve.

2. Install the sliding leaf. The two holes in the sliding leaf must be installed over the two pins on the base of the cylinder head. Figure 3.6.

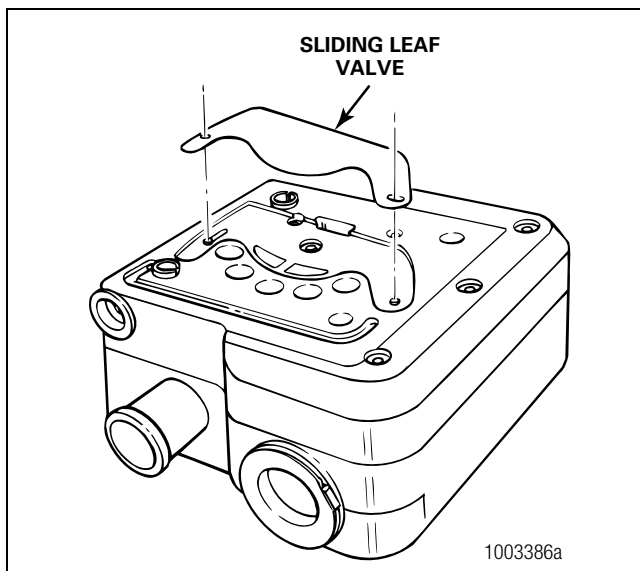

Figure 3.6

3. Position the inlet valve on the bottom of the cylinder head. Align the large holes. Figure 3.7.

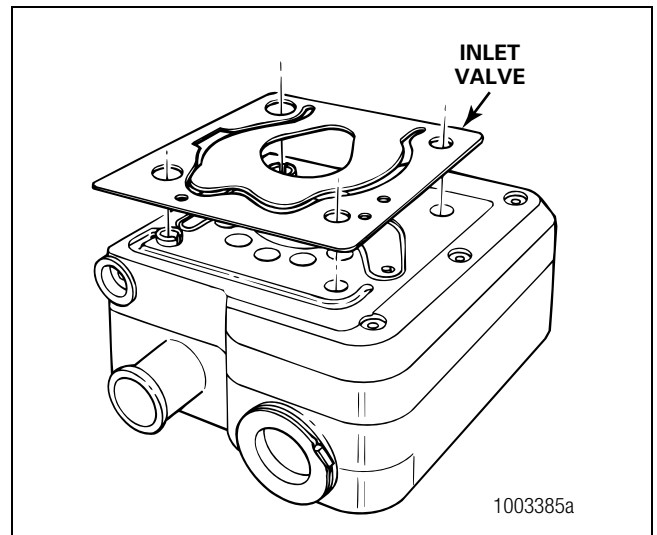

Figure 3.7

4. Position the cylinder head on top of the crankcase. Ensure the notched pins on the cylinder head align with the recesses in the block. Only two bolt holes have split alignment sleeves. Figure 3.8.

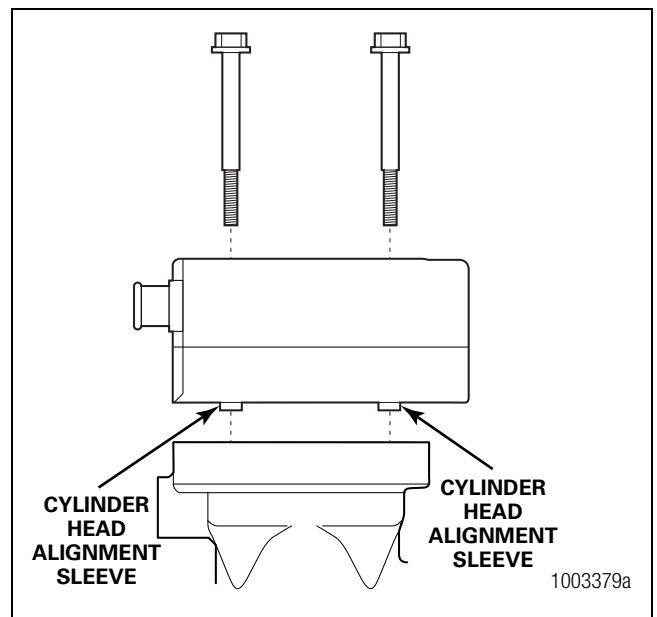



Figure 3.8

3 Compressor Replacement

5. Install the four hex-head mounting bolts that hold the cylinder head in place. Tighten the mounting bolts in sequence (1 - 2 - 3 - 4) to 18.5 to /-2.5 lb-ft (25 to /-5 N•m). Then, apply $90^\circ +15^\circ/-5^\circ$ rotation to the four cylinder head bolts. Use an angular gauge to check the rotation. Figure 3.9. 

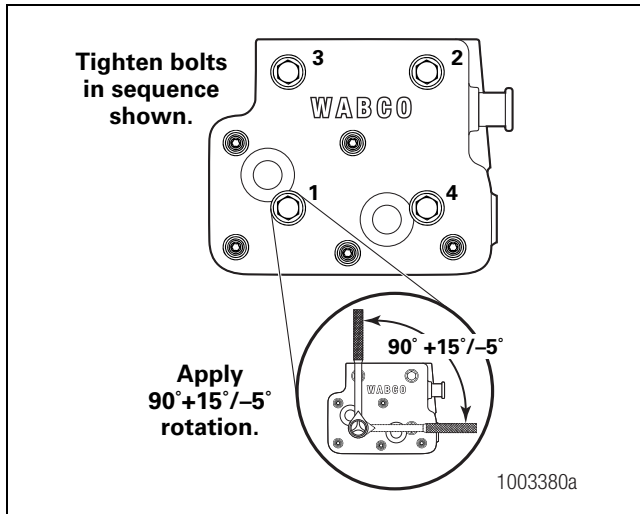



Figure 3.9

6. Use a Torx[®] tool to tighten the five Torx[®] head screws in sequence (5 - 6 - 7 - 8 - 9) to 4.4 lb-ft (6 ± 0.6 N•m). Then, apply an additional $90^\circ +15^\circ/-5^\circ$ rotation to the five Torx[®] head screws. Use an angular gauge to check the rotation. Figure 3.10. 

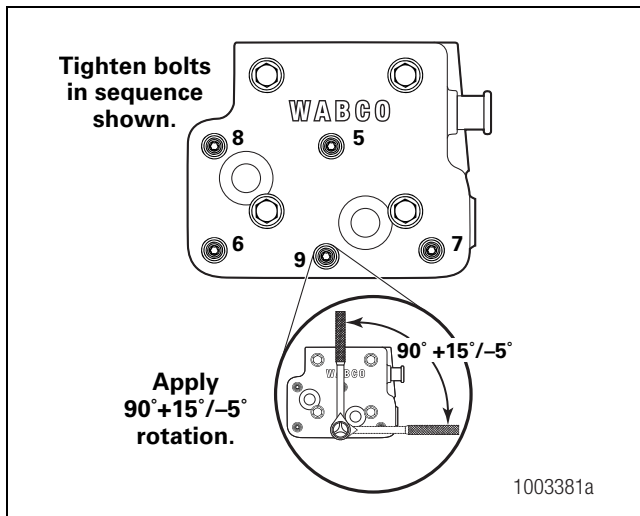

Figure 3.10

7. Install the compressor and test for leaks. Refer to the procedures in this section.

Testing

Test the vehicle air system as follows.

1. Bleed the vehicle air system reservoir gauges down to approximately 85 psig. Apply brakes several times.
2. With the engine running at full governed speed, with no load or air accessories being used, the compressor should reach governor cutout pressure, then unload.

If the compressor does not reach governor cutout pressure, check for air leaks in the system. If reservoir volume and engine RPM are per original vehicle manufacturer's specifications, system plumbing leakage must be checked and, if necessary, repaired. Refer to the air system leakage test procedure in this section.

If the compressor fails to unload, verify correct governor operation.

Air System Leakage Test

Conforms to North American Uniform Roadside Inspection Criteria

1. Park the vehicle on a level surface. Apply the parking brakes. Disconnect any attached or towed vehicles, semi-trailer, full trailer, dolly, etc. Leave the engine on.
2. Chock the tires.
3. Release the parking brakes.
4. With the compressor in pumping mode, engine at idle and service brakes fully applied, the gauge must stay between 80 to 90 psi, or gradually rise.

If pressure is not maintained, pressure drops, there is an air leak in the system.

Listen for air leaks. Soapy water or high frequency acoustic detectors may be used to detect air leaks. Make the necessary repairs.



WABCO
a **WORLD** of
DIFFERENCE

WABCO (NYSE: WBC) is a leading global supplier of technologies and services that improve the safety, efficiency and connectivity of commercial vehicles. Founded nearly 150 years ago, WABCO continues to pioneer breakthrough innovations for advanced driver assistance, braking, stability control, suspension, transmission automation and aerodynamics. Partnering with the transportation industry as it maps a route toward autonomous driving, WABCO also uniquely

connects trucks, trailers, cargo, drivers, business partners and fleet operators through advanced fleet management systems and mobile solutions. WABCO reported sales of \$2.8 billion in 2016. Headquartered in Brussels, Belgium, WABCO has 13,000 employees in 40 countries. For more information, visit:

www.wabco-na.com

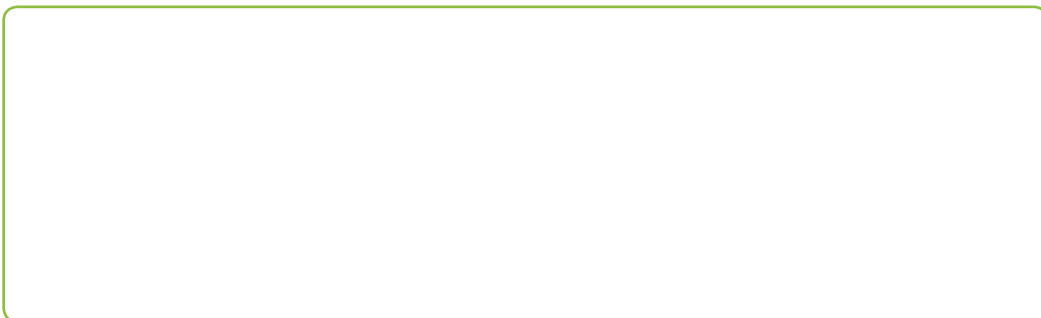

WABCO