

SYSTEM SAVER HP AIR DRYER

MAINTENANCE MANUAL



MM1736

WABCO

Table of Contents

Table of Contents

1	General Information.....	5
1.1	Symbols Used in this Document.....	5
1.2	How to Obtain Additional Maintenance, Service and Product Information.....	6
1.3	How to Obtain Parts and Kits.....	6
1.4	WABCO TOOLBOX PLUS™ Software.....	6
1.5	WABCO Academy.....	6
1.6	WABCO Online Product Catalog.....	6
1.7	Your Direct Contact to ZF CVS.....	7
2	Safety Information.....	8
2.1	Provisions for a safe work environment.....	8
3	Introduction.....	9
3.1	Overview.....	9
3.2	How the Air Dryer Works.....	9
3.3	Air Dryer Components.....	12
4	Component Removal and Installation.....	16
4.1	Component Replacement.....	16
4.2	Component Removal and Installation Procedures.....	17
5	Troubleshooting and Testing.....	24
5.1	Maintenance.....	24
5.2	Troubleshooting.....	25
6	Glossary.....	31
7	Application Information.....	32
7.1	Recommendations.....	32
7.2	System Saver Installation Criteria.....	33

Edition 1
Version 2 (04.2022)
MM1736 (en)

This publication is not subject to any update service. Information contained in this publication was in effect at the time the publication was approved for printing and is subject to change without notice or liability. ZF CV Systems North America LLC reserves the right to revise the information presented or to discontinue the production of parts described at any time.

You will find the current edition at: <https://zf.com/cvliterature>

General Information

1 General Information

1.1 Symbols Used in this Document

DANGER

Description of an immediate situation which will result in irreversible injury or death if the warning is ignored.

WARNING

Description of a possible situation which may result in irreversible injury or death if the warning is ignored.

CAUTION

Description of a possible situation which may result in irreversible injury if the warning is ignored.

NOTICE

Description of a possible situation which may result in material damage if the warning is ignored.



Important information, notices and/or tips



Reference to information on the Internet

Descriptive text

– Action step

1. Action step 1 (in ascending order)

2. Action step 2 (in ascending order)

⇒ Result of an action

• Listing

 Indicating the use of a tool / WABCO tool

General Information

1.2 How to Obtain Additional Maintenance, Service and Product Information

If you have any questions about the material covered in this publication, or for more information about the WABCO product line, please contact WABCO Customer Care Center at 855-228-3203, by email at wabconacustomercenter@zf.com, or visit our website: www.zf.com/cv.

Refer to the Society of Automotive Engineers (SAE) website to find all current SAE documents and standards applicable to WABCO products (such as SAE J447 and SAE J908 at www.sae.org).

Refer to the National Highway Traffic Safety Administration (NHTSA) website to find all current documents referenced in the manual at www.nhtsa.gov.

1.3 How to Obtain Parts and Kits

Contact the WABCO Customer Care Center at 855-228-3203 (United States and Canada); 800-953-0248 (Mexico). Email: wabconacustomercenter@zf.com.

1.4 WABCO TOOLBOX PLUS™ Software

TOOLBOX PLUS™ Software provides PC diagnostic for WABCO products and can be purchased and downloaded from <https://wabco.snapon.com>.

The software User Guide, MM19047 can be obtained by visiting our Literature Center.



Purchase and Download TOOLBOX PLUS™

<https://wabco.snapon.com>



ZF Commercial Vehicle Literature Center

<https://zf.com/cvliterature>

1.5 WABCO Academy



www.wabco-academy.com

1.6 WABCO Online Product Catalog



www.wabco-customercenter.com

General Information

1.7 Your Direct Contact to ZF CVS

ZF CV Systems North America LLC

1220 Pacific Drive
Auburn Hills, MI 48326

Customer Care Center: (855) 228-3203

www.zf.com/cv

wabconacustomer care@zf.com

Safety Information

2 Safety Information

2.1 Provisions for a safe work environment

- Only experienced, trained and qualified automotive technicians may carry out work on the vehicle.
- Read this publication carefully.
- Follow all warnings, notices and instructions to avoid personal injury and property damage.
- Always abide by the vehicle's Original Equipment Manufacturer (OEM) specifications and instructions.
- Observe all accident regulations of the repair facility as well as regional and national regulations.
- The workplace should be dry, sufficiently lit and ventilated.
- Use personal protective equipment if required (safety shoes, protective goggles, respiratory protection and ear protectors).

Read and observe all Danger, Warning and Caution hazard alert messages in this publication. They provide information that can help prevent serious personal injury, damage to components, or both.

WARNING

To prevent serious eye injury, always wear safe eye protection when you perform vehicle maintenance or service.

WARNING

Park the vehicle on a level surface. Block the wheels to prevent the vehicle from moving. Support the vehicle with safety stands. Do not work under a vehicle supported only by jacks. Jacks can slip or fall over. Serious personal injury and damage to components can result.

WARNING

This product can expose you to chemicals including Nickel, which is known to the State of California to cause cancer and birth defects or other reproductive harm. For more information, go to www.P65Warnings.ca.gov.

Introduction

3 Introduction

3.1 Overview

Maintenance Manual MM1736 contains troubleshooting steps and service information for the WABCO System Saver HP single cartridge air dryers.

If you have a WABCO System Saver (1200 or 1800) single cartridge air dryer, use MM34, WABCO System Saver Series (1200 and 1800) Single Cartridge Air Dryers. If you have a WABCO System Saver Twin air dryer, use MM35, WABCO System Saver Twin Air Dryer. To download these publications, go to zf.com/cvliterature.

3.1.1 Air Dryer Identification

The System Saver HP air dryer has the governor integrated into the body of the air dryer and also has an integrated purge tank.

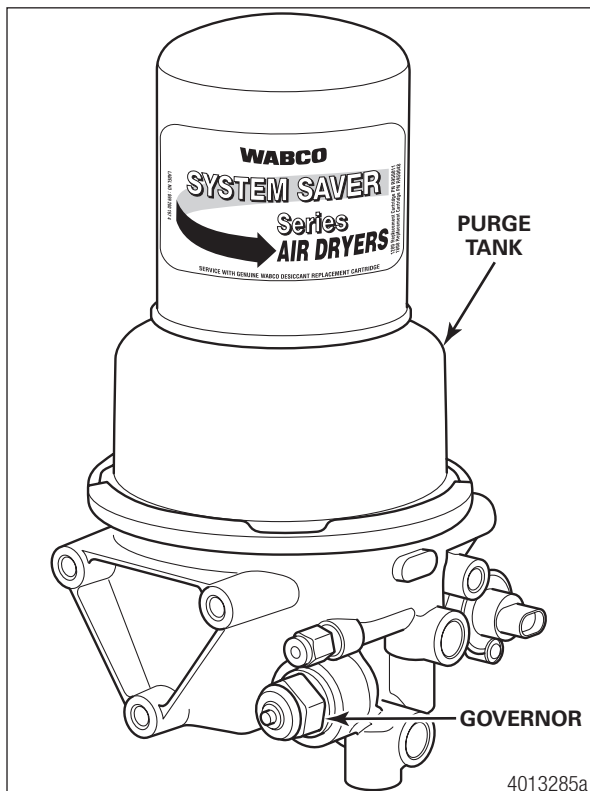

3.2 How the Air Dryer Works

During system pressure build-up, compressed air passes into the air dryer where the filter system removes contaminants and passes the air into the drying stage.

Moisture-laden air passes through the desiccant bed in the air dryer cartridge and moisture is retained by the desiccant. Moisture that condenses out also collects in the base of the dryer. When the compressor unloads, the water is expelled and dried air flows back through the dryer, drying the desiccant for the next cycle.

Introduction

3.2.1 Air Dryer Cycle

A single cartridge air dryer cycle is illustrated in Table A.

Table A: Air Dryer Cycle

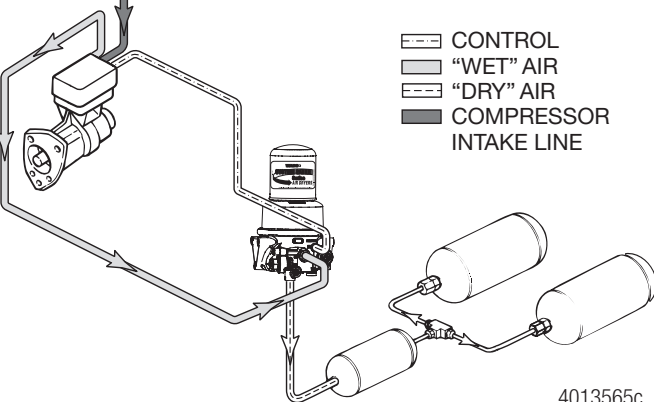
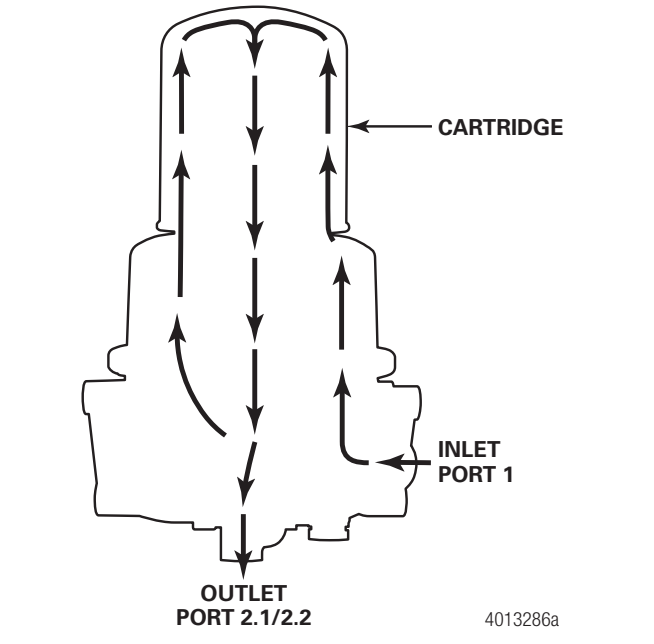
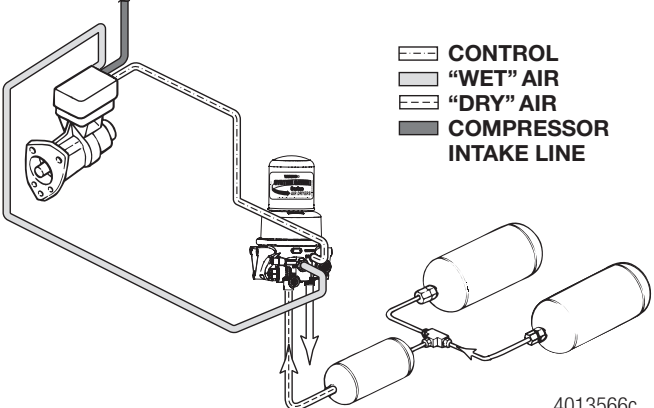
Cycle Stage	Air Flow
<p>The governor turns the compressor loading on when supply tank pressure drops below cut-in pressure, between 105-115 psi (724-792 kPa) depending on the governor settings.</p>	 <p style="text-align: right;">4013565c</p>
<p>Compressed air passes into the air dryer at the inlet port:</p> <ul style="list-style-type: none"> ■ Moisture-laden air and contaminants enter the desiccant. ■ Moisture is retained by desiccant; moisture also collects in the base of the dryer. ■ Contaminants are removed as air passes through the desiccant bed. 	 <p style="text-align: right;">4013286a</p>
<p>The governor unloads the compressor when the system reaches cut-out level 132 psi (910 kPa) +/-3 psi, depending on the governor settings.</p>	 <p style="text-align: right;">4013566c</p>

Introduction

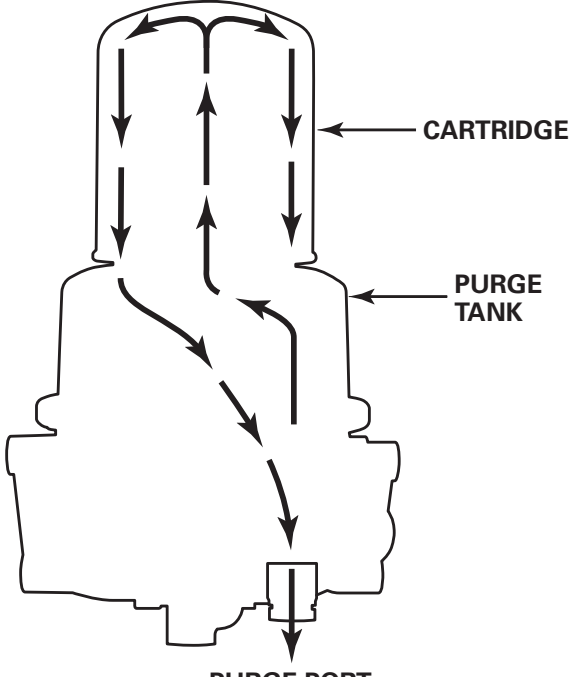
Cycle Stage	Air Flow
<p>When the compressor unloads, the purge valve opens. On the System Saver HP:</p> <ul style="list-style-type: none"> ■ Dry air flows from the integrated purge tank back through the air dryer. Air can be felt and heard flowing from the purge valve for an extended period of time. ■ Dry system air flows back through the air dryer to regenerate desiccant. 	 <p>The diagram shows a cross-section of the air dryer. At the top is the CARTRIDGE. Below it is the PURGE TANK. Arrows indicate air flowing upwards from the purge tank through the cartridge. At the bottom, a PURGE PORT 3.2 is shown with an arrow pointing downwards, indicating the exit of the purge air.</p> <p style="text-align: right;">4013569a</p>

3.2.2 System Saver HP Air Dryer System

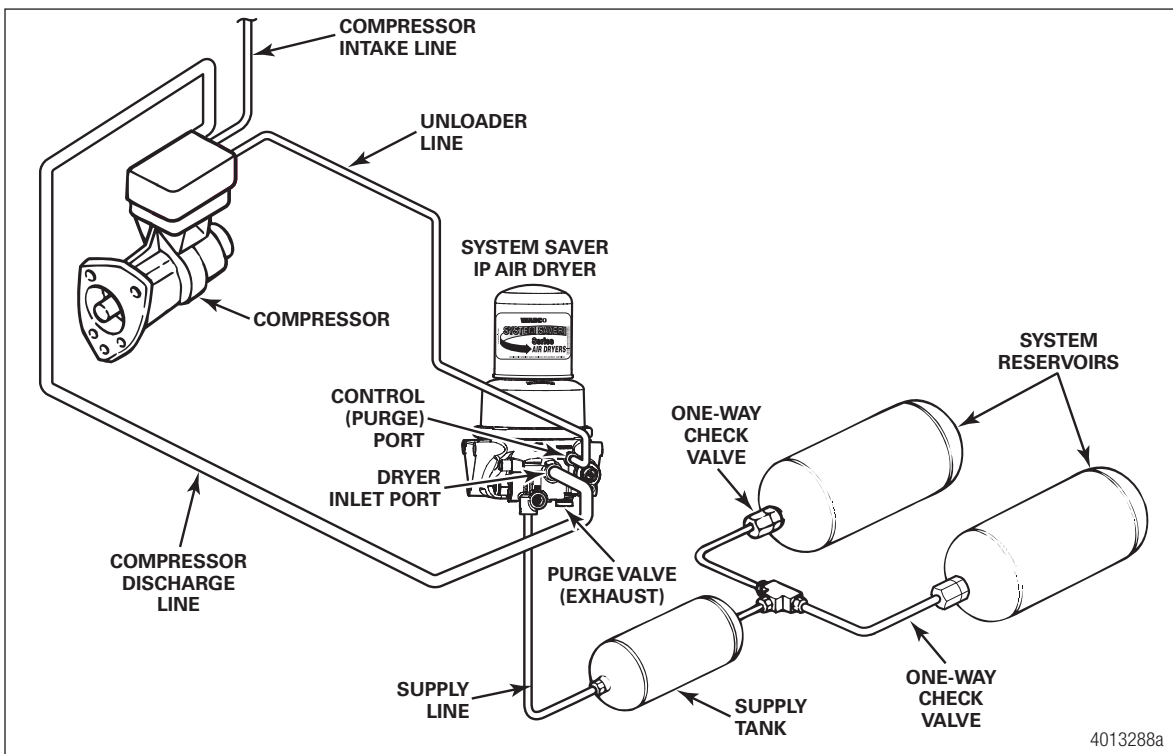

Introduction

3.3 Air Dryer Components

WABCO System Saver HP single cartridge air dryers contain replaceable component parts shown in the following figure. Refer to Section 4 for instructions for removal of old parts and installation of new parts.

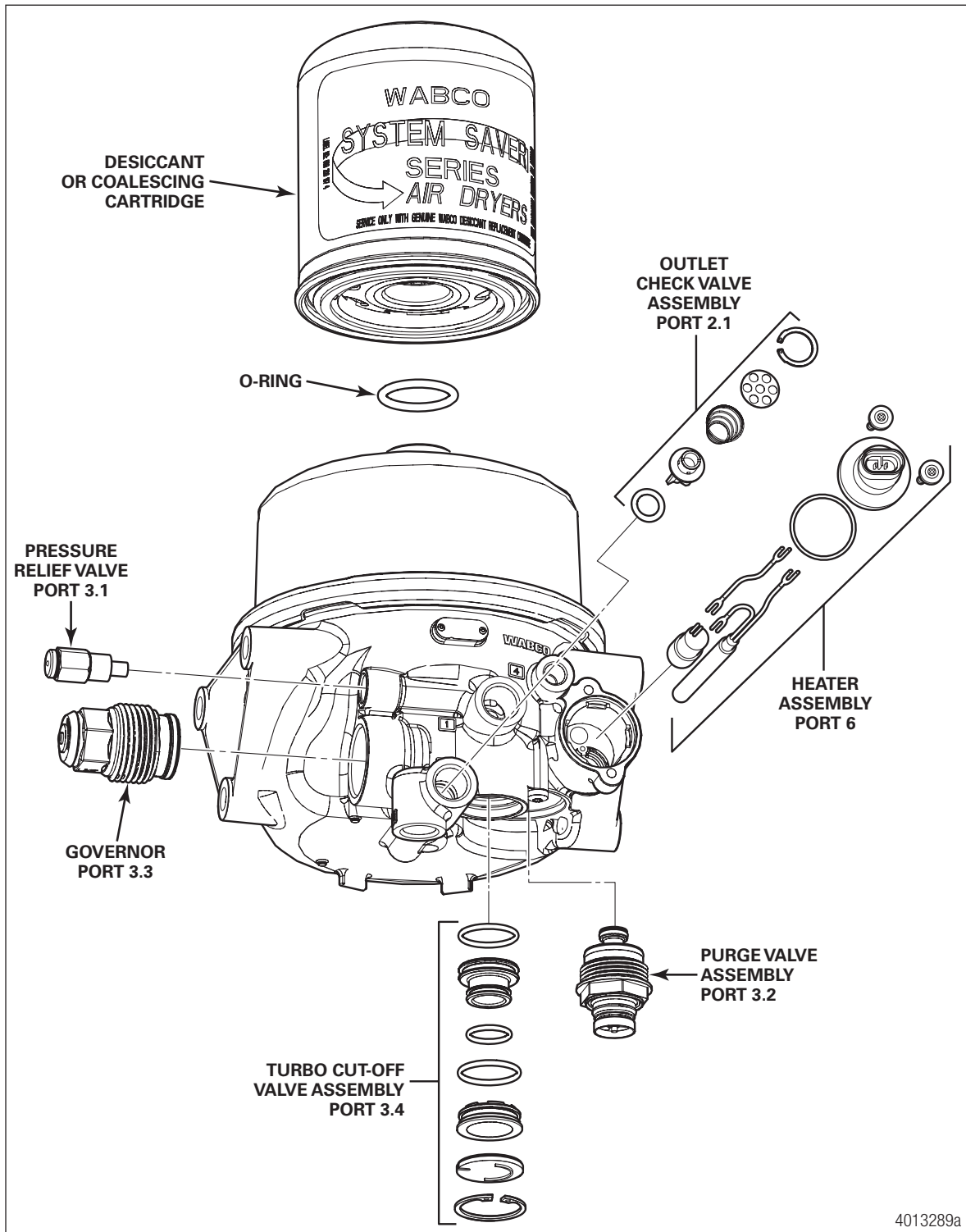

4013289a

Introduction

3.3.1 Dryer Identification Tag

The identification tag on the face of the dryer provides important information about the air dryer — information you will need when servicing or replacing components.

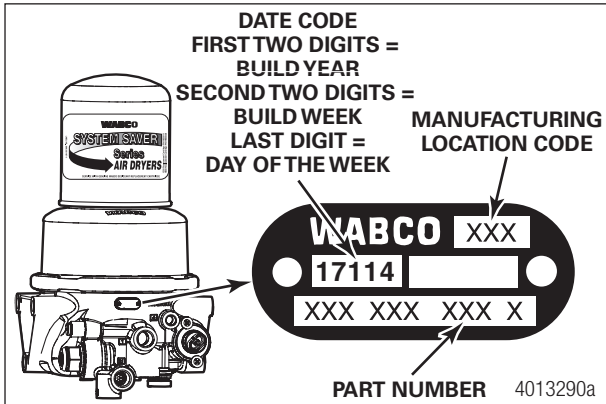

3.3.2 Description of Components

Replacement components for single canister air dryers are described below.

Spin-on/spin-off design allows quick and easy maintenance.

Always replace cartridges with authentic WABCO brand cartridges.

Coalescing Cartridge: Utilizes a filter element added to the standard desiccant to remove aerosols and oil particles.

Heater: Located in the air dryer base, the heater prevents water that collects in the air dryer from freezing. It consists of a cylindrical resistive-type heating element and a small circular thermostat. Heater is available for 12- and 24-volt air dryers.

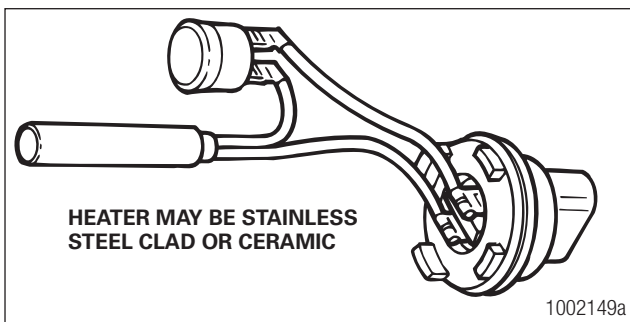

Outlet Check Valve: A valve located in the outlet port (port 21) of the air dryer. It prevents air from flowing back through the air dryer and escaping out the purge valve during a compressor unload cycle.

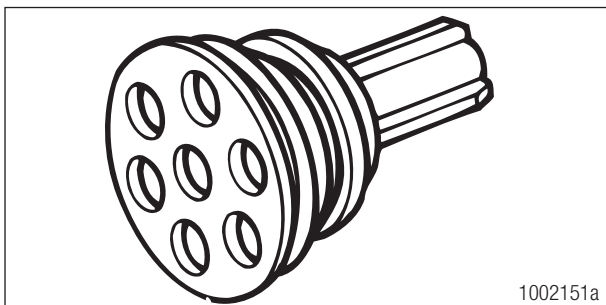

Introduction

Pressure Relief Valve: A valve that protects the air dryer from over-pressurization.

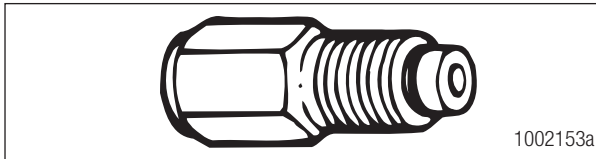

Purge Valve Assembly: A valve assembly located on the bottom of the air dryer base that remains open during a compressor unload cycle. It allows collected moisture, condensation and contamination to be expelled from the air dryer during a purge cycle.

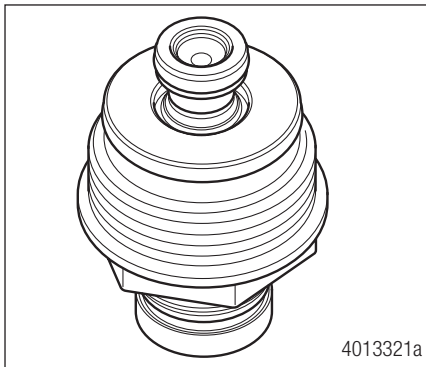

Turbo Cut-off Valve: A valve located in the inlet port of the air dryer. It closes the path between the air compressor and the air dryer purge valve during compressor unload. This prevents a loss of turbocharger boost pressure during a compressor unload cycle, thereby maintaining boost pressure for maximum engine horsepower (used exclusively on 1200 Plus and HP models).

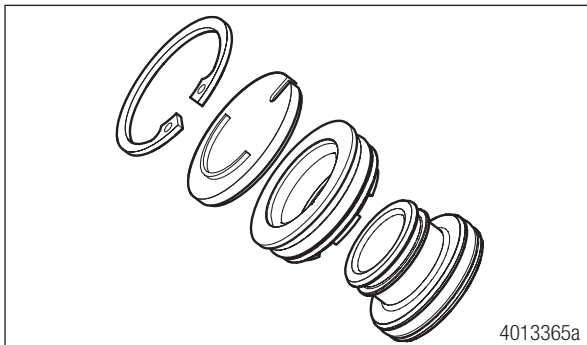

Heater Power Harness: Twelve-inch cable with Metri-Pack plug provides electrical connection to air dryer heating unit.

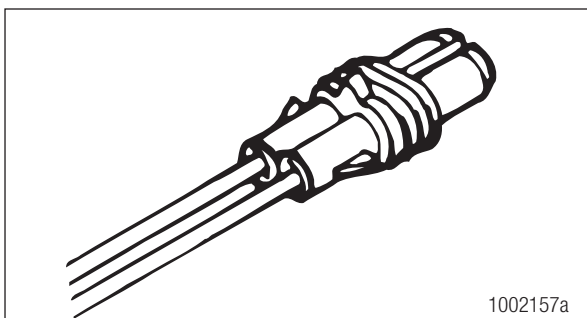

Introduction

Governor: Located in port 3.3 of the air dryer base. Controls the cut-in and cut-out pressure of the compressor.

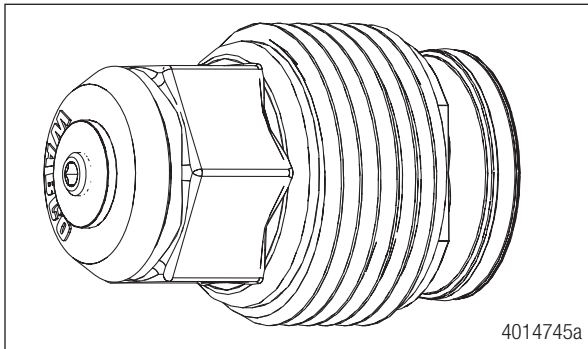

Component Removal and Installation

4 Component Removal and Installation

⚠ WARNING
To prevent serious eye injury, always wear safe eye protection when you perform vehicle maintenance or service.

⚠ WARNING
Park the vehicle on a level surface. Block the wheels to prevent the vehicle from moving. Support the vehicle with safety stands. Do not work under a vehicle supported only by jacks. Jacks can slip and fall over. Serious personal injury and damage to components can result.

⚠ WARNING
Remove all pressure from the air system before you disconnect any component, including the desiccant cartridge. Pressurized air can cause serious personal injury.

i The pressure protection elements are not serviceable on the System Saver HP. The entire dryer needs to be replaced if these parts are not operating effectively.

4.1 Component Replacement

4.1.1 Requirements

Refer to Table B for component replacement requirements. If necessary, you may also refer to Table E for System Saver Series air dryer troubleshooting. Before replacing any air dryer component, verify that the air compressor and air governor are working correctly, then drain the air tanks. Repair or replace these parts, if necessary. Check the entire air system for leaks, and repair as necessary. When draining air tanks before servicing the air dryer, check for water and/or oil that may have accumulated in the tanks. Water and/or oil in the air tanks could indicate a problem with the dryer or compressor.

Table B: Replacement Requirements

Component	When to Replace	Why
Cartridge	Every two to three years for standard desiccant.	Preventative maintenance.
	Every one to two years for coalescing.	
	When compressor is replaced.	Contaminated cartridge.
Heater Assembly	Water in supply tank.	Saturated or contaminated cartridge, high duty cycle (wrong application of air dryer).
	Water collecting in air dryer is freezing — electrical power to dryer is OK.	Heater assembly not working (internal short or open circuit).

Component Removal and Installation

Component	When to Replace	Why
Outlet Check Valve	Air continues to flow from purge valve after purge cycle, but stops flowing when the compressor load cycle begins.	Valve is stuck in the open position, or not functioning correctly.
	No pressure build-up in system, everything else is OK.	Valve is stuck in closed position.
Purge Valve	No purge cycle when compressor unloads — normal pressure at dryer control port 4 (governor port).	Valve is stuck in the closed position, or not functioning correctly.
	Air flows from purge valve during compressor's load cycle — no pressure at dryer control port.	Valve is stuck in the open position, or not functioning correctly.
Turbo Cut-Off Valve	Air compressor stuck pumping, TCU remains open. System will build pressure until safety valve opens in system.	Signal line loss.
	Air flows from purge valve during compressor unload cycle after purge cycle, and flow is noticeably stronger at high engine RPM, especially under load.	Turbo cut-off valve leaking.
	No pressure build-up in system — high compressor discharge line pressure.	Valve stuck in closed position.

4.2 Component Removal and Installation Procedures

WARNING

To prevent serious eye injury, always wear safe eye protection when you perform vehicle maintenance or service.

WARNING

Park the vehicle on a level surface. Block the wheels to prevent the vehicle from moving. Support the vehicle with safety stands. Do not work under a vehicle supported only by jacks. Jacks can slip and fall over. Serious personal injury and damage to components can result.

WARNING

Remove all pressure from the air system before you disconnect any component, including the desiccant cartridge. Pressurized air can cause serious personal injury.



The pressure protection elements are not serviceable on the System Saver HP. The entire air dryer needs to be replaced if these parts are not operating effectively



When replacing air dryer components, use only WABCO replacement parts.

The exploded view of the air dryer in Section 3 shows the location of the various air dryer components.

Component Removal and Installation

4.2.1 Desiccant Cartridge

i **IMPORTANT NOTE:** Refer to Table C for correct desiccant cartridge part numbers to use with the air dryer.

Table C: Replacement Cartridges

Air Dryer Part Number	Replacement Cartridge Part Number
432 480 001 0	432 901 238 2
432 480 101 0	432 901 238 2
432 480 141 0	R950068A
432 480 201 0	432 901 238 2
432 480 301 0	432 901 238 2
432 480 341 0	R950068A

1. Verify the replacement kit contains one cartridge and one O-ring.

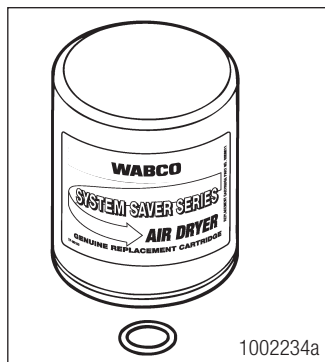

3. Loosen and remove the old cartridge. Use strap a wrench if necessary.
4. Remove and discard O-ring from dryer base.
5. Inspect and clean seal seat. Repair any minor damage.

i If the seal seats are damaged so badly that a tight seal cannot be maintained, replace the air dryer.

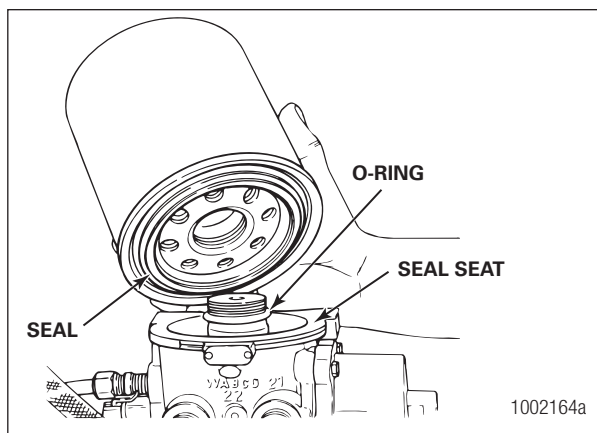

Component Removal and Installation

6. Lubricate and install the new O-ring on the stem.
7. Lubricate cartridge seal.
8. Thread the replacement cartridge onto the base until the seal touches the base. Then, tighten the cartridge **ONE** additional turn. **DO NOT OVERTIGHTEN**. If the cartridge will not fully spin on the dryer, the wrong cartridge is being use. Refer to the IMPORTANT NOTE and table.

4.2.2 Outlet Check Valve Assembly

1. Review the figure to ensure you have all of the parts required to replace the outlet check valve. Use the grease included with the replacement kit to lubricate the O-ring seal.

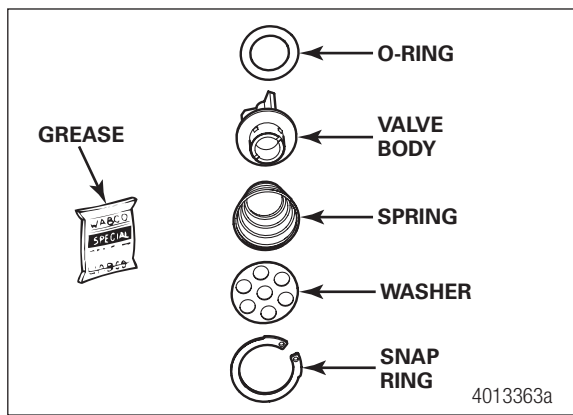

2. Remove the snap ring, washer, spring, valve body and O-ring.
3. Clean and inspect the valve bore. If the bore is damaged so that a tight seal cannot be maintained, replace the air dryer.
4. Install the new O-ring on the valve body.

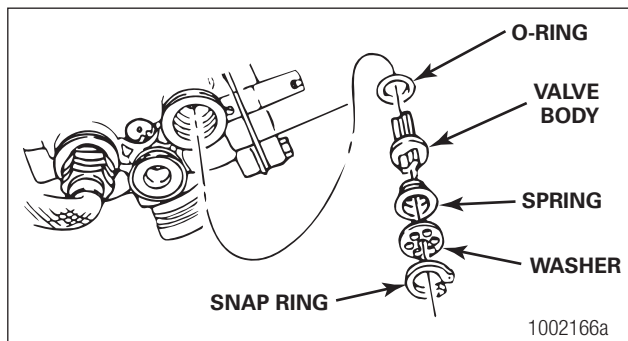

5. Apply a thin layer of grease from the kit to the valve bore and the O-ring.
6. Install the new valve body with its long end in the bore.
7. Install the new spring with its small end around the "Y"-shaped fins on the valve body.
8. Install the new washer and the new snap ring to hold the components in place.

Component Removal and Installation

4.2.3 Heater Assembly

1. Review the figure to ensure you have all of the parts required to replace the heater assembly.

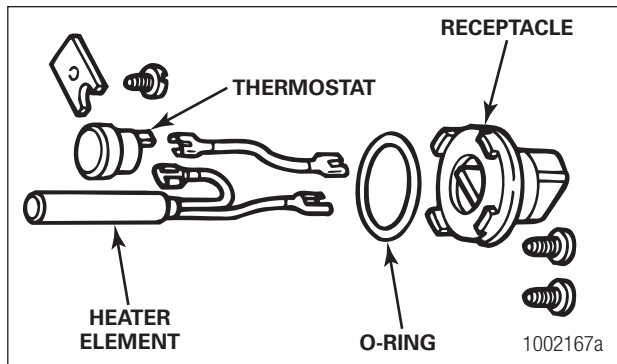

2. Disconnect the plug.
3. Remove the screws, receptacle and O-ring from the base to access the retainer screw.
4. Remove the retainer screw and then remove the entire heater assembly.
5. Install the O-ring to heater connector housing.
6. Install the new element and thermostat in their cavities.
7. Install the new retainer and screw to hold the element and the thermostat in place.
8. Install the receptacle and fasten it in place with the screws.

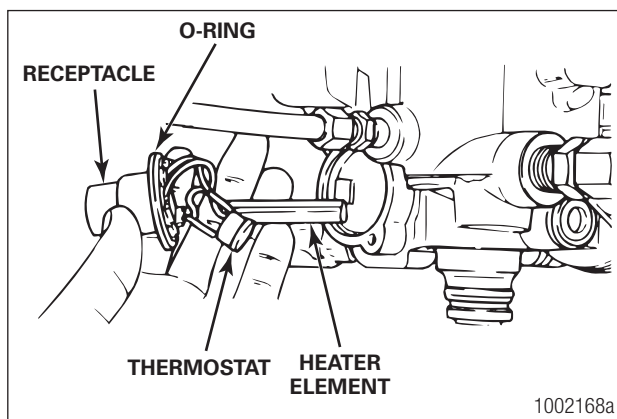

Component Removal and Installation

4.2.4 Turbo Cut-Off Valve Assembly



Use the grease included with the replacement kit to lubricate the O-rings and seals.

1. Remove the snap ring.

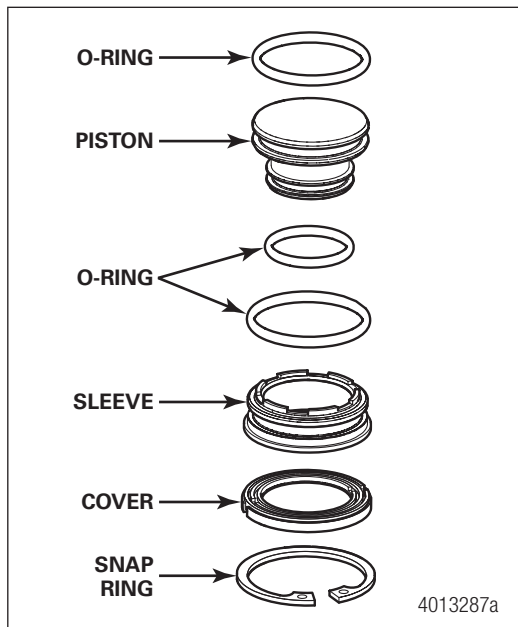

2. Remove the cover.
3. Remove the piston and sleeve.
4. Clean and inspect the valve bore. If the bore is damaged so that a tight seal cannot be maintained, replace the air dryer.
5. Apply a thin layer of grease to the valve bore and the O-rings.
6. Install new O-rings on the piston and sleeve.
7. Press the piston into the sleeve.
8. Press the piston-sleeve assembly into the air dryer.
9. Install the cover and snap ring.
10. Replace the desiccant cartridge using the detailed instructions provided earlier in this section.

Component Removal and Installation

4.2.5 Governor

Function — The governor controls the cut-in and cut-out pressure of the compressor through signal lines from the system reservoir as well as the compressor head controlling onload and offload.

 Use only the WABCO governor specified for use with the System Saver HP air dryer.

1. Using a 1-3/16" wrench, remove the governor from the air dryer.

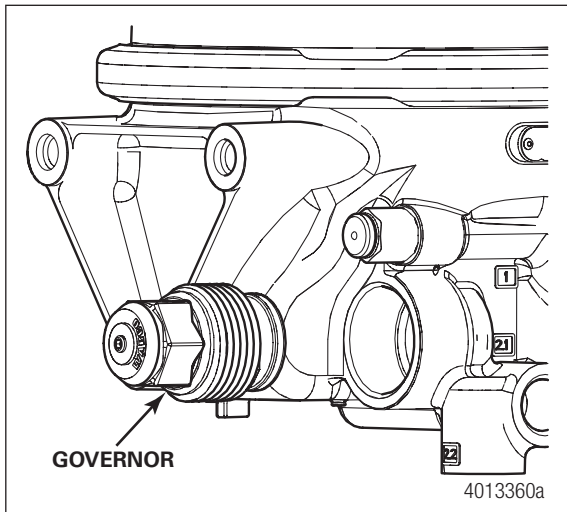

2. Install the new governor into the air dryer. Use a 1-3/16" wrench to tighten it to **no more** than 8.85 ft-lb (12 Nm).

4.2.6 Purge Valve Assembly

1. Use a 1-11/16" wrench to remove the purge valve assembly from the air dryer.

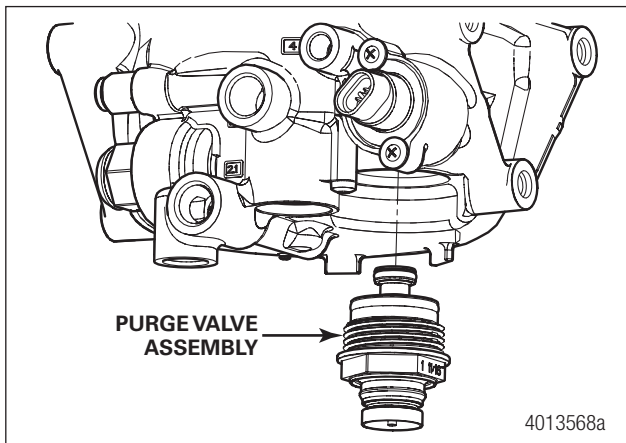

2. Clean and inspect the valve bore. If the bore is damaged so that a tight seal cannot be maintained, replace the air dryer.
3. Install the purge valve assembly in the air dryer. Use a 1-11/16" wrench to tighten it to no more than 11 ft-lb (15 Nm).

Component Removal and Installation

4.2.7 Air Dryer Assembly



This procedure is for removing and replacing a unit. For instructions on an initial installation, refer to TP92116, Installing the WABCO System Saver Air Dryer. To obtain this publication, go to zf.com/cvliterature.

1. Drain all pressure from the air system. Disconnect the air lines from port 1, port 2.2 and port 4. Use markers to label the lines for correct installation.
2. Disconnect the heater electrical plug from the heater receptacle.
3. Remove the three mounting bolts. Remove the air dryer from its mounting location.

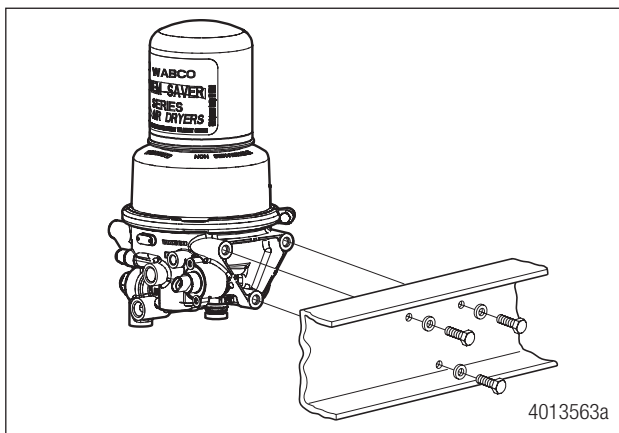

4. Attach the new unit to the frame or mounting bracket with new mounting bolts and washers. Tighten the bolts to 22-30 ft-lb (30-40 Nm).

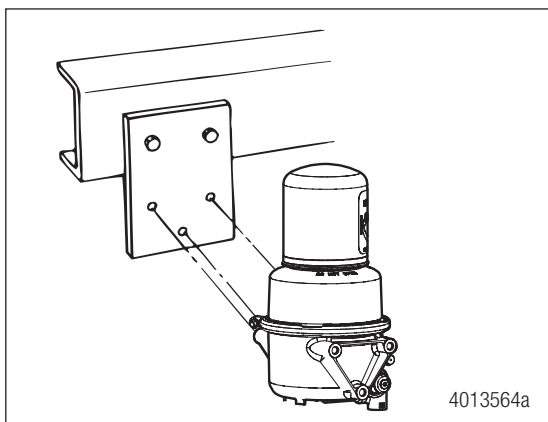

5. Connect the heater electrical plug to the heater receptacle.
6. Reconnect all system air lines.
7. Test the installation for correct operation. Refer to the procedure in this section.

Troubleshooting and Testing

5 Troubleshooting and Testing

⚠ WARNING

To prevent serious eye injury, always wear safe eye protection when you perform vehicle maintenance or service.

⚠ WARNING

Park the vehicle on a level surface. Block the wheels to prevent the vehicle from moving. Support the vehicle with safety stands. Do not work under a vehicle supported only by jacks. Jacks can slip and fall over. Serious personal injury and damage to components can result.

⚠ WARNING

Remove all pressure from the air system before you disconnect any component, including the desiccant cartridge. Pressurized air can cause serious personal injury.

5.1 Maintenance

To keep the air dryer operating efficiently, WABCO recommends the following routine maintenance.

Table D: Maintenance Schedule

Action	Interval
Ensure the dryer purges when compressor unloads.	Weekly
Check for moisture in the system by opening the drain cock on vehicle system reservoirs slowly.	Weekly, or as recommended by the manufacturer, whichever is most frequent.
Replace the standard desiccant cartridge.	Every two to three years, or more often depending on usage, vocation, and condition of compressor. Whenever compressor is rebuilt.
Replace the coalescing cartridge.	Every one to two years.

Troubleshooting and Testing

5.1.1 Maintenance Tips

With correct maintenance, the WABCO air dryer will provide years of reliable service, even under adverse operating conditions. To provide additional protection against the harmful effects of extreme heat or cold, here are a few helpful tips.

Extreme Heat

Make sure the compressor discharge line is long enough to keep the air dryer inlet air below 175°F (80°C). Refer to Section 7.

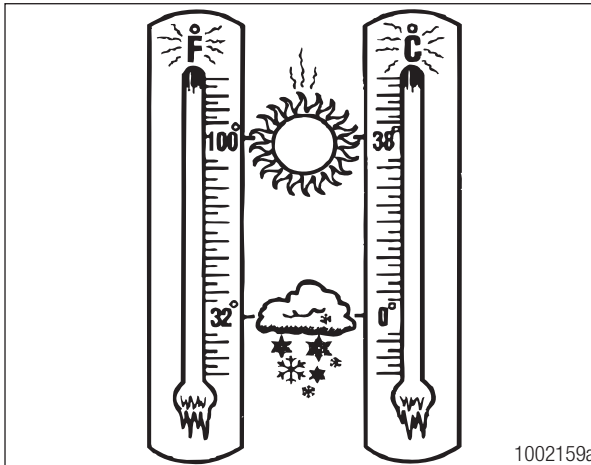

Extreme Cold

Make sure the air dryer heater is in good working order by running a heater resistance test. Refer to the procedure in this section.

Check the line from the compressor to port 4 of the dryer for oil and/or water. Keep this line clean to help prevent freezing.

WABCO air dryer components are installed in the air dryer at the factory and are designed to last for the life of the dryer. Under some operating conditions, however, a replacement may be required. Refer to Section 4 for replacement guide instructions.

5.2 Troubleshooting

Conditions you may experience, and suggested solutions, appear in Table E.



Refer to the exploded view of the air dryer in the illustration on page 12 for the location of dryer components.

Troubleshooting and Testing

Table E: System Saver HP Series Air Dryer Troubleshooting

Condition	Possible Cause	Solution
Dryer leaks from purge valve during compressor loaded cycle. The leak may cause excessive compressor cycling or prevent the system from building air pressure.	Purge valve frozen open (cold weather operation).	Check heater. Repair/replace if necessary. Make sure governor to dryer port 4 line is free of water/oil. Remove and inspect purge valve and clean water/oil from top of piston.
	Debris under purge valve seat, such as particles from fittings or air inlet line.	Remove purge valve cartridge and inspect for contamination. Remove if possible, or replace purge valve cartridge. Remove desiccant cartridge and clean sump area.
	Turbo cut-off valve is cracked or O-rings are leaking.	Remove turbo cut-off valve. Clean dryer bore and check for damage. Replace turbo cut-off valve if damaged component is found. Lubricate O-rings.
	Leaks in governor signal line between port 4 and compressor.	Repair signal line or fittings as necessary. Make sure downward slope of signal line from compressor to dryer.
Regeneration cycle too long (more than 30 seconds), accompanied by loss of pressure in the supply tank.	Outlet check valve not seating.	Inspect and replace outlet check valve as needed.
Regeneration cycle too short (less than 10 seconds).	High air system demands during compressor unloaded cycle.	Increase air system capacity or reduce air demands.
	Air governor not working correctly.	Verify that dryer governor is operating at correct pressures and that signal changes levels in one second or less. Replace if necessary.
No regeneration cycle. No airflow from purge valve after initial purge blast (dryer decompression).	Air dryer connections reversed at dryer.	Verify correct dryer installation per system diagram.
	Blocked/contaminated, internal dryer orifice	Replace dryer.
Air dryer does not purge when compressor unloads (no blast of air from purge valve).	Purge valve stuck closed.	Replace purge valve.
	Air governor not working correctly.	Inspect air governor. Repair/replace per instructions.
	Cut-out pressure never achieved by air compressor.	Check for air leaks in system and repair as needed. If no leaks in system, check compressor output. Repair/replace per manufacturer's instructions.

Troubleshooting and Testing

Condition	Possible Cause	Solution
Air dryer purges too often, perhaps as frequently as every 15 seconds, accompanied by excessive cycling of the compressor.	Leak in line between compressor and dryer port 4.	Repair air line.
	Line between the outlet of the dryer and the wet tank has a check valve installed.	Line between dryer and wet tank must be unobstructed.
	Leaks in the air system.	Repair leaks.
	Excessive air system demands.	Increase air system capacity or reduce air demand.
	Outlet check valve not seating.	Inspect and replace outlet check valve as needed.
	Leaking air compressor unloader(s).	Inspect compressor. Repair/replace per manufacturer's instructions.
On air dryers equipped with turbo cut-off valves, the air flows out of purge valve entire time compressor is unloaded. NOTE: On air dryers not equipped with turbo cut-off valves, the compressor unloads through the dryer, so a steady flow of air is normal.	Turbo cut-off valve not sealing.	Replace turbo cut-off valve.
	Outlet check valve not seating.	Replace outlet check valve.
Rapid "spitting" of air from purge valve in small amounts. Frequency varies with engine speed. NOTE: With non-TCV style air dryers, the compressor unloads through the dryer, so a steady flow of air is normal.	Compressor not completely unloading when cut-out pressure is reached. "Non-TCV" means a dryer with no turbo cut-off valve function.	Inspect compressor. Repair/replace per manufacturer's instructions. Make sure there are no leaks in the unloader signal line between the compressor and port 4 of the dryer.
Air dryer frozen (water collecting in base of dryer is freezing).	No electrical power to heater connector..	Check for a blown fuse. Repair heater circuit. NOTE: There must be power to the heater connector the entire time the vehicle's ignition is ON .
	Low voltage to heater connector.	Repair cause of low voltage, such as poor electrical ground, bad connections, corroded wire splices, etc.
	Heater assembly not working.	Replace heater assembly.
	Wrong voltage air dryer used; i.e., 12-volt air dryer used in a 24-volt system.	Replace with correct voltage air dryer.

Troubleshooting and Testing

Condition	Possible Cause	Solution
No air pressure build-up in system.	Air dryer not plumbed correctly (connections reversed).	Ensure compressor discharge line is plumbed to air dryer port 1, and air dryer port 21 or 22 is connected to vehicle's supply tank.
	Air governor not working correctly.	Inspect the governor and replace it, if needed, with a WABCO governor kit.
	Air system leaks, such as compressor discharge line, air dryer, reservoirs, brake or suspension valves, etc.	Locate leak(s) and repair.
	Air dryer leaks from purge valve.	Refer to purge valve conditions listed in this chart.
Water, oil, or sludge in air system tanks.	Desiccant contaminated with oil.	Replace desiccant. Inspect compressor per manufacturer's instructions.
Water in system tanks.	Desiccant saturated. Maintenance interval not followed.	Replace the desiccant cartridge with a genuine WABCO cartridge.
Water in system tanks, everything else checks out okay.	Dryer not suitable for application.	Review the application guidelines. Refer to TP9672. For assistance, call the WABCO Customer Care Center at 855-228-3203.

5.2.1 Tests

5.2.2 Heater Resistance

1. Set volt-ohmmeter to ohms.
2. Disconnect the vehicle harness at the heater.
3. Hold the leads together. Check the lead ohms. This value will be subtracted from the heater ohms in Step 5.
4. Place leads on the two pins on the heater connector at the air dryer.
5. Check the resistance. A resistance of 1.0-2.0 ohms should be seen for a 12-volt heater assembly and 5.0-7.0 ohms should be seen for a 24-volt heater assembly.
 - If there is correct resistance on the dryer side and there is sufficient voltage at the harness, the heater is functioning correctly. Reinstall the components and harness.
 - If resistance is less than 1.0 ohm for a 12-volt heater assembly or 5.0 ohms for a 24-volt heater assembly, replace the heater.

To avoid damaging components, WABCO recommends performing this resistance check with the heater in place.



The dryer temperature must be in thermostat closed range (below 35°F [1.65°C]) in order to check heater resistance.

Troubleshooting and Testing

5.2.2.1 Electric Power to Dryer

1. Set the volt-ohmmeter to volts.
2. Disconnect the vehicle harness at the heater.
3. Add a small electrical lead at the wire harness connector.
4. Place leads on each pin of the wiring harness connector.
5. If there is an abnormal voltage reading, inspect the wiring harness, wires and fuses.

5.2.2.2 Leak Test

1. Drain air from all system tanks.
2. Close reservoir draincocks.
3. Start the vehicle. Allow air system pressure to build while engine idles.
4. When the system reaches cut-out pressure there will be a purge, or strong blast of air, followed by a mild flow which will last 10-45 seconds.
5. Shut off the engine.
6. Apply a soap solution to each connection that contains pressurized air. Check the connections to see if soap solution bubbles.
 - No Soap Bubbles: Connections are sealed correctly.
 - Soap Bubbles Appear: Connections are NOT sealed correctly.

To Repair Incorrectly Sealed Connections

1. Drain all reservoirs.
2. Remove leaking connection.
3. Inspect the connectors and ports for damaged threads or cracks. Replace if necessary.
4. Apply pipe sealant to the connection.
5. Repeat leak test until all connections are sealed.

5.2.3 Air Pressure Checks

When checking air pressure during these tests, do not rely on cab air gauges for accurate readings. Install a calibrated air gauge, accurate to within one psi (7 kPa), in the air tank to determine if air pressure is within the required ranges.

5.2.3.1 Operational Test for System Saver Series Air Dryers

1. Check compressor loaded and unloaded cycle.
When the compressor is in the **loaded cycle**, air pressure will build to approximately 120-140 psi (827-965 kPa) (cut-out pressure). When the compressor reaches the **unloaded cycle**, the air dryer will purge, initiating regeneration of the air dryer.
2. Verify that there is no visible pressure drop in the tanks during regeneration. If there is a visible pressure drop, perform a check valve leak test on the system check valves.

Troubleshooting and Testing

5.2.3.2 Turbo Cut-Off Valve (Pertains only to dryers equipped with turbo cut-off valves)

1. Wear safe eye protection. Park the vehicle on a level surface. Block the wheels to prevent the vehicle from moving. Set the parking brake.
2. Pump the air system down by making brake applications until the system pressure gauge shows just below cut-in pressure, typically 100 psi (6.89 bar).
3. Start the vehicle.
4. While the compressor is pumping, inspect for air coming out of the bottom of the air dryer.
 - If air is coming out of the bottom of the TCV or the governor exhaust vent, replace the TCV using the procedure in this maintenance manual.
5. If the TCV is not leaking, continue to run the engine until the compressor builds the system to cut-out pressure, typically 130 psi (8.96 bar)
6. When cut-out pressure is reached, verify that the air dryer purges. There will be a loud blast of air from the purge valve followed by a gentle flow of air lasting about 30 seconds. After 30 seconds, all flow of air from the purge valve should stop.
 - If air continues coming out of the bottom of the TCV, replace the TCV using the procedure in this technical bulletin.
 - If the compressor and air dryer constantly cycle several times before cut-out pressure is reached, replace the TCV using the procedure in this technical bulletin. If the compressor and the air dryer continue to cycle frequently after you replace the TCV, replace the governor.

Glossary

6 Glossary

Table F: Basic Air Dryer System/Air Dryer Terms

Term	Definition
Air Compressor	A device that pumps air to and builds air pressure in an air system.
Air Dryer	A device that cools, filters and dries the air delivered by an air compressor.
Air Governor	A device that controls the operation of the air compressor by constantly monitoring air pressure in the supply tank of the air system. The air governor initiates the compressor load cycle when “cut-in” pressure is realized, and initiates the compressor unload cycle when the “cut-out” pressure is reached. The air governor also controls the air dryer by sending an air signal (at the beginning of the compressor unload cycle) to the control port of the air dryer, initiating the purge cycle. When this air signal is removed by the governor (at the beginning of the compressor load cycle), the purge valve closes and the drying cycle begins.
Compressor Load Cycle	The time during which the air compressor is building air pressure in an air system.
Compressor Unload Cycle	The time during which the air compressor is idling and is not building air pressure in an air system.
Cut-In Pressure	The pressure level in the air system supply tank which triggers the compressor load cycle.
Cut-Out Pressure	The pressure level in the air system supply tank which triggers the compressor unload cycle.
Dedicated Purge Tank	A separate air tank used exclusively for holding air used in an air drying cycle. This tank eliminates the need for a regeneration valve. Optimum mounting location for the dedicated purge tank is ABOVE the air dryer.
Desiccant	A granular substance that has a high affinity for water and is used to retain moisture from the air stream flowing through the air dryer cartridge.
Discharge Line - Unloaded Compressor	An unloader or air discharge line used to dump unused air to atmosphere once system has reached cut-out pressure.
Drying Cycle	The time during which the air dryer cools, filters and removes moisture from the air delivered by the air compressor. The drying cycle begins and ends the same as the compressor load cycle.
Purge	The initial blast of air (decompression) from the air dryer purge valve at the beginning of the unload cycle of the air compressor.
Purge Cycle	The time during which the air dryer is undergoing purge and regeneration. This cycle starts at the beginning of the compressor unload cycle and normally ends well before the beginning of the compressor load cycle.
Regeneration	The mild backflow of air through the air dryer and out the purge valve that begins immediately after the purge and lasts normally 10 to 25 seconds. This backflow of air from the air system and through the air dryer removes moisture from the desiccant cartridge and readies the air dryer for the next compressor load cycle.

Application Information

7 Application Information

7.1 Recommendations



For complete installation and operating requirements, refer to TP9672, Air Dryer Application Guidelines. To download this publication, go to zf.com/cvliterature.

- Compressor discharge line should have a continual downhill run to the air dryer. There should be no water traps (low points or kinks) in the line before or after the dryer.
- Mount air dryer so that there is no direct splash or spray from a wheel.
- Keep air dryer at least 12" (305 mm) from any heat-producing sources like exhaust manifolds or pipes, transmissions, etc.
- Make sure there are no valves or other devices in the dryer-to-supply-tank line to prohibit or restrict the flow of air back from the supply tank to the air dryer.

7.1.1 Operating Environment

Table G: Operating Parameters

Operating Parameter	Requirement
Temperature (ambient operating range)	-40°F to 175°F (-40°C to 80°C)
Electrical Power (for heater and solenoid/timer power)	12 or 24 volts available
Thermostat Range (On/Off temp)	45°F, 86°F (7°C, 30°C)

7.1.2 Discharge Line

- Diameter from compressor to air dryer
 - 5/8-inch (15.875 mm) ID minimum for 25.5 cfm and under
 - 3/4-inch (19.05 mm) ID minimum for over 25.5 cfm



IMPORTANT NOTE: Line size and fittings must comply with the compressor manufacturer's guidelines for backpressure and peak pressure.

- Length from compressor to air dryer
Determined by temperature of air at the inlet port of the air dryer. At normal vehicle operating temperature, the combination of length or increased diameter must be sufficient to keep temperature **BELOW 175°F (80°C)**.

Application Information

7.2 System Saver Installation Criteria

Table H: Installation Criteria

Operating Parameters	Signal Name	Wire Color
Pressure requirements	Maximum pressure	140 psi (965 kPa)
	Minimum governor cut-out pressure	115 psi (793 kPa)
	Governor range	15 to 25 psi (103 to 172 kPa) (cut-out — cut-in)
Flow capacity	Compressor rating	All naturally aspirated compressors up to 38.8 cfm
Compressor on-time	Normal running	Two minutes maximum
	Occasional (three times per day maximum)	Seven minutes
Compressor unloaded time	Minimum for purge cycle	20 seconds
Maximum duty cycle	Compressor on-time total running time	30%
Discharge line	Temperature at inlet port determines required length and diameter	To minimize the likelihood of a discharge line blockage during cold climate operation, it is recommended that for discharge lines exceeding nine feet (2.75 m) in length, a minimum of three feet (0.91 m) of 1/2-inch (127 mm) thick closed-cell polyethylene pipe insulation be used at the connection to the air dryer.

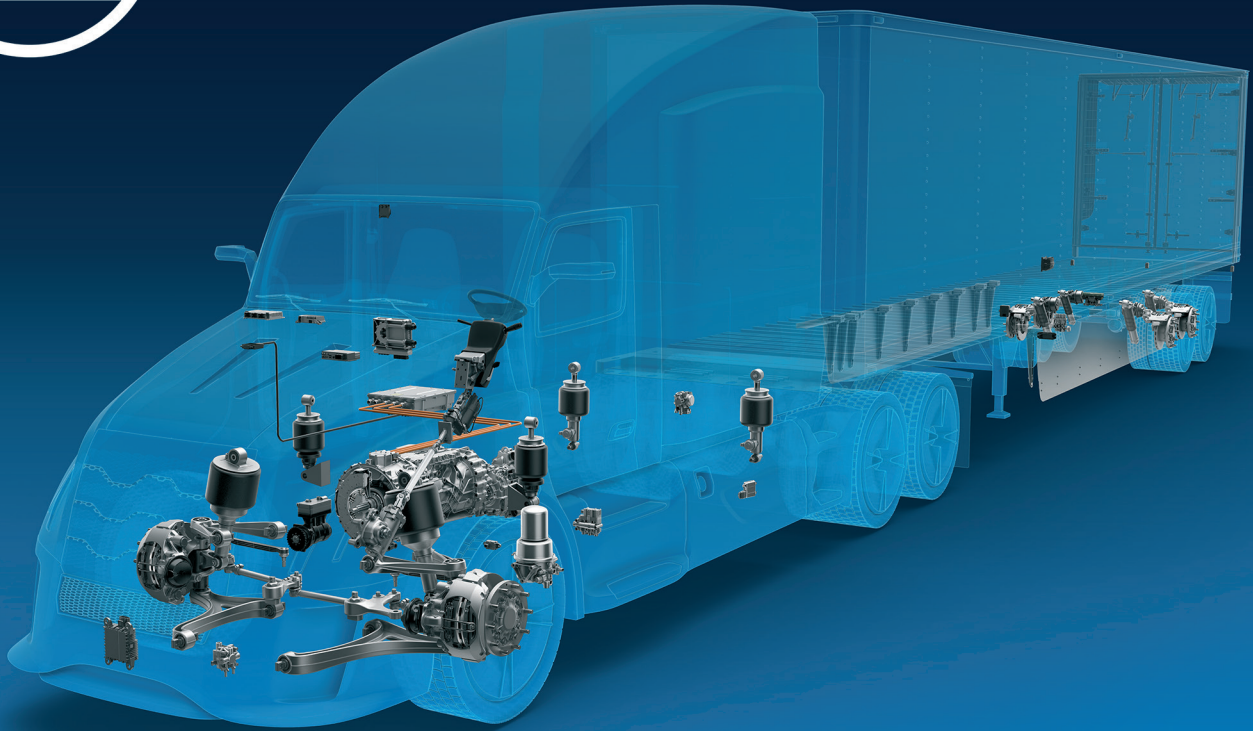

**For further details, contact the
WABCO Customer Care Center at 855-228-3203.**

About CVS Division

ZF's Commercial Vehicle Solutions (CVS) division is helping shape the future of commercial transportation ecosystems. Our mission is to be the preferred global technology partner to the commercial vehicle industry. Powerfully combining ZF's commercial vehicle systems expertise, extensive technology portfolio and global operations, the division serves the full commercial vehicle industry value chain. As the automotive industry progresses towards an increasingly autonomous, connected, and electrified (ACE) future, ZF's CVS division innovates, integrates and supplies components and advanced control systems that help make commercial vehicles and fleets operate more safely and sustainably. CVS unites ZF's former Commercial Vehicle Technology and Commercial Vehicle Control Systems divisions, the latter being formed following ZF's acquisition of WABCO in Spring 2020.

For more information, visit: www.zf.com/cv

WABCO