



Systems Operation Testing and Adjusting

C4.4 Industrial Engine

4481-Up (Engine)

Important Safety Information

Most accidents that involve product operation, maintenance and repair are caused by failure to observe basic safety rules or precautions. An accident can often be avoided by recognizing potentially hazardous situations before an accident occurs. A person must be alert to potential hazards. This person should also have the necessary training, skills and tools to perform these functions properly.

Improper operation, lubrication, maintenance or repair of this product can be dangerous and could result in injury or death.

Do not operate or perform any lubrication, maintenance or repair on this product, until you have read and understood the operation, lubrication, maintenance and repair information.

Safety precautions and warnings are provided in this manual and on the product. If these hazard warnings are not heeded, bodily injury or death could occur to you or to other persons.

The hazards are identified by the "Safety Alert Symbol" and followed by a "Signal Word" such as "DANGER", "WARNING" or "CAUTION". The Safety Alert "WARNING" label is shown below.



The meaning of this safety alert symbol is as follows:

Attention! Become Alert! Your Safety is Involved.

The message that appears under the warning explains the hazard and can be either written or pictorially presented.

A non-exhaustive list of operations that may cause product damage are identified by "NOTICE" labels on the product and in this publication.

Caterpillar cannot anticipate every possible circumstance that might involve a potential hazard. The warnings in this publication and on the product are, therefore, not all inclusive. You must not use this product in any manner different from that considered by this manual without first satisfying yourself that you have considered all safety rules and precautions applicable to the operation of the product in the location of use, including site-specific rules and precautions applicable to the worksite. If a tool, procedure, work method or operating technique that is not specifically recommended by Caterpillar is used, you must satisfy yourself that it is safe for you and for others. You should also ensure that the product will not be damaged or become unsafe by the operation, lubrication, maintenance or repair procedures that you intend to use.

The information, specifications, and illustrations in this publication are on the basis of information that was available at the time that the publication was written. The specifications, torques, pressures, measurements, adjustments, illustrations, and other items can change at any time. These changes can affect the service that is given to the product. Obtain the complete and most current information before you start any job. Cat dealers have the most current information available.



When replacement parts are required for this product Caterpillar recommends using Cat replacement parts or parts with equivalent specifications including, but not limited to, physical dimensions, type, strength and material.

Failure to heed this warning can lead to premature failures, product damage, personal injury or death.

In the United States, the maintenance, replacement, or repair of the emission control devices and systems may be performed by any repair establishment or individual of the owner's choosing.

Table of Contents

Systems Operation Section

General Information

Introduction	4
--------------------	---

Engine Operation

Basic Engine	10
Air Inlet and Exhaust System (Single Turbocharger)	14
Air Inlet and Exhaust System (Series Turbochargers)	20
Clean Emissions Module	25
Cooling System	27
Lubrication System	29
Electrical System	29
Cleanliness of Fuel System Components	31
Fuel Injection	31
Electronic Control System	39
Power Sources	52
Glossary of Electronic Control Terms	55

Testing and Adjusting Section

Fuel System

Fuel System - Inspect	61
Air in Fuel - Test	61
Finding Top Center Position for No. 1 Piston	63
Fuel Injection Timing - Check	64
Fuel Quality - Test	65
Fuel System - Prime	65
Gear Group (Front) - Time	66

Air Inlet and Exhaust System

Air Inlet and Exhaust System - Inspect	67
Turbocharger - Inspect (Series Turbochargers)	68
Turbocharger - Inspect (Single Turbocharger)	71
Exhaust Cooler (NRS) - Test	74
Compression - Test	75
Engine Valve Lash - Inspect	75
Valve Depth - Inspect	77
Valve Guide - Inspect	78

Lubrication System

Engine Oil Pressure - Test	79
Engine Oil Pump - Inspect	79
Excessive Bearing Wear - Inspect	80
Excessive Engine Oil Consumption - Inspect	80
Increased Engine Oil Temperature - Inspect	81

Cooling System

Cooling System - Check	82
Cooling System - Inspect	82
Cooling System - Test	83
Engine Oil Cooler - Inspect	84
Water Temperature Regulator - Test	85
Water Pump - Inspect	85

Basic Engine

Position the Valve Mechanism Before Maintenance Procedures	86
Piston Ring Groove - Inspect	86
Connecting Rod - Inspect	87
Cylinder Block - Inspect	88
Cylinder Head - Inspect	88
Piston Height - Inspect	89
Flywheel - Inspect	90
Flywheel Housing - Inspect	91
Gear Group - Inspect	92
Crankshaft Pulley - Check	93

Electrical System

Alternator - Test	94
Battery - Test	95
Charging System - Test	96
V-Belt - Test	96
Electric Starting System - Test	96

Index Section

Index	99
-------------	----

Systems Operation Section

General Information

i04129192

Introduction

SMCS Code: 1000

The C4.4 diesel engine is electronically controlled. The C4.4 engine has an Electronic Control Module (ECM) that receives signals from the fuel injection pump and other sensors in order to control the electronic unit injector. The fuel injection pump supplies fuel to the high-pressure manifold (Rail). The high-pressure manifold (Rail) distributes fuel to the electronic unit injectors.

The four cylinders are arranged in-line. The cylinder head assembly has two inlet valves and two exhaust valves for each cylinder. The ports for the exhaust valves are on the right side of the cylinder head. The ports for the inlet valves are on the left side of the cylinder head. Each cylinder valve has a single valve spring.

Each cylinder has a piston cooling jet that is installed in the cylinder block. The piston cooling jet sprays engine oil onto the inner surface of the piston in order to cool the piston. The pistons have a Quiescent combustion chamber in the top of the piston in order to achieve clean exhaust emissions. The piston pin is off-center in order to reduce the noise level.

The pistons have two compression rings and an oil control ring. The groove for the top ring has a hard metal insert in order to reduce wear of the groove. The skirt has a layer of graphite in order to reduce the risk of seizure when the engine is new. The correct piston height is important in order to ensure that the piston does not contact the cylinder head. The correct piston height also ensures the efficient combustion of fuel which is necessary in order to conform to requirements for emissions.

The crankshaft has five main bearing journals. End play is controlled by thrust washers which are located on both sides of the number 3 main bearing.

The timing case is made of aluminum or cast iron. The timing gears are stamped with timing marks in order to ensure the correct assembly of the gears. When the number 1 piston is at the top center position of the compression stroke, the marked teeth on the idler gear will align with the marks that are on the fuel injection pump gear, the camshaft gear, and the gear on the crankshaft. There are no timing marks on the rear face of the timing case.

The crankshaft gear turns the idler gear which then turns the following gears:

- the camshaft gear
- the accessory drive gear (if equipped)
- the fuel injection pump gear
- the water pump gear

The camshaft runs at half the rpm of the crankshaft. The fuel injection pump runs at the same rpm as the crankshaft.

The fuel injection pump that is installed on the left side of the engine is gear-driven from the timing case. The fuel is transferred to the fuel injection pump by an external electric transfer pump. The electric transfer pump draws fuel across a suction strainer that supplies fuel to the primary fuel filter and the secondary fuel filter. The fuel then travels to the fuel injection pump. A pressure regulator that is installed in the low-pressure fuel system controls the fuel pressure to the fuel injection pump. The pressure regulator regulates the fuel at an absolute pressure of 150 kPa (22 psi) when the engine is at idle speed.

The fuel injection pump increases the fuel to a maximum pressure of 200 MPa (2900 psi). The fuel injection pump delivers the fuel to the high-pressure manifold (Rail). The fuel injection pump is not serviceable. The engine uses speed sensors and the Electronic Control Module to control the engine speed.

For the specifications of the C4.4 engine, refer to the Specifications, "Engine Design".

The following model views show a typical C4.4 engine. Due to individual applications, your engine may appear different from the illustrations.

C4.4 Engine with Series Turbochargers

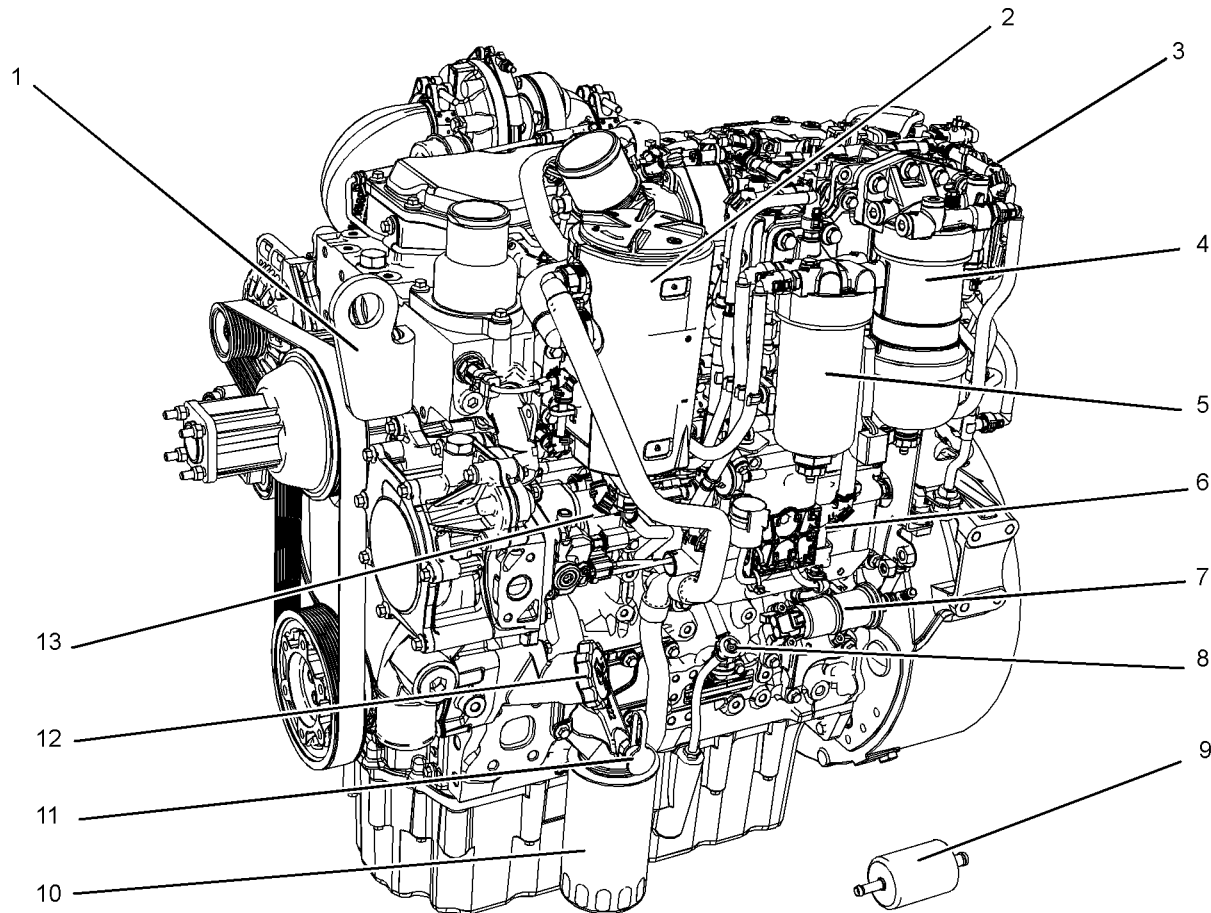

Illustration 1

g02409511

Typical example

- | | | |
|--------------------------------|-------------------------------------|--------------------------|
| (1) Front lifting eye | (6) Electronic Control Module (ECM) | (11) Oil sampling valve |
| (2) Crankcase breather | (7) Fuel priming pump | (12) Oil filler |
| (3) NOx Reduction System (NRS) | (8) Oil gauge (dipstick) | (13) Fuel injection pump |
| (4) Primary fuel filter | (9) Fuel strainer | |
| (5) Secondary fuel filter | (10) Oil filter | |

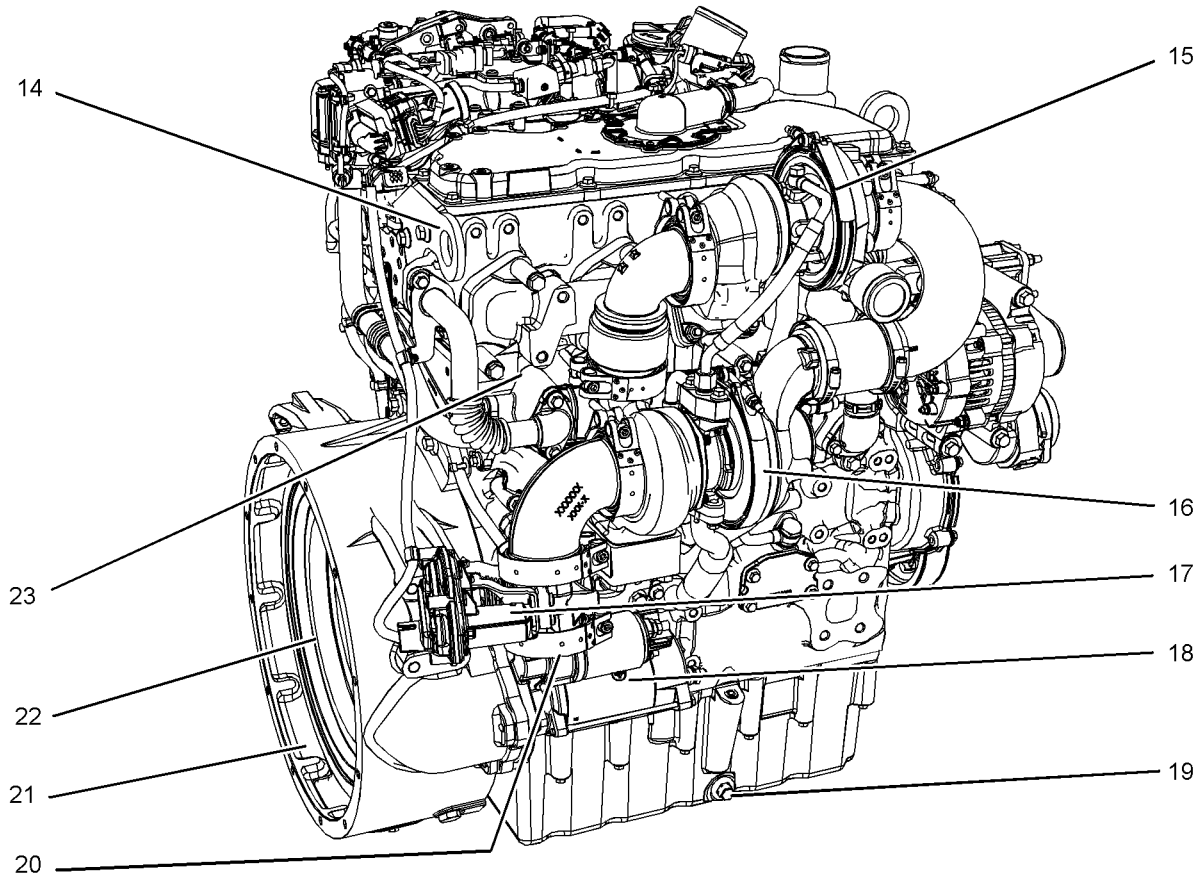

Illustration 2

g02409512

Typical example

- (14) Rear lifting eye
- (15) High-pressure turbocharger
- (16) Low-pressure turbocharger
- (17) Back pressure valve

- (18) Starting motor
- (19) Oil drain plug
- (20) Exhaust outlet
- (21) Flywheel housing

- (22) Flywheel
- (23) Exhaust gas cooler (NRS)

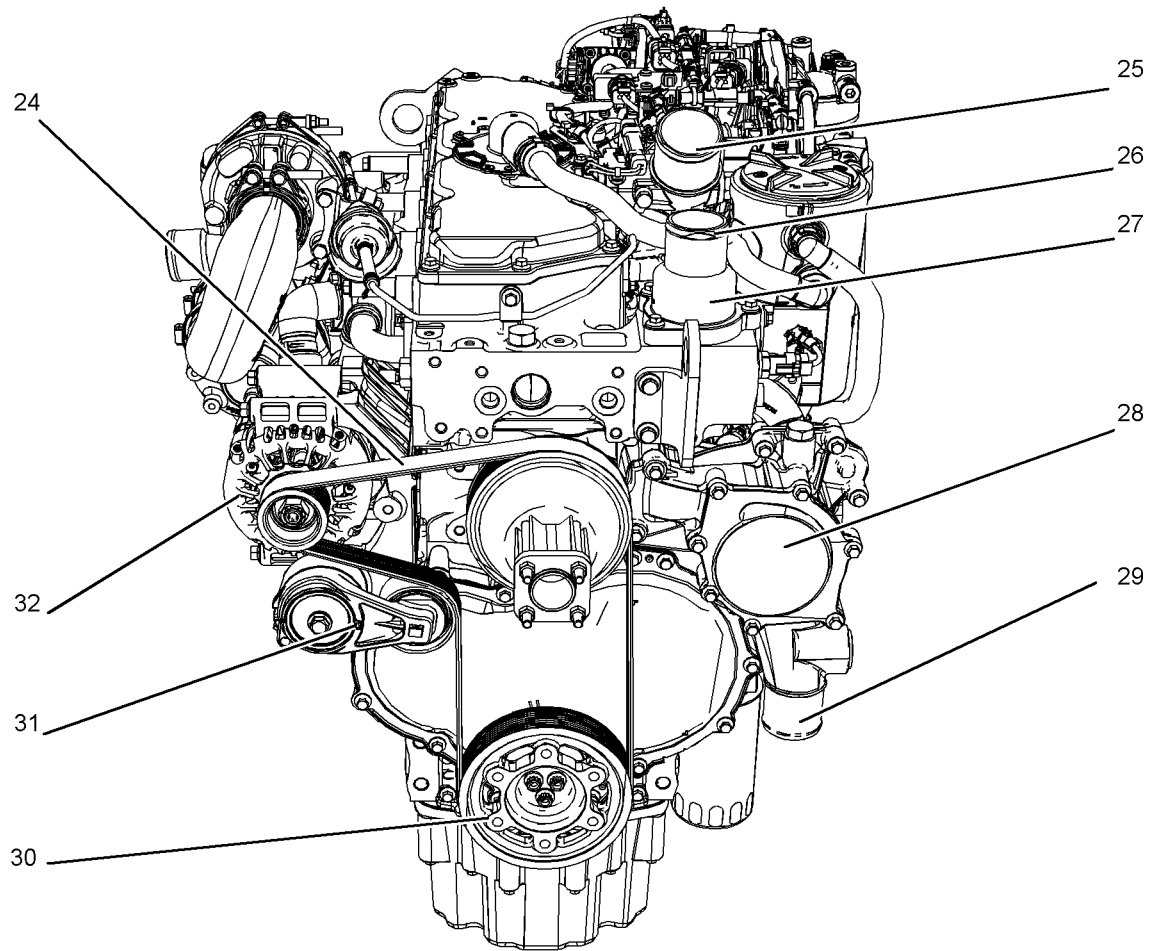

Illustration 3

g02409862

Typical example

- | | | |
|--------------------------------|--|------------------------|
| (24) Belt | (27) Water temperature regulator housing | (30) Crankshaft pulley |
| (25) Connection for air inlet | (28) Water pump | (31) Belt tensioner |
| (26) Coolant outlet connection | (29) Inlet connection for the coolant | (32) Alternator |

C4.4 Engine with Single Turbocharger

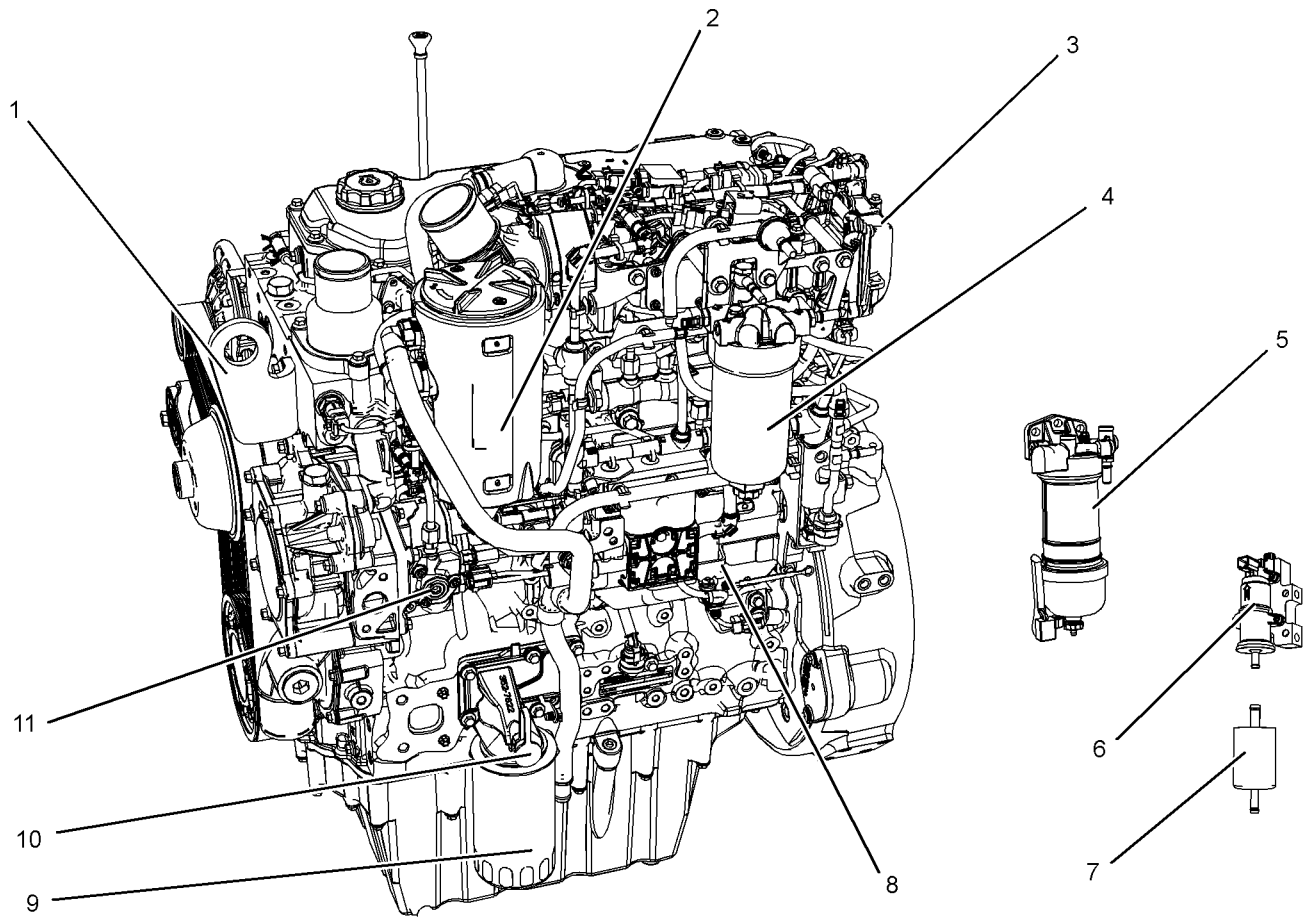

Illustration 4

g02407436

Typical example

- | | | |
|--------------------------------|-------------------------------------|--------------------------|
| (1) Front lifting eye | (5) Primary fuel filter | (9) Oil filter |
| (2) Crankcase breather | (6) Fuel priming pump | (10) Oil sampling valve |
| (3) NOx Reduction System (NRS) | (7) Fuel strainer | (11) Fuel injection pump |
| (4) Secondary fuel filter | (8) Electronic Control Module (ECM) | |

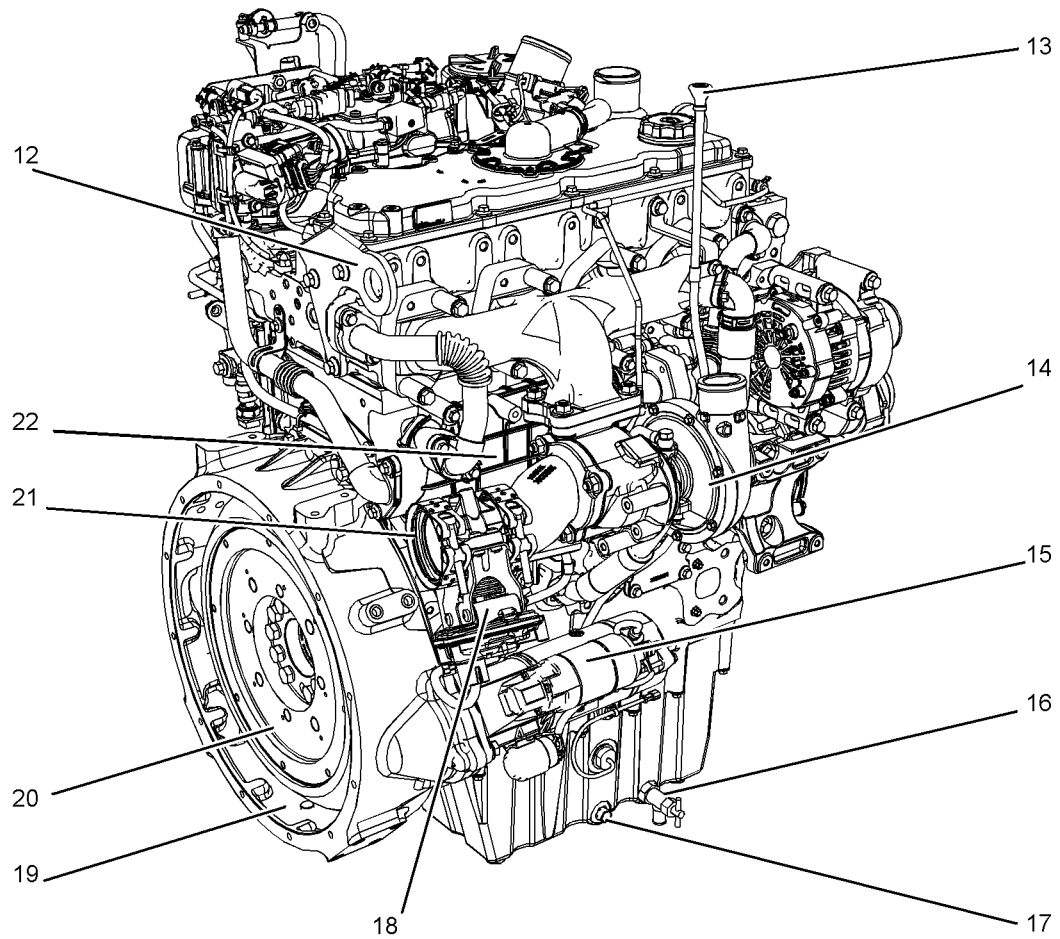

Illustration 5

g02407536

Typical example

- (12) Rear lifting eye
- (13) Oil gauge (dipstick)
- (14) Turbocharger
- (15) Starting motor

- (16) Oil drain valve
- (17) Oil drain plug
- (18) Back pressure valve
- (19) Flywheel housing

- (20) Flywheel
- (21) Exhaust outlet
- (22) Exhaust gas cooler (NRS)

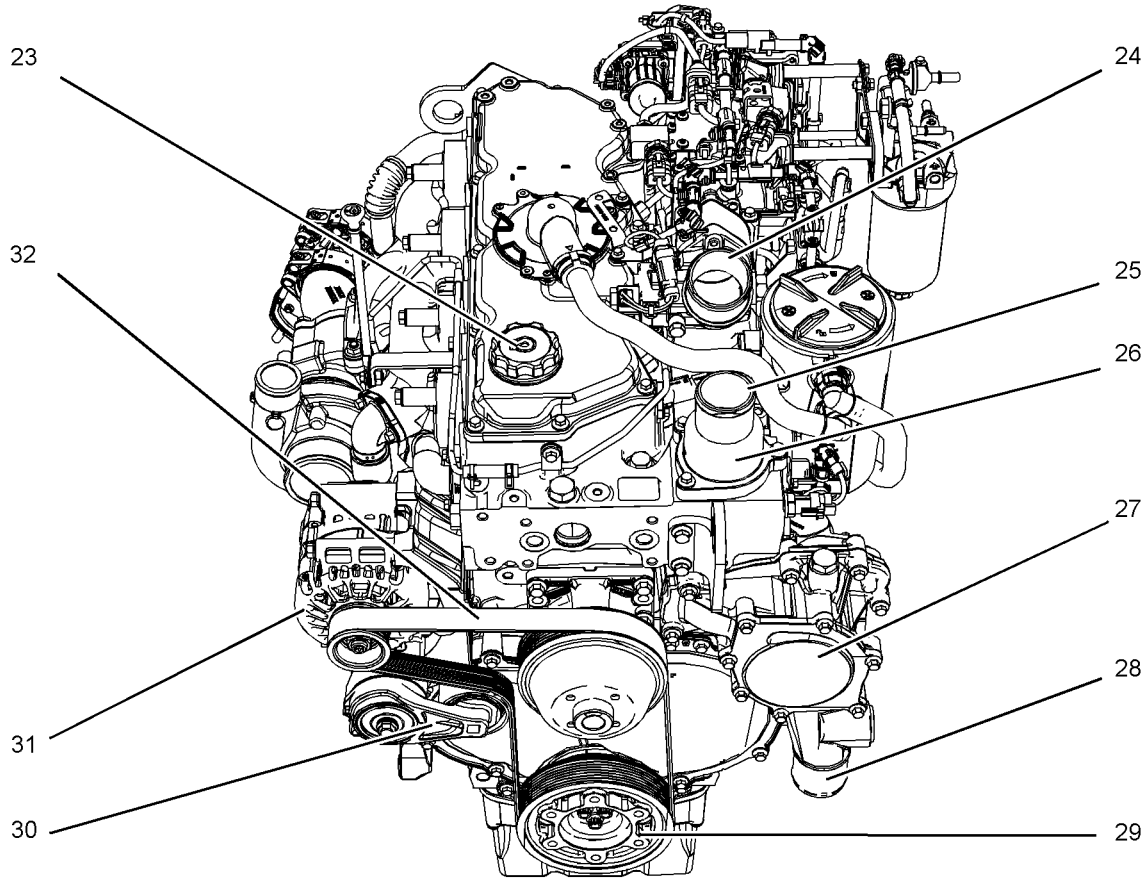

Illustration 6

g02407537

Typical example

- (23) Oil filler
- (24) Connection for air inlet
- (25) Outlet connection for the coolant
- (26) Water temperature regulator housing

- (27) Water pump
- (28) Inlet connection for the coolant
- (29) Crankshaft pulley
- (30) Belt tensioner

- (31) Alternator
- (32) Belt

Engine Operation

i04135810

Basic Engine

SMCS Code: 1200

Introduction

The eight major mechanical components of the basic engine are the following parts:

- Cylinder block
- Cylinder head
- Pistons

- Connecting rods
- Crankshaft
- Crankshaft pulley
- Timing gear case and gears
- Camshaft

Cylinder Block

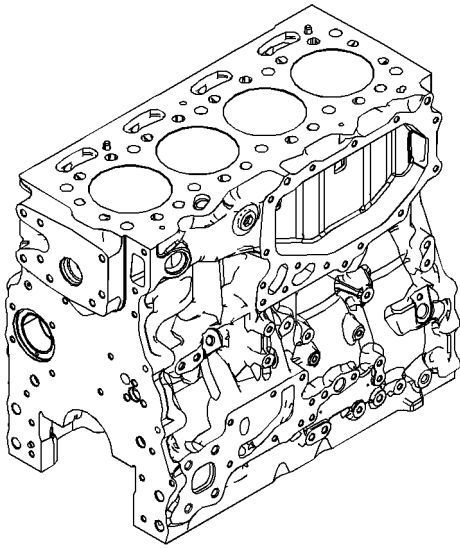

Illustration 7

g02149272

Typical example

The cast iron cylinder block for the four cylinder engine has four cylinders which are arranged in-line. The cylinder block is made of cast iron. The cylinder block provides support for the full length of the cylinder bores. The cylinder bores are machined into the block.

The cylinders are honed to a specially controlled finish in order to ensure long life and low oil consumption.

The cylinder block has five main bearings which support the crankshaft. Thrust washers are installed on both sides of number 3 main bearing in order to control the end play of the crankshaft. The thrust washers can only be installed one way.

Passages supply the lubrication for the crankshaft bearings. These passages are machined into the cylinder block.

Cooling passages are cast into the cylinder block in order to allow the circulation of coolant.

The cylinder block has a bush that is installed for the front camshaft journal. The other camshaft journals run directly in the cylinder block.

The engine has a cooling jet that is installed in the cylinder block for each cylinder. The piston cooling jet sprays lubricating oil onto the inner surface of the piston in order to cool the piston.

A Multi-Layered Steel (MLS) cylinder head gasket is used between the engine block and the cylinder head in order to seal combustion gases, water, and oil.

Cylinder Head

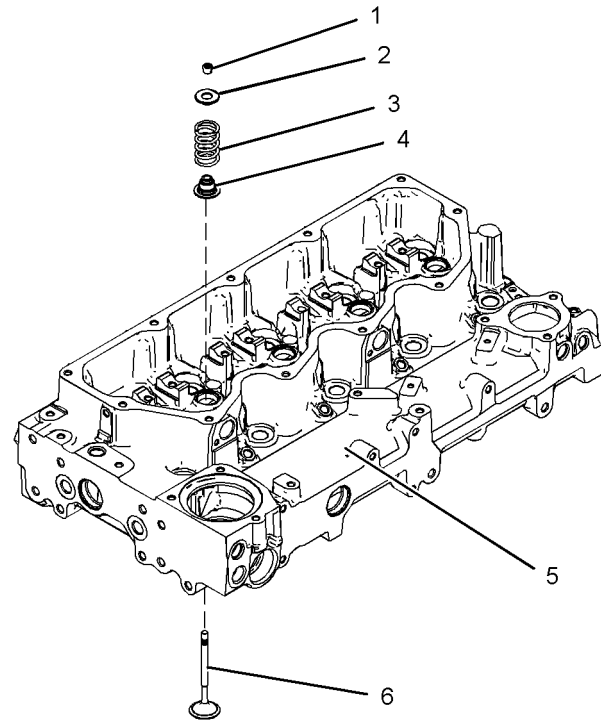

Illustration 8

g02466936

Typical example

- (1) Valve keepers
- (2) Valve spring retainer
- (3) Valve spring

The engine has a cast iron cylinder head (5). The inlet manifold is integral within the cylinder head. There are two inlet valves and two exhaust valves for each cylinder. Each pair of valves (6) are connected by a valve bridge that is controlled by a pushrod valve system. The ports for the inlet valves are on the left side of the cylinder head. The ports for the exhaust valves are on the right side of the cylinder head. The valve stems move in valve guides that are pressed into the cylinder head. There is a renewable stem seal (4) that fits over the top of the valve guide. The valve seats are replaceable.

Pistons, Rings, and Connecting rods

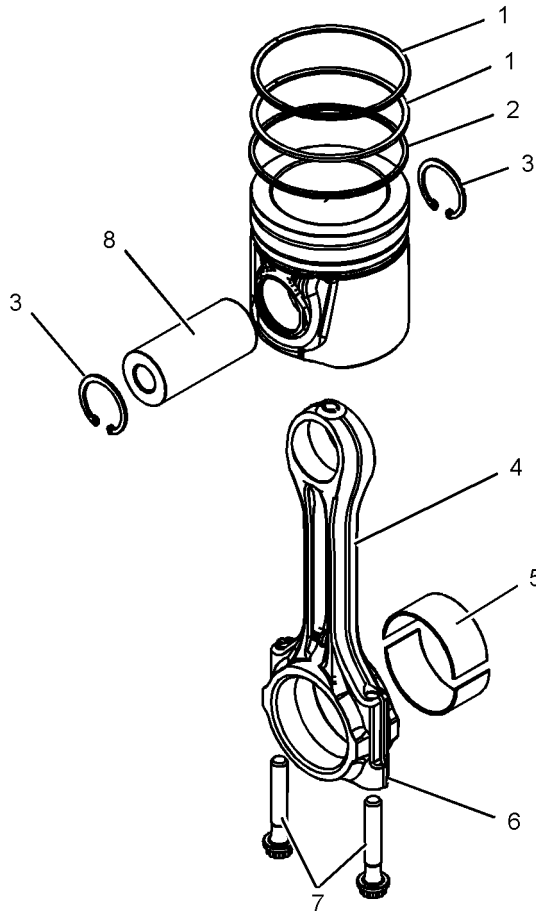

Illustration 9

g02466938

Typical example

The pistons (9) have a Quiescent combustion chamber in the top of the piston in order to provide an efficient mix of fuel and air. The piston pin (8) is off-center in order to reduce the noise level. The position pin (8) is retained in the correct position by two circlips (3).

The pistons have two compression rings (1) and an oil control ring (2). The groove for the top ring has a hard metal insert in order to reduce wear of the groove. The piston skirt has a low friction coating in order to reduce the risk of seizure when the engine is new.

The correct piston height is important in order to ensure that the piston does not contact the cylinder head. The correct piston height also ensures the efficient combustion of fuel which is necessary in order to conform to requirements for emissions.

The connecting rods (4) are machined from forged steel. The connecting rods have bearing caps (6) that are fracture split. Two connecting rod bearings (5) are installed between the connecting rod (4) and the bearing cap (6). The bearing caps on fracture split connecting rods are retained with Torx bolts (7). Connecting rods with bearing caps that are fracture split have the following characteristics:

- The splitting produces an accurately matched surface on each side of the fracture for improved strength.
- The correct connecting rod must be installed with the correct bearing cap. Each connecting rod and bearing cap have a unique serial number. When a connecting rod is assembled the serial numbers for the connecting rod and bearing cap must match.

Crankshaft

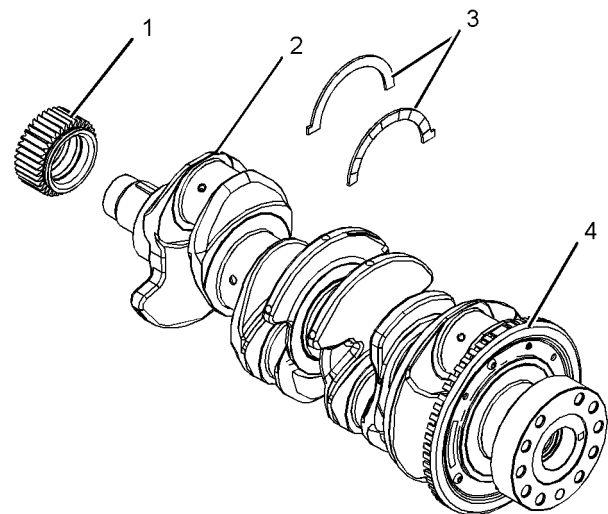

Illustration 10

g02155439

Typical example

- (1) Crankshaft gear
- (2) Crankshaft
- (3) Crankshaft thrust washers
- (4) Crankshaft timing ring

The crankshaft can be a spheroidal graphite iron casting or a steel forging.

The crankshaft has five main journals. Thrust washers are installed on both sides of number 3 main bearing in order to control the end play of the crankshaft.

The crankshaft changes the linear energy of the pistons and connecting rods into rotary torque in order to power external equipment.

A gear at the front of the crankshaft drives the timing gears. The crankshaft gear turns the idler gear which then turns the following gears:

- Camshaft gear
- Fuel injection pump and fuel transfer pump
- The idler gear is driven by the crankshaft gear which turns the gear of the lubricating oil pump.

Lip type seals are used on both the front of the crankshaft and the rear of the crankshaft.

A timing ring is installed to the crankshaft. The timing ring is used by the ECM in order to measure the engine speed and the engine position.

A ring gear for the balancer can be installed to the crankshaft. When a balancer is installed, the engine oil pump is an integral part of the balancer assembly. The ring gear for the balancer drives the balancer.

Gears and Timing Gear Case

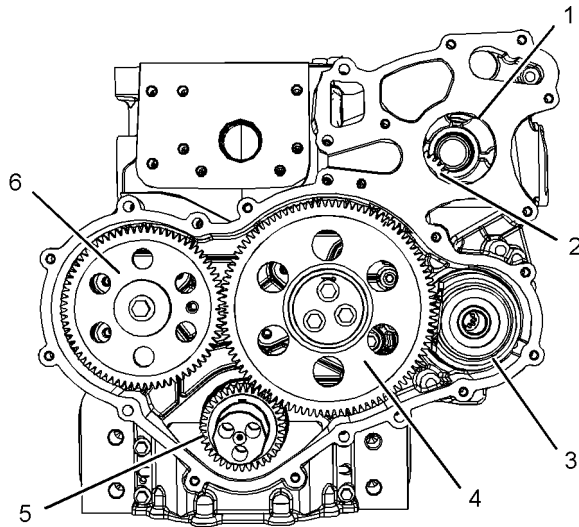

Illustration 11

g02212814

Typical example

- (1) Hole for the water pump gear
(3) Position of the accessory drive gear

The crankshaft oil seal is mounted in the cover of the timing case. The timing case cover is made from sound-deadened steel or cast iron.

The timing gears are made of steel.

The crankshaft gear (5) drives an upper idler gear (4) and a lower idler gear. The upper idler gear (4) drives the camshaft gear (6) and the fuel injection pump gear (2). The lower idler gear drives the oil pump. The water pump drive gear is driven by the fuel injection pump gear.

The camshaft rotates at half the engine speed. The fuel injection pump rotates at engine speed.

Camshaft

The engine has a single camshaft. The camshaft is made of cast iron. The camshaft lobes are chill hardened.

The camshaft is driven at the front end. As the camshaft turns, the camshaft lobes move the valve system components. The valve system components move the cylinder valves.

The camshaft gear must be timed to the crankshaft gear. The relationship between the lobes and the camshaft gear causes the valves in each cylinder to open at the correct time. The relationship between the lobes and the camshaft gear also causes the valves in each cylinder to close at the correct time.

i04302990

Air Inlet and Exhaust System (Single Turbocharger)

SMCS Code: 1050

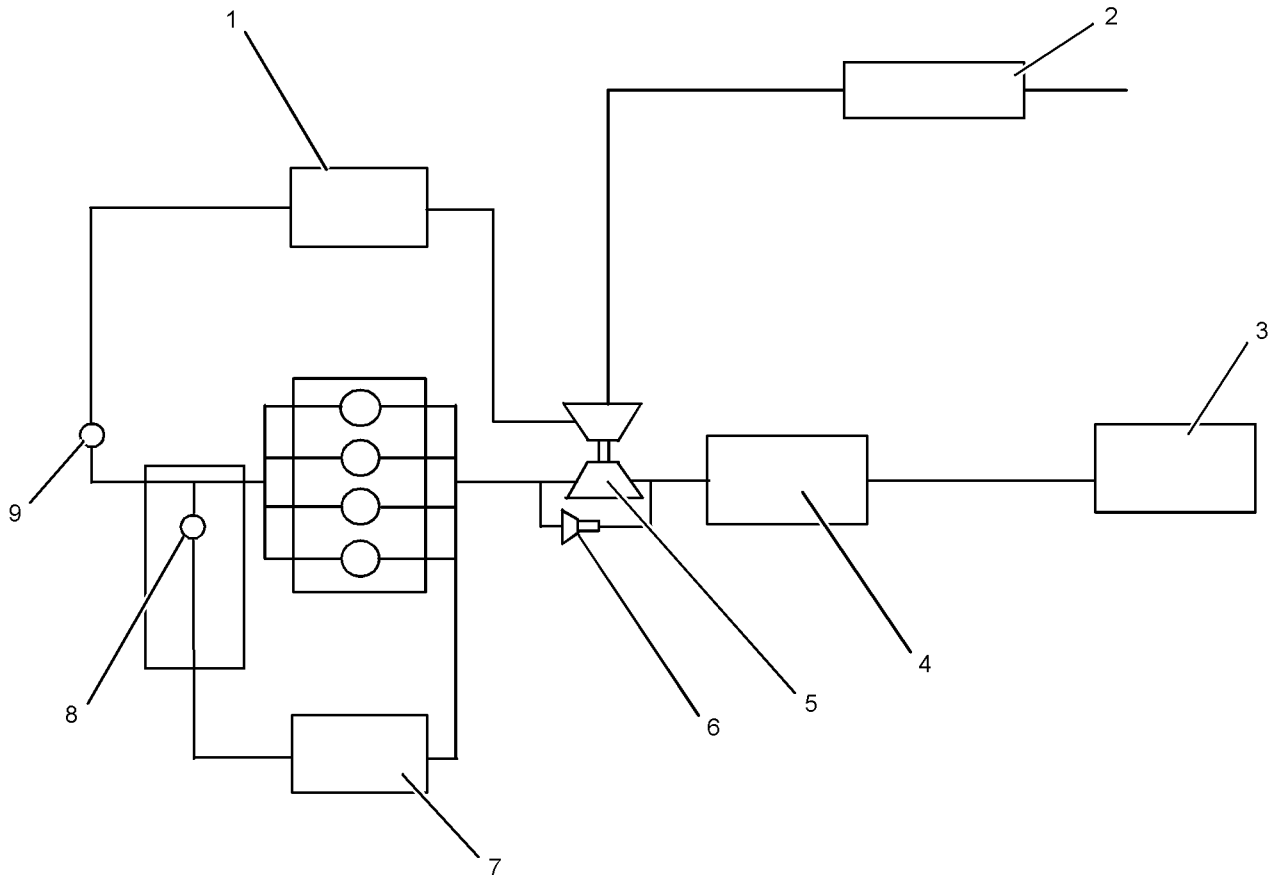

Illustration 12

g02469917

Air inlet and exhaust system

(1) Aftercooler core

(2) Air filter

(3) Diesel particulate filter

(4) Back pressure valve

(5) Turbocharger

(6) Wastegate actuator

(7) Exhaust cooler (NRS)

(8) Exhaust gas valve (NRS)

(9) Wastegate regulator

The components of the air inlet and exhaust system control the quality of air and the amount of air that is available for combustion. The air inlet and exhaust system consists of the following components:

- Air cleaner
- Exhaust cooler (NRS)
- Exhaust gas valve (NRS)
- Turbocharger
- Aftercooler
- Inlet manifold
- Cylinder head, injectors, and glow plugs
- Valves and valve system components
- Piston and cylinder
- Exhaust manifold
- Diesel oxidation catalyst
- Diesel particulate filter

Air is drawn in through the air cleaner into the air inlet of the turbocharger by the turbocharger compressor wheel. The air is compressed to a pressure of about 150 kPa (22 psi) and heated to about 120° C (248° F) before the air is forced to the aftercooler. As the air flows through the aftercooler the temperature of the compressed air lowers to about 55° C (131° F). Cooling of the inlet air assists the combustion efficiency of the engine. Increased combustion efficiency helps achieve the following benefits:

- Lower fuel consumption
- Increased power output
- Reduced NOx emission
- Reduced particulate emission

From the aftercooler, the air flows to the exhaust gas valve (NRS). A mixture of air and exhaust gas is then forced into the inlet manifold. Air flow from the inlet manifold to the cylinders is controlled by inlet valves. There are two inlet valves and two exhaust valves for each cylinder. The inlet valves open when the piston moves down on the intake stroke. When the inlet valves open, cooled compressed air from the inlet port is forced into the cylinder. The complete cycle consists of four strokes:

- Inlet
- Compression
- Power
- Exhaust

On the compression stroke, the piston moves back up the cylinder and the inlet valves close. The cool compressed air is compressed further. This additional compression generates more heat.

Note: If the cold starting system is operating, the glow plugs will also heat the air in the cylinder.

Just before the piston reaches the top center (TC) position, the ECM operates the electronic unit injector. Fuel is injected into the cylinder. The air/fuel mixture ignites. The ignition of the gases initiates the power stroke. Both the inlet and the exhaust valves are closed and the expanding gases force the piston downward toward the bottom center (BC) position.

From the BC position, the piston moves upward. This initiates the exhaust stroke. The exhaust valves open. The exhaust gases are forced through the open exhaust valves into the exhaust manifold.

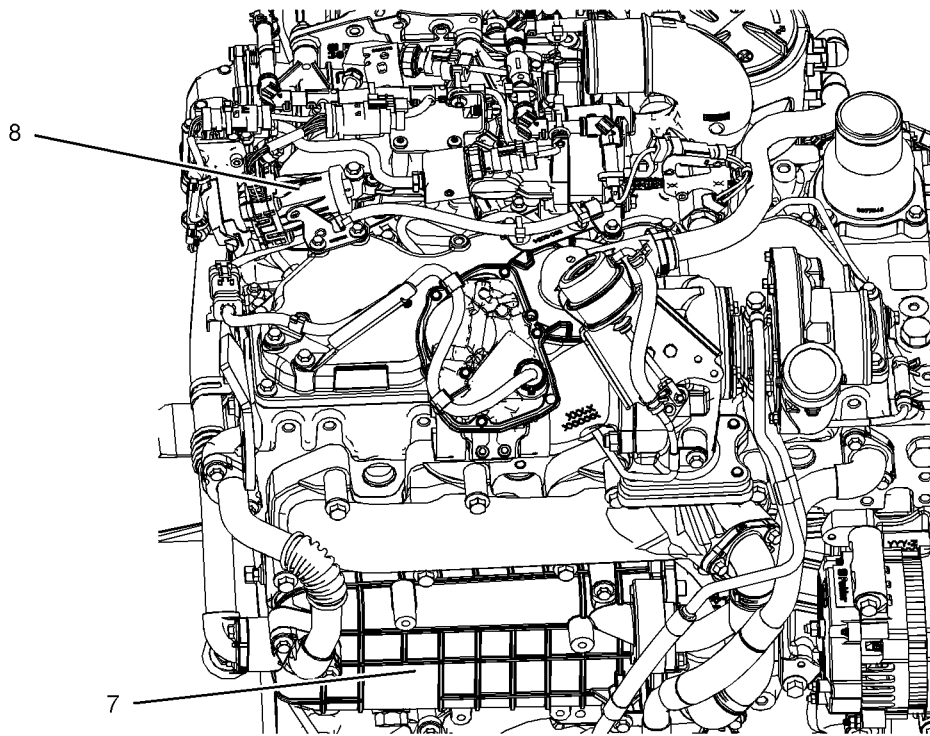

Illustration 13
Typical example

g02469919

The NOx Reduction System (NRS) operates with the transfer of the hot exhaust gas from the exhaust manifold to the exhaust cooler (7). The hot exhaust gas is cooled in the exhaust cooler. The now cooled exhaust gas passes through the assembly of exhaust gas valve.

The reed valves that are located in the exhaust gas valve (NRS) has one main function. The one main function is to prevent the reverse flow of charge air from the inlet side of the engine to the exhaust side of the engine.

As the electronically controlled valve (8) starts to open the flow of cooled exhaust gas from the exhaust cooler (7) mixes with the air flow from the charge air aftercooler. The mixing of the cooled exhaust gas and the air flow from the charge air aftercooler reduces the oxygen content of the gas mixture. This results in a lower combustion temperature, so decreases the production of NOx.

As the demand for more cooled exhaust gas increases the electronically controlled valve opens further. The further opening of the valve increases the flow of cooled exhaust gas from the exhaust cooler. As the demand for cooled exhaust gas decreases, the electronically controlled valve closes. This decreases the flow of cooled exhaust gas from the exhaust cooler.

Exhaust gases from the exhaust manifold enter the inlet of the turbocharger in order to turn the turbocharger turbine wheel. The turbine wheel is connected to a shaft that rotates. The exhaust gases pass from the turbocharger through the following components: exhaust outlet, back pressure valve, Diesel Oxidation Catalyst (DOC), Diesel Particulate Filter (DPF), and exhaust pipe.

Turbocharger

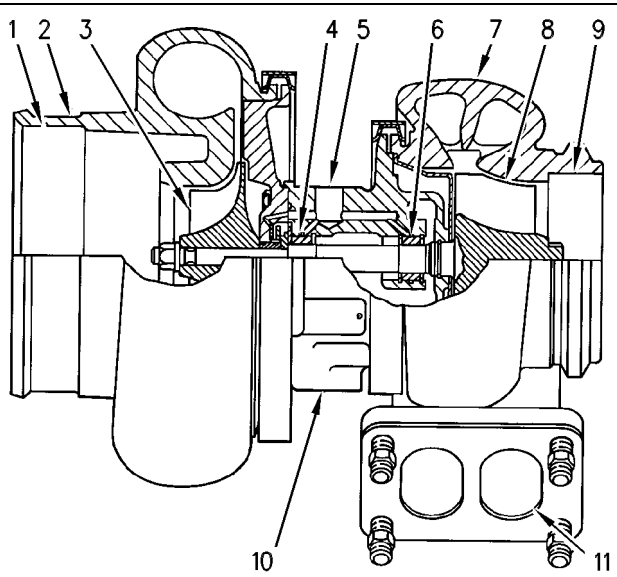

Illustration 14 g00302786

Typical example of a cross section of a turbocharger

- (1) Air intake
- (2) Compressor housing
- (3) Compressor wheel
- (4) Bearing
- (5) Oil inlet port
- (6) Bearing
- (7) Turbine housing
- (8) Turbine wheel
- (9) Exhaust outlet
- (10) Oil outlet port
- (11) Exhaust inlet

The turbocharger is mounted on the outlet of the exhaust manifold. The exhaust gas from the exhaust manifold enters the exhaust inlet (11) and passes through the turbine housing (7) of the turbocharger. Energy from the exhaust gas causes the turbine wheel (8) to rotate. The turbine wheel (8) is connected by a shaft to the compressor wheel (3).

As the turbine wheel rotates, the compressor wheel is rotated. The rotation of the compressor wheel causes the intake air to be pressurized through the compressor housing (2) of the turbocharger.

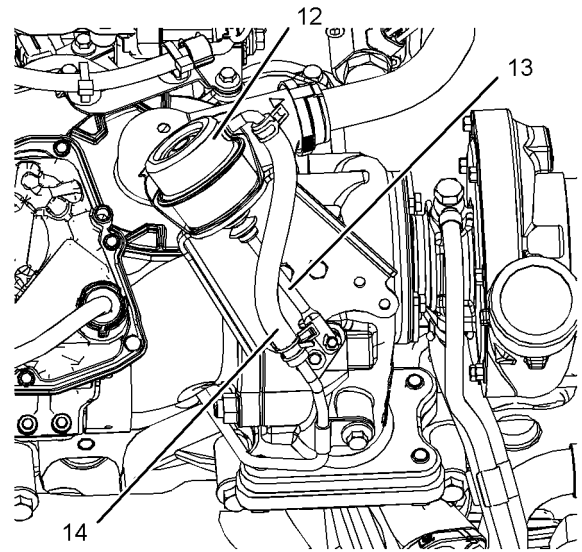

Illustration 15 g02469997

Typical example

- (12) Wastegate actuator
- (13) Actuating lever
- (14) Line (boost pressure)

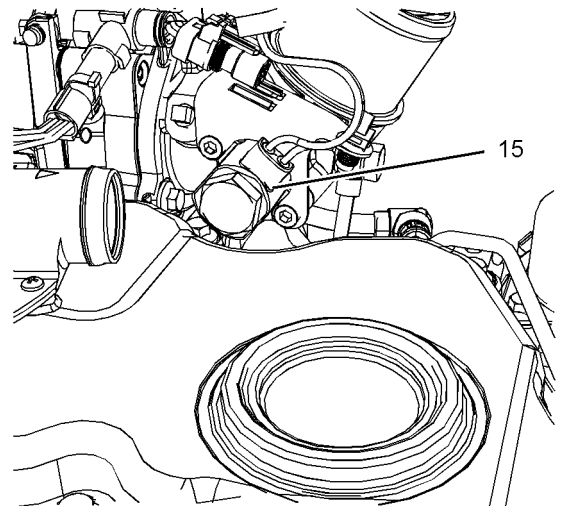

Illustration 16 g02151895

Typical example

- (15) Wastegate regulator

When the load on the engine increases, more fuel is injected into the cylinders. The combustion of this additional fuel produces more exhaust gases. The additional exhaust gases cause the turbine and the compressor wheels of the turbocharger to turn faster. As the compressor wheel turns faster, air is compressed to a higher pressure and more air is forced into the cylinders. The increased flow of air into the cylinders allows the fuel to be burnt with greater efficiency. This produces more power.

A wastegate is installed on the turbine housing of the turbocharger. The wastegate is a valve that allows exhaust gas to bypass the turbine wheel of the turbocharger. The operation of the wastegate is dependent on the pressurized air (boost pressure) from the turbocharger compressor. The boost pressure acts on a diaphragm that is spring loaded in the wastegate actuator which varies the amount of exhaust gas that flows into the turbine.

The wastegate regulator (15) is controlled by the engine Electronic Control Module (ECM). The ECM uses inputs from a number of engine sensors to determine the optimum boost pressure. This will achieve the best exhaust emissions and fuel consumption at any given engine operating condition. The ECM controls the wastegate regulator, that regulates the boost pressure to the wastegate actuator.

When higher boost pressure is needed for the engine performance, a signal is sent from the ECM to the wastegate regulator. The wastegate regulator reduces the pressure in the air inlet pipe (14) that acts upon the diaphragm within the wastegate actuator (12).

The spring within the wastegate actuator (12) forces the wastegate valve that is within the turbine housing to close via the actuating rod and lever. When the wastegate valve is closed, more exhaust gas is able to pass over the turbine wheel. This results in an increase in turbocharger speed and boost pressure generation.

When lower boost pressure is needed for the engine performance, a signal is sent from the ECM to the wastegate regulator. This causes high pressure in the air inlet pipe (14) to act on the diaphragm within the wastegate actuator (12). The actuating rod (13) acts upon the actuating lever to open the valve in the wastegate. When the valve in the wastegate is opened, more exhaust gas from the engine is able to bypass the turbine wheel. The exhaust gases bypass the turbine wheel results in a decrease in the speed of the turbocharger.

The shaft that connects the turbine to the compressor wheel rotates in bearings (4) and (6). The bearings require oil under pressure for lubrication and cooling. The oil that flows to the lubricating oil inlet port (5) passes through the center of the turbocharger which retains the bearings. The oil exits the turbocharger from the lubricating oil outlet port (10) and returns to the oil pan.

Crankcase Breather

The engine crankcase breather is a filtered system. The crankcase breather system consists of two main elements, a primary separator in the valve mechanism cover and a filtered canister that is mounted on the cylinder head. The gases exit the engine through the valve mechanism cover. The gases then pass through the primary separator. The primary separator removes most of the liquid oil from the gas. The liquid oil is then returned to the engine.

The gas then passes through the filter element before exiting to atmosphere in an open breather system or back to the induction system in a closed breather system via the breather vent pipe.

Any liquid oil that is captured by the filter drains from the bottom of the canister. The liquid oil is returned by the drain pipe that runs from the bottom of the canister back to the crankcase. A valve connects the drain pipe to the crankcase. This valve prevents the bypass of gas past the filter and oil from passing up the drain pipe.

A pressure relief valve is located in the rear of the canister in the integral mounting bracket. Under normal operation of the engine, this valve will not operate. If part of the system becomes blocked the valve will open at a pressure of 8.5 kPa (1.2 psi). The open valve will allow gas to bypass the filter and the pipes for venting.

The filter element can be accessed by removing the top cap of the canister. Refer to Operation and Maintenance Manual, "Engine Crankcase Breather Element - Replace" for the correct procedure.

NOTICE

The crankcase breather gases are part of the engines measured emissions output. Any tampering with the breather system could invalidate the engines emissions compliance.

Valve System Components

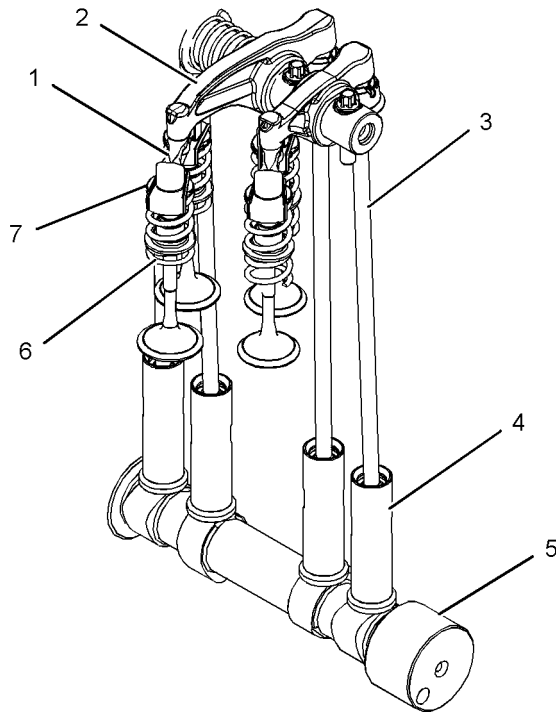

Illustration 17

g01924293

Valve system components

- (1) Bridge
- (2) Rocker arm
- (3) Pushrod
- (4) Lifter
- (5) Camshaft
- (6) Spring
- (7) Valve

The valve system components control the flow of inlet air into the cylinders during engine operation. The valve system components also control the flow of exhaust gases out of the cylinders during engine operation.

The crankshaft gear drives the camshaft gear through an idler gear. The camshaft (5) must be timed to the crankshaft in order to get the correct relation between the piston movement and the valve movement.

The camshaft (5) has two camshaft lobes for each cylinder. The lobes operate either a pair of inlet valves or a pair of exhaust valves. As the camshaft turns, lobes on the camshaft cause the lifter (4) to move the pushrod (3) up and down.

The lifter (4) incorporates a hydraulic lash adjuster which removes valve lash from the valve mechanism. The lifter (4) uses engine lubricating oil to compensate for wear of system components so that no service adjustment of valve lash is needed.

The engine lubricating oil enters the lifter (4) through a non-return valve. The engine lubricating oil increases the length of the lifter (4) until all valve lash is removed. If the engine is stationary for a prolonged period the valve springs will cause the lifter (4) to shorten so that when the engine is started engine valve lash is present for the first few seconds.

After cranking restores oil pressure the lifter (4) increases in length and removes the valve lash. When load is removed from a lifter (4) during service work by the removal of the rocker shaft the lifter (4) increases in length to the maximum extent. Refer to Systems Operation, Testing and Adjusting, "Position the Valve Mechanism Before Maintenance Procedures" for the correct procedure.

During reassembly of the rocker shaft the engine must be put into a safe position to avoid engine damage. After load is imposed on the lifters by reassembling the rocker assembly, the engine must be left in safe position for a safe period until the lifters have reduced to the correct length. Refer to Disassembly and Assembly, "Rocker Shaft and Pushrod - Install" for the correct procedure.

Upward movement of the pushrod against rocker arm (2) results in a downward movement that acts on the valve bridge (1). This action opens a pair of valves (7) which compresses the valve springs (6). When the camshaft (5) has rotated to the peak of the lobe, the valves are fully open. When the camshaft (5) rotates further, the two valve springs (6) under compression start to expand. The valve stems are under tension of the springs. The stems are pushed upward in order to maintain contact with the valve bridge (1). The continued rotation of the camshaft causes the rocker arm (2), the pushrods (3) and the lifters (4) to move downward until the lifter reaches the bottom of the lobe. The valves (7) are now closed. The cycle is repeated for all the valves on each cylinder.

i04302992

Air Inlet and Exhaust System (Series Turbochargers)

SMCS Code: 1050

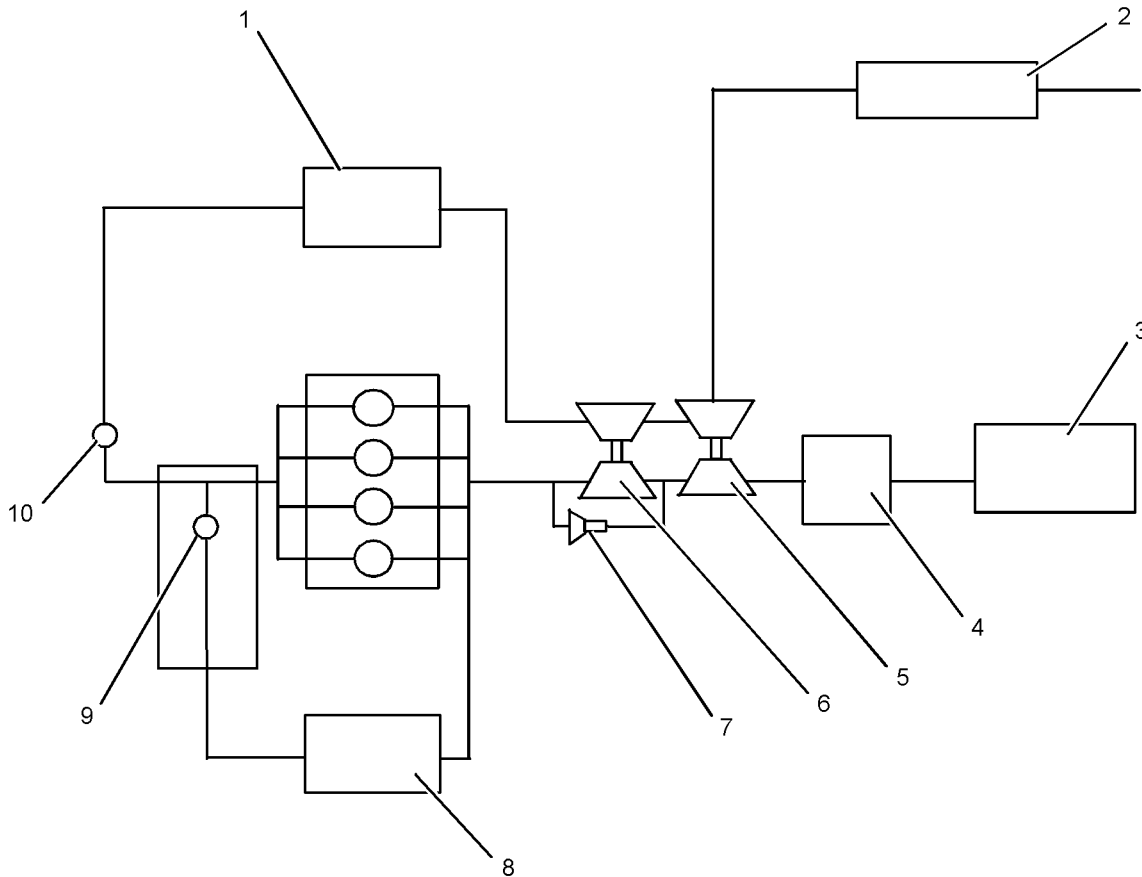

Illustration 18

g02467317

Air inlet and exhaust system

- | | | |
|-------------------------------|--------------------------------|-----------------------------|
| (1) Aftercooler core | (5) Low-pressure turbocharger | (9) Exhaust gas valve (NRS) |
| (2) Air filter | (6) High-pressure turbocharger | (10) Wastegate regulator |
| (3) Diesel particulate filter | (7) Wastegate actuator | |
| (4) Back pressure valve | (8) Exhaust cooler (NRS) | |

The components of the air inlet and exhaust system control the quality of air and the amount of air that is available for combustion. The air inlet and exhaust system consists of the following components:

- Air cleaner
- Exhaust cooler (NRS)
- Exhaust gas valve (NRS)
- Turbochargers
- Aftercooler
- Inlet manifold
- Cylinder head, injectors, and glow plugs
- Valves and valve system components
- Piston and cylinder
- Exhaust manifold
- Diesel oxidation catalyst
- Diesel particulate filter

Air is drawn in through the air cleaner into the air inlet of the low-pressure turbocharger by the low-pressure turbocharger compressor wheel. The air is compressed to a pressure of about 75 kPa (11 psi) and heated to about 120° C (248° F). From the low-pressure turbocharger, the air passes to the high-pressure turbocharger. The air is compressed to a pressure of about 220 kPa (32 psi) and heated to about 240° C (464° F) before the air is forced to the aftercooler. The air flows through the aftercooler. The temperature of the compressed air lowers to about 55° C (131° F). Cooling of the inlet air assists the combustion efficiency of the engine. Increased combustion efficiency helps achieve the following benefits:

- Lower fuel consumption
- Increased power output
- Reduced NOx emission
- Reduced particulate emission

From the aftercooler, the air flows to the exhaust gas valve (NRS). A mixture of air and exhaust gas is then forced into the inlet manifold. Air flow from the inlet manifold to the cylinders is controlled by inlet valves. There are two inlet valves and two exhaust valves for each cylinder. The inlet valves open when the piston moves down on the intake stroke. When the inlet valves open, cooled compressed air from the inlet port is forced into the cylinder. The complete cycle consists of four strokes:

- Inlet
- Compression
- Power
- Exhaust

On the compression stroke, the piston moves back up the cylinder and the inlet valves close. The cool compressed air is compressed further. This additional compression generates more heat.

Note: If the cold starting system is operating, the glow plugs will also heat the air in the cylinder.

Just before the piston reaches the top center (TC) position, the ECM operates the electronic unit injector. Fuel is injected into the cylinder. The air/fuel mixture ignites. The ignition of the gases initiates the power stroke. Both the inlet and the exhaust valves are closed and the expanding gases force the piston downward toward the bottom center (BC) position.

From the BC position, the piston moves upward. The piston moving upward initiates the exhaust stroke. The exhaust valves open. The exhaust gases are forced through the open exhaust valves into the exhaust manifold.

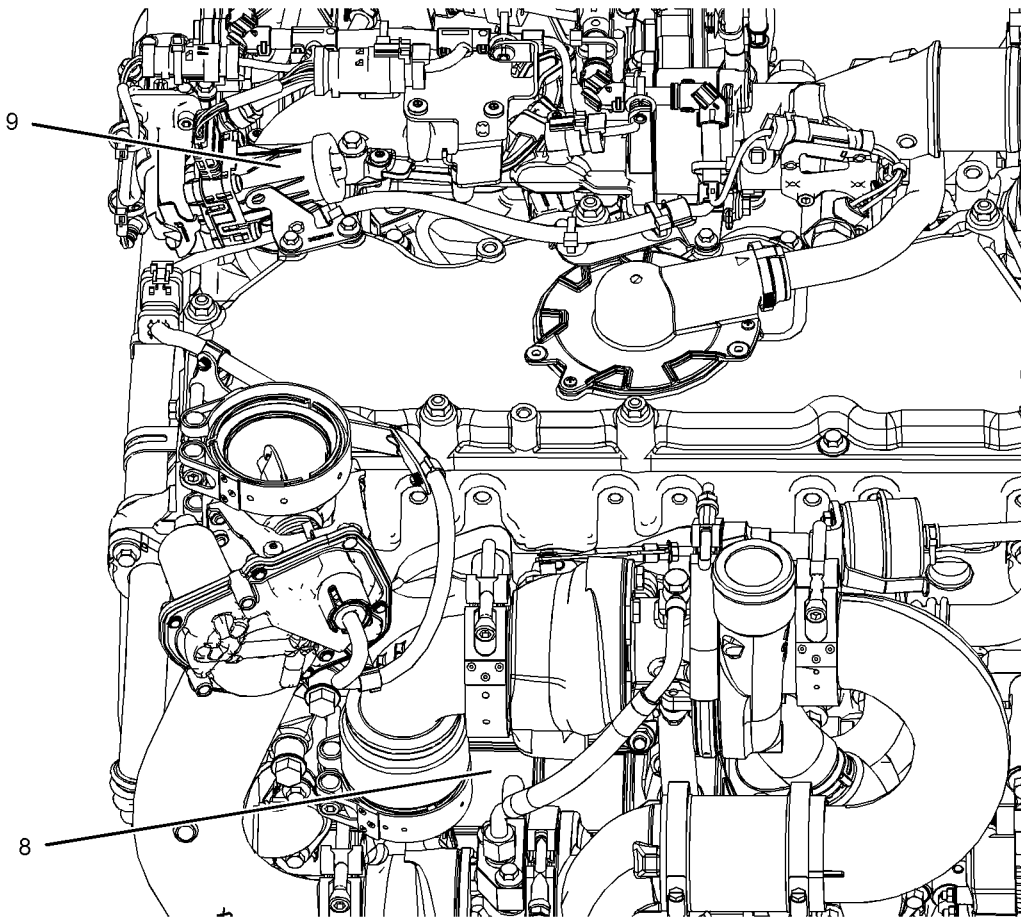

Illustration 19
Typical example

g02467360

The NOx Reduction System (NRS) operates with the transfer of the hot exhaust gas from the exhaust manifold to the exhaust cooler (8). The hot exhaust gas is cooled in the exhaust cooler (8). The now cooled exhaust gas passes through the assembly of the exhaust gas valve.

The reed valves that are located in the exhaust gas valve (NRS) has one main function. The one main function is to prevent the reverse flow of charge air from the inlet side of the engine to the exhaust side of the engine.

As the electronically controlled valve (9) starts to open the flow of cooled exhaust gas from the exhaust cooler (8) mixes with the air flow from the charge air aftercooler. The mixing of the cooled exhaust gas and the air flow from the charge air aftercooler reduces the oxygen content of the gas mixture. This results in a lower combustion temperature, so decreases the production of NOx.

As the demand for more cooled exhaust gas increases the electronically controlled valve opens further. The further opening of the valve increases the flow of cooled exhaust gas from the exhaust cooler. As the demand for cooled exhaust gas decreases, the electronically controlled valve closes. This decreases the flow of cooled exhaust gas from the exhaust cooler.

Exhaust gases from the exhaust manifold enter the inlet of the high-pressure turbocharger in order to turn the high-pressure turbocharger turbine wheel. The turbine wheel is connected to a shaft that rotates. The exhaust gases travel from the high-pressure turbocharger. The exhaust gases then travel through the duct on the turbine side into the turbine inlet of the low-pressure turbocharger in order to power the low-pressure turbocharger. The exhaust gases pass from the low-pressure turbocharger through the following components: exhaust outlet, back pressure valve, Diesel Oxidation Catalyst (DOC), Diesel Particulate Filter (DPF), and exhaust pipe.

Turbochargers

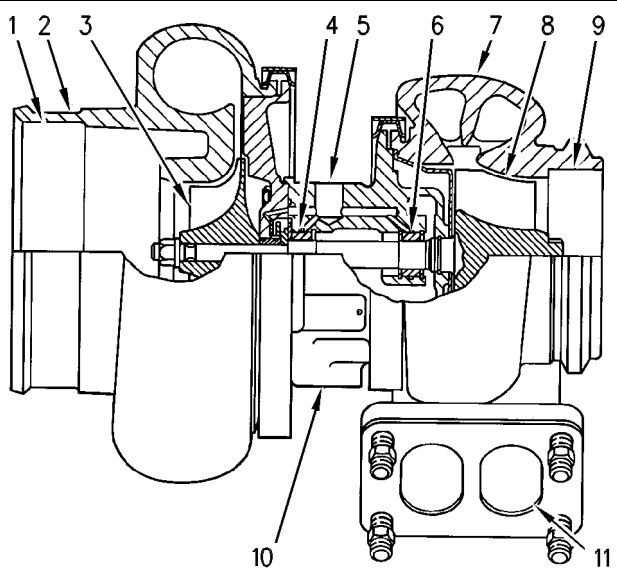

Illustration 20 g00302786

Typical example of a cross section of a turbocharger

- (1) Air intake
- (2) Compressor housing
- (3) Compressor wheel
- (4) Bearing
- (5) Oil inlet port
- (6) Bearing
- (7) Turbine housing
- (8) Turbine wheel
- (9) Exhaust outlet
- (10) Oil outlet port
- (11) Exhaust inlet

The high-pressure turbocharger is mounted on the outlet of the exhaust manifold. The low-pressure turbocharger is mounted on the side of the cylinder block. The exhaust gas from the exhaust manifold enters the exhaust inlet (11) and passes through the turbine housing (7) of the turbocharger. Energy from the exhaust gas causes the turbine wheel (8) to rotate. The turbine wheel is connected by a shaft to the compressor wheel (3).

As the turbine wheel rotates, the compressor wheel is rotated. This causes the intake air to be pressurized through the compressor housing (2) of the turbocharger.

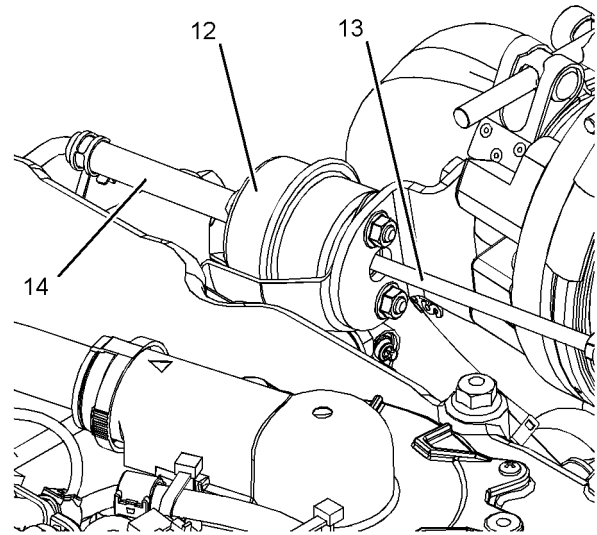

Illustration 21 g02467380

Typical example

- (12) Wastegate actuator
- (13) Actuating lever
- (14) Line (boost pressure)

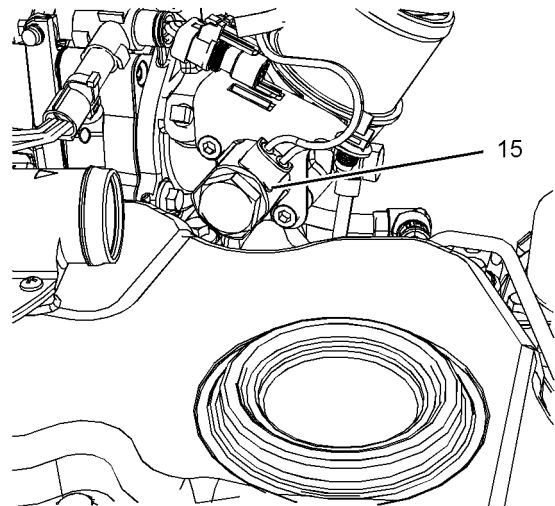

Illustration 22 g02151895

Typical example

- (15) Wastegate regulator

When the load on the engine increases, more fuel is injected into the cylinders. The combustion of this additional fuel produces more exhaust gases. The additional exhaust gases cause the turbine and the compressor wheels of the turbocharger to turn faster. As the compressor wheel turns faster, air is compressed to a higher pressure and more air is forced into the cylinders. The increased flow of air into the cylinders allows the fuel to be burnt with greater efficiency. This produces more power.

A wastegate is installed on the compressor side of the turbocharger. The wastegate is a valve that allows exhaust gas to bypass the turbine wheel of the turbocharger. The operation of the wastegate is dependent on the pressurized air (boost pressure) from the turbocharger compressor. The boost pressure acts on a diaphragm that is spring loaded in the wastegate actuator which varies the amount of exhaust gas that flows into the turbine.

The wastegate regulator (15) is controlled by the engine Electronic Control Module (ECM). The ECM uses inputs from a number of engine sensors to determine the optimum boost pressure. This will achieve the best exhaust emissions and fuel consumption at any given engine operating condition. The ECM controls the wastegate regulator, that regulates the boost pressure to the wastegate actuator.

When higher boost pressure is needed for the engine performance, a signal is sent from the ECM to the wastegate regulator. The wastegate regulator reduces the pressure in the air inlet pipe (14) that acts upon the diaphragm within the wastegate actuator (13).

The spring within the wastegate actuator (13) forces the wastegate valve that is within the turbine housing to close via the actuating rod and lever. When the wastegate valve is closed, more exhaust gas is able to pass over the turbine wheel. This results in an increase in turbocharger speed and boost pressure generation.

When lower boost pressure is needed for the engine performance, a signal is sent from the ECM to the wastegate regulator. This causes high pressure in the air inlet pipe (14) to act on the diaphragm within the wastegate actuator (13). The actuating rod (12) acts upon the actuating lever to open the valve in the wastegate. When the valve in the wastegate is opened, more exhaust gas from the engine is able to bypass the turbine wheel. The exhaust gases bypass the turbine wheel results in a decrease in the speed of the turbocharger.

The shaft that connects the turbine to the compressor wheel rotates in bearings (4) and (6). The bearings require oil under pressure for lubrication and cooling. The oil that flows to the lubricating oil inlet port (5) passes through the center of the turbocharger which retains the bearings. The oil exits the turbocharger from the lubricating oil outlet port (10) and returns to the oil pan.

Crankcase Breather

The engine crankcase breather is a filtered system. The crankcase breather system consists of two main elements, a primary separator in the valve mechanism cover and a filtered canister that is mounted on the cylinder head. The gases exit the engine through the valve mechanism cover. The gases then pass through the primary separator. The primary separator removes most of the liquid oil from the gas. The liquid oil is then returned to the engine.

The gas then passes through the filter element before exiting to atmosphere in an open breather system or back to the induction system in a closed breather system via the breather vent pipe.

Any liquid oil that is captured by the filter drains from the bottom of the canister. The liquid oil is returned by the drain pipe that runs from the bottom of the canister back to the crankcase. A valve connects the drain pipe to the crankcase. This valve prevents the bypass of gas past the filter and oil from passing up the drain pipe.

A pressure control valve is located in the top cap of the canister. This valve regulates the crankcase pressure on the closed breather system.

A pressure relief valve is located in the rear of the canister in the integral mounting bracket. Under normal operation of the engine, this valve will not operate. If part of the system becomes blocked the valve will open at a pressure of 8.5 kPa (1.2 psi). The open valve will allow gas to bypass the filter and the pipes for venting.

The filter element can be accessed by removing the top cap of the canister. Refer to Operation and Maintenance Manual, "Engine Crankcase Breather Element - Replace" for the correct procedure.

NOTICE

The crankcase breather gases are part of the engines measured emissions output. Any tampering with the breather system could invalidate the engines emissions compliance.

Valve System Components

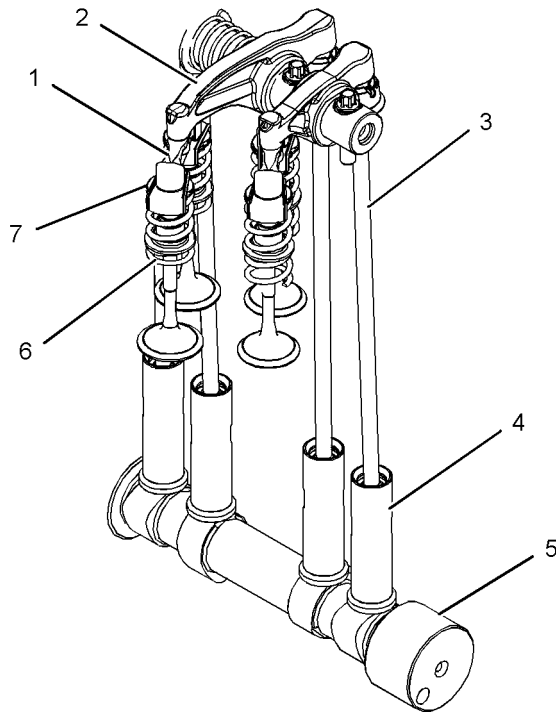

Illustration 23

g01924293

Valve system components

- (1) Bridge
- (2) Rocker arm
- (3) Pushrod
- (4) Lifter
- (5) Camshaft
- (6) Spring
- (7) Valve

The valve system components control the flow of inlet air into the cylinders during engine operation. The valve system components also control the flow of exhaust gases out of the cylinders during engine operation.

The crankshaft gear drives the camshaft gear through an idler gear. The camshaft (5) must be timed to the crankshaft in order to get the correct relation between the piston movement and the valve movement.

The camshaft (5) has two camshaft lobes for each cylinder. The lobes operate either a pair of inlet valves or a pair of exhaust valves. As the camshaft turns, lobes on the camshaft cause the lifter (4) to move the pushrod (3) up and down.

The lifter (4) incorporates a hydraulic lash adjuster which removes valve lash from the valve mechanism. The lifter (4) uses engine lubricating oil to compensate for wear of system components so that no service adjustment of valve lash is needed.

The engine lubricating oil enters the lifter (4) through a non-return valve. The engine lubricating oil increases the length of the lifter (4) until all valve lash is removed. If the engine is stationary for a prolonged period the valve springs will cause the lifter (4) to shorten so that when the engine is started engine valve lash is present for the first few seconds.

After cranking restores oil pressure the lifter (4) increases in length and removes the valve lash. When load is removed from a lifter (4) during service work by the removal of the rocker shaft the lifter (4) increases in length to the maximum extent. Refer to Systems Operation, Testing and Adjusting, "Position the Valve Mechanism Before Maintenance Procedures" for the correct procedure.

During reassembly of the rocker shaft the engine must be put into a safe position to avoid engine damage. After load is imposed on the lifters by reassembling the rocker assembly, the engine must be left in safe position for a safe period until the lifters have reduced to the correct length. Refer to Disassembly and Assembly, "Rocker Shaft and Pushrod - Install" for the correct procedure.

Upward movement of the pushrod against rocker arm (2) results in a downward movement that acts on the valve bridge (1). This action opens a pair of valves (7) which compresses the valve springs (6). When the camshaft (5) has rotated to the peak of the lobe, the valves are fully open. When the camshaft (5) rotates further, the two valve springs (6) under compression start to expand. The valve stems are under tension of the springs. The stems are pushed upward in order to maintain contact with the valve bridge (1). The continued rotation of the camshaft causes the rocker arm (2), the pushrods (3) and the lifters (4) to move downward until the lifter reaches the bottom of the lobe. The valves (7) are now closed. The cycle is repeated for all the valves on each cylinder.

i04121309

Clean Emissions Module

SMCS Code: 1062; 108B; 108E; 108F; 108M

To meet current emissions legislation requirements, a small amount of certain chemical compounds that are emitted by the engine must not be allowed to enter the atmosphere. The Clean Emissions Module (CEM) that is installed to the engine is designed to convert these chemical compounds into less harmful compounds.

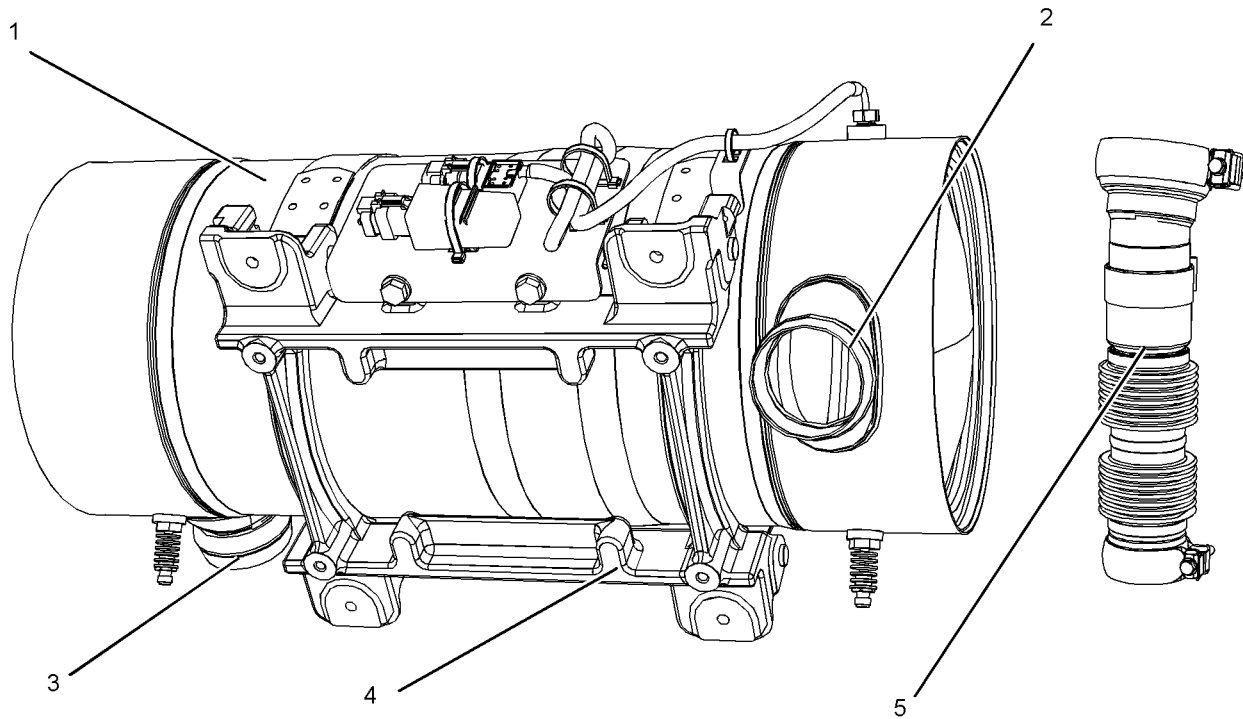

Illustration 24

g02384560

Typical example

(1) Clean emissions module (CEM)
(2) Inlet connection

(3) Outlet connection
(4) Mounting cradle

(5) Flexible exhaust pipe from engine to CEM

The Clean Emissions Module (CEM) for the engine consists of the following components.

- Diesel Oxidation Catalyst (DOC)
- Diesel Particulate Filter (DPF)

The Diesel Oxidation Catalyst (DOC) oxidizes the carbon monoxide and the hydrocarbons that are not burnt in the exhaust gas into carbon dioxide and water. The Diesel Oxidation Catalyst (DOC) is a through flow device that will continue to operate during all normal engine operating conditions.

The Diesel Particulate Filter (DPF) collects all particulate matter in the exhaust gas.

A flexible exhaust pipe connects the engine to the Clean Emissions Module (CEM). Refer to Disassembly and Assembly for the correct procedure to install the flexible exhaust pipe.

The solid particulate matter that is collected by the DPF consists of soot (carbon) from incomplete combustion of the fuel and inorganic ash from the combustion of any oil in the cylinder.

The rate of accumulation of ash is slow under normal engine operating conditions. The filter is designed to contain all the ash that is produced for the life of the engine.

The engine aftertreatment system is designed to oxidize the soot in the DPF at the same rate as the soot is produced by the engine. The oxidation of the soot will occur when the engine is operating under normal conditions. The soot in the DPF is constantly monitored. If the engine is operated in a way that produces more soot than the oxidized soot, the engine management system will automatically activate systems to raise the exhaust temperature. The raising of the exhaust temperature will ensure that more soot is oxidized than the soot that is produced by the engine. The oxidation of more soot returns the DPF to a reduced level of soot. The systems are then deactivated when the soot level has been reduced.

The engine ECM must know how much soot is in the DPF. Measurement of soot is accomplished through the following means:

- Radio frequency measurement across the DPF
- Calculated model based on developed engine out soot measurements

The Electronic Control Module (ECM) uses the soot measurement information to determine if the engine operating conditions need to be adjusted in order to oxidize the soot at an increased rate.

i04135351

Cooling System

SMCS Code: 1350

Introduction

The cooling system has the following components:

- Radiator
- Water pump
- Cylinder block
- Oil cooler
- Exhaust gas cooler (NRS)
- Cylinder head
- Water temperature regulator

Coolant Flow

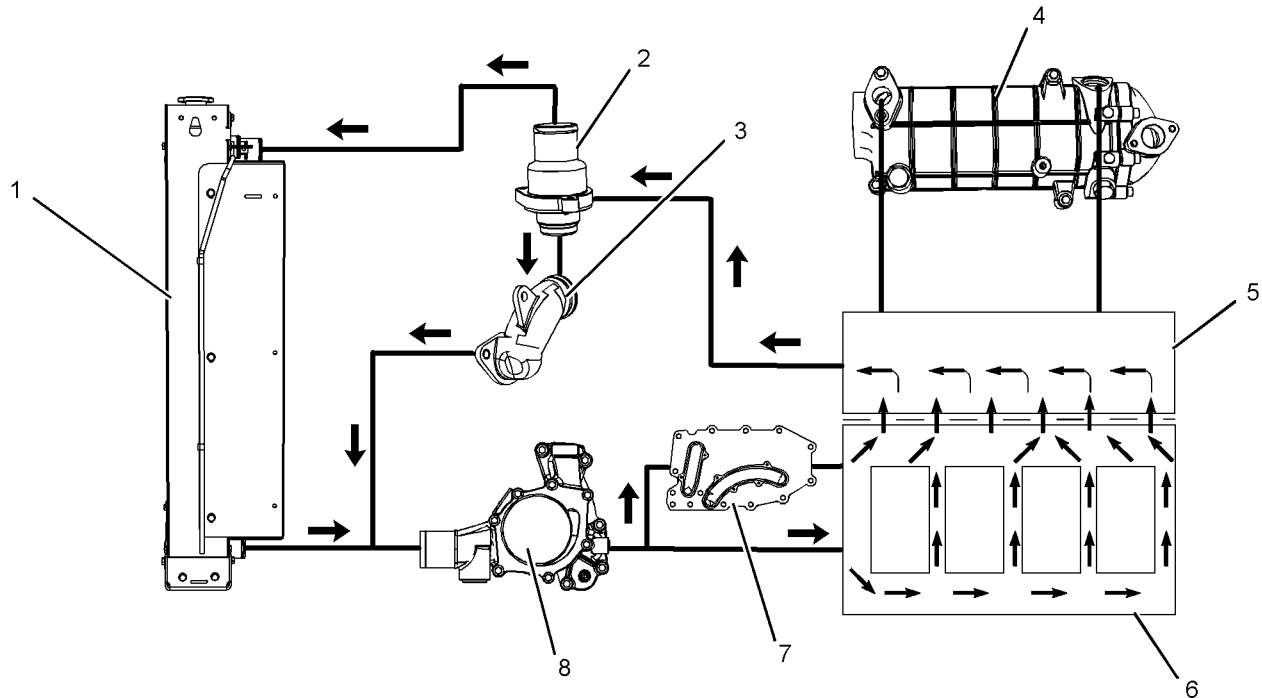

Illustration 25

g02332698

Typical example

- | | | |
|--|------------------------------|----------------|
| (1) Radiator | (4) Exhaust gas cooler (NRS) | (8) Water pump |
| (2) Water temperature regulator and housing | (5) Cylinder head | |
| (3) Bypass for the water temperature regulator | (6) Cylinder block | |
| | (7) Engine oil cooler | |

The coolant flows from the bottom of the radiator (1) to the centrifugal water pump (8). The water pump (8) is installed on the front of the timing case. The water pump (8) is driven by a gear. The gear of the fuel injection pump drives the water pump gear.

The water pump (8) contains a rotary seal that uses the engine coolant as a lubricating medium. This will ensure that an adequate sealing film is created. The sealing film is maintained in order to reduce heat generation. Heat that is generated by the rotating sealing faces under normal operating conditions causes a small flow of coolant to be emitted into a chamber. The water pump (8) pumps the coolant through a passage in the timing case to the front of the cylinder block (6).

The coolant enters a passage in the left side of the cylinder block (6). Some coolant enters the cylinder block. Some coolant passes over the element of the oil cooler (7). The coolant then enters the block (6). Coolant flows around the outside of the cylinders then flows from the cylinder block into the cylinder head (5).

Some coolant flows through a cavity in the front of the cylinder head (5). Some coolant is diverted into the exhaust gas cooler (4) by a coolant pipe in the rear of the cylinder head (5). The coolant then flows out of the exhaust gas cooler (4) to the cavity in the cylinder head (5).

The coolant then flows into the housing of the water temperature regulator (2). If the water temperature regulator (2) is closed, the coolant goes directly through a bypass (3) to the inlet side of the water pump. If the water temperature regulator is open, and the bypass is closed then the coolant flows to the top of the radiator (1).

i03909669

Lubrication System

SMCS Code: 1300

Lubricating oil from the oil pan flows through a strainer and a pipe to the suction side of the engine oil pump. Pressure for the lubrication system is supplied by the oil pump. The crankshaft gear drives a lower idler gear. The lower idler gear drives the oil pump gear. The pump has an inner rotor and an outer rotor. The axis of rotation of the rotors are off-center relative to each other. There is an interference fit between the inner rotor and the drive shaft.

If a balancer is installed, the engine oil pressure is provided by an integrated engine oil pump. The integrated engine oil pump is located in the balancer.

The inner rotor has five lobes which mesh with the six lobes of the outer rotor. When the pump rotates, the distance increases between the lobes of the outer rotor and the lobes of the inner rotor in order to create suction. When the distance decreases between the lobes, pressure is created.

The lubricating oil flows from the outlet side of the oil pump through a passage to the oil filter head. The oil then flows from the oil filter head through a passage to a plate type oil cooler. The oil cooler is located on the left side of the cylinder block.

From the oil cooler, the oil returns through a passage to the oil filter head. The oil then flows through a bypass valve that permits the lubrication system to function if the oil filter becomes blocked. Under normal conditions, the oil then flows to the oil filter.

The oil flows from the oil filter through a passage that is drilled across the cylinder block to the oil gallery. The oil gallery is drilled through the total length of the left side of the cylinder block. If the oil filter is on the right side of the engine, the oil flows through a passage that is drilled across the cylinder block to the pressure gallery.

Lubricating oil from the oil gallery flows through high-pressure passages to the main bearings of the crankshaft. Then, the oil flows through the passages in the crankshaft to the connecting rod bearing journals. The pistons and the cylinder bores are lubricated by the splash of oil and the oil mist.

Lubricating oil from the main bearings flows through passages in the cylinder block to the journals of the camshaft. Then, the oil flows from the front journal of the camshaft at a reduced pressure to the cylinder head. The oil then flows through the center of the rocker shaft to the rocker arm levers. The valve stems, the valve springs and the valve lifters are lubricated by the splash and the oil mist.

The hub of the idler gear is lubricated by oil from the oil gallery. The timing gears are lubricated by the splash from the oil.

An external line supplies oil to the high-pressure fuel pump. The oil then flows through a return line into the timing case and back to the oil pan.

Engines have piston cooling jets that are supplied with oil from the oil gallery. The piston cooling jets spray lubricating oil on the underside of the pistons in order to cool the pistons.

i03922889

Electrical System

SMCS Code: 1400; 1550; 1900

The electrical system is a negative ground system.

The charging circuit operates when the engine is running. The alternator in the charging circuit produces direct current for the electrical system.

Starting Motor

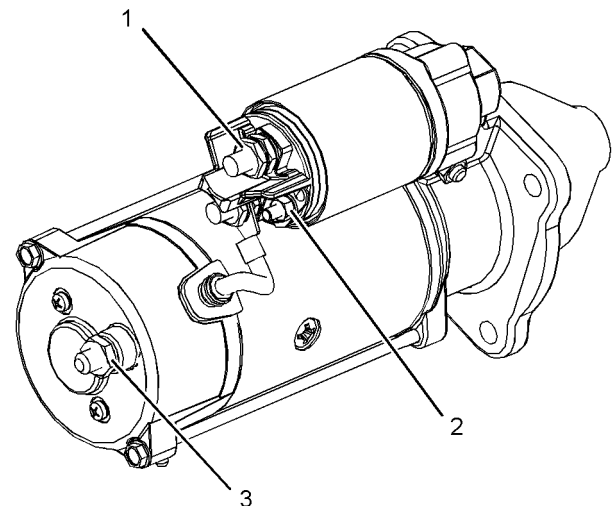

Illustration 26

g01964824

Typical example

12 V 4 kW Starting Motor

- (1) Terminal 30 for connection of the battery cable
- (2) Terminal 50 for connection of ignition switch
- (3) Terminal 31 for connection of the ground

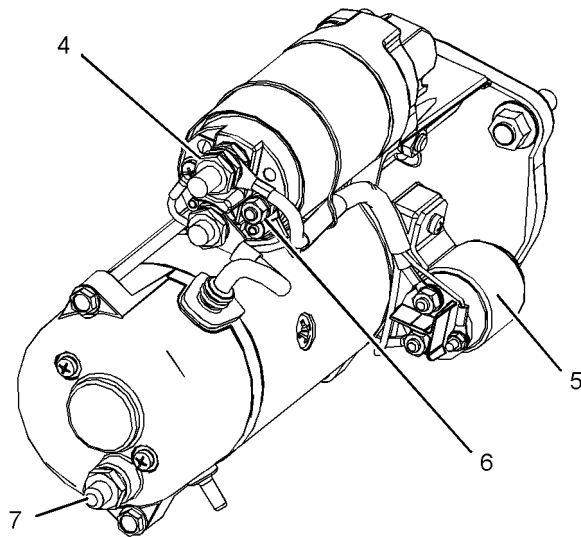

Illustration 27 g01964833

Typical example
24 V 5.5 kW Starting Motor

- (4) Terminal 30 for connection of the battery cable
- (5) Integrated Magnetic Switch (IMS)
- (6) Terminal 50 for connection of ignition switch
- (7) Terminal 31 for connection of the ground

The starting motor turns the engine via a gear on the engine flywheel. The starting motor speed must be high enough in order to initiate a sustained operation of the fuel ignition in the cylinders.

The starting motor consists of the main armature and a solenoid. The solenoid is a relay with two windings Pull-In (PI) and Hold-In (HI). Upon activation of ignition switch, both windings move the iron core by electromagnets. The linkage from the iron core acts to move the pinion toward the flywheel ring gear for engagement. Upon complete engagement, the solenoid completes the high current circuit that supplies electric power to the main armature in order to provide rotation. During cranking of the engine, only the Hold-In (HI) winding is active.

The ignition switch is deactivated once the desired engine speed has been achieved. The circuit is disconnected. The armature will stop rotating. Return springs that are located on the shafts and the solenoid will disengage the pinion from flywheel ring gear back to the rest position.

The armature of the starting motor and the mechanical transmissions may be damaged if the increases in the speed of the engine are greater than the pinion of the starting motor. Damage may occur when the engine is started or after the engine is started. An overrunning clutch prevents damage to the armature of the starting motor and mechanical transmissions.

Certain higher powered starting motors are designed with an Integrated Magnetic Switch (IMS). The Integrated Magnetic Switch (IMS) is activated by the ignition switch. The solenoid circuit then engages the starting motor. The benefit of Integrated Magnetic Switch (IMS) is a lower current in the ignition circuit that will allow the engine ECM to control ignition without the use of a relay.

Alternator

The electrical outputs of the alternator have the following characteristics:

- Three-phase
- Full-wave
- Rectified

The alternator is an electro-mechanical component. The alternator is driven by a belt from the crankshaft pulley. The alternator charges the storage battery during the engine operation.

The alternator is cooled by an external fan which is mounted behind the pulley. The fan may be mounted internally. The fan forces air through the holes in the front of the alternator. The air exits through the holes in the back of the alternator.

The alternator converts the mechanical energy and the magnetic field into alternating current and voltage. This conversion is done by rotating a direct current electromagnetic field on the inside of a three-phase stator. The electromagnetic field is generated by electrical current flowing through a rotor. The stator generates alternating current and voltage.

The alternating current is changed to direct current by a three-phase, full-wave rectifier. Direct current flows to the output terminal of the alternator. The direct current is used for the charging process.

A regulator is installed on the rear end of the alternator. Two brushes conduct current through two slip rings. The current then flows to the rotor field. A capacitor protects the rectifier from high voltages.

The alternator is connected to the battery for charging and machine load requirements. A warning lamp can be connected via the ignition switch. This wiring is optional.

i04093630

Cleanliness of Fuel System Components

SMCS Code: 1250

Cleanliness of the Engine

NOTICE

It is important to maintain extreme cleanliness when working on the fuel system, since even tiny particles can cause engine or fuel system problems.

The entire engine should be washed with a high-pressure water system. Washing the engine will remove dirt and loose debris before a repair on the fuel system is started. Ensure that no high-pressure water is directed at the seals for the injectors.

Environment

When possible, the service area should be positively pressurized. Ensure that the components are not exposed to contamination from airborne dirt and debris. When a component is removed from the system, the exposed fuel connections must be closed off immediately with suitable sealing plugs. The sealing plugs should only be removed when the component is reconnected. The sealing plugs must not be reused. Dispose of the sealing plugs immediately after use. Contact your nearest Caterpillar dealer in order to obtain the correct sealing plugs.

New Components

High-pressure lines are not reusable. New high-pressure lines are manufactured for installation in one position only. When a high-pressure line is replaced, do not bend or distort the new line. Internal damage to the pipe may cause metallic particles to be introduced to the fuel.

All new fuel filters, high-pressure lines, tube assemblies, and components are supplied with sealing plugs. These sealing plugs should only be removed in order to install the new part. If the new component is not supplied with sealing plugs then the component should not be used.

The technician must wear suitable rubber gloves. The rubber gloves should be disposed of immediately after completion of the repair in order to prevent contamination of the system.

Refueling

In order to refuel the diesel fuel tank, the refueling pump and the fuel tank cap assembly must be clean and free from dirt and debris. Refueling should take place only when the ambient conditions are free from dust, wind, and rain.

Only use fuel that is free from contamination. Ultra Low Sulfur Diesel (ULSD) must be used. The content of sulfur in Ultra Low Sulfur Diesel (ULSD) fuel must be below 15 PPM 0.0015%.

Biodiesel may be used. The neat biodiesel must conform to the latest "EN14214 or ASTM D6751" (in the USA). The biodiesel can only be blended in mixture of up to 20% by volume in acceptable mineral diesel fuel meeting latest edition of "EN590 or ASTM D975 S15" designation.

In United States, Biodiesel blends of B6 to B20 must meet the requirements listed in the latest edition of "ASTM D7467" (B6 to B20) and must be of an API gravity of 30-45.

For more information, refer to Operation and Maintenance Manual, "Fluid Recommendations".

i04135694

Fuel Injection

SMCS Code: 1251; 1252; 1253; 1254; 1281

Introduction

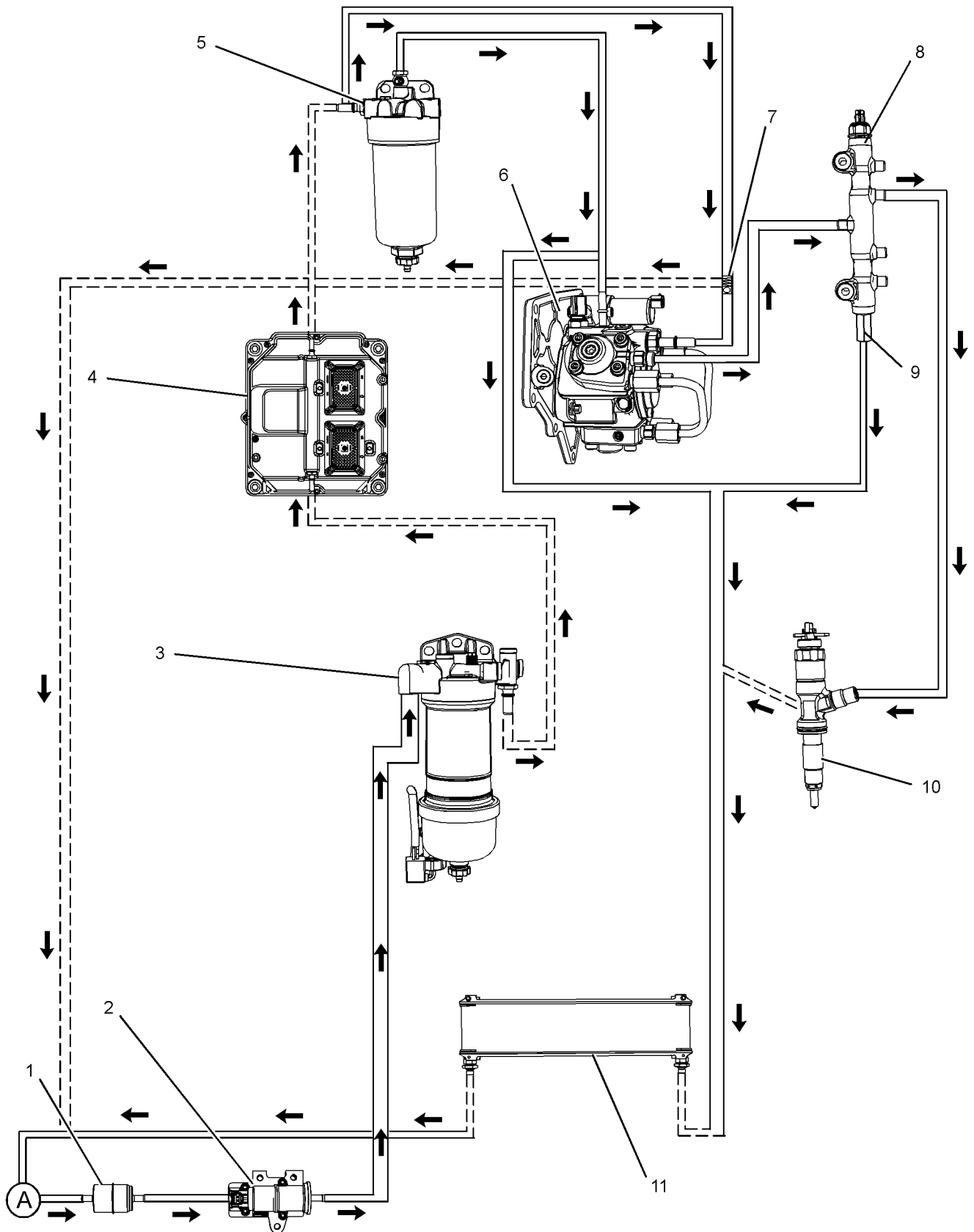

Illustration 28
Typical example

- | | | |
|------------------------------|------------------------------|-------------------------------|
| (1) Fuel strainer | (5) Secondary fuel filter | (9) Pressure relief valve |
| (2) Electric transfer pump | (6) Fuel Injection Pump | (10) Electronic unit injector |
| (3) Primary fuel filter | (7) Inlet pressure regulator | (11) Fuel cooler (optional) |
| (4) ECM that is fuel cooled. | (8) Fuel manifold (rail) | (A) Fuel tank |

Fuel is drawn from the fuel tank through a fuel strainer to an external electric transfer pump. The fuel then flows to the 10 micron primary fuel filter and a water separator.

The fuel may flow to a fuel cooled ECM. The fuel then flows to a 4 micron secondary fuel filter.

The fuel flows from the secondary fuel filter to a pressure regulator. A pressure regulator that is installed in the low-pressure fuel system controls the fuel pressure to the fuel injection pump. The pressure regulator regulates the fuel at a pressure of 150 kPa (22 psi) when the engine is at idle speed.

From the pressure regulator, the fuel flows to the fuel injection pump. The fuel is pumped at an increased pressure of 200 MPa (29000 psi) to the fuel manifold (rail).

Fuel that has too high a pressure from the fuel manifold (rail) returns through the pressure relief valve to the return line. Fuel that is leak off from the electronic unit injectors flows to the return line. The fuel may then flow through an optional fuel cooler on the way back to the fuel tank.

High Pressure Fuel System

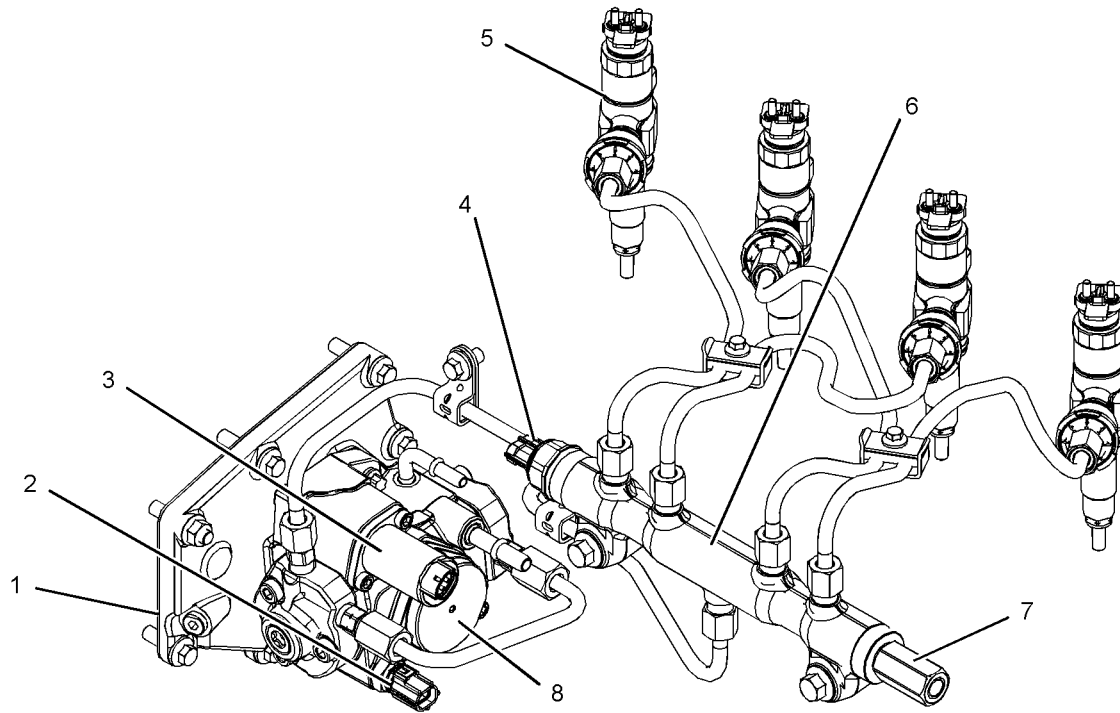

Illustration 29

g02450116

Typical example

- | | | |
|---|------------------------------|------------------------|
| (1) Fuel injection pump | (4) Fuel pressure sensor | (8) Fuel transfer pump |
| (2) Fuel temperature sensor | (5) Electronic unit injector | |
| (3) Suction control valve for the fuel injection pump | (6) Fuel manifold (rail) | |
| | (7) Pressure relief valve | |

The fuel injection pump (1) feeds fuel to the high-pressure fuel manifold (rail) (6). The fuel is at a pressure of 200 MPa (29000 psi). A pressure sensor (4) in the high-pressure fuel manifold (rail) (6) monitors the fuel pressure in the high-pressure fuel manifold (rail) (6). The ECM controls a suction control valve (3) in the fuel injection pump (1) in order to maintain the actual pressure in the high-pressure fuel manifold (6) at the desired level. The high-pressure fuel is continuously available at each injector. The ECM determines the correct time for activation of the correct electronic unit injector (5) which allows fuel to be injected into the cylinder. The leakoff fuel from each injector passes into a drilling which runs along the inside of the cylinder head. A pipe is connected to the rear of the cylinder head in order to return the leakoff fuel to the fuel tank.

Components of the Fuel Injection System

The fuel injection system has the following mechanical components:

- Primary filter/water separator
- Electric transfer pump

- Fuel transfer pump
- Secondary fuel filter
- Fuel injection pump
- Fuel injectors
- Fuel manifold
- Pressure relief valve
- Fuel pressure sensor
- Fuel temperature sensor

The following list contains examples of both service and repairs when you must prime the system:

- A fuel filter is changed.
- A low-pressure fuel line is replaced.
- The fuel injection pump is replaced.
- The ECM is replaced.

For the correct procedure to prime the fuel system, refer to Systems Operation, Testing and Adjusting, "Fuel System - Prime".

Primary Filter/Water Separator

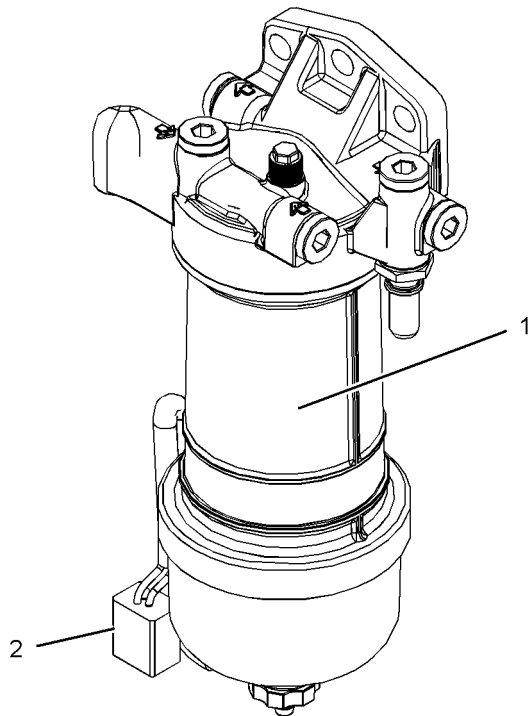

Illustration 30

g02214535

Typical example

The primary filter/water separator (1) is located between the electric lift pump and the secondary fuel filter. The primary filter/water separator (1) provides a 10 micron filtration level.

The primary filter/water separator can either be engine mounted or supplied loose. The primary filter/water separator is supplied with water in fuel sensor (2).

Secondary Fuel Filter

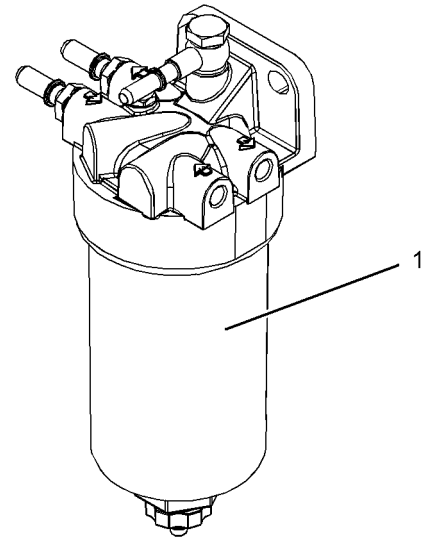

Illustration 31

g02214536

Typical example

The secondary fuel filter (1) is located after the primary fuel filter. The secondary fuel filter (1) provides a 4 micron filtration level.

Fuel Pump Assembly

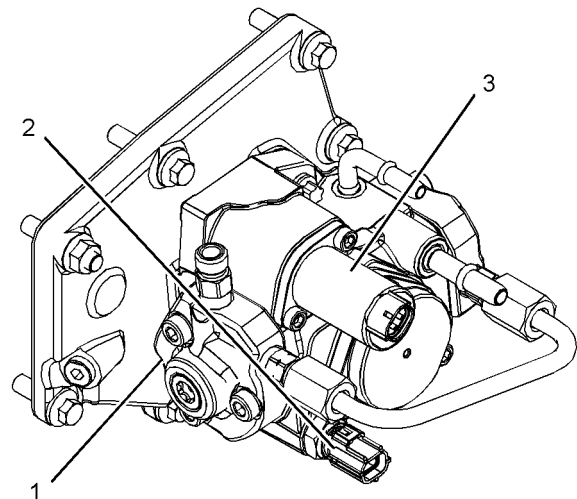

Illustration 32

g02450146

Typical example

The fuel pump assembly consists of a low-pressure transfer pump and a high-pressure fuel injection pump. The pump assembly is driven from a gear in the front timing case at engine speed. The fuel injection pump (1) has two plungers that are driven by a camshaft. The fuel injection pump (1) delivers a volume of fuel two times for each revolution. The stroke of the plungers are fixed.

The injector will use only part of the fuel that is delivered by each stroke of the pistons in the pump. The suction control valve (3) for the fuel injection pump (1) is controlled by the ECM. This maintains the fuel pressure in the fuel manifold (rail) at the correct level. A feature of the fuel injection pump (1) allows fuel to return to the tank continuously.

The fuel temperature sensor (2) measures the temperature of the fuel. The ECM receives the signal from the fuel temperature sensor (2). The ECM calculates the volume of fuel.

The fuel injection pump has the following operation:

- Generation of high-pressure fuel

The fuel output of the fuel injection pump is controlled by the ECM in response to changes in the demand of fuel pressure.

Shutoff

The engine shuts off by preventing the electronic unit injectors from injecting. The ECM then closes the suction control valve to prevent the pressure in the fuel manifold (rail) from increasing.

Control

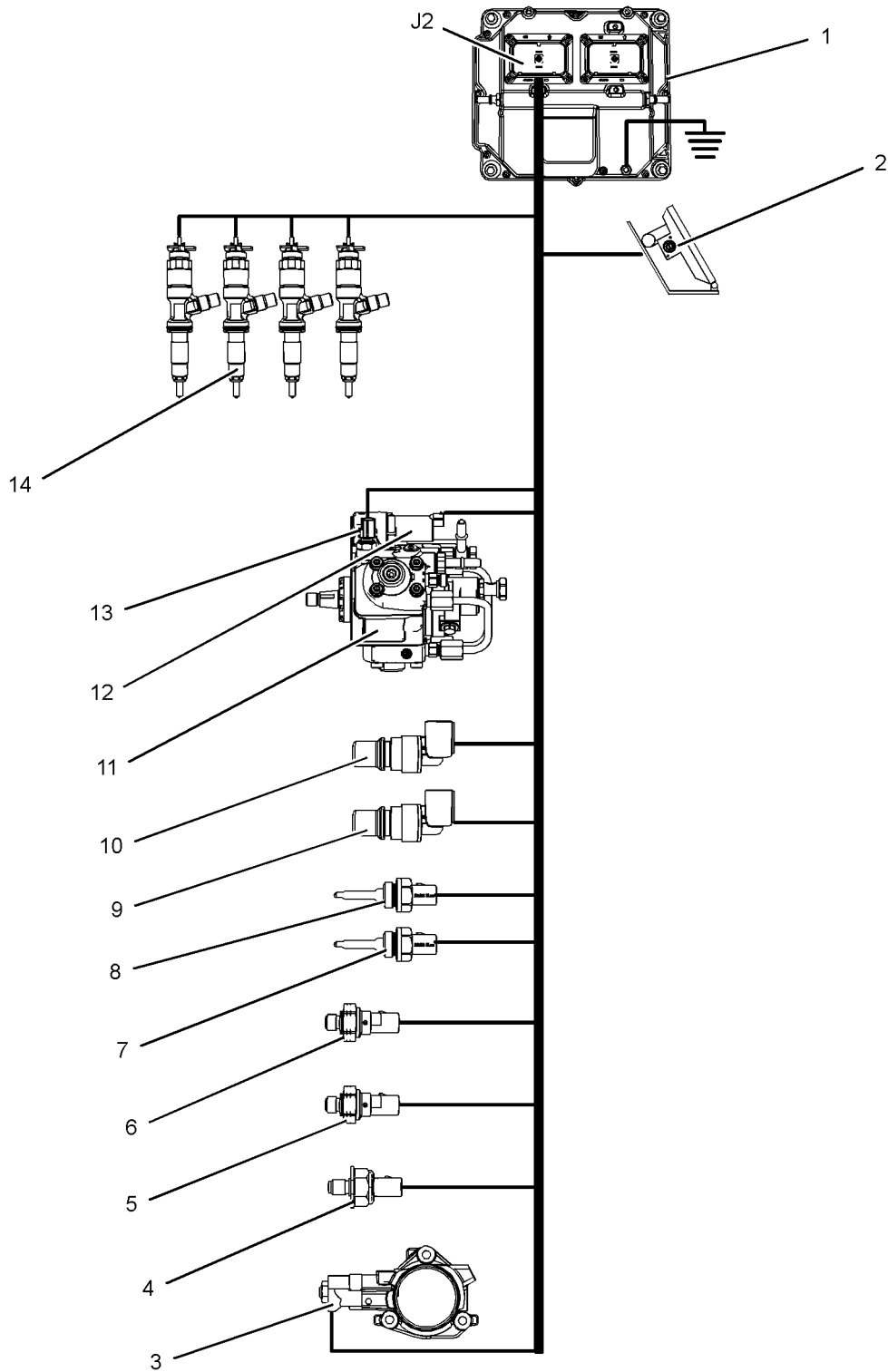

Illustration 33

g02450148

Typical example of the electrical control system for the fuel system

- | | | |
|-------------------------------------|---|--|
| (1) Electronic Control Module (ECM) | (6) Atmospheric pressure sensor | (11) Fuel injection pump |
| (2) Throttle position sensor | (7) Coolant temperature sensor | (12) Suction control valve for the fuel injection pump |
| (3) Wastegate regulator | (8) Inlet manifold air temperature sensor | (13) Fuel temperature sensor |
| (4) Fuel rail pressure sensor | (9) Secondary speed/timing sensor | (14) Electronic unit injectors |
| (5) Inlet manifold pressure sensor | (10) Primary speed/timing sensor | |

The ECM determines the quantity, timing, and pressure of the fuel in order to be injected into the fuel injector.

The ECM uses input from the sensors on the engine. These sensors include the speed/timing sensors and the pressure sensors.

The ECM controls the timing and the flow of fuel by actuating the injector solenoid.

The amount of fuel is proportional to the duration of the signal to the injector solenoid.

The ECM controls the fuel pressure by increasing or decreasing the flow of fuel from the fuel injection pump.

Fuel Injectors

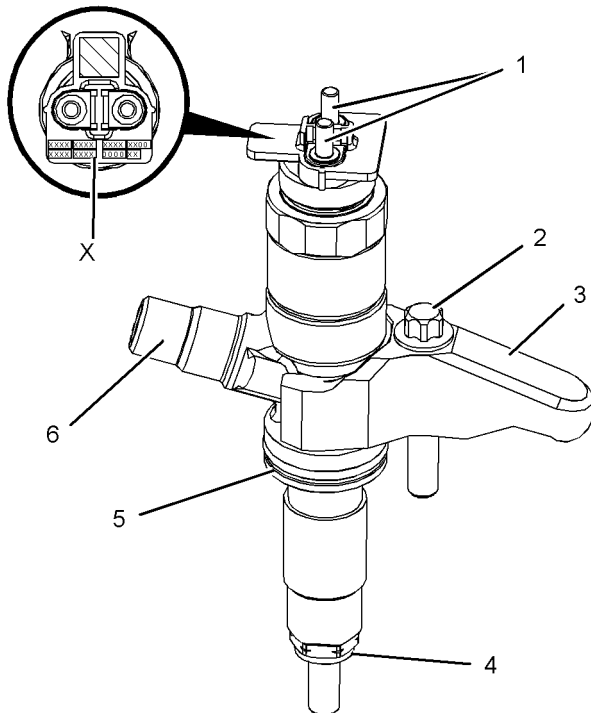

Illustration 34

g02290433

Typical example

- (1) Electrical connections
- (2) Bolt
- (3) Clamp
- (4) Combustion washer
- (5) O-ring
- (6) Fuel inlet

Note: If a replacement electronic unit injector is installed, the correct injector code must be programmed into the electronic control module. Refer to Troubleshooting, “Injector Code - Calibrate” for more information. The code that is required is located at Position (X). Record Code (X) before the electronic unit injector is installed.

The fuel injectors contain no serviceable parts apart from the O-ring seal and the combustion washer. The clamp and setscrew are serviced separately.

The pressurized fuel from the fuel manifold is injected into the combustion chamber by the electronic unit injector. The desired injection timing, injection quantity and injection pattern are controlled by the ECM depending on engine operating conditions.

The injection process is controlled using a two-way valve. The supply of electrical current to the solenoid controls the two-way valve. When the two-way valve is not energized the out orifice is closed and there is no fuel leak. In this condition the pressure in the control chamber and the pressure at the nozzle needle are the same. In this condition the spring pressure on the command piston keeps the needle closed.

When an injection of fuel is required, the electrical current from the ECM charges the solenoid, which in turn energizes the two-way valve and lifts the valve. When the valve lifts the valve uncovers the out orifice. The fuel starts to flow and reduces the pressure in the control chamber. When the pressure difference at the nozzle needle exceeds the combined pressure of the control chamber pressure and the spring pressure, the nozzle lifts to start the injection process. The fuel coming out of the nozzle is atomized and injected as a very fine spray.

When the injection needs to be stopped the electrical current to the solenoid is cut off and the pressure difference in the control chamber starts increasing. The increased pressure difference stops the injection process when the combined pressure exceeds the nozzle pressure.

The electronic unit injectors can be instructed to inject fuel multiple times during the combustion process. A close pilot injection occurs before the main injection. The close pilot injection helps to reduce NOx and noise. The main injection period helps to increase the torque of the engine. The after injection period helps to reduce the amount of smoke that is produced.

Fuel Manifold

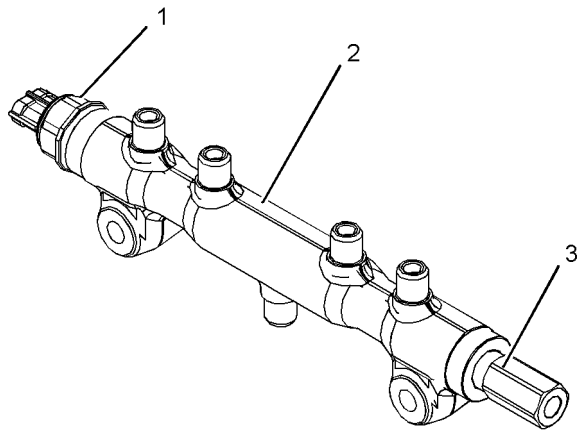

Illustration 35

g02149309

Typical example

The fuel manifold (2) stores high-pressure fuel from the fuel injection pump. The high-pressure fuel will flow to the injectors.

The fuel pressure sensor (1) measures the fuel pressure in the fuel manifold (3).

The pressure relief valve (3) will prevent the fuel pressure from getting too high.

The fuel pressure sensor must be replaced with the fuel manifold (rail). The pressure relief valve can be serviced as a separate component.

i04302989

Electronic Control System

SMCS Code: 1900

Introduction

The engine is designed for electronic control. The engine has an Electronic Control Module (ECM), a fuel injection pump and electronic unit injectors. All of these items are electronically controlled. There are also a number of engine sensors. The engine is equipped with an electronically controlled wastegate system for the turbocharger. The ECM controls the engine operating parameters through the software within the ECM and the inputs from the various sensors. The software contains parameters that control the engine operation. The parameters include all of the operating maps and customer-selected parameters.

The electronic control system has the following components:

- ECM
- Pressure sensor
- Temperature sensors
- Crankshaft speed/timing sensor
- Camshaft speed/timing sensor
- The suction control valve for the fuel injection pump
- Wastegate solenoid
- Electronic unit injectors
- Soot sensors

Engines with Series Turbochargers

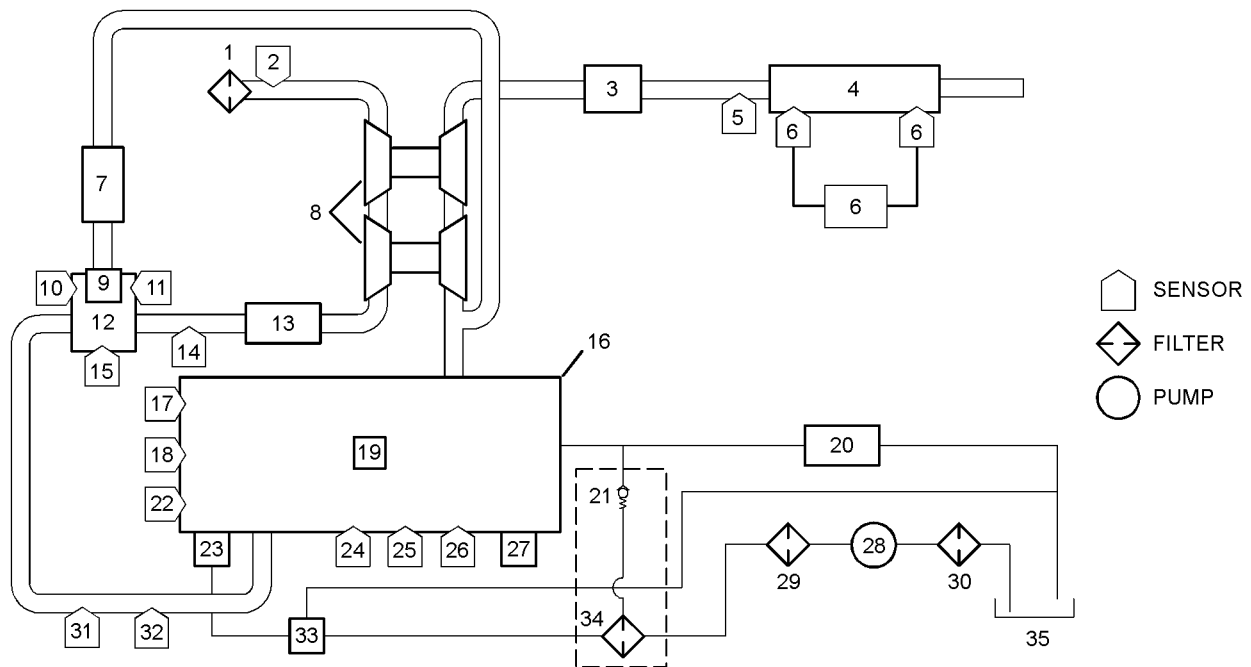

Illustration 36

g02476176

- | | | |
|---|--|--|
| (1) Air cleaner | (12) Exhaust gas valve for the NOx Reduction System (NRS) | (25) Oil pressure sensor |
| (2) Air inlet temperature sensor | (13) Air-to-air aftercooler | (26) Atmospheric pressure sensor |
| (3) Exhaust back pressure valve | (14) Wastegate regulator | (27) ECM |
| (4) Diesel Oxidation Catalyst (DOC) and Diesel Particulate Filter (DPF) | (15) Outlet pressure sensor for the NOx Reduction System (NRS) | (28) Fuel transfer pump |
| (5) Inlet temperature sensor for the DPF | (16) Engine | (29) Primary fuel filter |
| (6) Soot sensor | (17) Coolant temperature sensor | (30) Fuel strainer |
| (7) Exhaust Cooler for the NOx Reduction System (NRS) | (18) Crankshaft speed/timing sensor | (31) Boost pressure sensor |
| (8) Turbochargers | (19) Electronic unit injectors | (32) Inlet manifold temperature sensor |
| (9) Valve for the NOx Reduction System (NRS) | (20) Fuel cooler | (33) Transfer pump inlet regulator |
| (10) Temperature sensor for the NOx Reduction System (NRS) | (21) Fuel pressure relief valve | (34) Secondary fuel filter |
| (11) Inlet pressure sensor for the NOx Reduction System (NRS) | (22) Camshaft speed/timing sensor | (35) Fuel tank |
| | (23) Fuel injection pump and fuel temperature sensor | |
| | (24) Fuel pressure sensor | |

Engines with a Single Turbocharger

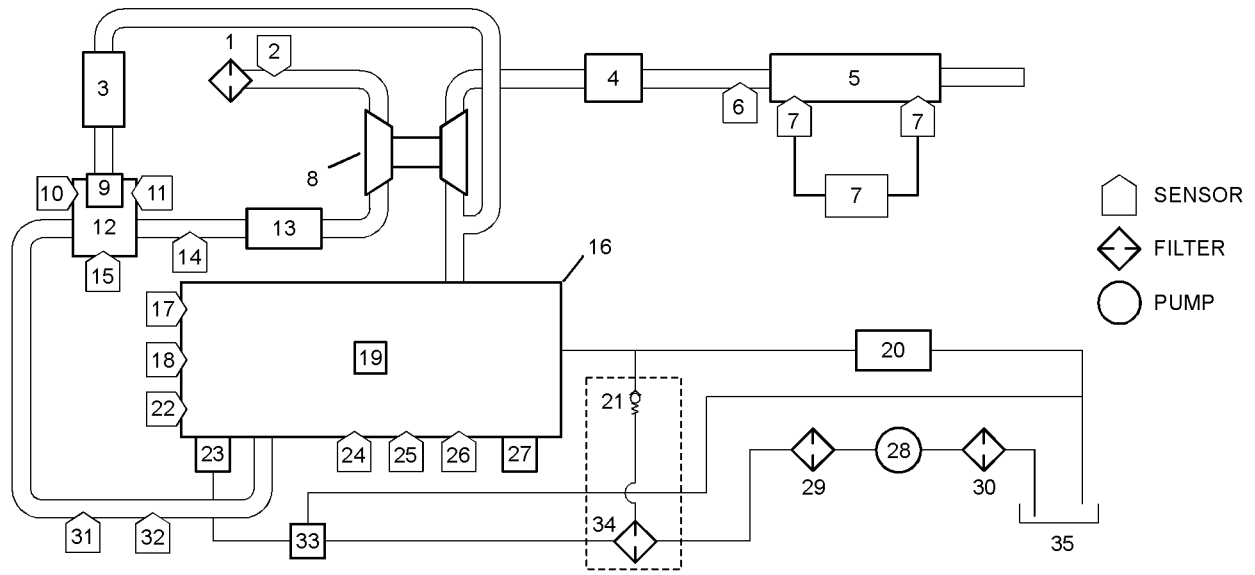

Illustration 37

g02420296

Typical example

- | | | |
|--|--|--|
| <ul style="list-style-type: none"> (1) Air cleaner (2) Air inlet temperature sensor (3) Exhaust Cooler for the NOx Reduction System (NRS) (4) Exhaust back pressure valve (5) Diesel Oxidation Catalyst (DOC) and Diesel Particulate Filter (DPF) (6) DPF inlet temperature sensor (7) Soot sensor (8) Turbocharger (9) Valve for the NOx Reduction System (NRS) (10) Temperature sensor for the NOx Reduction System (NRS) (11) Inlet pressure sensor for the NOx Reduction System (NRS) | <ul style="list-style-type: none"> (12) Exhaust gas valve for the NOx Reduction System (NRS) (13) Air-to-air aftercooler (14) Wastegate regulator (15) Outlet pressure sensor for the NOx Reduction System (NRS) (16) Engine (17) Coolant temperature sensor (18) Crankshaft speed/timing sensor (19) Electronic unit injectors (20) Fuel cooler (21) Fuel pressure relief valve (22) Camshaft speed/timing sensor (23) Fuel injection pump and fuel temperature sensor (24) Fuel pressure sensor | <ul style="list-style-type: none"> (25) Oil pressure sensor (26) Atmospheric pressure sensor (27) ECM (28) Fuel transfer pump (29) Primary fuel filter (30) Fuel strainer (31) Inlet manifold pressure sensor (32) Inlet manifold air temperature sensor (33) Transfer pump inlet regulator (34) Secondary fuel filter (35) Fuel tank |
|--|--|--|

Sensor Locations for the Engine

The illustrations in this section show the typical locations of the sensors for the industrial engine. Specific engines may appear different from the illustration due to differences in applications.

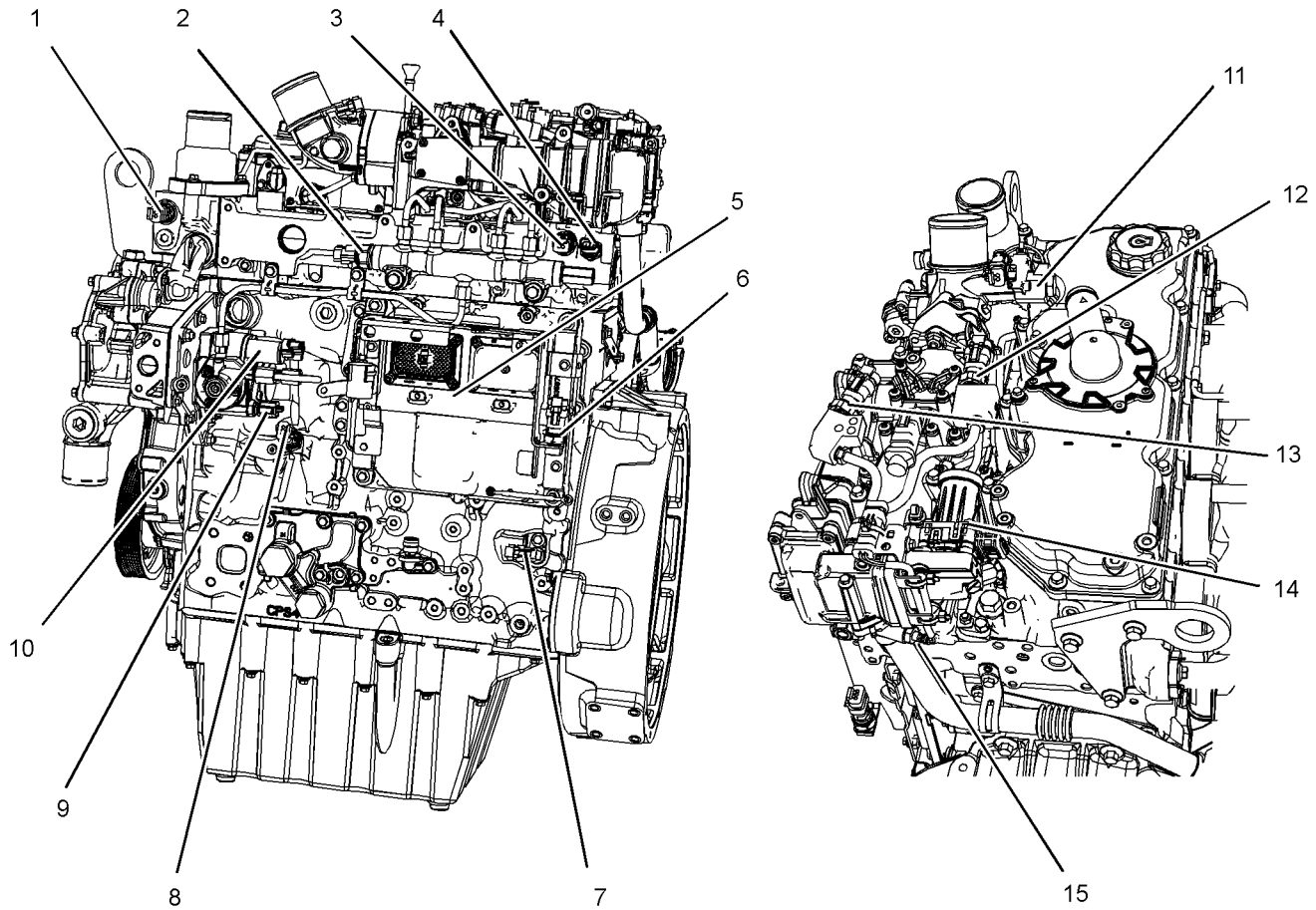

Illustration 38

g02476638

- (1) Coolant temperature sensor
- (2) Fuel pressure sensor
- (3) Inlet manifold temperature sensor
- (4) Boost pressure sensor
- (5) Electronic Control Module (ECM)
- (6) Atmospheric pressure sensor
- (7) Crankshaft speed/timing sensor

- (8) Engine oil pressure sensor
- (9) Fuel temperature sensor
- (10) Suction control valve for the fuel injection pump
- (11) Wastegate regulator
- (12) Inlet pressure sensor for the NOx Reduction System (NRS)

- (13) Outlet pressure sensor for the NOx Reduction System (NRS)
- (14) Exhaust gas valve for the NOx Reduction System (NRS)
- (15) Temperature sensor for the NOx Reduction System (NRS)

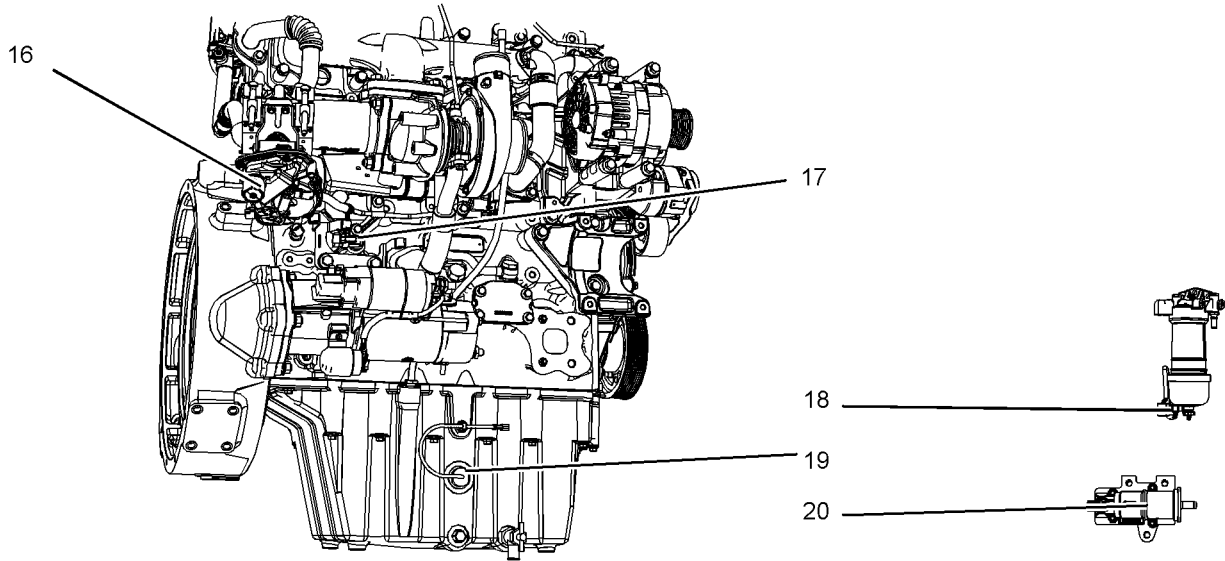

Illustration 39

g02476647

- (16) Exhaust back pressure valve
- (17) Camshaft speed/timing sensor

- (18) Water in fuel switch
- (19) Oil level switch (if equipped)

- (20) Electric fuel transfer pump

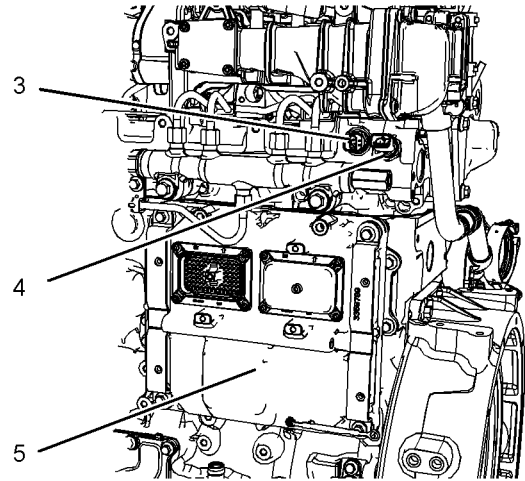
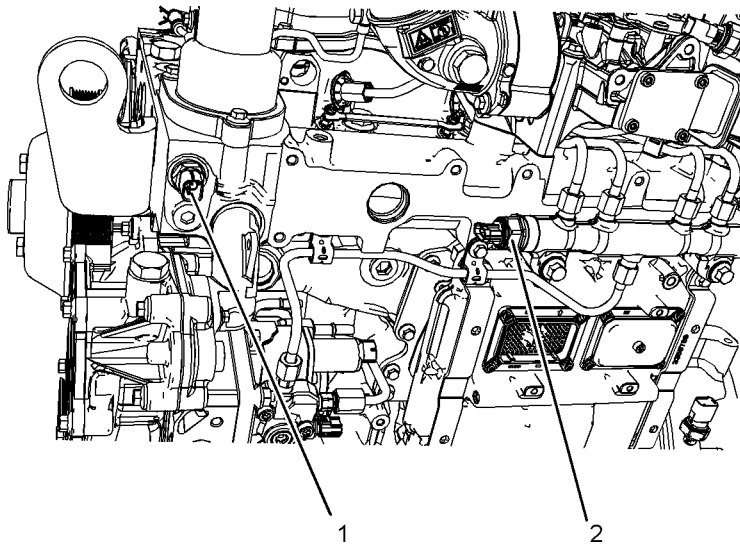

Illustration 40

g02476653

- (1) Coolant temperature sensor
- (2) Fuel pressure sensor

- (3) Inlet manifold temperature sensor
- (4) Boost pressure sensor

- (5) Electronic Control Module (ECM)

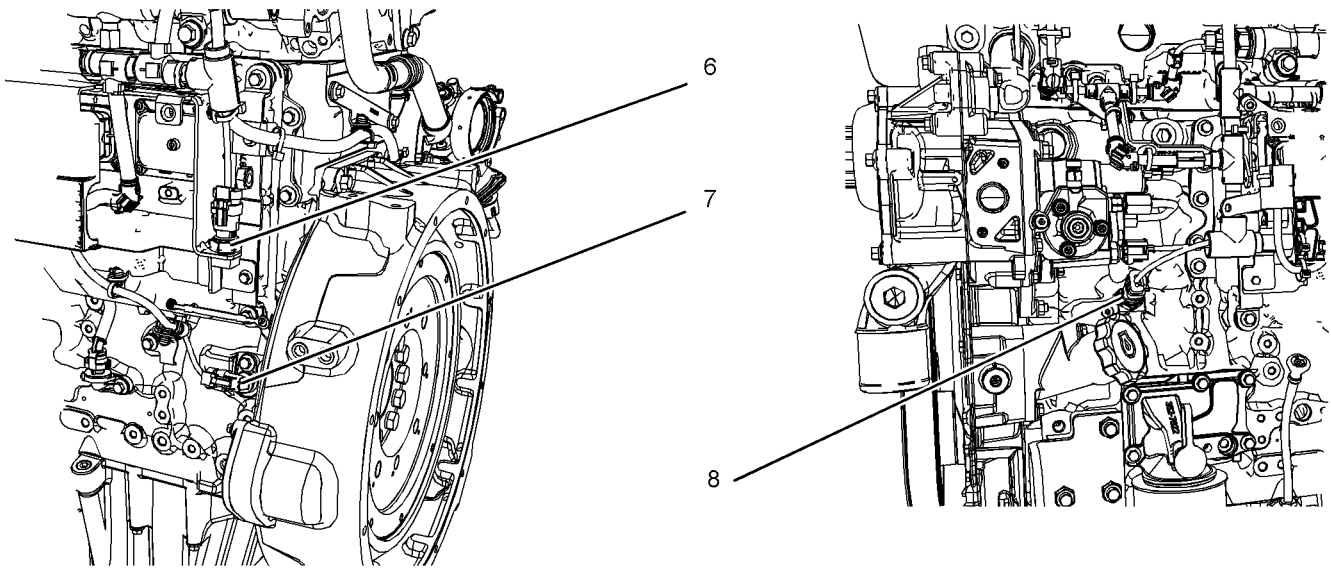

Illustration 41

g02476657

(6) Atmospheric pressure sensor

(7) Crankshaft speed/timing sensor

(8) Engine oil pressure sensor

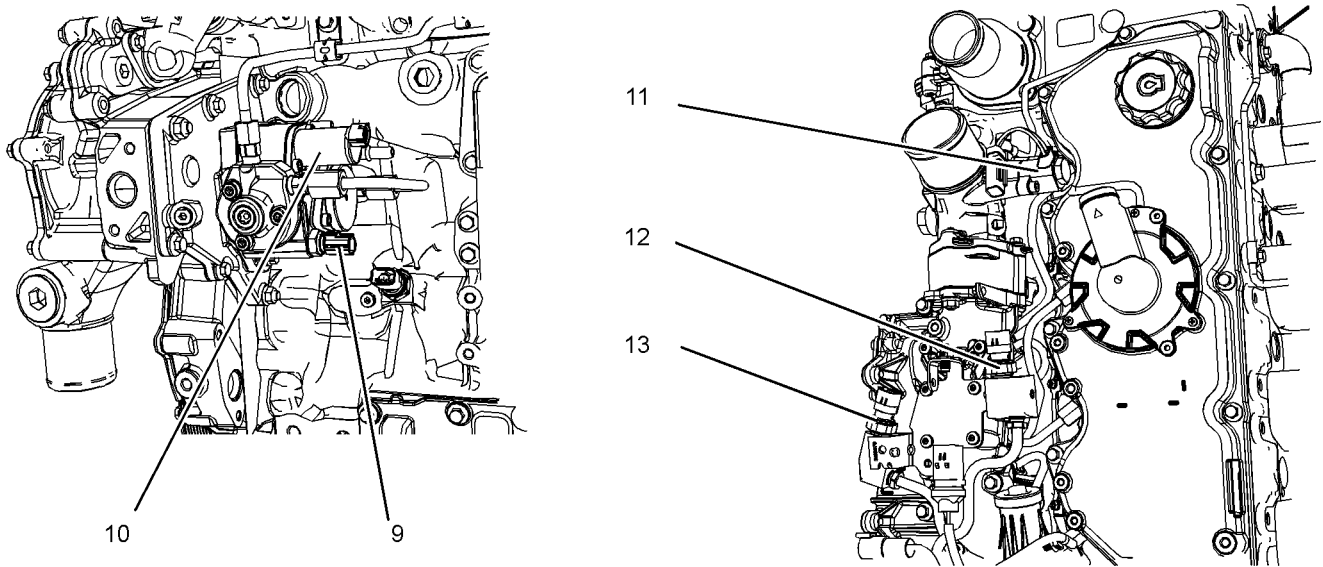

Illustration 42

g02476662

(9) Fuel temperature sensor
(10) Suction control valve for the fuel injection pump

(11) Wastegate regulator
(12) Inlet pressure sensor for the NOx Reduction System (NRS)

(13) Outlet pressure sensor for the NOx Reduction System (NRS)

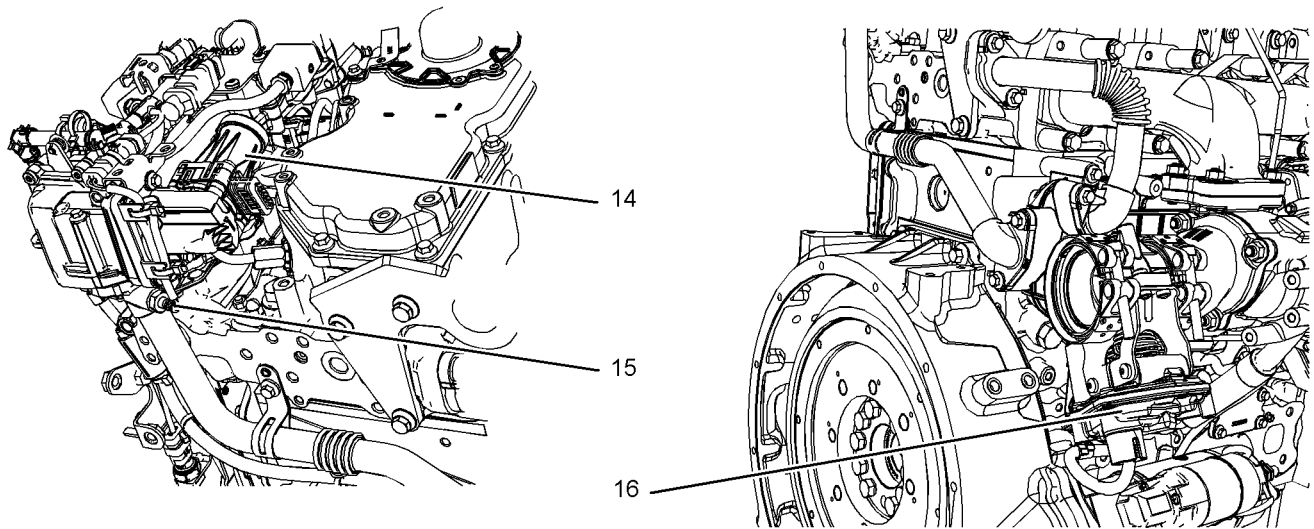

Illustration 43

g02476672

(14) Exhaust gas valve for the NOx Reduction System (NRS)

(15) Temperature sensor for the NOx Reduction System (NRS)

(16) Exhaust back pressure valve

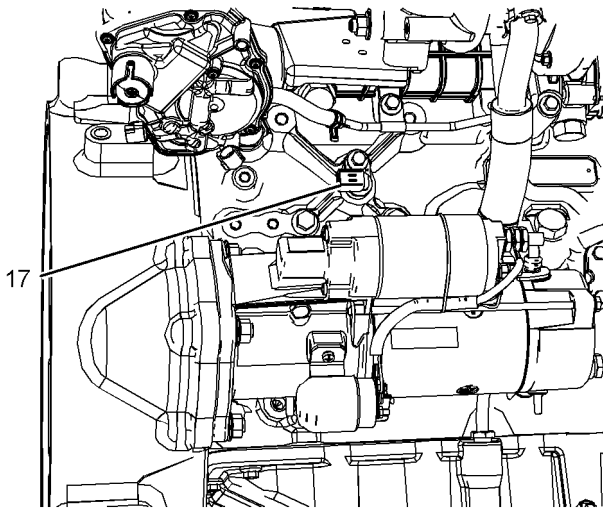

Illustration 44

g02476674

(17) Camshaft speed/timing sensor

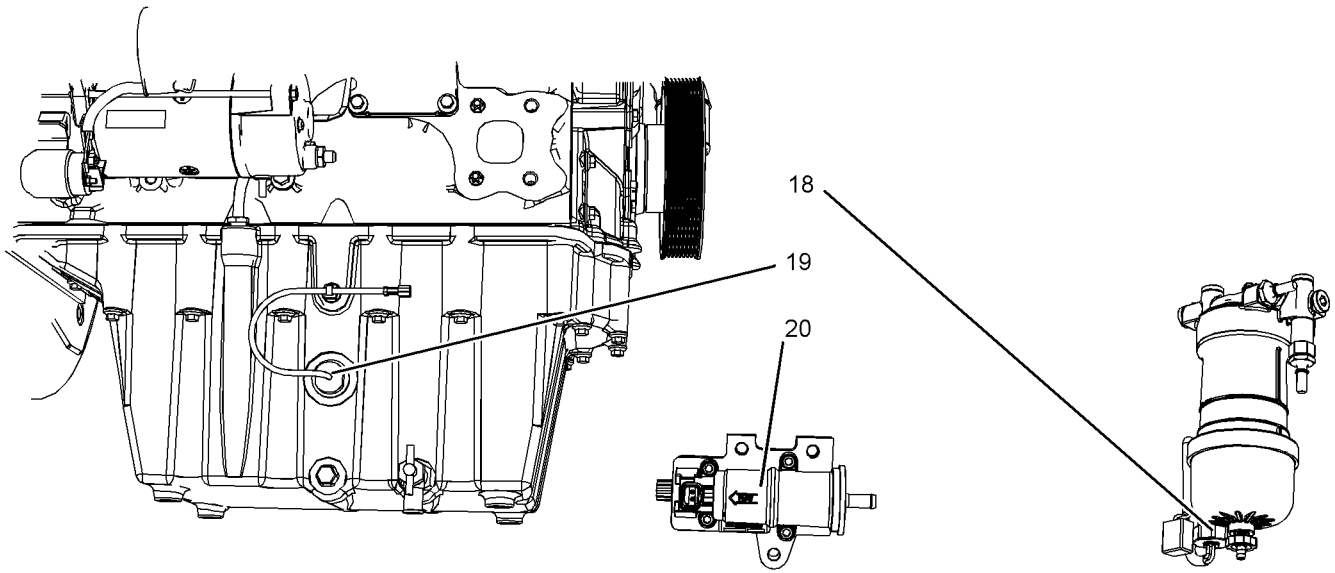

Illustration 45

g02476676

(18) Water in fuel switch

(19) Oil level switch (if equipped)

(20) Electric fuel transfer pump

Sensor Locations for the Clean Emissions Module

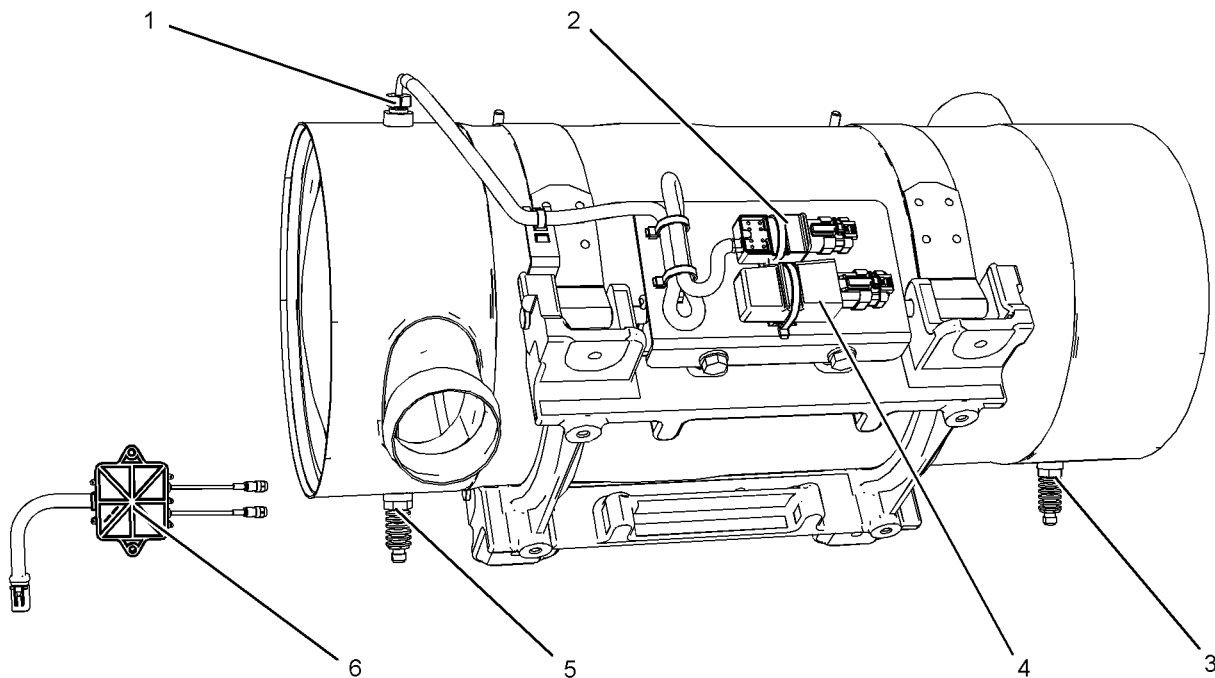

Illustration 46

g02395776

Typical example

(1) Temperature sensor

(2) Connector for temperature sensor

(3) Soot sensor connection

(4) Aftertreatment identification module

(5) Soot sensor connection

(6) Soot sensor module

Note: The location of the soot sensor module will depend on the application.

ECM

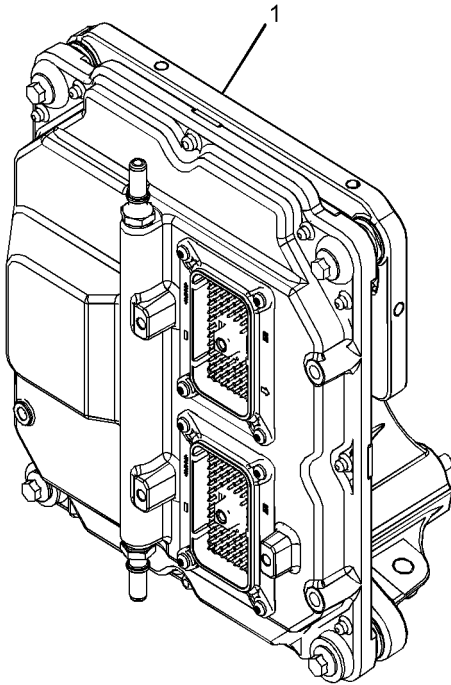

Illustration 47
Typical example

g01926054

The Electronic Control Module (ECM) (1) functions as a governor and a computer for the fuel system. The ECM receives signals from the sensors in order to control the timing and the engine speed.

The electronic system consists of the ECM, the engine sensors, and inputs from the parent machine. The ECM is the computer. The personality module is the software for the computer. The personality module contains the operating maps. The operating maps define the following characteristics of the engine:

- Engine rating
- Torque curves
- High and low idle speed (rpm)
- Emissions
- Injection timing

The factory passwords restrict changes to authorized personnel. Factory passwords are required to clear any event code. Refer to Troubleshooting, “Factory Passwords” for more information on the passwords.

The ECM has an excellent record of reliability. Any problems in the system are most likely to be the connectors and the wiring harness. The ECM should be the last item in troubleshooting the engine.

The programmable software contains all the fuel setting information. The information determines the engine performance.

Flash programming is the method of programming or updating the programmable software. Refer to Troubleshooting, “Flash Programming” for the instructions on the flash programming of the programmable software.

The ECM is sealed and the ECM needs no routine adjustment or maintenance.

Engine Speed

The electronic controls determine the injection timing, the amount of fuel that is delivered to the cylinders and the intake manifold pressure if an electronically controlled wastegate is installed. These decisions are based on the actual conditions and the desired conditions at any given time.

The ECM has software that compares the desired engine speed to the actual engine speed. The actual engine speed is determined through the crankshaft speed/timing sensor and the camshaft speed/timing sensor. If the desired engine speed is greater than the actual engine speed, the ECM will instruct the electronic unit injector to inject more fuel in order to increase engine speed.

Timing Considerations

Once the ECM has determined the amount of fuel that is required, the software must determine the timing of the fuel injection. Fuel injection timing is determined by the ECM after considering input from the following components:

- Engine coolant temperature sensor
- The sensor for the intake manifold air temperature
- The sensor for the intake manifold pressure

At start-up, the ECM determines the top center position of the number 1 cylinder from the secondary speed/timing sensor on the camshaft. The ECM decides when fuel injection should occur relative to the top center position. The ECM optimizes engine performance by control of each of the electronic unit injectors so that the required amount of fuel is injected at the precise point of the engine's cycle. The electronic unit injectors are supplied high-pressure fuel from the fuel manifold. The ECM also provides the signal to the solenoid in the fuel injection pump. The solenoid in the fuel injection pump controls a valve in the fuel injection pump. This valve controls the volume of fuel that enters the plungers. By controlling the volume of fuel that enters the plungers, this controls the pressure in the fuel manifold. Fuel that is not required for the engine is diverted away from the fuel injection pump back to the fuel tank.

The ECM adjusts injection timing and fuel pressure for the best engine performance, the best fuel economy, and the best control of exhaust emissions. The actual timing can be viewed with an electronic service tool. Also, the desired timing can be viewed with an electronic service tool.

Fuel Injection

The programmable software inside the ECM sets certain limits on the amount of fuel that can be injected.

The FRC Limit is a limit that is based on intake manifold air pressure and engine rpm. The FRC Limit is used to control the air/fuel ratio in order to control the engine's exhaust emissions. When the ECM senses a higher intake manifold air pressure, the ECM increases the FRC Limit. A higher intake manifold air pressure indicates that there is more air in the cylinder. When the ECM increases the FRC Limit, the ECM allows more fuel into the cylinder.

The Rated Fuel Limit is a limit that is based on the power rating of the engine and on the engine rpm. The Rated Fuel Limit enables the engine power and torque outputs to conform to the power and torque curves of a specific engine model.

These limits are in the programmable software and these limits cannot be changed.

The ECM controls the following characteristics:

- Boost pressure
- Operation of the NOx reduction system

Diagnostic Codes

When the ECM detects an electronic system problem, the ECM generates a diagnostic code. Also, the ECM logs the diagnostic code in order to indicate the time of the problems occurrence. The ECM also logs the number of occurrences of the problem. Diagnostic codes are provided in order to indicate that the ECM has detected an electrical problem or an electronic problem with the engine control system. In some cases, the engine performance can be affected when the condition that is causing the code exists.

If the operator indicates that a performance problem occurs, the diagnostic code may indicate the cause of the problem. Use a laptop computer to access the diagnostic codes. The problem should then be corrected.

Event Codes

Event Codes are used to indicate that the ECM has detected an abnormal engine operating condition. The ECM will log the occurrence of the event code. This does not indicate an electrical malfunction or an electronic malfunction. If the temperature of the coolant in the engine is higher than the permitted limit, then the ECM will detect the condition. The ECM will then log an event code for the condition.

Passwords

System Configuration Parameters are protected by factory passwords. This will prevent unauthorized reprogramming of the system and the unauthorized removal of logged events. Factory passwords are calculated on a computer system that is available only to Caterpillar dealers. Since factory passwords contain alphabetic characters, only an electronic service tool may change System Configuration Parameters. System Configuration Parameters affect the power rating or the emissions. Passwords also allow the customer to control certain programmable engine parameters.

Refer to Troubleshooting, "Programming Parameters" and Troubleshooting, "Factory Passwords".

Speed/Timing Sensors

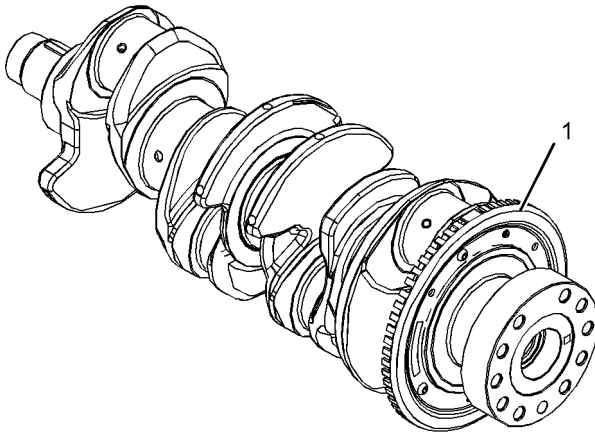

Illustration 48

g02155463

Typical example

The primary speed/timing sensor is located on the left-hand side of the cylinder block close to the flywheel housing. The primary speed/timing sensor generates a signal by detecting the movement of the teeth that are located on the crankshaft timing ring (1). The signal that is generated by the speed/timing sensor is transmitted to the ECM. The ECM uses the signal from the speed/timing sensor to calculate the position of the crankshaft. The signal is also used to determine the engine speed.

The secondary speed/timing sensor is located on the right-hand side of the cylinder block toward the rear of the engine. The secondary speed/timing sensor generates a signal that is related to the camshaft position. The secondary speed/timing sensor detects the movement of the teeth on the timing ring (2) for the camshaft. The signal that is generated by the speed/timing sensor is transmitted to the ECM. The ECM calculates the speed and the rotational position of the engine by using the signal. The secondary speed/timing sensor is required for starting purposes.

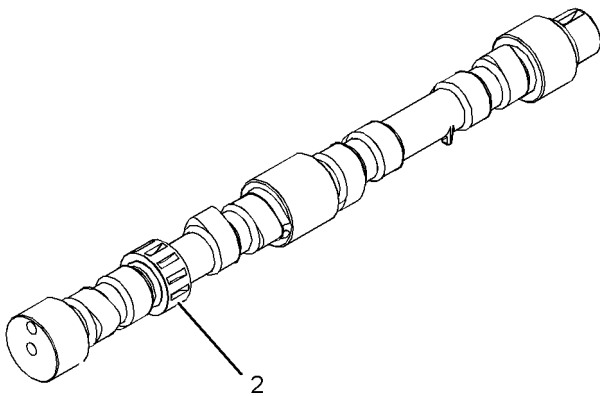

Illustration 49

g02476196

Typical example

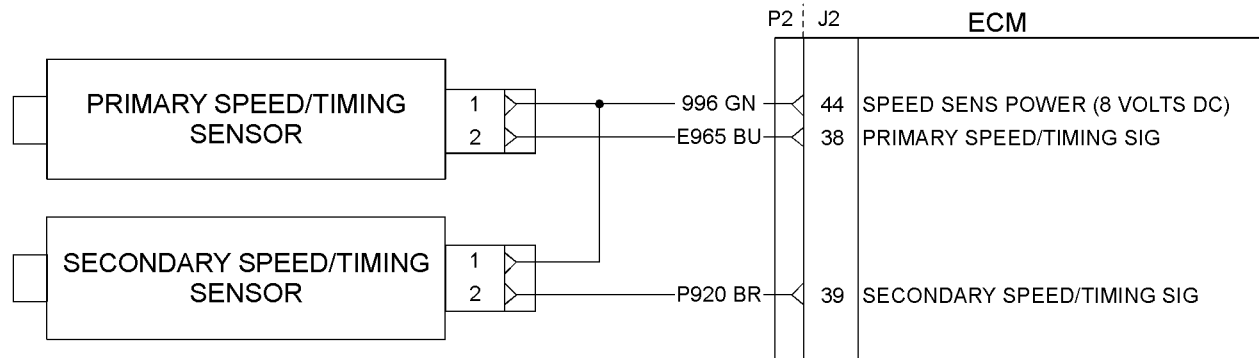

Illustration 50
Schematic for speed/timing sensor

g01878676

When the engine is cranking, the ECM uses the signal from the speed/timing sensor on the camshaft. When the engine is running the ECM uses the signal from the speed/timing sensor on the crankshaft. This speed/timing sensor is the primary source of the engine position.

Pressure Sensors

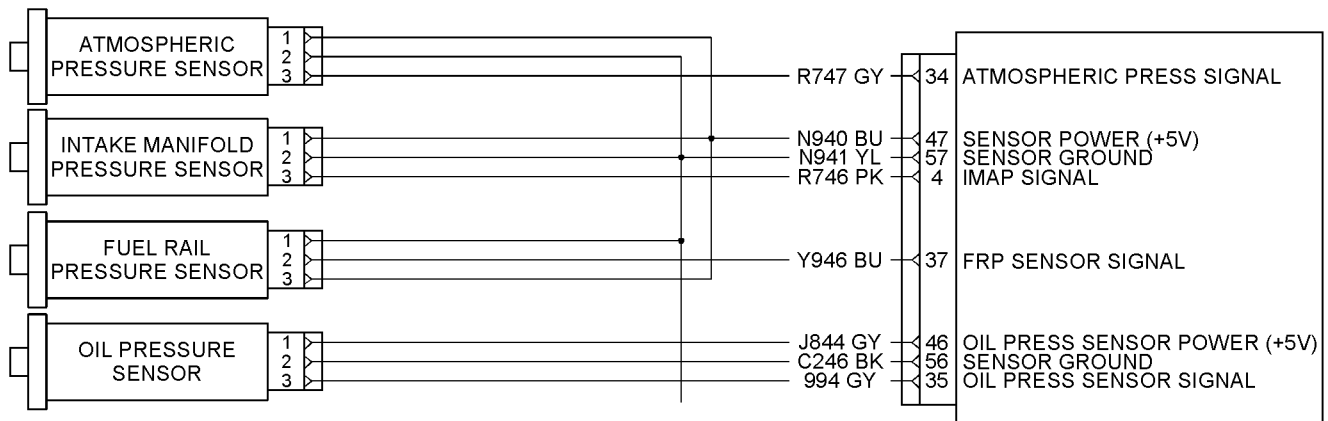

Illustration 51
Schematic for the pressure sensors

g02139716

The boost pressure sensor and the engine oil pressure sensor are active sensors.

The boost pressure sensor provides the ECM with a measurement of inlet manifold pressure in order to control the air/fuel ratio. This will reduce the engine smoke during transient conditions.

The operating range of the boost pressure sensors is 39 to 400 kPa (6 to 58 psi).

The engine oil pressure sensor provides the ECM with a measurement of engine oil pressure. The ECM can warn the operator of possible conditions that can damage the engine. This includes the detection of an oil filter that is blocked.

The operating range for the engine oil pressure sensor 13 to 1200 kPa (2 to 174 psi)

Temperature Sensors

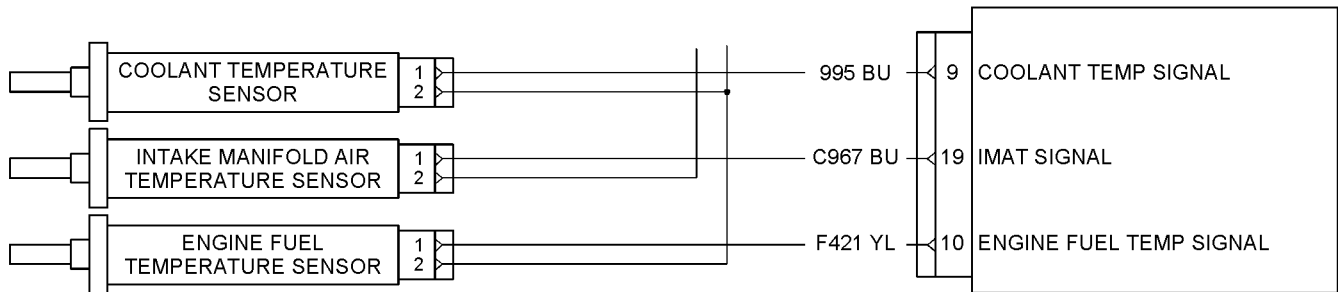

Illustration 52

g02139713

Schematic for the engine temperature sensors

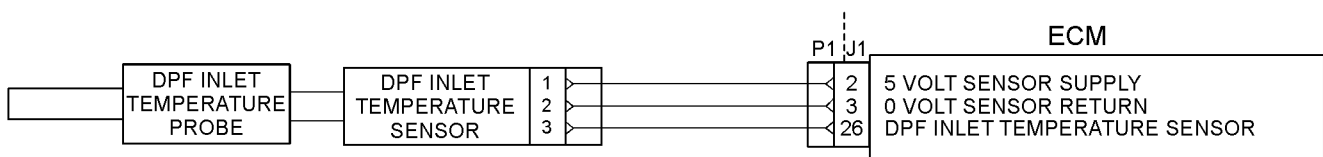

Illustration 53

g02139706

Schematic for the temperature sensors for the engine aftertreatment system

The air inlet temperature sensor and the coolant temperature sensor are passive sensors. Each sensor provides a temperature input to the ECM. The ECM controls following operations:

- Fuel delivery
- Injection timing

The operating range for the sensors ... -40° to 125°C (-40° to 257°F)

The operating range for the fuel temperature sensor -40° to 120°C (-40° to 248°F)

The sensors are also used for engine monitoring.

Sensors for the NOx Reduction System (NRS)

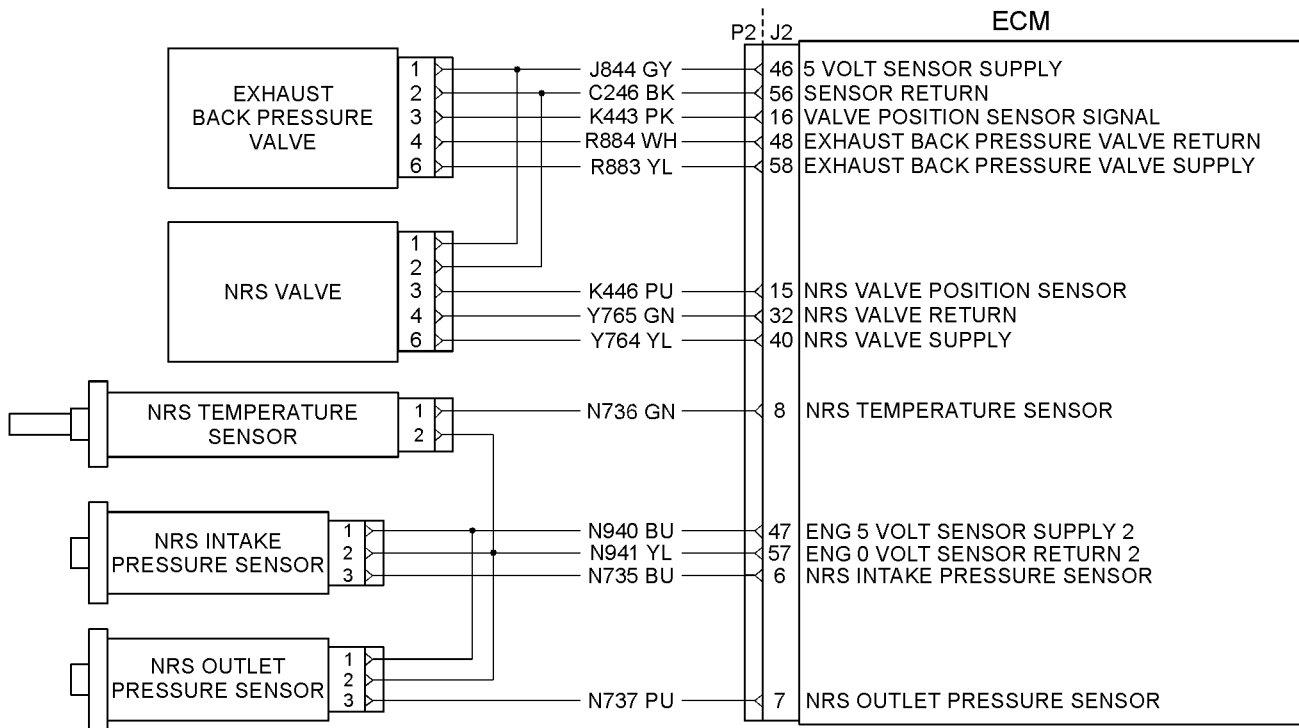

Illustration 54

g02139786

A typical example of a schematic of the position sensors for the NOx Reduction System (NRS)

i04252009

Power Sources

SMCS Code: 4480

Introduction

The engine supplies power to the ECM. The ECM powers the following components:

- All sensors on the engine
- The suction control valve for the fuel injection pump
- The solenoid for the wastegate
- Diagnostic connector
- Electronic unit injectors

The glow plugs are powered directly from the battery.

ECM Power Supply

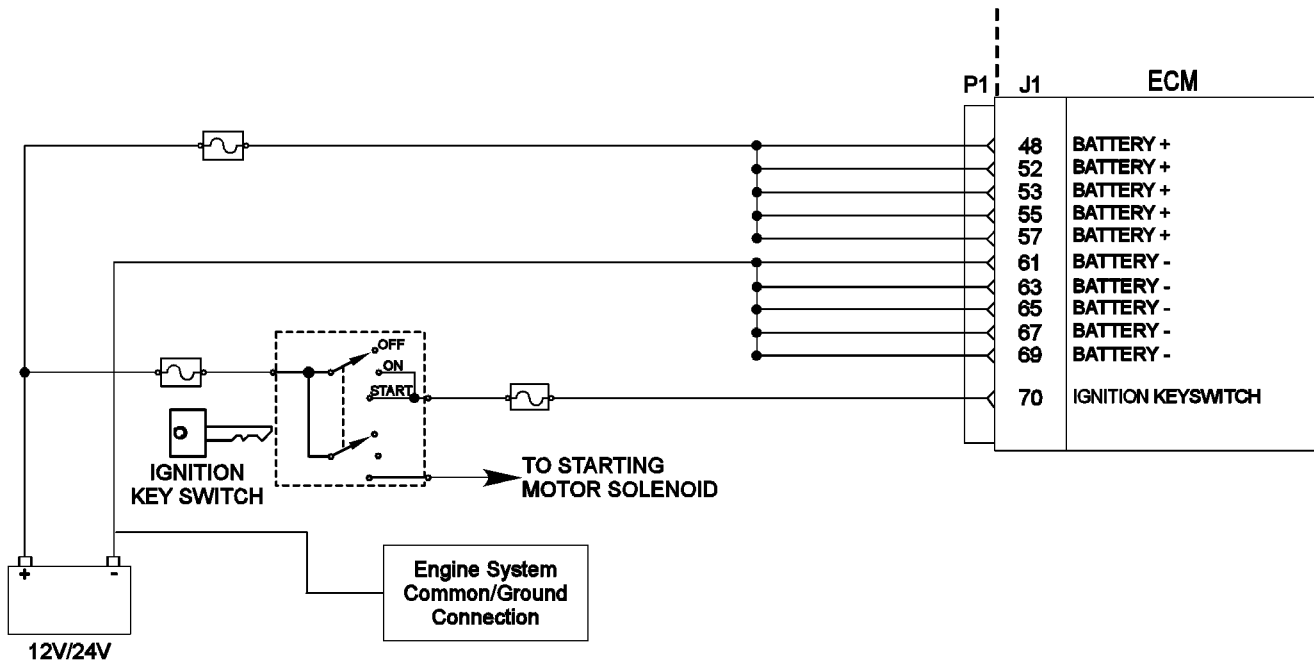

Illustration 55
Typical example

g02423278

The power supply to the ECM and the system is drawn from the 24 V or the 12 V battery. The power supply for the ECM has the following components:

- Battery
- Disconnect switch
- Ignition keyswitch
- Fuses
- Ground bolt
- ECM connector
- Machine interface connector

The Schematic for the ECM shows the main components for a typical power supply circuit. Battery voltage is normally connected to the ECM. The input from the ignition keyswitch turns on the ECM.

The wiring harness can be bypassed for troubleshooting purposes.

The display screen on the electronic service tool can be used in order to check the voltage supply.

Power Supply for the Pressure Sensors

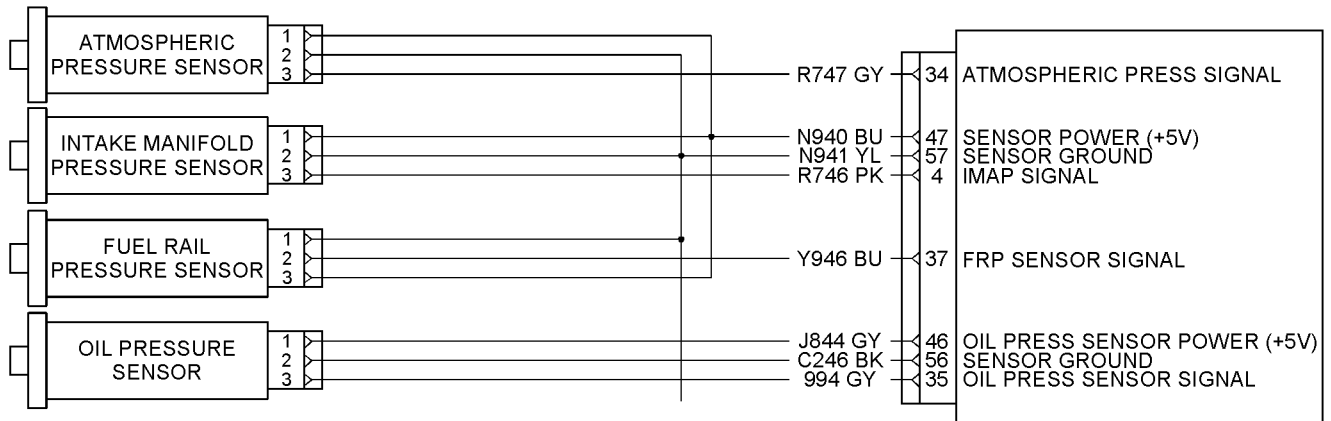

Illustration 56

g02139716

Schematic for pressure sensors

The ECM supplies 5 VDC volts through the ECM connector to each sensor. The power supply is protected against short circuits. A short in a sensor or a wiring harness will not cause damage to the ECM.

Power Supply for the Glow plugs

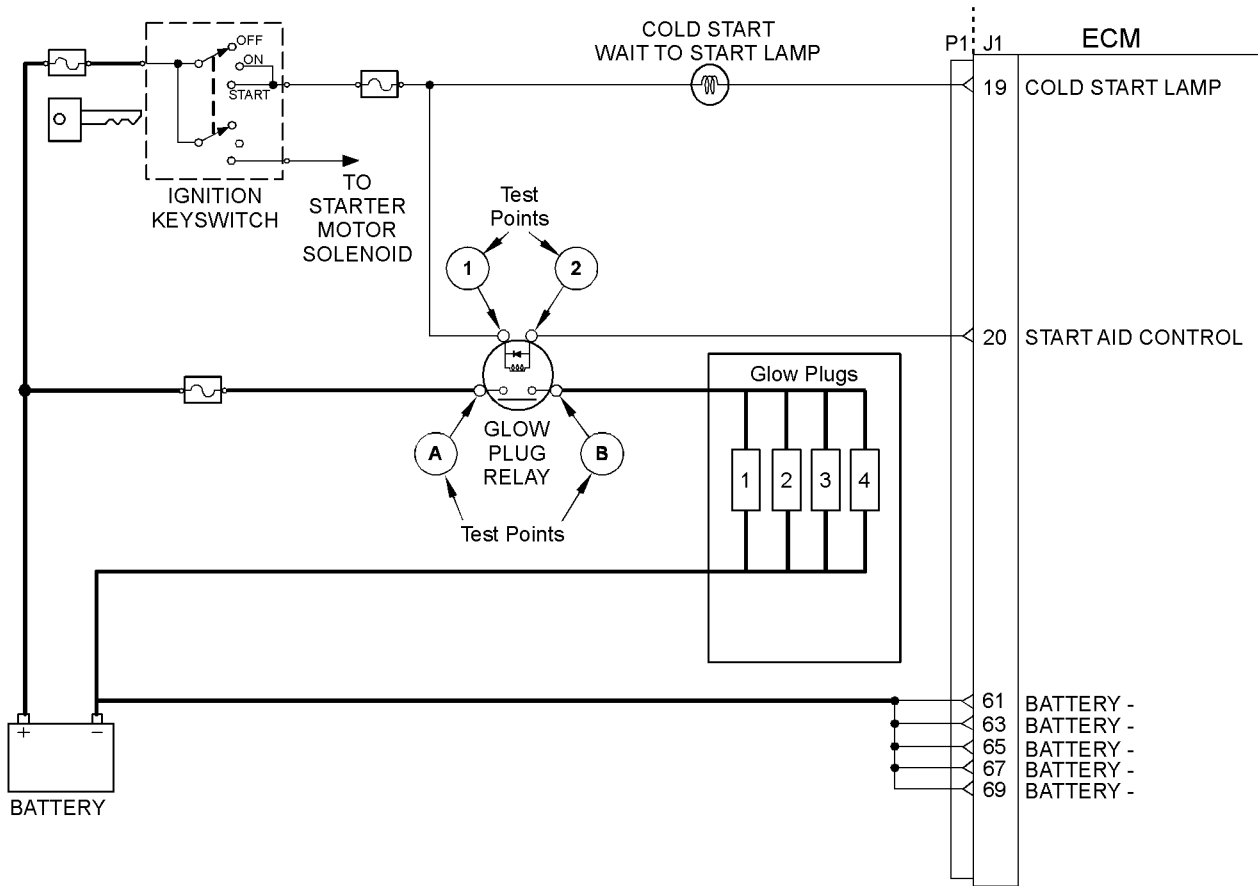

Illustration 57
Typical example

g02149319

Glossary of Electronic Control Terms

SMCS Code: 1900

Active Diagnostic Code – An active diagnostic code alerts the operator or the service technician that an electronic system malfunction is currently present. Refer to the term “Diagnostic Code” in this glossary.

Aftertreatment – Aftertreatment is a system that is used to remove pollutants from exhaust gases. The system consists of a Diesel Oxidation Catalyst (DOC) and a Catalyzed Diesel Particulate Filter (CDPF).

Air-To-Air Aftercooler – An air-to-air aftercooler is a device that is used on turbocharged engines in order to cool inlet air that has undergone compression. The inlet air is cooled after the inlet air passes through the turbocharger. The inlet air is passed through an aftercooler (heat exchanger) that uses ambient air for cooling. The inlet air that has been cooled advances to the inlet manifold.

Alternating Current (AC) – Alternating current is an electric current that reverses direction at a regular interval that is reoccurring.

Before Top Center (BTC) – BTC is the 180 degrees of crankshaft rotation before the piston reaches the top center position in the normal direction of rotation.

Boost Pressure – The difference between the turbocharger outlet pressure and atmospheric pressure is commonly referred to as boost pressure. The sensor for the intake manifold air pressure measures the amount of boost.

i04245249

Breakout Harness – The breakout harness is a test harness that is designed to connect into the engine harness. This connection allows a normal circuit operation and the connection simultaneously provides a Breakout T in order to measure the signals.

Bypass Circuit – A bypass circuit is a circuit that is used as a substitute circuit for an existing circuit. A bypass circuit is typically used as a test circuit.

CAN Data Link (see also J1939 CAN Data Link) – The CAN Data Link is a serial communications port that is used for communication with other microprocessor-based devices.

Catalyzed Diesel Particulate Filter – The Catalyzed Diesel Particulate Filter (CDPF) filters particulates from the exhaust gases. A coating on the internal surfaces reacts with the hot exhaust gases in order to burn off the particulates. This process prevents the CDPF from becoming blocked with soot.

Caterpillar NOx Reduction System – The Caterpillar NOx Reduction System recycles a portion of the exhaust gases back into the inlet air in order to reduce the amount of nitrous oxide (NOx) in the exhaust gases. The recycled exhaust gas passes through a cooler before being introduced into the inlet air.

Code – Refer to “Diagnostic Code” or “Event Code”.

Cold Mode – Cold mode is a mode for cold starting and for cold engine operation. This mode is used for engine protection, reduced smoke emissions, and faster warm-up time.

Communication Adapter Tool – The communication adapter provides a communication link between the ECM and the Electronic Service Tool.

Component Identifier (CID) – The CID is a number that identifies the specific component of the electronic control system that has experienced a diagnostic code.

Coolant Temperature Sensor – The coolant temperature sensor detects the engine coolant temperature for all normal operating conditions and for engine monitoring.

Customer Specified Parameters – A customer specified parameter is a parameter that can be changed in the ECM with the Electronic Service Tool. A customer specified parameters value is set by the customer. These parameters are protected by customer passwords.

Data Link – The Data Link is a serial communication port that is used for communication with other microprocessor-based devices.

Derate – Certain engine conditions will generate event codes. Also, engine derates may be applied. The map for the engine derate is programmed into the ECM software. The derate can be one or more of three types: reduction of rated power, reduction of rated engine speed, and reduction of rated machine speed for OEM products.

Desired Engine Speed – The desired engine speed is input to the electronic governor within the ECM. The electronic governor uses the signal from the throttle position sensor, the engine speed/timing sensor, and other sensors in order to determine the desired engine speed.

Diagnostic Trouble Code – A diagnostic trouble code is sometimes referred to as a fault code. These codes indicate an electronic system malfunction.

Diagnostic Lamp – A diagnostic lamp is sometimes called the check engine lamp. The diagnostic lamp is used to warn the operator of the presence of an active diagnostic code. The lamp may not be included in all applications.

Diesel Oxidation Catalyst – The Diesel Oxidation Catalyst is also known as the (DOC). The DOC is a device in the exhaust system that oxidizes certain elements in the exhaust gases. These elements can include carbon monoxide (CO), hydrocarbons and the soluble organic fraction (SOF) of particulate matter.

Digital Sensor Return – The common line (ground) from the ECM is used as ground for the digital sensors.

Digital Sensors – Digital sensors produce a pulse width modulated signal. Digital sensors are supplied with power from the ECM.

Digital Sensor Supply – The power supply for the digital sensors is provided by the ECM.

Direct Current (DC) – Direct current is the type of current that flows consistently in only one direction.

DT, DT Connector, or Deutsch DT – This is a type of connector that is used on the engines. The connectors are manufactured by Deutsch.

Duty Cycle – Refer to “Pulse Width Modulation”.

Electronic Engine Control – The electronic engine control is a complete electronic system. The electronic engine control monitors the engine operation under all conditions. The electronic engine control also controls the engine operation under all conditions.

Engine Control Module (ECM) – The ECM is the control computer of the engine. The ECM provides power to the electronics. The ECM monitors data that is input from the sensors of the engine. The ECM acts as a governor in order to control the speed and the power of the engine.

Electronic Service Tool – The electronic service tool allows a computer (PC) to communicate with the ECM.

Engine Monitoring – Engine Monitoring is the part of the electronic engine control that monitors the sensors. This also warns the operator of detected problems.

Engine Oil Pressure Sensor – The engine oil pressure sensor measures engine oil pressure. The sensor sends an electronic signal to the ECM that is dependent on the engine oil pressure.

Engine Speed/Timing Sensor – An engine speed/timing sensor is a Hall effect switch that provides a digital signal to the ECM. The ECM interprets this signal as the crankshaft position and the engine speed. Two sensors are used to provide the speed and timing signals to the ECM. The primary sensor is associated with the crankshaft and the secondary sensor is associated with the camshaft.

Estimated Dynamic Timing – Estimated dynamic timing is the estimate of the actual injection timing that is calculated by the ECM.

Event Code – An event code may be activated in order to indicate an abnormal engine operating condition. These codes usually indicate a mechanical problem instead of an electrical system problem.

Exhaust Back Pressure Valve – The exhaust back pressure valve regulates the gas pressure in the exhaust system. The valve can restrict the flow of exhaust gases in order to increase the exhaust back pressure. An increase in exhaust back pressure will increase the temperature of the exhaust gases which will improve the process that burns off the soot in the CDPF.

Failure Mode Identifier (FMI) – This identifier indicates the type of failure that is associated with the component. The FMI has been adopted from the SAE practice of J1587 diagnostics. The FMI follows the parameter identifier (PID) in the descriptions of the fault code. The descriptions of the FMIs are in the following list.

0 – The data is valid but the data is above the normal operational range.

1 – The data is valid but the data is below the normal operational range.

2 – The data is erratic, intermittent, or incorrect.

3 – The voltage is above normal or the voltage is shorted high.

4 – The voltage is below normal or the voltage is shorted low.

5 – The current is below normal or the circuit is open.

6 – The current is above normal or the circuit is grounded.

7 – The mechanical system is not responding properly.

8 – There is an abnormal frequency, an abnormal pulse width, or an abnormal time period.

9 – There has been an abnormal update.

10 – There is an abnormal rate of change.

11 – The failure mode is not identifiable.

12 – The device or the component is damaged.

13 – The device requires calibration.

14 – There is a special instruction for the device.

15 – The signal from the device is high (least severe).

16 – The signal from the device is high (moderate severity).

17 – The signal from the device is low (least severe).

18 – The signal from the device is low (moderate severity).

19 – There is an error in the data from the device.

31 – The device has failed and the engine has shut down.

Flash File – This file is software that is inside the ECM. The file contains all the instructions (software) for the ECM and the file contains the performance maps for a specific engine. The file may be reprogrammed through flash programming.

Flash Programming – Flash programming is the method of programming or updating an ECM with an electronic service tool over the data link instead of replacing components.

Fuel Injector E-Trim – The fuel injector E-trim is a process in the software that allows precise control of fuel injectors by parameters that are programmed into the ECM for each fuel injector. With the use of the electronic service tool, the service technician can read status information for the E-Trim. Data for E-Trim can also be programmed.

Fuel Injection Pump – This item is sometimes referred to as the High Pressure Fuel Rail Pump. This is a device that supplies fuel under pressure to the fuel rail (high-pressure fuel rail).

Fuel Manifold (Rail) – This item is sometimes referred to as the High Pressure Fuel Rail. The fuel rail supplies fuel to the electronic unit injectors. The fuel rail pump and the fuel rail pressure sensor work with the ECM in order to maintain the desired fuel pressure in the fuel rail. This pressure is determined by calibration of the engine in order to enable the engine to meet emissions and performance requirements.

Fuel Manifold (Rail) Pressure Sensor – The fuel rail pressure sensor sends a signal to the ECM that is dependent on the pressure of the fuel in the fuel rail.

Fuel Ratio Control (FRC) – The FRC is a limit that is based on the control of the ratio of the fuel to air. The FRC is used for purposes of emission control. When the ECM senses a higher intake manifold air pressure (more air into the cylinder), the FRC increases the FRC Limit (more fuel into the cylinder).

The Solenoid Valve for the Fuel Injection Pump – This is sometimes referred to as the High Pressure Fuel Rail Pump Solenoid Valve or the Suction Control Valve. This is a control device in the fuel injection pump. The ECM controls the pressure in the fuel rail by using this valve to divert excess fuel from the pump to the fuel tank.

Full Load Setting (FLS) – The FLS is the number that represents the fuel system adjustment. This adjustment is made at the factory in order to fine-tune the fuel system. The correct value for this parameter is stamped on the engine information ratings plate. This parameter must be programmed.

Full Torque Setting (FTS) – The FTS is the parameter that represents the adjustment for the engine torque. This adjustment is made at the factory in order to fine-tune the fuel system. This adjustment is made with the FLS. This parameter must be programmed.

Glow Plug – The glow plug is an optional starting aid for cold conditions. One glow plug is installed in each combustion chamber in order to improve the ability of the engine to start. The ECM uses information from the engine sensors such as the engine temperature to determine when the glow plug relay must provide power to each glow plug. Each of the glow plugs then provides a hot surface in the combustion chamber in order to vaporize the mixture of air and fuel. This improves ignition during the compression stroke of the cylinder.

Glow Plug Relay – The glow plug relay is controlled by the ECM in order to provide high current to the glow plugs that are used in the starting aid system.

Harness – The harness is the bundle of wiring (loom) that connects all components of the electronic system.

Hertz (Hz) – Hertz is the unit of frequency in cycles per second.

High Pressure Fuel Rail Pump – See “Fuel Injection Pump”.

High Pressure Fuel Rail – See “Fuel Manifold (Rail)”.

Injector Trim Codes – Injector trim codes are codes that contain 30 characters. The codes are supplied with new injectors. The code is input through the electronic service tool into the ECM. The injector trim codes compensate for variances in the manufacturing of the electronic unit injector and for the life of the electronic unit injector.

Inlet Manifold Air Temperature Sensor – The inlet manifold air temperature sensor detects the air temperature in the inlet manifold. The ECM monitors the air temperature and other data in the inlet manifold in order to adjust injection timing and other performance functions.

Inlet Manifold Pressure Sensor – The Inlet Manifold Pressure Sensor measures the pressure in the inlet manifold. The pressure in the inlet manifold may be different to the pressure outside the engine (atmospheric pressure). The difference in pressure may be caused by an increase in air pressure by a turbocharger (if equipped).

Integrated Electronic Controls – The engine is designed with the electronic controls as a necessary part of the system. The engine will not operate without the electronic controls.

J1939 CAN Data Link – This data link is a SAE standard diagnostic communications data link that is used to communicate between the ECM and other electronic devices.

Logged Diagnostic Codes – Logged diagnostic codes are codes which are stored in the memory. These codes are an indicator of possible causes for intermittent problems. Refer to the term “Diagnostic Code” for more information.

OEM – OEM is an abbreviation for the Original Equipment Manufacturer. This is the manufacturer of the machine or the vehicle that uses the engine.

Open Circuit – An open circuit is a condition that is caused by an open switch, or by an electrical wire or a connection that is broken. When this condition exists, the signal or the supply voltage can no longer reach the intended destination.

Parameter – A parameter is a value or a limit that is programmable. This helps determine specific characteristics or behaviors of the engine.

Password – A password is a group of numeric characters or a group of alphanumeric characters that is designed to restrict access to parameters. The electronic system requires correct passwords in order to change some parameters (Factory Passwords). Refer to Troubleshooting, “Factory Passwords” for more information.

Power Cycling – Power cycling refers to the action of cycling the keyswitch from any position to the OFF position, and to the START/RUN position.

Programmable Software – The software is programmed into the ECM. The software contains all the instructions (software) for the ECM and the software contains the performance maps for a specific engine. The software may be reprogrammed through flash programming.

Primary Speed/Timing Sensor – This sensor determines the position of the crankshaft during engine operation. If the primary speed/timing sensor fails during engine operation, the secondary speed/timing sensor is used to provide the signal.

Pulse Width Modulation (PWM) – The PWM is a signal that consists of pulses that are of variable width. These pulses occur at fixed intervals. The ratio of “TIME ON” versus total “TIME OFF” can be varied. This ratio is also referred to as a duty cycle.

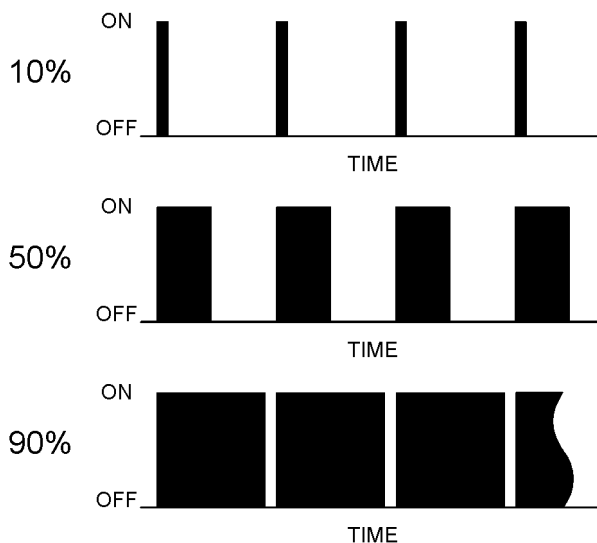

Illustration 58

g01858875

Rated Fuel Limit – This is a limit that is based on the power rating of the engine and on the engine rpm. The Rated Fuel Limit enables the engine power and torque outputs to conform to the power and torque curves of a specific engine model. These limits are in the flash file and these limits cannot be changed.

Reference Voltage – Reference voltage is a regulated voltage and a steady voltage that is supplied by the ECM to a sensor. The reference voltage is used by the sensor to generate a signal voltage.

Relay – A relay is an electromechanical switch. A flow of electricity in one circuit is used to control the flow of electricity in another circuit. A small current or voltage is applied to a relay in order to switch a much larger current or voltage.

Secondary Speed/Timing Sensor – This sensor determines the position of the camshaft during engine operation. If the primary speed/timing sensor fails during engine operation, the secondary speed/timing sensor is used to provide the signal.

Sensor – A sensor is a device that is used to detect the current value of pressure or temperature, or mechanical movement. The information that is detected is converted into an electrical signal.

Short Circuit – A short circuit is a condition that has an electrical circuit that is inadvertently connected to an undesirable point. An example of a short circuit is a wire which rubs against a vehicle frame and this rubbing eventually wears off the wire insulation. Electrical contact with the frame is made and a short circuit results.

Signal – The signal is a voltage or a waveform that is used in order to transmit information typically from a sensor to the ECM.

Suction Control Valve (SCV) – The SCV is a control device in the high-pressure fuel pump. The ECM controls the pressure in the fuel rail by using this valve to control the amount of fuel that enters the chambers in the pump.

Supply Voltage – The supply voltage is a continuous voltage that is supplied to a component in order to provide the electrical power that is required for the component to operate. The power may be generated by the ECM or the power may be battery voltage that is supplied by the engine wiring.

System Configuration Parameters – System configuration parameters are parameters that affect emissions and/or operating characteristics of the engine.

Tattletale – Certain parameters that affect the operation of the engine are stored in the ECM. These parameters can be changed by use of the electronic service tool. The tattletale logs the number of changes that have been made to the parameter. The tattletale is stored in the ECM.

Theft Deterrent – This feature uses a four-digit code in order to prevent the engine from starting. The feature requires a password to be entered via the CAT ID.

“T” Harness – This harness is a test harness that is designed to permit normal circuit operation and the measurement of the voltage simultaneously. Typically, the harness is inserted between the two ends of a connector.

Throttle Position – The throttle position is the interpretation by the ECM of the signal from the throttle position sensor or the throttle switch.

Throttle Position Sensor – The throttle position sensor is an electronic sensor that is connected to an accelerator pedal or a hand lever. This sensor sends a signal to the ECM that is used to calculate desired engine speed.

Throttle Switch – The throttle switch sends a signal to the ECM that is used to calculate desired engine speed.

Top Center Position – The top center position refers to the crankshaft position when the engine piston position is at the highest point of travel. The engine must be turned in the normal direction of rotation in order to reach this point.

Total Tattletale – The total tattletale is the total number of changes to all the parameters that are stored in the ECM.

Wait To Start Lamp – This is a lamp that is included in the cold starting aid circuit in order to indicate when the wait to start period is active. The lamp will go off when the engine is ready to be started. The glow plugs may not have deactivated now.

Wastegate – This is a device in a turbocharged engine that controls the maximum boost pressure that is provided to the inlet manifold.

Wastegate Regulator – The wastegate regulator controls the pressure in the inlet manifold to a value that is determined by the ECM. The wastegate regulator provides the interface between the ECM and the mechanical system that regulates inlet manifold pressure to the desired value that is determined by the software.

i04302509

Testing and Adjusting Section

Fuel System

i04081693

Fuel System - Inspect

SMCS Code: 1250-040

NOTICE

Ensure that all adjustments and repairs that are carried out to the fuel system are performed by authorized personnel that have the correct training.

Before beginning ANY work on the fuel system, refer to Operation and Maintenance Manual, "General Hazard Information and High Pressure Fuel Lines" for safety information.

Refer to Systems Operation, Testing and Adjusting, "Cleanliness of Fuel System Components" for detailed information on the standards of cleanliness that must be observed during ALL work on the fuel system.

A problem with the components that transport fuel to the engine can cause low fuel pressure. This can decrease engine performance.

1. Check the fuel level in the fuel tank. Ensure that the vent in the fuel cap is not filled with dirt.
2. Check that the valve in the fuel return line is open before the engine is started.
3. Check all low-pressure fuel lines for fuel leakage. The fuel lines must be free from restrictions and faulty bends. Verify that the fuel return line is not collapsed.
4. Install new fuel filters.
5. Cut the old filter open with a suitable filter cutter. Inspect the filter for excess contamination. Determine the source of the contamination. Make the necessary repairs.

Air in Fuel - Test

SMCS Code: 1280-081

Table 1

Required Tools			
Tool	Part Number	Part Description	Qty
A	375-2691	Sight gauge	1

NOTICE

Ensure that all adjustments and repairs that are carried out to the fuel system are performed by authorized personnel that have the correct training.

Before beginning ANY work on the fuel system, refer to Operation and Maintenance Manual, "General Hazard Information and High Pressure Fuel Lines" for safety information.

Refer to Systems Operation, Testing and Adjusting, "Cleanliness of Fuel System Components" for detailed information on the standards of cleanliness that must be observed during ALL work on the fuel system.

Note: Ensure that the tools are stored with the caps in place. Store the tools in a clean plastic bag.

1. Ensure that the fuel level in the fuel tank is above the level of the suction pipe in the fuel tank.
2. Inspect the fuel system thoroughly for leaks. If necessary, repair the fuel system.
3. Check all low-pressure fuel lines from the fuel tank for restrictions. Replace any damaged components.
4. Prime the fuel system. Refer to Operation and Maintenance Manual, "Fuel System - Prime" for the correct procedure. If the electric fuel transfer pump is not operating, refer to Troubleshooting, "Fuel Pump Relay Circuit - Test".
5. Start the engine. Refer to Operation and Maintenance Manual, "Starting the Engine" for the correct procedure. Check if the problem has been resolved. Run the engine at low idle speed for 5 minutes.
6. Stop the engine. Refer to Operation and Maintenance Manual, "Stopping the Engine" for the correct procedure.

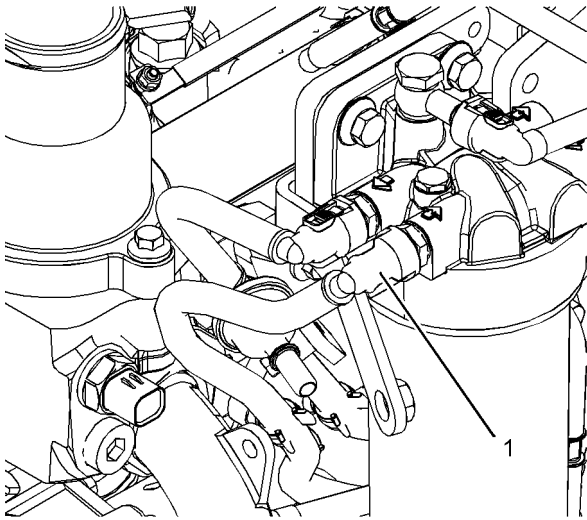

Illustration 59

g02305093

Typical example

7. If necessary, remove the low-pressure fuel line from the retaining clips. Remove the low-pressure fuel line from the inlet connection (1) of the secondary fuel filter base.

Note: Ensure that the low-pressure fuel lines are not deformed.

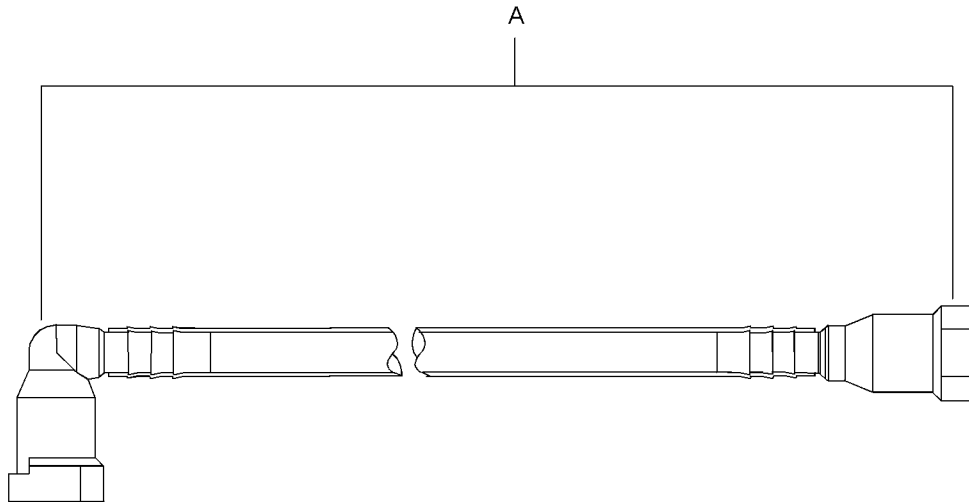

Illustration 60

g02352952

8. Connect Tooling (A) to the low-pressure fuel line and the secondary fuel filter base. Connect the open end of the tube to the inlet connection (1) of the secondary fuel filter base. Ensure that Tooling (A) is secured and clear of rotating parts.
9. Prime the fuel system. Refer to Operation and Maintenance Manual, "Fuel System - Prime" for the correct procedure.
10. Start the engine. Refer to Operation and Maintenance Manual, "Starting the Engine" for the correct procedure. Refer to steps 10.a to 10.d for the procedure for testing the air in fuel.

- a. Run the engine a low idle speed.
- b. Run the engine for 2 minutes. There should be no air in the fuel flow through the sight tube. Small bubbles that are spaced more than 2.5 cm (1.0 inch) are acceptable. Do not manipulate the connections during the test for the air in fuel.
- c. The presence of large bubbles or a continuous stream of bubbles indicates a leak.
- d. Investigate potential leaks and rectify any potential leaks in the low-pressure fuel system. Check for leaks in the connections of the inline fuel strainer. Check for leaks between the fuel tank and the inlet at the fuel transfer pump. If necessary, replace the low-pressure fuel lines.

11. Remove Tooling (A). Reconnect the low-pressure lines.

12. Prime the fuel system. Refer to Operation and Maintenance Manual, "Fuel System - Prime" for the correct procedure.

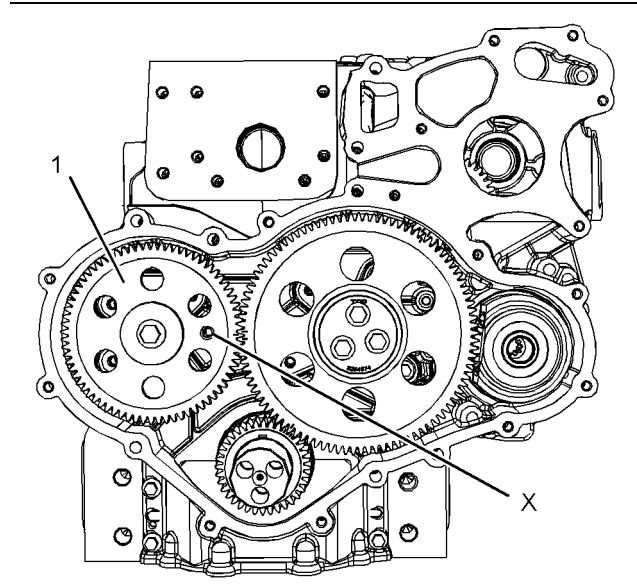

Illustration 61
Typical example

g01907734

i04316323

Finding Top Center Position for No. 1 Piston

SMCS Code: 1105-531

Table 2

Required Tools			
Tool	Part Number	Part Description	Qty
A ⁽¹⁾	9U-6198	Crankshaft Turning Tool	1
A ⁽²⁾	5P-7306	Housing	1
	5P-7305	Engine Turning Tool	1
B	230-6284	Timing Pin (Camshaft)	1
C	136-4632	Timing Pin (Crankshaft)	1

(1) The Crankshaft Turning Tool is used on the front pulley.

(2) This Tool is used in the aperture for the electric starting motor.

Note: Either Tooling (A) can be used. Use the Tooling that is most suitable.

1. Remove the front cover. Refer to Disassembly and Assembly, "Front Cover - Remove and Install".

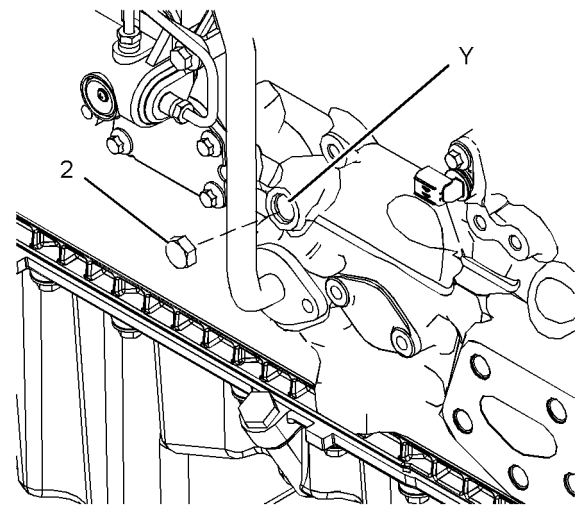

Illustration 62
Typical example

g01907735

2. Use Tooling (A) in order to rotate the crankshaft until the Hole (X) in the camshaft gear (1) aligns with the hole in the front housing. Refer to illustration 61. Remove the plug (2) from the cylinder block. Install Tooling (C) into the Hole (Y) in the cylinder block. Use Tooling (C) in order to lock the crankshaft in the correct position.

Note: Do not use excessive force to install Tooling (C). Do not use Tooling (C) to hold the crankshaft during repairs.

3. Install Tooling (B) through the hole (X) in the camshaft gear (1) into the front housing. Use Tooling (B) in order to lock the camshaft in the correct position.

i04139589

Fuel Injection Timing - Check

SMCS Code: 1251-036

Table 3

Required Tools			
Tool	Part Number	Part Description	Qty
A ⁽¹⁾	9U-6198	Crankshaft Turning Tool	1
A ⁽²⁾	5P-7306	Housing	1
	5P-7305	Engine Turning Tool	1
B	136-4632	Timing Pin (Crankshaft)	1
C	364-9107	Timing Pin (Fuel Injection Pump)	1

⁽¹⁾ The Crankshaft Turning Tool is used on the front pulley.

⁽²⁾ This Tool is used in the aperture for the electric starting motor.

NOTICE

Ensure that all adjustments and repairs that are carried out to the fuel system are performed by authorized personnel that have the correct training.

Before beginning ANY work on the fuel system, refer to Operation and Maintenance Manual, "General Hazard Information and High Pressure Fuel Lines" for safety information.

Refer to Systems Operation, Testing and Adjusting, "Cleanliness of Fuel System Components" for detailed information on the standards of cleanliness that must be observed during ALL work on the fuel system.

This procedure must be done before any of the following:

- Removal of the fuel injection pump.
 - The bolts that hold the fuel injection pump to the front housing are loosened.
1. If necessary, install the fuel injection pump. Refer to Disassembly and Assembly, "Fuel Injection Pump - Install" for the correct procedure.

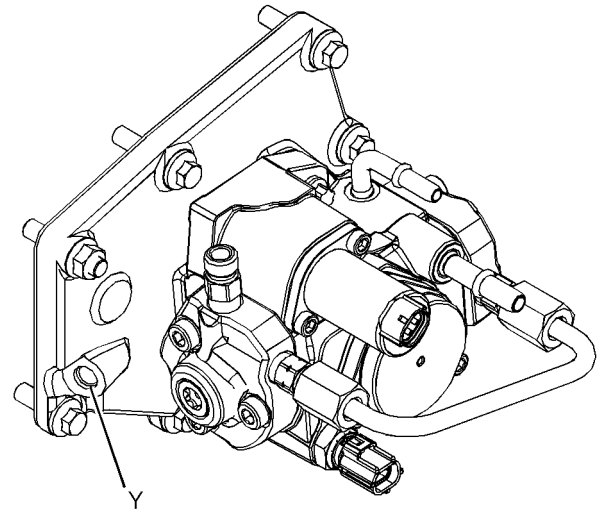

Illustration 63
Typical example

g02337216

2. Install Tooling (C) into hole in adapter plate at Position (Y). Use Tooling (A) to rotate the crankshaft until Tooling (C) locates into the slot in the gear for the fuel injection pump.

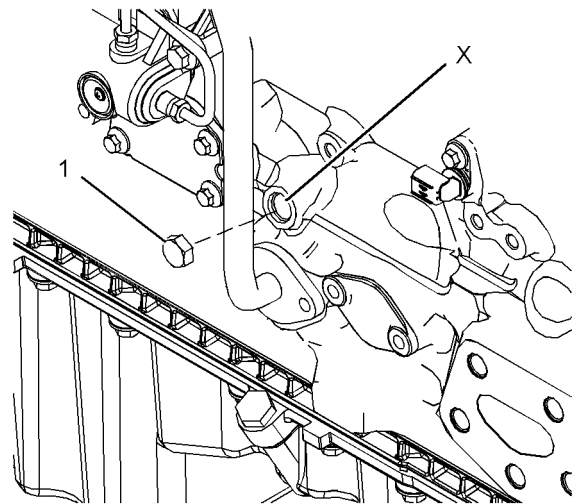

Illustration 64
Typical example

g01958182

3. Remove plug (1) from the cylinder block. If necessary, use Tooling (A) in order to rotate the crankshaft until the number one piston is at the top center position.

Note: The number one piston may be on the compression stroke or the exhaust stroke.

4. Install Tooling (B) into Hole (X) in the cylinder block. Use Tooling (B) in order to locate the crankshaft in the correct position.

Note: Do not use excessive force to install Tooling (B). Do not use Tooling (B) to hold the crankshaft during repairs.

5. Remove Tooling (C) from the adapter plate.
6. Remove Tooling (B) from the cylinder block.

i04026058

Fuel Quality - Test

SMCS Code: 1280-081

Note: Refer to **Systems Operation, Testing and Adjusting, “Cleanliness of Fuel System Components”** for detailed information on the standards of cleanliness that must be observed during **ALL work on the fuel system.**

Ensure that all adjustments and repairs are performed by authorized personnel that have had the correct training.

Use the following procedure to test for problems regarding fuel quality:

1. Determine if water and/or contaminants are present in the fuel. Check the water separator. Drain the water separator, if necessary. A full fuel tank minimizes the potential for overnight condensation.

Note: A water separator can appear to be full of fuel when the water separator is full of water.

2. Determine if contaminants are present in the fuel. Remove a sample of fuel from the bottom of the fuel tank. Visually inspect the fuel sample for contaminants. The color of the fuel is not necessarily an indication of fuel quality. However, fuel that is black, brown, and/or like sludge can be an indication of the growth of bacteria or oil contamination. In cold temperatures, cloudy fuel indicates that the fuel may not be suitable for operating conditions.

Refer to Operation and Maintenance Manual, “Fuel Recommendations” for more information.

3. If fuel quality is still suspected as a possible cause to problems regarding engine performance, disconnect the fuel inlet line. Temporarily operate the engine from a separate source of fuel that is known to be good. This will determine if the problem is caused by fuel quality. If fuel quality is determined to be the problem, drain the fuel system and replace the fuel filters. Engine performance can be affected by the following characteristics:

- Cetane number of the fuel
- Viscosity of the fuel
- Lubricity of the fuel
- Air in the fuel
- Other fuel characteristics

Refer to Operation and Maintenance Manual, “Fuel Recommendations” for more information on the cetane number of the fuel.

i04081709

Fuel System - Prime

SMCS Code: 1258-548

Note: Refer to **Systems Operation, Testing, and Adjusting, “Cleanliness of Fuel System Components”** for detailed information on the standards of cleanliness that must be observed during **ALL work on the fuel system.**

Ensure that all adjustments and repairs are performed by authorized personnel that have had the correct training.

NOTICE

Do not crank the engine continuously for more than 30 seconds. Allow the starting motor to cool for two minutes before cranking the engine again.

If air enters the fuel system, the air must be purged from the fuel system before the engine can be started. Air can enter the fuel system when the following events occur:

- The fuel tank is empty or the fuel tank has been partially drained.
- The low-pressure fuel lines are disconnected.
- A leak exists in the low-pressure fuel system.
- The fuel filter has been replaced.

Use the following procedure in order to remove air from the fuel system:

i03578027

1. Ensure that the fuel system is in working order. Check that the fuel supply valve (if equipped) is in the "ON" position.
2. Turn the keyswitch to the "RUN" position.
3. The keyswitch will allow the electric priming pump to operate. Operate the electric priming pump for 2 minutes.
4. Turn the keyswitch to the "OFF" position. The fuel system should now be primed and the engine should be able to start.
5. Operate the engine starting motor and crank the engine. After the engine has started, operate the engine at low idle for a minimum of 5 minutes. Ensure that the fuel system is free from leaks.

Note: Operating the engine for this period will help ensure that the fuel system is free of air. **DO NOT loosen the high-pressure fuel lines in order to purge air from the fuel system. This procedure is not required.**

After the engine has stopped, you must wait for 10 minutes in order to allow the fuel pressure to be purged from the high-pressure fuel lines before any service or repair is performed on the engine fuel lines. If necessary, perform minor adjustments. Repair any leaks from the low-pressure fuel system and from the cooling, lubrication, or air systems. Replace any high-pressure fuel line that has leaked. Refer to Disassembly and Assembly, "Fuel Injection Lines - Install".

If you inspect the engine in operation, always use the proper inspection procedure in order to avoid a fluid penetration hazard. Refer to Operation and Maintenance Manual, "General hazard Information".

If the engine will not start, refer to Troubleshooting, "Engine Cranks but will not Start".

Gear Group (Front) - Time

SMCS Code: 1206-531

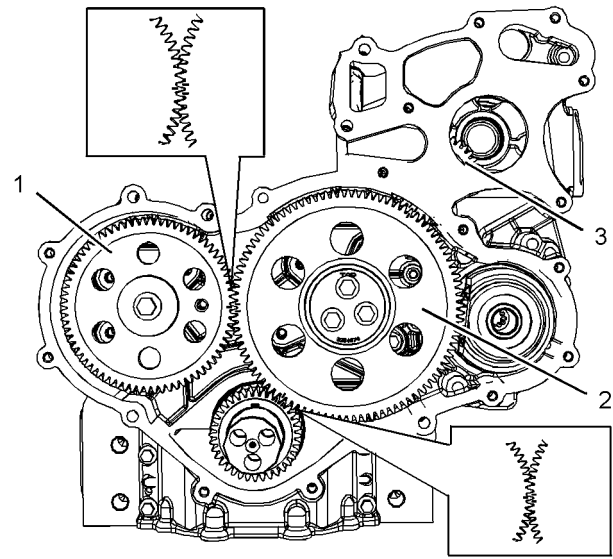

Illustration 65

g01907773

Typical example

- (1) Camshaft gear
- (2) Idler gear
- (3) Fuel Injection Pump gear

1. Install the camshaft gear (1) onto the camshaft. Refer to Disassembly and Assembly, "Camshaft Gear - Remove and Install" for the correct procedure.
2. Ensure that the crankshaft and the camshaft are locked in the correct position. Refer to Systems Operation, Testing and Adjusting, "Finding Top Center Position for No. 1 Piston" for the correct procedure. Ensure that the fuel injection pump is locked in the correct position. Refer to Disassembly and Assembly, "Fuel Injection Pump - Remove" for the correct procedure.
3. Install the idler gear (2). Refer to Disassembly and Assembly, "Idler Gear - Remove and Install" for the correct procedure.
4. Install the fuel injection pump and gear assembly (3). Refer to Disassembly and Assembly, "Fuel Injection Pump - Install" for the correct procedure.
5. Make sure that the timing marks on the gears (1), (2) and (3) are in alignment. If the timing marks are not aligned, refer to Disassembly and Assembly, "Gear Group (Front) - Remove and Install".

Air Inlet and Exhaust System

i03965393

Air Inlet and Exhaust System - Inspect

SMCS Code: 1050-040

A general visual inspection should be made to the air inlet and exhaust system. Make sure that there are no signs of leaks in the system.

There will be a reduction in the performance of the engine if there is a restriction in the air inlet system or the exhaust system.

WARNING

Hot engine components can cause injury from burns. Before performing maintenance on the engine, allow the engine and the components to cool.

WARNING

Making contact with a running engine can cause burns from hot parts and can cause injury from rotating parts.

When working on an engine that is running, avoid contact with hot parts and rotating parts.

1. Inspect the engine air cleaner inlet and ducting in order to ensure that the passageway is not blocked or collapsed.
2. Inspect the engine air cleaner element. Replace a dirty engine air cleaner element with a clean engine air cleaner element. Refer to Operation and Maintenance Manual, "Engine Air Cleaner Element (Dual Element) - Clean/Replace" or Operation and Maintenance Manual, "Engine Air Cleaner Element (Single Element) - Replace" for the correct procedure.
3. Check for dirt tracks on the clean side of the engine air cleaner element. If dirt tracks are observed, contaminants are flowing past the engine air cleaner element and/or the seal for the engine air cleaner element.

Inspection of the Crankcase Breather

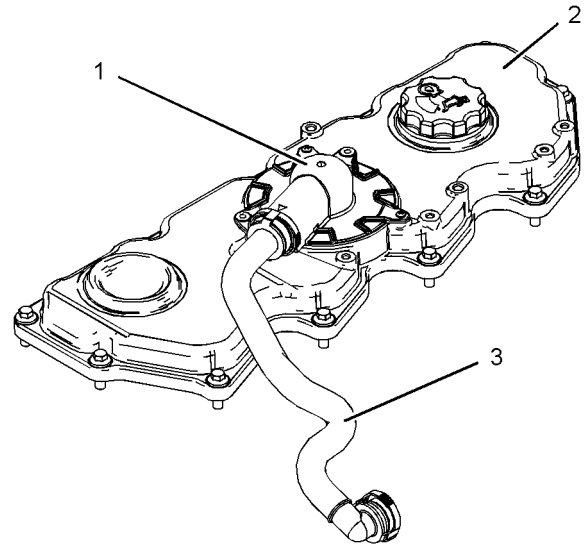

Illustration 66

g02161629

Typical example

- (1) Separator
- (2) Valve mechanism cover
- (3) Breather tube

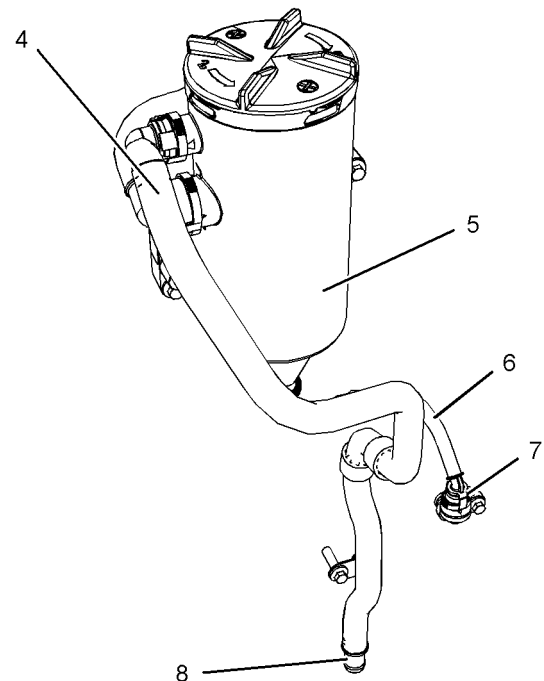

Illustration 67

g02161630

Typical example

- (4) Breather tube
- (5) Breather assembly
- (6) Drain tube
- (7) One way valve
- (8) Outlet

If the filter for the crankcase breather becomes blocked, the pressure relief valve will operate. The pressure relief valve will also operate if there is a blockage in the system.

A general visual inspection should be made of the crankcase breather. To indicate that the pressure relief valve for the crankcase breather has been in operation, the following issues will be seen. These issues are found behind the breather canister.

- Smearing of the oil
 - Droplets of oil
 - Wet patches of oil
1. Check the element for the engine crankcase breather. If necessary, replace the element for the crankcase breather. Refer to Operation and Maintenance Manual, "Engine Crankcase Breather Element - Replace".
 2. If there is sludge or debris in the canister, remove the canister. Refer to Disassembly and Assembly, "Crankcase Breather - Remove and Install". Clean the inside of the canister. Check that the gas inlet, the outlet connections, and the connections for the oil drain are clear.
 - a. Remove the breather hoses and visually check the insides for signs of blockage and check with low-pressure air. If necessary, clean the hoses.
 - b. If necessary, replace the element for the crankcase breather. Refer to Operation and Maintenance Manual, "Engine Crankcase Breather Element - Replace".
 - c. Install the canister and hoses. Refer to Disassembly and Assembly, "Crankcase Breather - Remove and Install".
 3. Check that the outlet for the crankcase breather is clean and free of obstructions. Ice can cause an obstruction in adverse weather conditions.

If excessive crankcase pressure is experienced and the pressure relief valve for the crankcase breather has not activated, there could be a blockage in the valve mechanism cover.

1. Remove the valve mechanism cover. Refer to Disassembly and Assembly, "Valve Mechanism Cover - Remove and Install" for the correct procedure.
2. Inspect the inside of the valve cover for debris. The separator for the oil in the cover must be inspected. Ensure that all debris is removed from the cover.

Note: Do not attempt to remove the separator from the cover. The separator can be cleaned if the separator is still attached to the cover.

i04302733

Turbocharger - Inspect (Series Turbochargers)

SMCS Code: 1052-040

WARNING

Hot engine components can cause injury from burns. Before performing maintenance on the engine, allow the engine and the components to cool.

NOTICE

Keep all parts clean from contaminants.

Contaminants may cause rapid wear and shortened component life.

NOTICE

Care must be taken to ensure that fluids are contained during performance of inspection, maintenance, testing, adjusting and repair of the product. Be prepared to collect the fluid with suitable containers before opening any compartment or disassembling any component containing fluids.

Dispose of all fluids according to local regulations and mandates.

Before you begin inspection of the turbocharger, be sure that the inlet air restriction is within the specifications for your engine. Be sure that the exhaust system restriction is within the specifications for your engine. Refer to Systems Operation, Testing, and Adjusting, "Air Inlet and Exhaust System - Inspect".

The condition of the turbocharger will have definite effects on engine performance. Use the following inspections and procedures to determine the condition of the turbocharger.

- Inspection of the compressor and the compressor housing
- Inspection of the turbine wheel and the turbine housing
- Inspection of the wastegate

Inspection of the Compressor and the Compressor Housing

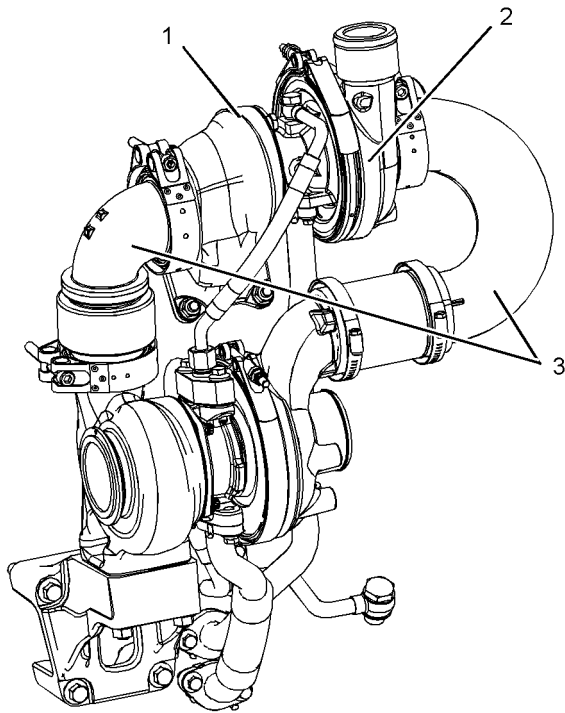

Illustration 68

g02466996

Typical example

- (1) Turbine housing
- (2) Compressor housing
- (3) Ducts

1. Inspect the compressor wheel and the ducts for damage from a foreign object. The ducts can be removed. If there is damage, determine the source of the foreign object. Replace the turbocharger. If there is no damage, go to step 2.
2. Turn the rotating assembly by hand. While you turn the assembly, push the assembly sideways. The assembly should turn freely. The compressor wheel should not rub the compressor housing. The turbocharger must be replaced if the compressor wheel rubs the compressor wheel housing. If there is no rubbing or scraping, go to step 3.
3. Inspect the compressor and the compressor wheel housing for oil leakage. An oil leak from the compressor may deposit oil in the aftercooler. If oil is found in the aftercooler, then drain and clean the aftercooler.
 - a. Check the oil level in the crankcase. If the oil level is too high, adjust the oil level.

- b. Inspect the engine air cleaner element. Replace a dirty engine air cleaner element with a clean engine air cleaner element. Refer to Operation and Maintenance Manual, "Engine Air Cleaner Element (Dual Element) - Clean/Replace" or Operation and Maintenance Manual, "Engine Air Cleaner Element (Single Element) - Replace" for the correct procedure. Inspect the engine air cleaner service indicator. Refer to Operation and Maintenance Manual, "Engine Air Cleaner Service Indicator - Inspect" for the correct procedure.
- c. Inspect the engine crankcase breather. Clean the engine crankcase breather or replace the engine crankcase breather if the engine crankcase breather is plugged.
- d. Remove the pipe for the oil drain. Inspect the drain opening. Inspect the oil drain line. Inspect the area between the bearings of the rotating assembly shaft. Look for oil sludge. Inspect the oil drain hole for oil sludge. Inspect the oil drain line for oil sludge in the drain line. If necessary, clean the oil drain line. Replace the oil drain line if there is any sign of damage to the oil drain line.
- e. Inspect the back pressure valve for visual damage. Check that the exposed spring and lever mechanism is free from mud and debris. The operation of the back pressure valve can be checked by turning the keyswitch to the RUN position and then to the OFF position. This will drive the back pressure valve to the CLOSED position for approximately one second and return the back pressure valve to the OPEN position. This motion is visible from the exposed spring and lever mechanism.
- f. If steps 3.a through 3.e did not reveal the source of the oil leakage, the turbocharger has internal damage. Replace the turbocharger.

Inspection of the Turbine Wheel and the Turbine Housing

Remove the air piping from the turbine housing.

1. Inspect the turbine for damage by a foreign object. If there is damage, determine the source of the foreign object. Replace the turbocharger. If there is no damage, go to step 2.
2. Inspect the turbine wheel for the carbon and other foreign material. Inspect turbine housing (1) for carbon and foreign material. Replace the turbocharger, if necessary. If there is no buildup of carbon or foreign material, go to step 3.

3. Turn the rotating assembly by hand. While you turn the assembly, push the assembly sideways. The assembly should turn freely. The turbine wheel should not rub turbine wheel housing (1). Replace the turbocharger if turbine wheel rubs turbine housing (1). If there is no rubbing or scraping, go to step 4.
4. Inspect the turbine and turbine housing (1) for oil leakage. Inspect the turbine and turbine housing (1) for oil coking. Some oil coking may be cleaned. Heavy oil coking may require replacement of the turbocharger. If the oil is coming from the turbocharger center housing go to step 4.a. Otherwise go to "Inspection of the Wastegate".
 - a. Remove the pipe for the oil drain. Inspect the drain opening. Inspect the area between the bearings of the rotating assembly shaft. Look for oil sludge. Inspect the oil drain hole for oil sludge. Inspect the oil drain line for oil sludge. If necessary, clean the drain line.
 - b. If crankcase pressure is high, or if the oil drain is restricted, pressure in the center housing may be greater than the pressure of turbine housing (1). Oil flow may be forced in the wrong direction and the oil may not drain. Check the crankcase pressure and correct any problems.
 - c. If the oil drain line is damaged, replace the oil drain line.
 - d. Check the routing of the oil drain line. Eliminate any sharp restrictive bends. Make sure that the oil drain line is not too close to the engine exhaust manifold.
 - e. If steps 4.a through 4.d did not reveal the source of the oil leakage, turbocharger (3) has internal damage. Replace the turbocharger.

Inspection of the Wastegate

The wastegate actuator controls the amount of exhaust gas that is allowed to bypass the turbine side of the turbocharger. This valve then controls the rpm of the turbocharger.

When the engine operates in conditions of a low boost (lug), a spring presses against a diaphragm in the canister. The load on the spring holds the wastegate closed. The turbocharger can then operate at maximum performance.

When a boost pressure signal acts against the diaphragm in the wastegate actuator, the pressure overcomes the spring and the wastegate will open. The rpm of the turbocharger becomes limited. The rpm limitation occurs because a portion of the exhaust gases bypass the turbine wheel of the turbocharger.

The following levels of boost pressure indicate a potential problem with the wastegate actuator or wastegate regulator:

- Too high at full load conditions
- Too low at all lug conditions

The boost pressure controls the maximum rpm of the turbocharger, which controls the position of the wastegate. The following factors also affect the maximum rpm of the turbocharger:

- The engine rating
- The power demand on the engine
- The high idle rpm
- Inlet air restriction
- Exhaust system restriction

Note: Check the operation of the wastegate regulator. Refer to Troubleshooting, "Solenoid Valve - Test".

Check the Wastegate for Proper Operation

Table 4

Required Tools			
Tool	Part Number	Part Description	Qty
A	8T-5096	Dial Indicator Group	1

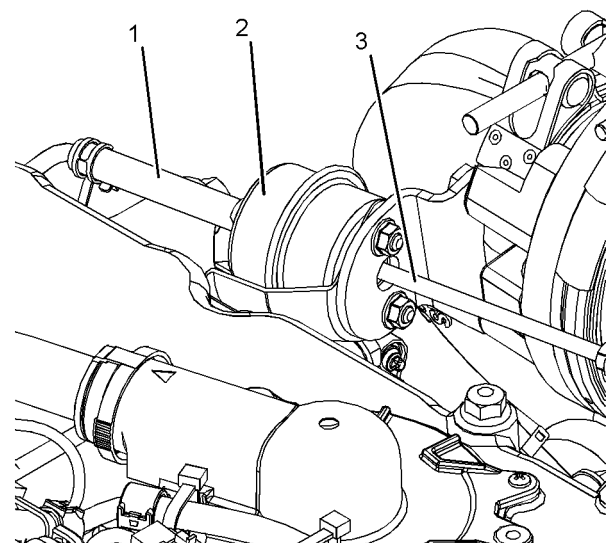

Illustration 69
Typical example

g02466997

Note: The wastegate actuator is installed to the high-pressure turbocharger.

1. Disconnect the pipe for the boost sensor (1) at the wastegate actuator (2). Connect an air supply to the wastegate actuator that can be adjusted accurately.
2. Install Tooling (A) to the turbocharger so that the end of the actuator rod (3) is in contact with Tooling (A). This will measure axial movement of the actuator rod (3).
3. Slowly apply air pressure to the wastegate so that the actuator rod (3) moves 1.0 mm (0.039 inch). Refer to Specifications, "Turbocharger" for the correct pressure for the wastegate. Ensure that the dial indicator returns to zero when the air pressure is released. Repeat the test several times. This will ensure that an accurate reading is obtained.
4. If the operation of the wastegate is not correct, the turbocharger will need to be replaced.
5. Repeat steps 2 to 3 in order to repeat the pressure test.
6. If the air pressure is correct, remove the air supply. Remove Tooling (A). Install the pipe for the boost sensor (1).

i04121429

Turbocharger - Inspect (Single Turbocharger)

SMCS Code: 1052-040

WARNING

Hot engine components can cause injury from burns. Before performing maintenance on the engine, allow the engine and the components to cool.

NOTICE

Keep all parts clean from contaminants.

Contaminants may cause rapid wear and shortened component life.

NOTICE

Care must be taken to ensure that fluids are contained during performance of inspection, maintenance, testing, adjusting and repair of the product. Be prepared to collect the fluid with suitable containers before opening any compartment or disassembling any component containing fluids.

Dispose of all fluids according to local regulations and mandates.

Before you begin inspection of the turbocharger, be sure that the inlet air restriction is within the specifications for your engine. Be sure that the exhaust system restriction is within the specifications for your engine. Refer to Systems Operation, Testing, and Adjusting, "Air Inlet and Exhaust System - Inspect".

The condition of the turbocharger will have definite effects on engine performance. Use the following inspections and procedures to determine the condition of the turbocharger.

- Inspection of the compressor and the compressor housing
- Inspection of the turbine wheel and the turbine housing
- Inspection of the wastegate

Inspection of the Compressor and the Compressor Housing

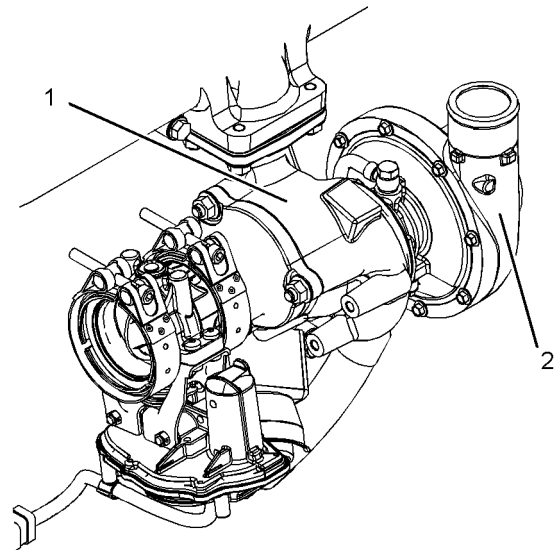

Illustration 70

g02334196

Typical example

- (1) Turbine housing
- (2) Compressor housing

1. Inspect the compressor wheel for damage from a foreign object. If there is damage, determine the source of the foreign object. Replace the turbocharger. If there is no damage, go to step 2.
2. Turn the rotating assembly by hand. While you turn the assembly, push the assembly sideways. The assembly should turn freely. The compressor wheel should not rub the compressor housing. The turbocharger must be replaced if the compressor wheel rubs the compressor wheel housing. If there is no rubbing or scraping, go to step 3.

3. Inspect the compressor and the compressor wheel housing for oil leakage. An oil leak from the compressor may deposit oil in the aftercooler. If oil is found in the aftercooler, then drain and clean the aftercooler.
 - a. Check the oil level in the crankcase. If the oil level is too high, adjust the oil level.
 - b. Inspect the engine air cleaner element. Replace a dirty engine air cleaner element with a clean engine air cleaner element. Refer to Operation and Maintenance Manual, "Engine Air Cleaner Element (Dual Element) - Clean/Replace" or Operation and Maintenance Manual, "Engine Air Cleaner Element (Single Element) - Replace" for the correct procedure. Inspect the engine air cleaner service indicator. Refer to Operation and Maintenance Manual, "Engine Air Cleaner Service Indicator - Inspect" for the correct procedure.
 - c. Inspect the engine crankcase breather. Clean the engine crankcase breather or replace the engine crankcase breather if the engine crankcase breather is plugged.
 - d. Remove the pipe for the oil drain. Inspect the drain opening. Inspect the oil drain line. Inspect the area between the bearings of the rotating assembly shaft. Look for the oil sludge. Inspect the oil drain hole for the oil sludge. Inspect the oil drain line for the oil sludge in the drain line. If necessary, clean the oil drain line. Replace the oil drain line if there is any sign of damage to the oil drain line.
 - e. Inspect the back pressure valve for visual damage. Check that the exposed spring and lever mechanism is free from mud and debris. The operation of the back pressure valve can be checked by turning the keyswitch to the RUN position and then to the OFF position. This will drive the back pressure valve to the CLOSED position for approximately one second and return the back pressure valve to the OPEN position. This motion is visible from the exposed spring and lever mechanism.
 - f. If steps 3.a through 3.e did not reveal the source of the oil leakage, the turbocharger has internal damage. Replace the turbocharger.
2. Inspect the turbine wheel for the carbon and other foreign material. Inspect turbine housing (1) for carbon and foreign material. Replace the turbocharger, if necessary. If there is no buildup of carbon or foreign material, go to step 3.
3. Turn the rotating assembly by hand. While you turn the assembly, push the assembly sideways. The assembly should turn freely. The turbine wheel should not rub turbine wheel housing (1). Replace the turbocharger if the turbine wheel rubs turbine housing (1). If there is no rubbing or scraping, go to step 4.
4. Inspect the turbine and turbine housing (1) for oil leakage. Inspect the turbine and turbine housing (1) for oil coking. Some oil coking may be cleaned. Heavy oil coking may require replacement of the turbocharger. If the oil is coming from the turbocharger center housing go to step 4.a. Otherwise go to "Inspection of the Wastegate".
 - a. Remove the pipe for the oil drain. Inspect the drain opening. Inspect the area between the bearings of the rotating assembly shaft. Look for the oil sludge. Inspect the oil drain hole for the oil sludge. Inspect the oil drain line for the oil sludge. If necessary, clean the drain line.
 - b. If crankcase pressure is high, or if the oil drain is restricted, pressure in the center housing may be greater than the pressure of turbine housing (1). Oil flow may be forced in the wrong direction and the oil may not drain. Check the crankcase pressure and correct any problems.
 - c. If the oil drain line is damaged, replace the oil drain line.
 - d. Check the routing of the oil drain line. Eliminate any sharp restrictive bends. Make sure that the oil drain line is not too close to the engine exhaust manifold.
 - e. If steps 4.a through 4.d did not reveal the source of the oil leakage, turbocharger (3) has internal damage. Replace the turbocharger.

Inspection of the Turbine Wheel and the Turbine Housing

Remove the air piping from the turbine housing.

1. Inspect the turbine for damage by a foreign object. If there is damage, determine the source of the foreign object. Replace the turbocharger. If there is no damage, go to step 2.

Inspection of the Wastegate

The wastegate actuator controls the amount of exhaust gas that is allowed to bypass the turbine side of the turbocharger. This valve then controls the rpm of the turbocharger.

When the engine operates in conditions of a low boost (lug), a spring presses against a diaphragm in the canister. The load on the spring holds the wastegate closed. The turbocharger can then operate at maximum performance.

When a boost pressure signal acts against the diaphragm in the wastegate, the pressure overcomes the spring and the wastegate actuator will open. The rpm of the turbocharger becomes limited. The rpm limitation occurs because a portion of the exhaust gases bypass the turbine wheel of the turbocharger.

The following levels of boost pressure indicate a potential problem with the wastegate actuator or wastegate regulator:

- Too high at full load conditions
- Too low at all lug conditions

The boost pressure controls the maximum rpm of the turbocharger, because the boost pressure controls the position of the wastegate. The following factors also affect the maximum rpm of the turbocharger:

- The engine rating
- The power demand on the engine
- The high idle rpm
- Inlet air restriction
- Exhaust system restriction

Note: Check the operation of the wastegate regulator. Refer to Troubleshooting, "Solenoid Valve - Test".

Check the Wastegate for Proper Operation

Table 5

Required Tools			
Tool	Part Number	Part Description	QTY
A	8T-5096	Dial Indicator Group	1

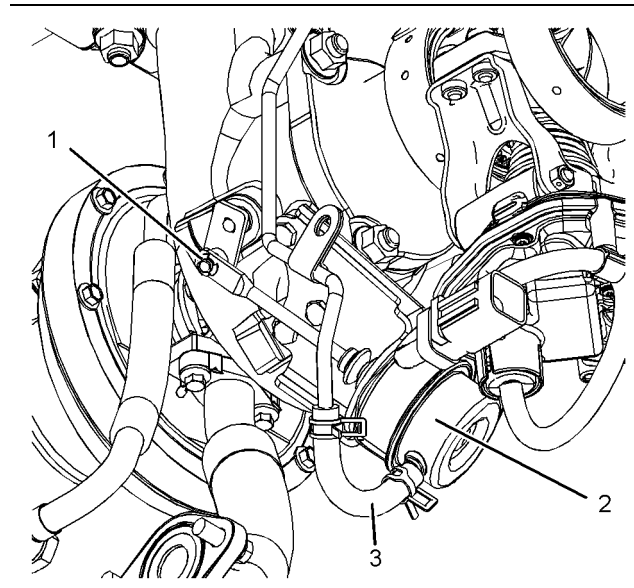

Illustration 71

g02334247

Typical example

1. Disconnect the pipe for the boost sensor (3) at the wastegate actuator (2). Connect an air supply to the wastegate actuator that can be adjusted accurately.
2. Install Tooling (A) to the turbocharger so that the end of the actuator rod (1) is in contact with Tooling (A). This will measure axial movement of the actuator rod (1).
3. Slowly apply air pressure to the wastegate so that the actuator rod (1) moves 1.0 mm (0.039 inch). Refer to Specifications, "Turbocharger" for the correct pressure for the wastegate. Ensure that the dial indicator returns to zero when the air pressure is released. Repeat the test several times. This will ensure that an accurate reading is obtained.
4. If the operation of the wastegate is not correct, the turbocharger will need to be replaced.
5. Repeat steps 2 to 3 in order to repeat the pressure test.
6. If the air pressure is correct, remove the air supply. Remove Tooling (A). Install the pipe for the boost sensor (3).

i04135749

Exhaust Cooler (NRS) - Test

SMCS Code: 1061; 1087; 108C-081

Table 6

Required Tools			
Tool	Part Number	Part Description	Qty
A	1U-5470	Engine Pressure Gp	1

Refer to Special Instruction, SEHS8907, "Using The 1U-5470 Engine Pressure Group".

Air Under Water Leak Test Procedure.

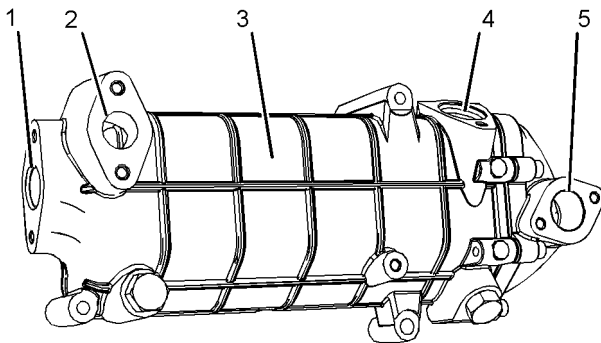

Illustration 72

g02424917

Typical example

1. Follow steps 1.a to 1.i in order to test the coolant side of the exhaust gas cooler (NRS).
 - a. Plug the coolant inlet (2) of the exhaust gas cooler (NRS) (3).
 - b. Plug the coolant outlet port (4) with tube and pressure regulator assembly.
 - c. Make sure that the air pressure regulator is closed and connect compressed air to the pressure regulator.
 - d. Use Tooling (A) in order to apply an air pressure of 250 kPa (36 psi) to the exhaust gas cooler (NRS).
 - e. While the exhaust gas cooler (NRS) is still pressurized, submerge the cooler in water that is at ambient temperature.
2. Follow steps 2.a to 2.i in order to test the gas side of the exhaust gas cooler (NRS).
 - a. Plug the gas inlet (5) of the exhaust gas cooler (NRS) (3).
 - b. Plug the gas outlet port (1) with tube and pressure regulator assembly.
 - c. Make sure that the air pressure regulator is closed and connect compressed air to the pressure regulator.
 - d. Use Tooling (A) in order to apply an air pressure of 250 kPa (36 psi) to the exhaust gas cooler (NRS).
 - e. While the exhaust gas cooler (NRS) is still pressurized, submerge the cooler in water that is at ambient temperature.
 - f. Allow the exhaust gas cooler (NRS) to settle in order for the air that is trapped to escape.
 - g. Observe the exhaust gas cooler (NRS) for air bubbles that indicate a leak. If air bubbles are seen within 3 minutes, this indicates a leak with the exhaust gas cooler (NRS). Note the location or the origin of the leak. Record this information.
 - h. If no bubbles are detected after 3 minutes, the exhaust gas cooler (NRS) is reusable.
 - i. Remove the exhaust gas cooler (NRS) from the water. If the exhaust gas cooler (NRS) does not leak, the problem may be elsewhere in the cooling system or the engine. Refer the service manual in order to check for leakage. If the exhaust gas cooler (NRS) does leak, the exhaust gas cooler (NRS) should be replaced.

i04027325

Compression - Test

SMCS Code: 1215

The cylinder compression test should only be used in order to compare the cylinders of an engine. If one or more cylinders vary by more than 350 kPa (51 psi), the cylinder and related components may need to be repaired.

A compression test should not be the only method which is used to determine the condition of an engine. Other tests should also be conducted in order to determine if the adjustment or the replacement of components is required.

Before the performance of the compression test, make sure that the following conditions exist:

- The battery is in good condition.
- The battery is fully charged.
- The starting motor operates correctly.
- The valve lash is correct.
- All glow plugs are removed.
- The ECM is powered.
- The fuel pressure sensor is connected.
- The suction control valve is connected.

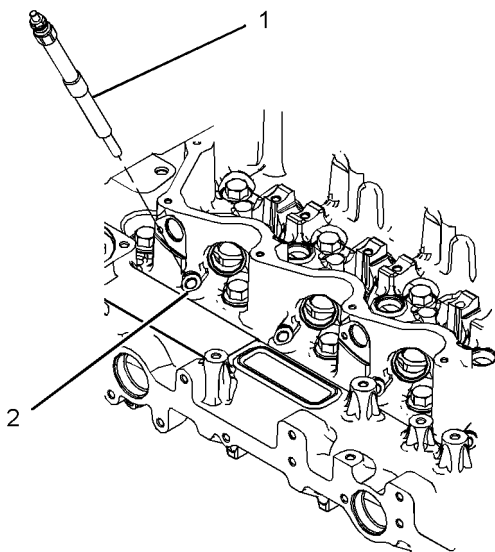

Illustration 73

g01925436

Typical example

1. Remove the glow plug (1). Refer to Disassembly and Assembly, "Glow Plugs - Remove and Install" for the correct procedure.

2. Install a suitable gauge for measuring the cylinder compression in the hole for the glow plug.
3. Remove the fuse for the glow plugs.
4. Operate the starting motor in order to turn the engine. Record the maximum pressure which is indicated on the compression gauge.
5. Repeat steps 2 and 4 for all cylinders.
6. Install the fuse for the glow plugs.

i04135693

Engine Valve Lash - Inspect

SMCS Code: 1102-040

Table 7

Required Tools			
Tool	Part Number	Part Description	Qty
A ⁽¹⁾	9U - 6198	Crankshaft Turning Tool	1
A ⁽²⁾	5P - 7306	Housing	1
	5P - 7305	Engine Turning Tool	1
B	136 - 4632	Timing Pin (Crankshaft)	1

(1) The Crankshaft Turning Tool is used on the front pulley.

(2) This Tool is used in the aperture for the electric starting motor.

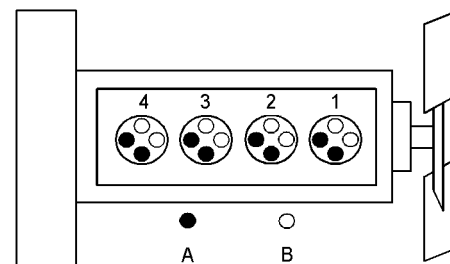

Illustration 74

g01335181

Cylinder and valve location

(A) Exhaust valve

(B) Inlet valve

Too much valve lash can cause some broken valve stems, springs, and spring retainers. Damage to the valve mechanism will produce emissions in excess of the correct specification.

The hydraulic lifter will compensate for all normal wear of the components of the valve train.

Too much valve lash can be an indication of the following problems:

- Worn camshaft and valve lifters
- Worn rocker arms
- Bent pushrods
- Broken socket on the upper end of a pushrod
- Loose adjustment screw for the valve lash
- Issues with the hydraulic lifters

If the camshaft and valve lifters show rapid wear, look for fuel in the lubrication oil or dirty lubrication oil as a possible cause.

Valve Lash Check

WARNING

Accidental engine starting can cause injury or death to personnel.

To prevent accidental engine starting, turn the ignition switch to the OFF position and place a do not operate tag at the ignition switch location.

1. Remove the valve mechanism cover. Refer to Disassembly and Assembly, "Valve Mechanism Cover - Remove and Install" for the correct procedure.

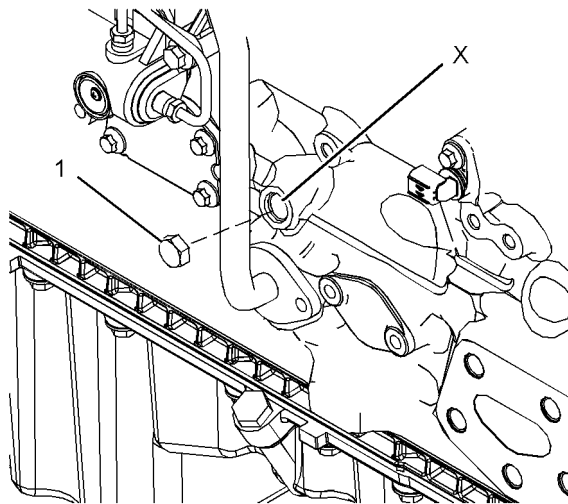

Illustration 75
Typical example

g01958182

2. Remove the plug (1) from the cylinder block. Use Tooling (A) to rotate the crankshaft until the number one piston is at the top center position.

Note: The number one piston may be on the compression stroke or the exhaust stroke.

3. Install Tooling (B) into the hole (X) in the cylinder block. Use Tooling (B) in order to locate the crankshaft in the correct position.

Note: Do not use excessive force to install Tooling (B). Do not use Tooling (B) to hold the crankshaft during repairs.

4. Check the rocker arms for an engine valve lash. There should be no engine valve lash.

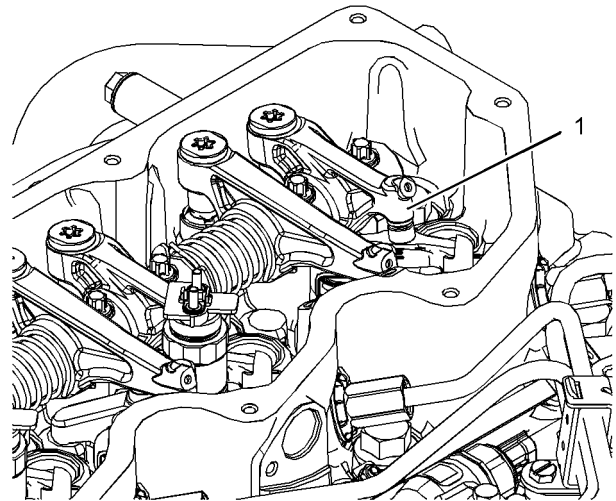

Illustration 76

g02333215

Typical example

One electronic unit injector is not shown for clarity.

5. If there is an engine valve lash at any position the engine valve lash may be caused by a normal leakdown of the hydraulic lifter. Push the affected rocker arm (1) against the pushrod. The rocker arm (1) should rotate as the pushrod is pushed up by the recovery of the hydraulic lifter. Once all motion has ceased test again for an engine valve lash. There should be no engine valve lash.
6. Remove Tooling (B) from the crankshaft. Use Tooling (A) to rotate the crankshaft in a clockwise direction. The crankshaft should be rotated 360 degrees. Install Tooling (B) to the crankshaft.
7. Check the rocker arms for an engine valve lash. There should be no engine valve lash.

8. If there is an engine valve lash at any position the engine valve lash may be caused by a normal leakdown of the hydraulic lifter. Push the affected rocker arm (1) against the pushrod. Monitor the rocker arm (1) for movement. The rocker arm (1) should rotate as the pushrod is pushed up by the recovery of the hydraulic lifter. Once all motion has ceased test again for an engine valve lash. There should be no engine valve lash.

9. If an engine valve lash is found in any position, examine the valve mechanism components for excessive wear or damage. This includes the hydraulic lifters.

i03996952

Valve Depth - Inspect

SMCS Code: 1105-040

Table 8

Required Tools			
Tool	Part Number	Part Description	Qty
A	8T-0455	Liner Projection Tool Group	1

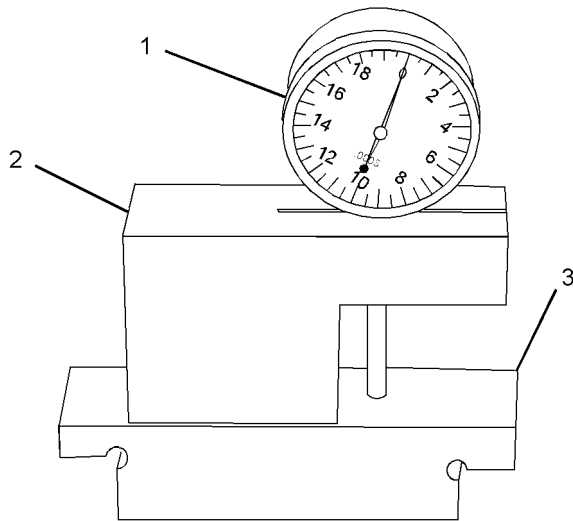

Illustration 77

g01343897

- (1) Dial indicator
- (2) Gauge body
- (3) Gauge block

1. Use the Tooling (A) to check the depths of the inlet valves and the exhaust valves below the face of the cylinder head. Use the gauge block (3) to zero the dial indicator (1).

2. Ensure that the face of the valves are clean. Ensure that the bottom face of the cylinder head is clean. Ensure that the cylinder head is not distorted. Refer to Testing and Adjusting, "Cylinder Head - Inspect" for the procedure to measure flatness of the cylinder head.

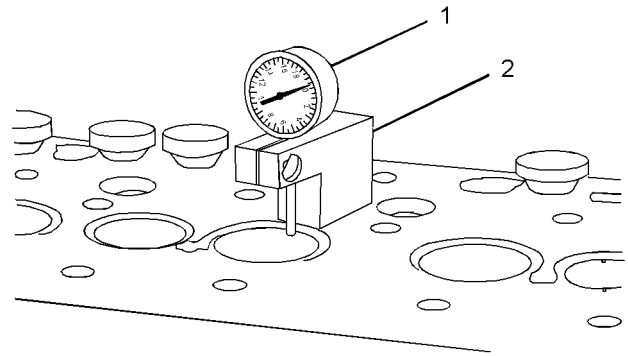

Illustration 78

g01343900

- Typical example
Measurement of the valve depth
- (1) Dial indicator
 - (2) Gauge body

3. Position gauge body (2) and dial indicator (1) in order to measure the valve depth. Measure the depth of the inlet valve and the exhaust valve before the valve springs are removed.
4. For the minimum and maximum limits for a new engine for the inlet valves and the exhaust valves, refer to Specifications, "Cylinder Head".
5. Service wear occurs on an engine which has been in operation. If the valve depth below the cylinder head face on a used engine exceeds the specification for service wear, the following components must be replaced.
 - Valves
 - Valve inserts

For the wear limits for the inlet valves and exhaust valves, refer to Specifications, "Cylinder Head".

6. Check each valve for cracks. Check the stems of the valves for wear. Ensure that the valves are the correct fit in the valve guides. Refer to Systems Operation, Testing and Adjusting, "Valve Guide - Inspect" for the procedure to inspect the valve guides.
7. Check the load on the valve springs. Refer to Specifications, "Cylinder Head Valves" for the correct lengths and specifications for the valve springs.

i03577785

Valve Guide - Inspect

SMCS Code: 1104-040

Perform this test in order to determine if a valve guide should be replaced.

The original valve guides are bored into the cylinder head. When new valve guides(1) are installed, new valves and new valve seat inserts must be installed. The cylinder head must be rebored in order to install the new valve guide. For more information, contact your distributor or your dealer.

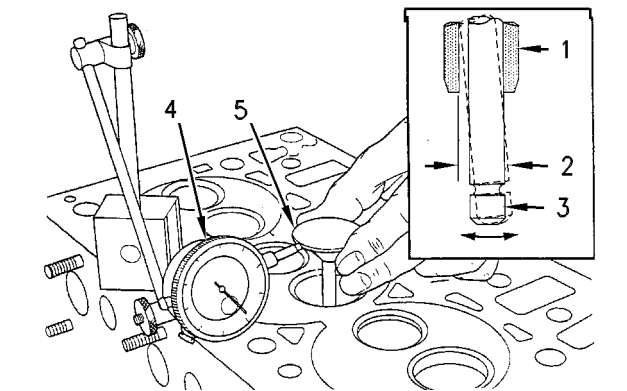

Illustration 79

g00314806

Measure the radial movement of the valve in the valve guide.

- (1) Valve guide
- (2) Radial movement of the valve in the valve guide
- (3) Valve stem
- (4) Dial indicator
- (5) Valve head

1. Place a new valve in the valve guide.
2. Place a dial indicator with a magnetic base on the face of the cylinder head.
3. Lift the edge of the valve head to a distance of 15.0 mm (0.60 inch).
4. Move the valve in a radial direction away from the dial indicator. Make sure that the valve moves away from the dial indicator as far as possible. Position the contact point of the dial indicator on the edge of the valve head. Set the position of the needle of the dial indicator to zero.
5. Move the valve in a radial direction toward the dial indicator as far as possible. Note the distance of movement which is indicated on the dial indicator. If the distance is greater than the maximum clearance of the valve in the valve guide, replace the valve guide.

The maximum clearance for the inlet valve stem in the valve guide with a valve lift of 15.0 mm (0.60 inch) is the following value. 0.26 mm (0.01024 inch)

The maximum clearance for the exhaust valve stem in the valve guide with a valve lift of 15.0 mm (0.60 inch) is the following value. 0.33 mm (0.01299 inch)

Lubrication System

i03994210

Engine Oil Pressure - Test

SMCS Code: 1304-081

Low Oil Pressure

The following conditions will cause low oil pressure.

- The oil level is low in the crankcase.
- A restriction exists on the oil suction screen.
- Connections in the oil lines are leaking.
- The connecting rod or the main bearings are worn.
- The rotors in the oil pump are worn.
- The oil pressure relief valve is operating incorrectly.

A worn oil pressure relief valve can allow oil to leak through the valve which lowers the oil pressure.

The minimum oil pressure at a maximum engine speed of 2200 rpm and at normal operating temperature is 280 kPa (40 psi). A lower pressure is normal at low idle.

A suitable pressure gauge can be used in order to test the pressure of the lubrication system.

High Oil Pressure

High oil pressure can be caused by the following conditions.

- The spring for the oil pressure relief valve is installed incorrectly.
- The plunger for the oil pressure relief valve becomes jammed in the closed position.
- Excessive sludge exists in the oil which makes the viscosity of the oil too high.

i03994211

Engine Oil Pump - Inspect

SMCS Code: 1304-040

If any part of the oil pump is worn enough in order to affect the performance of the oil pump, the oil pump must be replaced.

Perform the following procedures in order to inspect the oil pump. Refer to Specifications, "Engine Oil Pump" for clearances and torques.

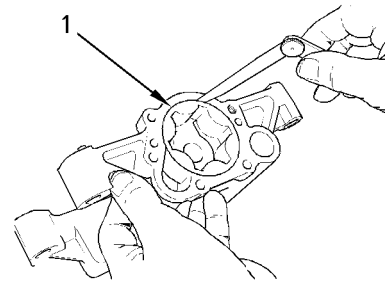

Illustration 80

g00938064

Typical example

1. Remove the oil pump from the engine. Remove the cover of the oil pump.
2. Remove the outer rotor (1). Clean all of the parts. Look for cracks in the metal or other damage.
3. Install the outer rotor. Measure the clearance of the outer rotor to the body .

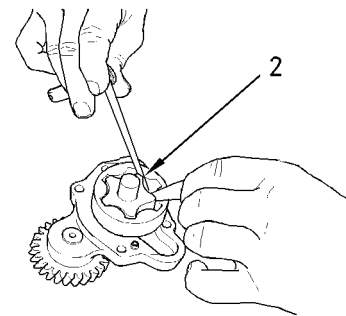

Illustration 81

g00938061

Typical example

4. Measure the clearance of the inner rotor to the outer rotor (2).

i02414692

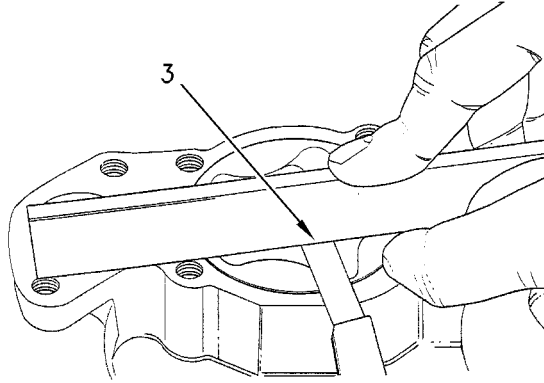

Illustration 82 g00938799

End play measurement of the rotor

5. Measure the end play of the outer rotor with a straight edge and a feeler gauge (3).
6. Clean the top face of the oil pump and the bottom face of the cover. Install the cover on the oil pump. Install the oil pump on the engine.

i04027269

Excessive Bearing Wear - Inspect

SMCS Code: 1203-040; 1211-040; 1219-040

When some components of the engine show bearing wear in a short time, the cause can be a restriction in an oil passage.

An engine oil pressure indicator may show that there is enough oil pressure, but a component is worn due to a lack of lubrication. In such a case, look at the passage for the oil supply to the component. A restriction in an oil supply passage will not allow enough lubrication to reach a component. Early wear will result.

Refer to Specifications for more information regarding component wear limits.

Excessive Engine Oil Consumption - Inspect

SMCS Code: 1348-040

Engine Oil Leaks on the Outside of the Engine

Check for leakage at the seals at each end of the crankshaft. Look for leakage at the gasket for the engine oil pan and all lubrication system connections. Look for any engine oil that may be leaking from the crankcase breather. This can be caused by combustion gas leakage around the pistons. A dirty crankcase breather will cause high pressure in the crankcase. A dirty crankcase breather will cause the gaskets and the seals to leak.

Engine Oil Leaks into the Combustion Area of the Cylinders

Engine oil that is leaking into the combustion area of the cylinders can be the cause of blue smoke. There are several possible ways for engine oil to leak into the combustion area of the cylinders:

- Failed valve stem seals
- Leaks between worn valve guides and valve stems
- Worn components or damaged components (pistons, piston rings, or dirty return holes for the engine oil)
- Incorrect installation of the compression ring and/or the intermediate ring
- Leaks past the seal rings in the turbocharger shaft
- Overfilling of the crankcase
- Wrong dipstick or guide tube
- Sustained operation at light loads

Excessive consumption of engine oil can also result if engine oil with the wrong viscosity is used. Engine oil with a thin viscosity can be caused by fuel leakage into the crankcase or by increased engine temperature.

i03577881

Increased Engine Oil Temperature - Inspect

SMCS Code: 1348-040

Look for a restriction in the oil passages of the oil cooler. The oil temperature may be higher than normal when the engine is operating. In such a case, the oil cooler may have a restriction.

Cooling System

i03578002

Cooling System - Check

SMCS Code: 1350-535

Engine And Cooling System Heat Problems

1. The following conditions indicate that a heat problem exists.
 - a. Hot coolant is released through the pressure cap during the normal operation of the engine. Hot coolant can also be released when the engine is stopped.
 - b. Hot coolant is released from the coolant system but not through the pressure cap during normal operation of the engine. Hot coolant can also be released when the engine is stopped.
 - c. Coolant must be added frequently to the cooling system. The coolant is not released through the pressure cap or through an outside leak.
2. If any of the conditions in Step 1 exist, perform the following procedures:
 - a. Run the engine at medium idle, which is approximately 1200 rpm, for three minutes after the high idle shuts off. Running the engine at medium idle will allow the engine to cool before the engine is stopped.
 - b. Inspect the poly v-belt for wear or for damage. If necessary, replace the poly v-belt. Refer to Disassembly and Assembly Manual, "Alternator Belt - Remove and Install" for the correct procedure.
3. Refer to "Visual Inspection Of The Cooling System" in order to determine if a leak exists in the cooling system.
 - a. Refer to "Testing The Radiator And Cooling System For Leaks" procedures.
4. If the coolant does not flow through the radiator and through other components of the cooling system, perform the following procedures.
 - a. Perform the "Testing The Water Temperature Regulator" procedures.

- b. Clean the radiator and other components with hot water or steam at low pressure. Detergent in the water may also be used. Compressed air may be used to remove materials from the cooling system. Identify the cause of the restriction before you choose the method for cleaning.
 - c. Straighten any fins of the radiator if the fins are bent.
5. Check the high idle of the engine. The engine may overheat if the high idle rpm is set too high.

i03577882

Cooling System - Inspect

SMCS Code: 1350-040

This engine has a pressure type cooling system. A pressure type cooling system gives two advantages:

- The pressure type cooling system can operate safely at a higher temperature than the boiling point of water at different atmospheric pressure ranges.
- The pressure type cooling system prevents cavitation in the water pump.

Cavitation is the sudden generation of low pressure bubbles in liquids by mechanical forces. The generation of an air or steam pocket is much more difficult in a pressure type cooling system.

Regular inspections of the cooling system should be made in order to identify problems before damage can occur. Visually inspect the cooling system before tests are made with the test equipment.

Visual Inspection Of The Cooling System

1. Check the coolant level in the cooling system.
2. Look for leaks in the system.

Note: A small amount of coolant leakage across the surface of the water pump seals is normal. This leakage is required in order to provide lubrication for this type of seal. A hole is provided in the water pump housing in order to allow this coolant/seal lubricant to drain from the pump housing. Intermittent leakage of small amounts of coolant from this hole is not an indication of water pump seal failure.

3. Inspect the radiator for bent fins and other restriction to the flow of air through the radiator.
 4. Inspect the drive belt for the fan.
 5. Inspect the blades of the fan for damage.

6. Look for air or combustion gas in the cooling system.
7. Inspect the radiator cap for damage. The sealing surface must be clean.
8. Look for large amounts of dirt in the radiator core. Look for large amounts of dirt on the engine.
9. Shrouds that are loose or missing cause poor air flow for cooling.

i03577960

Cooling System - Test

SMCS Code: 1350-040; 1350-081

Remember that temperature and pressure work together. When a diagnosis is made of a cooling system problem, temperature and pressure must be checked. The cooling system pressure will have an effect on the cooling system temperature. For an example, refer to Illustration 83. This will show the effect of pressure on the boiling point (steam) of water. This will also show the effect of height above sea level.

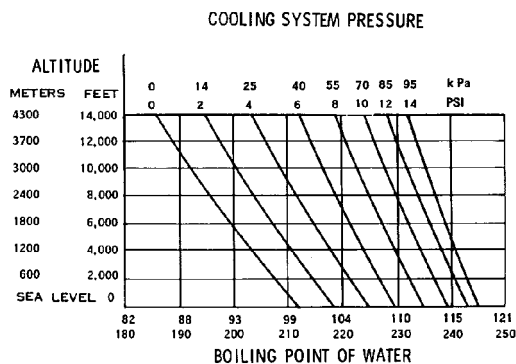

Illustration 83

g00286266

Cooling system pressure at specific altitudes and boiling points of water

WARNING

Personal injury can result from hot coolant, steam and alkali.

At operating temperature, engine coolant is hot and under pressure. The radiator and all lines to heaters or the engine contain hot coolant or steam. Any contact can cause severe burns.

Remove filler cap slowly to relieve pressure only when engine is stopped and radiator cap is cool enough to touch with your bare hand.

The coolant level must be to the correct level in order to check the coolant system. The engine must be cold and the engine must not be running.

After the engine is cool, loosen the pressure cap in order to relieve the pressure out of the cooling system. Then remove the pressure cap.

If the cooling system is equipped with a sight glass, the coolant should be to the correct level in the sight glass. On cooling systems without an indicator of the coolant level, fill the cooling system in order to be no more than 13 mm (0.5 inch) from the bottom of the filler pipe.

Making the Correct Antifreeze Mixtures

Do not add pure antifreeze to the cooling system in order to adjust the concentration of antifreeze. Refer to Operation and Maintenance Manual, "Refill Capacities" for the correct procedure. The pure antifreeze increases the concentration of antifreeze in the cooling system. The increased concentration increases the concentration of dissolved solids and undissolved chemical inhibitors in the cooling system.

The antifreeze mixture must consist of equal quantities of antifreeze and clean soft water. The corrosion inhibitor in the antifreeze will be diluted if a concentration of less than 50% of antifreeze is used. Concentrations of more than 50% of antifreeze may have the adverse effect on the performance of the coolant.

Checking the Filler Cap

One cause for a pressure loss in the cooling system can be a faulty seal on the radiator pressure cap.

WARNING

Personal injury can result from hot coolant, steam and alkali.

At operating temperature, engine coolant is hot and under pressure. The radiator and all lines to heaters or the engine contain hot coolant or steam. Any contact can cause severe burns.

Remove filler cap slowly to relieve pressure only when engine is stopped and radiator cap is cool enough to touch with your bare hand.

To check for the amount of pressure that opens the filler cap, use the following procedure:

1. After the engine cools, carefully loosen the filler cap. Slowly release the pressure from the cooling system. Then, remove the filler cap.

2. Carefully inspect the filler cap. Look for any damage to the seals and to the sealing surface. Inspect the following components for any foreign substances:
 - Filler cap
 - Seal
 - Surface for sealRemove any deposits that are found on these items, and remove any material that is found on these items.
3. Install the pressure cap onto a suitable pressurizing pump.
4. Observe the exact pressure that opens the filler cap.
5. Compare the pressure to the pressure rating that is found on the top of the filler cap. The pressure cap should open within 95 to 110 kPa (13.7788 to 15.9544 psi). The pressure cap has a nominal pressure rating of 100 kPa (14.504 psi).
6. If the filler cap is damaged, replace the filler cap.

Testing The Radiator And Cooling System For Leaks

Use the following procedure to test the radiator and the cooling system for leaks.

WARNING

Personal injury can result from hot coolant, steam and alkali.

At operating temperature, engine coolant is hot and under pressure. The radiator and all lines to heaters or the engine contain hot coolant or steam. Any contact can cause severe burns.

Remove filler cap slowly to relieve pressure only when engine is stopped and radiator cap is cool enough to touch with your bare hand.

1. When the engine has cooled, loosen the filler cap to the first stop. Allow the pressure to release from the cooling system. Then remove the filler cap.
2. Make sure that the coolant covers the top of the radiator core.
3. Put a suitable pressurizing Pump onto the radiator.
4. Use the pressurizing pump to increase the pressure to an amount of 20 kPa (3 psi) more than the operating pressure of the filler cap.

5. Check the radiator for leakage on the outside.
6. Check all connections and hoses of the cooling system for leaks.

The radiator and the cooling system do not have leakage if all of the following conditions exist:

- You do NOT observe any leakage after five minutes.
- The dial indicator remains constant beyond five minutes.

The inside of the cooling system has leakage only if the following conditions exist:

- The reading on the gauge goes down.
- You do NOT observe any outside leakage.

Make any repairs, as required.

i03907822

Engine Oil Cooler - Inspect

SMCS Code: 1378-040

WARNING

Hot oil and hot components can cause personal injury. Do not allow hot oil or hot components to contact the skin.

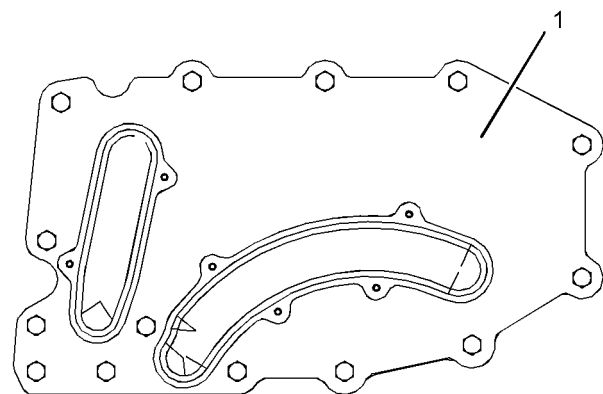

Illustration 84

g02148936

Typical example

Perform the following procedure in order to inspect the engine oil cooler.

1. Place a container under the oil cooler in order to collect any engine oil or coolant that drains from the oil cooler.
2. Refer to Disassembly and Assembly, "Engine Oil Cooler - Remove" for removal of the engine oil cooler.
3. Thoroughly clean the oil cooler (1) and the cylinder block.

WARNING

Personal injury can result from air pressure.

Personal injury can result without following proper procedure. When using pressure air, wear a protective face shield and protective clothing.

Maximum air pressure at the nozzle must be less than 205 kPa (30 psi) for cleaning purposes.

4. Inspect the oil cooler (1) for cracks and dents. Replace the oil cooler (1) if cracks or dents exist. Ensure that no restrictions for the flow of lubricating oil exist in the oil cooler (1).

Dry the oil cooler (1) with low-pressure air. Flush the inside of the oil cooler (1) with clean lubricating oil.
5. Refer to Disassembly and Assembly, "Engine Oil Cooler - Install" for installation of the engine oil cooler.
6. Ensure that the lubrication and the cooling system of the engine is filled to the correct level. Operate the engine.

Note: Refer to Operation And Maintenance Manual, "Refill Capacities" for additional information.

Check for oil or coolant leakage.

i02414647

Water Temperature Regulator - Test

SMCS Code: 1355-081; 1355-081-ON

WARNING

Personal injury can result from escaping fluid under pressure.

If a pressure indication is shown on the indicator, push the release valve in order to relieve pressure before removing any hose from the radiator.

1. Remove the water temperature regulator from the engine. Refer to Disassembly and Assembly Manual, "Water Temperature Regulator - Remove and Install".
2. Heat water in a pan until the temperature of the water is equal to the fully open temperature of the water temperature regulator. Refer to Specifications, "Water Temperature Regulator" for the fully open temperature of the water temperature regulator. Stir the water in the pan. This will distribute the temperature throughout the pan.
3. Hang the water temperature regulator in the pan of water. The water temperature regulator must be below the surface of the water. The water temperature regulator must be away from the sides and the bottom of the pan.
4. Keep the water at the correct temperature for ten minutes.
5. After ten minutes, remove the water temperature regulator. Immediately measure the opening of the water temperature regulator. Refer to Specifications, "Water Temperature Regulator" for the minimum opening distance of the water temperature regulator at the fully open temperature.

If the distance is less than the amount listed in the manual, replace the water temperature regulator.

i04175229

Water Pump - Inspect

SMCS Code: 1361-040

1. Inspect the water pump for leaks at vent hole. The water pump seal is lubricated by coolant in the cooling system. A normal condition is for a small amount of leakage to occur as the engine cools down and the parts contract.
2. Refer to Disassembly and Assembly, "Water Pump - Remove" and Disassembly and Assembly, "Water Pump - Install" for the correct procedures to remove and install the water pump.
3. Inspect the water pump shaft for unusual noise, excessive looseness and/or vibration of the bearings.

Basic Engine

i04135750

Position the Valve Mechanism Before Maintenance Procedures

SMCS Code: 1102; 1121; 1123; 1209

NOTICE

Ensure that this procedure is carried out before the rocker shaft is removed.

Table 9

Required Tools			
Tool	Part Number	Part Description	Qty
A ⁽¹⁾	9U-6198	Crankshaft Turning Tool	1
A ⁽²⁾	5P-7306	Housing	1
	5P-7305	Engine Turning Tool	1

(1) The Crankshaft Turning Tool is used on the front pulley.

(2) This Tool is used in the aperture for the electric starting motor.

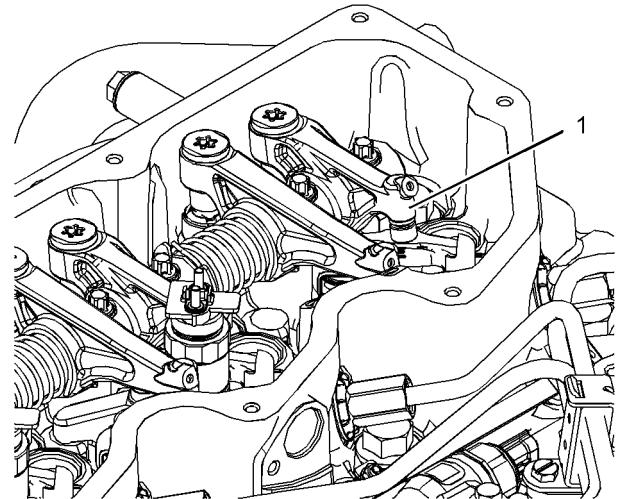

Illustration 86

g02333215

Typical example

One electronic unit injector is not shown for clarity.

2. Select an exhaust rocker arm (1). The exhaust rocker arm (1) can be on any cylinder.
3. Use Tooling (A) to rotate the crankshaft in the normal direction of rotation until the hydraulic lifter starts to open the exhaust valve. Continue to rotate the crankshaft until the valve has opened to the maximum extent. This is the safe position.

Note: Make temporary marks on the front pulley and the front housing once the engine is in the safe position.

NOTICE

Ensure that the crankshaft is located in the safe position before the rocker shaft assembly is installed.

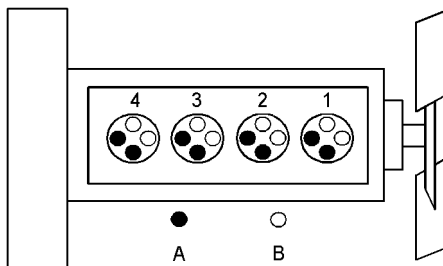

Illustration 85

g01335181

Cylinder and valve location

(A) Exhaust valve

(B) Inlet valve

1. Remove the valve mechanism cover. Refer to Disassembly and Assembly, "Valve Mechanism Cover - Remove and Install" for the correct procedure.

Piston Ring Groove - Inspect

SMCS Code: 1214-040

Table 10

Required Tools			
Tool	Part Number	Part Description	Qty
A	8H-8581	Feeler Gauge	1

Inspect the Piston and the Piston Rings

1. Check the piston for wear and other damage.

i03633934

2. Check that the piston rings are free to move in the grooves and that the rings are not broken.

Inspect the Clearance of the Piston Ring

1. Remove the piston rings (2). Refer to Disassembly and Assembly, "Pistons and Connecting Rods - Disassemble" for the correct procedure. Clean the grooves (1) and the piston rings (2).

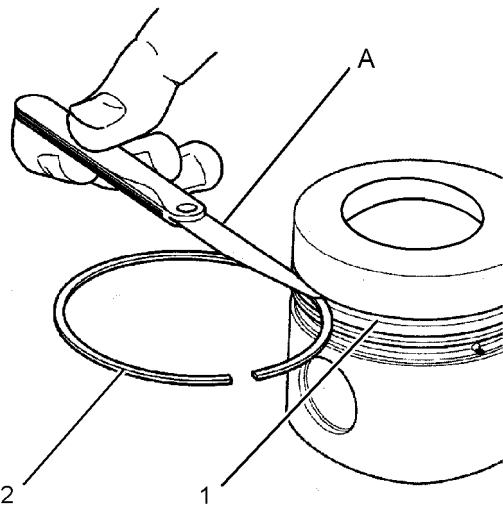

Illustration 87 g01200845

Typical example

- (A) Feeler gauge
(1) Piston grooves
(2) Piston ring

2. Install new piston rings (2) in the piston grooves (1). Refer to Disassembly and Assembly Manual, "Pistons and Connecting Rods - Assemble" for the correct procedure.
3. Check the clearance for the piston ring by placing Tooling (A) between piston groove (1) and the top of piston ring (2) for the intermediate ring and the oil control ring. Refer to Specifications, "Piston and Rings" for the dimensions.

Inspect the Piston Ring End Gap

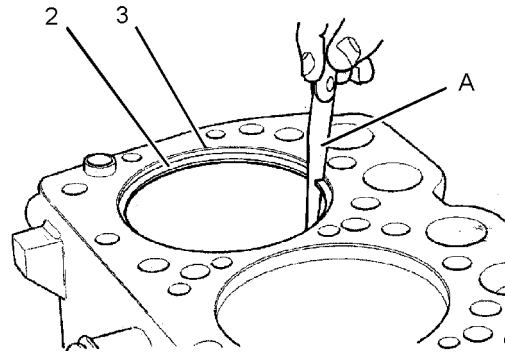

Illustration 88

g01344283

- (A) Feeler Gauge
(2) Piston ring
(3) Cylinder ring ridge

1. Clean all carbon from the top of the cylinder bores.
2. Place each piston ring (2) in the cylinder bore just below the cylinder ring ridge (3).
3. Use Tooling (A) to measure piston ring end gap. Refer to Specifications, "Piston and Rings" for the dimensions.

Note: The coil spring must be removed from the oil control ring before the gap of the oil control ring is measured.

i03996340

Connecting Rod - Inspect

SMCS Code: 1218-040

Note: If the crankshaft or the cylinder block are replaced, the piston height for all cylinders must be measured.

- New piston pin bearings must be bored after installation in the original connecting rods. Refer to "Piston Pin Bearings".

Note: When the piston pin is installed, always install new retaining rings on each end of the piston pin. If the piston pin cannot be removed by hand, heat the piston to a temperature of $45^{\circ} \pm 5^{\circ} \text{C}$ ($113^{\circ} \pm 9^{\circ} \text{F}$) in order to aid the removal of the piston pin. Heating the piston to this temperature may also aid the installation of the piston pin.

Piston Pin Bearings

Note: This procedure requires personnel with the correct training and the use of specialized equipment for machining.

If the piston pin bearing requires replacement but the original connecting rod is not replaced, the following procedures must be performed:

1. Determine the grade of length of the connecting rod. Use one of the following characteristics:
 - The mark
 - The color
 - Measuring the length
2. Remove the piston pin bearing from the connecting rod. Install a new bearing in the connecting rod. The new bearing is partially finished. The new bearing must be bored off-center to the correct diameter. This off-center position is determined by the grade of length of the connecting rod. Refer to table 11. The correct diameter of the bore in the piston pin bearing is given in Specifications, "Connecting Rod".

Surface finish of the bored hole in the piston pin bearing Ra 0.8 micrometers

3. Machine the ends of the piston pin bearing to the correct length. Remove any sharp edges. Refer to Specifications, "Connecting Rod".

Table 11 references the following information: Grade of letter of the connecting rod, the color code of the connecting rod, and the length of the connecting rod.

Table 11

Length Grades for Connecting Rods		
Grade Letter	Color Code	Length Of The Connecting Rod (CRL)
L	Blue	163.081 to 163.114 mm (6.42050 to 6.42180 inch)

i03191701

Cylinder Block - Inspect

SMCS Code: 1201-040

1. Clean all of the coolant passages and the oil passages.
2. Check the cylinder block for cracks and damage.
3. The top deck of the cylinder block must not be machined.

4. Check the front camshaft bearing for wear. Refer to Specifications, "Camshaft Bearings" for the correct specification of the camshaft bearing. If a new bearing is needed, use a suitable adapter to press the bearing out of the bore. Ensure that the oil hole in the new bearing faces the front of the block. The oil hole in the bearing must be aligned with the oil hole in the cylinder block. The bearing must be aligned with the face of the recess.

i03907820

Cylinder Head - Inspect

SMCS Code: 1100-040

1. Remove the cylinder head from the engine.
2. Remove the water temperature regulator housing.
3. Inspect the cylinder head for signs of gas or coolant leakage.
4. Remove the valve springs and valves.
5. Clean the bottom face of the cylinder head thoroughly. Clean the coolant passages and the lubricating oil passages. Make sure that the contact surfaces of the cylinder head and the cylinder block are clean, smooth, and flat.
6. Inspect the bottom face of the cylinder head for pitting, corrosion, and cracks. Inspect the area around the valve seat inserts and the holes for the fuel injection nozzles carefully.
7. Test the cylinder head for leaks at a pressure of 200 kPa (29 psi).

i04156268

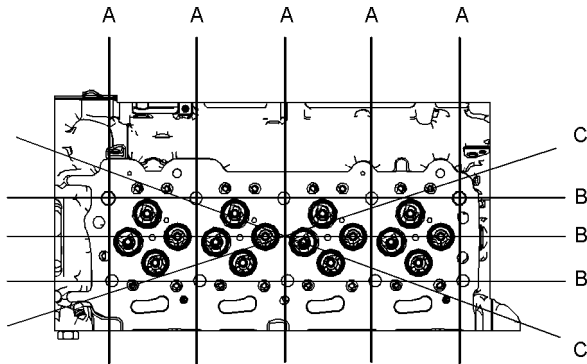

Illustration 89

g02148937

Flatness of the cylinder head (typical example)

- (A) Side to side
(B) End to end
(C) Diagonal

8. Measure the cylinder head for flatness. Use a straight edge and a feeler gauge to check the cylinder head for flatness.

- Measure the cylinder head from one side to the opposite side (A).
- Measure the cylinder head from one end to the opposite end (B).
- Measure the cylinder head from one corner to the opposite corner (C).

Refer to Specifications, "Cylinder Head" for the requirements of flatness.

Resurfacing the Cylinder Head

The bottom face of cylinder head can be resurfaced if any of the following conditions exist:

- The bottom face of the cylinder head is not flat within the specifications.
- The bottom face of the cylinder head is damaged by pitting, corrosion, or wear.

Note: The thickness of the cylinder head must not be less than 150.8 mm (5.93700 inch) after the cylinder head has been machined.

Note: The dimension of the valve seats to the flame face must be corrected after resurfacing the cylinder head. Refer to Specifications, "Cylinder Head" for the correct dimensions for the valve seats.

Piston Height - Inspect

SMCS Code: 1214-040

Table 12

Required Tools			
Tool	Part Number	Part Description	Qty
A	1P - 2403	Dial Indicator	1
B	1P - 2402	Gauge Body	1

If the height of the piston above the cylinder block is not within the tolerance that is given in Specifications, "Piston and Rings", the bearing for the piston pin must be checked. Refer to Systems Operation, Testing and Adjusting, "Connecting Rod - Inspect". If any of the following components are replaced or remachined, the piston height above the cylinder block must be measured:

- Crankshaft
- Cylinder head
- Connecting rod
- Bearing for the piston pin

The correct piston height must be maintained in order to ensure that the engine conforms to the standards for emissions.

Note: The top of the piston should not be machined. If the original piston is installed, be sure that the original piston is assembled to the correct connecting rod and installed in the original cylinder.

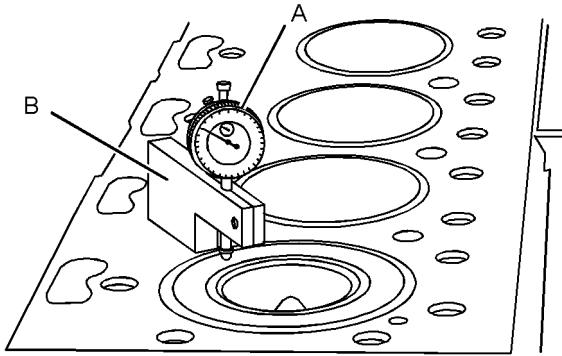

Illustration 90
Typical example
g01334423

3. Position Tooling (B) and Tooling (A) in order to measure the piston height above the cylinder block. The piston height should be measured at positions (X) or (Y). Slowly rotate the crankshaft in order to determine when the piston is at the highest position. Record this dimension. Compare this dimension with the dimensions that are given in Specifications, "Piston and Rings".

i03577920

Flywheel - Inspect

SMCS Code: 1156-040

Table 13

Required Tools			
Tool	Part Number	Part Description	Qty
A	8T - 5096	Dial Indicator Group	1

Alignment of the Flywheel Face

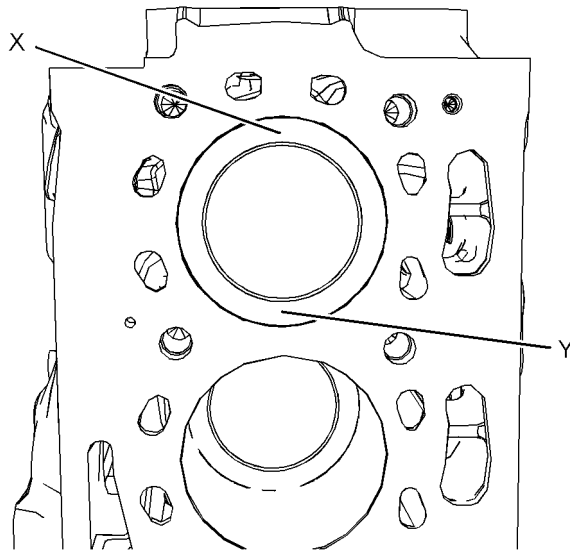

Illustration 91
Typical example
g02351060

1. Use Tooling (A) and Tooling (B) in order to measure the piston height above the cylinder block. Use the cylinder block face to zero Tooling (A).
2. Rotate the crankshaft until the piston is at the approximate top center.

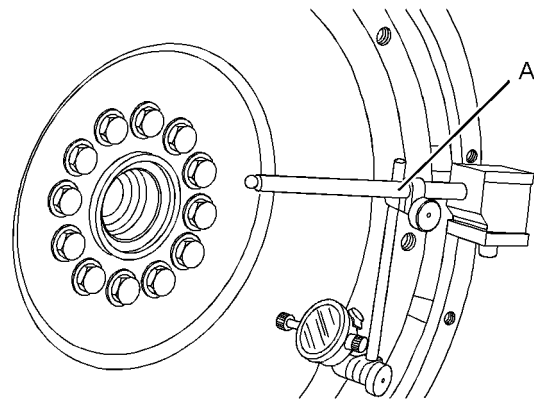

Illustration 92
Typical example
g01334421

1. Install Tooling (A) in illustration 92, as shown.
2. Set the pointer of the dial indicator to 0 mm (0 inch).
3. Turn the flywheel. Read the dial indicator for every 45 degrees.

Note: During the check, keep the crankshaft pressed toward the front of the engine in order to remove any end play.

- Calculate the difference between the lowest measurement and the highest measurement of the four locations. This difference must not be greater than 0.03 mm (0.001 inch) for every 25 mm (1.0 inch) of the radius of the flywheel. The radius of the flywheel is measured from the axis of the crankshaft to the contact point of the dial indicator.

Flywheel Runout

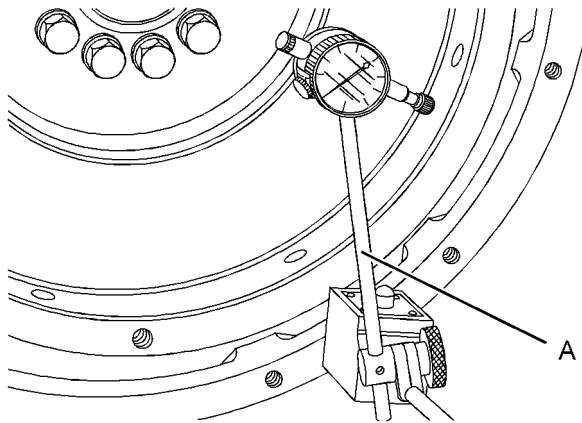

Illustration 93 g01334422
Typical example

- Install Tooling (A) in illustration 93, as shown.
- Set the pointer of the dial indicator to 0 mm (0 inch).
- Turn the flywheel. Read the dial indicator for every 45 degrees.
- Calculate the difference between the lowest measurement and the highest measurement of the four locations. This difference must not be greater than 0.30 mm (0.012 inch).

i02675737

Flywheel Housing - Inspect

SMCS Code: 1157-040

Table 14

Required Tools			
Tool	Part Number	Part Description	Qty
A	8T-5096	Dial Indicator Group	1

Concentricity of the Flywheel Housing

Note: This check must be made with the flywheel and the starter removed and the bolts for the flywheel housing tightened lightly.

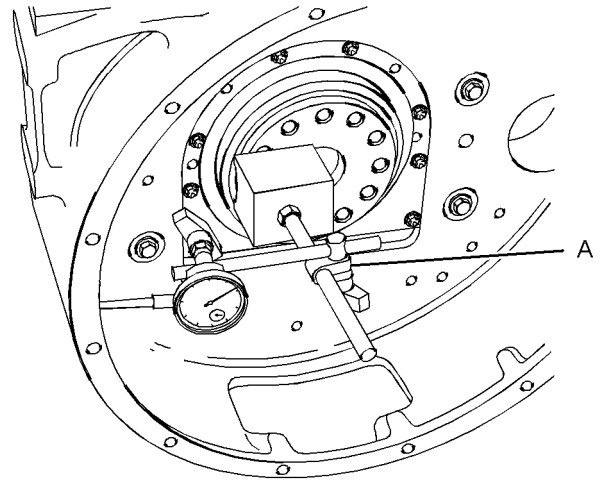

Illustration 94 g01344313
Typical example

- Install Tooling (A). See Illustration 94.
- Set the pointer of the dial indicator to 0 mm (0 inch).
- Check the concentricity at intervals of 45 degrees around the flywheel housing.
- Calculate the difference between the lowest measurement and the highest measurement. This difference must not be greater than the limit that is given in Table 15.

Note: Any necessary adjustment must be made on the flywheel housing. Then, recheck the concentricity.

Alignment of the Flywheel Housing

Note: This check must be made with the flywheel and the starter removed and the bolts for the flywheel housing tightened to the correct torque.

i03578981

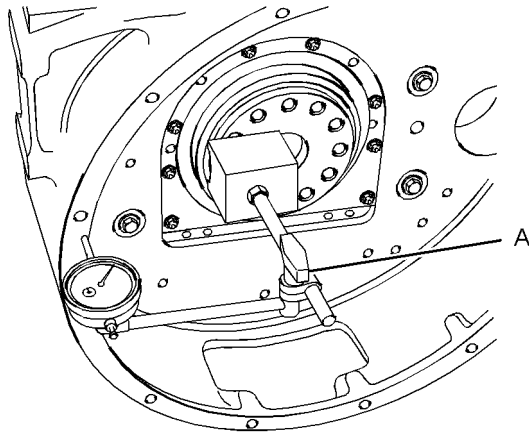

Illustration 95
Typical example

g01344315

1. Install Tooling (A). See Illustration 95.
2. Set the pointer of the dial indicator to 0 mm (0 inch).
3. Check the alignment at intervals of 45 degrees around the flywheel housing.
4. Calculate the difference between the lowest measurement and the highest measurement. This difference must not be greater than the limit that is given in Table 15.

Note: Any necessary adjustment must be made on the flywheel housing.

Table 15

Limits for Flywheel Housing Runout and Alignment (Total Indicator Reading)	
Bore of the Housing Flange	Maximum Limit (Total Indicator Reading)
410 mm (16.14 inch)	0.25 mm (0.010 inch)
448 mm (17.63 inch)	0.28 mm (0.011 inch)

Gear Group - Inspect

SMCS Code: 1206-040

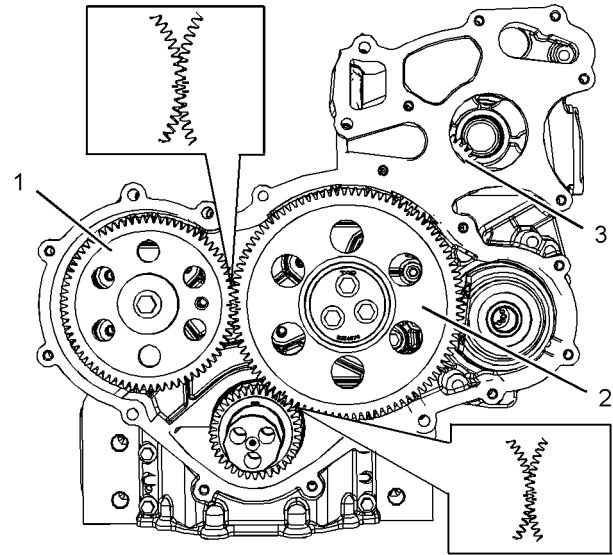

Illustration 96

g01907773

- (1) Camshaft gear
- (2) Idler gear
- (3) Fuel injection pump gear

Note: If one or more of the gears need to be removed for repair, refer to Disassembly and Assembly, "Gear Group (Front) - Remove" in order to properly remove the gears. Refer to the Disassembly and Assembly, "Gear Group (Front) - Install" in order to properly install the gears.

1. Inspect the gears for wear or for damage. If the gears are worn or damaged, use new parts for replacement.
2. Measure the backlash between the camshaft gear (1) and the idler gear (2). Refer to Specifications, "Gear Group (Front)" for the backlash measurement.
3. Measure the backlash between the idler gear (2) and the crankshaft gear (4). Refer to Specifications, "Gear Group (Front)" for the backlash measurement.
4. Measure the backlash between the fuel injection pump gear (3) and the idler gear (2). Refer to Specifications, "Gear Group (Front)" for the backlash measurement.
5. Measure the end play on idler gear (2). Refer to Disassembly and Assembly, "Idler Gear - Install" for the correct procedure. Refer to Specifications, "Gear Group (Front)" for the end play measurement.

i03910449

Crankshaft Pulley - Check

SMCS Code: 1205-535

The crankshaft pulley is installed on the front of the crankshaft.

Replace the crankshaft pulley if any of the following conditions exist:

- There is movement of the crankshaft pulley.
- There is a large amount of gear train wear that is not caused by lack of oil.
- Analysis of the engine oil has revealed that the front main bearing is badly worn.
- The engine has had a failure because of a broken crankshaft.

Check the areas around the holes for the bolts in the crankshaft pulley for cracks or for wear and for damage.

Use the following steps in order to check the alignment and the runout of the crankshaft pulley:

1. Remove any debris from the front face of the crankshaft pulley. Remove any debris from the circumference of the crankshaft pulley.
2. Mount the dial indicator on the front cover. Use the dial indicator to measure the outer face of the crankshaft pulley. Set the dial indicator to read 0.00 mm (0.00 inch).
3. Rotate the crankshaft at intervals of 45 degrees and read the dial indicator.
4. The difference between the lower measurements and the higher measurements that are read on the dial indicator at all four points must not be more than 0.18 mm (0.007 inch).

If the reading on the dial indicator is more than 0.18 mm (0.007 inch), inspect the pulley for damage. If the pulley is damaged, use new parts for replacement.

5. Move the dial indicator so that the dial indicator will measure the circumference of the crankshaft pulley. Set the dial indicator to read 0.00 mm (0.00 inch).
6. Slowly rotate the crankshaft in order to measure the runout of the circumference of the crankshaft pulley. Use the highest reading and the lowest reading on the dial indicator. The maximum and the minimum readings on the dial indicator should not vary more than 0.12 mm (0.005 inch).

If the reading on the dial indicator is more than 0.12 mm (0.005 inch), inspect the pulley for damage. If the pulley is damaged, use new parts for replacement.

Electrical System

i03578982

Alternator - Test

SMCS Code: 1405-081

1. Put the positive lead "+" of a suitable multimeter on the "B+" terminal of the alternator. Put the negative "-" lead on the ground terminal or on the frame of the alternator. Put a suitable ammeter around the positive output wire of the alternator.
2. Turn off all electrical accessories. Turn off the fuel to the engine. Crank the engine for 30 seconds. Wait for two minutes in order to cool the starting motor. If the electrical system appears to operate correctly, crank the engine again for 30 seconds.

Note: Cranking the engine for 30 seconds partially discharges the batteries in order to do a charging test. If the battery has a low charge, do not perform this step. Jump start the engine or charge the battery before the engine is started. For the correct procedure to jump start the engine, refer to Operation and Maintenance Manual, "Starting with Jump Start Cables".

3. Start the engine and run the engine at full throttle.
4. Check the output current of the alternator. The initial charging current should be equal to the minimum full load current or greater than the minimum full load current. The electrical load from the accessories may need to be added. Refer to Specifications, "Alternator" for the correct minimum full load current.

Table 16

Fault Conditions And Possible Causes			
Current At Start-up	The Voltage Is Below Specifications After 10 Minutes.	The Voltage Is Within Specifications After 10 Minutes.	The Voltage Is Above Specifications After 10 Minutes.
Less than the specifications	Replace the alternator. Check the circuit of the ignition switch.	Turn on all accessories. If the voltage decreases below the specifications, replace the alternator. Ensure that combined current of the accessories does not exceed the maximum output of the alternator.	-
Decreases after matching specifications	Replace the alternator.	The alternator and the battery match the specifications. Turn on all accessories in order to verify that the voltage stays within specifications. Ensure that combined current of the accessories does not exceed the maximum output of the alternator.	Replace the alternator.
The voltage consistently exceeds specifications.	-	The alternator operates within the specifications. Test the battery.	Replace the alternator. Inspect the battery for damage.

5. After approximately ten minutes of operating the engine at full throttle, the output voltage of the alternator should be 14.0 ± 0.5 volts for a 12 volt system and 28.0 ± 1 volts for a 24 volt system. Refer to the Fault Conditions And Possible Causes in table 16. Refer to Special Instruction, REHS0354, "Charging System Troubleshooting" for more information.
6. After ten minutes of engine operation, the charging current should decrease to approximately 10 amperes. The actual length of time for the decrease to 10 amperes depends on the following conditions:
 - The battery charge
 - The ambient temperature
 - The speed of the engine

Refer to the Fault Conditions And Possible Causes in table 16. Refer to Special Instruction, REHS0354, "Charging System Troubleshooting" for more information.

i01126605

Battery - Test

SMCS Code: 1401-081

Most of the tests of the electrical system can be done on the engine. The wiring insulation must be in good condition. The wire and cable connections must be clean, and both components must be tight.



Never disconnect any charging unit circuit or battery circuit cable from the battery when the charging unit is operated. A spark can cause an explosion from the flammable vapor mixture of hydrogen and oxygen that is released from the electrolyte through the battery outlets. Injury to personnel can be the result.

The battery circuit is an electrical load on the charging unit. The load is variable because of the condition of the charge in the battery.

NOTICE

The charging unit will be damaged if the connections between the battery and the charging unit are broken while the battery is being charged. Damage occurs because the load from the battery is lost and because there is an increase in charging voltage. High voltage will damage the charging unit, the regulator, and other electrical components.

See Special Instruction, SEHS7633, "Battery Test Procedure" for the correct procedures to use to test the battery. This publication also contains the specifications to use when you test the battery.

i03578983

Charging System - Test

SMCS Code: 1406-081

The condition of charge in the battery at each regular inspection will show if the charging system is operating correctly. An adjustment is necessary when the battery is constantly in a low condition of charge or a large amount of water is needed. A large amount of water would be more than 30 mL (1 oz) per cell per week or per every 100 service hours. There are no adjustments on maintenance free batteries.

When it is possible, make a test of the charging unit and voltage regulator on the engine, and use wiring and components that are a permanent part of the system. Off-engine testing or bench testing will give a test of the charging unit and voltage regulator operation. This testing will give an indication of needed repair. After repairs are made, perform a test in order to prove that the units have been repaired to the original condition of operation.

Alternator Regulator

The charging rate of the alternator should be checked when an alternator is charging the battery too much or not charging the battery enough.

Alternator output should be 28 ± 1 volt on a 24 volt system and 14 ± 0.5 volt on a 12 volt system. No adjustment can be made in order to change the rate of charge on the alternator regulators. If the rate of charge is not correct, a replacement of the regulator is necessary. For individual alternator output, refer to Specification, "Alternator and Regulator".

See Special Instruction, REHS0354, "Charging System Troubleshooting" for the correct procedures to use to test the charging system. This publication also contains the specifications to use when you test the charging system.

i03918602

V-Belt - Test

SMCS Code: 1357-081

The engine is equipped with an automatic belt tensioner. Manual adjustment of the belt is not required.

Poly V-Belt

NOTICE

Ensure that the engine is stopped before any servicing or repair is performed.

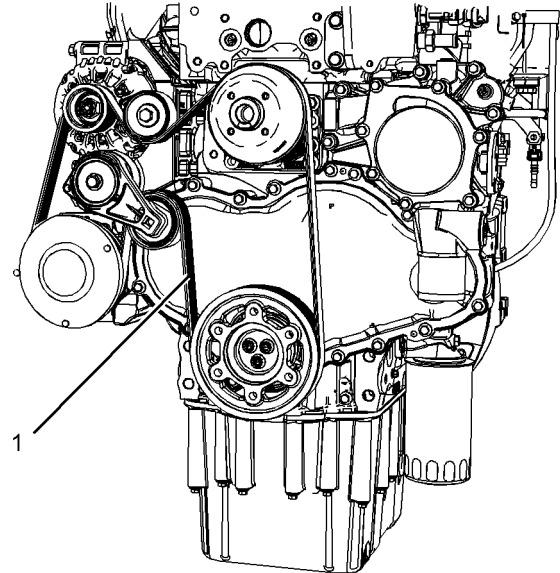

Illustration 97

g02151161

Typical example

To maximize the engine performance, inspect the poly v-belt (1) for wear and for cracking. Replace the poly v-belt if the belt is worn or damaged.

- Check the poly v-belt (1) for cracks, splits, glazing, grease, displacement of the cord and evidence of fluid contamination.

The poly v-belt must be replaced if the following conditions are present.

- The poly v-belt (1) has a crack in more than one rib.
- More than one section of the poly v-belt is displaced in one rib of a maximum length of 50.8 mm (2 inch).

To replace the poly v-belt, refer to Disassembly and Assembly, "Alternator Belt - Remove and Install". If necessary, replace the belt tensioner. Refer to Disassembly and Assembly, "Alternator Belt - Remove and Install" for the correct procedure.

i03578986

Electric Starting System - Test

SMCS Code: 1450-081

General Information

All electrical starting systems have four elements:

- Keyswitch
- Start relay
- Starting motor solenoid
- Starting motor

The starting motor solenoid is a switch with a capacity of about 1000 amperes. The starting motor solenoid supplies power to the starter drive. The starting motor solenoid also engages the pinion to the flywheel.

The starting motor solenoid has two coils. The pull-in coil draws about 40 amperes. The hold-in coil requires about 5 amperes.

When the magnetic force increases in both coils, the pinion gear moves toward the ring gear of the flywheel. Then, the solenoid contacts close in order to provide power to the starting motor. When the solenoid contacts close, the ground is temporarily removed from the pull-in coil. Battery voltage is supplied on both ends of the pull-in coil while the starting motor cranks. During this period, the pull-in coil is out of the circuit.

Cranking of the engine continues until current to the solenoid is stopped by releasing the keyswitch.

Power which is available during cranking varies according to the temperature and condition of the batteries. Table 17 shows the voltages which are expected from a battery at the various temperature ranges.

Table 17

Typical Voltage Of Electrical System During Cranking At Various Ambient Temperatures		
Temperature	12 Volt System	24 Volt System
-23 to -7°C (-10 to 20°F)	6 to 8 volts	12 to 16 volts
-7 to 10°C (20 to 50°F)	7 to 9 volts	14 to 18 volts
10 to 27°C (50 to 80°F)	8 to 10 volts	16 to 24 volts

Table 18 shows the maximum acceptable loss of voltage in the battery circuit. The battery circuit supplies high current to the starting motor. The values in the table are for engines which have service of 2000 hours or more.

Table 18

Maximum Acceptable Voltage Drop In The Starting Motor Circuit During Cranking		
Circuit	12 Volt System	24 Volt System
Battery post "-" to the starting motor terminal "-"	0.7 volts	1.4 volts
Drop across the disconnect switch	0.5 volts	1.0 volts
Battery post "+" to the terminal of the starting motor solenoid "+"	0.5 volts	1.0 volts
Solenoid terminal "Bat" to the solenoid terminal "Mtr"	0.4 volts	0.8 volts

Voltage drops that are greater than the amounts in table 18 are caused most often by the following conditions:

- Loose connections
- Corroded connections
- Faulty switch contacts

Diagnosis Procedure

The procedures for diagnosing the starting motor are intended to help the technician determine if a starting motor needs to be replaced or repaired. The procedures are not intended to cover all possible problems and conditions. The procedures serve only as a guide.

NOTICE

If equipped with electric start, do not crank the engine for more than 30 seconds. Allow the starter to cool for two minutes before cranking again.

Never turn the disconnect switch off while the engine is running. Serious damage to the electrical system can result.

If the starting motor does not crank or cranks slow, perform the following procedure:

1. Measure the voltage of the battery.

Measure the voltage across the battery posts with the multimeter when you are cranking the engine or attempting to crank the engine. Do not measure the voltage across the cable post clamps.

- a. If the voltage is equal to or greater than the voltage in table 17, then go to step 2.

- b. The battery voltage is less than the voltage in Table 17.

A low charge in a battery can be caused by several conditions.

- Deterioration of the battery
- A shorted starting motor
- A faulty alternator
- Loose drive belts
- Current leakage in another part of the electrical system

2. Measure the current that is sent to the starting motor solenoid from the positive post of the battery.

Note: If the following conditions exist, do not perform the test in step 2 because the starting motor has a problem.

- The voltage at the battery post is within 2 volts of the lowest value in the applicable temperature range of table 17.
- The large starting motor cables get hot.

Use a suitable ammeter in order to measure the current. Place the jaws of the ammeter around the cable that is connected to the “bat” terminal. Refer to Specifications, “Starter Motor” for the maximum current that is allowed for no load conditions.

The current and the voltages that are specified in Specifications are measured at a temperature of 27°C (80°F). When the temperature is below 27°C (80°F), the voltage will be lower through the starting motor. When the temperature is below 27°C (80°F), the current through the starting motor will be higher. If the current is too great, a problem exists in the starting motor. Repair the problem or replace the starting motor.

If the current is within the specification, proceed to step 3.

3. Measure the voltage of the starting motor.

- a. Use the multimeter in order to measure the voltage of the starting motor, when you are cranking or attempting to crank the engine.
- b. If the voltage is equal to or greater than the voltage that is given in table 17, then the battery and the starting motor cable that goes to the starting motor are within specifications. Go to step 5.

- c. The starting motor voltage is less than the voltage specified in table 17. The voltage drop between the battery and the starting motor is too great. Go to step 4.

4. Measure the voltage.

- a. Measure the voltage drops in the cranking circuits with the multimeter. Compare the results with the voltage drops which are allowed in table 18.
- b. Voltage drops are equal to the voltage drops that are given in table 18 or the voltage drops are less than the voltage drops that are given in Table 18. Go to step 5 in order to check the engine.

- c. The voltage drops are greater than the voltage drops that are given in table 18. The faulty component should be repaired or replaced.

5. Rotate the crankshaft by hand in order to ensure that the crankshaft is not stuck. Check the oil viscosity and any external loads that could affect the engine rotation.

- a. If the crankshaft is stuck or difficult to turn, repair the engine.

- b. If the engine is not difficult to turn, go to step 6.

6. Attempt to crank the starting motor.

- a. The starting motor cranks slowly.

Remove the starting motor for repair or replacement.

- b. The starting motor does not crank.

Check for the blocked engagement of the pinion gear and flywheel ring gear.

Note: Blocked engagement and open solenoid contacts will give the same electrical symptoms.

Index

A

Air in Fuel - Test.....	61
Air Inlet and Exhaust System	67
Air Inlet and Exhaust System - Inspect.....	67
Inspection of the Crankcase Breather.....	67
Air Inlet and Exhaust System (Series Turbochargers)	20
Crankcase Breather	24
Turbochargers.....	23
Valve System Components.....	25
Air Inlet and Exhaust System (Single Turbocharger)	14
Crankcase Breather	18
Turbocharger	17
Valve System Components.....	19
Alternator - Test	94

B

Basic Engine.....	10, 86
Camshaft.....	13
Crankshaft.....	12
Cylinder Block.....	11
Cylinder Head	11
Gears and Timing Gear Case	13
Introduction	10
Pistons, Rings, and Connecting rods.....	12
Battery - Test	95

C

Charging System - Test	96
Alternator Regulator.....	96
Clean Emissions Module	25
Cleanliness of Fuel System Components.....	31
Cleanliness of the Engine	31
Environment.....	31
New Components	31
Refueling.....	31
Compression - Test.....	75
Connecting Rod - Inspect.....	87
Piston Pin Bearings.....	88
Cooling System	27, 82
Coolant Flow	28
Introduction	27
Cooling System - Check.....	82
Engine And Cooling System Heat Problems	82
Cooling System - Inspect.....	82
Visual Inspection Of The Cooling System.....	82
Cooling System - Test.....	83
Checking the Filler Cap.....	83
Making the Correct Antifreeze Mixtures.....	83
Testing The Radiator And Cooling System For Leaks.....	84
Crankshaft Pulley - Check	93
Cylinder Block - Inspect.....	88

Cylinder Head - Inspect.....	88
Resurfacing the Cylinder Head	89

E

Electric Starting System - Test.....	96
Diagnosis Procedure.....	97
General Information	96
Electrical System.....	29, 94
Alternator	30
Starting Motor	29
Electronic Control System	39
Diagnostic Codes.....	48
ECM.....	47
Introduction	39
Passwords	48
Pressure Sensors	50
Sensor Locations for the Clean Emissions Module	46
Sensor Locations for the Engine.....	41
Sensors for the NOx Reduction System (NRS)..	52
Speed/Timing Sensors.....	49
Temperature Sensors.....	51
Engine Oil Cooler - Inspect.....	84
Engine Oil Pressure - Test.....	79
High Oil Pressure.....	79
Low Oil Pressure.....	79
Engine Oil Pump - Inspect.....	79
Engine Operation.....	10
Engine Valve Lash - Inspect	75
Valve Lash Check	76
Excessive Bearing Wear - Inspect.....	80
Excessive Engine Oil Consumption - Inspect.....	80
Engine Oil Leaks into the Combustion Area of the Cylinders	80
Engine Oil Leaks on the Outside of the Engine ..	80
Exhaust Cooler (NRS) - Test	74

F

Finding Top Center Position for No. 1 Piston.....	63
Flywheel - Inspect.....	90
Alignment of the Flywheel Face.....	90
Flywheel Runout	91
Flywheel Housing - Inspect	91
Alignment of the Flywheel Housing.....	91
Concentricity of the Flywheel Housing.....	91
Fuel Injection	31
Fuel Injectors	38
Fuel Manifold	39
Fuel Pump Assembly	35
Introduction	31
Primary Filter/Water Separator	35
Secondary Fuel Filter.....	35
Fuel Injection Timing - Check	64
Fuel Quality - Test.....	65
Fuel System.....	61
Fuel System - Inspect.....	61

Fuel System - Prime 65

G

Gear Group - Inspect..... 92
Gear Group (Front) - Time..... 66
General Information..... 4
Glossary of Electronic Control Terms 55

I

Important Safety Information 2
Increased Engine Oil Temperature - Inspect 81
Introduction..... 4
 C4.4 Engine with Series Turbochargers 5
 C4.4 Engine with Single Turbocharger 8

L

Lubrication System 29, 79

P

Piston Height - Inspect 89
Piston Ring Groove - Inspect..... 86
 Inspect the Clearance of the Piston Ring..... 87
 Inspect the Piston and the Piston Rings 86
 Inspect the Piston Ring End Gap..... 87
Position the Valve Mechanism Before Maintenance
 Procedures 86
Power Sources 52
 ECM Power Supply..... 53
 Introduction 52
 Power Supply for the Glow plugs..... 55
 Power Supply for the Pressure Sensors..... 54

S

Systems Operation Section 4

T

Table of Contents..... 3
Testing and Adjusting Section 61
Turbocharger - Inspect (Series Turbochargers) 68
 Inspection of the Compressor and the Compressor
 Housing 69
 Inspection of the Turbine Wheel and the Turbine
 Housing 69
 Inspection of the Wastegate 70

Turbocharger - Inspect (Single Turbocharger) 71
 Inspection of the Compressor and the Compressor
 Housing 71
 Inspection of the Turbine Wheel and the Turbine
 Housing 72
 Inspection of the Wastegate 72

V

V-Belt - Test 96
 Poly V-Belt 96
Valve Depth - Inspect 77
Valve Guide - Inspect 78

W

Water Pump - Inspect..... 85
Water Temperature Regulator - Test 85