



# Systems Operation Testing and Adjusting

---

## **3126B and 3126E Truck Engine**

---

BKD1-Up (Engine)  
G3E1-Up (Engine)  
DPF1-Up (Engine)  
1AJ1-Up (Engine)  
8YL1-Up (Engine)  
CKM1-Up (Engine)  
CRP1-Up (Engine)  
7AS1-Up (Engine)  
8SZ1-Up (Engine)  
9SZ1-Up (Engine)

## Important Safety Information

Most accidents that involve product operation, maintenance and repair are caused by failure to observe basic safety rules or precautions. An accident can often be avoided by recognizing potentially hazardous situations before an accident occurs. A person must be alert to potential hazards. This person should also have the necessary training, skills and tools to perform these functions properly.

**Improper operation, lubrication, maintenance or repair of this product can be dangerous and could result in injury or death.**

**Do not operate or perform any lubrication, maintenance or repair on this product, until you have read and understood the operation, lubrication, maintenance and repair information.**

Safety precautions and warnings are provided in this manual and on the product. If these hazard warnings are not heeded, bodily injury or death could occur to you or to other persons.

The hazards are identified by the "Safety Alert Symbol" and followed by a "Signal Word" such as "DANGER", "WARNING" or "CAUTION". The Safety Alert "WARNING" label is shown below.



The meaning of this safety alert symbol is as follows:

**Attention! Become Alert! Your Safety is Involved.**

The message that appears under the warning explains the hazard and can be either written or pictorially presented.

Operations that may cause product damage are identified by "NOTICE" labels on the product and in this publication.

**Caterpillar cannot anticipate every possible circumstance that might involve a potential hazard. The warnings in this publication and on the product are, therefore, not all inclusive. If a tool, procedure, work method or operating technique that is not specifically recommended by Caterpillar is used, you must satisfy yourself that it is safe for you and for others. You should also ensure that the product will not be damaged or be made unsafe by the operation, lubrication, maintenance or repair procedures that you choose.**

The information, specifications, and illustrations in this publication are on the basis of information that was available at the time that the publication was written. The specifications, torques, pressures, measurements, adjustments, illustrations, and other items can change at any time. These changes can affect the service that is given to the product. Obtain the complete and most current information before you start any job. Caterpillar dealers have the most current information available.



**When replacement parts are required for this product Caterpillar recommends using Caterpillar replacement parts or parts with equivalent specifications including, but not limited to, physical dimensions, type, strength and material.**

**Failure to heed this warning can lead to premature failures, product damage, personal injury or death.**

---

# Table of Contents

## Systems Operation Section

General Information .....	4
Fuel System .....	7
Air Inlet and Exhaust System .....	36
Lubrication System .....	40
Cooling System .....	42
Basic Engine .....	45
Electrical System .....	48

## Testing and Adjusting Section

### Fuel System

Fuel System - Inspect .....	52
Air in Fuel - Test .....	53
Engine Speed - Check .....	54
Finding Top Center Position for No. 1 Piston .....	55
Fuel Quality - Test .....	56
Fuel System - Prime .....	57
Fuel System Pressure - Test .....	58
Gear Group (Front) - Time .....	60
Unit Injector - Test .....	60

### Air Inlet and Exhaust System

Air Inlet and Exhaust System - Inspect .....	62
Turbocharger - Inspect .....	65
Inlet Manifold Pressure - Test .....	68
Exhaust Temperature - Test .....	69
Aftercooler - Test .....	69
Engine Crankcase Pressure (Blowby) - Test .....	72
Compression - Test .....	73
Engine Valve Lash - Inspect/Adjust .....	73

### Lubrication System

Engine Oil Pressure - Test .....	76
Engine Oil Pump - Inspect .....	79
Excessive Bearing Wear - Inspect .....	79
Excessive Engine Oil Consumption - Inspect .....	79
Increased Engine Oil Temperature - Inspect .....	80

### Cooling System

Cooling System - Check (Overheating) .....	81
Cooling System - Inspect .....	83
Cooling System - Test .....	84
Water Temperature Regulator - Test .....	88
Water Pump - Test .....	89

### Basic Engine

Piston Ring Groove - Inspect .....	90
Connecting Rod Bearings - Inspect .....	90
Main Bearings - Inspect .....	90
Cylinder Block - Inspect .....	90
Flywheel - Inspect .....	91
Flywheel Housing - Inspect .....	92
Vibration Damper - Check .....	94
Vibration Damper - Check .....	95

### Electrical System

Battery - Test .....	97
----------------------	----

Charging System - Test .....	98
Electric Starting System - Test .....	99
Engine Oil Pressure Sensor - Test .....	100
Exhaust Particulate Filter Diagnostic Module - Test .....	100
Pinion Clearance - Adjust .....	102
Pinion Clearance - Adjust .....	102

## Index Section

Index .....	104
-------------	-----

# Systems Operation Section

i02497376

## General Information

SMCS Code: 1000

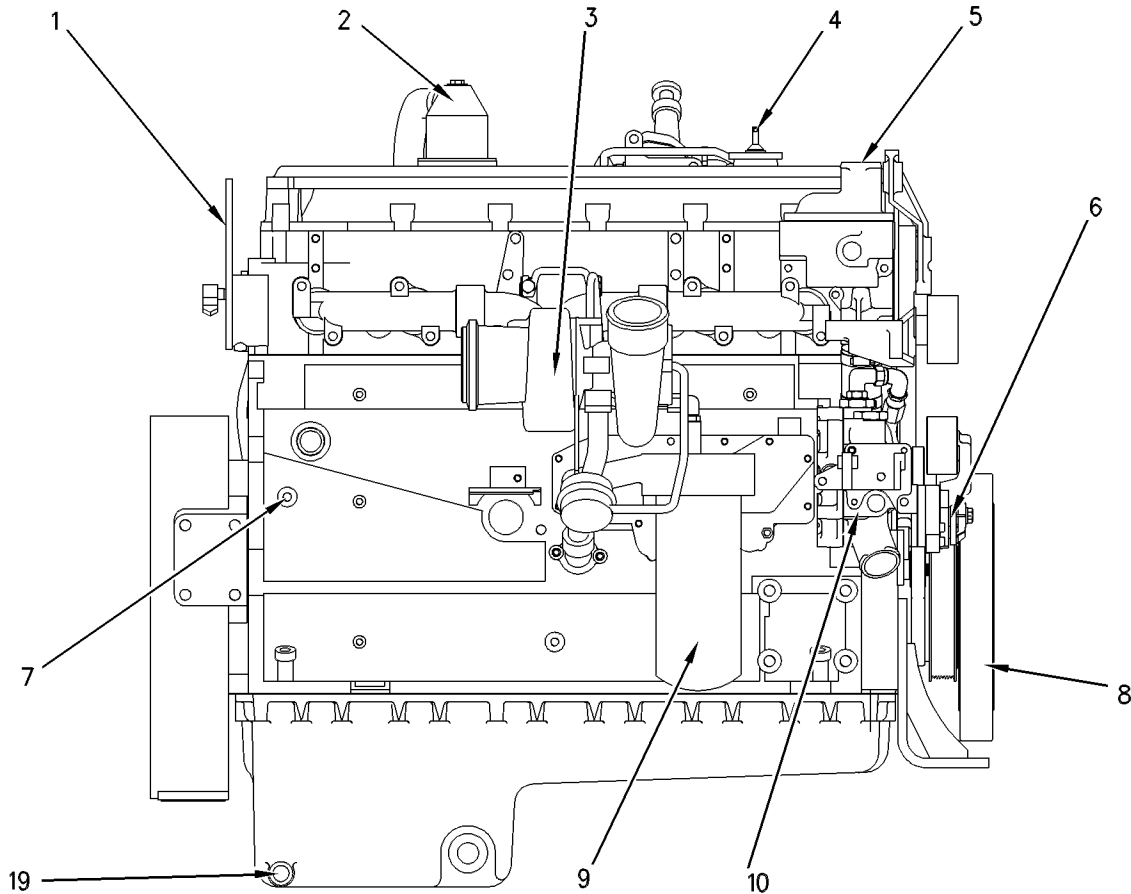

Illustration 1

g00608514

Right side view

- |   |                                 |
|---|---------------------------------|
| (1) Lifting eye                         | (6) Belt tensioner              |
| (2) Engine crankcase breather           | (7) Water drain plug            |
| (3) Turbocharger                        | (8) Crankshaft vibration damper |
| (4) Oil filler                          | (9) Oil filter                  |
| (5) Water temperature regulator housing | (10) Jacket water pump          |

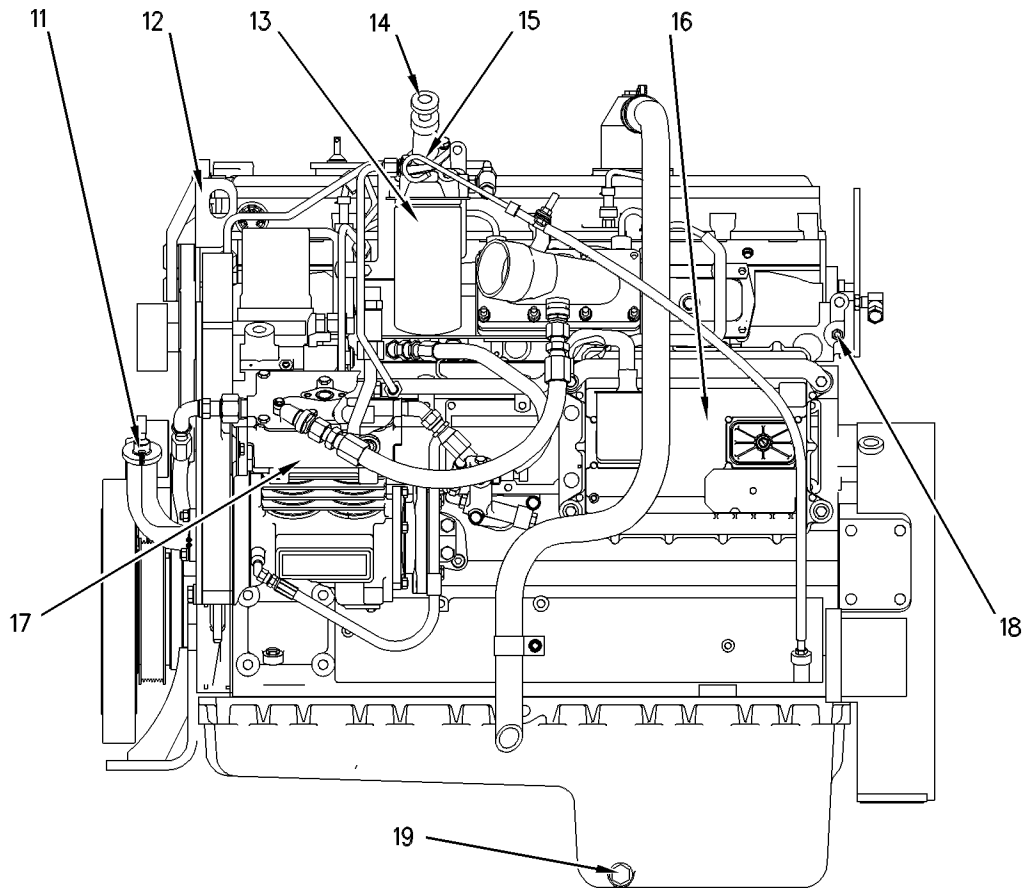

Illustration 2

g00608515

Left side view

- |                  |  |                                   |
|------------------|--|-----------------------------------|
| (11) Oil filler  | (14) Fuel priming pump (if equipped)   | (17) Air compressor               |
| (12) Lifting eye | (15) Oil level gauge (typical example) | (18) Cylinder head grounding stud |
| (13) Fuel filter | (16) Engine Control Module (ECM)       | (19) Oil drain plug               |

The 3126B and 3126E engines are in-line six cylinder arrangements. The firing order of the engine is 1-5-3-6-2-4. The engine's rotation is counterclockwise when the engine is viewed from the flywheel end of the engine. The engine utilizes a turbocharger and an air-to-air aftercooler. The engines have a bore of 110 mm (4.3 inch) and a stroke of 127 mm (5.0 inch). The displacement is 7.25 L (442 cu in).

The hydraulic electronic unit injector system (HEUI) eliminates many of the mechanical components that are used in a pump-and-line system. The HEUI also provides increased control of the timing and increased control of the fuel air mixture. The timing advance is achieved by precise control of the unit injector timing. Engine rpm is controlled by adjusting the injection duration. A special pulse wheel provides information to the Engine Control Module (ECM) for detection of cylinder position and engine rpm.

The engine has built-in diagnostics in order to ensure that all of the components are operating properly. In the event of a system component failure, the operator will be alerted to the condition via the check engine light that is located on the dashboard. An electronic service tool can be used to read the numerical code of the faulty component or condition. Also, the cruise control switches can be used to flash the code on the check engine light. Intermittent faults are logged and stored in memory.

## Starting The Engine

The engine's ECM will automatically provide the correct amount of fuel in order to start the engine. Do not hold the throttle down while the engine is cranking. If the engine fails to start in twenty seconds, release the starting switch. Allow the starting motor to cool for two minutes before the starting motor is used again.

---

**NOTICE**

Excessive ether (starting fluid) can cause piston and ring damage. Use ether for cold weather starting purposes only.

---

## **Cold Mode Operation**

Starting the engine and operation in cold weather is dependent on the type of fuel that is used, the oil viscosity, and other optional starting aids. For more information, refer to the Operation and Maintenance Manual, "Cold Weather Operation" topic (Operation Section).

i01750138

## **Fuel System**

**SMCS Code:** 1250

# Introduction

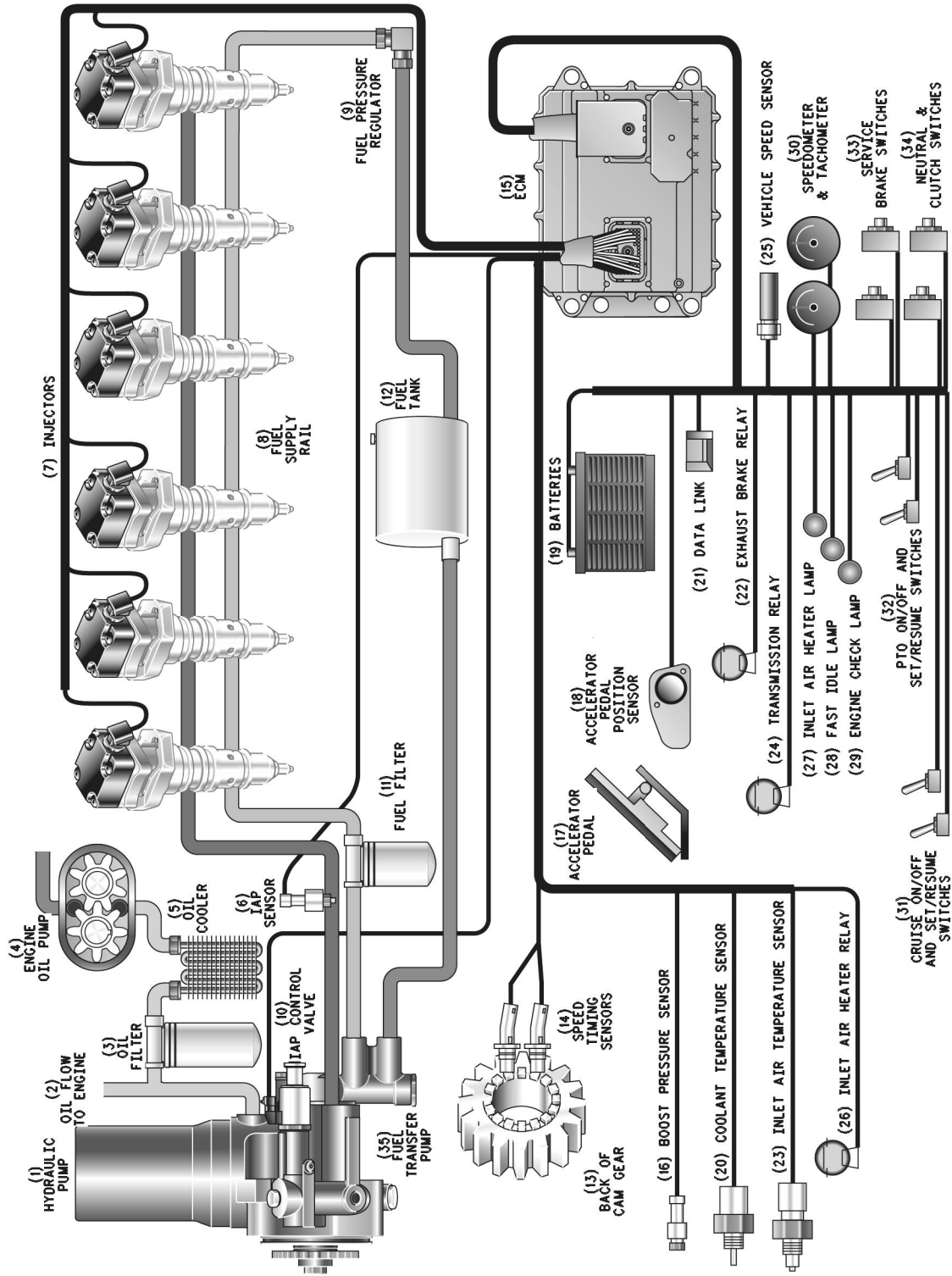

Illustration 3  
Diagram of components for the HEUI fuel system

- |                                  |  |  |
|----------------------------------|--|--|
| (1) Unit injector hydraulic pump | (14) Speed/timing sensors              | (27) Inlet air heater lamp                             |
| (2) Oil flow to engine           | (15) ECM                               | (28) Fast idle lamp                                    |
| (3) Oil filter                   | (16) Boost pressure sensor             | (29) Check engine lamp                                 |
| (4) Engine oil pump              | (17) Accelerator pedal                 | (30) Speedometer and tachometer                        |
| (5) Oil cooler                   | (18) Accelerator pedal position sensor | (31) Cruise ON/OFF switch and Cruise SET/RESUME switch |
| (6) IAP sensor                   | (19) Batteries                         | (32) PTO ON/OFF switch and SET/RESUME switch           |
| (7) Injectors                    | (20) Coolant temperature sensor        | (33) Service brake switches                            |
| (8) Fuel supply rail             | (21) Data link                         | (34) Neutral and clutch switches                       |
| (9) Fuel pressure regulator      | (22) Exhaust brake relay               | (35) Fuel transfer pump                                |
| (10) IAP control valve           | (23) Inlet air temperature sensor      |  |
| (11) Fuel filter                 | (24) Transmission relay                |  |
| (12) Fuel tank                   | (25) Vehicle speed sensor              |  |
| (13) Back of cam gear            | (26) Inlet air heater relay            |  |

The operation of the Hydraulic Electronic Unit Injector (HEUI) fuel system is completely different from any other type of fuel system that is actuated mechanically. The HEUI fuel system is completely free of adjustment. Adjustments to the components that are mechanical can not be made. Changes in performance are made by installing different software in Engine Control Module (ECM) (15).

This fuel system consists of six basic components:

- Hydraulic Electronic Unit Injector (HEUI) (7)
- Engine Control Module (ECM) (15)
- Unit injector hydraulic pump (1)
- Injection Actuation Pressure Control Valve (10)
- Fuel Transfer Pump (35)
- Injection Actuation Pressure Sensor (6)

**Note:** The components of the HEUI fuel system are not serviceable. These fuel system components must not be disassembled. Disassembly will damage the components. If the components have been disassembled, Caterpillar may not allow a warranty claim or Caterpillar may reduce the warranty claim.

## Component Description

### Hydraulic Electronic Unit Injector

The HEUI fuel system utilizes a hydraulically actuated electronically controlled unit injector (7).

All fuel systems for diesel engines use a plunger and barrel in order to pump fuel under high pressure into the combustion chamber. This fuel is pumped into the combustion chamber in precise amounts in order to control engine performance. The HEUI uses engine oil under high pressure in order to power the plunger. All other fuel systems use a fuel injection pump camshaft lobe in order to power the plunger. Because the HEUI is much different, a technician must use different troubleshooting methods.

The HEUI uses engine lubrication oil that is pressurized from 6 MPa (870 psi) to 27.5 MPa (4000 psi) in order to pump fuel from the injector. The HEUI operates in the same way as a hydraulic cylinder in order to multiply the force of the high pressure oil. By multiplying the force of the high pressure oil, the HEUI can produce injection pressures that are very high. This multiplication of pressure is achieved by applying the force of the high pressure oil to a piston. The piston is larger than the plunger by approximately six times. The piston that is powered by engine lubrication oil under high pressure pushes on the plunger. This engine lubrication oil under high pressure is called the actuation pressure of the oil. The actuation pressure of the oil generates the injection pressure that is delivered by the unit injector. Injection pressure is greater than actuation pressure of the oil by approximately six times.

Low actuation pressure of the oil results in low injection pressure of the fuel. During conditions of low speed such as idle and start, low injection pressure is utilized.

High actuation pressure of the oil results in high injection pressure of the fuel. During conditions of high speed such as high idle and acceleration, high injection pressure is utilized.

There are many other operating conditions when the injection pressure is between the minimum and the maximum. Regardless of the speed of the engine, the HEUI fuel system provides infinite control of injection pressure.

### Engine Control Module (ECM)

Engine Control Module (ECM) (15) is located on the left side of the engine. The ECM is a powerful computer that provides total electronic control of engine performance. The ECM uses data from engine performance that is gathered by several sensors. Then, the ECM uses this data in order to make adjustments to the fuel delivery, injection pressure and injection timing. The ECM contains programmed performance maps (software) in order to define horsepower, torque curves and rpm. This software is commonly called the personality module.



Some engines use Engine Control Modules (ECM) (15) with a replaceable computer chip. The software has already been installed in the replaceable computer chip. The 3126B and 3126E diesel truck engines do not have a replaceable personality module. The 3126B and 3126E diesel truck engine's personality module are a permanent part of the ECM. The 3126B and 3126E diesel truck engine's personality module can be reprogrammed. Reprogramming of the personality module requires the use of Caterpillar Electronic Technician (Cat ET). The flash function of Cat ET will be used during the reprogramming.

ECM (15) logs faults of engine performance. Also, the ECM is capable of running several diagnostic tests automatically when the ECM is used with an electronic service tool such as the Cat ET.

### **Unit injector hydraulic pump**

Unit injector hydraulic pump (1) (high pressure oil pump) is located at the left front corner of the engine. The unit injector hydraulic pump is a piston pump that has a fixed displacement. The unit injector hydraulic pump uses an axial piston. The unit injector hydraulic pump uses a portion of the engine lubrication oil. The unit injector hydraulic pump pressurizes the engine lubrication oil to the injection actuation pressure that is required in order to power the HEUI injectors.

### **Injection Actuation Pressure Control Valve (IAP Control Valve)**

Injection actuation pressure control valve (10) (IAP Control Valve) is located on the side of unit injector hydraulic pump (1). Under most conditions, the pump is producing excess oil flow. The IAP Control Valve discharges excess pump flow to the drain in order to control injection actuation pressure to the desired level. The IAP Control Valve is a valve of high precision that controls the actual actuation pressure. The performance maps of ECM (15) contain a desired actuation pressure for every engine operating condition. The ECM sends a control current to the IAP Control Valve. The control current should make the actual actuation pressure equal to the desired actuation pressure.

IAP Control Valve (10) is an actuator. The IAP Control Valve converts an electrical signal from ECM (15) to the mechanical control of a spool valve in order to control pump outlet pressure.

### **Fuel Transfer Pump**

Fuel transfer pump (35) is mounted on the back of unit injector hydraulic pump (1). The fuel transfer pump is used in order to draw fuel from fuel tank (12). Also, the fuel transfer pump is used in order to pressurize the fuel to 450 kPa (65 psi). The pressurized fuel is supplied to injectors (7).

Fuel transfer pump (35) is a single piston pump that is spring loaded. The shaft of the unit injector hydraulic pump provides power to the transfer pump through an off-center bearing. There are two check valves in the fuel transfer pump. The inlet check valve opens in order to allow fuel from the tank into the pump. The inlet check valve closes in order to prevent fuel leakage back to the fuel tank. The outlet check valve opens in order to supply fuel to the fuel supply passage. The fuel supply passage is located in the cylinder head. The fuel supply passage supplies fuel to injectors (7). The outlet check valve closes in order to prevent pressurized fuel leakage back through the pump.

### **Injection Actuation Pressure Sensor (IAP)**

IAP Sensor (6) is installed in the high pressure oil manifold. The high pressure oil manifold supplies actuation oil in order to power the unit injectors. The IAP Sensor monitors injection actuation pressure. The IAP Sensor sends a continuous voltage signal back to ECM (15). The ECM interprets the signal. The ECM is aware of the injection actuation pressure at all times.

# HEUI Fuel System Operation

## Low Pressure Fuel System

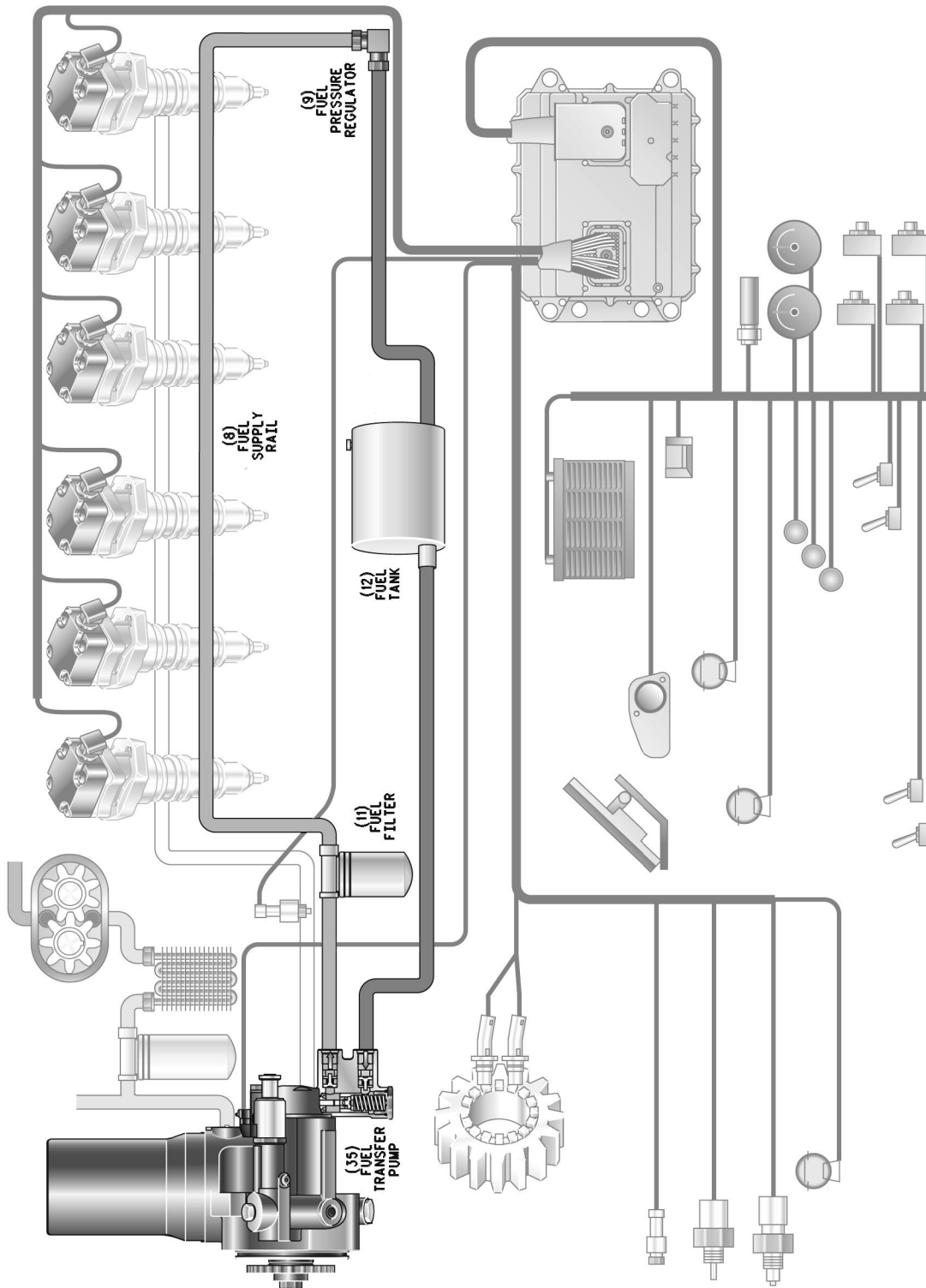

Illustration 4  
Low pressure fuel system

(8) Fuel supply line  
(9) Fuel pressure regulator

(11) Fuel filter  
(12) Fuel tank

(35) Fuel transfer pump

The low pressure fuel system serves three functions. The low pressure fuel system supplies fuel for combustion to injectors (7). Also, the low pressure fuel system supplies excess fuel flow in order to cool the unit injectors and the low pressure fuel system supplies excess fuel flow in order to remove air from the system.

The low pressure fuel system consists of four basic components:

- Fuel pressure regulator (9)
- Fuel filter (11)
- Fuel tank (12)
- Fuel transfer pump (35)

Fuel transfer pump (35) is mounted on the back of unit injector hydraulic pump (1). The fuel transfer pump pushes pressurized fuel out of the outlet port and the fuel transfer pump draws new fuel into the inlet port.

Fuel is drawn from fuel tank (12) and flows through two micron fuel filter (11).

Fuel flows from fuel filter (11) to the inlet side of fuel transfer pump (35). An inlet check valve in the inlet port of the fuel transfer pump opens in order to allow the flow of fuel into the pump. After the fuel flow has stopped, the inlet check valve closes in order to prevent fuel flow out of the inlet port. Fuel flows from the inlet port in the pump to the outlet port, which also has a check valve. The outlet check valve opens in order to allow pressurized fuel flow out of the pump. The outlet check valve closes in order to prevent pressurized fuel leakage back through the pump.

Fuel flows from the outlet port of fuel transfer pump (35) to the fuel supply passage in the cylinder head. The fuel supply passage is a drilled hole which begins at the front of the cylinder head. The fuel supply passage extends to the back of the cylinder head. This passage connects with each unit injector bore in order to supply fuel to unit injectors (7). Fuel from the transfer pump flows through the cylinder head to all of the unit injectors. Excess fuel flows out of the back of the cylinder head. After the excess flows out of the back of the cylinder head, the fuel flows into fuel pressure regulator (9).

Fuel pressure regulator (9) consists of an orifice and a spring loaded check valve. The orifice is a flow restriction that pressurizes the supply fuel. The spring loaded check valve opens at 35 kPa (5 psi) in order to allow the fuel which has flowed through the orifice to return to fuel tank (12). When the engine is off and no fuel pressure is present, the spring loaded check valve closes. The spring loaded check valve closes in order to prevent the fuel in the cylinder head from draining back to the fuel tank.

# Injection Actuation System

## Actuation Oil Flow

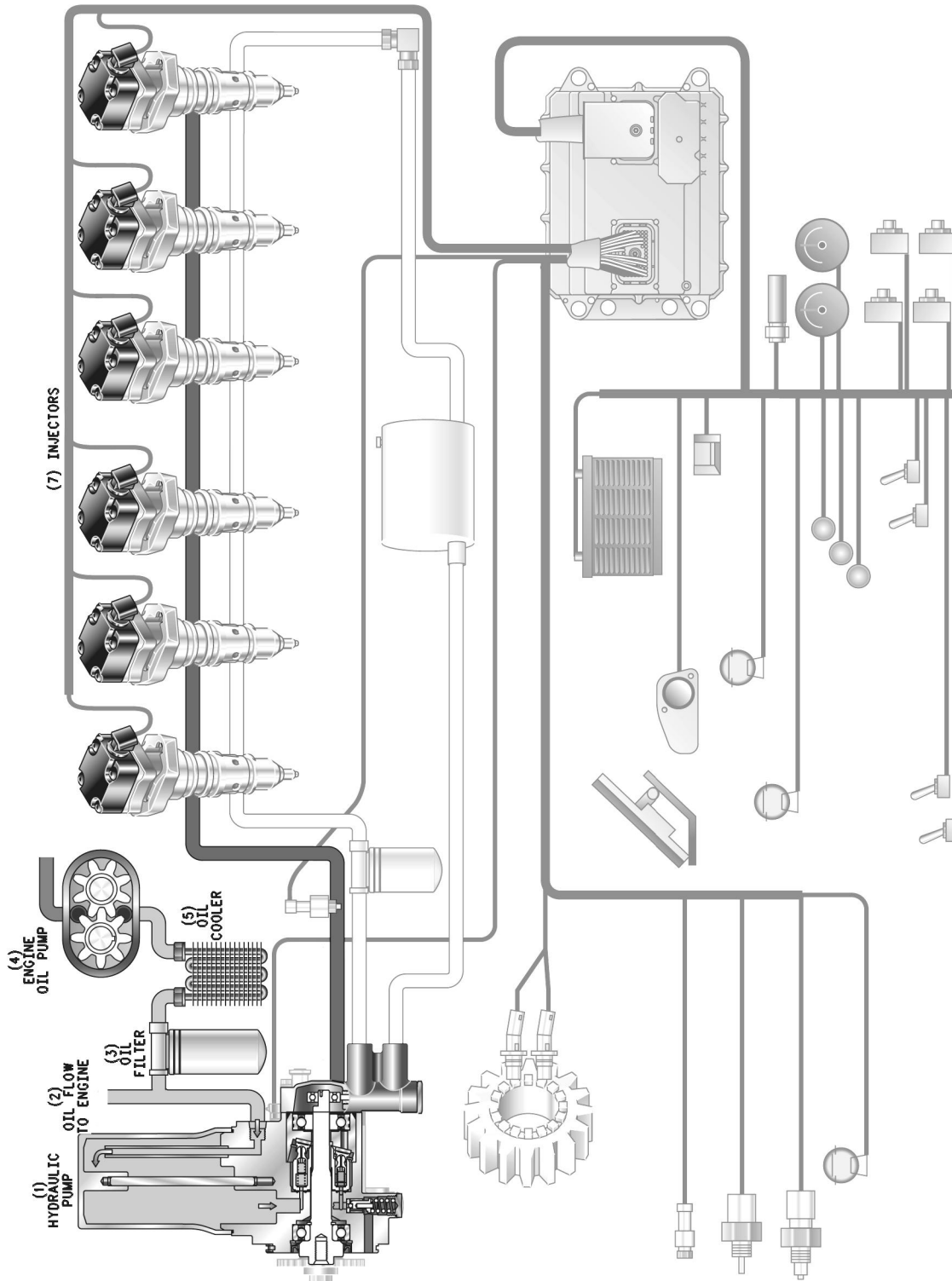

Illustration 5

Flow path of the injection actuation oil

- (1) Unit injector hydraulic pump
- (2) Oil flow to engine

- (3) Oil filter
- (4) Engine oil pump

- (5) Oil cooler
- (7) Injectors

The injection actuation system serves two functions. The injection actuation system supplies high pressure oil in order to power HEUI injectors (7). Also, the injection actuation system controls the injection pressure that is produced by the unit injectors by changing the actuation pressure of the oil.

The injection actuation system consists of five basic components:

- Engine oil pump (4)
- Engine oil filter (3)
- Unit injector hydraulic pump (1)
- Injection actuation pressure control valve (IAP Control Valve) (10)
- Injection actuation pressure sensor (IAP Sensor) (6)

Oil from engine oil pump (4) supplies the needs of the engine lubrication system. Also, oil from the engine oil pump supplies the needs of unit injector hydraulic pump (1) for the fuel system. The capacity of the engine oil pump has been increased in order to meet the additional flow requirement that is necessary.

Oil that is drawn from the sump is pressurized to the lubrication system oil pressure by engine oil pump (4). Oil flows from the engine oil pump through engine oil cooler (5), through engine oil filter (3), and then to the main oil gallery. A separate circuit from the main oil gallery directs a portion of the lubrication oil in order to supply unit injector hydraulic pump (1). A steel tube on the left side of the engine connects the main oil gallery with the inlet port of the unit injector hydraulic pump.

Oil flows into the inlet port of unit injector hydraulic pump (1) and the oil fills the pump reservoir. The pump reservoir provides oil to the unit injector hydraulic pump during start-up. Also, the pump reservoir provides oil to the unit injector hydraulic pump until the engine oil pump can increase pressure.

The pump reservoir also provides makeup oil to the high pressure oil passage in the cylinder head. When the engine is off and the engine cools down, the oil shrinks. A check valve in the pump allows oil to be drawn from the pump reservoir in order to keep the high pressure oil passage full.

Oil from the pump reservoir is pressurized in unit injector hydraulic pump (1) and the oil is pushed out of the outlet port of the pump under high pressure. Oil then flows from the outlet port of the unit injector hydraulic pump to the high pressure oil passage in the cylinder head.

The high pressure oil passage connects with each unit injector bore in order to supply high pressure actuation oil to unit injectors (7). Actuation oil that is under high pressure flows from unit injector hydraulic pump (1) through the cylinder head to all of the injectors. Oil is contained in the high pressure oil passage until the oil is used by the unit injectors. Oil that has been exhausted by the unit injectors is expelled under the valve covers. This oil returns to the crankcase through oil drain holes in the cylinder head.

Actuation Oil Pressure Control

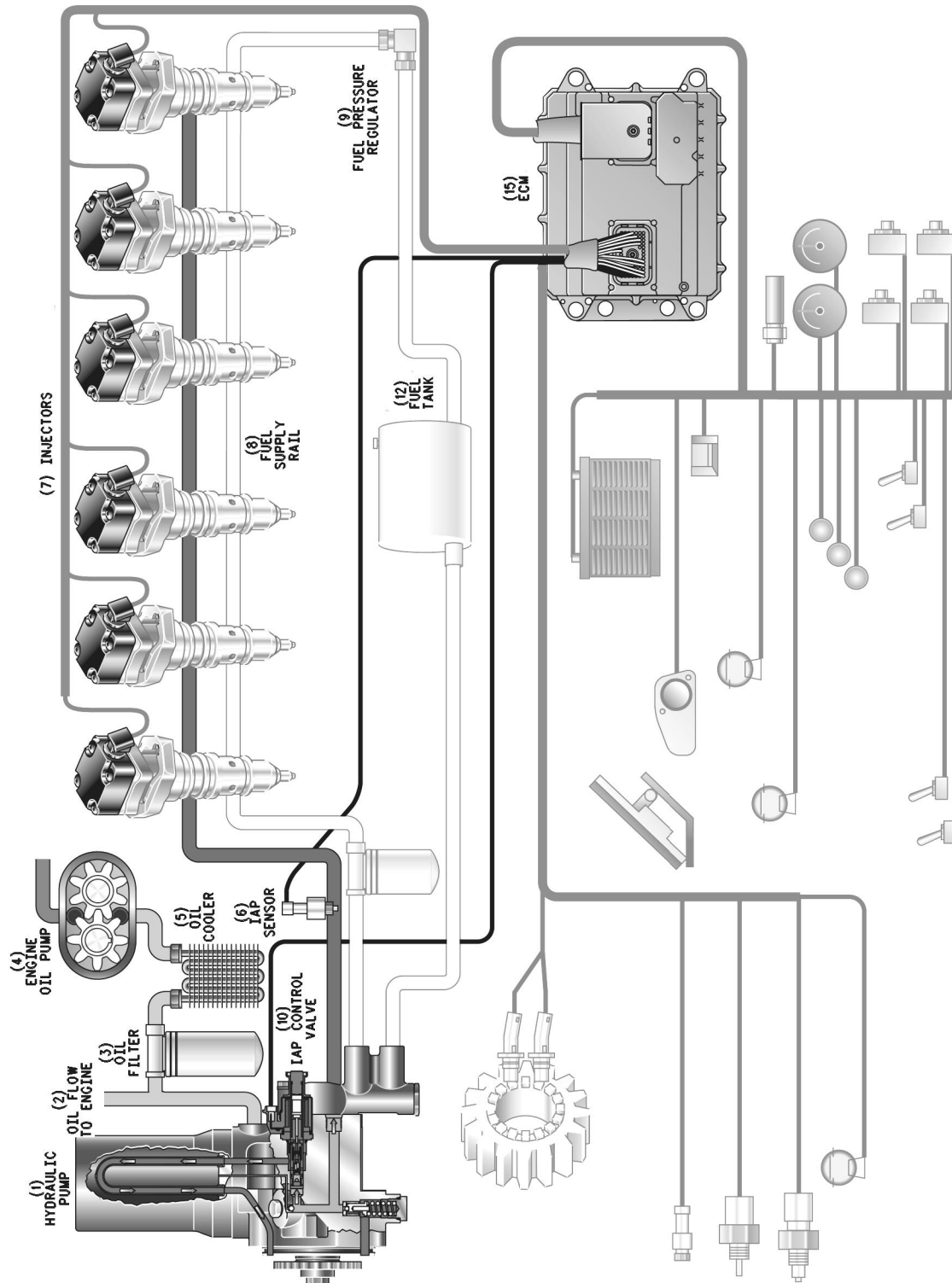

Illustration 6

Injection Actuation Oil Pressure Control

- |                                  |                      |                             |
|----------------------------------|----------------------|-----------------------------|
| (1) Unit injector hydraulic pump | (5) Oil cooler       | (9) Fuel pressure regulator |
| (2) Oil flow to engine           | (6) IAP sensor       | (10) IAP control valve      |
| (3) Oil filter                   | (7) Injectors        | (12) Fuel tank              |
| (4) Engine oil pump              | (8) Fuel supply rail | (15) ECM                    |

Unit injector hydraulic pump (1) is a fixed displacement axial piston pump. The pump is designed in order to generate adequate flow under the conditions that are the most demanding.

Under most operating conditions, unit injector hydraulic pump (1) is producing excess flow. This excess flow must be discharged to a drain in order to control the system's pressure. IAP Control Valve (10) regulates system pressure by discharging the precise amount of oil to the drain. This discharging of oil is required in order to maintain the desired actuation pressure.

There are two types of actuation pressure:

- Desired actuation pressure
- Actual actuation pressure

Desired actuation pressure is the injection actuation pressure that is required by the system for optimum engine performance. The desired actuation pressure is established by the performance maps in ECM (15). The ECM selects the desired actuation pressure. The ECM bases the selection on the signal inputs from many sensors. Some of the sensors that are supplying signal inputs to the ECM are accelerator pedal position sensor (18), boost pressure sensor (16), speed/timing sensors (14), and coolant temperature sensor (20). The desired actuation pressure is constantly changing due to changing engine speed and due to changing engine load. The desired actuation pressure is only constant under steady state conditions (steady engine speed and load).

Actual actuation pressure is the actual system pressure of the actuation oil that is powering the injectors (7). IAP Control Valve (10) is constantly changing the amount of pump flow that is discharged to the drain. The pump flow is discharged to the drain in order to match the actual actuation pressure to the desired actuation pressure.

Three components operate together in order to control injection actuation pressure:

- ECM (15)
- IAP Control Valve (10)
- IAP Sensor (6)

ECM (15) selects the desired actuation pressure. The desired actuation pressure is based on both the sensor input and the performance maps. The ECM sends a control current to IAP Control Valve (10) in order to change the actual actuation pressure. The IAP Control Valve reacts to the electrical current from the ECM in order to change the actual actuation pressure. The actual actuation pressure is changed when the IAP Control Valve discharges pump flow to the drain. The IAP Control Valve acts as an electrically controlled relief valve. IAP Sensor (6) monitors the actual actuation pressure in the high pressure oil passage. The IAP Sensor reports the actual actuation pressure to the ECM by sending a signal voltage to the ECM.

The injection actuation pressure control system operates in a cycle. ECM (15) selects the desired actuation pressure. Then, the ECM sends an electrical current to IAP Control Valve (10) that should produce that pressure. The IAP Control Valve reacts to the electrical current from the ECM by changing the pressure relief setting, which changes the actual actuation pressure. IAP Sensor (6) monitors the actual actuation pressure and the IAP Sensor sends a signal voltage back to the ECM. The ECM interprets the signal voltage from the IAP Sensor in order to calculate the actual actuation pressure. Then, the ECM compares the actual actuation pressure to the desired actuation pressure in order to adjust the electrical current to the IAP Control Valve. The IAP Control Valve responds to the change in electrical current by changing the actual actuation pressure. This process is repeated 67 times per second. This cycle of constant repetition is called a closed loop control system.

Most of the high pressure oil flow from unit injector hydraulic pump (1) is used in order to power unit injectors (7). Excess flow is the amount of pump flow that is not required in order to meet the desired actuation pressure. The excess flow is returned to the drain through IAP Control Valve (10). Excess flow from the IAP Control Valve flows upward through a U-shaped tube in the pump reservoir. The excess flow travels through a drilled passage to the front of the pump. Drain oil flows out of the front of the pump over the pump drive gear and flows down the engine front gear train to sump.

## Operation of the Injection Actuation Pressure Control Valve

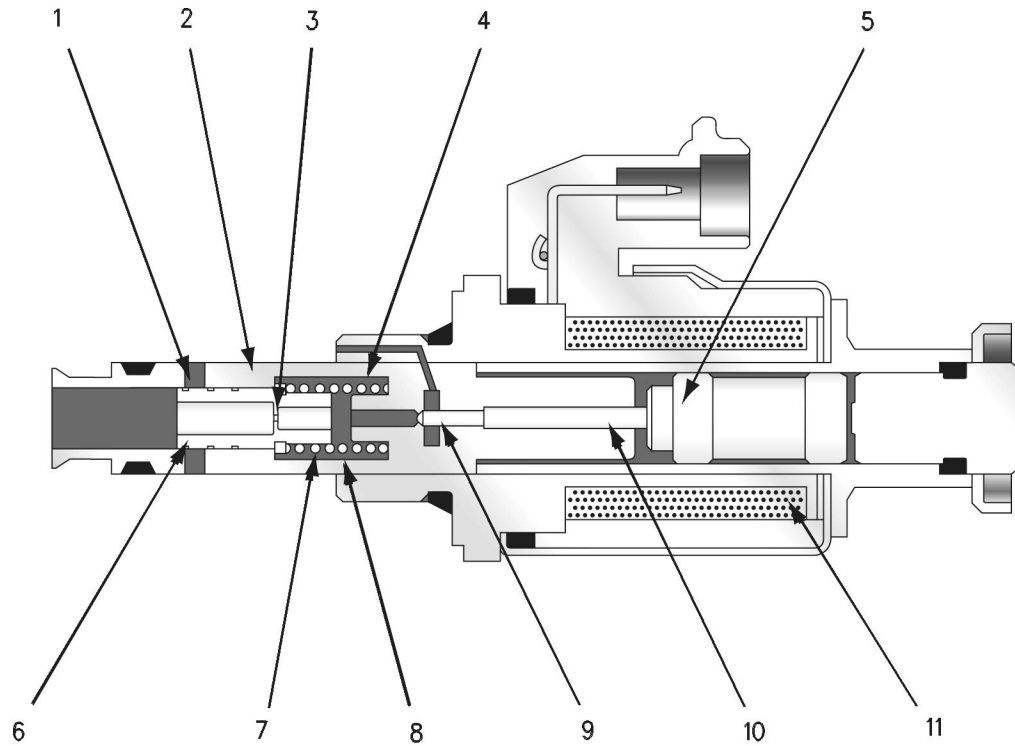

Illustration 7

g00295335

Injection actuation pressure control valve

- (1) Drain port
- (2) Valve body
- (3) Control orifice
- (4) Spool chamber

- (5) Armature
- (6) Valve spool
- (7) Spool spring
- (8) Reduced pressure oil

- (9) Poppet
- (10) Push pin
- (11) Solenoid

The IAP Control Valve is an electrically controlled pilot operated pressure control valve. The Injection Actuation Pressure Control Valve is used in order to maintain selected actuation system pressure. The selected actuation system pressure is maintained regardless of engine speed, pump flow, and variable oil demand of the unit injectors. The IAP Control Valve consists of six basic components:

- Armature (5)
- Valve spool (6)
- Spool spring (7)
- Poppet (9)

- Push pin (10)
- Solenoid (11)

The IAP Control Valve operates by using a variable electrical current from the ECM in order to create a magnetic field in the solenoid (11). This magnetic field acts on armature (5) and the magnetic field generates a mechanical force. This mechanical force pushes armature (5) to the left. The mechanical force travels through push pin (10) to poppet (9).



The magnetic force that is holding poppet (9) closed is opposed by reduced hydraulic pressure inside the spool chamber. The reduced hydraulic pressure inside the spool chamber is trying to open poppet (9). This reduced hydraulic pressure increases until the reduced hydraulic pressure overcomes the mechanical force of solenoid (11). When the reduced hydraulic pressure overcomes the mechanical force of solenoid (11), poppet (9) opens. The open poppet allows a flow path to drain for some of the reduced pressure oil (8). Discharging part of reduced pressure oil (8) to drain lowers the hydraulic pressure. When the hydraulic pressure of reduced pressure oil (8) decreases below the magnetic force on poppet (9), the poppet closes again.

### Valve Operation for ENGINE OFF

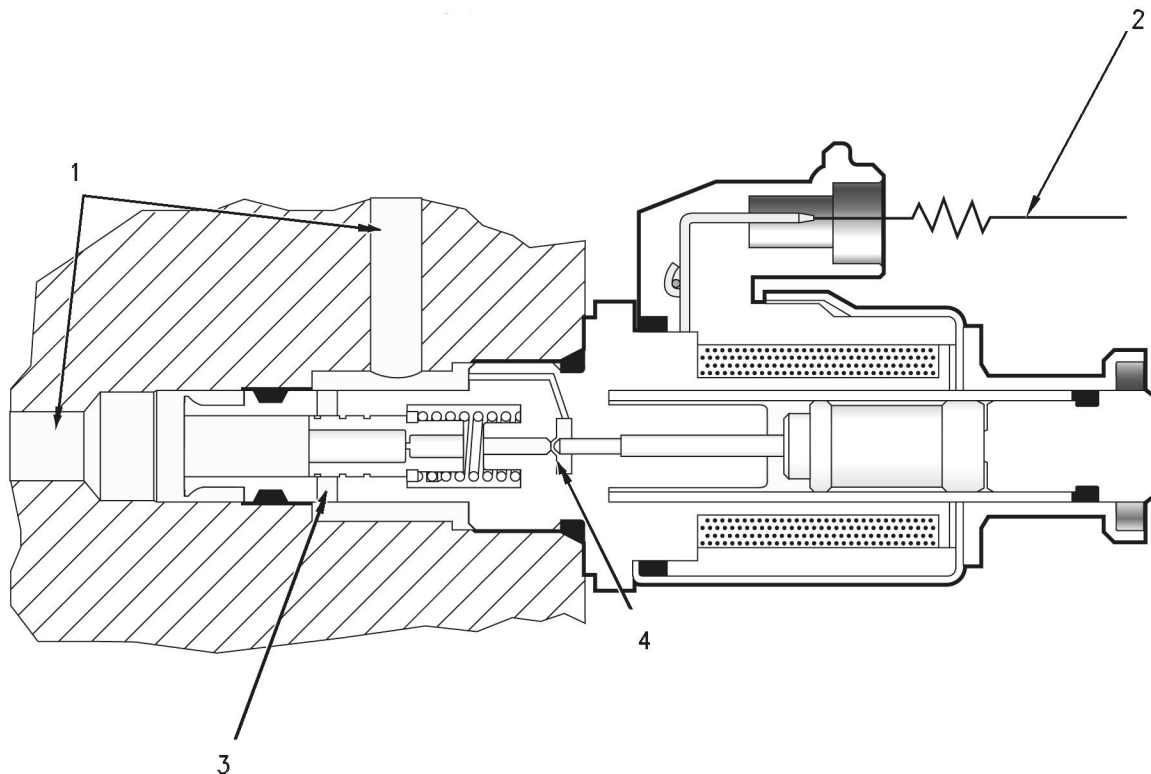

Illustration 8

g00295336

Operation of the injection actuation pressure control valve (engine off)

- |                                 |                            |
|---------------------------------|----------------------------|
| (1) Pump outlet pressure (none) | (3) Closed drain port      |
| (2) Current from ECM (none)     | (4) Poppet (open position) |

When the engine is off, there is no pump outlet pressure (1) from the pump and there is no current to the solenoid from the ECM (2). The spool spring pushes the spool valve completely to the left. When the spool spring pushes the spool valve completely to the left, drain port (3) is completely blocked.

## Valve Operation for ENGINE CRANKING

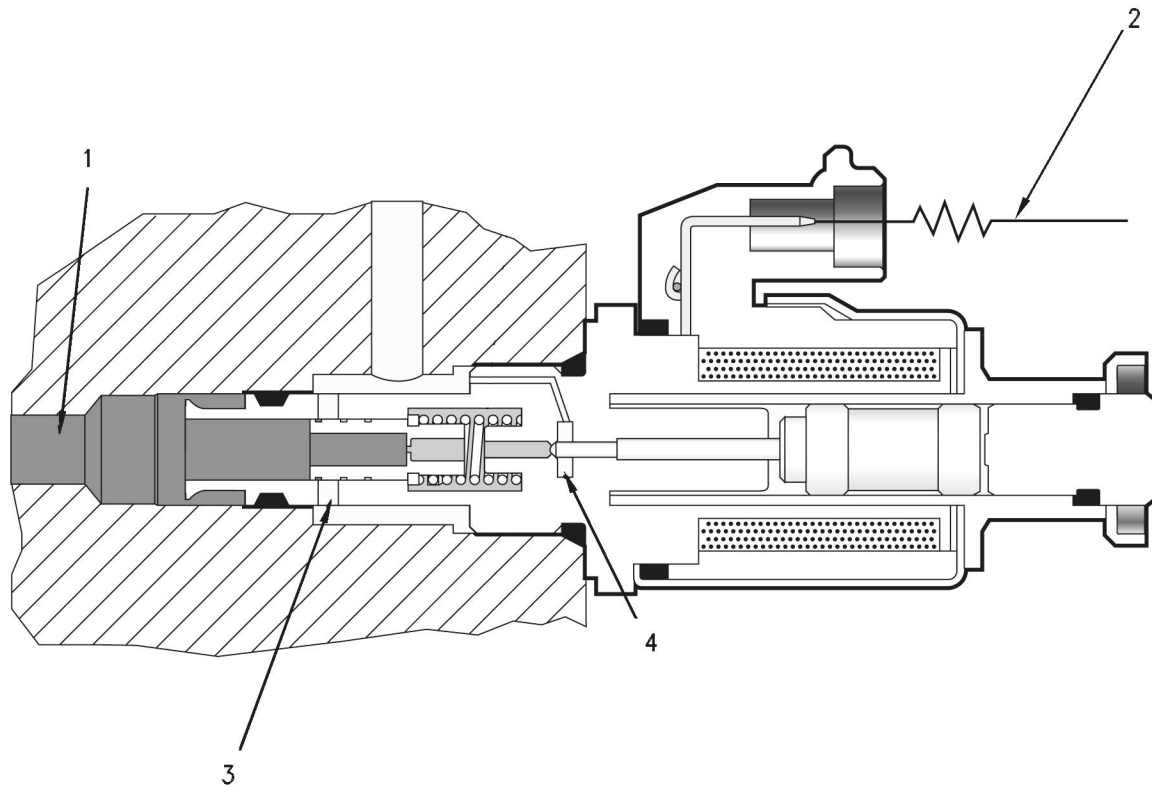

Illustration 9

g00295337

Operation of the injection actuation pressure control valve (engine cranking)

- |                          |                                   |
|--------------------------|-----------------------------------|
| (1) Pump outlet pressure | (3) Drain port (blocked position) |
| (2) Current from the ECM | (4) Poppet (closed position)      |

During engine start-up, approximately 6 MPa (870 psi) of injection actuation pressure is required in order to activate the unit injector. This low injection actuation pressure generates a low fuel injection pressure of about 35 MPa (5000 psi). This low fuel injection pressure aids cold starting.

In order to start the engine quickly, the injection actuation pressure must rise quickly. Because the unit injector hydraulic pump is being turned at engine cranking speed, pump flow is very low. The ECM sends a strong current (2) to the IAP Control Valve in order to keep the spool closed. With the spool in the closed position, all of the flow to drain port (3) is blocked. The flow to drain port (3) remains blocked until the actual actuation pressure of 6 MPa (870 psi) is reached. The unit injectors are not fired until the 6 MPa (870 psi) actual actuation pressure is reached.

**Note:** If the engine is already warm, the pressure that is required to start the engine may be higher than 6 MPa (870 psi). The values for the desired actuation pressures are stored in the performance maps of the ECM. The values for desired actuation pressures vary with engine temperature.

Once the unit injectors begin to operate, the ECM controls the current to the IAP Control Valve. The ECM and the IAP Control Valve maintain the actual actuation pressure at 6 MPa (870 psi) until the engine starts. The ECM monitors the actual actuation pressure through the IAP Sensor that is located in the high pressure oil manifold. The ECM establishes desired actuation pressure by monitoring several electrical input signals and the ECM sends a predetermined current to the IAP Control Valve. The ECM also compares the desired actuation pressure to the actual actuation pressure in the high pressure oil passage. The ECM adjusts the current levels to the IAP Control Valve in order to make the actual actuation pressure equal to the desired actuation pressure.

### **Oil Flow for ENGINE CRANKING**

Pump outlet pressure (1) enters the end of the valve body and pump outlet pressure acts against the valve spool. The pump outlet pressure tries to push the valve spool to the right (open). A small amount of oil also flows through the center of the spool, through the spool control orifice and into the spool spring chamber. The current from the ECM (2) causes the solenoid to generate a magnetic field which pushes the armature to the left. The armature exerts a force on the push pin and the poppet which holds the poppet closed. The poppet is the only path to the drain for the oil in the spool spring chamber. Pump outlet pressure (1) flows through the spool control orifice and into the spool spring chamber. This flow of pump outlet pressure allows spring chamber pressure to build up. Because the spring chamber path to the drain is blocked by the poppet, the pressure in the spring chamber is equal to pump outlet pressure (1).

The combination of spool spring force and spring chamber pressure hold the spool to the left. When the spool is held to the left, the drain ports are closed. All pump flow is directed to the high pressure oil manifold until an actual actuation pressure of 6 MPa (870 psi) is reached.

## Valve Operation for RUNNING ENGINE

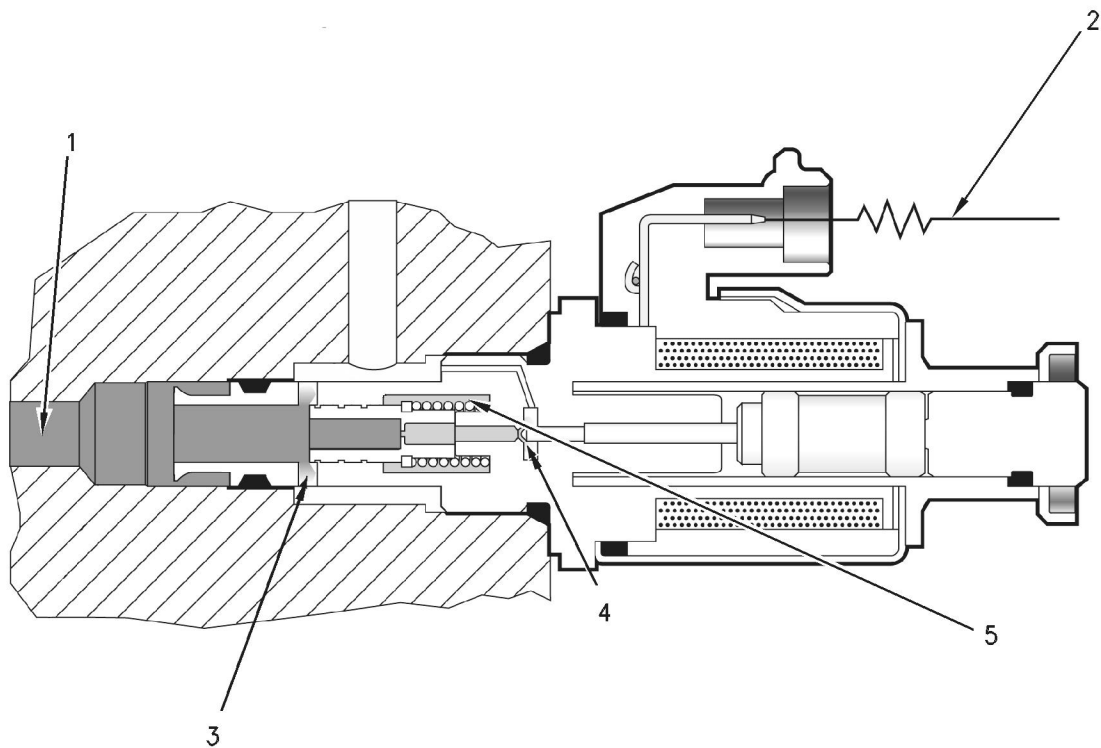

Illustration 10

g00295338

Operation of the injection actuation pressure control valve (running engine)

(1) Pump outlet pressure  
(2) Current from the ECM

(3) Drain port (open)  
(4) Poppet (open)

(5) Reduced pressure oil

Once the engine starts, the ECM controls the current (2) to the IAP Control Valve in order to maintain the desired actuation pressure. The IAP Sensor monitors the actual actuation pressure in the high pressure oil passage in the cylinder head. The ECM compares the actual actuation pressure to the desired actuation pressure 67 times per second. When these pressures do not match, the ECM adjusts the current levels (2) to the IAP Control Valve in order to make the actual injection actuation pressure equal to the desired injection actuation pressure.

The amount of current that is sent to the solenoid regulates the amount of magnetic force that is trying to hold the poppet closed. The solenoid, the armature and the push pin simulate a variable spring that is electronically controlled. Increased current results in increased force. Decreased current results in decreased force.

The magnetic force that is applied to the poppet holds the poppet closed. When the poppet is closed, the pressure in the spool spring chamber increases. When the pressure in the spool spring chamber exceeds the magnetic force that is holding the poppet closed, the poppet (4) will move to the right. When the poppet (4) moves to the right, some of the pressure oil in the spool spring chamber escapes to the drain. This causes the pressure in the spring chamber to drop. When the pressure in the spring chamber drops, the poppet closes. When the poppet closes, the pressure again begins to increase and the cycle is repeated. This process controls the reduced pressure oil (5) in the spool spring cavity. The reduced pressure oil (5) in the spool spring cavity acts on the spool. The reduced pressure oil (5) in the spool spring cavity tries to move the spool to the left. When the spool is moved to the left, the drain port (3) is blocked.

The combined force of the mechanical spring and reduced pressure oil in the spool spring chamber try to move the spool to the left in order to block the drain port (3). When the drain port is blocked, pump outlet pressure (1) rises and the increased pump outlet pressure moves the spool to the right (open).

Because the mechanical spring has a fixed spring rate, the reduced pressure oil (5) in the spool must be adjusted in order to control pump outlet pressure (1). The reduced pressure oil (5) in the spool can be raised in order to control pump outlet pressure (1) or the reduced pressure oil (5) in the spool can be lowered in order to control pump outlet pressure (1). The reduced pressure oil (5) is controlled by the amount of electrical current from the ECM (2). Most of the time, the poppet and the spool operate in a partially open position. The poppet and the spool are completely open or completely closed only during the following conditions:

- Acceleration
- Deceleration
- Rapidly changing engine loads

#### **Oil Flow for RUNNING ENGINE**

When pump outlet pressure (1) enters the end of the valve body, a small amount of oil flows into the spool spring chamber through the control orifice in the spool. The pressure in the spool spring chamber is controlled by adjusting the force on the poppet (4). Adjusting the force on the poppet (4) allows the poppet to drain off some of the oil in the spool spring chamber. The force on the poppet is controlled by the strength of the magnetic field that is produced from the electrical current from the ECM (2). The spool responds to pressure changes in the spool spring chamber. The spool changes positions in order to balance the force on the spool. The spool tries to make the force on the right side of the spool equal to the force on the left side of the spool. The spool position dictates the amount of the surface area of the drain ports (3) that is open.

The open area of the drain port controls the amount of oil that is drained off from the pump outlet. The oil is drained off from the pump outlet in order to maintain the desired actuation pressure. The process of responding to pressure changes on either side of the spool occurs so rapidly that the spool is held in a partially open position and pump outlet pressure (1) is closely controlled. The IAP Control Valve allows infinitely variable control of pump outlet pressure (1) between 6 MPa (870 psi) and 27.5 MPa (4000 psi).

## **Components of the HEUI Injector**

The HEUI injector serves four functions. The HEUI injector pressurizes supply fuel from 450 kPa (65 psi) to 162 MPa (23500 psi). The HEUI injector functions as an atomizer by pumping high pressure fuel through orifice holes in the unit injector tip. The HEUI injector delivers the correct amount of atomized fuel into the combustion chamber and the HEUI injector disperses the atomized fuel evenly throughout the combustion chamber.

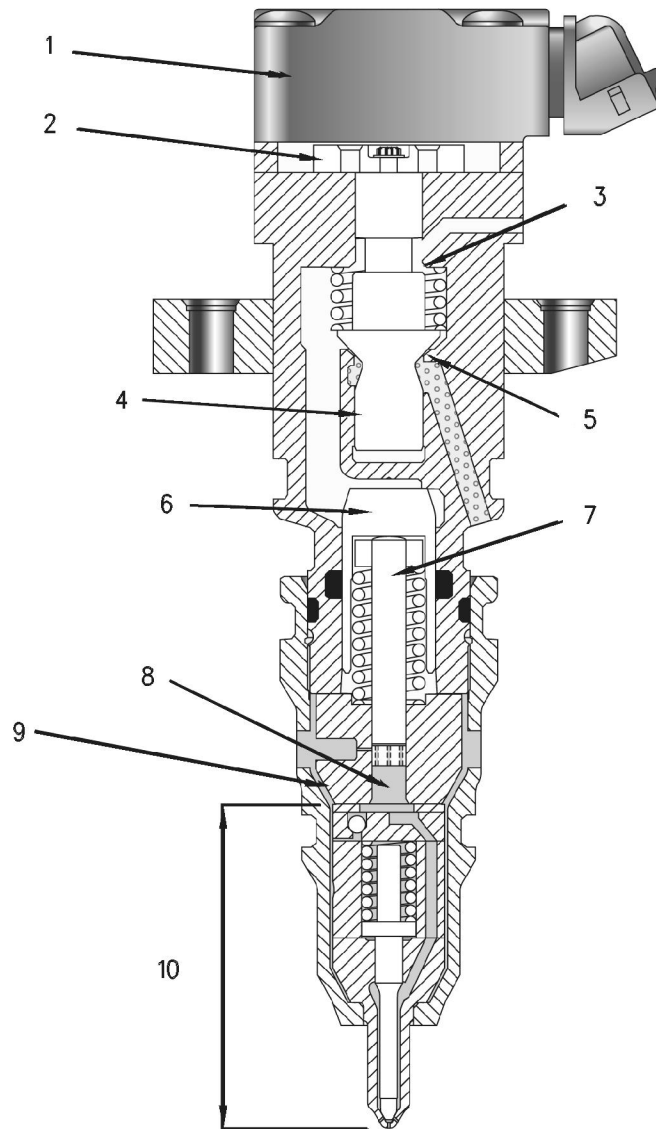

Illustration 11

g00295359

Component of the HEUI injector

- |                       |                        |
|-----------------------|------------------------|
| (1) Solenoid          | (6) Intensifier piston |
| (2) Armature          | (7) Plunger            |
| (3) Upper poppet seat | (8) Plunger cavity     |
| (4) Poppet valve      | (9) Barrel             |
| (5) Lower poppet seat | (10) Nozzle assembly   |

The HEUI injector consists of five basic components:

- Solenoid (1)
- Poppet valve (4)
- Intensifier piston (6) and plunger (7)
- Barrel (9)
- Nozzle assembly (10)

## Solenoid

The solenoid (1) is an electromagnet. When the solenoid is energized, the solenoid creates a very strong magnetic field. This magnetic field attracts the armature (2) which is connected to the poppet valve (4) by an armature screw. When the armature moves toward the solenoid, the armature lifts the poppet valve off the poppet valve's lower seat (5). Energizing the solenoid and lifting the poppet valve off the poppet valve's lower seat is the beginning of the fuel injection process.

## Poppet Valve

The poppet valve (4) has two positions which are opened and closed. In the closed position, the poppet is held on the lower poppet seat (5) by a spring. The closed lower poppet seat prevents high pressure actuation oil from entering the unit injector. The open upper poppet seat (3) vents oil in the cavity that is above the intensifier piston (6) to the atmosphere. The oil is vented to the atmosphere through the upper portion of the unit injector. In the open position, the solenoid (1) is energized and the poppet valve is lifted off the poppet valve's lower seat. When the poppet valve is lifted off the poppet valve's lower seat, the lower poppet seat opens allowing high pressure actuation oil to enter the unit injector. When the high pressure actuation oil enters the unit injector, the high pressure actuation oil pushes on the top of intensifier piston (6). The upper poppet seat (3) of poppet valve (4) closes and upper poppet seat (3) of poppet valve (4) blocks the path to the drain. Blocking the path to the drain prevents the leakage of high pressure actuation oil from the unit injector.

## Intensifier Piston

The surface area of intensifier piston (6) is six times larger than the surface area of plunger (7). This larger surface area provides a multiplication of force. This multiplication of force allows 27.5 MPa (4000 psi) of actuation oil to produce 162 MPa (23500 psi) of fuel injection pressure. When poppet valve (4) moves away from lower poppet seat (5), high pressure actuation oil enters the unit injector. When the high pressure actuation oil enters the unit injector, the high pressure actuation oil pushes on the top of intensifier piston (6). Pressure rises on top of the intensifier piston and the pressure pushes down on intensifier piston (6) and plunger (7). The downward movement of the plunger pressurizes the fuel in plunger cavity (8). The pressurized fuel in the plunger cavity causes nozzle assembly (10) to open. When the nozzle assembly opens, the fuel delivery into the combustion chamber begins. A large O-ring around the intensifier piston separates the oil above the intensifier piston from the fuel below the intensifier piston.

## Barrel

The barrel (9) is the cylinder that holds plunger (7). The plunger moves inside the barrel. The plunger and barrel together act as a pump. Both the plunger and the barrel are precision components that have a working clearance of only 0.0025 mm (.00010 inch). These tight clearances are required in order to produce injection pressures over 162 MPa (23500 psi) without excessive leakage.

**Note:** A small amount of controlled leakage is required in order to lubricate the plunger which prevents wear.

The barrel (9) also contains the PRIME spill port.

The PRIME spill port is a small hole with a high precision tolerance. The PRIME spill port is machined through the side of barrel (9) into plunger (7). This port momentarily vents fuel injection pressure during the downward stroke of the plunger.

## Nozzle Assembly

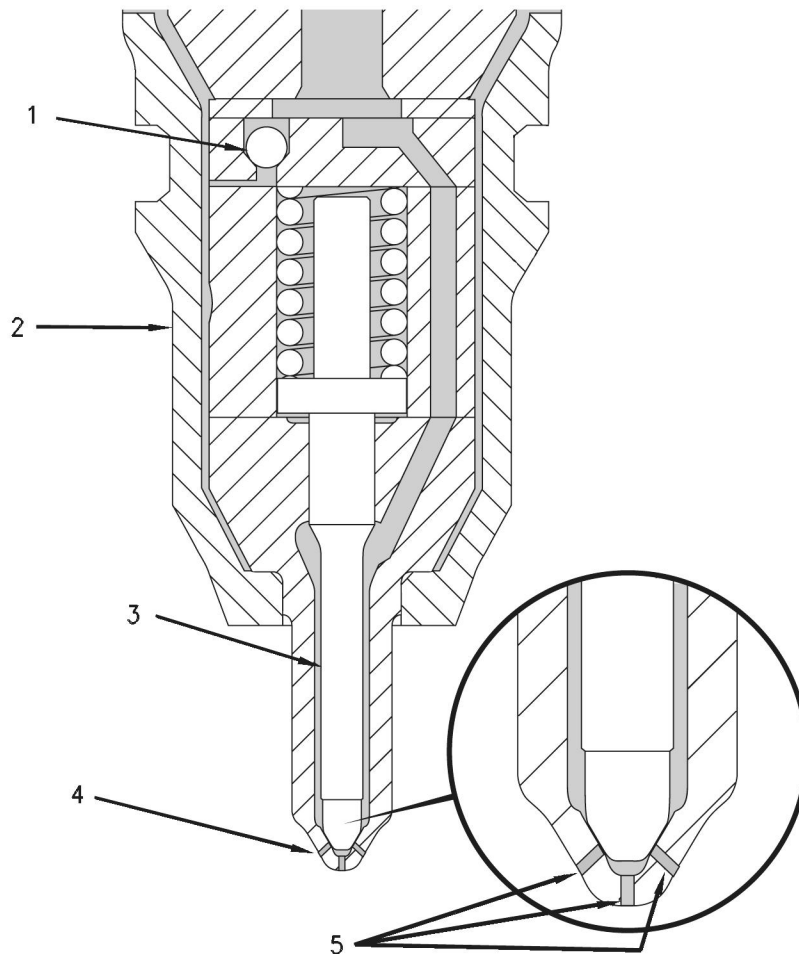

Illustration 12

g00295360

### Nozzle assembly

(1) Inlet fill check ball  
(2) Case

(3) Check  
(4) Tip

(5) Tip orifice holes

The nozzle assembly is similar to all other unit injector's nozzle assemblies. Fuel that has been pressurized to the injection pressure flows from the plunger cavity through a passage in the nozzle to the nozzle tip (4). Fuel flow out of the tip is stopped by check (3), which covers the tip orifice holes (5) in the end of the tip (4). The force of a spring holds the check down in the closed position. This prevents the leakage of fuel out of tip (4) and this prevents the leakage of combustion gas into the unit injector when the cylinder fires.



When the injection pressure increases to approximately 28 MPa (4000 psi), the hydraulic force that is pushing on check (3) becomes greater than the spring force that is holding the check down. When the spring force is overcome by the hydraulic force, the check moves away from tip (4). When the check moves away from the tip, the check is in the open position. The amount of pressure that is required to open the check is called the Valve Opening Pressure (VOP). The fuel flows out of tip orifice holes (5) in the end of the tip and the fuel flows into the combustion chamber. The check remains open and fuel continues to flow out of the tip until fuel injection pressure drops below 28 MPa (4000 psi). When the pressure drops, the check closes and fuel injection is stopped. The amount of pressure that allows the check to close is called the Valve Closing Pressure (VCP).

**Note:** Valve Opening Pressures (VOP) and Valve Closing Pressures (VCP) vary among applications and horsepower ratings in order to meet exhaust emission standards. The above values were used as illustrations only.

The inlet fill check ball (1) unseats during upward travel of the plunger in order to allow the plunger cavity to refill. The inlet fill check ball seats during the downward stroke of the plunger and the inlet fill check ball seals during the downward stroke of the plunger. The inlet fill check ball seals during the downward stroke of the plunger in order to prevent fuel injection pressure leakage into the fuel supply.

## Operation of the HEUI Fuel Injector

There are five stages of injection with the HEUI injector:

- Pre-injection
- Pilot injection
- Delay
- Main injection
- End of injection

## Pre-Injection

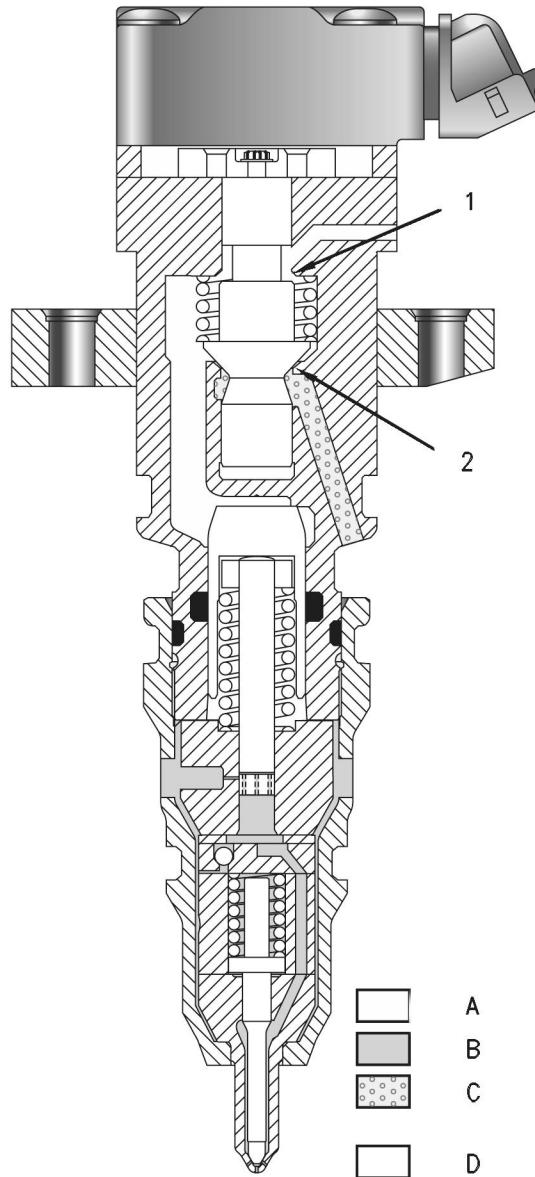

Illustration 13  
HEUI injector (Pre-injection)

g00295361

(1) Upper poppet seat (open position)  
(2) Closed lower poppet seat

(A) Drain (atmosphere)  
(B) Fuel supply pressure

(C) Actuation oil pressure  
(D) Moving parts

All of the internal components have been returned to the spring loaded position during the pre-injection. The solenoid is not energized and the lower poppet seat (2) is closed. When the lower poppet seat is closed, the lower poppet seat blocks high pressure actuation oil from entering the unit injector. The plunger and the intensifier piston are at the top of the bore and the plunger cavity is full of fuel. Fuel pressure in the plunger cavity is equal to the fuel supply pressure. The fuel supply pressure is approximately 450 kPa (65 psi).

## Pilot Injection

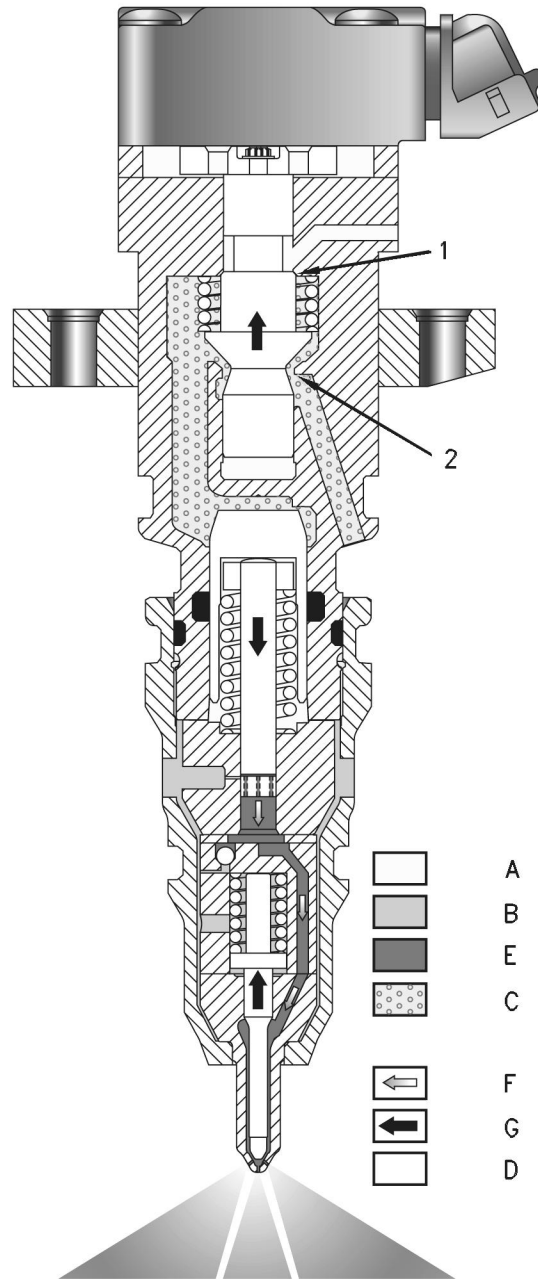

Illustration 14

g00295362

HEUI injector (Pilot Injection)

- (1) Upper poppet seat (closed position)
- (2) Lower poppet seat (open position)
- (A) Drain (atmosphere)

- (B) Fuel supply pressure
- (C) Actuation oil pressure
- (D) Moving parts

- (E) Injection pressure
- (F) Fuel flow
- (G) Mechanical movement

When the ECM activates the unit injector, the ECM sends a current to the unit injector solenoid. The current causes the solenoid to produce a strong magnetic field which creates a pull on the armature. The armature is mechanically connected to the poppet valve by a screw. The magnetic pull of the solenoid overcomes the spring tension that is holding the poppet valve closed. When the poppet valve opens, the poppet moves away from the lower poppet seat.

When the poppet valve opens, the upper poppet seat (1) blocks the path to the drain and the lower poppet seat (2) opens the poppet chamber to incoming high pressure actuation oil. High pressure oil flows around the poppet. The high pressure oil flows through a passage onto the top of the intensifier piston. High pressure oil acts on the top of the intensifier piston. The piston and the plunger are pushed down by the high pressure oil. The downward movement of the plunger pressurizes the fuel in the plunger cavity and nozzle assembly. When the pressure reaches Valve Opening Pressure (VOP) of approximately 28 MPa (4000 psi), the check lifts up from the seat in the tip. When the check lifts up from the seat in the tip, injection begins.

### **Pre-Injection Metering (PRIME)**

The 3126B and 3126E diesel engine's fuel system has a unique feature that is called PRIME. Pre-Injection Metering (PRIME) is a feature that offers a significant benefit in lower emissions. Also, PRIME offers a significant benefit in reducing combustion noise. While other fuel systems deliver a single large quantity of fuel into the combustion chamber, PRIME injectors break the delivery into two separate quantities. The first quantity is a small pilot injection which is followed by a short delay. Then, the injector delivers a large main injection. The pilot injection is not intended to produce power. The pilot injection is intended to establish a flame front. The pilot injection will help the larger main injection burn more completely and the pilot injection will help the larger main injection burn in a controlled manner.

Under certain engine operating conditions, when fuel is delivered in one large injection, the fuel tends to explode rather than burn in a controlled manner. This results in engine knock. When fuel explodes rather than burns in a controlled manner, engine knock and excess NOx emissions result.

The PRIME feature produces a small pilot injection that is followed by a brief delay. The brief delay gives the pilot injection the time that is required to start burning. The main injection follows the pilot injection and the main injection is delivered into the flame front that was established by the pilot injection. The main injection is immediately ignited. The main injection burns smoothly and the main injection burns completely. This complete combustion significantly reduces particulate emission (soot) and NOx. This complete combustion also reduces combustion noise from the engine up to 50 percent. This reduction of combustion noise from the engine results in noticeably quieter engine operation. The actual operation of PRIME is described in the following information.

## Injection Delay

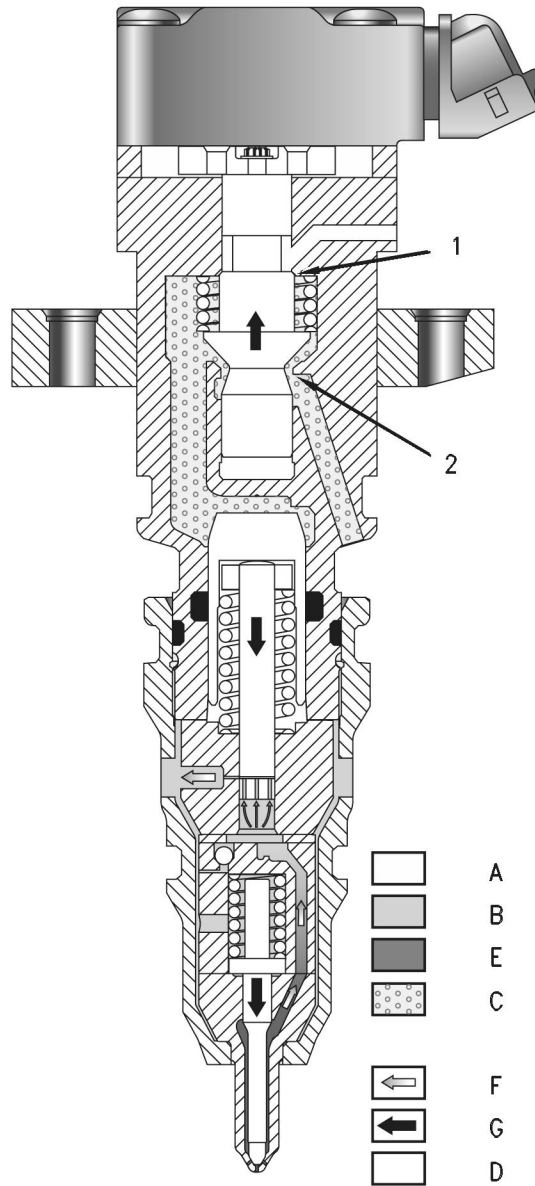

Illustration 15  
HEUI injector delay

g00295363

(1) Upper poppet seat (closed position)  
(2) Lower poppet seat (open position)  
(A) Drain (atmosphere)

(B) Fuel supply pressure  
(C) Actuation oil pressure  
(D) Moving parts

(E) Injection pressure  
(F) Fuel flow  
(G) Mechanical movement

The plunger continues moving downward and the plunger continues to inject fuel into the combustion chamber. Until the PRIME groove in the plunger lines up with the PRIME spill port in the barrel, the plunger continues to inject fuel into the combustion chamber. When the groove in the plunger aligns with the spill port, high pressure fuel under the plunger can flow upward. The high pressure fuel flows through three holes in the bottom of the plunger. Then, the high pressure fuel flows out of the groove of the plunger and the spill port and the fuel flows back into the fuel supply passage. This loss of high pressure fuel causes injection pressure to drop below Valve Closing Pressure (VCP). The spring force overcomes the hydraulic force of the reduced injection pressure. When the spring force overcomes the hydraulic force of the reduced injection pressure, the check closes and fuel injection stops. This is the end of the pilot injection and the start of the short injection delay period.

## Main Injection

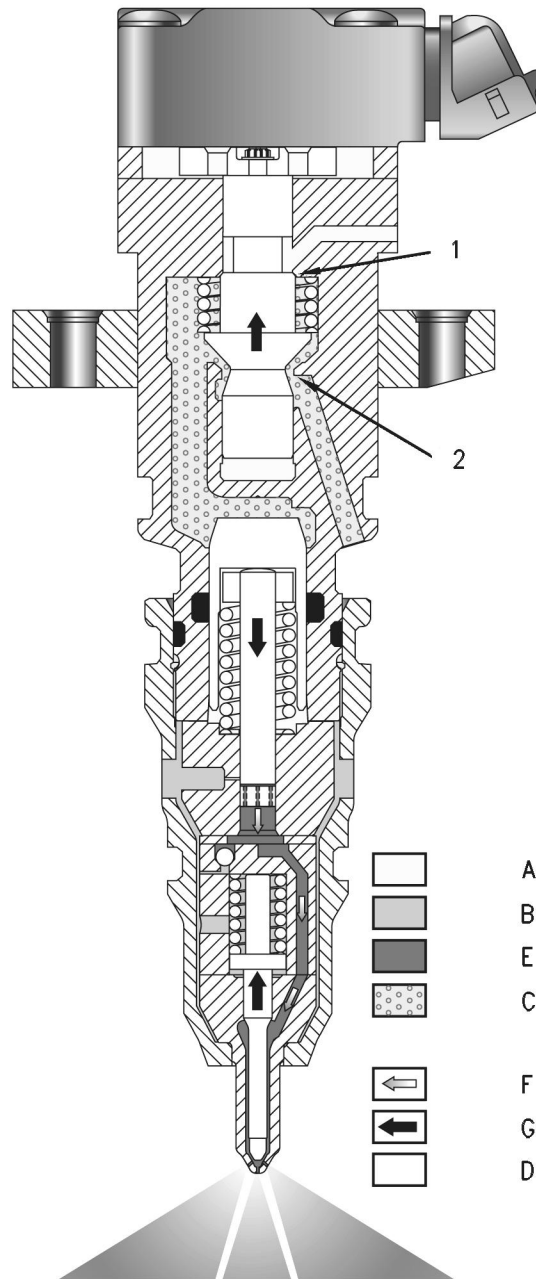

Illustration 16

g00295364

HEUI injector (Main Injection)

(1) Upper poppet seat (closed position)  
(2) Lower poppet seat (open position)  
(A) Drain (atmosphere)

(B) Fuel supply pressure  
(C) Actuation oil pressure  
(D) Moving parts

(E) Injection pressure  
(F) Fuel flow  
(G) Mechanical movement



While the solenoid is energized, the poppet valve remains open. While the poppet valve is open, high pressure oil continues to flow. The flow of the high pressure oil pushes downward on the intensifier piston and the plunger. The injection pressure fluctuates between 34 MPa (5000 psi) and 162 MPa (23500 psi). The injection pressure depends on the engine's requirements. Injection continues until either the solenoid is de-energized or the intensifier piston hits the bottom of the bore. When the solenoid is de-energized, the poppet spring is allowed to close the poppet valve. When the poppet valve closes, high pressure oil is shut off.

## End of Injection

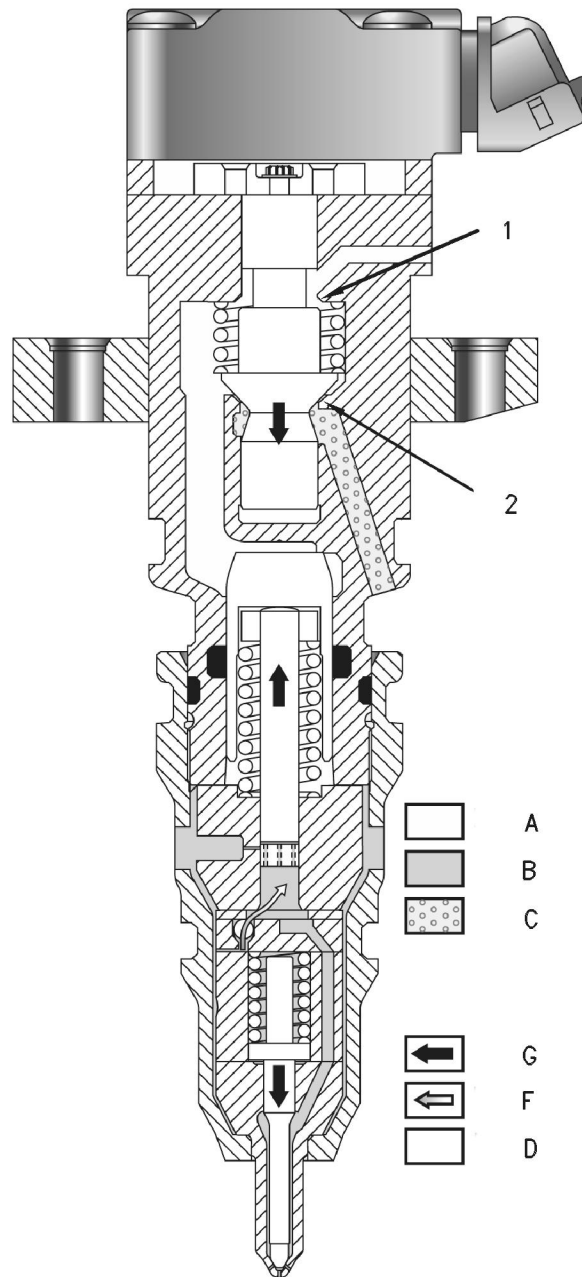

Illustration 17

g00295365

HEUI injector (End of Injection)

- (1) Upper poppet seat (open position)
- (2) Lower poppet seat (closed position)
- (A) Drain (atmosphere)
- (B) Fuel supply pressure

- (C) Actuation oil pressure
- (D) Moving parts
- (F) Fuel flow
- (G) Mechanical movement

The end of the injection cycle begins when the ECM stops the current to the unit injector solenoid. The magnetic field of the solenoid breaks down and the magnetic field is unable to overcome the spring force of the poppet. The poppet returns to the lower poppet seat which closes the poppet valve. When the poppet valve closes, high pressure oil is stopped from entering the unit injector. As the lower poppet seat closes, the upper poppet seat opens to the drain. When the upper poppet seat opens to the drain, the actuation pressure of the oil drops off.

Fuel injection pressure under the plunger exerts an upward force on the plunger and the intensifier piston. As the pressure of the actuation oil above the intensifier piston drops off, the downward force on the intensifier piston drops off. The upward force of the fuel injection pressure under the plunger suddenly becomes greater than the downward force on the intensifier piston. The downward motion of the intensifier piston and the plunger stops.

The exhaust oil on top of the intensifier piston can flow to the drain through the open upper poppet seat. Then, the oil flows through a vent hole to the rocker arm compartment under the valve cover.

When the downward travel of the plunger stops, fuel flow also stops. While the check is still open, the remaining fuel pressure pushes a small amount of fuel out of the orifice holes. This causes a large pressure drop which lowers injection pressure below Valve Closing Pressure (VCP). Spring tension on the check now reseats the check into the tip and injection stops.

When the check closes, injection stops. When injection stops, the fill cycle starts. The area above the intensifier piston cavity is open to atmospheric pressure through the upper poppet seat. Pressure drops very rapidly in the cavity above the intensifier piston to near zero. The return spring of the plunger pushes up on the plunger and the intensifier piston. As the plunger and the intensifier piston move upward, oil is forced around the upper poppet seat. After the oil is forced around the upper poppet seat, the oil is forced out of a vent hole.

As the plunger rises, pressure in the plunger cavity also drops to near zero. The fuel supply pressure is 450 kPa (65 psi). Fuel supply pressure unseats the plunger fill check in order to fill the plunger cavity with fuel. When the intensifier piston is pushed to the top of the bore, the fill cycle ends. When the fill cycle ends, the plunger cavity is full and the inlet fill check ball is reseated. Pressure above the intensifier piston and the poppet chamber is zero. The fuel injection cycle is complete and the unit injector is ready to begin again. The unit injector is now back in the pre-injection cycle.

## Fuel Heater And Water Separator (If Equipped)

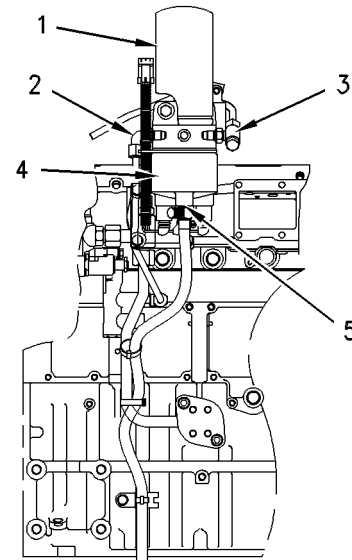

Illustration 18

g00291751

- (1) Fuel filter
- (2) Fuel inlet
- (3) Fuel outlet
- (4) Fuel heater and water separator
- (5) Drain valve

Some engines may have a combination of a fuel heater and a water separator. The fuel heater is controlled by a thermostat that is located in the base of the unit. The thermostat is preset. When the fuel temperature is below 4°C (40°F), the thermostat will turn on the heater. When the fuel temperature is 15°C (60°F), the thermostat will turn off the heater.

Water that has been separated from the fuel can be drained from the unit by lifting up on drain valve (5).

i02275840

## Air Inlet and Exhaust System

SMCS Code: 1050

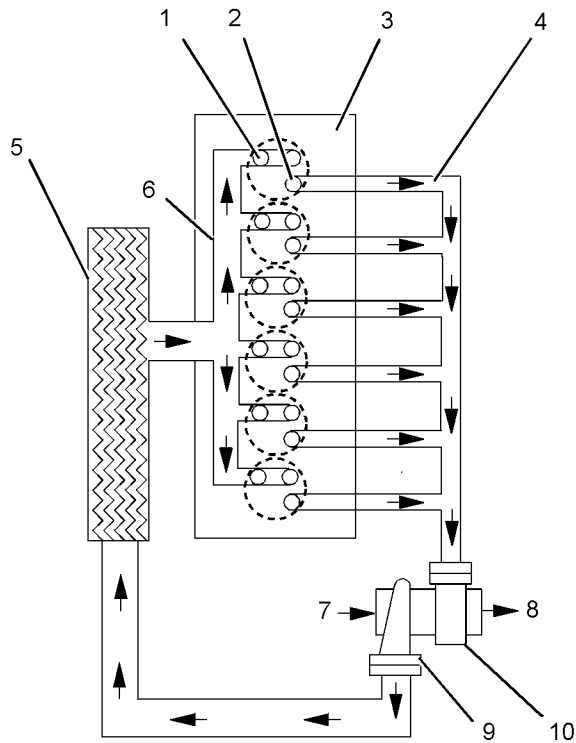

Illustration 19

g01139723

- (1) Inlet valve
- (2) Exhaust valve
- (3) Cylinder head
- (4) Exhaust manifold
- (5) Aftercooler core
- (6) Inlet manifold
- (7) Air inlet
- (8) Exhaust outlet
- (9) Compressor side of the turbocharger
- (10) Turbine side of the turbocharger

The components of the air inlet and exhaust system control the quality of the air that is available for combustion. These components also control the amount of the air that is available for combustion. The components of the air inlet and exhaust system are listed below:

- Air cleaner
- Turbocharger
- Aftercooler
- Cylinder head
- Valves and valve system components
- Piston and cylinder

- Exhaust manifold

Inlet air is pulled through the air cleaner. The inlet air is then compressed and heated by the compressor wheel of turbocharger (9) to about 150 °C (300 °F). The inlet air is then pushed through air-to-air aftercooler core (5) and the inlet air is moved to inlet manifold (6). The temperature of the inlet air upon entering inlet manifold (6) is about 43 °C (110 °F). Cooling of the inlet air increases the combustion efficiency. Increased combustion efficiency helps to lower fuel consumption. Also, increased combustion efficiency helps to increase horsepower output.

Aftercooler core (5) is a separate cooler core. Aftercooler core (5) is installed in front of the core (standard) of the engine radiator on the machine. Air that is ambient temperature is moved across the aftercooler core by the engine fan. This cools the turbocharged inlet air.

From aftercooler core (5), the air is forced into the cylinder head in order to fill the inlet ports. Air flow from the inlet port into the cylinder is controlled by inlet valves (1).

There are two inlet valves (1) and one exhaust valve (2) for each cylinder. Inlet valves open when the piston moves down on the inlet stroke. When the inlet valves open, cooled compressed air from the inlet port is pulled into the cylinder. The inlet valves close and the piston begins to move up on the compression stroke. The air in the cylinder is compressed. When the piston is near the top of the compression stroke, fuel is injected into the cylinder. The fuel mixes with the air and combustion starts. During the power stroke, the combustion force pushes the piston downward. After the power stroke is complete, the piston moves upward. This upward movement is the exhaust stroke. During the exhaust stroke, the exhaust valve opens, and the exhaust gases are pushed through the exhaust port into the exhaust manifold. After the piston completes the exhaust stroke, the exhaust valve closes and the cycle starts again. The complete cycle consists of four stages:

- Inlet stroke
- Compression stroke
- Power stroke
- Exhaust stroke

Exhaust gases from exhaust manifold (4) enter the turbine side of turbocharger (10) in order to turn the turbine wheel. The turbine wheel is connected to a shaft which drives the compressor wheel. Exhaust gases from the turbocharger pass through the exhaust outlet pipe, the muffler and the exhaust stack.

## Turbocharger

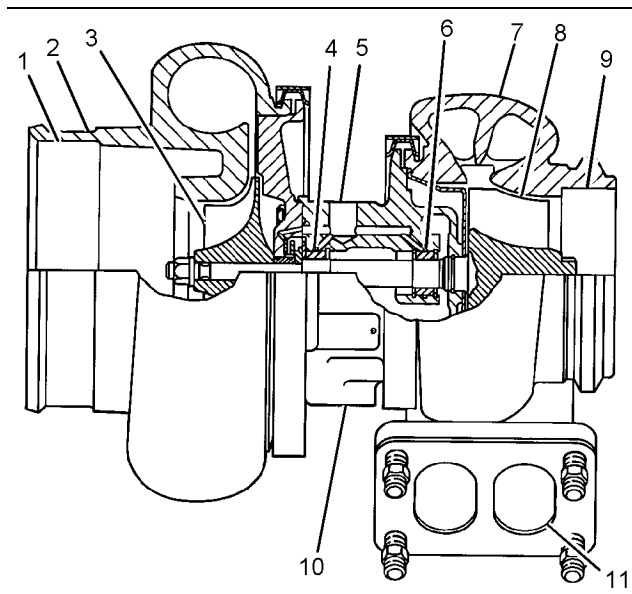

Illustration 20

g01096602

### Turbocharger

- (1) Air inlet
- (2) Compressor housing
- (3) Compressor wheel
- (4) Bearing
- (5) Oil Inlet port
- (6) Bearing
- (7) Turbine housing
- (8) Turbine wheel
- (9) Exhaust outlet
- (10) Oil outlet port
- (11) Exhaust inlet

The turbocharger is installed on the center section of the exhaust manifold. All the exhaust gases from the engine go through the turbocharger. The compressor side of the turbocharger is connected to the aftercooler by a pipe.

The exhaust gases go into turbine housing (7) through exhaust inlet (11). The exhaust gases then push the blades of turbine wheel (8). The turbine wheel is connected by a shaft to compressor wheel (3).

Clean air from the air cleaners is pulled through compressor housing air inlet (1) by the rotation of compressor wheel (3). The action of the compressor wheel blades causes a compression of the inlet air. This compression gives the engine more power by allowing the engine to burn more air and more fuel during combustion.

When the load on the engine increases, more fuel is injected into the cylinders. The combustion of this additional fuel produces more exhaust gases. The additional exhaust gases cause the turbine and the compressor wheels of the turbocharger to turn faster. As the compressor wheel turns faster, more air is forced into the cylinders. The increased flow of air gives the engine more power by allowing the engine to burn the additional fuel with greater efficiency.

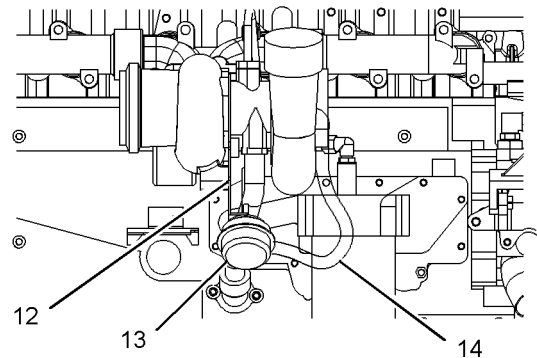

Illustration 21

g01139792

### Turbocharger With Wastegate

- (12) Actuating lever
- (13) Canister
- (14) Line (boost pressure)

When the engine is operating under conditions of low boost, a spring pushes on a diaphragm in canister (13). This action moves actuating lever (12) in order to close the valve of the wastegate. Closing the valve of the wastegate allows the turbocharger to operate at maximum performance.

As the boost pressure through line (14) increases against the diaphragm in canister (13), the valve of the wastegate is opened. When the valve of the wastegate is opened, the rpm of the turbocharger is limited by bypassing a portion of the exhaust gases. The exhaust gases are routed through the wastegate which bypasses the turbine wheel of the turbocharger.

**Note:** The turbocharger with a wastegate is preset at the factory and no adjustment can be made.

Bearings (4) and (6) for the turbocharger use engine oil under pressure for lubrication. The oil comes in through oil inlet port (5). The oil then goes through passages in the center section in order to lubricate the bearings. Oil from the turbocharger goes out through oil outlet port (10) in the bottom of the center section. The oil then goes back to the engine lubrication system.

## Valve System Components

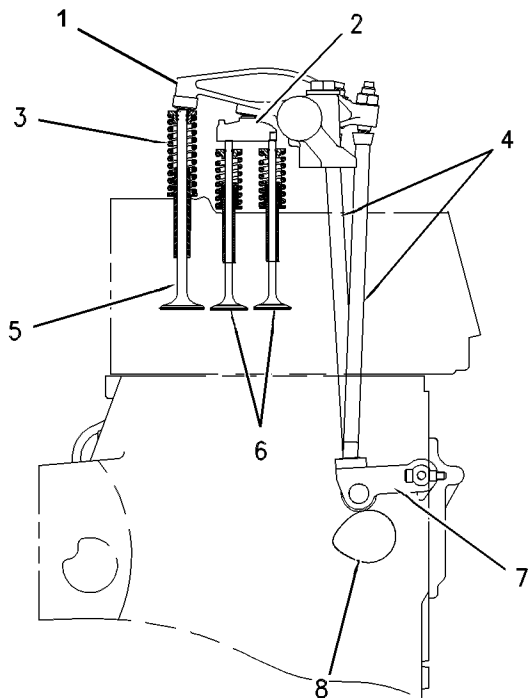

Illustration 22

g01107026

### Valve system components

- (1) Rocker arms
- (2) Bridge
- (3) Spring
- (4) Pushrods
- (5) Exhaust valve
- (6) Inlet valves
- (7) Lifter
- (8) Camshaft lobe

The valve system components control the flow of inlet air into the cylinders during engine operation. The valve system components also control the flow of exhaust gases out of the cylinders during engine operation.

The crankshaft gear drives the camshaft gear through an idler gear. The camshaft must be timed to the crankshaft in order to get the correct relation between the piston movement and the valve movement.

The camshaft has two camshaft lobes for each cylinder. The lobes operate the inlet and exhaust valves. As the camshaft turns, lobes on the camshaft cause lifters (7) to move pushrods (4) up and down. Upward movement of the pushrods against rocker arms (1) results in downward movement (opening) of valves (5) and (6).

Each cylinder has two inlet valves and one exhaust valve. Valve springs (3) close the valves when the lifters move down.

## Air Inlet Heater

The engines are equipped with an electric heater that is located behind the air inlet elbow. The electric heater has two functions:

- Aid in starting
- Aid in white smoke cleanup during start-up

Under the proper conditions, the Electronic Control Module (ECM) turns on the electric heater. The following conditions are evaluated prior to activating the electric heater:

- Jacket water coolant temperature
- Inlet manifold air temperature
- Ignition switch position
- Duration of time

The system is capable of delivering heat for 30 seconds prior to start-up and during cranking of the engine. After the engine has started, the system is capable of delivering heat constantly for 7 minutes, or the system can cycle the heat for 13 minutes. During the heating cycle, the heat is on for ten seconds and the heat is off for ten seconds.

If the air inlet heater malfunctions, the engine will still start and the engine will still run. There may be a concern regarding the amount of white smoke that is present. Also, there may be a concern regarding the need for an alternative starting aid.

## System Components

The system of the air inlet heater consists of the following basic components:

- Relay of the air inlet heater
- Heater element
- Coolant temperature sensor
- Inlet air temperature sensor
- ECM
- Indicator lamp

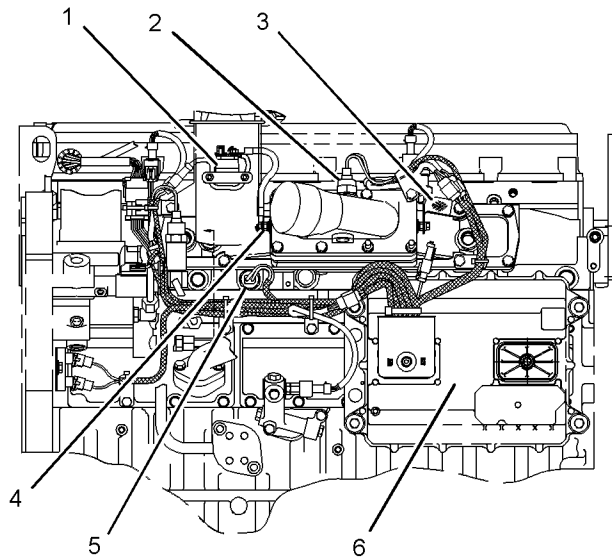

Illustration 23

g01139807

## Location Of Components

- (1) Relay of the air inlet heater
- (2) Inlet air temperature sensor
- (3) Ground strap (heater to engine)
- (4) Air inlet heater
- (5) Coolant temperature sensor
- (6) ECM

The relay for the air inlet heater (1) is located on the mounting bracket for the fuel filter. The relay turns the 12 V heater ON and OFF in response to signals from the ECM (6).

The air inlet heater (4) is a component of the air inlet cover. The heater element has a ground strap (3) that must be connected to the engine.

There are three conditions that would cause the air inlet heater to be activated:

- Powerup and Mode of Preheat

Regardless of temperature, the heater and the lamp of the heater should come on for two seconds when the ECM is first powered (lamp check). When the sum of the coolant temperature plus the inlet manifold air temperature is less than 25 °C (109 °F), the ECM will turn on the heater and the lamp for 30 seconds. This is a cycle of preheat.

The ECM will then turn off the heater and the lamp. When the operator attempts to start the engine prior to the completion of preheat, the ECM proceeds into the mode of cranking for heater control.

- Mode of cranking

During engine cranking, when the sum of the coolant temperature plus the inlet manifold air temperature is less than 25 °C (109 °F), the ECM will turn on the heater. The heater will remain on during engine cranking. If the engine fails to start, the ECM reverts to preheat. Reverting to preheat will activate the heater for another 30 seconds.

- Running of the engine

After the engine has started, the same combination of inlet manifold air temperature and coolant temperature will determine the state of the heater. The cycle has two strategies.

The two strategies are continuous and intermittent. During the continuous strategy, the heater will remain on for a maximum of 7 minutes after starting. If the same conditions exist, the ECM will activate the intermittent strategy. During the intermittent strategy, the heater is cycled for a maximum of 13 minutes. During this cycle, the heater is turned on for 10 seconds and the heater is turned off for 10 seconds. After the 13 minute time limit, the heater is shut off.

When one of the temperature sensors fails, the system will operate in the following manner:

- Coolant temperature sensor

When the coolant temperature sensor has an open circuit or a short circuit, the coolant temperature sensor has failed. During this condition, the heater will be activated when the inlet manifold air temperature is less than 10 °C (50 °F).

- Inlet air temperature sensor

When the inlet air temperature sensor has an open circuit or a short circuit, the inlet air temperature sensor has failed. During this condition, the heater will be activated when the coolant temperature is less than 40 °C (104 °F).

Under the proper condition, the heater will be reactivated. When the sum of the coolant temperature and the inlet manifold air temperature has dropped below 25 °C (109 °F), the heater will be reactivated. This condition could exist after a warm engine has cooled and the operator attempts to start the engine.

When the sum of the coolant temperature and the inlet manifold air temperature does not attain 35 °C (127 °F), the heater will be activated. The heater can be activated no longer than 20 minutes (maximum). The ECM will turn off the heater after the 20 minute time limit.

For additional information on the air inlet heater, refer to the Troubleshooting guide.

i01486056

# Lubrication System

SMCS Code: 1300

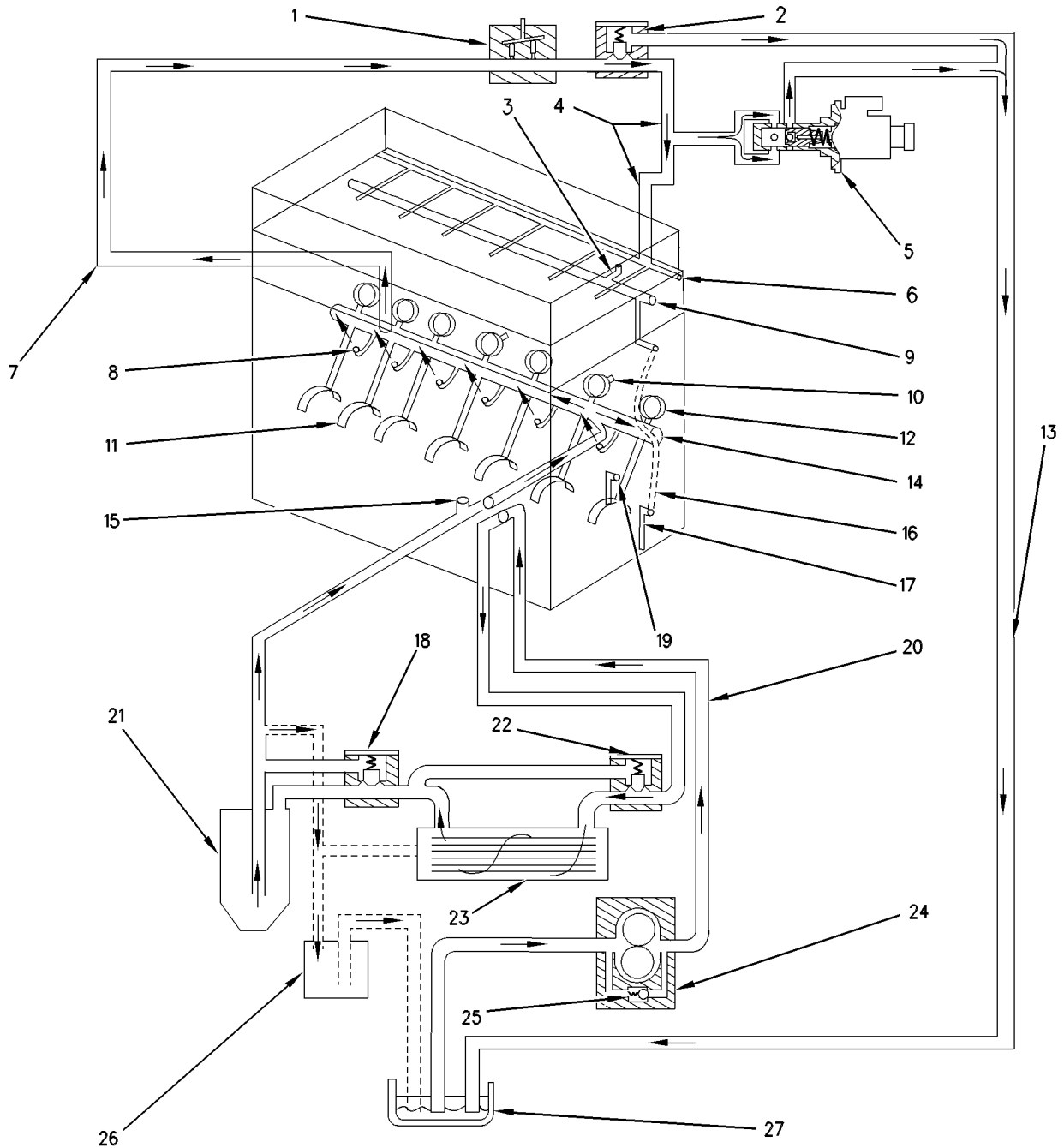

Illustration 24

g00292659

## Lubrication System Schematic

(1) Hydraulic pump. (2) High pressure relief valve. (3) Passage to the rocker arms. (4) High pressure oil line. (5) Injection actuation pressure control valve. (6) High pressure oil manifold. (7) Oil supply line for hydraulic pump. (8) Piston cooling jets. (9) Cylinder head gallery. (10) Passage to pushrod lifters. (11) Main bearings. (12) Camshaft bearing. (13) Passage to engine oil pan. (14) Main oil gallery. (15) Turbocharger oil supply line. (16) Passage to front housing. (17) Passage to oil pump idler gear bearing. (18) Oil filter bypass valve. (19) Passage to camshaft idler gear bearing. (20) Passage. (21) Engine oil filter. (22) Oil cooler bypass valve. (23) Engine oil cooler. (24) Engine oil pump. (25) Oil pump bypass valve. (26) Auxiliary engine oil filter (if equipped). (27) Engine oil pan.



Engine oil pump (24) is mounted to the bottom of the cylinder block inside the engine oil pan (27). The engine oil pump (24) pulls oil from engine oil pan (27). The engine oil pump pushes the oil through the passage to the engine oil cooler (23). Oil then flows through engine oil filter (21). The filtered oil then enters the turbocharger oil supply line (15) and main oil gallery (14).

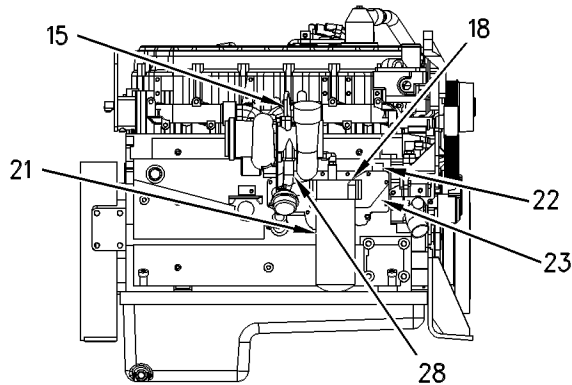

Illustration 25

g00292660

## Right Side View Of Engine

(15) Turbocharger oil supply line. (18) Oil filter bypass valve. (21) Engine oil filter. (22) Oil cooler bypass valve. (23) Oil cooler. (28) Turbocharger oil return tube.

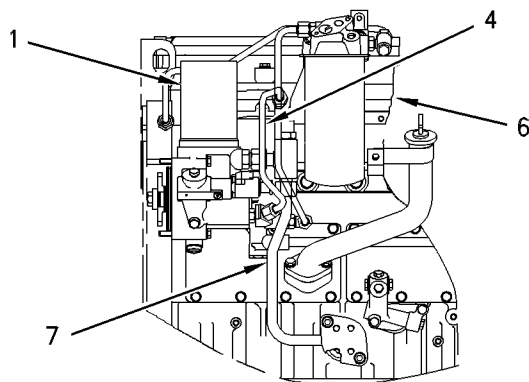

Illustration 26

g00292662

## Left Side View Of Engine

(1) Hydraulic pump. (4) Oil supply line (high pressure). (6) Oil manifold (high pressure). (7) Oil supply line (hydraulic pump).

The main oil gallery (14) distributes oil to main bearings (11), piston cooling jets (8), and camshaft bearing (12). Oil from main oil gallery (14) exits the front of the block. The oil then enters a groove that is cast in front housing (16).

Oil enters the crankshaft through holes in the bearing surfaces (journals) for the main bearing (11). Passages connect the bearing surface (journal) for the main bearing (11) with the bearing surface (journal) for the connecting rod.

The passage in front housing (16) sends the oil flow in two directions. At the upper end of the passage, oil is directed back into the block and up to cylinder head gallery (9) through passage (3) to the rocker arm mechanism. A passage (17) sends oil to the oil pump idler gear bearing.

Oil from the front main bearing enters a passage (19) to the camshaft idler gear bearing. Oil passages in the crankshaft send oil from all the main bearings (11) through the connecting rods to the connecting rod bearings.

The passages send oil from the camshaft bearing (12) to an oil passage in the side covers. The oil then enters a hole in the shafts to pushrod lifters (10). The oil lubricates the bearings of the lifter.

**Note:** Engines that are equipped with an auxiliary oil filter (26) will receive oil at a port. The filtered oil will be returned to engine oil pan (27).

The hydraulic pump (1) is a gear-driven axial piston pump. The hydraulic pump raises the engine oil pressure from the typical operating oil pressure to the actuation pressure that is required by the unit injectors. The injection actuation pressure control valve (5) electronically controls the output pressure of the hydraulic pump (1).

The oil circuit consists of a low pressure circuit and a high pressure circuit. The low pressure circuit typically operates at a pressure of 240 kPa (35 psi) to 480 kPa (70 psi). The low pressure circuit provides engine oil that has been filtered to the hydraulic pump (1). Also, the low pressure circuit provides engine oil that has been filtered to the lubricating system of the engine. Oil is drawn from the engine oil pan (27). Oil is supplied through the engine oil cooler (23) and engine oil filter (21) to both the engine and the hydraulic pump (1).

The high pressure oil system provides actuation oil to the unit injector. The high pressure circuit operates in a pressure range typically between 4 MPa (581 psi) and 23 MPa (3350 psi). This high pressure oil flows through a line into the cylinder head. The cylinder head stores the oil at actuation pressure. The oil is ready to actuate the unit injector. Oil is discharged from the unit injector under the valve cover so that no return lines are required.

After the lubrication oil's work is done, the lubrication oil returns to the engine oil pan.

The oil pump bypass valve (25) limits the pressure of the oil that is coming from the engine oil pump (24). The engine oil pump (24) can pump more than enough oil into the system. When there is more than enough oil, the oil pressure increases. When the oil pressure increases, the oil pump bypass valve (25) will open. This allows the oil that is not needed to go back to the suction side of the engine oil pump (24).

The bypass valves (22) and (18) will open when the engine is cold (starting conditions). Opening the bypass valves achieves immediate lubrication of all components. Immediate lubrication is critical when cold oil with high viscosity causes a restriction to the oil flow through engine oil cooler (23) and engine oil filter (21). The engine oil pump (24) sends the cold oil through the bypass valves around the engine oil cooler (23) and engine oil filter (21) to the turbocharger oil supply line (15) and the main oil gallery (14) in the cylinder block.

When the oil gets warm, the pressure difference in the bypass valves decreases and the bypass valves close. After the bypass valves close, there is a normal flow of oil through the engine oil cooler and the engine oil filter.

The bypass valves will also open when there is a restriction in the engine oil cooler (23) or engine oil filter (21). This design allows the engine to be lubricated even though engine oil cooler (23) or engine oil filter (21) are restricted.

The engine oil cooler bypass valve is also activated by pressure. If the oil pressure differential across the engine oil cooler reaches  $125 \pm 30$  kPa ( $18 \pm 4.5$  psi), the valve will open. Opening the valve allows the oil flow to bypass the engine oil cooler (23).

The main oil flow now reaches the main engine oil filter (21). When the oil pressure differential across the oil filter bypass valve (18) reaches  $125 \pm 30$  kPa ( $18 \pm 4.5$  psi), the valve opens in order to allow the oil flow to go around the oil filter (21). The oil flow continues in order to lubricate the engine components. When the oil is cold, an oil pressure difference in the bypass valve also causes the valve to open. This bypass valve then provides immediate lubrication to all the engine components when cold oil with high viscosity causes a restriction to the oil flow through the engine oil filter (21). The bypass valve will also open when there is a restriction in the engine oil filter (21). This design allows the engine to be lubricated even though engine oil filter (21) is restricted.

**Note:** Refer to Specifications, "Engine Oil Filter Base".

Filtered oil flows through the main oil gallery (14) in the cylinder block. Oil is supplied from the main oil gallery (14) to the following components:

- Piston cooling jets (8)
- Valve mechanism
- Camshaft bearing (12)
- Crankshaft main bearings

- Turbocharger cartridge

An oil cooling chamber is formed by the lip that is forged at the top of the skirt of the piston and the cavity that is behind the ring grooves in the crown. Oil flow for the piston cooling jet enters the cooling chamber through a drilled passage in the skirt. Oil flow from the piston cooling jet returns to the engine oil pan (27) through the clearance gap between the crown and the skirt. Four holes that are drilled from the piston oil ring groove to the interior of the piston drain excess oil from the oil ring.

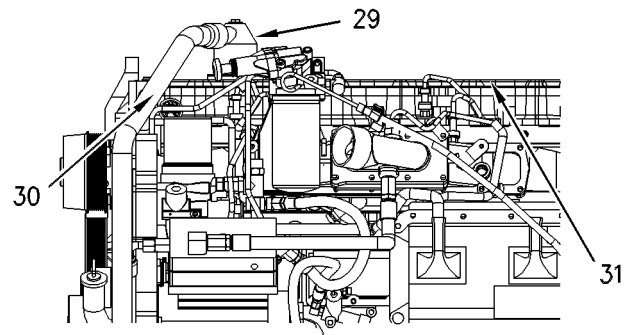

Illustration 27

g00292663

Front Left Side View Of Engine

(29) Breather. (30) Hose. (31) Valve cover.

Breather (29) allows engine blowby to escape from the crankcase. The engine blowby is discharged through hose (30) into the atmosphere. This prevents pressure from building up that could cause seals or gaskets to leak.

i02276477

## Cooling System

**SMCS Code:** 1350

This engine has a pressure type cooling system that is equipped with a shunt line.

A pressure type cooling system offers two advantages:

- The cooling system can operate safely at a temperature that is higher than the normal boiling point of water.
- The cooling system prevents cavitation in the water pump.

Cavitation is the sudden formation of low pressure bubbles in liquids by mechanical forces. The formation of air or steam pockets is more difficult within a pressure type cooling system.

The shunt line prevents cavitation by the water pump. The shunt line provides a constant flow of coolant to the water pump.

**Note:** In air-to-air aftercooled systems, a coolant mixture with a minimum of 30 percent ethylene glycol base antifreeze must be used for efficient water pump performance. This mixture keeps the cavitation temperature range of the coolant high enough for efficient performance. Refer to the Operation and Maintenance Manual for additional information on the coolant.

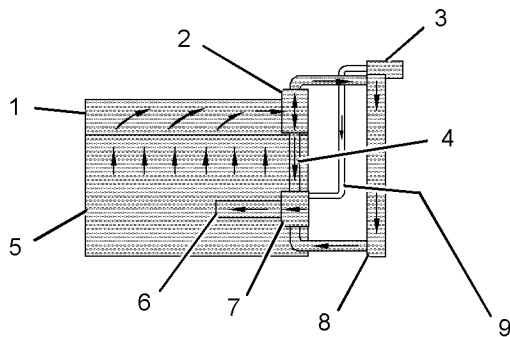

Illustration 28

g01103269

## Cooling System Schematic

- (1) Cylinder head
- (2) Water temperature regulator housing
- (3) Expansion tank
- (4) Bypass hose
- (5) Cylinder block
- (6) Oil cooler
- (7) Water pump
- (8) Radiator
- (9) Shunt line (expansion tank to water pump)

Water pump (7) is located on the right side of the cylinder block. The water pump is belt driven from the crankshaft pulley. Coolant can enter the water pump in three places:

- the inlet at the bottom of the water pump
- the bypass hose (4) into the top of the water pump
- the shunt line (9) into the top of the water pump

Coolant from the bottom of the radiator is pulled into the bottom inlet of the pump by impeller rotation. The coolant exits the back of the pump directly into the oil cooler cavity of the block.

All of the coolant passes through the core of the oil cooler and the coolant enters the internal water manifold of the cylinder block. The manifold disperses the coolant to water jackets around the cylinder walls.

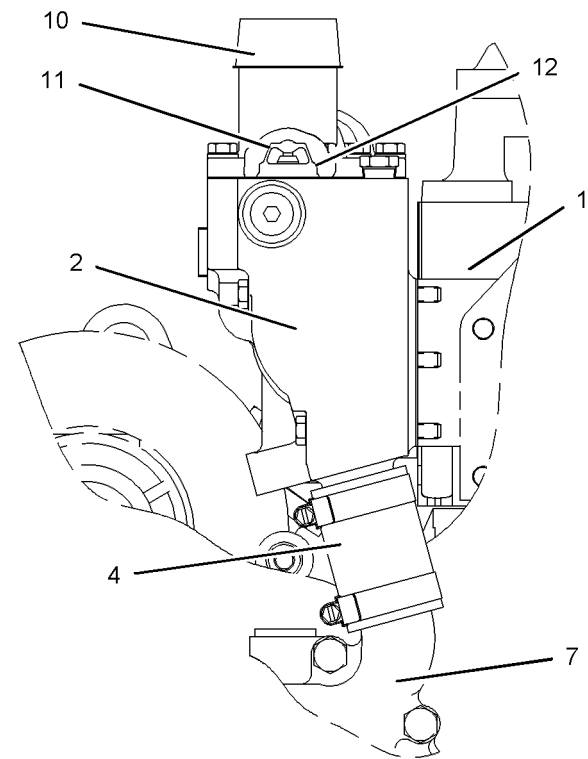

Illustration 29

g01139885

## Water lines group

- (1) Cylinder head
- (2) Water temperature regulator housing
- (4) Bypass hose
- (7) Water pump
- (10) Outlet to radiator
- (11) Water temperature regulator
- (12) Air vent valve in thermostat

From the cylinder block, the coolant flows into passages in the cylinder head. The passages send the flow around the unit injector sleeves and the inlet and the exhaust passages. The coolant now enters water temperature regulator housing (2) at the front right side of the cylinder head.

Water temperature regulator (11) controls the direction of flow. When the coolant temperature is below the normal operating temperature, the water temperature regulator is closed. The coolant is directed through bypass hose (4) and into the top inlet of the water pump. When the coolant temperature reaches the normal operating temperature, water temperature regulator (11) opens. When the water temperature regulator is open, the bypass is closed. Most of the coolant goes through outlet (10) to the radiator for cooling. The remainder flows through bypass hose (4) and into the water pump.

**Note:** Some coolant systems may contain two water temperature regulators.

The shunt line (9) extends from the top of the water pump to an expansion tank. The shunt line must be routed properly in order to avoid trapping any air. By providing a constant flow of coolant to the water pump, the shunt line keeps the water pump from cavitation.

**Note:** Water temperature regulator (11) is an important part of the cooling system. The water temperature regulator divides coolant flow between the radiator and the bypass in order to maintain the normal operating temperature. If the water temperature regulator is not installed in the system, there is no mechanical control, and most of the coolant will travel the path of least resistance through the bypass. This will cause the engine to overheat in hot weather and the engine will not reach normal operating temperature in cold weather.

**Note:** Air vent valve (12) will allow the air to escape past the water temperature regulator from the cooling system while the radiator is being filled. During normal operation, the air vent valve will be closed in order to prevent coolant flow past the water temperature regulator.

## Coolant For Air Compressor (If Equipped)

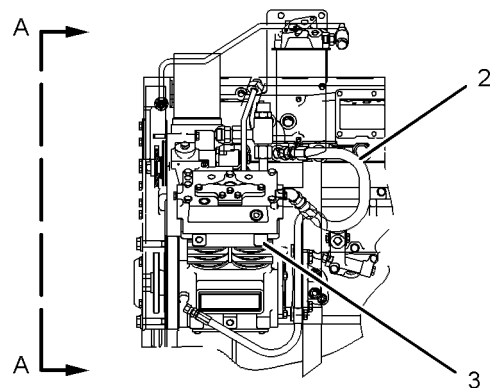
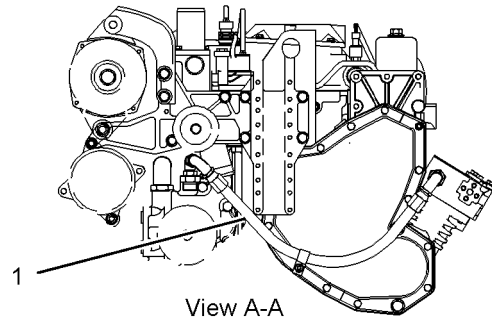

Illustration 30

g01139902

Coolant lines for air compressor

- (1) Coolant supply line
- (2) Coolant return line
- (3) Air compressor

If the engine is equipped with an air compressor, coolant is supplied from the water temperature regulator housing to air compressor (3) through coolant supply line (1). The coolant is circulated through the air compressor and the coolant is returned to the cooling system through coolant return line (2) into the cylinder head.

## Coolant Conditioner (If Equipped)

Some conditions of operation can cause pitting. This pitting is caused by corrosion or by cavitation erosion. A corrosion inhibitor is a chemical that provides a reduction in pitting. The addition of a corrosion inhibitor can keep this type of damage to a minimum.

The coolant conditioner element is a spin-on element that is similar to the fuel filter and to the oil filter elements. The coolant conditioner element attaches to the coolant conditioner base that is mounted on the front of the engine. Coolant flows from the water pump to the coolant conditioner base and back to the cylinder block. Coolant constantly flows through the coolant conditioner element when the valves are in the OPEN position.

The element has a specific amount of inhibitor for acceptable cooling system protection. As the coolant flows through the element, the corrosion inhibitor goes into the solution. The corrosion inhibitor is a dry solution, so the inhibitor dissolves. The corrosion inhibitor then mixes to the correct concentration. Two basic types of elements are used for the cooling system. The two elements are the precharge elements and the maintenance elements. Each type of element has a specific use. The elements must be used correctly in order to get the necessary concentration for cooling system protection. The elements also contain a filter. After the coolant conditioner is dissolved, the elements should remain in the system so that coolant will flow through the filters.

The precharge element contains more than the normal amount of inhibitor. The precharge element is used when a system is first filled with new coolant. This element must add enough inhibitor in order to bring the complete cooling system up to the correct concentration.

The maintenance elements have a normal amount of inhibitor. The maintenance elements are installed at the first change interval. A sufficient amount of inhibitor is provided by the maintenance elements in order to maintain the corrosion protection at an acceptable level. After the first change interval, only maintenance elements are installed. In order to provide the cooling system with protection, maintenance elements are installed at specific intervals.

i01388618

## Basic Engine

**SMCS Code:** 1200

### Cylinder Block And Head

The cylinder block has seven main bearings. The main bearing caps are fastened to the cylinder block with two bolts per cap.

Removal of the oil pan allows access to the crankshaft, the main bearing caps, the piston cooling jets, and the oil pump.

The camshaft is accessible through the covers on the left side of the cylinder block. These side covers support the pushrod lifters. The camshaft is supported by bearings that are pressed into the cylinder block. There are seven camshaft bearings.

The cylinder head is separated from the cylinder block by a nonasbestos fiber gasket with a steel backing. Coolant flows out of the cylinder block through gasket openings and into the cylinder head. This gasket also seals the oil supply and drain passages between the cylinder block and the cylinder head.

The air inlet ports are on the left side of the cylinder head, while the exhaust ports are located on the right side of the cylinder head. There are two inlet valves and one exhaust valve for each cylinder. Replaceable valve guides are pressed into the cylinder head. The hydraulically actuated electronically controlled unit injector is located between the three valves. Fuel is injected directly into the cylinders at very high pressure. A pushrod valve system controls the valves.

### Piston, Rings And Connecting Rods

One-piece aluminum pistons are used in most applications. Engines with higher cylinder pressures require two-piece pistons. Refer to the Parts Manual in order to obtain information about the type of pistons that are used in a specific engine.

#### One-Piece Pistons

The one-piece aluminum pistons have an iron band for the compression ring. This helps to reduce wear on the compression ring groove. The one-piece piston has three rings:

- Compression ring
- Intermediate ring
- Oil ring

All of the rings are located above the piston pin bore. The compression ring is a Keystone ring. Keystone rings have a tapered shape. The action of the ring in the piston groove that is tapered helps prevent seizure of the rings. Seizure of the rings is caused by deposits of carbon. The intermediate ring is rectangular with a sharp lower edge. The oil ring is a standard type of ring or a conventional type of ring. Oil returns to the crankcase through holes in the oil ring groove.

Oil from the piston cooling jets sprays the underside of the pistons. The spray lubricates the pistons and the spray cools the pistons. The spray also improves the piston's life and the spray also improves the ring's life.

The connecting rod has a taper on the pin bore end. This taper gives the connecting rod and the piston more strength. The additional strength is concentrated in the areas with the most load. Two bolts hold the connecting rod cap to the connecting rod. This design keeps the connecting rod width to a minimum, so that the connecting rod can be removed through the cylinder.

## Two-Piece Pistons

The two-piece articulated piston consists of an alloy forged steel crown that is connected to an aluminum skirt by the piston pin. The two-piece articulated piston has three rings:

- Compression ring
- Intermediate ring
- Oil ring

All of the rings are located above the piston pin bore. The compression ring is a Keystone ring. Keystone rings have a tapered shape. The action of the ring in the piston groove that is tapered helps prevent seizure of the rings. Seizure of the rings is caused by deposits of carbon. The intermediate ring is rectangular with a sharp lower edge. The oil ring is a standard type of ring or a conventional type of ring. Oil returns to the crankcase through holes in the oil ring groove.

Oil from the piston cooling jets sprays the underside of the pistons. The spray lubricates the pistons and the spray cools the pistons. The spray also improves the piston's life and the spray also improves the ring's life.

The connecting rod has a taper on the pin bore end. This taper gives the connecting rod and the piston more strength. The additional strength is concentrated in the areas with the most load. Two bolts hold the connecting rod cap to the connecting rod. This design keeps the connecting rod width to a minimum, so that the connecting rod can be removed through the cylinder.

## Crankshaft

The crankshaft changes the combustion forces in the cylinder into usable rotating torque which powers the equipment. A vibration damper is used at the front of the crankshaft to reduce torsional vibrations (twist on the crankshaft) that can cause damage to the engine.

The crankshaft drives a group of gears on the front of the engine. The gear group drives the following devices:

- Oil pump
- Camshaft
- Hydraulic oil pump
- Gear-driven air compressor
- Power steering pump

In addition, belt pulleys on the front of the crankshaft drive the following components:

- Radiator fan
- Water pump
- Alternator
- Refrigerant compressor

Hydrodynamic seals are used at both ends of the crankshaft to control oil leakage. The hydrodynamic grooves in the seal lip move lubrication oil back into the crankcase as the crankshaft turns. The front seal is located in the front housing. The rear seal is installed in the flywheel housing.

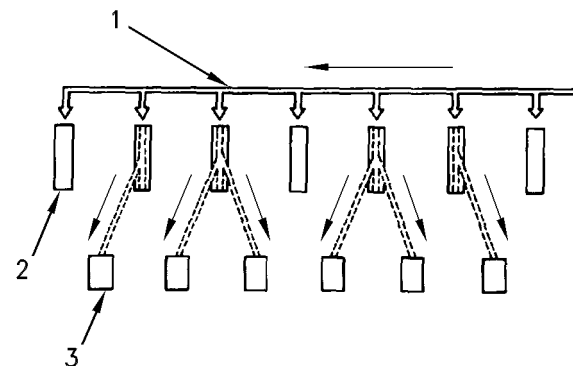

Illustration 31  
Schematic Of Oil Passages In Crankshaft  
(1) Oil gallery  
(2) Main bearings  
(3) Connecting rod bearings

g00293227

Pressure oil is supplied to all main bearings through drilled holes in the webs of the cylinder block. The oil then flows through drilled holes in the crankshaft in order to provide oil to the connecting rod bearings. The crankshaft is held in place by seven main bearings. A thrust bearing next to the rear main bearing controls the end play of the crankshaft.

## Vibration Damper

The force from combustion in the cylinders will cause the crankshaft to twist. This is called torsional vibration. If the vibration is too great, the crankshaft will be damaged. The vibration damper limits the torsional vibrations to an acceptable amount in order to prevent damage to the crankshaft.

### Rubber Vibration Damper (If Equipped)

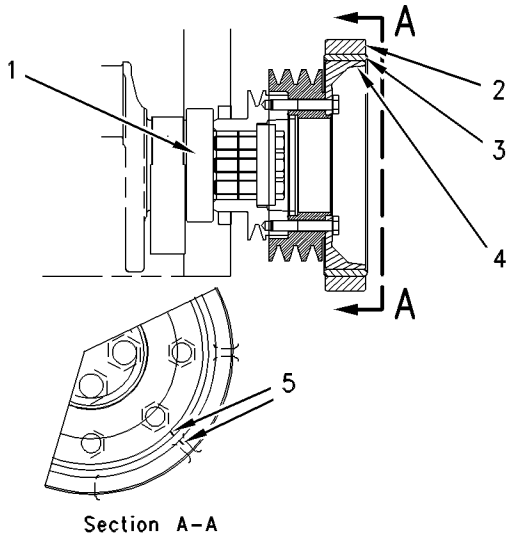

Illustration 32

g00293231

#### Rubber Vibration Damper

(1) Crankshaft. (2) Ring. (3) Rubber ring. (4) Hub. (5) Alignment marks.

The rubber vibration damper is installed on the front of crankshaft (1). The hub (4) and ring (2) are isolated by a rubber ring (3). The rubber vibration damper has alignment marks (5) on the hub and the ring. These marks give an indication of the condition of the rubber vibration damper.

### Viscous Vibration Damper (If Equipped)

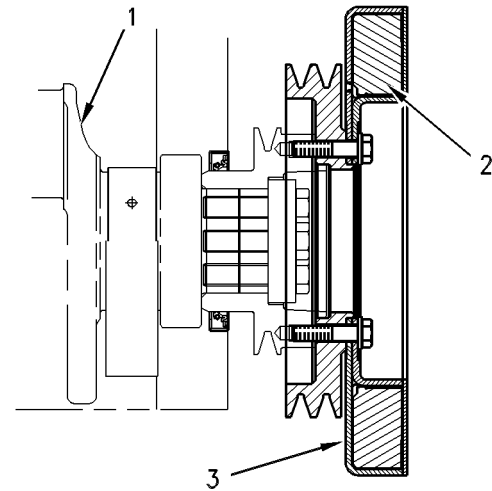

Illustration 33

g00293230

#### Cross Section Of Viscous Vibration Damper

(1) Crankshaft. (2) Weight. (3) Case.

The viscous vibration damper is installed on the front of crankshaft (1). The viscous vibration damper has a weight (2) in a case (3). The space between the weight and the case is filled with a viscous fluid. The weight moves in the case in order to limit the torsional vibration.

## Camshaft

The camshaft is located in the upper left side of the cylinder block. The camshaft is driven by gears at the front of the engine. Seven bearings support the camshaft. A thrust plate is mounted between the camshaft drive gear and a shoulder of the camshaft in order to control the end play of the camshaft.

The camshaft is driven by an idler gear which is driven by the crankshaft gear. The camshaft rotates in the same direction as the crankshaft. The crankshaft rotates in the counterclockwise direction when the engine is viewed from the flywheel end of the engine. There are timing marks on the crankshaft gear, the idler gear, and the camshaft gear in order to ensure the correct camshaft timing to the crankshaft for proper valve operation.

As the camshaft turns, each lobe moves a lifter assembly. There are two lifter assemblies for each cylinder. Each lifter assembly moves a pushrod. Each pushrod moves a valve (exhaust) or a set of valves (inlet). The camshaft must be in time with the crankshaft. The relation of the camshaft lobes to the crankshaft position causes the valves in each cylinder to operate at the correct time.

i01478239

## Electrical System

SMCS Code: 1400; 1550; 1900

### Grounding Practices

Proper grounding for the vehicle electrical system and the engine electrical systems is necessary for proper vehicle performance and reliability. Improper grounding will result in unreliable electrical circuit paths and uncontrolled electrical circuit paths.

Uncontrolled engine electrical circuit paths can result in damage to main bearings, crankshaft bearing journal surfaces, and aluminum components.

Uncontrolled electrical circuit paths can cause electrical noise which may degrade the vehicle and radio performance.

To ensure proper functioning of the vehicle and engine electrical systems, an engine-to-frame ground strap with a direct path to the battery must be used. This may be provided by a starting motor ground, by a frame to starting motor ground, or by a direct frame to engine ground. An engine-to-frame ground strap must be used in order to connect the grounding stud of the engine to the frame of the vehicle and to the negative battery post.

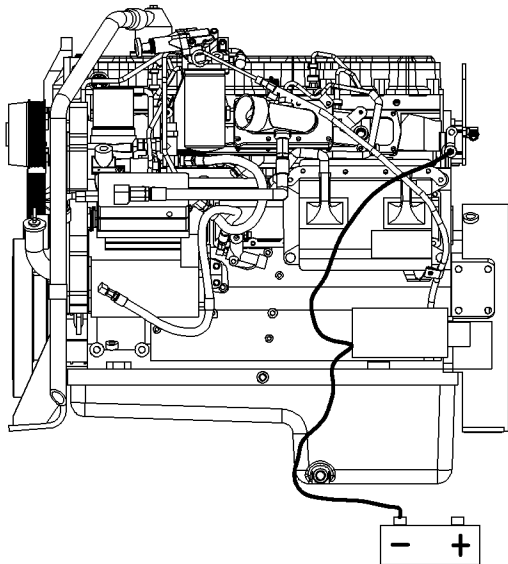

Illustration 34

g00769833

Grounding Stud To Battery Ground (“-”)

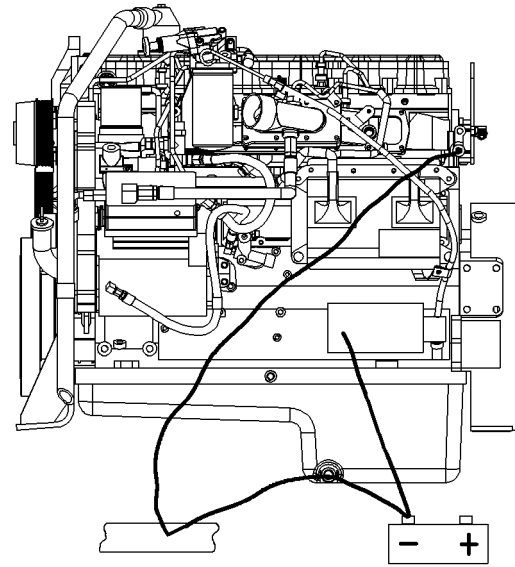

Illustration 35

g00769834

Alternate Grounding Stud To Battery Ground (“-”)

The engine must have a wire ground to the battery.

Ground wires or ground straps should be combined at ground studs that are only for ground use. The engine grounds should be inspected after every 20125 km (12,500 miles) or every 250 hours. All of the grounds should be tight and free of corrosion.

The engine alternator should be battery ground with a wire size that is capable of managing the full charging current of the alternator.

#### NOTICE

When boost starting an engine, the instructions in Systems Operation, “Engine Starting” should be followed in order to properly start the engine.

This engine may be equipped with a 12 volt starting system or a 24 volt starting system. Only equal voltage for boost starting should be used. The use of a higher voltage will damage the electrical system.

The Electronic Control Module (ECM) must be disconnected at the “J1/P1” and “J2/P2” locations before welding on the vehicle.

### Engine Electrical System

The electrical system has three separate circuits:

- Charging circuit
- Starting circuit
- Low amperage circuit



Some of the electrical system components are used in more than one circuit. The following components are used in each of the three circuits:

- Battery
- Circuit breaker
- Ammeter
- Battery cables

The charging circuit is in operation when the engine is running. An alternator generates electricity for the charging circuit. A voltage regulator in the circuit controls the electrical output in order to keep the battery at full charge.

---

#### NOTICE

The disconnect switch, if equipped, must be in the ON position in order to let the electrical system function. There will be damage to some of the charging circuit components if the engine is running with the disconnect switch in the OFF position.

---

If the vehicle has a disconnect switch, the starting circuit can operate only after the disconnect switch is put in the ON position.

The starting circuit is in operation only when the start switch is activated.

Both the low amperage circuit and the charging circuit are connected to the same side of the ammeter. The starting circuit is connected to the opposite side of the ammeter.

---

#### NOTICE

Never operate the alternator without the battery in the circuit. Making or breaking an alternator connection with heavy load on the circuit can cause damage to the regulator.

---

## Charging System Components

### Alternator

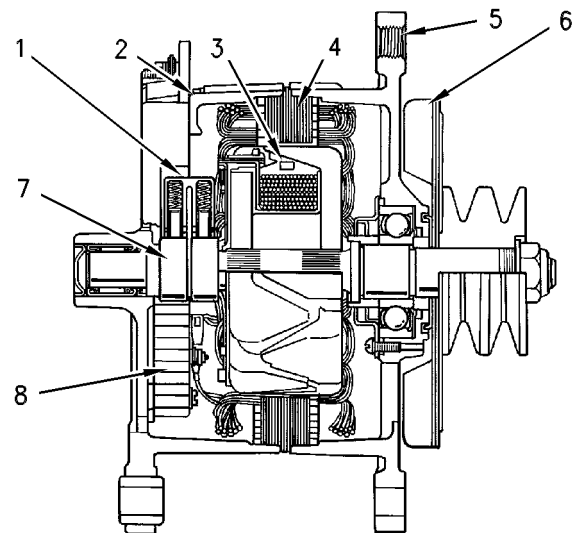

Illustration 36

g00293544

Alternator Components (Typical Example)

(1) Brush holder. (2) Rear frame. (3) Rotor. (4) Stator. (5) Drive end frame. (6) Fan assembly. (7) Slip rings. (8) Rectifier.

The alternator has three-phase, full-wave, rectified output. The alternator uses brushes to generate electricity.

The alternator is an electrical component and a mechanical component that is driven by a belt from engine rotation. The alternator is used to charge the storage battery during engine operation. The alternator is cooled by a fan that is a part of the alternator. The fan pulls air through holes in the back of the alternator. The air exits the front of the alternator and the air cools the alternator in the process.

The alternator converts mechanical energy and magnetic energy into alternating current (AC) and voltage. This process is done by rotating an electromagnetic field (rotor) that is direct current (DC) inside a three-phase stator. The alternating current and the voltage that is generated by the stator are changed to direct current. This change is accomplished by a system that uses three-phase, full-wave, rectified outputs. The three-phase, full-wave, rectified outputs have been converted by six rectifier diodes that are made of silicon. The alternator also has a diode trio. A diode trio is an assembly that is made up of three exciter diodes. The diode trio rectifies field current that is needed to start the charging process. Direct current flows to the alternator output terminal.

A solid-state regulator is installed in the back of the alternator. Two brushes conduct the current through two slip rings to the field coil on the rotor.

Also, a capacitor is mounted in the back of the alternator. The capacitor protects the rectifier from high voltages. The capacitor also suppresses radio noise sources.

The voltage regulator is a solid-state electronic switch that controls the alternator output. The voltage regulator limits the alternator voltage to a preset value by controlling the field current. The voltage regulator feels the voltage in the system. The voltage regulator switches ON and OFF many times per second in order to control the field current for the alternator. The alternator uses the field current in order to generate the required voltage output.

**Note:** Refer to Service Manual, SENR3862 for detailed service information for the Delco Remy 27 SI Series Alternator.

**Note:** If the alternator is connected to an engine component, the ground strap must connect that engine component to the frame or to the battery ground.

## Starting System Components

### Starting Solenoid

A solenoid is a magnetic switch that does two basic operations:

- The solenoid closes the high current starting motor circuit with a low current start switch circuit.
- The solenoid engages the starting motor pinion with the ring gear.

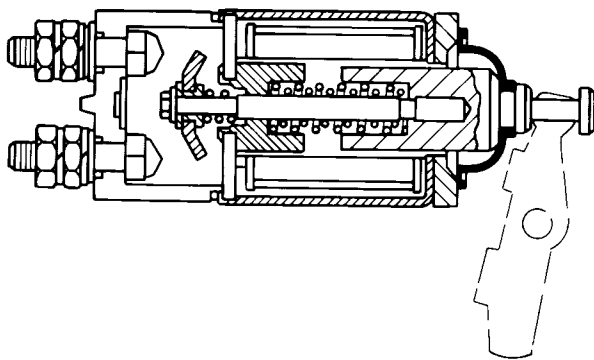

Illustration 37  
Typical Solenoid

g00285112

The solenoid has windings (one set or two sets) around a hollow cylinder. A plunger with a spring loaded device is inside of the cylinder. The plunger can move forward and backward. When the start switch is closed and electricity is sent through the windings, a magnetic field is created. The magnetic field pulls the plunger forward in the cylinder. This moves the shift lever in order to engage the pinion drive gear with the ring gear. The front end of the plunger then makes contact across the battery and the motor terminals of the solenoid. After the contact is made, the starting motor begins to turn the flywheel of the engine.

When the start switch is opened, current no longer flows through the windings. The spring now pushes the plunger back to the original position. At the same time, the spring moves the pinion gear away from the flywheel.

When two sets of solenoid windings are used, the windings are called the hold-in winding and the pull-in winding. Both sets of windings have the same number of turns around the cylinder, but the pull-in winding uses a wire with a larger diameter. The wire with a larger diameter produces a greater magnetic field. When the start switch is closed, part of the current flows from the battery through the hold-in windings. The rest of the current flows through the pull-in windings to the motor terminal. The current then flows through the motor to ground. The solenoid is fully activated when the connection across the battery and the motor terminal is complete. When the solenoid is fully activated, the current is shut off through the pull-in windings. At this point, only the smaller hold-in windings are in operation. The hold-in windings operate for the duration of time that is required in order to start the engine. The solenoid will now draw less current from the battery, and the heat that is generated by the solenoid will be kept at an acceptable level.

## Starting Motor

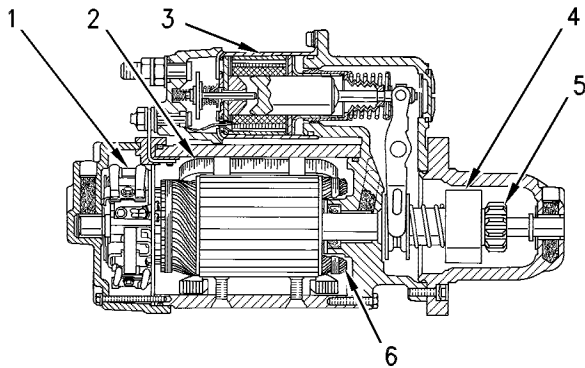

Illustration 38

g00293548

Starting Motor (Typical Example)

(1) Brush assembly. (2) Field windings. (3) Solenoid. (4) Clutch.  
(5) Pinion. (6) Armature.

The starting motor is used to turn the engine flywheel at a rate that will allow the engine to start running.

**Note:** Some starting motors have ground straps that connect the starting motor to the frame, but many of these starting motors are not grounded to the engine. These starting motors have electrical insulation systems. For this reason, the ground strap that connects the starting motor to the frame may not be an acceptable engine ground. Starting motors that were installed as original equipment are grounded to the engine. These starting motors have a ground wire from the starting motor to the negative terminal of the battery. When a starting motor must be changed, consult an authorized dealer for the proper grounding practices for that starting motor.

The starting motor has a solenoid. When the ignition switch is turned to the START position, the starting motor solenoid will be activated electrically. The solenoid plunger will now move a mechanical linkage. The mechanical linkage will push the starting motor pinion in order to engage with the flywheel ring gear. The starter motor pinion will engage with the ring gear before the electric contacts in the solenoid close the circuit between the battery and the starting motor. When the circuit between the battery and the starting motor is complete, the pinion will turn the engine flywheel. A clutch gives protection for the starting motor so that the engine cannot turn the starting motor too fast.

When the ignition switch is released from the START position, the starting motor solenoid is deactivated. The starting motor solenoid is deactivated when current no longer flows through the windings. The spring now pushes the plunger back to the original position of the plunger. At the same time, the spring moves the pinion gear away from the flywheel ring gear.

# Testing and Adjusting Section

## Fuel System

### Fuel System - Inspect

SMCS Code: 1250-040

#### Initial Inspection Of The Fuel System

A problem with the components that send fuel to the engine can cause low fuel pressure. This can decrease engine performance.

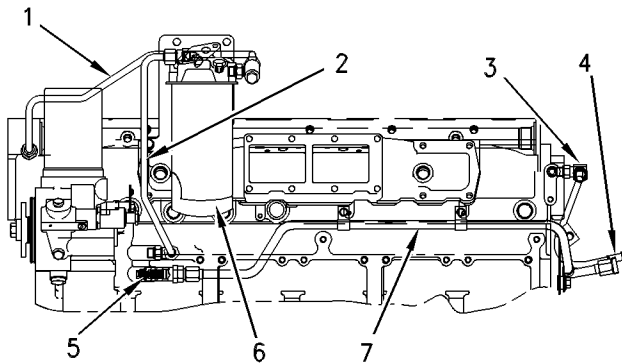

Illustration 39

g00296730

#### Fuel System

- (1) Tube assembly (fuel filter to fuel supply passage)
- (2) Tube assembly (fuel transfer pump to fuel filter)
- (3) Pressure regulator
- (4) Tube assembly (tank return line)
- (5) Fuel inlet port (fuel transfer pump)
- (6) Fuel filter
- (7) Tube assembly

1. Check the fuel level in the fuel tank. Inspect the cap for the fuel tank. Ensure that the vent in the fuel cap is not filled with dirt.
2. Check all fuel lines for fuel leakage. The fuel lines must be free from restrictions and faulty bends. Verify that the fuel return line is not collapsed.
3. Clean the screen inside the inlet fitting of the fuel transfer pump.

4. Operate the hand priming pump (if equipped). If excessive resistance is felt, inspect the fuel pressure regulating valve (3). Make sure that the pressure regulator (3) is installed correctly, and make sure that the pressure regulator functions correctly.
5. Install a new fuel filter (6).
6. Cut the old filter open with the 4C-5084 Oil Filter Cutter. Inspect the filter for excess contamination. Determine the source of the contamination. Make the necessary repairs.
7. Service the primary fuel filter (if equipped).
8. Operate the hand priming pump (if equipped). If uneven resistance is felt, test for air in the fuel. Refer to Testing and Adjusting, "Air in Fuel - Test" for more information.
9. Remove any air that may be in the fuel system. Refer to Testing and Adjusting, "Fuel System - Prime".

#### Start Up Procedure

**Note:** Refer to Operation and Maintenance Manual, "Engine Starting" in the Operation Section.

After work has been done on the fuel system, consider the following precautions before you start the engine. Make sure that you use this starting procedure to start the engine only after the fuel system has been worked on:

1. Disconnect the air inlet system from the turbocharger.

#### WARNING

**Be careful when placing the steel plate against the opening on the turbocharger air inlet. To avoid crushed fingers, do not position fingers between the steel plate and the opening on the turbocharger air inlet. Due to excessive suction, the plate can be forcefully pulled against the opening on the turbocharger air inlet.**

2. Another person will need to help as a precautionary step. This person should be ready to use the steel plate to cover the turbocharger air inlet if a problem occurs.

**Note:** Make sure that the steel plate is large enough to cover the entire turbocharger air inlet.

3. Start the engine.

Immediately place the steel plate against the opening on the turbocharger air inlet, if the engine operates in one of the following ways:

- The engine runs too fast.
- The engine runs out of control.

Covering the opening will stop the air supply to the engine, so the engine will stop.

## Inspection With The Engine Running

Either too much fuel for combustion or not enough fuel for combustion can be the cause of a problem in the fuel system. Finding the source of the problem can be difficult, especially when you have smoke that rises from the exhaust. Therefore, work is often done on the fuel system when the problem is really with some other part of the engine.

When noticeable smoke rises from the exhaust, this problem can be caused by a damaged unit injector. This unusual smoke can also be caused by one or more of the reasons that follow:

- not enough air for good combustion
- an overload at high altitude
- oil leakage into combustion chamber
- altitude
- air inlet and exhaust leaks

**Note:** Refer to Troubleshooting for more information on the fuel system.

## Checking The Operation Of Individual Cylinders

Low temperature at an exhaust manifold port is an indication of no fuel to the cylinder. This can possibly be an indication of an injector with a defect. An extra high temperature at an exhaust manifold port can be an indication of too much fuel to the cylinder. High temperatures may also be caused by an injector with a defect.

Refer to Testing And Adjusting, "Exhaust Temperature - Test" for the procedure for checking the temperatures in the exhaust manifold port.

i02486845

## Air in Fuel - Test

**SMCS Code:** 1280-081

This procedure checks for air in the fuel. This procedure also assists in finding the source of the air.

1. Examine the fuel system for leaks. Ensure that the fuel line fittings are properly tightened. Check the fuel level in the fuel tank. Air can enter the fuel system on the suction side between the fuel transfer pump and the fuel tank.
2. Install a 2P-8278 Tube As (SIGHT GAUGE) in the fuel return line. When possible, install the sight gauge in a straight section of the fuel line that is at least 304.8 mm (12 inches) long. Do not install the sight gauge near the following devices that create turbulence:
  - Elbows
  - Relief valves
  - Check valves

Observe the fuel flow during engine cranking. Look for air bubbles in the fuel. If there is no fuel in the sight gauge, prime the fuel system. Refer to Testing and Adjusting, "Fuel System - Prime" for more information. If the engine starts, check for air in the fuel at varying engine speeds. When possible, operate the engine under the conditions which have been suspect of air in the fuel.

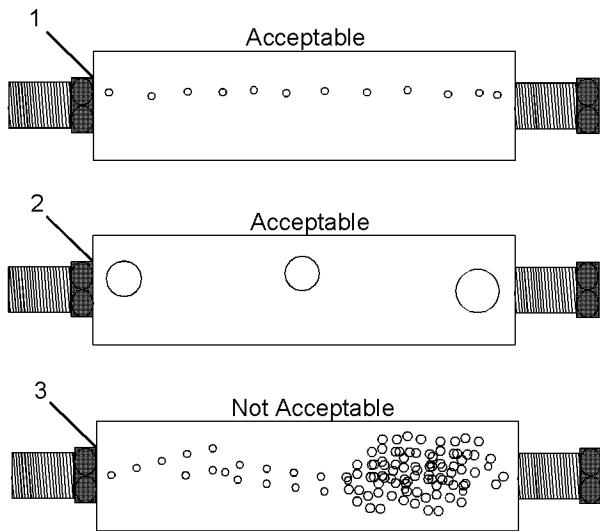

Illustration 40 g01096678

2P - 8278 Tube As (SIGHT GAUGE)

- (1) A steady stream of small bubbles with a diameter of approximately 1.60 mm (0.063 inch) is an acceptable amount of air in the fuel.
  - (2) Bubbles with a diameter of approximately 6.35 mm (0.250 inch) are also acceptable if there is two seconds to three seconds intervals between bubbles.
  - (3) Excessive air bubbles in the fuel are not acceptable.
3. If excessive air is seen in the sight gauge in the fuel return line, install a second sight gauge at the inlet to the fuel transfer pump. If a second sight gauge is not available, move the sight gauge from the fuel return line and install the sight gauge at the inlet to the fuel transfer pump. Observe the fuel flow during engine cranking. Look for air bubbles in the fuel. If the engine starts, check for air in the fuel at varying engine speeds.

If excessive air is not seen at the inlet to the fuel transfer pump, the air is entering the system after the fuel transfer pump. Proceed to Step 6.

If excessive air is seen at the inlet to the fuel transfer pump, air is entering through the suction side of the fuel system.

**WARNING**

To avoid personal injury, always wear eye and face protection when using pressurized air.

**NOTICE**

To avoid damage, do not use more than 55 kPa (8 psi) to pressurize the fuel tank.

4. Pressurize the fuel tank to 35 kPa (5 psi). Do not use more than 55 kPa (8 psi) in order to avoid damage to the fuel tank. Check for leaks in the fuel lines between the fuel tank and the fuel transfer pump. Repair any leaks that are found. Check the fuel pressure in order to ensure that the fuel transfer pump is operating properly. For information about checking the fuel pressure, see Testing and Adjusting, "Fuel System Pressure - Test".
5. If the source of the air is not found, disconnect the supply line from the fuel tank and connect an external fuel supply to the inlet of the fuel transfer pump. If this corrects the problem, repair the fuel tank or the stand pipe in the fuel tank.
6. If the injector sleeve is worn or damaged, combustion gases may be leaking into the fuel system. Also, if the O-rings on the injector sleeves are worn, missing, or damaged, combustion gases may leak into the fuel system.

i02276736

## Engine Speed - Check

**SMCS Code:** 1000

Table 1

Tools Needed		
Part Number	Part Name	Quantity
1U-6602 or 9U-7400	Photo-Tachometer <sup>(1)</sup> or Multitach Tool Gp	1

<sup>(1)</sup> This unit is a hand-held service tool.

**Note:** Caterpillar Electronic Technician (ET) can also be used.

You can observe the engine rpm, which is displayed on the status screen of Cat ET.

i02276920

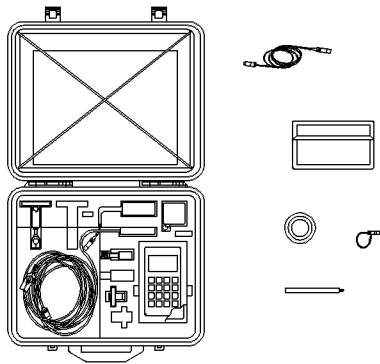

Illustration 41 g00286276  
9U-7400 Multitach Tool Gp

The 9U-7400 Multitach Tool Gp can measure engine rpm from a magnetic pickup. This magnetic pickup is located in the flywheel housing. The multitach also uses the ability to measure engine rpm from visual engine parts that are rotating.

**Note:** Refer to Special Instruction, NEHS0605 that is with the 9U-7400 Multitach Tool Gp. This manual gives instructions for the test procedure.

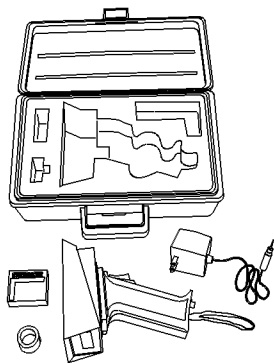

Illustration 42 g00296064  
1U-6602 Photo-Tachometer

The 1U-6602 Photo-Tachometer is a phototach for general use. This tachometer can only register the basic input frequency on any rotating part that is visible. The basic input frequency is 1 pulse per revolution per piece of reflective tape.

**Note:** Refer to Special Instruction, SEHS8854 that is with this group. This manual provides instructions for using this tool.

**Note:** The measurement of engine rpm can be set with the Cat ET. Refer to the Troubleshooting manual.

## Finding Top Center Position for No. 1 Piston

SMCS Code: 1105-531

Table 2

Required Tools			
Tool	Part Number	Description	Qty
A	136-4632	Timing Pin	1
B	139-7063	Timing Pin Adapter	1
C	5P-7305	Engine Turning Tool	1
D	9U-6943 or 9U-7336	Housing As	1
E	178-8615	Engine Turning Tool	1

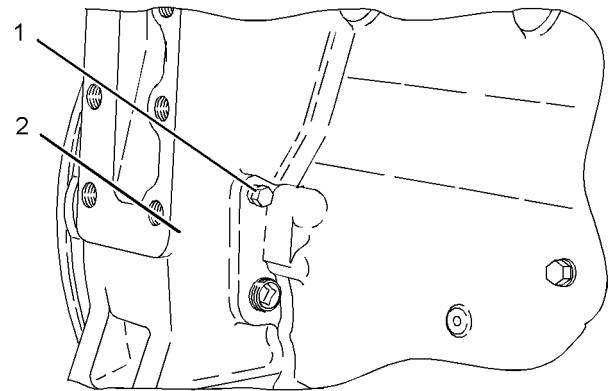

Illustration 43 g01140081  
Timing hole location (typical example)

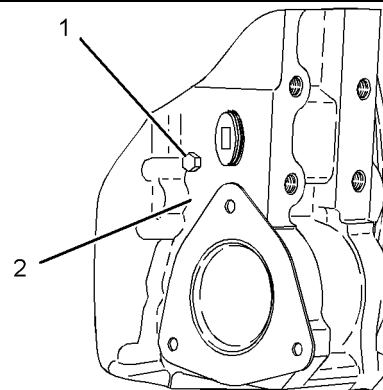

Illustration 44 g01140082  
Timing hole location (typical example)

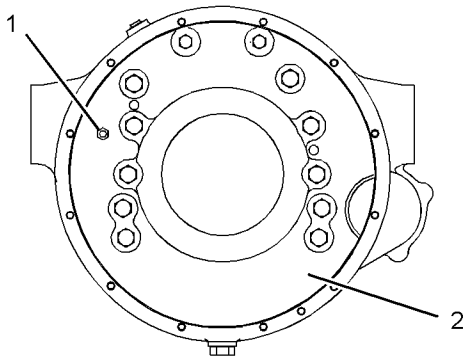

Illustration 45  
Timing hole location (typical example) g01140087

**Note:** The hole for the timing pin may be in either of the following locations:

- Right front face of the flywheel housing
  - Left front face of the flywheel housing
1. Remove plug (1) from flywheel housing (2). Insert Tooling (A) through the timing hole in the flywheel housing.
- Note:** If necessary, use Tooling (B) to adapt the timing pin to a larger timing hole.
2. Carefully thread the pin assembly into the flywheel housing. Release the lock that is on the handle of the tool in order to allow the pin to locate the timing hole that is in the flywheel.
  3. Use Tooling (C), Tooling (D), and a ratchet in order to turn the engine in the direction of normal engine rotation. Normal engine rotation is counterclockwise, as the engine is viewed from the flywheel end.
- Note:** Tooling (E) can be used to turn the crankshaft from the front of the engine.
4. Slowly turn the flywheel until Tooling (A) engages with the hole that is in the flywheel.

If the flywheel has been turned beyond the point of engagement, use the following procedure to readjust the flywheel and try again:

- a. Retract the pin for Tooling (A) and lock the tool in the retracted position.
- b. Turn the flywheel in the direction that is opposite of normal engine rotation. Rotate the engine past the timing hole by at least 30 degrees.

- c. Unlock Tooling (A) in order to locate the timing hole that is in the flywheel. Turn the flywheel in the direction of normal engine rotation until the timing pin engages into the timing hole that is in the flywheel.
5. Use the following procedure in order to determine the stroke position of the no. 1 piston:
    - a. Remove the valve mechanism cover.
    - b. Check the positions of the inlet valves and the exhaust valve for the no. 1 piston.

The no. 1 piston will be in the compression stroke if the following conditions are satisfied:

- No. 1 piston's inlet valves and the exhaust valve is fully closed.
- No. 1 piston's rocker arms can be moved by hand.

If these conditions are not met, use the same conditions to check the stroke position of the no. 6 piston. If the no. 6 piston is in the compression stroke, you must rotate the flywheel for an additional 360 degrees in order to place the no. 1 piston in the compression stroke.

i02486888

## Fuel Quality - Test

**SMCS Code:** 1280-081

This test checks for problems regarding fuel quality. Refer to Diesel Fuels and Your Engine, SEBD0717 for additional details.

Use the following procedure to test for problems regarding fuel quality:

1. Determine if water and/or contaminants are present in the fuel. Check the water separator (if equipped). If a water separator is not present, proceed to Step 2. Drain the water separator, if necessary. A full fuel tank minimizes the potential for overnight condensation.

**Note:** A water separator can appear to be full of fuel when the water separator is actually full of water.



i01823195

2. Determine if contaminants are present in the fuel. Remove a sample of fuel from the bottom of the fuel tank. Visually inspect the fuel sample for contaminants. The color of the fuel is not necessarily an indication of fuel quality. However, fuel that is black, brown, and/or similar to sludge can be an indication of the growth of bacteria or oil contamination. In cold temperatures, cloudy fuel indicates that the fuel may not be suitable for operating conditions. The following methods can be used to prevent wax from clogging the fuel filter:

- Fuel heaters
- Blending fuel with additives
- Utilizing fuel with a low cloud point such as kerosene

Refer to Operation and Maintenance Manual, SEBU6251, "Caterpillar Commercial Diesel Engine Fluids Recommendations", "Fuel Recommendations" for more information.

3. Check fuel API with a 9U-7840 Fluid and Fuel Calibration Gp for low power complaints. The acceptable range of the fuel API is 30 to 45 when the API is measured at 15 °C (60 °F), but there is a significant difference in energy within this range. Refer to Tool Operating Manual, NEHS0607 for API correction factors when a low power problem is present and API is high.

**Note:** A correction factor that is greater than 1 may be the cause of low power and/or poor fuel consumption.

4. If fuel quality is still suspected as a possible cause to problems regarding engine performance, disconnect the fuel inlet line, and temporarily operate the engine from a separate source of fuel that is known to be good. This will determine if the problem is caused by fuel quality. If fuel quality is determined to be the problem, drain the fuel system and replace the fuel filters. Engine performance can be affected by the following characteristics:

- Cetane number of the fuel
- Air in the fuel
- Other fuel characteristics

## Fuel System - Prime

SMCS Code: 1258-548

### WARNING

**Fuel leaked or spilled onto hot surfaces or electrical components can cause a fire. To help prevent possible injury, turn the start switch off when changing fuel filters or water separator elements. Clean up fuel spills immediately.**

If the engine's fuel system is run dry, fill the fuel tank. Then prime the fuel system in order to remove any air bubbles from the system.

### NOTICE

Do not loosen fuel lines at the fuel manifold. The engine components may be damaged and/or loss of priming pressure may occur when the fuel lines are loosened.

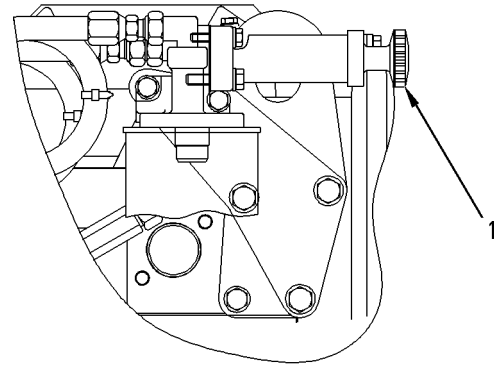

Illustration 46

g00936682

Typical example

Follow these steps in order to prime the fuel system:

1. Locate the fuel priming pump.
2. Operate priming pump's plunger (1) in order to fill the final fuel filter. Continue until you feel resistance.

**Note:** You may need to pump the priming pump for 25 times or more in order to fill the fuel filter. Furthermore, you may need up to 75 pump strokes to fill the fuel supply passage.

3. Push the plunger and tighten the plunger in a counterclockwise direction. Tighten the plunger by hand.
4. After you pressurize the fuel system, promptly crank the engine.

**Note:** Use the engine starting procedure. Refer to Operation and Maintenance Manual, "Engine Starting" in the Operation Section.

i02495025

## Fuel System Pressure - Test

**SMCS Code:** 1250-081; 1256-081

Table 3

Tools Needed		
Part Number	Part Name	Quantity
1U-5470 or 198-4240	Engine Pressure Test Group or Pressure Indicator Tool Gp	1
3Y-2888	Connector	1
3J-1907	O-Ring Seal	1

**Note:** Both the 5P-2720 Probe Adapter and the 5P-2718 Pressure Probe can be used with these tools. Use these additional tools to allow the future installation of pressure probes.

### WARNING

**Fuel leaked or spilled onto hot surfaces or electrical components can cause a fire. Clean up fuel spills immediately.**

### NOTICE

Keep all parts clean from contaminants.

Contaminants may cause rapid wear and shortened component life.

### NOTICE

Care must be taken to ensure that fluids are contained during performance of inspection, maintenance, testing, adjusting and repair of the product. Be prepared to collect the fluid with suitable containers before opening any compartment or disassembling any component containing fluids.

Refer to Special Publication, NENG2500, "Caterpillar Dealer Service Tool Catalog" for tools and supplies suitable to collect and contain fluids on Caterpillar products.

Dispose of all fluids according to local regulations and mandates.

The 1U-5470 Engine Pressure Test Group or the 198-4240 Pressure Indicator Tool Gp can be used in order to check the engine's fuel pressures.

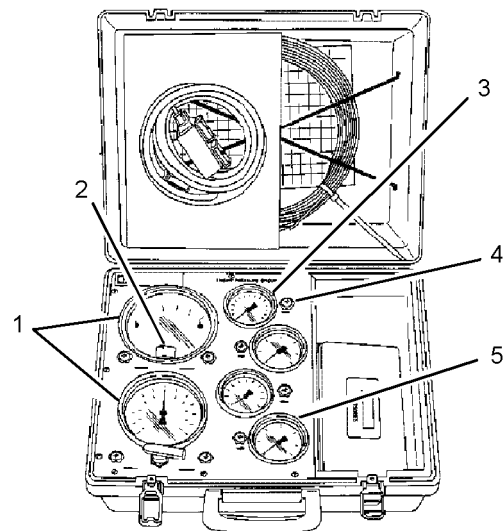

Illustration 47

g01229712

1U-5470 Engine Pressure Test Group

- (1) Pressure indicators
- (2) Zero adjustment screw
- (3) Pressure indicator
- (4) Pressure tap
- (5) Pressure indicator

This tool group has a gauge that is used to register the pressure in the fuel manifolds. The Special Instruction, SEHS8907 is with the tool group.

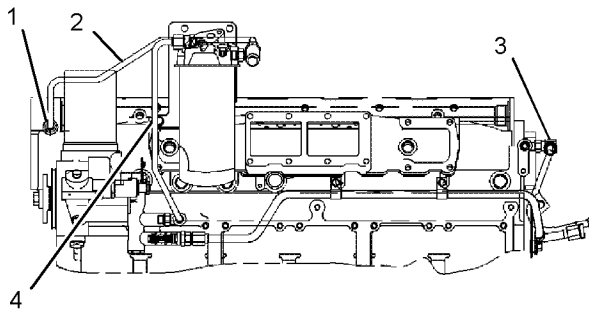

Illustration 48

g01229716

Fuel return line (typical example)

- (1) Fuel supply passage
- (2) Tube assembly (CPU to fuel supply passage)
- (3) Pressure regulator
- (4) Tube assembly (fuel transfer pump to fuel filter)

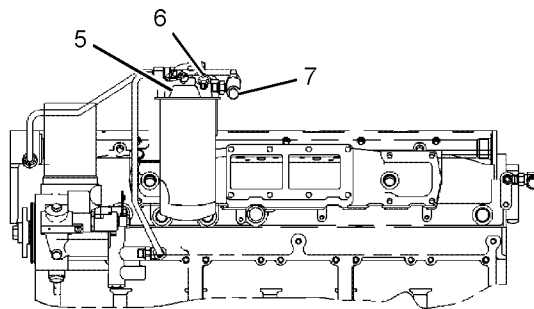

Illustration 49

g01229719

Fuel pressure test (typical example)

- (5) Fuel filter base
- (6) Fuel pressure tap (unfiltered tap)
- (7) Fuel pressure tap (filtered tap)

During both normal operating conditions and load conditions, the fuel pressure should register the following range:

- 400 to 525 kPa (58 to 76 psi)

At low idle, the fuel pressure at the fuel filter's inlet should be at the following amount:

- 400 to 435 kPa (58 to 63 psi)

The fuel pressure to fuel supply passage (1) should be the same amount, if you subtract the change in pressure (delta P) across the filter.

With a new filter, the pressure drop across the fuel filter typically registers the following amount:

- 35 kPa (5 psi)

As abrasive particles collect in the fuel filter, the pressure differential across the filter will increase. As the fuel filter becomes plugged, the pressure differential across the fuel filter may increase to as much as 69 kPa (10 psi) before a significant power loss is detected by the operator. Low fuel pressure will cause cavitation and internal damage to the unit injectors. **The pressure differential across the fuel filter should not exceed 69 kPa (10 psi).**

Pressure regulator (3) is mounted directly in the cylinder head. The regulator is located at the fuel return port toward the rear end of the fuel supply passage (1). The orifice maintains fuel pressure at low engine rpm.

To check the unfiltered fuel pressure, follow this procedure:

1. Remove the plug from fuel pressure tap (6).
2. Install the connector, the seal, and the engine pressure test group to fuel pressure tap (6).

This will obtain the fuel transfer pump pressure.

To check the fuel pressure in the fuel supply passage (1), follow these steps:

1. Remove the plug from fuel pressure tap (7).
2. Install the adapter, the seal, and the engine pressure test group to fuel pressure tap (7).
3. Operate the engine.

**Note:** Make sure that the fuel filter is clean before you check the fuel pressure. A restricted fuel filter causes lower fuel pressure at fuel pressure tap (7) than the fuel pressure at fuel pressure tap (6).

i02237153

i02277454

## Gear Group (Front) - Time

SMCS Code: 1206-531

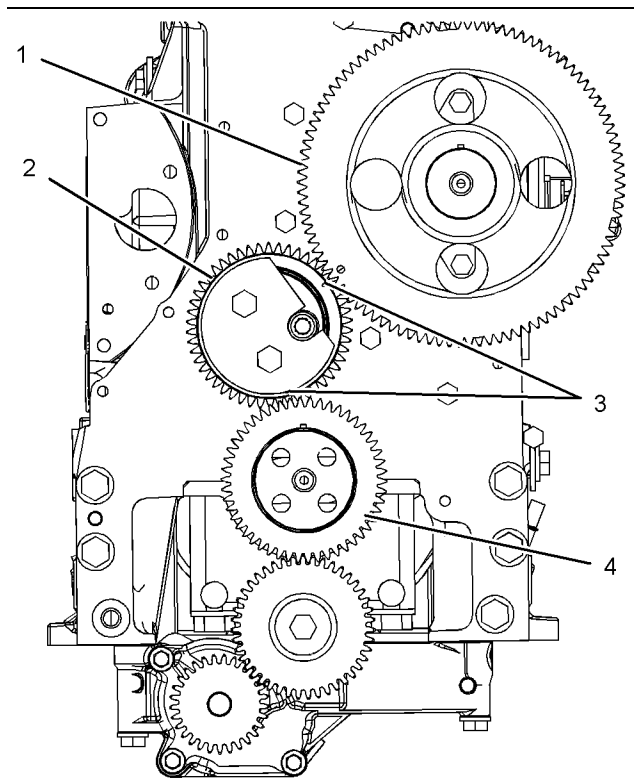

Illustration 50

g01134615

Front gear group

- (1) Camshaft gear and timing reference gear
- (2) Idler gear
- (3) Timing marks
- (4) Crankshaft gear

Correct fuel injection timing and correct valve mechanism operation is determined by the timing reference gear and the alignment of the front gear group. The timing reference gear is located on the camshaft gear. The timing reference gear is used to measure crankshaft rotation. During installation of the front gear, timing marks (3) on idler gear (2) must be in alignment with the timing marks on crankshaft gear (4) and the timing marks on camshaft gear (1).

Check the teeth on the timing reference gear. The teeth should not be defaced. The teeth should have sharp clean edges and the teeth should be free of contaminants.

**Note:** The electronic injection timing must be calibrated after reassembly of the front gear train. Refer to Troubleshooting, "Engine Speed/Timing Sensor - Calibrate".

## Unit Injector - Test

SMCS Code: 1290-081

This procedure assists in identifying the cause for an injector misfiring. Perform this procedure only after performing the Cylinder Cutout Test. Refer to Troubleshooting, "Injector Solenoid Circuit - Test" for more information.

1. Check for air in the fuel, if this procedure has not already been performed. Refer to Testing and Adjusting, "Air in Fuel - Test".

### **WARNING**

**Electrical shock hazard. The electronic unit injector system uses 90-120 volts.**

2. Remove the valve cover and look for broken parts. Repair any broken parts or replace any broken parts that are found. Inspect all wiring for the solenoids. Look for loose connections. Also look for frayed wires or broken wires. Ensure that the connector for the unit injector solenoid is properly connected. Perform a pull test on each of the wires.
3. Look for signs of fuel leakage. Investigate the source of the leaking fuel. Remedy the cause of the fuel leak.
4. Check the valve lash setting for the cylinder of the suspect unit injector. Refer to Testing and Adjusting, "Engine Valve Lash - Inspect/Adjust".
5. Ensure that the bolts that hold the unit injector are tightened to the proper torque. In order to check the torque, loosen the bolts that hold the unit injector. Tighten the bolts to the proper torque. Refer to either the Disassembly and Assembly Manual, "Unit Injector - Install" or the Specifications Manual, "Unit Injector" for the proper tightening procedure.

- 6.** Remove the suspect unit injector and check the unit injector for signs of exposure to coolant. Exposure to coolant will cause rust to form on the injector. If the unit injector shows signs of exposure to coolant, remove the injector sleeve and inspect the injector sleeve. Replace the injector sleeve if the injector sleeve is damaged. Check the unit injector for an excessive brown discoloration that extends beyond the injector tip. If excessive discoloration is found, check the quality of the fuel. Refer to Testing and Adjusting, "Fuel Quality - Test". Replace the seals on the injector and reinstall the injector. Refer to Disassembly and Assembly Manual, "Unit Injector - Install". Also refer to Disassembly and Assembly Manual, "Unit Injector Sleeve - Install". Inspect the injector for deposits of soot that are above the surface of the seat of the injector. Deposits of soot indicate combustion gas leakage. The source of the leak should be found, and the source of the leak should be remedied. The injector will not need to be replaced if combustion gas leakage was the problem.
- 7.** If the problem is not resolved, replace the suspect injector with a new injector. In order to verify that the new injector is working properly, perform the Cylinder Cutout Test. Use the Caterpillar Electronic Technician (ET).

# Air Inlet and Exhaust System

i01696399

## Air Inlet and Exhaust System - Inspect

SMCS Code: 1050-040

### Air Inlet Restriction

There will be a reduction in the performance of the engine if there is a restriction in the air inlet system or the exhaust system.

Table 4

Required Tools		
Part Number	Part Name	Quantity
1U-5470 or 198-4240	Engine Pressure Group or Digital Pressure Indicator	1

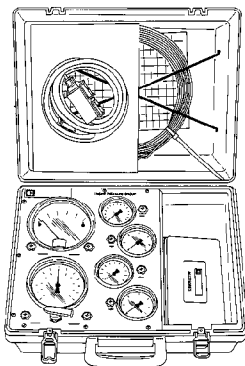

Illustration 51

g00293196

1U-5470 Engine Pressure Group

Refer to Special Instruction, SEHS8907, "Using the 1U-5470 Engine Pressure Group" for the instructions that are needed to use the 1U-5470 Engine Pressure Group. Refer to Operation Manual, NEHS0818, "Using the 198-4240 Pressure Indicator Tool Gp" for the instructions that are needed to use the 198-4240 Pressure Indicator Tool Gp.

1. Inspect the engine air cleaner inlet and ducting in order to ensure that the passageway is not blocked or collapsed.
2. Inspect the engine air cleaner element. Replace a dirty engine air cleaner element with a clean engine air cleaner element.

3. Check for dirt tracks on the clean side of the engine air cleaner element. If dirt tracks are observed, contaminants are flowing past the engine air cleaner element and/or the seal for the engine air cleaner element.

### WARNING

Hot engine components can cause injury from burns. Before performing maintenance on the engine, allow the engine and the components to cool.

### WARNING

Making contact with a running engine can cause burns from hot parts and can cause injury from rotating parts.

When working on an engine that is running, avoid contact with hot parts and rotating parts.

4. Use the differential pressure gauge of the 1U-5470 Engine Pressure Group.

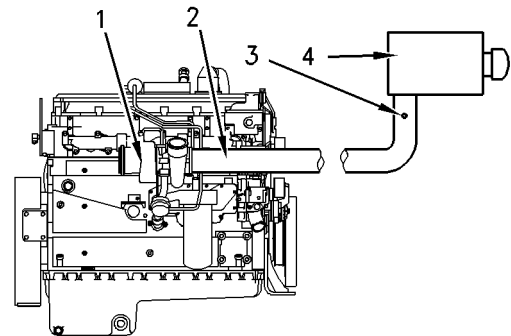

Illustration 52

g00678913

Typical example

- (1) Turbocharger
- (2) Air Inlet Piping
- (3) Test location
- (4) Air cleaner

- a. Connect the vacuum port of the differential pressure gauge to test location (3). Test location (3) can be located anywhere along air inlet piping (2) after engine air cleaner (4) but before turbocharger (1).
- b. Leave the pressure port of the differential pressure gauge open to the atmosphere.
- c. Start the engine. Run the engine in the no-load condition at high idle.
- d. Record the value.

- e. Multiply the value from Step 4.d by 1.8.
- f. Compare the result from Step 4.e to the appropriate values that follow.

The air flow through a used engine air cleaner may have a restriction. The air flow through a plugged engine air cleaner will be restricted to some magnitude. In either case, the restriction must not be more than the following amount:

Maximum restriction ..... 6.2 kPa (25 inch of H<sub>2</sub>O)

The air flow through a new engine air cleaner element must not have a restriction of more than the following amount:

Maximum restriction ..... 3.7 kPa (15 inch of H<sub>2</sub>O)

### Exhaust Restriction

**⚠ WARNING**

The muffler and converter will become extremely hot during engine operation. A hot muffler and converter can cause serious burns. Allow adequate cooling time before working on or near the muffler and converter.

Excessive idling can cause the catalytic converter/muffler to plug. A plugged catalytic converter/muffler will lead to an increase in exhaust back pressure. Operating the engine in extremely cold conditions may cause the catalytic converter/muffler to plug. One indication of a plugged catalytic converter/muffler is poor engine response.

If the engine is operated at low idle or at low load for 24 or more consecutive hours, the engine should be run at rated conditions for five to fifteen minutes. Running the engine at rated conditions should clean out the catalytic converter/muffler.

### Exhaust Back Pressure

Back pressure is the difference in the pressure between the exhaust and the atmospheric air.

Table 5

Required Tools		
Part Number	Part Name	Quantity
1U-5470 or 198-4240	Engine Pressure Group or Digital Pressure Indicator	1

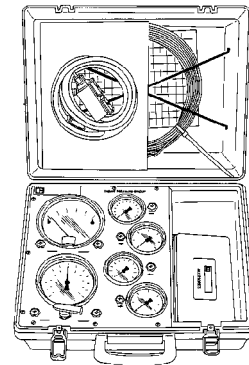

Illustration 53

g00293196

1U-5470 Engine Pressure Group

Refer to Special Instruction, SEHS8907, "Using the 1U-5470 Engine Pressure Group" for the instructions that are needed to use the 1U-5470 Engine Pressure Group. Refer to Operation Manual, NEHS0818, "Using the 198-4240 Pressure Indicator Tool Gp" for the instructions that are needed to use the 198-4240 Pressure Indicator Tool Gp.

**⚠ WARNING**

Hot engine components can cause injury from burns. Before performing maintenance on the engine, allow the engine and the components to cool.

**⚠ WARNING**

Making contact with a running engine can cause burns from hot parts and can cause injury from rotating parts.

When working on an engine that is running, avoid contact with hot parts and rotating parts.

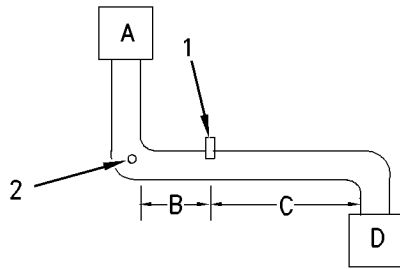

Illustration 54 g00780838

- (A) Catalytic converter/muffler
- (B) 152 mm (6 inches)
- (C) 305 mm (12 inches)
- (D) Turbocharger or Exhaust Manifold
- (1) Preferred Test Location
- (2) Optional Test Location

The location of the back pressure tap is important in order to obtain an accurate back pressure reading. The test location should be located on a straight length of exhaust pipe. This back pressure tap should be located as close as possible to the turbocharger or the exhaust manifold. The tap should be located at least 305 mm (12 inches) downstream of a bend. The tap should have 152 mm (6 inches) before a bend. If a continuous straight length of exhaust that is 457 mm (18 inches) is not available, the tap should be located as close as possible to the neutral axis on an elbow.

If the exhaust is not equipped with a back pressure tap, the following procedure may be use in order to install a pressure tap.

1. Mark the position for the pressure tap.
2. Weld or braze a 1/8 inch NPT half coupling to the exhaust pipe.
3. Drill a 3.18 mm (0.125 inch) hole through the wall of the exhaust inside the half coupling.
4. Remove any burrs from the inside of the exhaust pipe.

Use the differential pressure gauge of the 1U-5470 Engine Pressure Group in order to measure back pressure from the exhaust. Use the following procedure in order to measure back pressure from the exhaust:

## Catalytic Converter/Muffler

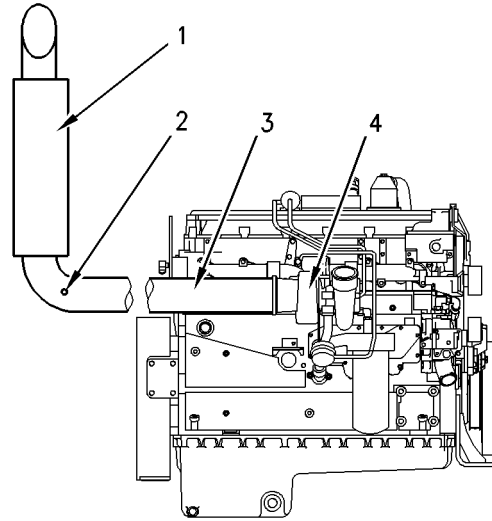

Illustration 55 g00678914

Typical example

- (1) Catalytic converter/muffler
- (2) Test location
- (3) Exhaust piping
- (4) Turbocharger

1. Connect the pressure port of the differential pressure gauge to test location. The test location should be located on a straight length of exhaust pipe. This back pressure tap should be located as close as possible to the turbocharger or the exhaust manifold.
2. Leave the vacuum port of the differential pressure gauge open to the atmosphere.
3. Start the engine. Run the engine in the no-load condition at high idle until the engine reaches normal operating temperature.
4. Record the value.
5. Multiply the value from Step 4 by 1.8.
6. Compare the result from Step 5 to the value that follows.

Maximum back pressure for engines without a catalytic converter/muffler ..... 10.0 kPa  
(40 inch of H<sub>2</sub>O)

Maximum back pressure for catalytic converter/muffler ..... 14.9 kPa (60 inch of H<sub>2</sub>O)

If the maximum back pressure is within the allowable limits, refer to Troubleshooting, "Low/Power/Poor or No Response to Throttle".



i02494968

If the back press exceeds 14.9 kPa (60 inch of H<sub>2</sub>O), replace the catalytic converter/muffler.

## Diesel Particulate Filter

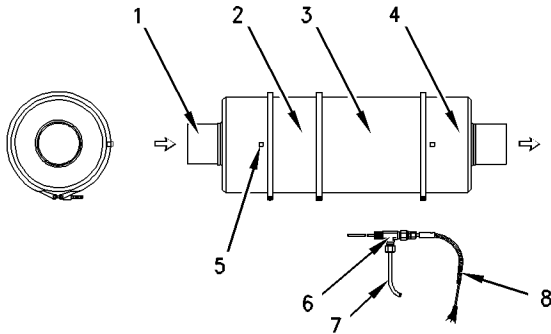

Illustration 56

g00894055

Orientation of the DPF modules

- (1) Inlet module
- (2) Catalyst module
- (3) Filter module
- (4) Outlet module
- (5) Test location
- (6) Tee fitting
- (7) Copper tubing
- (8) Thermocouple

**Note:** Do Not test the exhaust back pressure if the red warning light has been activated. Clean the DPF immediately. Refer to Operation and Maintenance Manual, SEBU7011, "Exhaust Particulate Filter - Clean" for the proper procedure.

1. Connect the pressure port of the differential pressure gauge to test location. The test location is on the Diesel Particulate Filter.
2. Leave the vacuum port of the differential pressure gauge open to the atmosphere.
3. Start the engine and run the engine in the no-load condition at high idle until the engine reaches normal operating temperature.
4. Record the value while the engine is operating at high idle.
5. Multiply the value from 4 by 1.8.
6. Compare the result from Step 5 to the value that follows.

Clean the Diesel Particulate Filter if the back pressure exceeds the following value.

..... 25 kPa (100 inch of H<sub>2</sub>O)

Additional information is available in Operation and Maintenance Manual, "Exhaust Particulate Filter - Clean".

## Turbocharger - Inspect

SMCS Code: 1052-040

### WARNING

Disconnect batteries before performance of any service work.

### WARNING

Hot engine components can cause injury from burns. Before performing maintenance on the engine, allow the engine and the components to cool.

### WARNING

Personal injury can result from rotating and moving parts.

Stay clear of all rotating and moving parts.

Never attempt adjustments while the machine is moving or the engine is running unless otherwise specified.

The machine must be parked on a level surface and the engine stopped.

### NOTICE

Keep all parts clean from contaminants.

Contaminants may cause rapid wear and shortened component life.

### NOTICE

Care must be taken to ensure that fluids are contained during performance of inspection, maintenance, testing, adjusting and repair of the product. Be prepared to collect the fluid with suitable containers before opening any compartment or disassembling any component containing fluids.

Refer to Special Publication, NENG2500, "Caterpillar Dealer Service Tool Catalog" for tools and supplies suitable to collect and contain fluids on Caterpillar products.

Dispose of all fluids according to local regulations and mandates.

Before you begin inspection of the turbocharger, be sure that the inlet air restriction is within the specifications for your engine. Be sure that the exhaust system restriction is within the specifications for your engine. Refer to Systems Operation/Testing and Adjusting, "Air Inlet and Exhaust System - Inspect".

The condition of the turbocharger will have definite effects on engine performance. Use the following inspections and procedures to determine the condition of the turbocharger.

- Inspection of the Compressor and the Compressor Housing
- Inspection of the Turbine Wheel and the Turbine Housing
- Inspection of the Wastegate

## Inspection of the Compressor and the Compressor Housing

Remove air piping from the compressor inlet.

1. Inspect the compressor wheel for damage from a foreign object. If there is damage, determine the source of the foreign object. As required, clean the inlet system and repair the intake system. Replace the turbocharger. If there is no damage, go to Step 3.
2. Clean the compressor wheel and clean the compressor housing if you find buildup of foreign material. If there is no buildup of foreign material, go to Step 3.
3. Turn the rotating assembly by hand. While you turn the assembly, push the assembly sideways. The assembly should turn freely. The compressor wheel should not rub the compressor housing. Replace the turbocharger if the compressor wheel rubs the compressor wheel housing. If there is no rubbing or scraping, go to Step 4.
4. Inspect the compressor and the compressor wheel housing for oil leakage. An oil leak from the compressor may deposit oil in the aftercooler. Drain and clean the aftercooler if you find oil in the aftercooler.
  - a. Check the oil level in the crankcase. If the oil level is too high, adjust the oil level.
  - b. Inspect the air cleaner element for restriction. If restriction is found, correct the problem.

- c. Inspect the engine crankcase breather. Clean the engine crankcase breather or replace the engine crankcase breather if the engine crankcase breather is plugged.
- d. Remove the oil drain line of the turbocharger. Inspect the drain opening. Inspect the oil drain line. Inspect the area between the bearings of the rotating assembly shaft. Look for oil sludge. Inspect the oil drain hole for oil sludge. Inspect the oil drain line for oil sludge in the drain line. If necessary, clean the rotating assembly shaft. If necessary, clean the oil drain hole. If necessary, clean the oil drain line.
- e. If Steps 4.a through 4.d did not reveal the source of the oil leakage, the turbocharger has internal damage. Replace the turbocharger.

## Inspection of the Turbine Wheel and the Turbine Housing

Remove the air piping from the turbine outlet casing.

1. Inspect the turbine for damage by a foreign object. If there is damage, determine the source of the foreign object. Replace the turbocharger. If there is no damage, go to Step 2.
2. Inspect the turbine wheel for buildup of carbon and other foreign material. Inspect the turbine housing for buildup of carbon and foreign material. Clean the turbine wheel and clean the turbine housing if you find buildup of carbon or foreign material. If there is no buildup of carbon or foreign material, go to Step 3.
3. Turn the rotating assembly by hand. While you turn the assembly, push the assembly sideways. The assembly should turn freely. The turbine wheel should not rub the turbine wheel housing. Replace the turbocharger if the turbine wheel rubs the turbine wheel housing. If there is no rubbing or scraping, go to Step 4.
4. Inspect the turbine and the turbine wheel housing for oil leakage. Inspect the turbine and the turbine wheel housing for oil coking. Some oil coking may be cleaned. Heavy oil coking may require replacement of the turbocharger. If the oil is coming from the turbocharger center housing go to Step 4.a. Otherwise go to "Inspection of the Wastegate".

- a. Remove the oil drain line of the turbocharger . Inspect the drain opening. Inspect the area between the bearings of the rotating assembly shaft. Look for oil sludge. Inspect the oil drain hole for oil sludge. Inspect the oil drain line for oil sludge. If necessary, clean the rotating assembly shaft. If necessary, clean the drain opening. If necessary, clean the drain line.
- b. If crankcase pressure is high, or if the oil drain is restricted, pressure in the center housing may be greater than the pressure of the turbine housing. Oil flow may be forced in the wrong direction and the oil may not drain. Check the crankcase pressure and correct any problems.
- c. If the oil drain line is damaged, replace the oil drain line.
- d. Check the routing of the oil drain line. Eliminate any sharp restrictive bends. Make sure that the oil drain line is not too close to the engine exhaust manifold.
- e. If Steps 4.a through 4.d did not reveal the source of the oil leakage, the turbocharger has internal damage. Replace the turbocharger.

## Inspection of the Wastegate

The turbocharger senses boost pressure which actuates the wastegate valve. The wastegate valve controls the amount of exhaust gas that is allowed to bypass the turbine side of the turbocharger. Regulating the amount of exhaust gas that enters the turbocharger regulates the rpm of the turbocharger.

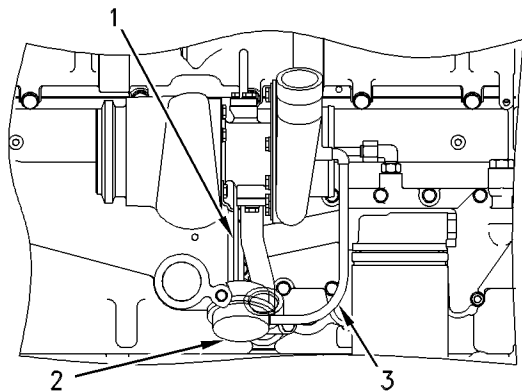

When the engine operates in conditions of low boost (lug), a spring presses against a diaphragm in canister (2). This moves actuating rod (1) in order to close the wastegate valve. Then, the turbocharger can operate at maximum performance.

As the boost pressure increases against the diaphragm in canister (2), the wastegate valve opens. The rpm of the turbocharger becomes limited. This limitation occurs because a portion of the exhaust gases bypass the turbine wheel of the turbocharger.

The following levels of boost pressure indicate a problem with the wastegate valve:

- Too high at full load conditions
- Too low at all lug conditions

The Technical Marketing Information (TMI) provides the correct pressure for the inlet manifold.

To check the operation of the wastegate valve, verify the correct pressure for the wastegate valve. This can be accomplished by referring to the letter designation that is stamped on the actuating lever of the wastegate valve. This letter designation indicates a corresponding amount of pressure.

**Note:** Refer to Table 6 for the letter designation and the corresponding amounts of pressure.

Remove the air line, and slowly apply the corresponding amount of pressure to the canister. DO NOT EXCEED 200 kPa (29 psi).

When the external supply of air that is connected to line (3) reaches the corresponding pressure for the wastegate valve, the actuating lever should move by  $0.50 \pm 0.25$  mm ( $0.020 \pm 0.010$  inch). If the actuating lever does NOT move by this amount, replace the turbine's housing assembly of the turbocharger. This housing assembly includes the wastegate valve. If necessary, replace the complete turbocharger.

**Note:** The housing assembly for the wastegate turbine is preset at the factory and no adjustments can be made.

Illustration 57

g00295815

Typical Example

- (1) Actuating Rod
- (2) Canister
- (3) Line

Table 6

i02277487

Amount Of Pressure That Is Required To Check The Wastegate Valve		
Letter Designation	kPa	psig
B	156	(23)
C	153	(22)
D	124	(18)
E	130	(19)
F	135	(20)
G	180	(26)
H	144	(21)
J	188	(27)
K	155	(23)
M	200	(29)
V	161	(23)
W	164	(24)
AG	148	(21)

The boost pressure controls the maximum rpm of the turbocharger, because the boost pressure controls the position of the wastegate. The following factors also affect the maximum rpm of the turbocharger:

- Engine rating
- Horsepower demand on the engine
- High idle rpm
- Height above sea level for engine operation
- Inlet air restriction
- Exhaust system restriction

**NOTICE**

If the high idle rpm or the engine rating is higher than given in the Technical Marketing Information (TMI) for the height above sea level at which the engine is operated, there can be damage to engine or to turbocharger parts. Damage will result when increased heat and/or friction due to the higher engine output goes beyond the engine cooling and lubrication system's abilities.

## Inlet Manifold Pressure - Test

**SMCS Code:** 1058-081

The efficiency of an engine can be checked by making a comparison of the pressure in the inlet manifold with the information given in the Technical Marketing Information (TMI). This test is used when there is a decrease of horsepower from the engine, yet there is no real sign of a problem with the engine.

The correct pressure for the inlet manifold is listed in the TMI. Development of this information is performed under the following conditions:

- 96 kPa (28.8 in Hg) dry barometric pressure
- 25 °C (77 °F) outside air temperature
- 35 API rated fuel

Any change from these conditions can change the pressure in the inlet manifold. The outside air may have a higher temperature and a lower barometric pressure than the values that are given above. This will cause a lower inlet manifold pressure measurement than the pressure in the TMI. Outside air that has both a lower temperature and a higher barometric pressure will cause a higher inlet manifold pressure measurement.

A difference in fuel density will change horsepower (stall speed) and boost. If the fuel is rated above 35 API, the pressure in the inlet manifold can be less than the pressure that appears in the TMI. If the fuel is rated below 35 API, the pressure in the inlet manifold can be more than the pressure that appears in the TMI. **Be sure that the air inlet or the exhaust does not have a restriction when you are making a check of the pressure.**

**Note:** Caterpillar Electronic Technician (ET) may be used to check the pressure in the inlet manifold.

Table 7

Tools Needed		
Part Number	Part Description	Qty
1U-5470 or 198-4240	Engine Pressure Group or Digital Pressure Indicator	1

i02100926

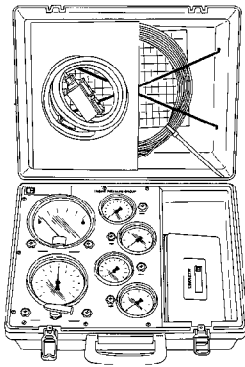

Illustration 58 g00293196  
1U-5470 Engine Pressure Test Group

Refer to Special Instruction, SEHS8907, "Using the 1U-5470 Engine Pressure Group" for the instructions that are needed to use the 1U-5470 Engine Pressure Test Group. Refer to Operation Manual, NEHS0818, "Using the 198-4240 Digital Pressure Indicator" for the instructions that are needed to use the 198-4240 Digital Pressure Indicator.

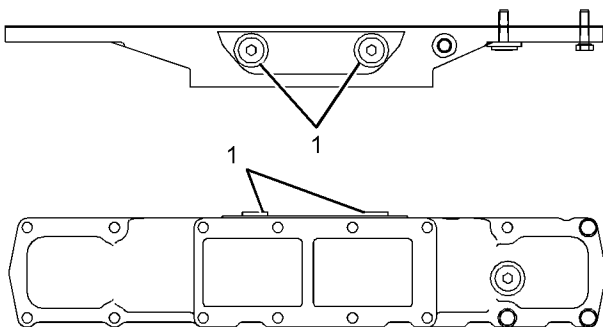

Illustration 59 g01140264  
Pressure Test Location  
(1) Plug

Use the following procedure in order to measure the inlet manifold pressure:

1. Remove plug (1) from the air inlet cover.
2. Connect the 1U-5470 Engine Pressure Group to the air inlet cover at the pressure test location.

**Note:** A tee fitting or some other plumbing component will be necessary to allow the boost pressure sensor to be connected with a test location.

3. Record the value.
4. Compare the value that was recorded in Step 3 to the pressure that is given in the TMI.

## Exhaust Temperature - Test

SMCS Code: 1088-081

Table 8

Tools Needed		
Part Number	Part Name	Quantity
164-3310	Infrared Thermometer	1

When the engine runs at low idle, the temperature of an exhaust manifold port can indicate the condition of a unit injector:

A low temperature indicates that no fuel is flowing to the cylinder. An inoperative unit injector pump could cause this low temperature.

A very high temperature can indicate that too much fuel is flowing to the cylinder. A malfunctioning unit injector could cause this very high temperature.

Use the 164-3310 Infrared Thermometer to check this exhaust temperature. You can find operating instructions and maintenance instructions inside the Operator's Manual, NEHS0630.

i02277538

## Aftercooler - Test

SMCS Code: 1063-081

Table 9

Required Tools		
Part Number	Part Name	Quantity
1U-5470 or 198-4240	Engine Pressure Group or Digital Pressure Indicator	1
FT-1984	Aftercooler Testing Group	1
FT-1438	Aftercooler Gp (DYNAMOMETER TEST)	1

## Visual Inspection

Inspect the following parts at each oil change:

- Air lines
- Hoses
- Gasket joints

**⚠ WARNING**

**Pressurized air can cause personal injury. When pressurized air is used for cleaning, wear a protective face shield, protective clothing, and protective shoes.**

Ensure that the constant torque hose clamps are tightened to the correct torque. Check the welded joints for cracks. Ensure that the brackets are tightened in the correct positions. Ensure that the brackets are in good condition. Use compressed air to clean any debris or any dust from the aftercooler core assembly. Inspect the cooler core fins for the following conditions:

- Damage
- Debris
- Corrosion

Use a stainless steel brush to remove any corrosion. Ensure that you use soap and water.

**Note:** When parts of the air-to-air aftercooler system are repaired, a leak test is recommended. When parts of the air-to-air aftercooler system are replaced, a leak test is recommended.

The use of winter fronts or shutters is discouraged with air-to-air aftercooled systems.

### Inlet Manifold Pressure

Normal inlet manifold pressure with high exhaust temperature can be caused by blockage of the fins of the aftercooler core. Clean the fins of the aftercooler core. Refer to “Visual Inspection” for the cleaning procedure.

Low inlet manifold pressure and high exhaust manifold temperature can be caused by any of the following conditions:

**Plugged air cleaner** – Clean the air cleaner or replace the air cleaner, as required. Refer to the Operation and Maintenance Manual, “Engine Air Cleaner Element - Clean/Replace”.

**Blockage in the air lines** – Blockage in the air lines between the air cleaner and the turbocharger must be removed.

**Aftercooler core leakage** – Aftercooler core leakage should be pressure tested. Refer to “Aftercooler Core Leakage” topic for the testing procedure.

**Leakage of the induction system** – Any leakage from the pressure side of the induction system should be repaired.

**Inlet manifold leak** – An inlet manifold leak can be caused by the following conditions: loose fittings and plugs, missing fittings and plugs, damaged fittings and plugs, and leaking inlet manifold gasket.

### Aftercooler Core Leakage

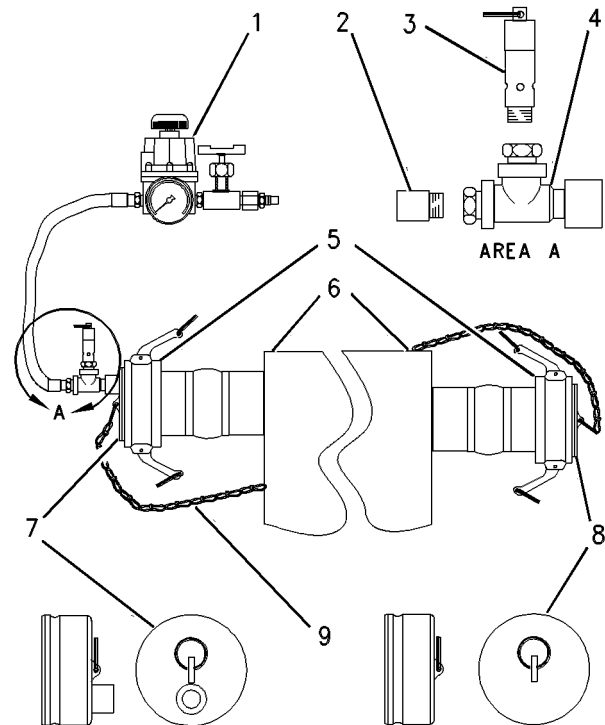

Illustration 60

g01134323

FT - 1984 Aftercooler Testing Group

- (1) Regulator and valve assembly
- (2) Nipple
- (3) Relief valve
- (4) Tee
- (5) Coupler
- (6) Aftercooler
- (7) Dust plug
- (8) Dust plug
- (9) Chain

A low power problem in the engine can be the result of aftercooler leakage. Aftercooler system leakage can result in the following problems:

- Low power
- Low boost pressure
- Black smoke
- High exhaust temperature

**NOTICE**

Remove all air leaks from the system to prevent engine damage. In some operating conditions, the engine can pull a manifold vacuum for short periods of time. A leak in the aftercooler or air lines can let dirt and other foreign material into the engine and cause rapid wear and/or damage to engine parts.

A large leak of the aftercooler core can often be found by making a visual inspection. To check for smaller leaks, use the following procedure:

1. Disconnect the air pipes from the inlet and outlet side of the aftercooler core.

**WARNING**

**Dust plug chains must be installed to the aftercooler core or to the radiator brackets to prevent possible injury while you are testing. Do not stand in front of the dust plugs while you are testing.**

2. Install couplers (5) on each side of the aftercooler core. Also, install dust plugs (7) and (8). These items are included with the FT - 1984 Aftercooler Testing Group.

**Note:** Installation of additional hose clamps on the hump hoses is recommended in order to prevent the hoses from bulging while the aftercooler core is being pressurized.

**NOTICE**

Do not use more than 240 kPa (35 psi) of air pressure or damage to the aftercooler core can be the result.

3. Install the regulator and valve assembly (1) on the outlet side of the aftercooler core assembly. Also, attach the air supply.
4. Open the air valve and pressurize the aftercooler to 205 kPa (30 psi). Shut off the air supply.
5. Inspect all connection points for air leakage.
6. The aftercooler system's pressure should not drop more than 35 kPa (5 psi) in 15 seconds.
7. If the pressure drop is more than the specified amount, use a solution of soap and water to check all areas for leakage. Look for air bubbles that will identify possible leaks. Replace the aftercooler core, or repair the aftercooler core, as needed.

**WARNING**

**To help prevent personal injury when the tooling is removed, relieve all pressure in the system slowly by using an air regulator and a valve assembly.**

8. After the testing, remove the FT - 1984 Aftercooler Testing Group. Reconnect the air pipes on both sides of the aftercooler core assembly.

**Air System Restriction**

Illustration 61

g00581364

Pressure measurements should be taken at the inlet manifold (1) and at the turbocharger outlet (2).

Use the differential pressure gauge of the 1U-5470 Engine Pressure Group or use the 198-4240 Digital Pressure Indicator. Use the following procedure in order to measure the restriction of the aftercooler:

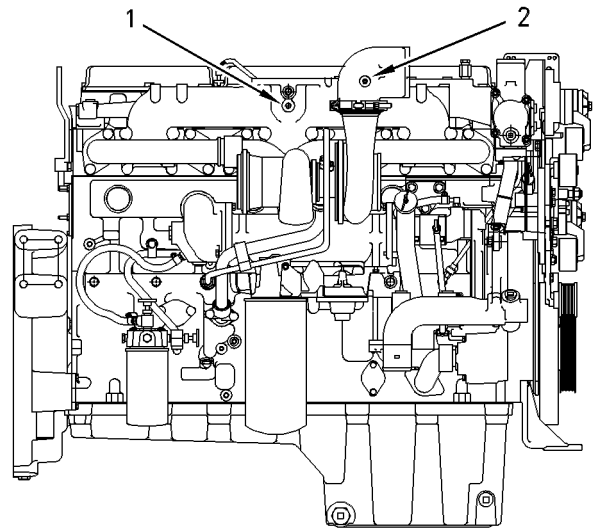
1. Connect the vacuum port of the differential pressure gauge to port (1).
2. Connect the pressure port of the differential pressure gauge to port (2).
3. Record the value.

The air lines and the cooler core must be inspected for internal restriction when both of the following conditions are met:

- Air flow is at a maximum level.
- Total air pressure drop of the charged system exceeds 16.9 kPa (5 in Hg).

If a restriction is discovered, proceed with the following tasks, as required:

- Clean
- Repair
- Replacement

## Turbocharger Failure

### WARNING

Personal injury can result from air pressure.

Personal injury can result without following proper procedure. When using pressure air, wear a protective face shield and protective clothing.

Maximum air pressure at the nozzle must be less than 205 kPa (30 psi) for cleaning purposes.

If a turbocharger failure occurs, remove the air-to-air aftercooler core. Internally flush the air-to-air aftercooler core with a solvent that removes oil and other foreign substances. Shake the air-to-air aftercooler core in order to eliminate any trapped debris. Wash the aftercooler with hot, soapy water. Thoroughly rinse the aftercooler with clean water and blow dry the aftercooler with compressed air. Blow dry the assembly in the reverse direction of normal air flow. To make sure that the whole system is clean, carefully inspect the system.

#### NOTICE

Do not use caustic cleaners to clean the air-to-air aftercooler core.

Caustic cleaners will attack the internal metals of the core and cause leakage.

## Dynamometer Test

In hot ambient temperatures, chassis dynamometer tests for models with an air-to-air aftercooler can add a greater heat load to the jacket water cooling system. Therefore, the jacket water cooling system's temperature must be monitored. The following measurements may also need a power correction factor:

- Inlet air temperature
- Fuel API rating
- Fuel temperature
- Barometric pressure

With dynamometer tests for engines, use the FT - 1438 Aftercooler Gp (DYNAMOMETER TEST). This tool provides a water cooled aftercooler in order to control the inlet air temperature to 43 °C (110 °F).

i01281928

## Engine Crankcase Pressure (Blowby) - Test

SMCS Code: 1215; 1317

Table 10

Tools Needed		
Part Number	Part Name	Quantity
8T - 2700	Blowby/Air Flow Indicator	1

Damaged pistons or damaged rings can cause too much pressure in the crankcase. This condition will cause the engine to run rough. There will be more than the normal amount of fumes (blowby) rising from the crankcase breather. The breather can then become restricted in a very short time. This condition can cause oil leakage at gaskets and seals that would not normally have leakage. Blowby can also be caused by worn valve guides or by a failed turbocharger seal.

**Note:** The electronic service tool can be used to measure crankcase pressure.

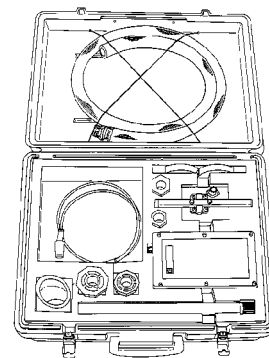

Illustration 62

g00286269

8T - 2700 Blowby/Air Flow Indicator

The 8T - 2700 Blowby/Air Flow Indicator is used to check the amount of blowby. Refer to Special Instruction, SEHS8712, "Using the 8T - 2700 Blowby/Air Flow Indicator" for the test procedure for checking the blowby.



i01120286

## Compression - Test

**SMCS Code:** 1215

An engine that runs roughly can have a leak at the valves. An engine that runs roughly can also have valves that need an adjustment. Remove the head and inspect the valves and valve seats. This is necessary to find those small defects that would not normally cause problems. Repairs of these problems are normally performed when you are reconditioning the engine.

i02277566

## Engine Valve Lash - Inspect/Adjust

**SMCS Code:** 1102-025

### **⚠ WARNING**

To prevent possible injury, do not use the starter to turn the flywheel.

Hot engine components can cause burns. Allow additional time for the engine to cool before measuring valve clearance.

### **⚠ WARNING**

This engine uses high voltage to control the fuel injectors.

Disconnect electronic fuel injector enable circuit connector to prevent personal injury.

Do not come in contact with the fuel injector terminals while the engine is running.

**Note:** Valve lash is measured between the rocker arm and the bridge for the inlet valves. Valve lash is measured between the rocker arm and the valve stem for the exhaust valve. All of the clearance measurements and the adjustments must be made with the engine stopped. The valves must be fully closed.

## Valve Lash Check

An adjustment is not necessary if the measurement of the valve lash is in the acceptable range. Adjust the valve lash while the engine is stopped. The range is specified in Table 11.

Table 11

	Inlet Valves	Exhaust Valves
<b>Valve Lash Check (Stopped Engine)</b>	0.38 ± 0.08 mm (0.015 ± 0.003 inch)	0.64 ± 0.08 mm (0.025 ± 0.003 inch)
<b>TC Compression Stroke</b>	1-2-4	1-3-5
<b>TC Exhaust Stroke<sup>(1)</sup></b>	3-5-6	2-4-6
<b>Firing Order</b>	1-5-3-6-2-4 <sup>(2)</sup>	

<sup>(1)</sup> 360° from TC compression stroke

<sup>(2)</sup> The No. 1 cylinder is at the front of the engine.

If the measurement is not within this range adjustment is necessary. See Testing And Adjusting, "Valve Lash And Valve Bridge Adjustment".

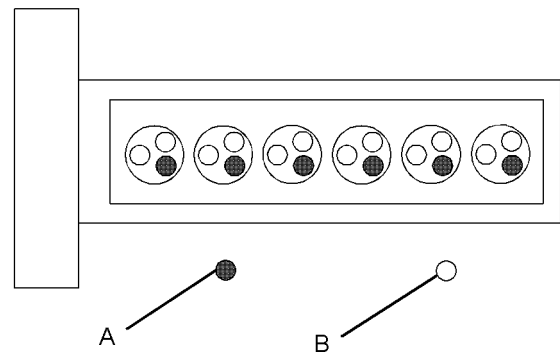

Illustration 63

g01105757

Cylinder and Valve Location

(A) Exhaust valve

(B) Inlet valves

## Valve Lash and Valve Bridge Adjustment

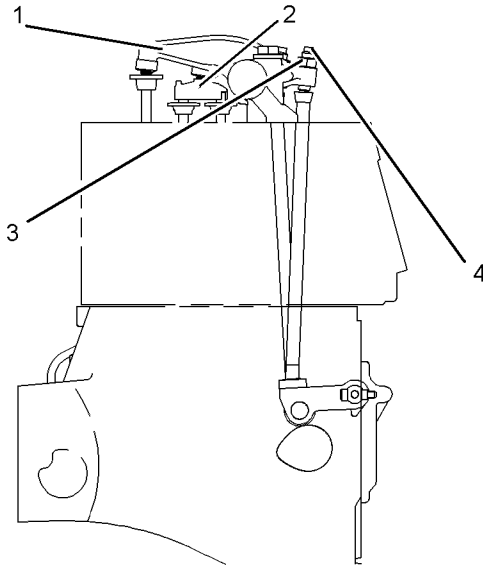

Illustration 64

g01109236

- (1) Exhaust rocker arm
- (2) Inlet valve bridge
- (3) Rocker arm adjustment screw locknut for the exhaust rocker arm
- (4) Rocker arm adjustment screw for the exhaust rocker arm

Table 12

Valve Lash	
Valves	Dimension of Gauge
Inlet	0.38 ± 0.08 mm (0.015 ± 0.003 inch)
Exhaust	0.64 ± 0.08 mm (0.025 ± 0.003 inch)

Adjust the valve lash while the engine is stopped.

1. Put the No. 1 piston at the top center position on the compression stroke. Refer to Testing and Adjusting, "Finding Top Center Position for No. 1 Piston".

Table 13

TC Compression Stroke	Inlet Valves	Exhaust Valves
Valve lash	0.38 ± 0.08 mm (0.015 ± 0.003 inch)	0.64 ± 0.08 mm (0.025 ± 0.003 inch)
Cylinders	1-2-4	1-3-5

2. Adjust the valve lash according to Table 13.

- a. Lightly tap the rocker arm at the top of the adjustment screw with a soft mallet. This will ensure that the lifter roller seats against the camshaft's base circle.
  - b. Loosen the adjustment locknut.
  - c. Place the appropriate feeler gauge between rocker arm and the valve bridge. Then, turn the adjustment screw in a clockwise direction. Slide the feeler gauge between the rocker arm and the valve bridge. Continue turning the adjustment screw until a slight drag is felt on the feeler gauge. Remove the feeler gauge.
  - d. Tighten the adjustment locknut to a torque of 30 ± 7 N·m (22 ± 5 lb ft). Do not allow the adjustment screw to turn while you are tightening the adjustment locknut. Recheck the valve lash after tightening the adjustment locknut.
3. Remove the timing bolt and turn the flywheel by 360 degrees in the direction of engine rotation. This will put the No. 6 piston at the top center position on the compression stroke. Install the timing bolt in the flywheel.

Table 14

TC Exhaust Stroke <sup>(3)</sup>	Inlet Valves	Exhaust Valves
Valve lash	0.38 ± 0.08 mm (0.015 ± 0.003 inch)	0.64 ± 0.08 mm (0.025 ± 0.003 inch)
Cylinders	3-5-6	2-4-6

<sup>(3)</sup> Position for No. 1 cylinder

4. Adjust the valve lash according to Table 14.
  - a. Lightly tap the rocker arm at the top of the adjustment screw with a soft mallet. This will ensure that the lifter roller seats against the camshaft's base circle.
  - b. Loosen the adjustment locknut.
  - c. Place the appropriate feeler gauge between rocker arm and the valve bridge. Then, turn the adjustment screw in a clockwise direction. Slide the feeler gauge between the rocker arm and the valve bridge. Continue turning the adjustment screw until a slight drag is felt on the feeler gauge. Remove the feeler gauge.
  - d. Tighten the adjustment locknut to a torque of 30 ± 7 N·m (22 ± 5 lb ft). Do not allow the adjustment screw to turn while you are tightening the adjustment locknut. Recheck the valve lash after tightening the adjustment locknut.

5. Remove the timing bolt from the flywheel after all adjustments to the valve lash have been made. Reinstall the timing cover.

# Lubrication System

i01565985

## Engine Oil Pressure - Test

SMCS Code: 1304-081

### Measuring Engine Oil Pressure

#### WARNING

Work carefully around an engine that is running. Engine parts that are hot, or parts that are moving, can cause personal injury.

#### NOTICE

Keep all parts clean from contaminants.

Contaminants may cause rapid wear and shortened component life.

#### NOTICE

Care must be taken to ensure that fluids are contained during performance of inspection, maintenance, testing, adjusting and repair of the product. Be prepared to collect the fluid with suitable containers before opening any compartment or disassembling any component containing fluids.

Refer to Special Publication, NENG2500, "Caterpillar Tools and Shop Products Guide" for tools and supplies suitable to collect and contain fluids on Caterpillar products.

Dispose of all fluids according to local regulations and mandates.

Table 15

Required Tools		
Part Number	Part Name	Quantity
1U-5470 or 198-4240	Engine Pressure Group or Digital Pressure Indicator	1
8J-7844	Adapter Fitting	1
3K-0360	O-Ring Seal	1
4M-5317 or 5P-2720	Terminal Bushing or Probe Adapter	1

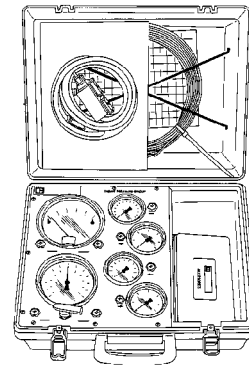

Illustration 65

g00296486

1U-5470 Engine Pressure Group

The 1U-5470 Engine Pressure Group measures the oil pressure in the system. This engine tool group can read the oil pressure inside the oil manifold.

**Note:** Refer to Special Instruction, SEHS8907, "Using the 1U-5470 Engine Pressure Group" for more information on using the 1U-5470 Engine Pressure Group.

**Note:** The engine oil pressure can also be measured by using an electronic service tool. Refer to Troubleshooting for information on the use of the electronic technician.

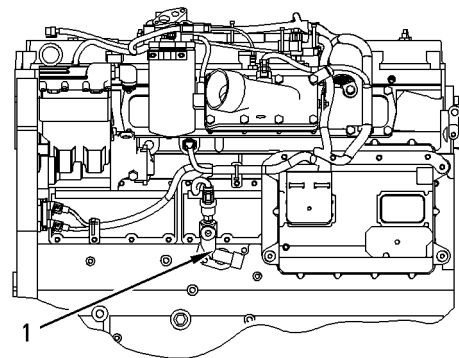

Illustration 66

g00864075

Oil Gallery Plug

(1) Plug.

**1.** Install the 1U-5470 Engine Pressure Group into oil gallery plug (1).

**Note:** Engine oil pressure to the camshaft and main bearings should be checked on each side of the cylinder block at oil gallery plug (1).

2. Start the engine. Run the engine with SAE 10W30 or SAE 15W40 oil. The information in the engine oil pressure graph is invalid for other oil viscosities. Refer to Operation and Maintenance Manual, "Engine Oil" for the recommendations of engine oil.

**Note:** Allow the engine to reach operating temperature before you perform the pressure test.

**Note:** The engine oil temperature should not exceed 115°C (239°F).

3. Record the value of the engine oil pressure when the engine has reached operating temperature.
4. Locate the point that intersects the lines for the engine rpm and for the oil pressure on the engine oil pressure graph.

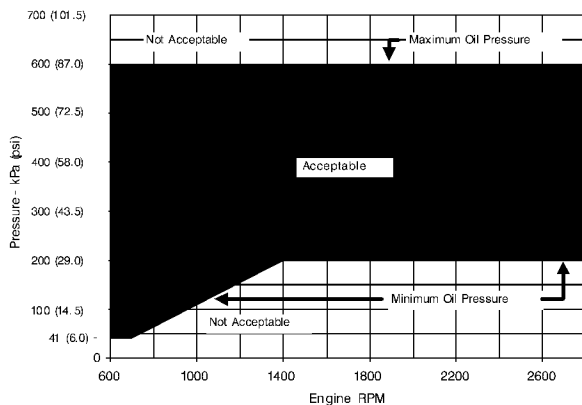

Illustration 67

g00866125

Engine Oil Pressure Graph

5. The results must fall within the "ACCEPTABLE" range on the chart. A problem exists when the results fall within the "NOT ACCEPTABLE" range on the chart. The problem needs to be corrected. Engine failure or a reduction in engine life can be the result if engine operation is continued with oil manifold pressure outside this range.

**Note:** A record of engine oil pressure can be used as an indication of possible engine problems or damage. A possible problem could exist if the oil pressure suddenly increases or decreases 70 kPa (10 psi) and the oil pressure is in the "ACCEPTABLE" range. The engine should be inspected and the problem should be corrected.

6. Compare the recorded engine oil pressure with the oil pressure indicators on the instrument panel and the engine oil pressure that is displayed on the electronic service tool.
7. An engine oil pressure indicator that has a defect or an engine oil pressure sensor that has a defect can give a false indication of a low oil pressure or a high oil pressure. If there is a notable difference between the engine oil pressure readings make necessary repairs.
8. If low engine oil pressure is determined, refer to "Reasons for Low Engine Oil Pressure".
9. If high engine oil pressure is determined, refer to "Reason for High Engine Oil Pressure".

## Reasons for Low Engine Oil Pressure

### NOTICE

Keep all parts clean from contaminants.

Contaminants may cause rapid wear and shortened component life.

### NOTICE

Care must be taken to ensure that fluids are contained during performance of inspection, maintenance, testing, adjusting and repair of the product. Be prepared to collect the fluid with suitable containers before opening any compartment or disassembling any component containing fluids.

Refer to Special Publication, NENG2500, "Caterpillar Tools and Shop Products Guide" for tools and supplies suitable to collect and contain fluids on Caterpillar products.

Dispose of all fluids according to local regulations and mandates.

- Engine oil level is low. Refer to Step 1.
- Engine oil is contaminated. Refer to Step 2.
- The engine oil bypass valves are open. Refer to Step 3.
- The engine lubrication system is open. Refer to Step 4.
- The oil suction tube has a leak or a restricted inlet screen. Refer to Step 5.
- The engine oil pump is faulty. Refer to Step 6.
- Engine Bearings have excessive clearance. Refer to Step 7.

1. Check the engine oil level in the crankcase. The oil level can possibly be too far below the oil pump supply tube. This will cause the oil pump not to have the ability to supply enough lubrication to the engine components. If the engine oil level is low add engine oil in order to obtain the correct engine oil level. Refer to Operation and Maintenance Manual, "Engine Oil" for the recommendations of engine oil.
  2. Engine oil that is contaminated with fuel or coolant will cause low engine oil pressure. High engine oil level in the crankcase can be an indication of contamination. Determine the reason for contamination of the engine oil and make the necessary repairs. Replace the engine oil with the approved grade of engine oil. Also replace the engine oil filter. Refer to Operation and Maintenance Manual, "Engine Oil" for the recommendations of engine oil.
- 
- NOTICE**
- Caterpillar oil filters are built to Caterpillar specifications. Use of an oil filter not recommended by Caterpillar could result in severe engine damage to the engine bearings, crankshaft, etc., as a result of the larger waste particles from unfiltered oil entering the engine lubricating system. Only use oil filters recommended by Caterpillar.
- 
3. If the engine oil bypass valves are held in the open position, a reduction in the oil pressure can be the result. This may be due to debris in the engine oil. If the engine oil bypass valves are stuck in the open position, remove each engine oil bypass valve and clean each bypass valve in order to correct this problem. You must also clean each bypass valve bore. Install new engine oil filters. For information on the repair of the engine oil bypass valves, refer to Disassembly and Assembly, "Engine Oil Filter Base - Disassemble".
  4. An oil line or an oil passage that is open, broken, or disconnected will cause low engine oil pressure. An open lubrication system could be caused by a piston cooling jet that is missing or damaged.
- Note:** The piston cooling jets direct engine oil toward the bottom of the piston in order to cool the piston. This also provides lubrication for the piston pin. Breakage, a restriction, or incorrect installation of the piston cooling jets will cause seizure of the piston.
5. The inlet screen of the oil suction tube for the engine oil pump can have a restriction. This restriction will cause cavitation and a loss of engine oil pressure. Check the inlet screen on the oil pickup tube and remove any material that may be restricting engine oil flow. Low engine oil pressure may also be the result of the oil pickup tube that is drawing in air. Check the joints of the oil pickup tube for cracks or a damaged O-ring seal. Remove the engine oil pan in order to gain access to the oil pickup tube and the oil screen. Refer to Disassembly and Assembly, "Engine Oil Pan - Remove and Install" for more information.
  6. Check the following problems that may occur to the engine oil pump.
    - a. Air leakage in the supply side of the oil pump will also cause cavitation and loss of oil pressure. Check the supply side of the oil pump and make necessary repairs. For information on the repair of the engine oil pump, refer to Disassembly and Assembly, "Engine Oil Pump - Remove".
    - b. Oil pump gears that have too much wear will cause a reduction in oil pressure. Repair the engine oil pump. For information on the repair of the engine oil pump, refer to Disassembly and Assembly, "Engine Oil Pump - Remove".
  7. Excessive clearance at engine bearings will cause low engine oil pressure. Check the engine components that have excessive bearing clearance and make the necessary repairs.

## Reason for High Engine Oil Pressure

### NOTICE

Keep all parts clean from contaminants.

Contaminants may cause rapid wear and shortened component life.

---

**NOTICE**

Care must be taken to ensure that fluids are contained during performance of inspection, maintenance, testing, adjusting and repair of the product. Be prepared to collect the fluid with suitable containers before opening any compartment or disassembling any component containing fluids.

Refer to Special Publication, NENG2500, "Caterpillar Tools and Shop Products Guide" for tools and supplies suitable to collect and contain fluids on Caterpillar products.

Dispose of all fluids according to local regulations and mandates.

---

Engine oil pressure will be high if the engine oil bypass valves become stuck in the closed position and the engine oil flow is restricted. Foreign matter in the engine oil system could be the cause for the restriction of the oil flow and the movement of the engine oil bypass valves. If the engine oil bypass valves are stuck in the closed position, remove each bypass valve and clean each bypass valve in order to correct this problem. You must also clean each bypass valve bore. Install new engine oil filters. New engine oil filters will prevent more debris from causing this problem. For information on the repair of the engine oil filter bypass valve, refer to Disassembly and Assembly, "Engine Oil Filter Base - Disassemble".

---

**NOTICE**

Caterpillar oil filters are built to Caterpillar specifications. Use of an oil filter not recommended by Caterpillar could result in severe engine damage to the engine bearings, crankshaft, etc., as a result of the larger waste particles from unfiltered oil entering the engine lubricating system. Only use oil filters recommended by Caterpillar.

---

i01378651

**Engine Oil Pump - Inspect**

**SMCS Code:** 1304-040

If any part of the engine oil pump is worn enough in order to affect the performance of the engine oil pump, the engine oil pump must be replaced. Refer to the Specifications Module, "Engine Oil Pump" topic for clearances.

i01126690

**Excessive Bearing Wear - Inspect**

**SMCS Code:** 1203-040; 1211-040; 1219-040

When some components of the engine show bearing wear in a short time, the cause can be a restriction in an oil passage.

An engine oil pressure indicator may show that there is enough oil pressure, but a component is worn due to a lack of lubrication. In such a case, look at the passage for the oil supply to the component. A restriction in an oil supply passage will not allow enough lubrication to reach a component. This will result in early wear.

i01282970

**Excessive Engine Oil Consumption - Inspect**

**SMCS Code:** 1348-040

**Oil Leakage On Outside Of Engine**

Check for leakage at the seals at each end of the crankshaft. Look for leakage at the oil pan gasket and all lubrication system connections. Look for any oil that may be leaking from the crankcase breather. This can be caused by combustion gas leakage around the pistons. A dirty crankcase breather will cause high pressure in the crankcase. A dirty crankcase breather will cause the gaskets and the seals to leak.

**Oil Leakage Into Combustion Area Of Cylinders**

Oil leakage into the combustion area of the cylinders can be the cause of blue smoke. There are four possible ways for oil leakage into the combustion area of the cylinders:

- Oil leakage between worn valve guides and valve stems
- Worn components or damaged components (pistons, piston rings, or dirty oil return holes)
- Incorrect installation of the compression ring and/or the intermediate ring
- Oil leakage past the seal rings in the impeller end of the turbocharger shaft

Excessive oil consumption can also be the result if oil with the wrong viscosity is used. Oil with a thin viscosity can be caused by fuel leakage into the crankcase or by increased engine temperature.

i01283115

## Increased Engine Oil Temperature - Inspect

**SMCS Code:** 1348-040

When the engine is at operating temperature and you are using SAE 10W30 oil, the maximum oil temperature is 115 °C (239 °F). This is the temperature of the oil after passing through the oil cooler.

Look for a restriction in the oil passages of the oil cooler. The oil temperature may be higher than normal when the engine is operating. In such a case, the oil cooler may have a restriction. A restriction in the oil cooler will not cause low oil pressure in the engine.

Determine if the oil cooler bypass valve is held in the open position. This condition will allow the oil to pass through the valve instead of the oil cooler. The oil temperature will increase.



# Cooling System

i01389751

## Cooling System - Check (Overheating)

**SMCS Code:** 1350-535

Above normal coolant temperatures can be caused by many conditions. Use the following procedure to determine the cause of above normal coolant temperatures:

### **WARNING**

**Personal injury can result from escaping fluid under pressure.**

**If a pressure indication is shown on the indicator, push the release valve in order to relieve pressure before removing any hose from the radiator.**

1. Check the coolant level in the cooling system. Refer to Operation and Maintenance Manual, "Cooling System Coolant Level - Check". If the coolant level is too low, air will get into the cooling system. Air in the cooling system will cause a reduction in coolant flow and bubbles in the coolant. Air bubbles cause a reduction in the cooling of engine parts.
2. Check the quality of the coolant. The coolant should have the following properties:
  - Color that is similar to new coolant
  - Odor that is similar to new coolant
  - Free from dirt and debris

If the coolant does not have these properties, drain the system and flush the system. Refill the cooling system with the correct mixture of water, antifreeze, and coolant conditioner. Refer to Operation and Maintenance Manual, "General Coolant Information".
3. Check the coolant mixture of antifreeze and water. The mixture should be approximately 50 percent water and 50 percent antifreeze with 3 to 6 percent coolant conditioner. Refer to Operation and Maintenance Manual, "General Coolant Information". If the coolant mixture is incorrect, drain the cooling system and flush the cooling system. Refill the cooling system with the correct mixture of water, antifreeze, and coolant conditioner.

4. Check for air in the cooling system. Air can enter the cooling system in different ways. The following items are some of the most common causes for air in the cooling system:
  - Filling the cooling system incorrectly
  - Combustion gas leakage into the cooling system
  - Loose hose clamp

Combustion gas can get into the system through the following conditions: inside cracks, damaged cylinder head, and damaged cylinder head gasket. A loose hose clamp can allow air into the cooling system during the cooldown period. Air in the cooling system causes a reduction in the cooling capacity of the coolant.

5. Check the fan drive system. A fan drive system that is not turning at the correct speed can cause improper air speed across the radiator core. The lack of proper air flow across the radiator core can cause the coolant not to cool to the proper temperature differential.
6. Check the water temperature gauge. A water temperature gauge which does not work correctly will not show the correct temperature. Refer to Testing and Adjusting, "Cooling System - Test".
7. Check the sending unit. In some conditions, the temperature sensor in the engine sends signals to a sending unit. The sending unit converts these signals to an electrical impulse which is used by a mounted gauge. If the sending unit malfunctions, the gauge can show an incorrect reading. Also if the electric wire breaks or if the electric wire shorts out, the gauge can show an incorrect reading.
8. Check the radiator.
  - a. Check the radiator for a restriction to coolant flow. Check the radiator for debris, for dirt, or for deposits on the inside of the radiator core. Debris, dirt, or deposits will restrict the flow of coolant through the radiator.
  - b. Check for debris or for damage between the fins of the radiator core. Debris between the fins of the radiator core restricts air flow through the radiator core. Refer to Testing and Adjusting, "Cooling System - Inspect".
  - c. Check for missing radiator baffles or for damaged radiator baffles. Radiator baffles prevent recirculation of air around the sides of the radiator. A missing radiator baffle or a damaged radiator baffle raises the temperature of the air that goes through the radiator.

- d. Ensure that the radiator size is according to the OEM specifications. An undersized radiator does not have enough area for the effective release of heat. This may cause the engine to run at a temperature that is higher than normal. The normal temperature is dependent on the ambient temperature.
9. Check the filler cap. A pressure drop in the radiator can cause the boiling point to be lower. This can cause the cooling system to boil. Refer to Testing and Adjusting, "Cooling System - Test".
  10. Check the fan and/or the fan shroud.
    - a. Ensure that the fan is installed correctly. Improper installation of the fan can cause engine overheating.
    - b. The fan must be large enough to send air through most of the area of the radiator core. Ensure that the size of the fan and the position of the fan are according to the OEM specifications.
    - c. The fan shroud and the radiator baffling must be the proper size. The fan shroud and the radiator baffling must be positioned correctly. The size of the fan shroud and the position of the fan shroud should meet the OEM specifications. The size of the radiator baffling and the position of the radiator baffling should meet the OEM specifications.
  11. Check for loose drive belts.
    - a. A loose fan drive belt will cause a reduction in the air flow across the radiator. Check the fan drive belt for proper belt tension. Adjust the tension of the fan drive belt, if necessary. Refer to Operation and Maintenance Manual, "Belt - Inspect".
    - b. A loose water pump drive belt will cause a reduction in coolant flow through the radiator. Check the water pump drive belt for proper belt tension. Adjust the tension of the water pump drive belt, if necessary. Refer to Operation and Maintenance Manual, "Belt - Inspect".
  12. Check the cooling system hoses and clamps. Damaged hoses with leaks can normally be seen. Hoses that have no visual leaks can soften during operation. The soft areas of the hose can become kinked or crushed during operation. These areas of the hose can cause a restriction in the coolant flow. Hoses can become soft. Also, hoses can get cracks after a period of time. The inside of a hose can deteriorate, and the loose particles of the hose can cause a restriction of the coolant flow. Refer to Operation and Maintenance Manual, "Hoses and Clamps - Inspect/Replace".
  13. Check for a restriction in the air inlet system. A restriction of the air that is coming into the engine can cause high cylinder temperatures. High cylinder temperatures can cause higher than normal temperatures in the cooling system. Refer to Testing and Adjusting, "Air Inlet and Exhaust System - Inspect".
    - a. If the measured restriction is higher than the maximum permissible restriction, remove the foreign material from the engine air cleaner element or install a new engine air cleaner element. Refer to Operation and Maintenance Manual, "Engine Air Cleaner Element - Clean/Replace".
    - b. Check the air inlet system for a restriction again.
    - c. If the measured restriction is still higher than the maximum permissible restriction, check the air inlet piping for a restriction.
  14. Check for a restriction in the exhaust system. A restriction of the air that is coming out of the engine can cause high cylinder temperatures.
    - a. Make a visual inspection of the exhaust system. Check for damage to exhaust piping. Also, check for a damaged muffler. If no damage is found, check the exhaust system for a restriction. Refer to Testing and Adjusting, "Air Inlet and Exhaust System - Inspect".
    - b. If the measured restriction is higher than the maximum permissible restriction, there is a restriction in the exhaust system. Repair the exhaust system, as required.
    - c. Ensure that the exhaust gas is not being drawn into the cooling air inlet.

i02209912

15. Check the shunt line. The shunt line must be submerged in the expansion tank. A restriction of the shunt line from the radiator top tank to the engine water pump inlet will cause a reduction in water pump efficiency. A reduction in water pump efficiency will result in low coolant flow and overheating.
16. Check the water temperature regulator. A water temperature regulator that does not open, or a water temperature regulator that only opens part of the way can cause overheating. Refer to Testing and Adjusting, "Water Temperature Regulator - Test".
17. Check the water pump. A water pump with a damaged impeller does not pump enough coolant for correct engine cooling. Remove the water pump and check for damage to the impeller. Refer to Testing and Adjusting, "Water Pump - Test".
18. Check the air flow through the engine compartment. The air flow through the radiator comes out of the engine compartment. Ensure that the filters, the air conditioner, and similar items are not installed in a way that prevents the free flow of air through the engine compartment.
19. Check the aftercooler. A restriction of air flow through the air to air aftercooler (if equipped) can cause overheating. Check for debris or deposits which would prevent the free flow of air through the aftercooler. Refer to Testing and Adjusting, "Aftercooler - Test".
20. Consider high outside temperatures. When outside temperatures are too high for the rating of the cooling system, there is not enough of a temperature difference between the outside air and coolant temperatures.
21. Consider high altitude operation. The cooling capacity of the cooling system goes down as the engine is operated at higher altitudes. A pressurized cooling system that is large enough to keep the coolant from boiling must be used.
22. The engine may be running in the lug condition. When the load that is applied to the engine is too large, the engine will run in the lug condition. When the engine is running in the lug condition, engine rpm does not increase with an increase of fuel. This lower engine rpm causes a reduction in air flow through the radiator. This lower engine rpm also causes a reduction in coolant flow through the system. This combination of less air and less coolant flow during high input of fuel will cause above normal heating.

## Cooling System - Inspect

**SMCS Code:** 1350-040

Cooling systems that are not regularly inspected are the cause for increased engine temperatures. Make a visual inspection of the cooling system before any tests are performed.

### **WARNING**

**Personal injury can result from escaping fluid under pressure.**

**If a pressure indication is shown on the indicator, push the release valve in order to relieve pressure before removing any hose from the radiator.**

1. Check the coolant level in the cooling system. Refer to Operation and Maintenance Manual, "Cooling System Coolant Level - Check".
2. Check the quality of the coolant. The coolant should have the following properties:

- Color that is similar to new coolant
- Odor that is similar to new coolant
- Free from dirt and debris

If the coolant does not have these properties, drain the system and flush the system. Refill the cooling system with the correct mixture of water, antifreeze, and coolant conditioner. Refer to the Operation and Maintenance Manual for your engine in order to obtain coolant recommendations.

3. Look for leaks in the system.

**Note:** A small amount of coolant leakage across the surface of the water pump seals is normal. This leakage is required in order to provide lubrication for this type of seal. A hole is provided in the water pump housing in order to allow this coolant/seal lubricant to drain from the pump housing. Intermittent leakage of small amounts of coolant from this hole is not an indication of water pump seal failure.

4. Ensure that the airflow through the radiator does not have a restriction. Look for bent core fins between the folded cores of the radiator. Also, look for debris between the folded cores of the radiator.
5. Inspect the drive belts for the fan.
6. Check for damage to the fan blades.

7. Look for air or combustion gas in the cooling system.
8. Inspect the filler cap, and check the surface that seals the filler cap. This surface must be clean.

i02281020

## Cooling System - Test

**SMCS Code:** 1350-040; 1350-081

This engine has a pressure type cooling system. A pressure type cooling system has two advantages. The cooling system can be operated in a safe manner at a temperature higher than the normal boiling point (steam) of water.

This type of system prevents cavitation in the water pump. Cavitation is the forming of low pressure bubbles in liquids that are caused by mechanical forces. The formation of an air pocket or a steam pocket in this type of cooling system is difficult.

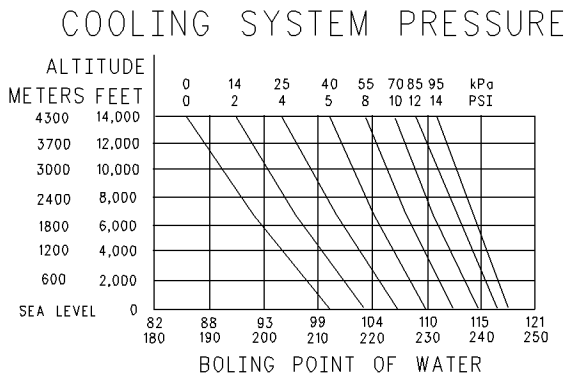

Illustration 68

g00921815

Boiling point of water

Remember that temperature and pressure work together. When a diagnosis is made of a cooling system problem, temperature and pressure must be checked. Cooling system pressure will have an effect on the cooling system temperature. For an example, refer to Illustration 68. This will show the effect of pressure on the boiling point (steam) of water. This will also show the effect of height above sea level.

### WARNING

**Personal injury can result from hot coolant, steam and alkali.**

**At operating temperature, engine coolant is hot and under pressure. The radiator and all lines to heaters or the engine contain hot coolant or steam. Any contact can cause severe burns.**

**Remove filler cap slowly to relieve pressure only when engine is stopped and radiator cap is cool enough to touch with your bare hand.**

**Cooling System Conditioner contains alkali. Avoid contact with skin and eyes.**

The coolant level must be to the correct level in order to check the coolant system. The engine must be cold and the engine must not be running.

After the engine is cool, loosen the pressure cap in order to relieve the pressure out of the cooling system. Then remove the pressure cap.

The level of the coolant should not be more than 13 mm (0.5 inch) from the bottom of the filler pipe. If the cooling system is equipped with a sight glass, the coolant should be to the proper level in the sight glass.

## Test Tools For Cooling System

Table 16

Tools Needed		
Part Number	Part Name	Quantity
4C - 6500	Digital Thermometer	1
8T - 2700	Blowby/Air Flow Indicator	1
9S - 8140	Pressurizing Pump	1
9U - 7400 or 1U - 6602	Multitach Tool Group or Photo-Tachometer	1
245 - 5829	Coolant/Battery Tester Gp	1

### WARNING

**Making contact with a running engine can cause burns from hot parts and can cause injury from rotating parts.**

**When working on an engine that is running, avoid contact with hot parts and rotating parts.**



Illustration 69

g00876179

## 4C - 6500 Digital Thermometer

The 4C - 6500 Digital Thermometer is used in the diagnosis of overheating conditions and in the diagnosis of overcooling conditions. This group can be used to check temperatures in several different parts of the cooling system. Refer to the tool's Operating Manual for the testing procedure.

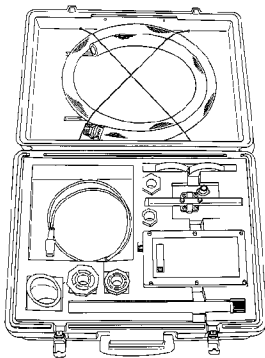

Illustration 70

g00286269

## 8T - 2700 Blowby/Air Flow Indicator

The 8T - 2700 Blowby/Air Flow Indicator is used to check the air flow through the radiator core. Refer to Special Instruction, SEHS8712, "Using the 8T - 2700 Blowby/Air Flow Indicator" for the test procedure for checking blowby.

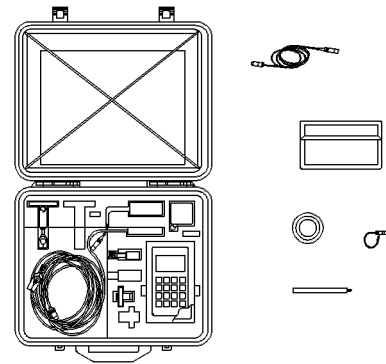

Illustration 71

g00286276

## 9U - 7400 Multitach Tool Group

The 9U - 7400 Multitach Tool Group is used to check the fan speed. Refer to Operating Manual, NEHS0605, "9U - 7400 Multitach Tool Group" for the testing procedure.

The 9U - 7400 Multitach Tool Group can measure engine rpm from a magnetic pickup. This magnetic pickup is located in the flywheel housing. The magnetic pickup also uses the ability to measure engine rpm from visual engine parts that are rotating.

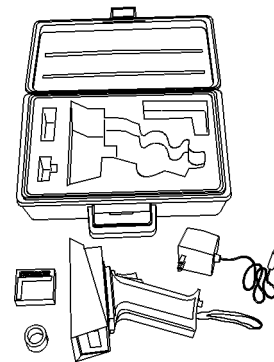

Illustration 72

g00296064

## 1U - 6602 Photo-Tachometer

The 1U - 6602 Photo-Tachometer is a photo-tachometer that is held by hand for general use. The 1U - 6602 Photo-Tachometer is a phototach, so this tachometer only registers basic input frequency on any visible, rotating part. The basic input frequency equals one revolution per a piece of reflective tape. The 1U - 6602 Photo-Tachometer does not replace the 9U - 7400 Multitach Tool Group.

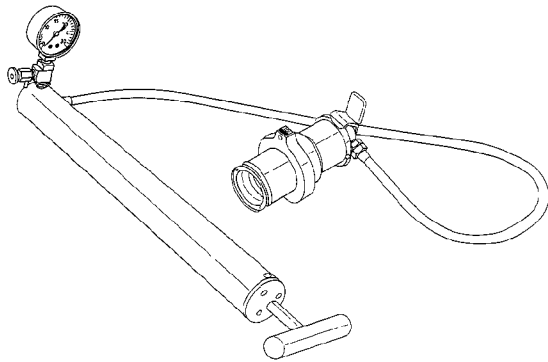

Illustration 73 g00286369  
9S-8140 Pressurizing Pump

The 9S-8140 Pressurizing Pump is used to test the filler caps. This pressurizing pump is also used to pressure test the cooling system for leaks.

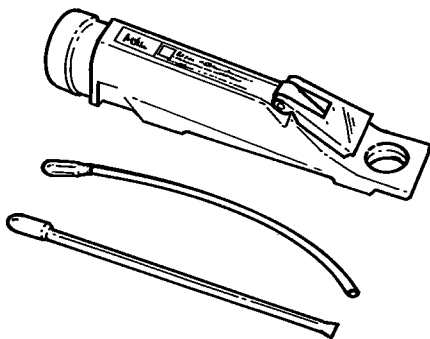

Illustration 74 g00439083  
245-5829 Coolant/Battery Tester Gp

Check the coolant frequently in cold weather for the proper glycol concentration. Use the 245-5829 Coolant/Battery Tester Gp in order to ensure adequate freeze protection. The tester gives immediate, accurate readings. The tester can be used for antifreeze/coolants that contain ethylene or propylene glycol.

## Making the Correct Antifreeze Mixtures

Refer to the Operation and Maintenance Manual for the correct coolant recommendations for your individual application.

## Checking the Filler Cap

Table 17

Tools Needed		
Part Number	Part Name	Quantity
9S-8140	Pressurizing Pump	1

One cause for a pressure loss in the cooling system can be a damaged seal on the radiator filler cap.

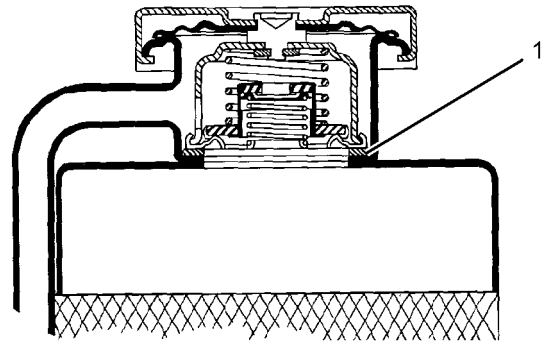

Illustration 75 g01096114

Typical schematic of filler cap

(1) Sealing surface of both filler cap and radiator

### **WARNING**

**Personal injury can result from hot coolant, steam and alkali.**

**At operating temperature, engine coolant is hot and under pressure. The radiator and all lines to heaters or the engine contain hot coolant or steam. Any contact can cause severe burns.**

**Remove filler cap slowly to relieve pressure only when engine is stopped and radiator cap is cool enough to touch with your bare hand.**

**Cooling System Conditioner contains alkali. Avoid contact with skin and eyes.**

To check for the amount of pressure that opens the filler cap, use the following procedure:

1. After the engine cools, carefully loosen the filler cap. Slowly release the pressure from the cooling system. Then, remove the filler cap.

Carefully inspect the filler cap. Look for any damage to the seals and to the sealing surface. Inspect the following components for any foreign substances:

- Filler cap
- Seal
- Surface for seal

Remove any deposits that are found on these items, and remove any material that is found on these items.

2. Install the filler cap on the 9S-8140 Pressurizing Pump.
3. Look at the gauge for the exact pressure that opens the filler cap.
4. Compare the gauge's reading with the opening pressure that is listed on the filler cap.
5. If the filler cap is damaged, replace the filler cap.

## Testing The Radiator And Cooling System For Leaks

Table 18

Tools Needed		
Part Number	Part Name	Quantity
9S-8140	Pressurizing Pump	1

Use the following procedure in order to check the cooling system for leaks:

### WARNING

Personal injury can result from hot coolant, steam and alkali.

At operating temperature, engine coolant is hot and under pressure. The radiator and all lines to heaters or the engine contain hot coolant or steam. Any contact can cause severe burns.

Remove filler cap slowly to relieve pressure only when engine is stopped and radiator cap is cool enough to touch with your bare hand.

Cooling System Conditioner contains alkali. Avoid contact with skin and eyes.

1. After the engine is cool, loosen the filler cap slowly and allow pressure out of the cooling system. Then remove the filler cap from the radiator.
2. Ensure that the coolant level is above the top of the radiator core.
3. Install the 9S-8140 Pressurizing Pump onto the radiator.

4. Take the pressure reading on the gauge to 20 kPa (3 psi) more than the pressure on the filler cap.
5. Check the radiator for leakage on the outside.
6. Check all connection points for leakage, and check the hoses for leakage.

The cooling system does not have leakage only if the following conditions exist:

- You do not observe any outside leakage.
- The reading remains steady after five minutes.

The inside of the cooling system has leakage only if the following conditions exist:

- The reading on the gauge goes down.
- You do not observe any outside leakage.

Make any repairs, as required.

## Test For The Water Temperature Gauge

Table 19

Tools Needed		
Part Number	Part Name	Quantity
4C-6500 or 2F-7112	Digital Thermometer or Thermometer	1

### WARNING

Personal injury can result from escaping fluid under pressure.

If a pressure indication is shown on the indicator, push the release valve in order to relieve pressure before removing any hose from the radiator.

### WARNING

Making contact with a running engine can cause burns from hot parts and can cause injury from rotating parts.

When working on an engine that is running, avoid contact with hot parts and rotating parts.

Check the accuracy of the water temperature indicator or water temperature sensor if you find either of the following conditions:

i01666401

- The engine runs at a temperature that is too hot, but a normal temperature is indicated. A loss of coolant is found.
- The engine runs at a normal temperature, but a hot temperature is indicated. No loss of coolant is found.

Caterpillar Electronic Technician (ET) can also be used to read the coolant temperature of the engine.

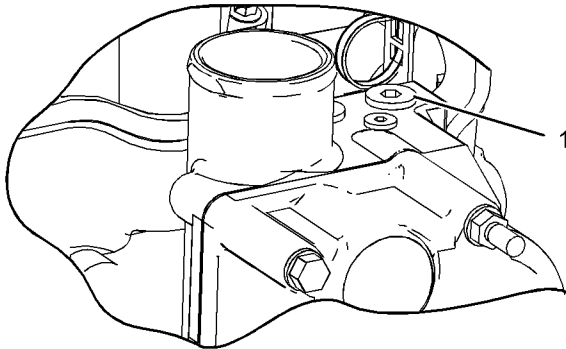

Illustration 76

g01141597

Test location

(1) Plug

Remove the plug (1) from one of ports in the water manifold. Install one of the following thermometers in the open port:

- The 4C-6500 Digital Thermometer
- The 2F-7112 Thermometer

A temperature indicator of known accuracy can also be used to make this check.

Start the engine. Run the engine until the temperature reaches the desired range according to the test thermometer. If necessary, place a cover over part of the radiator in order to cause a restriction of the air flow. The reading on the water temperature indicator should agree with the test thermometer within the tolerance range of the water temperature indicator.

## Water Temperature Regulator - Test

SMCS Code: 1355-081; 1355-081-ON

### **WARNING**

**Personal injury can result from escaping fluid under pressure.**

**If a pressure indication is shown on the indicator, push the release valve in order to relieve pressure before removing any hose from the radiator.**

1. Remove the water temperature regulator from the engine.
2. Heat water in a pan until the temperature of the water is equal to the fully open temperature of the water temperature regulator. Refer to Specifications, "Water Temperature Regulator" for the fully open temperature of the water temperature regulator. Stir the water in the pan. This will distribute the temperature throughout the pan.
3. Hang the water temperature regulator in the pan of water. The water temperature regulator must be below the surface of the water. The water temperature regulator must be away from the sides and the bottom of the pan.
4. Keep the water at the correct temperature for ten minutes.
5. After ten minutes, remove the water temperature regulator. Immediately measure the opening of the water temperature regulator. Refer to Specifications, "Water Temperature Regulator" for the minimum opening distance of the water temperature regulator at the fully open temperature.

If the distance is less than the amount listed in the manual, replace the water temperature regulator.



i01849228

## Water Pump - Test

SMCS Code: 1361-081

Table 20

Required Tools		
Part Number	Part Name	Quantity
6V - 7775	Air Pressure Gauge	1
8J - 7844	Adapter Fitting	1
3K - 0360	O-Ring Seal	1
5P - 2725	Probe Seal Adapter	1
164 - 2192	Pressure Probe <sup>(1)</sup>	1
5P - 4487	Adapter	1
5P - 2720	Probe Adapter	1

(1) If port (1) is used, two tools are required.

To measure the pressure rise, compare inlet pressure with outlet pressure. Calculate the difference between the pressure of the inlet port and the outlet ports. The pressure rise must add up to a minimum of 80 kPa (12 psi) under both of the following conditions:

- The engine is at operating temperature.
- The engine operates at full load condition.

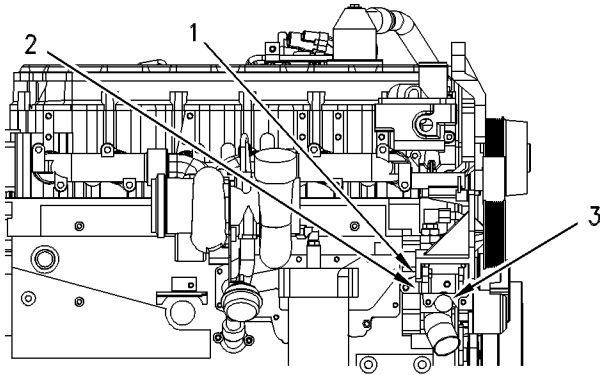

Illustration 77

g00296313

Pressure test ports for the water pump (Typical example)

- (1) Port (alternate heater supply)
- (2) Port (engine diagnosis)
- (3) Port (heater return line)

### WARNING

**Making contact with a running engine can cause burns from hot parts and can cause injury from rotating parts.**

**When working on an engine that is running, avoid contact with hot parts and rotating parts.**

The pressure rise is the difference between inlet pressure and outlet pressure. The pressure rise indicates if the water pump operates correctly. Port (1) and Port (2) represent the water pump outlet pressure. Port (3) represents the water pump inlet pressure.

## Basic Engine

i01432013

### Piston Ring Groove - Inspect

**SMCS Code:** 1214-040

The 186-0190 Piston Ring Groove Gauge Gp is available to check the top ring groove in the piston. Refer to the instruction card with the tool for the correct use of the 186-0190 Piston Ring Groove Gauge Gp.

i01284815

### Connecting Rod Bearings - Inspect

**SMCS Code:** 1219-040

The connecting rod bearings fit tightly in the bore in the rod. If the bearing joints are fretted, check the bore size. This can be an indication of wear because of a loose fit.

Connecting rod bearings are available with 0.25 mm (0.010 inch) and 0.50 mm (0.020 inch) smaller inside diameter than the original size bearings. These bearings are for crankshafts that have been ground.

i01284843

### Main Bearings - Inspect

**SMCS Code:** 1203-040

Main bearings are available with 0.25 mm (0.010 inch) and a 0.50 mm (0.020 inch) smaller inside diameter than the original size bearings. These bearings are for crankshafts that have been ground.

Main bearings are also available with a larger outside diameter than the original size bearings. These bearings are used for the cylinder blocks with the main bearing bore that is made larger than the bore's original size. The size that is available has a 0.50 mm (0.020 inch) outside diameter that is larger than the original size bearings.

Refer to Special Instruction, SMHS7606, "Use of 1P-4000 Line Boring Tool Group" for the instructions that are needed to use the 1P-4000 Line Boring Tool Group. The 1P-4000 Line Boring Tool Group is used in order to check the alignment of the main bearing bores. The 1P-3537 Dial Bore Gauge Group can be used to check the size of the bore. Refer to Special Instruction, GMG00981, "1P-3537 Dial Bore Gauge Group" for the instructions that are needed to use the 1P-3537 Dial Bore Gauge Group.

i02487145

### Cylinder Block - Inspect

**SMCS Code:** 1201-040

Table 21

Required Tools		
Part Number	Part Name	Quantity
1P-3537	Dial Bore Gauge Group	1

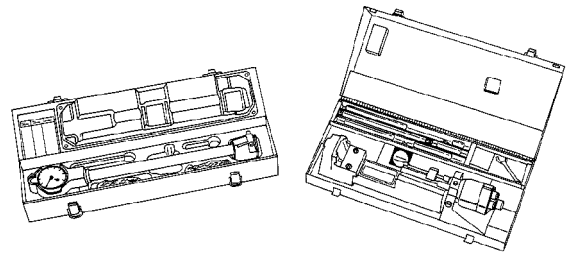

Illustration 78

g00285686

1P-3537 Dial Bore Gauge Group

If the main bearing caps are installed without bearings, the bore in the block for the main bearings can be checked. Tighten the nuts on the bearing caps to the torque that is given in Specifications, "Cylinder Block". Alignment error in the bores must not be more than 0.08 mm (0.003 inch).

The 1P-3537 Dial Bore Gauge Group can be used to check the size of the bore.

i02281052

## Flywheel - Inspect

SMCS Code: 1156-040

Table 22

Tools Needed		
Part Number	Part Name	Quantity
8T-5096	Dial Indicator Gp	1

## Face Runout (axial eccentricity) of the Flywheel

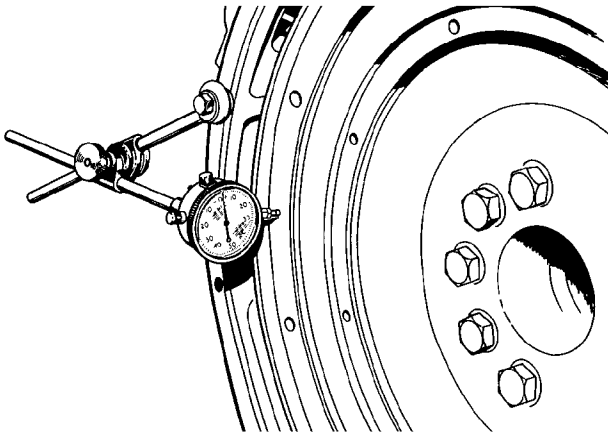

Illustration 79

g00286049

Checking face runout of the flywheel

1. Refer to Illustration 79 and install the dial indicator. Always put a force on the crankshaft in the same direction before the dial indicator is read. This will remove any crankshaft end clearance.
2. Set the dial indicator to read 0.0 mm (0.00 inch).
3. Turn the flywheel at intervals of 90 degrees and read the dial indicator.
4. Take the measurements at all four points. The difference between the lower measurements and the higher measurements that are performed at all four points must not be more than 0.15 mm (0.006 inch), which is the maximum permissible face runout (axial eccentricity) of the flywheel.

## Bore Runout (radial eccentricity) of the Flywheel

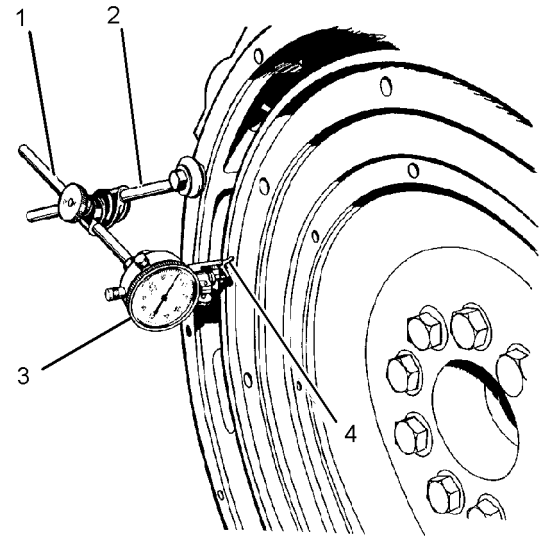

Illustration 80

g01141609

Checking bore runout of the flywheel

- (1) 7H-1945 Holding Rod
  - (2) 7H-1645 Holding Rod
  - (3) 7H-1942 Dial Indicator
  - (4) 7H-1940 Universal Attachment
1. Install 7H-1942 Dial Indicator (3). Make an adjustment of 7H-1940 Universal Attachment (4) so the dial indicator makes contact on the flywheel.
  2. Set the dial indicator to read 0.0 mm (0.00 inch).
  3. Turn the flywheel at intervals of 90 degrees and read the dial indicator.
  4. Take the measurements at all four points. The difference between the lower measurements and the higher measurements that are performed at all four points must not be more than 0.15 mm (0.006 inch), which is the maximum permissible face runout (radial eccentricity) of the flywheel.

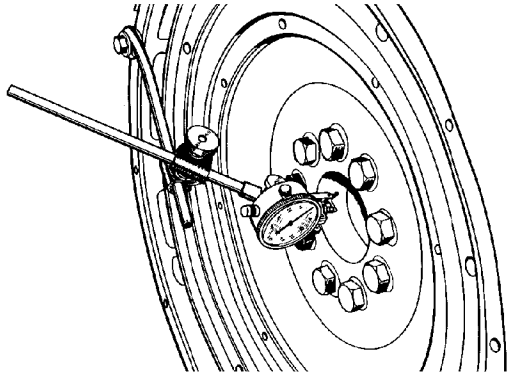

Illustration 81 g00286058  
Flywheel clutch pilot bearing bore

5. To find the runout (eccentricity) of the pilot bearing bore, use the preceding procedure.
6. The runout (eccentricity) of the bore for the pilot bearing in the flywheel must not exceed 0.13 mm (0.005 inch).

i02281054

## Flywheel Housing - Inspect

**SMCS Code:** 1157-040

Table 23

Tools Needed		
Part Number	Part Name	Quantity
8T-5096	Dial Indicator Gp	1

### Face Runout (Axial Eccentricity) of the Flywheel Housing

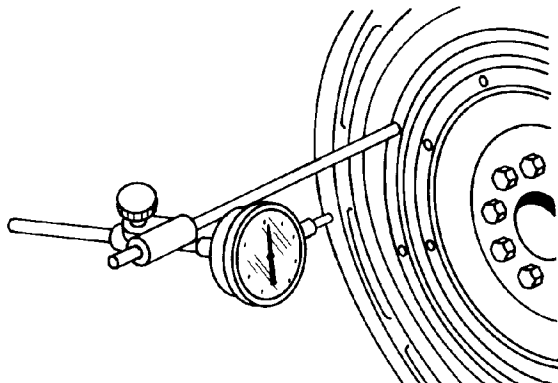

Illustration 82 g00285931  
8T-5096 Dial Indicator

If you use any other method except the method that is given here, always remember that the bearing clearance must be removed in order to receive the correct measurements.

1. Fasten a dial indicator to the flywheel so the anvil of the dial indicator will contact the face of the flywheel housing.
2. Put a force on the crankshaft toward the rear before the dial indicator is read at each point.

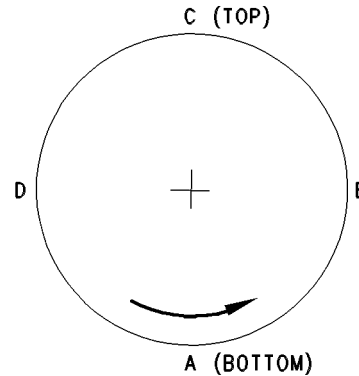

Illustration 83 g00285932  
Checking face runout of the flywheel housing

3. Turn the flywheel while the dial indicator is set at 0.0 mm (0.00 inch) at location (A). Read the dial indicator at locations (B), (C) and (D).
4. The difference between the lower measurements and the higher measurements that are performed at all four points must not be more than 0.30 mm (0.012 inch), which is the maximum permissible face runout (axial eccentricity) of the flywheel housing.

### Bore Runout (Radial Eccentricity) of the Flywheel Housing

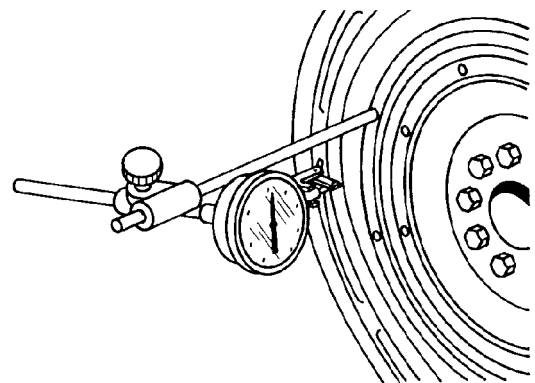

Illustration 84 g00285934  
8T-5096 Dial Indicator

1. Fasten a dial indicator to the flywheel so the anvil of the dial indicator will contact the bore of the flywheel housing.

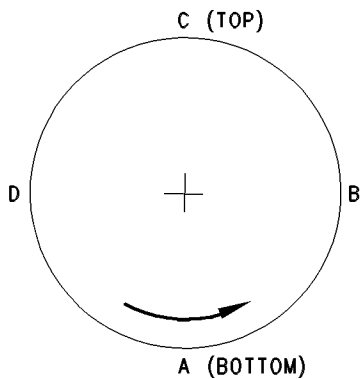

Illustration 85 g00285932  
Checking bore runout of the flywheel housing

CHART FOR DIAL INDICATOR MEASUREMENTS					
	Position of dial indicator				
	Line No.	A	B	C	D
Correction for bearing clearance	I	0			
Dial Indicator Reading	II	0			
Total of Line 1 & 2	III	0	**	*	**
*Total Vertical eccentricity (out of round). **Subtract the smaller No. from the larger No. The difference is the total horizontal eccentricity.					

Illustration 86 g00285936

2. While the dial indicator is in the position at location (C) adjust the dial indicator to 0.0 mm (0.00 inch). Push the crankshaft upward against the top of the bearing. Refer to Illustration 86. Write the measurement for bearing clearance on line 1 in column (C).

**Note:** Write the measurements for the dial indicator with the correct notations. This notation is necessary for making the calculations in the chart correctly.

3. Divide the measurement from Step 2 by two. Write this number on line 1 in columns (B) and (D).
4. Turn the flywheel in order to put the dial indicator at position (A). Adjust the dial indicator to 0.0 mm (0.00 inch).
5. Turn the flywheel counterclockwise in order to put the dial indicator at position (B). Write the measurements in the chart.
6. Turn the flywheel counterclockwise in order to put the dial indicator at position (C). Write the measurement in the chart.

7. Turn the flywheel counterclockwise in order to put the dial indicator at position (D). Write the measurement in the chart.

8. Add the lines together in each column.

9. Subtract the smaller number from the larger number in column B and column D. Place this number on line III. The result is the horizontal eccentricity (out of round). Line III in column C is the vertical eccentricity.

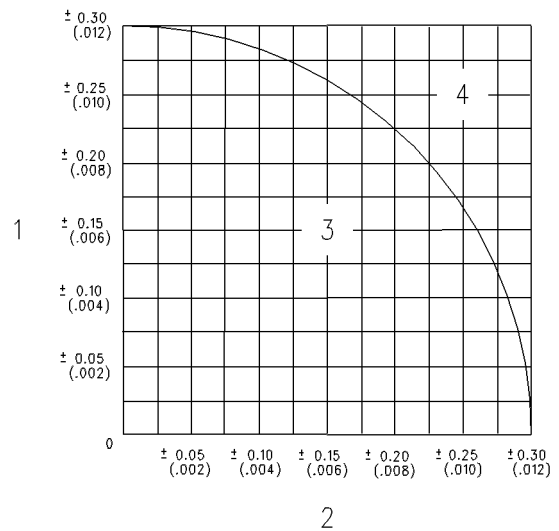

Illustration 87 g00286046

Graph for total eccentricity

- (1) Total vertical eccentricity
- (2) Total horizontal eccentricity
- (3) Acceptable value
- (4) Unacceptable value

10. Find the intersection of the eccentricity lines (vertical and horizontal) in Illustration 87.

11. If the point of the intersection is in the ACCEPTABLE range, the bore is in alignment. If the point of intersection is in the NOT ACCEPTABLE range, the flywheel housing must be changed.

i02487784

## Vibration Damper - Check

SMCS Code: 1205-535

### Rubber Vibration Damper (If Equipped)

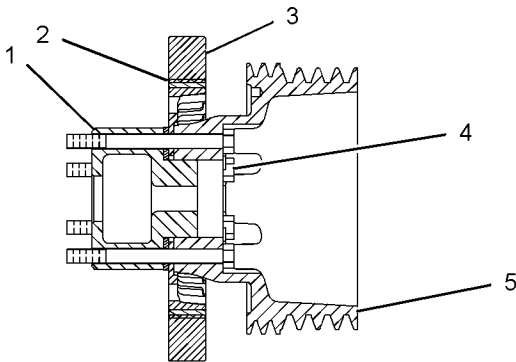

Illustration 88

g01124289

Vibration damper and pulley

- (1) Adapter
- (2) Rubber
- (3) Damper assembly
- (4) Bolt
- (5) Crankshaft pulley

The vibration damper is installed on the front of crankshaft. The space in the damper assembly (3) is filled with rubber (2). The vibration damper limits the torsional vibration.

Replace the damper if any of the following conditions exist:

- The damper is dented or cracked.
- The paint on the damper is discolored from heat.
- There is a large amount of gear train wear that is not caused by lack of oil.
- Analysis of the oil has revealed that the front main bearing is badly worn.
- The engine has had a failure because of a broken crankshaft.

### Viscous Vibration Damper (If Equipped)

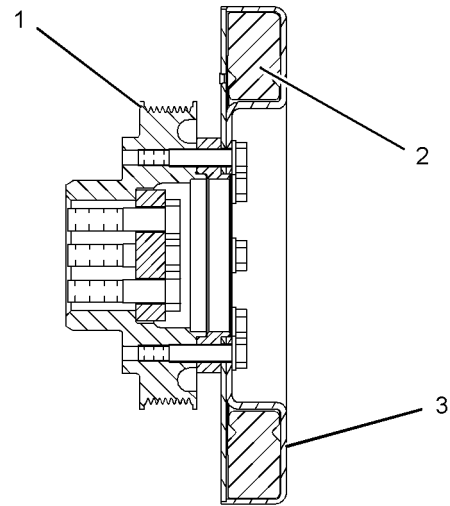

Illustration 89

g01124414

Viscous vibration damper

- (1) Pulley
- (2) Weight
- (3) Case

Damage to the vibration damper or failure of the vibration damper will increase vibrations. This will result in damage to the crankshaft.

Replace the damper if any of the following conditions exist:

- The damper is dented, cracked, or fluid is leaking from the damper.
- The paint on the damper is discolored from excessive heat.
- The damper is bent.
- The bolt holes are worn or there is a loose fit for the bolts.
- The engine has had a crankshaft failure due to torsional forces.

#### NOTICE

Inspect the viscous vibration damper for signs of leaking and for signs of damage to the case. Either of these conditions can cause the weight to contact the case. This contact can affect damper operation.

i01388616

## Vibration Damper - Check

SMCS Code: 1205-535

S/N: G3E1-Up

### Rubber Vibration Damper (If Equipped)

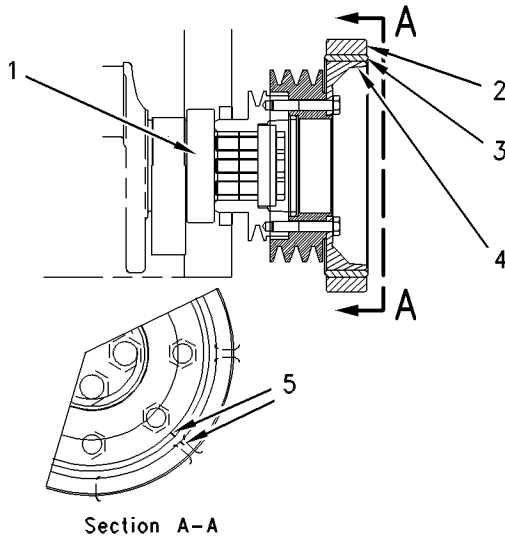

Illustration 90

g00295949

Rubber vibration damper

- (1) Crankshaft
- (2) Hub
- (3) Rubber
- (4) Ring
- (5) Alignment marks

Damage to the vibration damper or failure of the vibration damper will increase vibrations. This will result in damage to the crankshaft.

If any of the following problems with the rubber vibration damper exist, replace the rubber vibration damper:

- Damaged
- Bent
- Worn bolt holes with loose fit for bolts
- Crankshaft failure due to torsional forces

The rubber vibration damper displays alignment marks on the hub and on the ring. These marks indicate the condition of the rubber vibration damper.

If the alignment marks are not aligned, the rubber portion of the rubber vibration damper has separated from the hub and/or from the ring. When the alignment marks are not aligned, replace the rubber vibration damper.

A used rubber vibration damper can have a visual wobble of the outer ring. When the vibration damper rotates, this wobble consists of movement from the front to the rear. This does not call for a replacement, because some wobble of the outer ring is typical. Use the following procedure to make sure that the wobble of the outer ring is acceptable:

1. Install a dial indicator, a contact point, or other parts that are required to hold the dial indication stationary.
- Note:** The contact point must be perpendicular (90 degree angle) to the face of the outer ring of the rubber vibration damper. The contact point must make contact near to the center of the outer ring.
2. Push on the front end of the crankshaft in order to prevent any end play. End play would be free movement on the centerline. You must keep pressure on the crankshaft, until you complete the measurements.
  3. Set the dial indicator to a reading of 0.0 mm (0.00 inch).
  4. Turn the crankshaft by 360 degrees and watch the dial indicator. A total indicator reading of 0.00 to 2.03 mm (0.000 to 0.080 inch) is acceptable.

## Viscous Vibration Damper

---

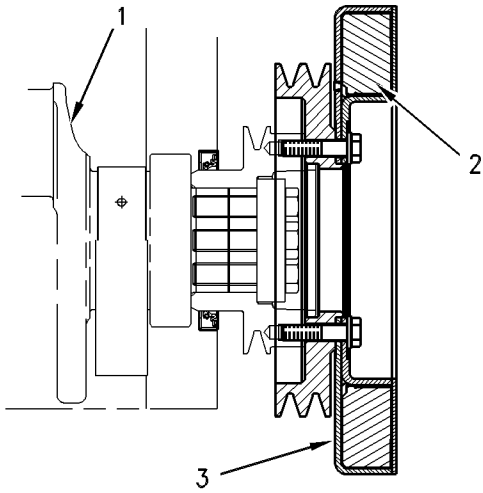

Illustration 91

g00295962

### Viscous Vibration Damper

- (1) Crankshaft
- (2) Weight
- (3) Case

Damage to the vibration damper or failure of the vibration damper will increase vibrations. This will result in damage to the crankshaft.

If any of the following problems with the viscous vibration damper exist, replace the viscous vibration damper:

- Leaking
- Damaged
- Bent
- Worn bolt holes with loose fit for bolts
- Crankshaft failure due to torsional forces

---

### NOTICE

Inspect the viscous vibration damper for signs of leaking and for signs of damage to the case. Either of these conditions can cause the weight to contact the case. This contact can affect damper operation.

---



# Electrical System

i02482495

## Battery - Test

SMCS Code: 1401-081

Most of the tests of the electrical system can be done on the engine. The wiring insulation must be in good condition. The wire and cable connections must be clean, and both components must be tight.

### WARNING

Never disconnect any charging unit circuit or battery circuit cable from the battery when the charging unit is operated. A spark can cause an explosion from the flammable vapor mixture of hydrogen and oxygen that is released from the electrolyte through the battery outlets. Injury to personnel can be the result.

The battery circuit is an electrical load on the charging unit. The load is variable because of the condition of the charge in the battery.

### NOTICE

The charging unit will be damaged if the connections between the battery and the charging unit are broken while the battery is being charged. Damage occurs because the load from the battery is lost and because there is an increase in charging voltage. High voltage will damage the charging unit, the regulator, and other electrical components.

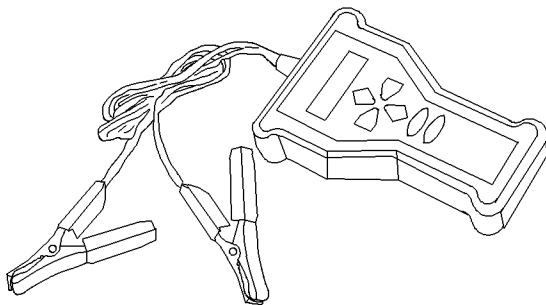

Illustration 92  
177-2330 Battery Analyzer

g00859857

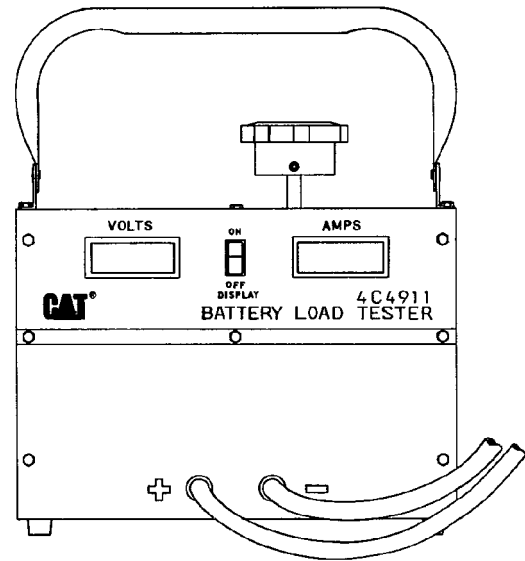

Illustration 93  
4C-4911 Battery Load Tester

g00283565

Use the 4C-4911 Battery Load Tester or the 177-2330 Battery Analyzer in order to test a battery that does not maintain a charge when the battery is active. The 4C-4911 Battery Load Tester and the 177-2330 Battery Analyzer are portable units. The 4C-4911 Battery Load Tester or the 177-2330 Battery Analyzer can be used under field conditions and under high temperatures. The tester can be used to load test all 6, 8, and 12 Volt batteries. This tester has two heavy-duty load cables that can easily be fastened to the battery terminals. A load adjustment knob is located on the top of the tester. The load adjustment knob permits the current that is being drawn from the battery to be adjusted to a maximum of 1000 amperes. The tester is cooled by an internal fan that is automatically activated when a load is applied.

The tester has a built-in LCD. The LCD is a digital voltmeter. The LCD is a digital meter that will also display the amperage. The digital voltmeter accurately measures the battery voltage at the battery through wires for tracing. These wires are buried inside the load cables. The digital meter, that displays the amperage, accurately displays the current that is being drawn from the battery which is being tested.

**Note:** Refer to Operating Manual, SEHS9249, "Use of 4C-4911 Battery Load Tester for 6, 8, and 12 Volt Lead Acid Batteries" for detailed instruction on the use of the 4C-4911 Battery Load Tester. Refer to Operating Manual, NEHS0764, "Using the 177-2330 Battery Analyzer" for detailed instruction on the use of the 177-2330 Battery Analyzer. See Special Instruction, SEHS7633, "Battery Test Procedure" for the correct procedures to use when you test the battery. This publication also contains the specifications to use when you test the battery.

i02482986

## Charging System - Test

**SMCS Code:** 1406-081

The condition of charge in the battery at each regular inspection will show if the charging system is operating correctly. An adjustment is necessary when the battery is constantly in a low condition of charge or a large amount of water is needed. A large amount of water would be more than one ounce of water per a cell per a week or per every 100 service hours.

When it is possible, make a test of the charging unit and voltage regulator on the engine, and use wiring and components that are a permanent part of the system. Off-engine testing or bench testing will give a test of the charging unit and voltage regulator operation. This testing will give an indication of needed repair. After repairs are made, perform a test in order to prove that the units have been repaired to the original condition of operation.

See Special Instruction, REHS0354, "Charging System Troubleshooting" for the correct procedures to use to test the charging system. This publication also contains the specifications to use when you test the charging system.

## Test Tools For The Charging System

Table 24

Tools Needed		
Part Number	Part Name	Quantity
225 - 8266	Ammeter Tool Gp	1
237 - 5130 or 146 - 4080	Digital Multimeter Gp or Digital Multimeter Gp	1

## 225 - 8266 Ammeter Tool Gp

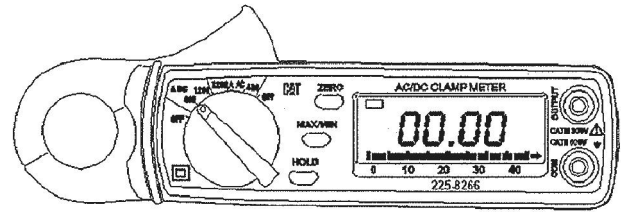

Illustration 94

g01012117

225 - 8266 Ammeter Tool Gp

The 225 - 8266 Ammeter Tool Gp is completely portable. This ammeter is a self-contained instrument that measures electrical currents without breaking the circuit and without disturbing the conductor's insulation.

The ammeter contains a digital display that is used to monitor current directly within a range between 1 ampere and 1200 amperes. If an optional 6V - 6014 Cable is connected between this ammeter and a digital multimeter, current readings can be viewed directly from the display of the multimeter. The multimeter should be used under only one condition:

- the readings are less than 1 ampere.

A lever opens the ammeter's jaws over a conductor. The conductor's diameter can not be larger than 19 mm (0.75 inch).

The spring loaded jaws close around the conductor for measuring the current. A trigger switch controls the ammeter. The trigger switch can be locked into the ON position or into the OFF position.

After the trigger has been working and the trigger is turned to the OFF position, the reading appears in the digital display for five seconds. This accurately measures currents in areas with a limited access. For example, these areas include areas that are beyond the operator's sight. For DC operation, an ammeter contains a zero control, and batteries inside the handle supply the power.

## 237-5130 Digital Multimeter Gp or 146-4080 Digital Multimeter Gp

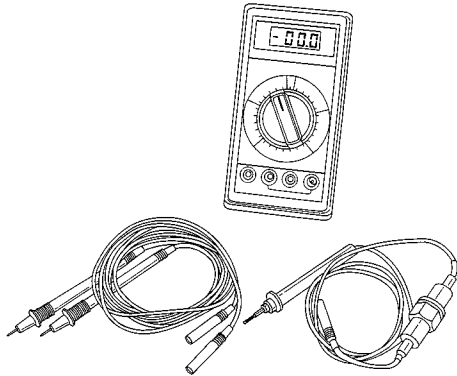

Illustration 95

g00283566

237-5130 Digital Multimeter Gp or 146-4080 Digital Multimeter Gp

The 237-5130 Digital Multimeter Gp and the 146-4080 Digital Multimeter Gp are portable hand-held service tools with a digital display. These multimeters are built with extra protection against damage in field applications. Both multimeters are equipped with 7 functions and 29 ranges. The 237-5130 Digital Multimeter Gp and the 146-4080 Digital Multimeter Gp have an instant ohms indicator. This indicator permits checking continuity for a fast inspection of the circuits. These multimeters can also be used for troubleshooting capacitors that have small values.

i02483828

## Electric Starting System - Test

**SMCS Code:** 1450-081

Most of the tests of the electrical system can be done on the engine. The wiring insulation must be in good condition. The wire and cable connections must be clean, and both components must be tight. The battery must be fully charged. If the on-engine test shows a defect in a component, remove the component for more testing.

The starting system consists of the following components:

- Keyswitch
- Starting motor solenoid
- Starting motor

Table 25

Tools Needed		
Part Number	Part Name	QTY
237-5130 or 146-4080	Digital Multimeter	1

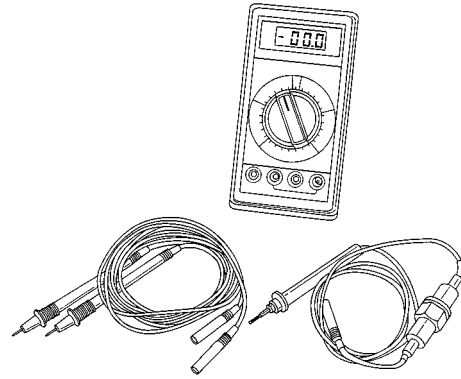

Illustration 96

g00283566

237-5130 Digital Multimeter or the 146-4080 Digital Multimeter

The 237-5130 Digital Multimeter Gp and the 146-4080 Digital Multimeter Gp are portable hand-held service tools with a digital display. These multimeters are built with extra protection against damage in field applications. Both multimeters are equipped with 7 functions and 29 ranges. The 237-5130 Digital Multimeter Gp and the 146-4080 Digital Multimeter Gp have an instant ohms indicator. This indicator permits checking continuity for a fast inspection of the circuits. These multimeters can also be used for troubleshooting capacitors that have small values.

**Note:** Refer to Special Instruction, SEHS7734 for complete information for the use of the 237-5130 Digital Multimeter. Refer to Operation Manual, NEHS0678 for complete information for the use of the 146-4080 Digital Multimeter.

Use the multimeter in the DCV range to find starting system components which do not function.

Move the start control switch in order to activate the starting solenoids. The starting solenoid's operation can be heard as the pinions of the starting motors are engaged with the ring gear on the engine flywheel.

If a solenoid for a starting motor will not operate, it is possible that the current from the battery did not reach the solenoid. Fasten one lead of the multimeter to the terminal connection for the battery cable on the solenoid. Touch the other lead to a good ground. A zero reading indicates that there is a broken circuit from the battery. More testing is necessary when there is a voltage reading on the multimeter.

The solenoid operation also closes the electric circuit to the motor. Connect one lead of the multimeter to the terminal connection of the solenoid that is fastened to the motor. Touch the other lead to a good ground. Activate the starting solenoid and look at the multimeter. A reading of the battery voltage shows that the problem is in the motor. The motor must be removed for further testing. A zero reading on the multimeter shows that the solenoid contacts do not close. This is an indication of the need for repair to the solenoid or an adjustment to be made to the pinion clearance for the starting motor.

Perform a test. Fasten one multimeter lead to the terminal connection for the small wire at the solenoid and fasten the other lead to the ground. Look at the multimeter and activate the starting solenoid. A voltage reading shows that the problem is in the solenoid. A zero reading indicates that the problem is in the start switch or the wires for the start switch.

Fasten one multimeter lead to the start switch at the terminal connection for the wire from the battery. Fasten the other lead to a good ground. A zero reading indicates a broken circuit from the battery. Make a check of the circuit breaker and wiring. If there is a voltage reading, the problem is in the start switch or in the wires for the start switch.

Starting motors that operate too slowly can have an overload because of too much friction in the engine that is being started. Slow operation of the starting motors can also be caused by a short circuit, loose connections and/or dirt in the motors.

i01335899

## Engine Oil Pressure Sensor - Test

**SMCS Code:** 1924-081

Refer to the Troubleshooting, RENR1367, "PC-42: Engine Oil Pressure Sensor Open Or Short Circuit Test" for information on checking the engine oil pressure sensor.

i01907823

## Exhaust Particulate Filter Diagnostic Module - Test

**SMCS Code:** 1091-081

**S/N:** G3E1-Up

**S/N:** DPF1-Up

The diagnostic module operates on 12 DCV to 24 DCV. While the vehicle is being operated the diagnostic module requires a constant current. The diagnostic module requires a current of 50 mA and a maximum of 150 mA. When the vehicle is not running the diagnostic module requires only a few mA. The small amount of current reduces the chance of battery drain. The diagnostic module has the ability to store 65,000 records internally. The diagnostic module is equipped with a lithium battery backup for unexpected power interruptions. The lithium battery has an expected life of ten years. The pressure transducer can not be replaced. The pressure transducer range is 0 to 20 in Hg. The thermocouple has an operating temperature range of 0 to 1000°C (32° to 1832°F).

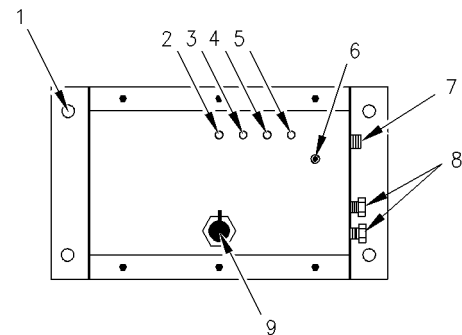

Illustration 97

g00885031

Diagnostic module

- (1) 4 Mounting holes
- (2) "System status" light
- (3) "Over-pressure alarm" light
- (4) "Over-temp alarm" light
- (5) "System problem" light
- (6) "Alarm reset button"
- (7) "Pressure transducer port"
- (8) "Wire passage"
- (9) "Serial data comm port"

The diagnostic module is equipped with alarms to warn you about the operation of the exhaust. The diagnostic module has the following features:

- Mounting holes are used to secure the diagnostic module to the vehicle.

- “System status” light is green. The light will blink in two second intervals. This indicates that the system is working properly.
- “Over-pressure alarm” is activated when the exhaust back pressure has exceeded the programmed value. “Over-pressure alarm” activates the engine derate.
- “Over-temp alarm” is activated when the exhaust temperature exceeds the programmed value.
- System problems will activate the warning light when there is a problem with the diagnostic module.
- “Alarm reset button” will clear active alarms. Clearing the alarms will deactivate the derate.
- “Pressure transducer port” is the location for the copper tubing which measures the exhaust back pressure.
- The wires enter the diagnostic module through the wire passage.
- “Serial data comm port” will allow the technician to view the logged data. The logged data will show the changes of the pressure and the temperature of the exhaust system. The technician can also view the temperature and pressure of the exhaust system when the engine is running.

The alarms are displayed to the driver in the form of an amber light and red light. The lights get the signal from the diagnostic module. Refer to Operation and Maintenance Manual, SEBU7011 for additional information.

The parameters of the diagnostic module are listed in Table 26.

Table 26

<b>System over temperature</b>	
	Active alarm
	Log the events that caused the alarm.
	Output 1
	Output signal is activated during the alarm.
	Activate the alarm above 650° ± 20°C (1202° ± 36°F) .
	Activate the alarm for 60 seconds.
<b>System over pressure</b>	

(continued)

(Table 26, contd)

<b>Warning</b>	Active alarm
	Log the events that caused the alarm.
	Output 1
	Output signal is activated during the alarm.
<b>Alarm</b>	Activate the alarm when the pressure is above 7 in Hg for more than 5% of the time in a 60 minute interval.
	Active alarm
	Log the events that caused the alarm.
	Output 2
<b>Strategy for data logging</b>	Output turned on.
	Activate the alarm above 8 in Hg when the value is exceeded for more than 5% of the time during a 60 minute interval.
	Rotation of memory
	Logging enabled above 100 °C (212 °F)
<b>Failure of thermocouple</b>	10 minute interval of records
	Active alarm
	Log the events that caused the alarm.
<b>Open thermocouple</b>	Output 1
	Output turned on.
	Activate the alarm above 1000 °C (1832 °F).
	Active alarm
<b>Shorted thermocouple</b>	Log the events that caused the alarm.
	Output 1
	Output turned on.
	Activate the alarm when the pressure is above 1 in Hg for 10 minutes and temperature does not exceed 120 °C (248 °F).
<b>Failure of pressure sensor</b>	
<b>Alarm for constant pressure</b>	Active alarm
	Log the events that caused the alarm.
	Output 1
	Output turned on.
	Activate the alarm when the temperature is above 250 °C (482 °F) for 10 minutes and the pressure does not change by at least 1 in Hg.

(continued)

(Table 26, contd)

<b>Alarm for negative pressure</b>	Active alarm
	Log the events that caused the alarm.
	Output 1
	Output turned on.
	Activate the alarm when the temperature is above 200 °C (392 °F) for 1 minute and the pressure is less than -1 in Hg.

i02237991

## Pinion Clearance - Adjust

**SMCS Code:** 1454-025

### Electric Starting Motor

When the solenoid is installed, make an adjustment of the pinion clearance. The adjustment can be made with the starting motor removed.

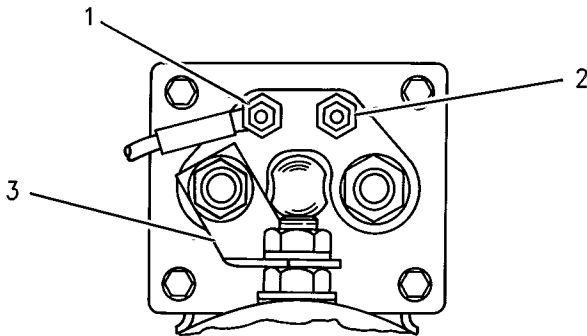

Illustration 98

g01134792

Connection for checking pinion clearance

- (1) Ground terminal
- (2) Switch terminal
- (3) Connector to the motor

1. Install the solenoid without connector (3) from the MOTOR connections (terminal) on the solenoid to the motor.
2. Connect a battery, that has the same voltage as the solenoid, to the "SW" terminal (2).
3. Connect the other side of the battery to connector (3).
4. For a moment, connect a wire from the solenoid connection (terminal), which is marked "MOTOR", to the ground connection (terminal). The pinion will shift to the crank position and the pinion will stay there until the battery is disconnected.

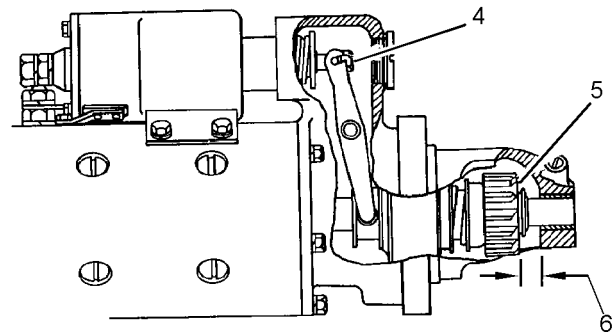

Illustration 99

g01097827

- (4) Shaft nut
- (5) Pinion
- (6) Pinion clearance

5. Push the pinion toward the end with the commutator in order to remove free movement.
6. Pinion clearance (6) must be 9.1 mm (0.36 inch).
7. In order to adjust the pinion clearance, remove the plug and turn the shaft nut (4).
8. After the adjustment is completed, install the plug over the nut (4) and install the connector (3) between the MOTOR terminal on the solenoid and the starter motor.

i01357620

## Pinion Clearance - Adjust

**SMCS Code:** 1454-025

When the solenoid is installed, make an adjustment of the pinion clearance. The adjustment should be made with the starting motor removed.

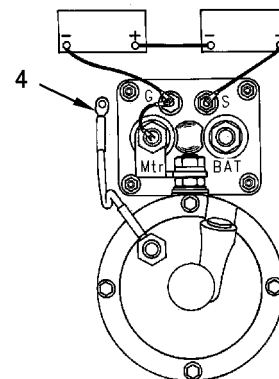

Illustration 100

g00716453

Connections for pinion clearance check

- (4) Starting motor negative wire

1. Disconnect the starting motor negative wire (4) from the "G" ground terminal of the solenoid.
2. Connect the batteries to the solenoid per Illustration 100. The Illustration shows a 24 volt system with two 12 volt batteries that are connected in series to a starting motor. Connect four 8 volt batteries in series for a 32 volt system. Connect eight 8 volt batteries in series for a 64 volt system. Connect the positive side of the battery cable to the "S" terminal of the starting motor solenoid. Connect the negative side of the battery cable to the "G" terminal of the starting motor .
3. Temporarily, touch a wire from the "G" terminal to the "Mtr" terminal. The pinion will shift to the crank position and the pinion will stay there until the battery is disconnected.

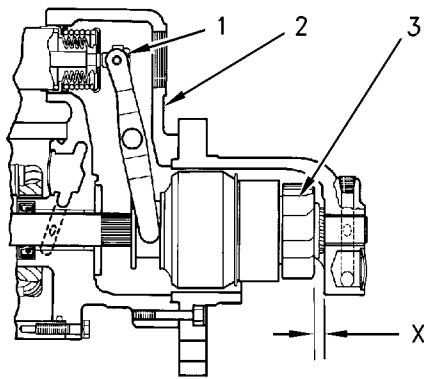

Illustration 101

g00716455

## Pinion clearance check

- (1) Adjustment nut
- (2) Pinion drive housing
- (3) Pinion
- (X) pinion clearance

4. Push the pinion toward the commutator in order to remove free movement.
5. Measure the clearance (X) from the pinion to the pinion drive housing. Pinion clearance (X) must be  $9.10 \pm 0.8$  mm ( $0.36 \pm 0.03$  inch).
6. If the clearance is not correct, remove the plug on the shift lever housing (2). Turn the adjustment nut (1) until the clearance is correct. Turning the nut clockwise will decrease the clearance (X).

**Note:** The plunger may turn when the adjustment nut (1) is being turned. If the plunger turns, disconnect the battery from the solenoid. Remove the solenoid from the starting motor. Hold the plunger from turning and adjust the nut (1). This procedure may need to be performed several times until the correct clearance is obtained.

7. Disconnect the batteries and install the plug into the shift lever housing.

# Index

## A

Aftercooler - Test .....	69
Aftercooler Core Leakage .....	70
Air System Restriction.....	71
Dynamometer Test.....	72
Turbocharger Failure .....	72
Visual Inspection.....	69
Air in Fuel - Test.....	53
Air Inlet and Exhaust System .....	36, 62
Air Inlet Heater .....	38
Turbocharger .....	37
Valve System Components.....	38
Air Inlet and Exhaust System - Inspect.....	62
Air Inlet Restriction.....	62
Exhaust Back Pressure.....	63
Exhaust Restriction.....	63

## B

Basic Engine.....	45, 90
Camshaft.....	47
Crankshaft.....	46
Cylinder Block And Head .....	45
Piston, Rings And Connecting Rods.....	45
Vibration Damper .....	47
Battery - Test .....	97

## C

Charging System - Test .....	98
Test Tools For The Charging System.....	98
Compression - Test.....	73
Connecting Rod Bearings - Inspect.....	90
Cooling System .....	42, 81
Coolant Conditioner (If Equipped).....	44
Coolant For Air Compressor (If Equipped).....	44
Cooling System - Check (Overheating).....	81
Cooling System - Inspect.....	83
Cooling System - Test.....	84
Checking the Filler Cap.....	86
Making the Correct Antifreeze Mixtures.....	86
Test For The Water Temperature Gauge .....	87
Test Tools For Cooling System .....	84
Testing The Radiator And Cooling System For Leaks.....	87
Cylinder Block - Inspect.....	90

## E

Electric Starting System - Test.....	99
--------------------------------------	----

Electrical System .....	48, 97
Charging System Components.....	49
Engine Electrical System .....	48
Grounding Practices .....	48
Starting System Components .....	50
Engine Crankcase Pressure (Blowby) - Test.....	72
Engine Oil Pressure - Test.....	76
Measuring Engine Oil Pressure .....	76
Reason for High Engine Oil Pressure .....	78
Reasons for Low Engine Oil Pressure .....	77
Engine Oil Pressure Sensor - Test .....	100
Engine Oil Pump - Inspect.....	79
Engine Speed - Check.....	54
Engine Valve Lash - Inspect/Adjust.....	73
Valve Lash and Valve Bridge Adjustment .....	74
Valve Lash Check .....	73
Excessive Bearing Wear - Inspect.....	79
Excessive Engine Oil Consumption - Inspect.....	79
Oil Leakage Into Combustion Area Of Cylinders .....	79
Oil Leakage On Outside Of Engine.....	79
Exhaust Particulate Filter Diagnostic Module - Test .....	100
Exhaust Temperature - Test.....	69

## F

Finding Top Center Position for No. 1 Piston.....	55
Flywheel - Inspect.....	91
Bore Runout (radial eccentricity) of the Flywheel.....	91
Face Runout (axial eccentricity) of the Flywheel.....	91
Flywheel Housing - Inspect .....	92
Bore Runout (Radial Eccentricity) of the Flywheel Housing.....	92
Face Runout (Axial Eccentricity) of the Flywheel Housing.....	92
Fuel Quality - Test.....	56
Fuel System.....	7, 52
Component Description .....	8
Components of the HEUI Injector .....	21
Fuel Heater And Water Separator (If Equipped)..	35
HEUI Fuel System Operation.....	10
Introduction .....	7
Operation of the HEUI Fuel Injector.....	25
Fuel System - Inspect.....	52
Checking The Operation Of Individual Cylinders .....	53
Initial Inspection Of The Fuel System .....	52
Inspection With The Engine Running.....	53
Start Up Procedure .....	52
Fuel System - Prime .....	57
Fuel System Pressure - Test .....	58



**G**

Gear Group (Front) - Time.....	60
General Information.....	4
Cold Mode Operation.....	6
Starting The Engine .....	5

**I**

Important Safety Information .....	2
Increased Engine Oil Temperature - Inspect .....	80
Inlet Manifold Pressure - Test.....	68

**L**

Lubrication System .....	40, 76
--------------------------	--------

**M**

Main Bearings - Inspect.....	90
------------------------------	----

**P**

Pinion Clearance - Adjust.....	102
Electric Starting Motor.....	102
Piston Ring Groove - Inspect.....	90

**S**

Systems Operation Section .....	4
---------------------------------	---

**T**

Table of Contents.....	3
Testing and Adjusting Section .....	52
Turbocharger - Inspect .....	65
Inspection of the Compressor and the Compressor Housing .....	66
Inspection of the Turbine Wheel and the Turbine Housing .....	66
Inspection of the Wastegate .....	67

**U**

Unit Injector - Test.....	60
---------------------------	----

**V**

Vibration Damper - Check .....	94–95
Rubber Vibration Damper (If Equipped).....	94–95
Viscous Vibration Damper .....	96
Viscous Vibration Damper (If Equipped).....	94

**W**

Water Pump - Test.....	89
Water Temperature Regulator - Test .....	88





