



LTB01254NAS1

TECHNICAL BULLETIN

24 OCT 2018

© Jaguar Land Rover North America, LLC

NOTE: The information in Technical Bulletins is intended for use by trained, professional Technicians with the knowledge, tools, and equipment required to do the job properly and safely. It informs these Technicians of conditions that may occur on some vehicles, or provides information that could assist in proper vehicle service. The procedures should not be performed by 'do-it-yourselfers'. If you are not a Retailer, do not assume that a condition described affects your vehicle. Contact an authorized Land Rover service facility to determine whether this bulletin applies to a specific vehicle.

INFORMATION

SECTION:

303-12

SUBJECT/CONCERN:

Engine MIL Illuminated With DTC P0299-77 Stored

AFFECTED VEHICLE RANGE:

MODEL:	MODEL YEAR:	VIN:	APPLICABILITY:
Discovery (LR)	2017-2018	000001-075312	TDV6 3.0L Diesel
Range Rover Sport (LW)	2016-2018	100003-808712	TDV6 3.0L Diesel
Range Rover (LG)	2016-2018	212697-510666	TDV6 3.0L Diesel

MARKETS:

NORTH AMERICA

CONDITION SUMMARY:

SITUATION:

The engine MIL (Malfunction Indicator Lamp) may be illuminated and a restricted performance message may be displayed. Upon further investigation, DTC (Diagnostic Trouble Code) P0299-77 is stored in the Powertrain Control Module (PCM).

CAUSE:

This may be caused by the charge air cooler hose collapsing internally.

NOTE:

DTC P0299-77 can be set for multiple reasons. Perform all required checks for this DTC before renewing the charge air cooler hose.



ACTION:

Should a customer express this concern, follow the appropriate Diagnostic Procedure, Inspection Procedure, and Workshop Procedure (if necessary) below.

PARTS:

PART NUMBER	DESCRIPTION	QUANTITY
LR117083	Charge air cooler hose	1

TOOLS:

 <p>E20406</p>	<p>Jaguar Land Rover-approved Midtronics battery power supply</p>	 <p>E208514</p>	<p>Jaguar Land Rover-approved diagnostic equipment with latest PATHFINDER software</p>
 <p>E179225</p>	<p>Jaguar Land Rover-approved diagnostic equipment with latest SDD Software Management Pack</p>		

WARRANTY:

NOTES:

- Repair procedures are under constant review, and therefore times are subject to change; those quoted here must be taken as guidance only. Always refer to JLR claims submission system to obtain the latest repair time.
- The JLR Claims Submission System requires the use of causal part numbers. Labor only claims must show the causal part number with a quantity of zero.

DESCRIPTION	SRO	TIME (HOURS)	CONDITION CODE	CAUSAL PART
Read / clear fault codes	12.90.16	0.2	42	LR116344
Leakage test using smoke test equipment	01.01.28	0.4	42	LR116344
Hose - Intercooler to induction manifold - Renew	19.42.26	0.1	42	LR116344

NOTE:

Normal Warranty procedures apply.

DIAGNOSTIC PROCEDURE:

This Diagnostic Procedure is for the following vehicles: 2016MY Range Rover Sport; 2016MY Range Rover.

ⓘ CAUTIONS:

- A Jaguar Land Rover-approved Midtronics battery power supply must be connected to the vehicle startup battery.
- All ignition ON/OFF requests MUST be performed; failure to do so may cause damage to vehicle control modules.

1 Connect the Jaguar Land Rover-approved Midtronics battery power supply to the vehicle startup battery.

⚠ NOTE:

The Jaguar Land Rover-approved diagnostic equipment must be loaded with SDD154.05 Software Management Pack v303 (or later).

Connect the Jaguar Land Rover-approved diagnostic equipment to the vehicle and begin a new session.

3 Follow all on-screen instructions.

⚠ NOTE:

DTC P0299-77 can be set for multiple reasons. Perform all required checks for this DTC, before renewing the charge air cooler hose.

Read all DTCs.

- If DTC P0299-77 is stored, go to the Inspection Procedure below.
- If DTC P0299-77 is not stored, do not continue with this Technical Bulletin.
 - Diagnose using TOPIx Workshop Manual section 100-00: General Information - Diagnostic Trouble Code Index.

5 Select the **Clear DTCs** option.

1 Follow the on-screen instructions until the application finishes successfully.

6 Exit the current session.

- 1 Select the **Session** tab.
- 2 Select the **Close Session** option.

7 Disconnect the diagnostic equipment and battery power supply from the vehicle.

DIAGNOSTIC PROCEDURE:

This Diagnostic Procedure is for the following vehicles: 2017-18MY Discovery; 2017-18MY Range Rover Sport; 2017-18MY Range Rover.

ⓘ CAUTIONS:

- A Jaguar Land Rover-approved Midtronics battery power supply must be connected to the vehicle startup battery.
- All ignition ON/OFF requests MUST be performed; failure to do these steps may cause damage to vehicle control modules.

1 Connect the Jaguar Land Rover-approved Midtronics battery power supply to the vehicle startup battery.

⚠ NOTE:

The Jaguar Land Rover-approved diagnostic equipment must be loaded with PATHFINDER version 193 (or later).

Connect the Jaguar Land Rover-approved diagnostic equipment to the vehicle and begin a new session.

3

NOTE:

The Jaguar Land Rover-approved diagnostic equipment will read the correct Vehicle Identification Number (VIN) for the current vehicle and automatically take the vehicle out of Transit mode (if required).

Follow all on-screen instructions.

4

Select **ECU Diagnostics**.

5

NOTE:

DTC P0299-77 can be set for multiple reasons. Perform all required checks for this DTC before renewing the charge air cooler hose.

Select **All DTCs**.

- If DTC P0299-77 is stored, go to the Inspection Procedure below.
- If DTC P0299-77 is not stored, do not continue with this Technical Bulletin.
 - Diagnose using TOPIx Workshop Manual section 100-00: General Information - Diagnostic Trouble Code Index.

6

Select **Clear all DTCs**.

- 1 Follow the on-screen instructions until the application finishes successfully.

7

Exit the current session.

- 1 If required, reset the vehicle to **Transit mode**.
- 2 Select the **Exit** icon.

8

Disconnect the diagnostic equipment and battery power supply from the vehicle.

INSPECTION PROCEDURE:**NOTES:**

- This procedure contains some variation in the illustrations depending on the vehicle specification, but the essential information is always correct.
- This procedure contains illustrations showing certain components removed to provide extra clarity.
- DTC P0299-77 can be set for multiple reasons. Perform all required checks for this DTC before renewing the charge air cooler hose.

1

Check the engine oil level.

- If excessive engine oil level is not found, go to Step 2.
- If excessive engine oil level is found:
 - Investigate and rectify using TOPIx repair procedures.
 - Recheck the vehicle.
 - To be performed as a separate claim.

2

Check for excessive oil within the air induction system.

- If excessive engine oil within the induction system is not found, go to Step 3.
 - If excessive engine oil within the induction system is found:
 - Investigate and rectify using TOPIx repair procedures.
 - Recheck the vehicle.
 - To be performed as a separate claim.
-

3 Check for an exhaust system leak.

- If an exhaust system leak is not found, go to Step 4.
 - If an exhaust system leak is found:
 - Investigate and rectify using TOPIx repair procedures.
 - Recheck the vehicle.
 - To be performed as a separate claim.
-

4 Check the charge air pressure sensor for blockage.

- If the charge air pressure sensor is not blocked, go to Step 5.
 - If the charge air pressure sensor is blocked:
 - Investigate and rectify using TOPIx repair procedures.
 - Recheck the vehicle.
 - To be performed as a separate claim.
-

5 Check the turbocharger system/vanes mechanical integrity.

- If the turbocharger is not faulty, go to Step 6.
 - If the turbocharger is faulty:
 - Investigate and rectify using TOPIx repair procedures.
 - Recheck the vehicle.
 - To be performed as a separate claim.
-

6 Complete a leakage test on the vehicles induction system (see TOPIx Workshop Manual 303-00: Engine System - General Information - General Procedures - Leakage Test Using Smoke Test Equipment).

- If a leak is not found, go to the Workshop Procedure below.
 - If a leak is found, do not continue with this Technical Bulletin:
 - Investigate and rectify using TOPIx repair procedures.
 - Recheck the vehicle.
 - To be performed as a separate claim.
-

WORKSHOP PROCEDURE:

1 Remove the engine cover (see TOPIx Workshop Manual section 501-05: Interior Trim and Ornamentation - Removal and Installation - Engine Cover).

- **Discovery:** go to Step 3.
- **Range Rover Sport, Range Rover:** go to Step 2

2

NOTES:

- Some components are removed for clarity.
- Range Rover Sport, Range Rover only.

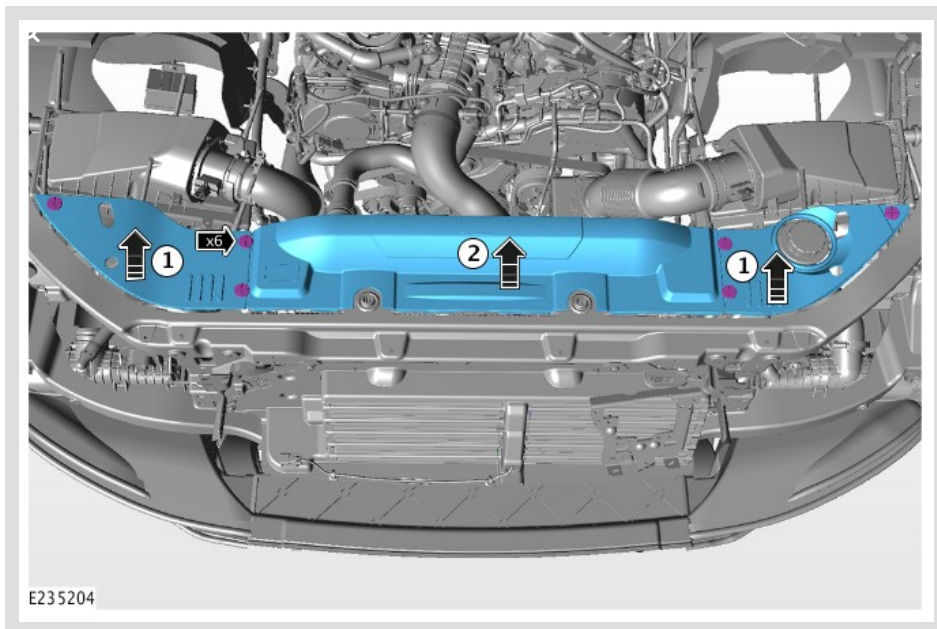

Remove the engine compartment front trim covers.

- Remove the 6 fasteners.
- Lift the left and right outer covers upwards.
- Pull the center trim upwards.

3

NOTES:

- Some components are removed for clarity.
- Discovery only.

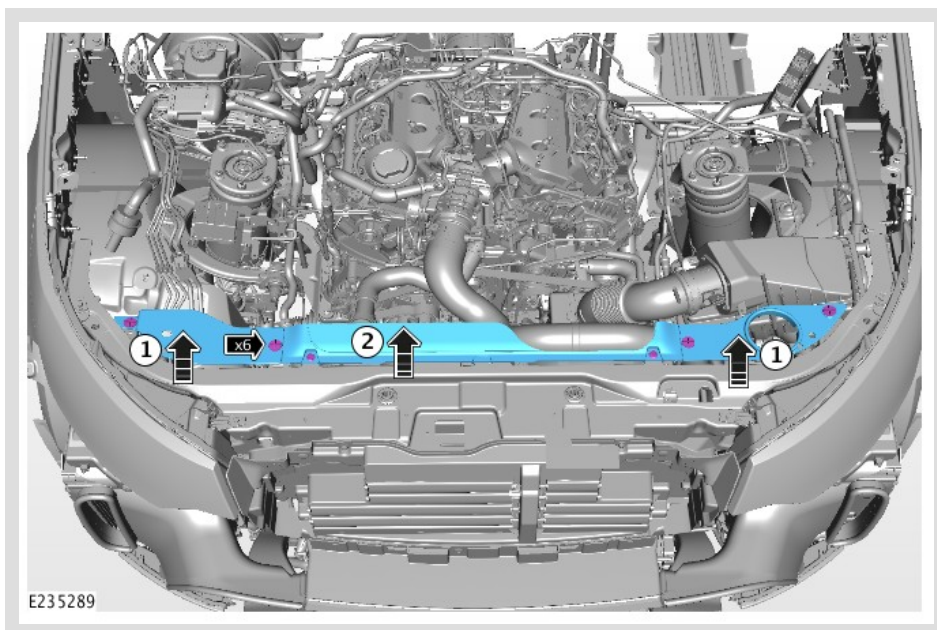

Remove the engine compartment front trim covers.

- 1 Remove the 5 fasteners.
- 2 Lift the left and right outer covers upwards.
- 3 Pull the center trim upwards.

4

NOTE:

Some components are removed for clarity.

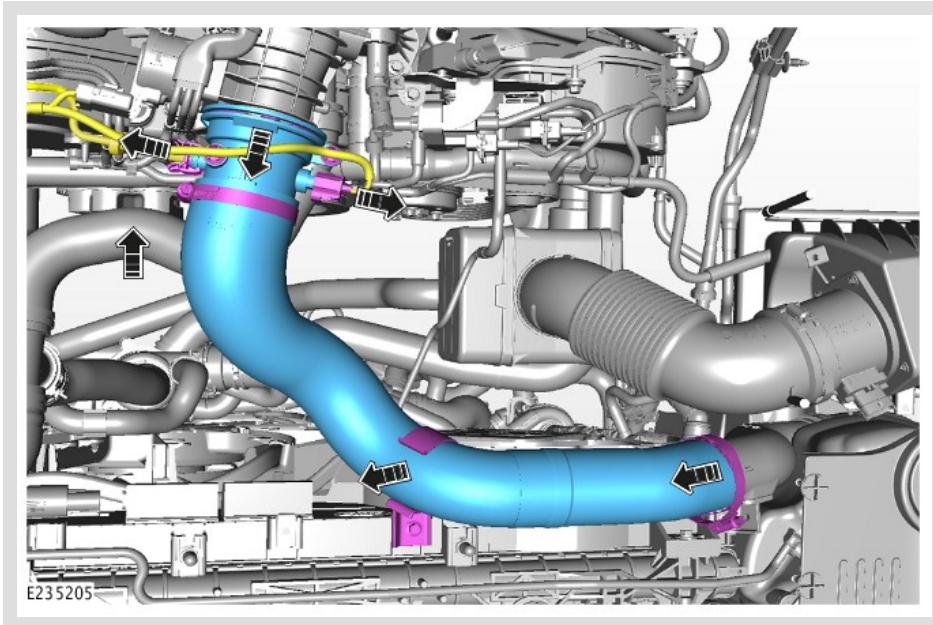

Remove and discard the charge air cooler hose.

- 1 Disconnect the vacuum pipe from the charge air cooler hose.
- 2 Disconnect the electrical connector from the charge air cooler hose.
- 3 Release the securing clip.
- 4 Disconnect the charge air cooler hose from the electronic throttle body.
- 5 Disconnect the charge air cooler hose from the top of the charge air cooler.

5

Renew the charge air cooler hose.

- 1 Connect the charge air cooler hose to the top of the charge air cooler.
- 2 Connect the charge air cooler hose to the electronic throttle body.
- 3 Attach the securing clip.
- 4 Connect the electrical connector to the charge air cooler hose.
- 5 Connect the vacuum pipe to the charge air cooler hose.

6

Install the engine compartment front trim cover.

- **Discovery:** reverse Step 3 sub-steps.
- **Range Rover Sport, Range Rover:** reverse Step 2 sub-steps.

7

Install the engine cover (see TOPIx Workshop Manual section 501-05: Interior Trim and Ornamentation - Removal and Installation - Engine Cover).