

DEPARTMENT OF THE ARMY TECHNICAL MANUAL

OPERATOR'S MANUAL

LATHE, BRAKE DRUM, FLOOR

MOUNTED, 60-INCH RATED SWING,

9-TO 25-INCH DRUM DIAMETER,

10-INCH MAXIMUM CUTTING DEPTH,

STATIONARY CUTTING TOOL TYPE,

1/2-HP, AC, 10/220-VOLT, 60-CYCLE,

SINGLE PHASE

(LEMPCO PRODUCTS, INC. MODEL 802)

(4910-516-6192)

HEADQUARTERS, DEPARTMENT OF THE ARMY
SEPTEMBER 1965

HEADQUARTERS
DEPARTMENT OF THE ARMY
WASHINGTON, D. C., 31 September 1965

TM 9-4910-452-10 is published for the information and use of all concerned.

By Order of the Secretary of the Army:

HAROLD K. JOHNSON,
General, United States Army,
Chief of Staff.

Official:

J. C. LAMBERT,
Major General, United States Army,
The Adjutant General.

Distribution:

Active Army:

DCSLOG (1)	EUSA (5)	9-25	29-21
CNGB (1)	Corps (2)	9-26	29-25
TSG (1)	USAC (2)	9-45	29-26
CofEngrs (6)	Ft Belvoir (2)	9-66	29-45
CofSptsS (2)	USAAVCOM (10)	9-127	29-36
Dir of Trans (1)	Redstone Arsenal (1)	9-197	29-41
CC-E (1)	UMAD (1)	9-217	29-51
USCONARC (3)	LEAD (2)	9-227	29-45
USAMC (12)	TEAD (16)	9-357	2946
ARADCOM (2)	LBAD (1)	9-500 (CA,CC,DA)	2965
ARADCOM Rgn (2)	4th USASA Fid Sta (1)	10-445	29-75
OS Maj Comd (1)	Units org under fol TOE:	10-448	29-79
LOGCOMD (3)	(2 copies each)	17	29-105
USASMC (6)	6-35	17-100	29-109
USAWECOM (75)	7	29-1	37
Armies (3) except	7-100	29-11	37-100
Second USA (2)	9-7	29-16	57
Seventh USA (5)	9-9	2916	67-100

NG: None.

USAR: None.

For explanation of abbreviations used, see AR 320-50.

Changes in force: C1

Change }
 No. 1 }

HEADQUARTERS
 DEPARTMENT OF THE ARMY
 Washington, DC, 29 June 1973

**Operator's Manual
 LATHE, BRAKE DRUM, FLOOR MOUNTED,
 60-INCH RATED SWING, 9- TO 25-INCH DRUM DIAMETER,
 10-INCH MAXIMUM CUTTING DEPTH, STATIONARY CUTTING
 TOOL TYPE, 1/2-HP, AC, 110/220-VOLT, 60-CYCLE,
 SINGLE PHASE
 (BEAR MFG CO, MODEL 1410)
 (4910-516-6192)**

TM 9-4910-452-10, 30 September 1965, is changed as follows:

Change title to read as above.

After Page 15. Add the following paragraphs:

Recommendations for Maintenance Publications Improvements.

You can improve this manual by calling attention to errors and by recommending improvements using DA

Form 2028 (Recommended Changes to Publications) or by a letter and mailing directly to Commander, US Army Weapons Command, ATTN: AMSWE-MAS-SP, Rock Island IL 61201. A reply will be furnished directly to you.

Components of the End Item.

Parts included with the end item and considered as components of the end item configuration are listed in the following table:

Table 1. Component of the End Item

Components	Part No.	(FSCM)	Qty
ADAPTER, CONNECTOR:	5273L	(74545)	1
ADAPTER, RADII:	802-2458-30G	(06365)	1
ADAPTER, RADII:	802-2458-31G	(06365)	2
ADAPTER, RADII:	802-2458-32G	(06365)	2
ADAPTER, RADII:	802-2458-34G	(06365)	1
ADAPTER, RADII:	802-2458-33G	(06365)	1
ARBOR ASSY: 1 in.	802-2455-1	(06365)	1
ARBOR ASSY: 2 in.	802-1500GQS	(06365)	1
ARBOR ASSY: shoulder	505-1500QS	(06365)	1
BAR, BORING:	802-2106	(06365)	1
BAR, TOOL:	802-2455-8	(06365)	1
BIT, TOOL:	Y-211	(06365)	2
BIT, TOOL:	Y-283A	(06365)	2
CABINET ASSEMBLY:	802-501QS	(06365)	1
CHATTER ELIMINATOR, DRUM:	E-1	(06365)	1
CONE, CENTERING:	802-2450-20	(06365)	1
CONE, CENTERING:	802-2450-21	(06365)	1
CONE, CENTERING:	802-2450-22	(06365)	1
CONE, RADII:	802-2450-16	(06365)	1
CONE, RADII:	802-2450-8	(06365)	1
CONE, RADII:	802-2450-14	(06365)	1
CONE, RADII:	802-2450-9	(06365)	1
CONE, RADII:	802-2450-15	(06365)	1
CONE, RADII:	802-2450-10	(06365)	1
CONE, RADII:	802-2450-12	(06365)	1
CONE, RADII:	802-2450-11	(06365)	1
CONE, RADII:	802-2450-13	(06365)	1
CONE, STEP:	505-2078-1	(06365)	1
CONE, STEP:	505-2079-A1	(06365)	1
CONE, STEP:	802-2457-2	(06365)	1
CONE, STEP:	802-2458-3	(06365)	1
CONE, TAPER:	Y-131-4A	(06365)	1
CONE, TAPER:	Y-132-4B	(06365)	1
CONE, TAPER:	802-2450-6	(06365)	1
CONE, TAPER:	802-2450-7	(06365)	1
CONE, TAPER:	505-2142	(06365)	1
CONE, TAPER:	505-2143	(06365)	1
CONE, TAPER:	Y-225A	(06365)	1
CONE, TAPER:	Y-226	(06365)	2
CONE, TAPER:	802-2455-4	(06365)	1
CONE, TAPER:	802-2455-5	(06365)	1
PLATE, FACE:	802-2457-1	(06365)	2
REDUCER, ARBOR:	802-2450-5	(06365)	1
SPACER, ARBOR:	DH-1030	(06365)	1
SPACER, ARBOR:	DH-1031	(06365)	1
SPACER, ARBOR:	X-24-4G	(06365)	1
SPACER, ARBOR:	X-24-4H	(06365)	1
SPACER, ARBOR:	X-24-4J	(06365)	1
SPACER, ARBOR:	802-2450-4	(06365)	2
SPACER, ARBOR:	802-2450-3	(06365)	4
SPACER, ARBOR:	Y-135-5D	(00365)	1
SPRING, FACE PLATE:	802-2450-26	(06365)	1
SUPPORT, OUTBOARD:	503-3012GQS	(06365)	1
WRENCH, ARBOR:	DH-2048WR	(06365)	1
WRENCH, SPANNER:	464	(03914)	1
WRENCH, SPANNER:	802-2450-17	(06365)	1

**APPENDIX
BASIC ISSUE ITEMS LIST
AND
ITEMS TROOP INSTALLED OR AUTHORIZED LIST**

Section I. INTRODUCTION

1. Scope.

This appendix lists basic issue items and items troop installed or authorized required by the crew/operator for operation of the Brake Drum Lathe.

2. General.

This Basic Issue Items List and Items Troop Installed or Authorized List is divided into the following sections:

- a. *Basic Issue Items List.* Not applicable.
- b. *Items Troop Installed or Authorized List.* Not applicable.

By Order of the Secretary of the Army:

Official:

VERNE L. BOWERS
*Major General, United States Army
The Adjutant General*

CREIGHTON W. ABRAMS
*General, United States Army
Chief of Staff*

Distribution:

Active Army: To be distributed in accordance with DA Form 12-38 (qty rqr block No. 250) organizational maintenance requirements for Truck, Utility, 1/4 Ton, M151 and DA Form 12-40 (qty rqr block No. 136) organizational maintenance requirements for Rifle, 5.56MM, M16, M16A1.

NG: State AG (3)

USAR: None

☆US. GOVERNMENT PRINTING OFFICE: 1973-769752/5214

CONTENTS

OPERATING INSTRUCTIONS

	Page
Introduction	3
Unpacking	3
Setting Up Lathe	3
Motor Connections	3
General Care of Machine and Attachments	3
Care of Arbor and Attachments	4
Lubrication	4
Adjustment of Carriage and Cross Slide Gibs	5
Carriage Feeding System	5
Installing and Removing Arbor	5
Mounting Work	5
Mounting Instructions for Outboard Support	7
How to Set Position Indicator	7
Truing Operation	8

PARTS LIST

Main Assembly	9
Carriage Assembly	9
Motor Drive	9
Electrical Equipment	9-10
Standard Equipment	10

DRAWINGS

Main Assembly	11-12-13
Main Assembly Tail Stock Stand	14

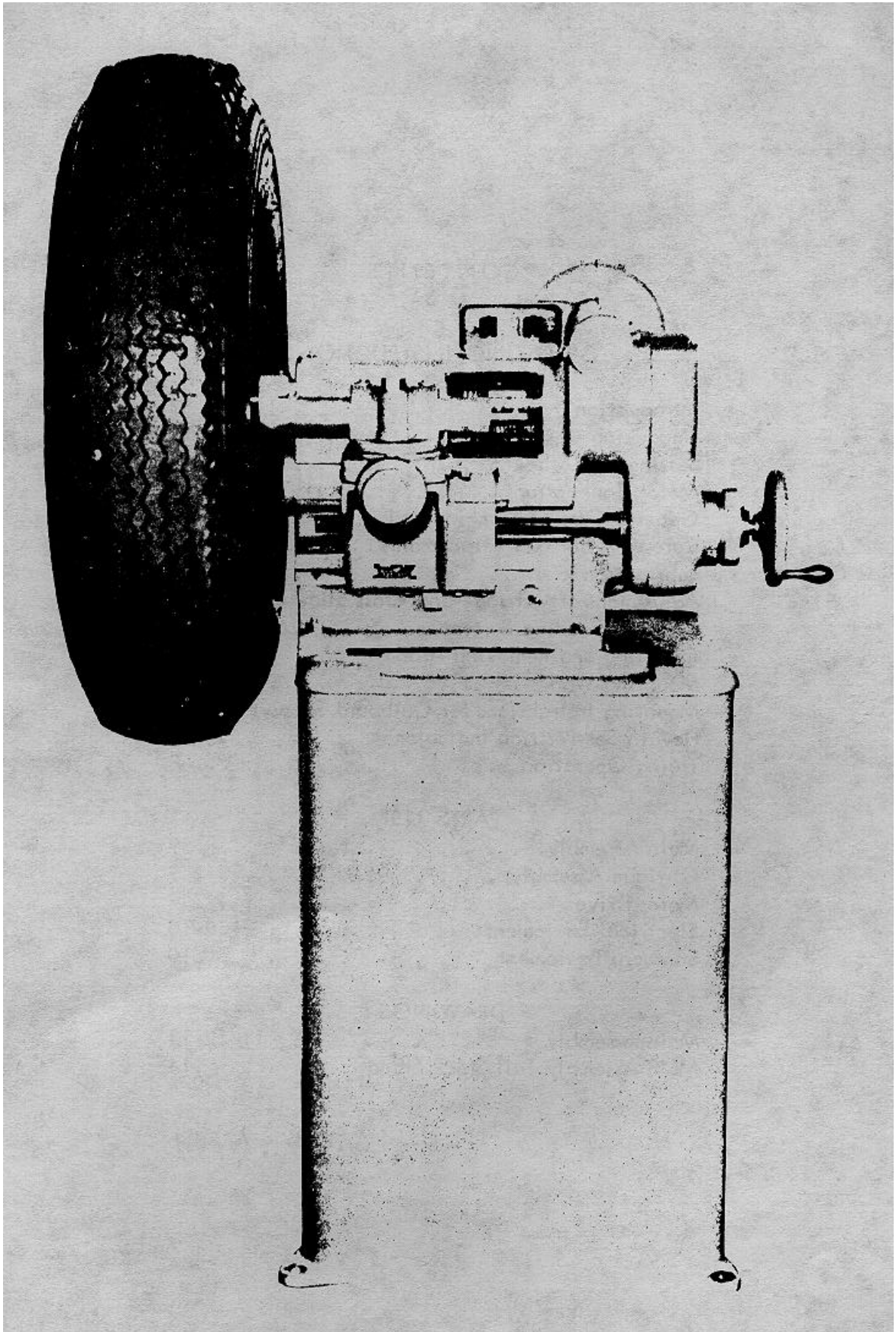

OPERATING INSTRUCTIONS - BRAKE DRUM LATHE

Introduction

This instruction manual covers recommendations relative to the care and operation of the Brake Drum Lathe.

"Care of the Lathe" includes proper installation, close adherence to lubrication specifications with particular emphasis on oiling, and last, but not least, general rules governing cleanliness which must be followed at all times to retain the features of accuracy which have been built into the machine at the factory.

"Operation of the Lathe" includes various methods of mounting the drum on spindle, selection of correct spindle speeds and feeds, and a thorough knowledge of the function and use of all controls.

The importance of thorough reading and study of this entire manual cannot be emphasized too strongly and strict adherence to recommendations will result in faster setups, higher quality work, and longer tool and machine life.

UNPACKING

If preliminary inspection indicates the machine has arrived in good condition, the crate may be removed, **BUT DO NOT REMOVE THE SKIDS AT THIS TIME.** Be particularly careful not to pry against any part of the machine with a bar. Also be careful if using a heavy hammer or sledge, not to miss the crate and hit some vital part of the machine. Remove all packing paper.

After unpacking, take time to check to see if there is any damage which may not have shown up during the initial inspection.

SETTING UP LATHE

Remove lathe from skids and place on floor. Lag lathe to floor with lag bolts through the four corner holes.

MOTOR CONNECTIONS

Before connecting motor to line, be sure line voltage is the same as voltage stamped on tag attached to lead cable from motor. All lathes are wired for 115 volt AC at the factory. Any other voltage is by special order. A polarized plug with adapter is standard equipment on each lathe.

When electrical connections are made and lathe is operating, check rotation of work spindle. When standing on operator's side of lathe looking at top of spindle, top of spindle should turn towards you, or when looking at arbor end of spindle, spindle should rotate clockwise.

GENERAL CARE OF MACHINE AND ATTACHMENTS

Cleanliness is more than a virtue when it relates to machine tools. It is an absolute necessity to insure long life and correct functioning of the machine.

KEEP ALL MACHINED SURFACES CLEAN

The carriage and cross slide ways, likewise the top cross slides and bottom of the tool compound have perfect bearing between reciprocating parts. Borings, particularly those of cast iron, and even dust in the machine shop, are highly abrasive and if not wiped off the ways, will soon wear them out.

Do not assume that if ways wear, it can be taken up by adjusting the gibs. The gibs are useful for adjustment only as long as ways are straight. Worn ways, however, are never straight because they wear only at points in contact with chips or abrasives and only at points where carriage and cross slides are used the most. The balance of the ways remain much the same as when new. Then if gibs are adjusted to cause slides to work correctly at these worn points, slides will work too tightly, or it may be impossible to pass them over the unworn portions. Worn ways can only be corrected by scraping.

Keep work end of spindle wiped clean; it is a good policy to wipe it off every job. To insure correct fit of adapter, spindle end must be immaculately clean. Accuracy of rotation of adapter and brake drum which it clamps to spindle depends on a close, clean fit.

The taper in the spindle and the taper part of the arbor must be kept absolutely free of any dirt, chips, or foreign matter, otherwise it will run out, and the least inaccuracy here will be multiplied many times on the end of the arbor.

CARE OF ARBOR AND ATTACHMENTS

Arbors, cones, bearing adapters, spacers, bushings, etc. have been machined and ground to the closest possible limits in order to insure the accuracy of work results. They are rugged and will stand up under service, but careless handling and abuse will destroy their accuracy. They must be kept clean, free from grit, chips, etc., not only to insure accuracy in setups, but to avoid damage to the machine itself. Since some of these attachments are machined castings, every precaution should be taken that they are not dropped on concrete floors.

In tightening up assemblies, avoid jerking the wrench, or application of strength greater than necessary to obtain a snug fit.

Keep all attachments clean and coated with a light oil to prevent rusting. The tapered shank of the arbor should be wiped clean and oiled before inserting into the spindle.

Keep all attachments hung on a board or on shelves conveniently located near the machine so that setups can be made quickly and without loss of time. With everything in plain view the selection of proper attachments is a simple matter.

LUBRICATION

DO NOT START THE MOTOR UNTIL YOU HAVE FOLLOWED THESE INSTRUCTIONS ON LUBRICATION.

Correct lubrication will prolong the life and accuracy of any machine tool. This machine is no exception. This modern machine tool combines the highest grade materials with the finest possible skilled workmanship, and the design is based on years of engineering experience, resulting in accuracy and the very latest methods of truing brake drums. These advantages can be destroyed by improper lubrication. Careless or excessive lubrication, however, can be just as injurious as no lubrication at all.

FOLLOW THESE INSTRUCTIONS CAREFULLY:

1. The motor is ball bearing equipped, therefore the bearings will be sealed and no further lubrication is necessary.
2. The front main spindle bearing, a taper roller bearing, is lubricated by means of the Alemite fitting located on the top of the main housing. This bearing should be lubricated every third day of operation with Socony-Vacuum BRB #3 bearing grease or approved equal.
3. The rear main spindle bearing, a taper roller bearing, the worm, the main drive gear, and the worm shaft bearings are all splash lubricated by the lubricant in the main gear box. Socony-Vacuum Mobilube "C" or equal is used. The filler plug is located on the top of the rear cover. The sight gauge on the rear of the lathe is used to measure the amount of oil in the main gear box. The oil should be kept up to the line that is on the gauge and at no time is the lathe to be operated when the oil does not show in the gauge. It must also be remembered that too much oil will cause excessive heat and possible permanent damage.
4. The cross slide and carriage ways are lubricated by applying to the ways Socony-Vacuum Vactra #2 Special, or Vactra Extra Heavy "L" or equal as required to keep carriage feeding smoothly. At the same time dust all chips and dirt from carriage or mating dovetails.
5. All arbors, adapters, cones and spacers should be kept coated with a light film of machine oil when not in use, to prevent rusting or corrosion. If parts are nicked a light pass over the damaged surface with crocus cloth will usually remedy the damage. All parts should mate easily and should not be forced.

ADJUSTMENT OF CARRIAGE AND CROSS SLIDE GIBS

The carriage and cross slide should work on their ways rather snugly, therefore, do not loosen either one to make the unit work more freely. The quality of the work results on this machine depends considerably on the adjustment of these gibs. These gibs may work loose either in transit or during the operation of the lathe and, therefore, it is advisable to make a check before operating the lathe for the first time and at regular intervals of two or three weeks.

When adjusting carriage gib, proceed as follows:

- (1) Loosen each of the four (4) gib screws one half turn.
- (2) Starting with either one of the two middle screws, tighten slowly against the gib, and at the same time, turn the carriage feed handwheel until you feel a slight drag. Keep this drag in mind so that when adjusting the remaining screws, the same tension can be maintained.
- (3) Tighten the other middle screw until the same drag is maintained on the handwheel as was present on the first adjustment.
- (4) Adjust the two remaining screws in the same manner as the first two.
- (5) When all screws have been adjusted, the handwheel should turn with a considerable drag but should not be too difficult to turn.

When adjusting cross slide gibs proceed as follows:

- (1) Loosen each of the four (4) gib screws one half turn.
- (2) Starting with the center screw tighten slowly against the gib, and at the same time turn the cross slide handwheel until you feel a slight drag.
- (3) Make the same adjustment on the other three gib screws maintaining the same drag on the handwheel that was present when the first gib screw was adjusted.
- (4) When all screws have been adjusted, the handwheel should turn with a considerable drag but should not be too difficult to turn.

NOTE:

When adjusting gibs, do not tighten screws excessively. Tighten them only enough so that the slight drag mentioned above can be felt when handwheel is turned.

CARRIAGE FEEDING SYSTEM

The carriage feed is the latest system to be used in Broke Drum Lathe design. If the oil level is maintained it will remain trouble free for many years.

With this type of feeding system there is an advantage of having 8 different feeding speeds, thus being able to control any turning job that may present itself.

The carriage feeding speeds are: .0025" - .005" - .0075" - .010" - .0125" - .015" - .0175" & .020" per spindle revolution. It is recommended that on jobs that appear to warrant excessive amount of stock removal in order to clean up, that it be completed in one cut with the .0025" micro-feed.

The eight feeding speeds are listed on the edge of the dial. To make the feed selection, pull out on the knurled ring and turn it until the index mark on the ring lines up with the desired feed.

INSTALLING AND REMOVING ARBOR

Make certain the taper end of the arbor and the inside of the spindle are clean. To install arbor, simply insert the taper shank into the spindle, being certain to align the matched points on arbor and spindle, and draw it tight by tightening the arbor lock nut.

To remove arbor, loosen arbor lock nut and by doing so the lock nut will act as a puller and loosen the arbor so that it can be pulled out by hand.

MOUNTING THE WORK

With arbor installed in lathe, the drum is now ready to be mounted. Remove the wheel bearings from the hub and wipe the bearing cup clean.

An important factor to be remembered in the setup is to allow for clearance before mounting the drum on the arbor so that it will not be necessary to rehandle it due to lack of clearance or similar reasons.

Various methods to mount the different type drums are listed below.

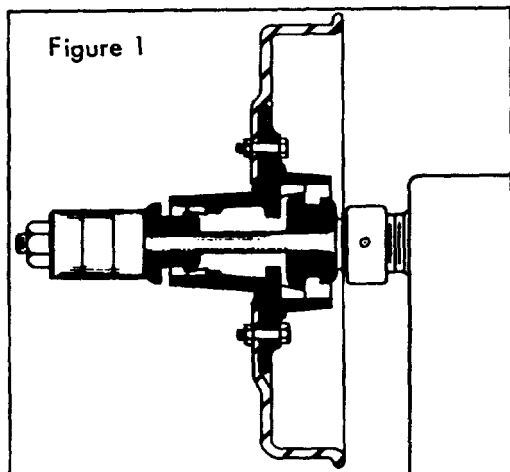

Method #1 On front hubs that are equipped with Timken bearings use the radii adapters as illustrated in fig. 1. When used in Timken bearing equipped hubs the radii adapters make a line contact, providing accurate centering as well as an excellent drive and do not require severe tightening of the arbor nut.

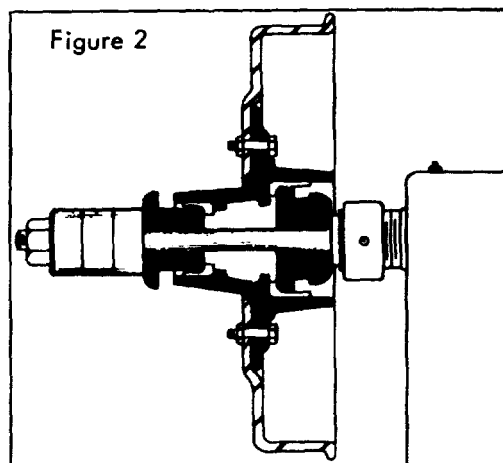

Method #2 On hubs equipped with New Departure ball bearings use the radii adapters as illustrated in fig. 2. Select the radii adapter that fits the bearing cap.

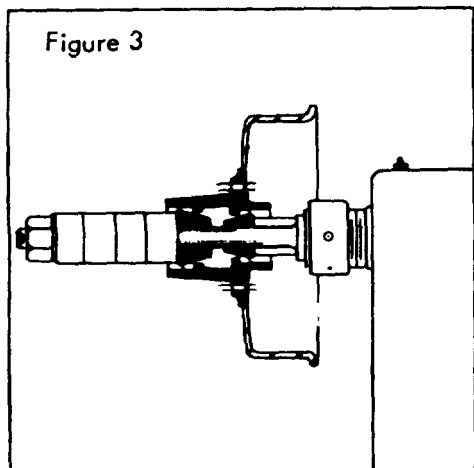

Method #4 Use the taper cones on semifloating or 3/4 floating hub or wheel assemblies as illustrated in fig. 4. Make certain all nicks and burrs in the hub bores are filed down so that assembly will run true.

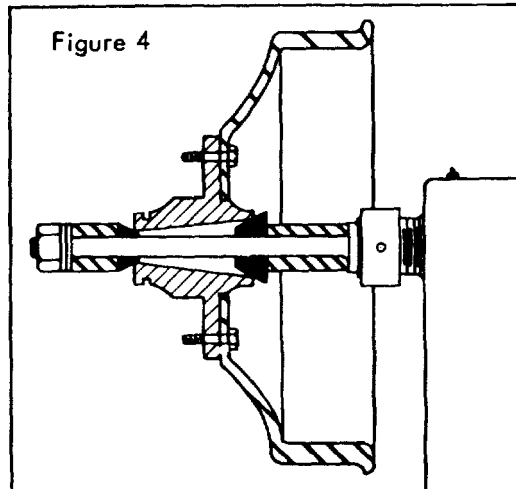

Method #3 On rear hubs equipped with Timken Bearings, use the taper cones illustrated in fig. 3.

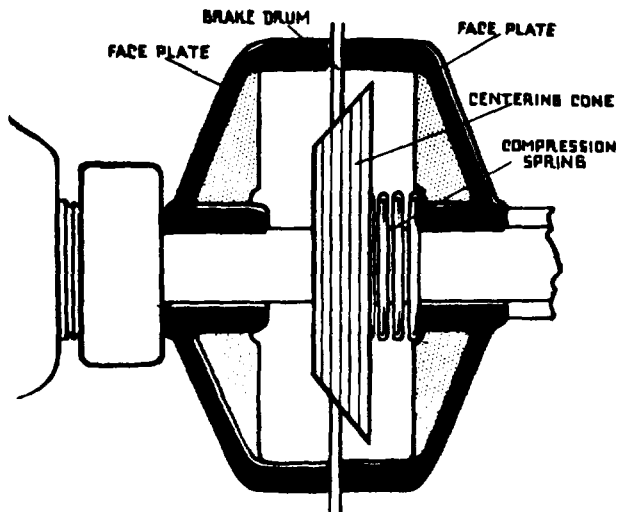

Figure 5

Method 15 On drums that are demountable From the axle shaft flange the floating drum attachment is used. This attachment is standard equipment with the lathe. The attachment consists of 2 face plates, compression spring and centering cones. The 802-2457QS attachment is for passenger cars and light and medium trucks. The installation of the floating drum attachment and drum is made as illustrated in fig. 5.

When necessary to bring the brake drum or tire clear of the machine housing, put a spacer or two on the arbor ahead of the inner adapter or cone. Use enough spacers behind the outer cone or adapter to fill up the arbor. Use only the equipment furnished with the lathe. Makeshift spacers will bend the arbor with the first tightening of the arbor nut due to the fact that the ends of the spacers must be machined perfectly square with the inside bore.

MOUNTING INSTRUCTIONS FOR OUTBOARD SUPPORT

- (A) Bolt lathe to floor.
- (B) Insert 2" arbor into lathe spindle and secure.
- (C) Place complete support unit, including floor plate, under arbor so the 2 roller bearings on support straddle undercut at extreme end of arbor. At the same time position support so indicator faces operator side of lathe.
- (D) Check by sight that support assembly is reasonably perpendicular to floor, and the 2 roller bearings centered at undercut.
- (E) At this point lower rollers by turning knurled knob until support assembly can be removed from floor plate.
- (F) Anchor floor plate to floor with the 3 anchor nuts supplied.
- (G) Place support on floor plate and check alignment between rollers and arbor. If some adjustment must be made, 3 leveling screws with lock nuts are provided, on lower portion of support.

HOW TO SET POSITION INDICATOR

- (A) Raise bearing rollers until each contacts undercut portion of arbor. Turn each roller with your finger until a slight drag is felt.
- (B) With arbor only in lathe, release thumb screw holding position assembly to upper rod and position stem using feeler block between positioning stem and top of lower rod.
- (C) Lower roller assembly until you can again remove complete support off floor plate.
- (D) Mount work on arbor and lock in place.
- (E) Place support back on floor plate and raise rollers until lower rod contacts feeler block and slight drag is felt.

After this preliminary setup, for each job you raise rollers to feeler block. After job is done, lower rollers and remove support, unload finished work, mount next job, raise rollers to feeler block, etc.

TRUING OPERATION

Step 1. A brake drum chatter bond is furnished as standard equipment with the lathe, and is to be used on all drums. Any vibration that might occur due to the brake drum's construction will be dampened by the band. Properly ground tool bits, held to the shortest possible overhang, will prevent any vibration or chatter in the machine.

Step 2. Adjust the tool bar so that enough of it extends out of the tool block to reach the inner edge of the drum when the carriage is to the front of the ways as far as need be. Do not, however, let it extend any further than is necessary, as a short bite affords greater rigidity which assures a better finish.

Step 3. Twist the tool bar so that the point of the tool is slightly above the horizontal center line of rotation. Turning with tool point below center may result in chatter. Do not attempt to set toolbit too far ahead of center, as, with the tool held in the tool bar at a 45° angle, excessive rotation of tool bar will result in practical elimination of the side clearance angle on the tool in its relationship to the work and the tool will then not cut freely.

Step 4. Run the carriage the length of drum surface to be cut, by hand, to make certain there is enough clearance.

Step 5. Set spindle speed to desired RPM. To change belt from one set of pulleys to another, pull belt guard down and lift up on motor. After belt has been placed on desired pulleys, adjust tension in belt by wing nut located on motor mount, until there is about 1" play in belt when thumb pressure is exerted on it.

Step 6. Turn lathe on and run carriage by hand until tool bit lines up with what appears to be the deepest score. Ease tool bit into this score by use of cross feed handwheel, until score appears to have cleaned up. Do not plunge it into drum as the sudden impact may break the toolbit point off. Back the toolbit away from drum approximately one turn and feed carriage into drum until bit reaches inner edge of braking surface.

Step 7. Feed toolbit into drum slowly up to previous reading on dial and lock cross slide with lock provided.

Step 8. Set feeding speed of carriage at desired speed. The condition and composition of drum will determine what is desired feeding speed. Generally speaking, a .005" feeding speed will give good results on drums that require less than .020" cut to clean up and will do so in one pass. A drum that has hard spots, heat checks, or is in such condition that it will require a larger cut than .020" to clean it up will require a carriage feeding speed of .0025". In cases where 2 or more cuts are desirable by the operator, faster speeds are used for a rough cut and either the .005" or .0025" for a finish cut.

Part no.	Quan.	Name
MAIN ASSEMBLY		
802-3004AQS	1	Main assembly
802-3000	1	Main Housing
802-2019A	1	Worm Shaft
HL1418	1	Boston Worm, or Ohio HW1008
KS2028	1	Key
505-2009	1	Bearing Spacer
03162 Cone		
03162 Cone	2	Timken Bearing
505-2007	1	Bearing Shim
505-2008	1	Bearing Cap
802-2008	1	Bearing Cap
1820-12	1	Linear "O" Ring
10-24 x 1/2	8	Flat Head Machine Screw
802-103G	1	Spindle
15200	1	Chicago Rawhide Seal
20094	1	Chicago Rawhide Seal
19150 Cone		
192688 Cup	1	Timken Bearing
16418	1	Chicago Rawhide Seal
11162 Cone		
113008 Cup	1	Timken Bearing
802-2018	1	Carriage Feed Screw Bearing
1743b	3	Alemite Fitting
Lub Seal	3	For Alemite Fitting
802-2039	1	Worm Gear Spool
530-1067B	1	Worm Gear
5/16-18 x 5/8	2	Flat Point Socket Set Screw
KS-2100	1	Key
KS-2108	1	Key
NO7	1	Shaft Lock Nut
W07	1	Shaft Lock Washer
1/4-20 x 1/4	3	Cup Point Socket Set Screw
802-2096B	1	Eccentric Spool
5/16-18 x 1/2	1	Cup Point Socket Set Screw
11-014	8	Linear "O"- Ring
1/4 x 2	1	Rollpin
802-1038	1	Special Shoulder Screw
3/8 x 5/8	1	Stripper Bolt
11-012	8	Linear "O" Ring
802-1047BQS	1	Connecting Rod
868-5	1	Boston Bushing
802-2111	1	Pawl Plate
802-2061	1	Ratchet Pawl
5/16 x 3/8	1	Stripper Bolt
802-2058	1	Pawl Spring
1/8 x 3/4	1	Rollpin
802-2122	1	Ratchet
1/4-20 x 3/8	2	Cup Point Socket Set Screw
#6	1	Woodruff Key
525-2011	2	Feed Screw Snubber
S-10	3	Preload Spring
802-2095AGQS	1	Feed Screw Assembly
802-2114AG	1	Feed Screw
SC62	1	Boston Shaft Collar
3/16x 1-1/8	1	Rollpin
11-111	2	Linear-O" Ring
802-2013	1	Carriage Feed Nut
802-2012	1	Feed Nut Shim
802-2001	1	Special Flat Washer
5/16-18 x 5/8	1	Hex Head Cap Screw
1/8 x 3/8	1	Rollpin
1/8 x 1/2	1	Rollpin
802-38	1	Feed box Cover
802-2014	1	Cover Gasket
5/16-18 x 2	8	Socket Head Cap Screw
85095	1	Bijur" Level type Window
3150x4	1	1/4" Weatherhead Slotted Pipe Plug
322	1	1/2" R.H. Countersunk Pipe Plug
802-2026	1	Breather Plug
TP-3	1	Niagara Shipping Plug
1/8 x 1/2	1	Rollpin
802-2055AQS	1	Feed Cup Assembly
802-2051A	1	Feed Cup
M-1012-B	2	Boston Bushing
11-125	1	Linear "O" Ring
5100-150	2	'Waldes" Snap Ring

Part no.	Quan.	Name
MAIN ASSEMBLY (cont)		
802-2062	1	Feed Index Plate Spring
802-205BQS	1	Feed Index Plate Assembly
802-20508	1	Feed Index Plate
1/8 x 1/2	2	Rollpin
1/8 x 3/8	1	Rollpin
1/8 x 3/8	1	#213 Woodruff Key
802-1037	1	Feed Handwheel
HS-26	1	Handle
#1 x 1-1/4	1	Taper Pin
CARRIAGE ASSEMBLY		
802-22	1	Carriage
1/4-20 x 1	4	Cone Point Socket Set Screw
802-2064	1	Cross Slide Feed Screw Nut
3/16 x 1-1/8	1	Rollpin
802-2010	1	Carriage Gib
802-1006	1	Cross Slide
802-2108	1	Cross Slide Gib
KHS-210	1	Excello Knurled Hoed Screw
1/4-20 x 3/4	3	Cone Point Socket Set Screw
1/4-20	3	Hex Finished Jam Nut
802-2053QS	1	Cross Slide Feed Screw Assembly
802-2000	1	Cross Slide Feed Screw
SC-43	1	Boston Shaft Collar
1/4-20 x 1/4	1	Cup Point Socket Set Screw
3/32 x 7/8	1	Rollpin
3/32 x 5/8	1	Rollpin
1/16 x 1/2	1	#1 Woodruff Key
802-1050A	1	Cross Slide Handwheel
3/8	1	SAE Plain Flat Washer
3/8	1	"Flexlock- Hex Thin Nut
802-2088	1	Cross Feed Washer (Inner)
802-2089	1	Cross Feed Washer (Outer)
DW-2097	1	Tool Block Locking Pin
802-2015	1	Cross Slide Stud
802-1008	1	Tool Bar Holder
3/8-16 x 3/4	2	Square Head Set Screw
1/2	1	SAE Plain Flat Washer
1/2-13	1	Semi Finish Hex Nut 7/8 across flats
3/8-16 x 3/4	1	Dog Point Square Head Set Screw
802-2123	1	Inspection Light Bracket
2761	1	Paulding Porcelain Receptacle
#10 x 3/4	2	Type B Self-tapping Flat Head Screw
10-24 x 1/4	2	Round Head Machine Screw
KD-33	1	SAE A60 Lent Holder
3-3/8 x 3x1/32	1	Cork Gasket
3-1/4 x 1/8	1	Lens
40W 110V AC	1	Light Bulb
802-2022	3	Main Housing Felt Wiper
802-2023	3	Main Housing Wiper Plate
8-32 x 3/8	6	Round Head Machine Screws
#2 x 3/16	4	Type U Drive Screws
SP-715	1	Spindle RPM
SP-710	1	Name Plate
MOTOR DRIVE		
Model BUH	1	Westinghouse Motor 1/2 HP, 1 Ph. 110/220V. AC, B56 Frame, Type FJ 1725 RPM
1/4-20 x 3/4	4	Hex Head Cap Screw
1/4-20	4	Hex Nuts
1/4	4	SAE Plain Flat Washer
1/4	4	Lock Washer
802-2098G	1	3 Step Motor Pulley
2220	2	Gates V" Bolt (includes 1 spare)
802-2097G	1	Worm Pulley
ELECTRICAL EQUIPMENT		
1391	2	Despard Switch
80600	1	H&H Toggle Switch
866	1	Despard Handy Box Cover
5274	1	Hubbell Polarized Plug
5273-L	1	Hubbell Ground Adaptor
3302	2	Cable Connector
14-3	8'	Rubber Cord Wire
14-2	5'6"	Rubber Cord Wire

Part no.	Quan.	Name
ELECTRICAL EQUIPMENT (Cont'd)		
14-1	12"	Stranded Wire
505-1061QS	1	Motor Base Assembly
505-2005	1	Motor Base Shaft
802-1065G	1	Motor Base
505-2170	1	Motor Base Sleeve
3/32 x 1	2	Cotter Pin
505-2017	1	Spring Hanger
3/4x3/8x 1-1/2	1	Lempco Die Spring
3/8-16	1	"Parker,Kolon" Wing Nut
3/8	2	SAE Plain Flat Washer
505-1A	1	Belt Guard
3/16 x 1-3/4	1	Cotter Pin
505-2112	1	Belt Guard Latch
10-24 x 1/4	2	Round Head Machine Screw
DW-2002	1	Dowel Pin

Part no.	Quan.	Name
STANDARD EQUIPMENT (Cont'd)		
802-2458-30G	1	Radii Adopter, 2-1/2 x 2-7/8
802-2458-31G	2	Radii Adapter, 3-1/2 x 3-7/8
802-2458-32G	2	Radii Adapter, 4-1/2 x 5-3/8
802-2458-33G	1	Radii Adapter, 6-1/2 x 7-1/16
802-2458-34G	1	Radii Adopter, 6-1/2 dia.
X-24-4G	1	Spacer
X-24-4H	1	Spacer
X-24-4J	1	Spacer
DH-1030	1	Spacer
DH-1031	1	Spacer
464	1	Armstrong Pin Spanner
DH-204BWR	1	Arbor Wrench
802-2450-17	1	Spanner Wrench
E-1	1	"Perfect" Drum Chatter Eliminator
149	1	Carborundum Pocket Hone
Y-211	2	"Corboly" Tool Sit (RH)
Y-283A	2	High Speed Tool Sit (RH)
802-50QS	1	Cabinet Assembly
505-9QS	1	Cabinet Assembly
505-10	1	Cabinet Body
505-2037	4	Foot Pad
505-2083	As req	Seam Welding Strip
505-2084	1	Cabinet Mount Lug (Rear)
505-2085	1	Cabinet Mounting Lug
505-2086	1	Cabinet Mounting Bar
505-2087	4	Mounting Stud
505-1062	4	Corner Brace
505-3001	1	Cabinet Top
3/8	4	Spring Lock Washer
3/8-16	4	Hex Nut
10-24 x 1/4	4	Round Head Screw
3/8	4	Lock Washers
530-3012GQS	1	Outboard Support
530-3013	1	Base
530-13	1	Base Plate
3/8-16 x 1-1/2	3	Socket Head Cop Screw
1/2-13 x 2-1/2	3	Cone Point Square Head Set Screw
1/2-13	3	Hex Nut
3060	3	Diamond Caulking Anchor Bolts
530-1038	1	Screw
530-2051	1	Adjusting Sleeve
3/8-16 x 1/2	1	Full Dog Socket Set Screw
3/8-16 x 3/4	1	Full Dog Socket Set Screw
3/8-16 x 3/8	2	Flat Point Socket Set Screw
5/16-18 x 3/8	1	Flat Point Socket Set Screw
530-2053	1	Indicating Stem
530-2055	1	Indicator Mounting Rod
530-2056G	1	Indicator Mounting Block
1/4-20 x 1/2	1	Thumb Screw
1/4-20 x 2	1	Positioning Stem
530-2057G	1	Feeler Block
HM-2092	1	Knurled Nut
10-32 x 1/4	1	Dog Point Socket Set Screw
530-1039	1	Bearing Block
530-2052	2	Bearing Shaft
303-SFF	2	MRC Ball Bearing
V4-20 x 3/4	1	Flat Point Socket Set Screw
#4	1	Bulldog Chain, 18" long
10-24 x 1/4	1	Round Head Machine Screw
#10	1	SAE Washer
8-32	1	Hook Screw
2A	1	Brass Plated Ring
5/16-18	1	Hex Jam Nut

STANDARD EQUIPMENT

802-2450GQS	1	Passenger Car & Truck Group
802-2106	1	Boring Bar
505-1500QS	1	Arbor Assembly
505-1002	1	Arbor
505-2034	1	Arbor Lock Nut
505-2035A	1	Arbor Nut
RST-137	1	Retaining Ring
802-2453GQS	1	Cone & Adapter Group
802-2450-3	4	Spacer, 1" Bore x 1" long
802-2450-4	2	Spacer, 11/16" Bore x 1" long
802-2450-5	1	Reducer, 1" OD to 11/16" Bore
802-2450-6	1	Taper Cone, 3/4 to 1-1/2 x, 11/16 Bore
802-2450-7	1	Taper Cone, 1-1/16 to 1-3/4 x 1 Bore
802-2450-8	1	Radii Cone, 1-13/32 x 2-3/8
802-2450-9	1	Radii Cone, 1-19/32 x 1-49/64
802-2450-10	1	Radii Cone, 1-61/64 x 2-13/64
802-2450-11	1	Radii Cone, 2-27/64 x 2-39/64
802-2450-12	1	Radii Cone, 2-19/64x 2-1/2
802-2450-13	1	Radii Cone, 2-35/64 x 2-25/32
802-2450-14	1	Radii Cone, 1-1/2 x 1-45/64
802-2450-15	1	Radii Cone, 1-27/32 x 2-55/64
802-2450-16	1	Radii Cone, 1-1 1/32 x 2-1/16
802-2455GQS	1	Truck Group
802-2455-1	1	Arbor & Lock Nut Assembly
505-1019	1	Arbor, 1"
505-2034	1	Arbor Lock Nut
RST-137	1	Retaining Ring
Y-225A	1	Taper Cone, 2-7/8 x 3-3/8
Y-226	2	Taper Cone, 3-1/4 x 4-1/8
802-2455-4	1	Taper Cone, 3-1/2 x 4-7/8
802-2455-5	1	Taper Cone, 4-1/2 x 6
505-2142	1	Taper Cone, 1-3/8 x 2-1/4
505-2143	1	Taper Cone, 2-1/16 x 2-3/4
Y-135-SD	1	Spacer, 1" ID x 1-1/2" long
802-2455-8	1	Tool Bar
Y-152-5G	1	Arbor Nut
Y-153-5F	1	Arbor Washer
802-2457GQS	1	Floating Drum Attachment
802-2457-1	2	Face Plate
802-2457-2	1	Step Cone
802-2457-3	1	Step Cone
505-2078-1	1	Step Cone
505-2079A1	1	Step Cone
802-2450-20	1	Centering Cone
802-2450-21	1	Centering Cone
802-2450-22	1	Centering Cone
302-2450-26	1	Spring
802-2458GQS	1	Heavy Truck Group
802-1500GQS	1	Arbor Assembly 2"
802-1002G	1	Arbor 2"
802-2034G	1	Arbor Lock Nut
802-2034GA	1	Arbor Lock Nut Plate
DH-2048	1	Arbor Nut
DH-2049	1	Arbor Washer
1/8	1	NPT Hex Socket Pipe Plug
.250x5/8	1	Hard Steel Dowel
Y-131-4A	1	Taper Cone
Y-132-48	1	Taper Cone

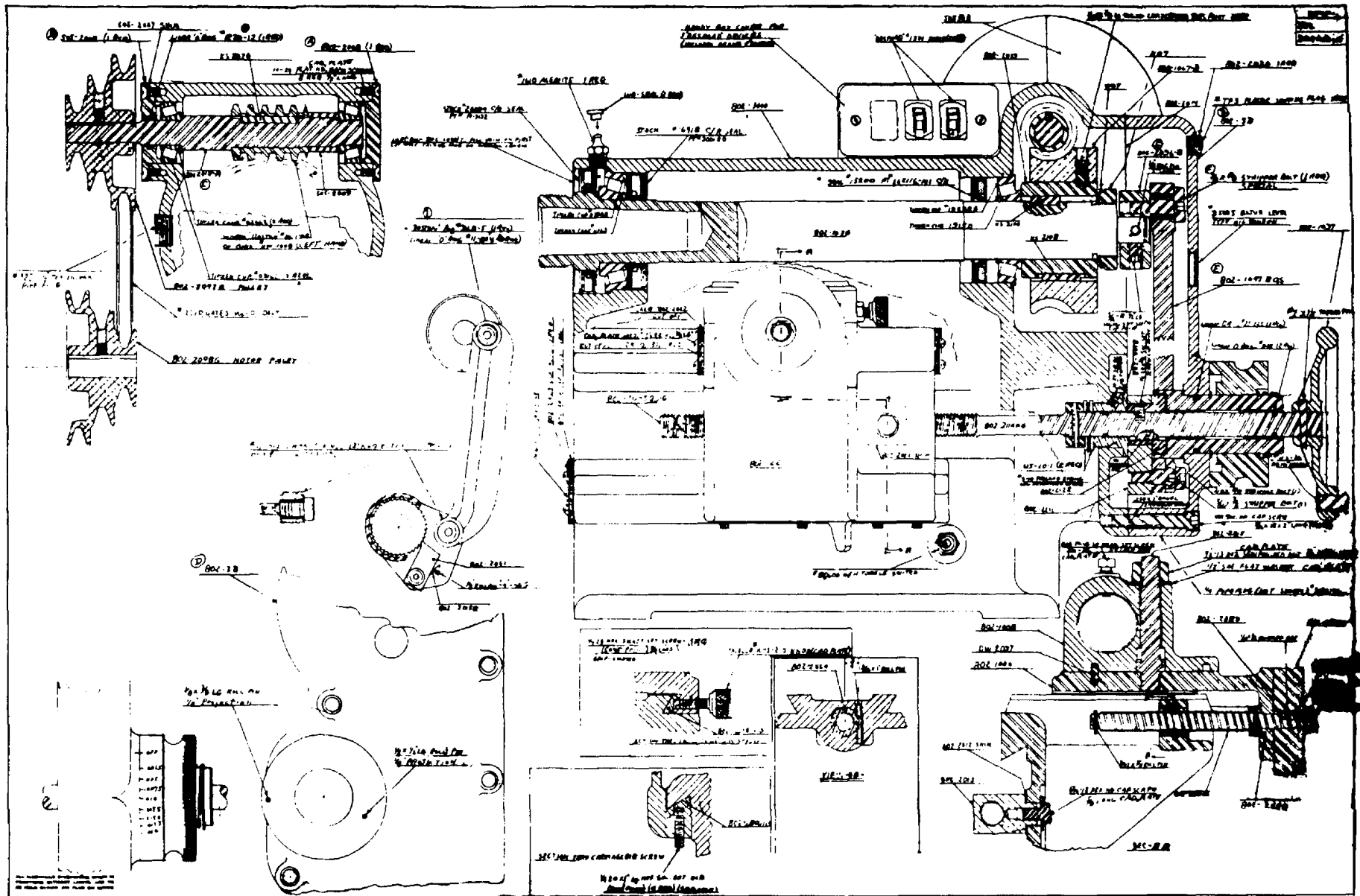

Figure 7

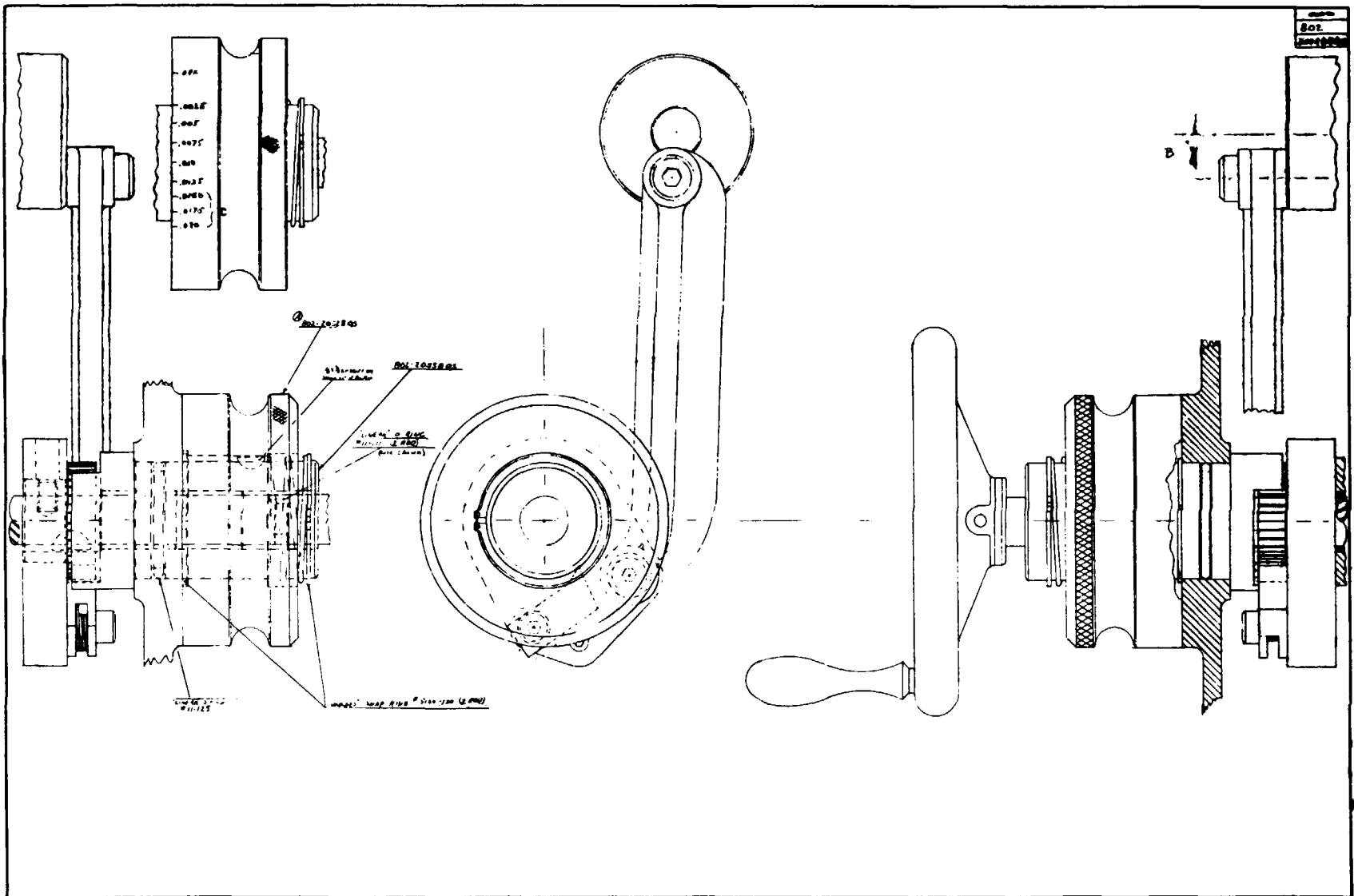
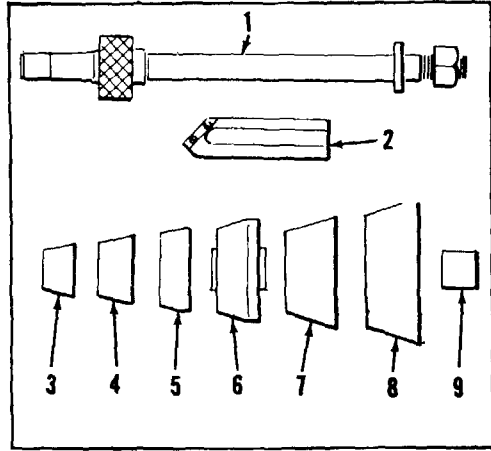
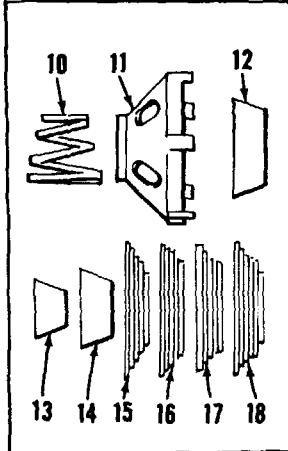

Figure 8



TRUCK GROUP



FLOATING DRUM ATTACHMENT

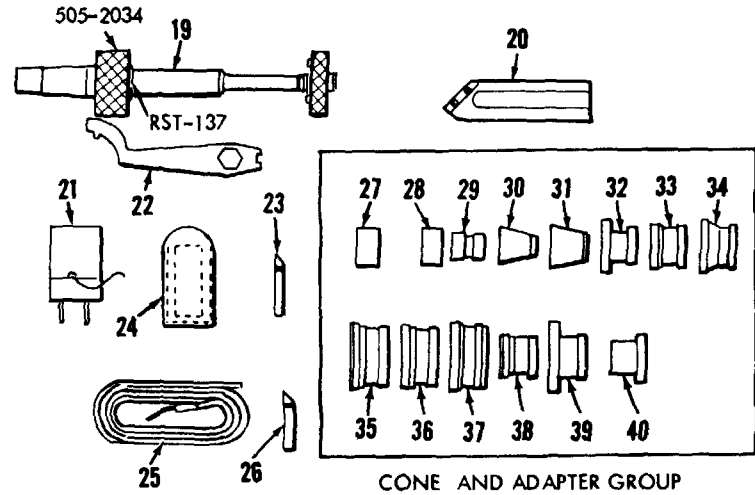

CONE AND ADAPTER GROUP

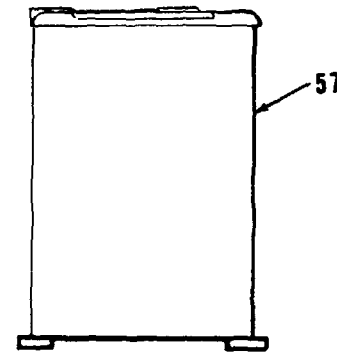
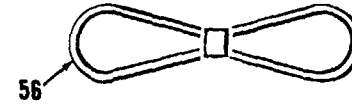
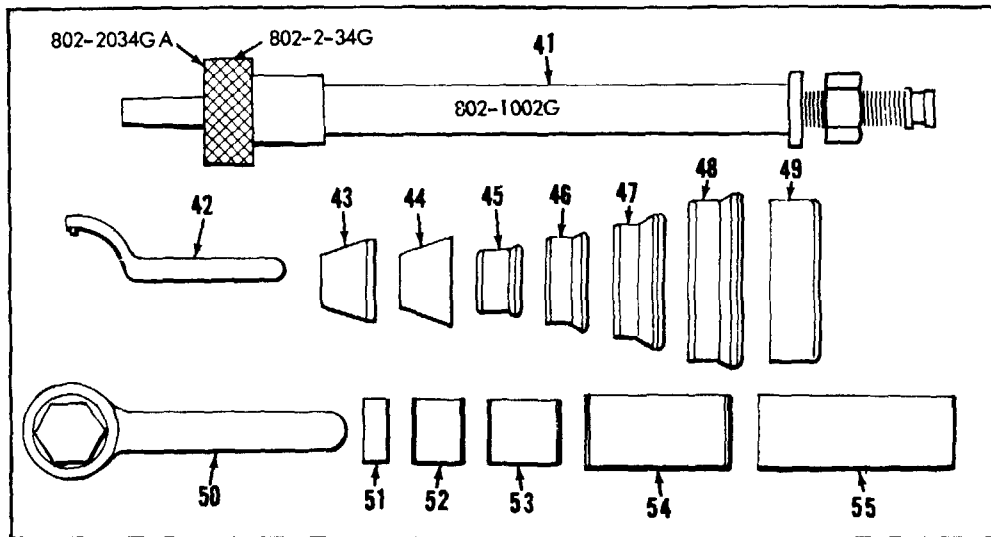

CABINET ASSEMBLY

**APPENDIX
BASIC ISSUE ITEMS LIST**

Section I. PREFACE

1. General

This appendix is a list of basic issue items. It is composed of those items which make up the major end item of equipment and the operator's tools, equipment, and repair parts that are issued with the equipment and are required for stockage.

2. Requisitioning a Part to Which FSN Has Not Been Assigned

When requisitioning a C source (local procurement) item identified only by a manufacturer's part number, it is mandatory that the following information be furnished the supply officer:

a. Manufacturer's code number (5-digit No. preceding the colon in the descriptive column).

b. Manufacturer's part number (the number, and sometimes letters, following the colon, (1) above). Dashes, commas, or other marks must be included exactly as listed.

c. Nomenclature exactly as listed herein, including dimensions, if necessary.

d. Name of manufacturer of end item (from cover of TM or manufacturer's nameplate).

e. Federal stock number of end item (from TM).

f. Manufacturer's model number (from TM or name/data plate, preferably name/data plate).

g. Manufacturer's serial number (from name/data plate).

h. Any other information such as type, frame number, and electrical characteristics, if applicable.

i. If DD Form 1348 (DOD Single Line Items Requisition System Document (Manual)) is used, fill in all blocks except 4f 5, 6, and Remarks field, in accordance with AR 72550.

Complete form as follows:

- (1) In blocks 4, 5, and 6, list manufacturer's code, and manufacturer's part number (as listed in description colm).
- (2) In Remarks field, list name (repair part), end item application (FSN of end item), manufacturer, model number (end item), serial number (end item), and any other pertinent information such as frame number, type, etc.

3. Explanation of Columns

a. *Source, Maintenance, and Recoverability Code* (colm 1).

(1) Materiel numerical codes (colm 1a). This column is not required.

(2) Source (colm 1b). This column indicates the selection status and source for the listed item. Source code used in this list is -

<i>Code</i>	<i>Explanation</i>
C	Obtain through local procurement. If not obtainable from local procurement, requisition through normal supply channels with a supporting statement of nonavailability from local procurement.

(3) Maintenance level (colm 1c). This column indicates the category of maintenance authorized to install the listed item. Maintenance level code used in this list is-

<i>Code</i>	<i>Explanation</i>
O/C	Operator or crew maintenance.

(4) Recoverability (colm 1d). This column indicates whether unserviceable items should be returned for recovery or salvage. When no code is indicated, the item will be considered expendable. Recoverability code used in this list is-

<i>Code</i>	<i>Explanation</i>
R	Items which are economically repairable at direct and general support maintenance activities and normally are furnished by supply on an exchange basis.

b. Federal Stock Number (colm 2). Self explanatory.

c. Description (colm 3). Self-explanatory. Listed below are manufacturers' codes included in this column.

Code	Explanation
03914.....	Armstrong Bros. Tool Co.
24161.....	Gates Rubber Co.
35719.....	Lempco Products, Inc.

d. Unit of Issue (colm 4), Quantity Authorized (colm 5), and Illustration (colm 6). Self explanatory.

4. Abbreviations

Abbreviation	Explanation
amp.....	ampere(s)
circ.....	circumference
deg.....	degree(s)
fl.....	flat
HSS	high speed steel
rh.....	right hand
term.....	terminal(s)
v.....	volts(s)
w/	with

5. Errors, Comments, and/or Suggestions

Reports by the individual user of errors, comments, and suggestions are encouraged. They should be reported on DA Form 2028 (Recommended Changes to DA Publications) and forwarded directly to Commanding General, Headquarters, U.S. Army Weapons Command, ATTN: AMSWVE-SMM-P, Rock Island Arsenal, Rock Island, IL 61202.

Section II. BASIC ISSUE ITEMS

(1) Source maintenance, and recoverability code				(2) Federal stock No.	(3) Description	(4) Unit of Issue	(5) Qty authorized	(6) Illustration	
(a) Material code	(b) Source	(c) Maint. level	(d) Recoverability					(a) Fig No.	(b) Item No.
			R	4910-516-6192	<p>MAJOR COMBINATION</p> <p>The following item is to be requisitioned for initial issue only.</p> <p>LATHE, BRAKE DRUM: (35719:802)</p>	ea		6 and 10	
	C	O/C		3030-236-7942	<p>COMPONENTS OF MAJOR COMBINATION</p> <p>None authorized</p> <p>REPAIR PARTS FOR:</p> <p>LATHE, BRAKE DRUM: (35719:802)</p> <p>BELT, V: rubberized fabric, 22 in. outside circ, 1/2 in. top w, 40 deg angle (24161:2220).</p>	ea	1	10	56
	C	O/C		5935-545-3886	<p>TOOLS AND EQUIPMENT FOR:</p> <p>LATHE, BRAKE DRUM: (35719:802)</p> <p>ADAPTER, CONNECTOR: dielectric, 2 fl parallel male contacts and grounding lead w/term. one end, 2 fl parallel and 1 U female contacts other end, ac/dc, 125-v, 16 amp (74545:5273L).</p>	ea	1	10	21
	C	O/C			ADAPTER, RADII: 2 1/2 x 2 7/8 (35719:802-2458-30G)	ea	1	10	45
	C	O/C			ADAPTER, RADII: 3 1/1 x 3 7/8 (35719:802-2458-31G)	ea	2	10	46
	C	O/C			ADAPTER, RADII: 4 1/2 x 5 3/8 (35719:802-2458-32G)	ea	2	10	47
	C	O/C			ADAPTER, RADII: 6 1/2 (35719:802-2458-34G)	ea	1	10	49
	C	O/C			ADAPTER, RADII: 6 1/2 x 7 1/2 (35719:802-2458-3G)	ea	1	10	48
	C	O/C			ARBOR ASSEMBLY: 1 in. (35719:802-2455-1)	ea	1	10	1
	C	O/C			ARBOR ASSEMBLY: 2 in. (35719:802-1500QOS)	ea	1	10	41
	C	O/C			ARBOR ASSEMBLY: shoulder, 1 in. and 11/16 dia. (35719 :505-1500QS).	ea	1	10	19
	C	O/C			BAR, BORING: (35719:802-2106) -.	ea	1	10	20
	C	O/C			BAR, TOOL: (35719:802-2455-8)	ea	1	10	2
	C	O/C			BIT, TOOL: carboloy, rh (35719:Y-211)	ea	2	10	28
	C	O/C			BIT, TOOL: HSS, rh (35719:Y-283A)	ea	2	10	26

Section II. BASIC ISSUE ITEMS-Continued

(1) Source maintenance, and recoverability code				(2) Federal stock No.	(3) Description	(4) Unit of Issue	(5) Qty authorized	(6) Illustration	
(a) Material code	(b) Source	(c) Maint. level	(d) Recoverability					(a) Fig No.	(b) Item No.
	C	O/C		5345-575-0676	CABINET ASSEMBLY: (35719:802-501QS)	ea	1	10	57
	C	O/C			CHATTER ELIMINATOR, DRUM: (35719:E-1)	ea	1	10	25
	C	O/C			CONE, CENTERING: (35719:802-2450-20)	ea	1	10	13
	C	O/C			CONE, CENTERING: (35719:802-2450-21)	ea	1	10	14
	C	O/C			CONE, CENTERING: (35719:802-2450-22)	ea	1	10	12
	C	O/C			CONE, RADII: 1 11/32 x 2 2/16 (35719:802-2450-16)	ea	1	10	40
	C	O/C			CONE, RADII: 1 13/13 x 2 3/8 (35719:802-2450-8)	ea	1	10	32
	C	O/C			CONE, RADII: 1 1/2 X 1 45/64 (35719:802-2450-14)	ea	1	10	38
	C	O/C			CONE, RADII: 1 19/32 X 14 49/64 (35719:802-2450-9)	ea	1	10	33
	C	O/C			CONE, RADII: 1 27/32 x 2 55/64 (35719:802-2450-15)	ea	1	10	39
	C	O/C			CONE, RADII: 1 61/64 x 2 13/64 (35719:802-2450-10)	ea	1	10	34
	C	O/C			CONE, RADII: 2 19/64 x 2 1/2 (35719:802-2450-12)	ea	1	10	36
	C	O/C			CONE, RADII: 2 27/64 X 2 39/64 (35719 :802-2450-11)	ea	1	10	35
	C	O/C			CONE, RADII: 2 35/64 x 2 25/32(35719:802-2450-13)	ea	1	10	37
	C	O/C			CONE, STEP: (35719:505-2078-1)	ea	1	10	16
	C	O/C			CONE, STEP: (35719:505-2079A1)	ea	1	10	15
	C	O/C			CONE, STEP: (35719:802-2457-2)	ea	1	10	18
	C	O/C			CONE, STEP: (35719:802-2457-3)	ea	1	10	17
	C	O/C			CONE, TAPER: (35719:Y-131-4A)	ea	1	10	43
	C	O/C			CONE, TAPER: (35719:Y-132-4B)	ea	1	10	44
	C	O/C			CONE, TAPER: 3/4 to 1 1/2, x 11/16 bore (35719:802-2450-6)	ea	1	10	30
	C	O/C			CONE, TAPER: 1 1/16 to 1 3/4 x 11/16 bore (35719: 802-2450-7)	ea	1	10	31
	C	O/C			CONE, TAPER: 1 3/8 x 2 1/4 (35719:505-2142)	ea	1	10	3
	C	O/C			CONE, TAPER: 2 1/16 x 2 3/4 (35719:505-2143)	ea	1	10	4
	C	O/C			CONE, TAPER: 2 7/8 x 3 3/8 (35719:Y-225A)	ea	1	10	5
	C	O/C			CONE, TAPER: 3 1/4 x 4 1/8 (35719:Y-226)	ea	2	10	6
	C	O/C			CONE, TAPER: 3 1/2 x 4 7/8 (35719:802-2455-4)	ea	1	10	7
	C	O/C			CONE, TAPER: 4 1/2 x 6 (35719:802-2455-5)	ea	1	10	8
	C	O/C			HONE, SHARPENING: carborundum (35719:149)	ea	1	10	24
	C	O/C			PLATE, FACE: (35719:802-2457-1)	ea	2	10	11
	C	O/C		REDUCER, ARBOR: 1 od to 11/16 bore (35719:802-245-5)	ea	1	10	29	
	C	O/C		SPACER, ARBOR: (35719:DH-1030).	ea	1	10	54	
	C	O/C		SPACER, ARBOR: (35719:DH-1031)	ea	1	10	55	

C	O/C		SPACER, ARBOR: (35719:X-24-4G)	ea	1	10	51
C	O/C		SPACER, ARBOR: (35719:X-24-4H)	ea	1	10	52
C	O/C		SPACER, ARBOR: (35719:X-24-4J)	ea	1	10	53
C	O/C		SPACER, ARBOR: 1; bore, 1 lg (35719:802-2450-4)	ea	2	10	28
C	O/C		SPACER, ARBOR: 1 bore, 1 lg (35719:802-2450-3)	ea	4	10	27
C	O/C		SPACER, ARBOR: 1 bore, 1 1/2 lg (35719:Y-135-5D)	ea	1	10	9
C	O/C		SPRING, FACE PLATE: coil (35719:802-2450-26)	ea	1	10	10
C	O/C		SUPPORT, OUTBOARD: (35719:530-3012GQS)	ea	1	10	58
C	O/C		WRENCH, ARBOR: (35719:DH-2048WR)	ea	1	10	50
C	O/C		WRENCH, SPANNER: (03914-464)	ea	1	10	42
C	O/C		WRENCH, SPANNER: (35719:802-2450-17)	ea	1	10	22

Figure 10. Repair parts tools, and equipment.

RECOMMENDED CHANGES TO EQUIPMENT TECHNICAL PUBLICATIONS

 <p><i>THEN...JOT DOWN THE DOPE ABOUT IT ON THIS FORM. CAREFULLY TEAR IT OUT, FOLD IT AND DROP IT IN THE MAIL.</i></p>		SOMETHING WRONG WITH PUBLICATION	
		FROM: (PRINT YOUR UNIT'S COMPLETE ADDRESS)	
PUBLICATION NUMBER		PUBLICATION DATE	PUBLICATION TITLE
DATE SENT			
BE EXACT PIN-POINT WHERE IT IS			
PAGE NO.	PARA-GRAPH	FIGURE NO.	TABLE NO.
IN THIS SPACE, TELL WHAT IS WRONG AND WHAT SHOULD BE DONE ABOUT IT.			
PRINTED NAME, GRADE OR TITLE AND TELEPHONE NUMBER			SIGN HERE

DA FORM 1 JUL 79 2028-2

PREVIOUS EDITIONS ARE OBSOLETE.

P.S.--IF YOUR OUTFIT WANTS TO KNOW ABOUT YOUR RECOMMENDATION MAKE A CARBON COPY OF THIS AND GIVE IT TO YOUR HEADQUARTERS.

The Metric System and Equivalents

Linear Measure

1 centimeter = 10 millimeters = .39 inch
 1 decimeter = 10 centimeters = 3.94 inches
 1 meter = 10 decimeters = 39.37 inches
 1 dekameter = 10 meters = 32.8 feet
 1 hectometer = 10 dekameters = 328.08 feet
 1 kilometer = 10 hectometers = 3,280.8 feet

Weights

1 centigram = 10 milligrams = .15 grain
 1 decigram = 10 centigrams = 1.54 grains
 1 gram = 10 decigrams = .035 ounce
 1 decagram = 10 grams = .35 ounce
 1 hectogram = 10 decagrams = 3.52 ounces
 1 kilogram = 10 hectograms = 2.2 pounds
 1 quintal = 100 kilograms = 220.46 pounds
 1 metric ton = 10 quintals = 1.1 short tons

Liquid Measure

1 centiliter = 10 milliliters = .34 fl. ounce
 1 deciliter = 10 centiliters = 3.38 fl. ounces
 1 liter = 10 deciliters = 33.81 fl. ounces
 1 dekaliter = 10 liters = 2.64 gallons
 1 hectoliter = 10 dekaliters = 26.42 gallons
 1 kiloliter = 10 hectoliters = 264.18 gallons

Square Measure

1 sq. centimeter = 100 sq. millimeters = .155 sq. inch
 1 sq. decimeter = 100 sq. centimeters = 15.5 sq. inches
 1 sq. meter (centare) = 100 sq. decimeters = 10.76 sq. feet
 1 sq. dekameter (are) = 100 sq. meters = 1,076.4 sq. feet
 1 sq. hectometer (hectare) = 100 sq. dekameters = 2.47 acres
 1 sq. kilometer = 100 sq. hectometers = .386 sq. mile

Cubic Measure

1 cu. centimeter = 1000 cu. millimeters = .06 cu. inch
 1 cu. decimeter = 1000 cu. centimeters = 61.02 cu. inches
 1 cu. meter = 1000 cu. decimeters = 35.31 cu. feet

Approximate Conversion Factors

<i>To change</i>	<i>To</i>	<i>Multiply by</i>	<i>To change</i>	<i>To</i>	<i>Multiply by</i>
inches	centimeters	2.540	ounce-inches	Newton-meters	.007062
feet	meters	.305	centimeters	inches	.394
yards	meters	.914	meters	feet	3.280
miles	kilometers	1.609	meters	yards	1.094
square inches	square centimeters	6.451	kilometers	miles	.621
square feet	square meters	.093	square centimeters	square inches	.155
square yards	square meters	.836	square meters	square feet	10.764
square miles	square kilometers	2.590	square meters	square yards	1.196
acres	square hectometers	.405	square kilometers	square miles	.386
cubic feet	cubic meters	.028	square hectometers	acres	2.471
cubic yards	cubic meters	.765	cubic meters	cubic feet	35.315
fluid ounces	milliliters	29.573	cubic meters	cubic yards	1.308
pints	liters	.473	milliliters	fluid ounces	.034
quarts	liters	.946	liters	pints	2.113
gallons	liters	3.785	liters	quarts	1.057
ounces	grams	28.349	liters	gallons	.264
pounds	kilograms	.454	grams	ounces	.035
short tons	metric tons	.907	kilograms	pounds	2.205
pound-feet	Newton-meters	1.356	metric tons	short tons	1.102
pound-inches	Newton-meters	.11296			

Temperature (Exact)

°F	Fahrenheit temperature	5/9 (after subtracting 32)	Celsius temperature	°C
----	---------------------------	-------------------------------	------------------------	----

This fine document...

Was brought to you by me:



[Liberated Manuals -- free army and government manuals](#)

Why do I do it? I am tired of sleazy CD-ROM sellers, who take publicly available information, slap “watermarks” and other junk on it, and sell it. Those masters of search engine manipulation make sure that their sites that sell free information, come up first in search engines. They did not create it... They did not even scan it... Why should they get your money? Why are not letting you give those free manuals to your friends?

I am setting this document FREE. This document was made by the US Government and is NOT protected by Copyright. Feel free to share, republish, sell and so on.

I am not asking you for donations, fees or handouts. If you can, please provide a link to liberatedmanuals.com, so that free manuals come up first in search engines:

<A HREF=<http://www.liberatedmanuals.com/>>Free Military and Government Manuals

- Sincerely
Igor Chudov
<http://igor.chudov.com/>
- [Chicago Machinery Movers](#)