Table of Contents

Subject	Page
MS42/MS432
Objectives of the Module2
Purpose of the System3
System Components4
Power Supply7
Principle of Operation8
Workshop Hints9
Tools and Equipment10
Air Management11
Principle of Operation20
Workshop Hints28
Tools and Equipment31
Fuel Management32
Principle of Operation39
Workshop Hints45
Tools and Equipment52
Ignition Management55
Principle of Operation62
Workshop Hints66
Tools and Equipment72
Emissions Management74
Evaporative Emissions74
Exhaust Emissions78
Principle of Operation84
Workshop Hints.104
Tools and Equipment107
Performance Controls109
ECM Programming.117
Tools and Equipment118
Review Questions119

MS42/MS43

**Models: E46/E39/Z3 - MS42 with M52TU Engine
E46/E39/Z3/E53 - MS43 with M54 Engine**

**Production Date: MS42 1998 - 2000
MS43 2001 MY to Present**

Manufacturer: Siemens

Pin Connector: 134 Pins - 5 Modular Connectors

Objectives of the Module

After completing this module, you will be able to:

- Describe the Power Supply for the Fuel Injectors and Ignition Coils
- Understand the MDK/EDK and Idle Air Actuator Operation
- Name the Differences Between the MS42/MS43 Fuel Supply System
- List the Inputs Required for Fuel Injector Operation
- Describe Emission Optimized Function
- Name the Two Types of Emissions the ECM Controls
- Explain Why Two Sensors are Used to Monitor Accelerator Pedal Movement
- Understand LDP and DM TL Evaporative Leak Testing
- Describe How the Ignition System is Monitored

MS42/MS43

Purpose of the System

The MS42/MS43 systems manage the following functions:

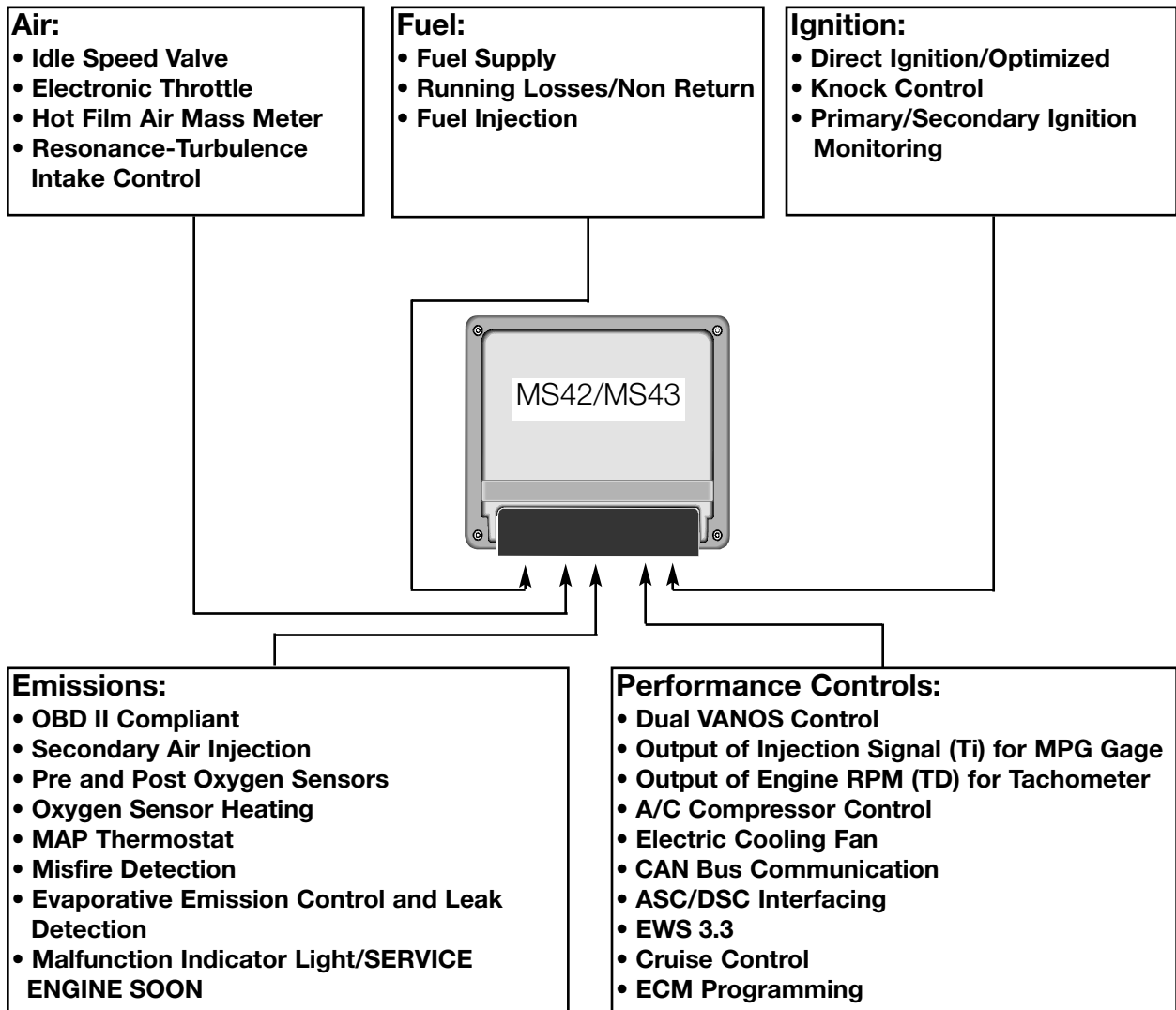

System Components

MS42/MS43 Engine Control Module: The Engine Control Module (ECM) features a single printed circuit board with two 32-bit microprocessors.

The task of the first processor is to control:

• Engine Load
• Electronic Throttle
• Idle Actuator
• Ignition
• Knock Control



12550000.tiff

The task of the second processor is to control:

• Air / Fuel Mixture
• Emission Control
• Misfire Detection
• Evaporative Leak Detection

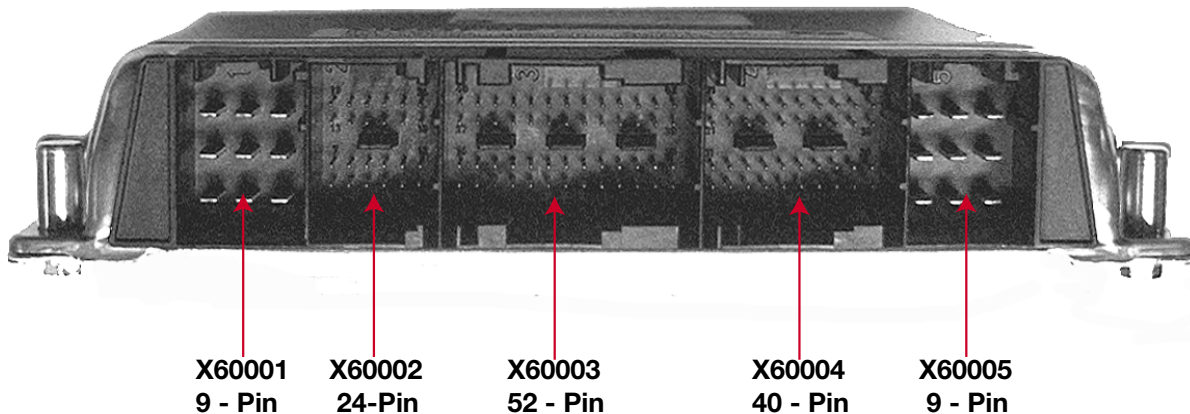

The 134 pin ECM is manufactured by Siemens to BMW specifications. The ECM is the SKE (standard shell construction) housing and uses 5 modular connectors. For testing, use the Universal Adapter Set (break-out box) Special Tool # 90 88 6 121 300.

System Components: Inputs - Processing - Outputs

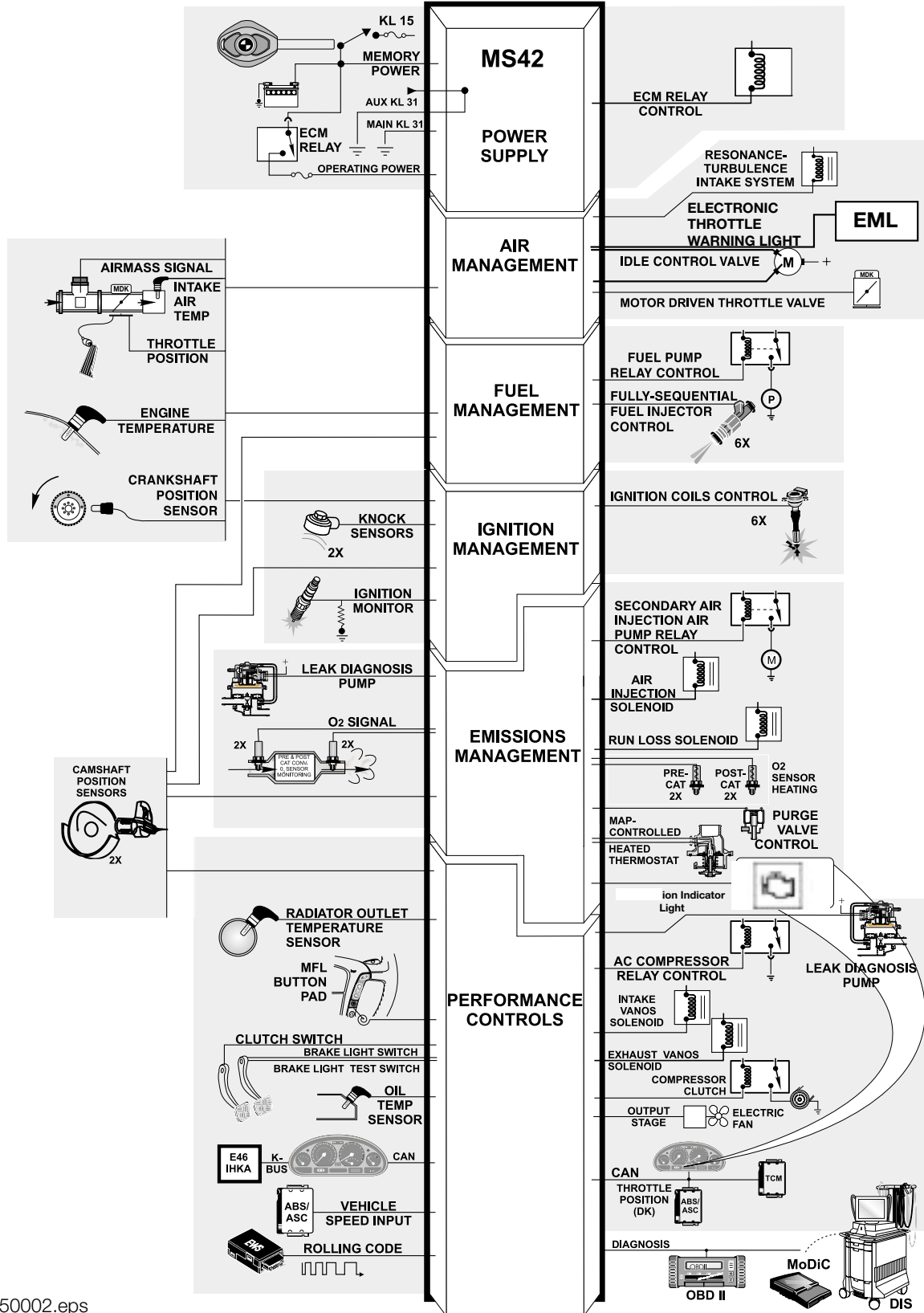

12550002.eps

System Components: Inputs - Processing - Outputs

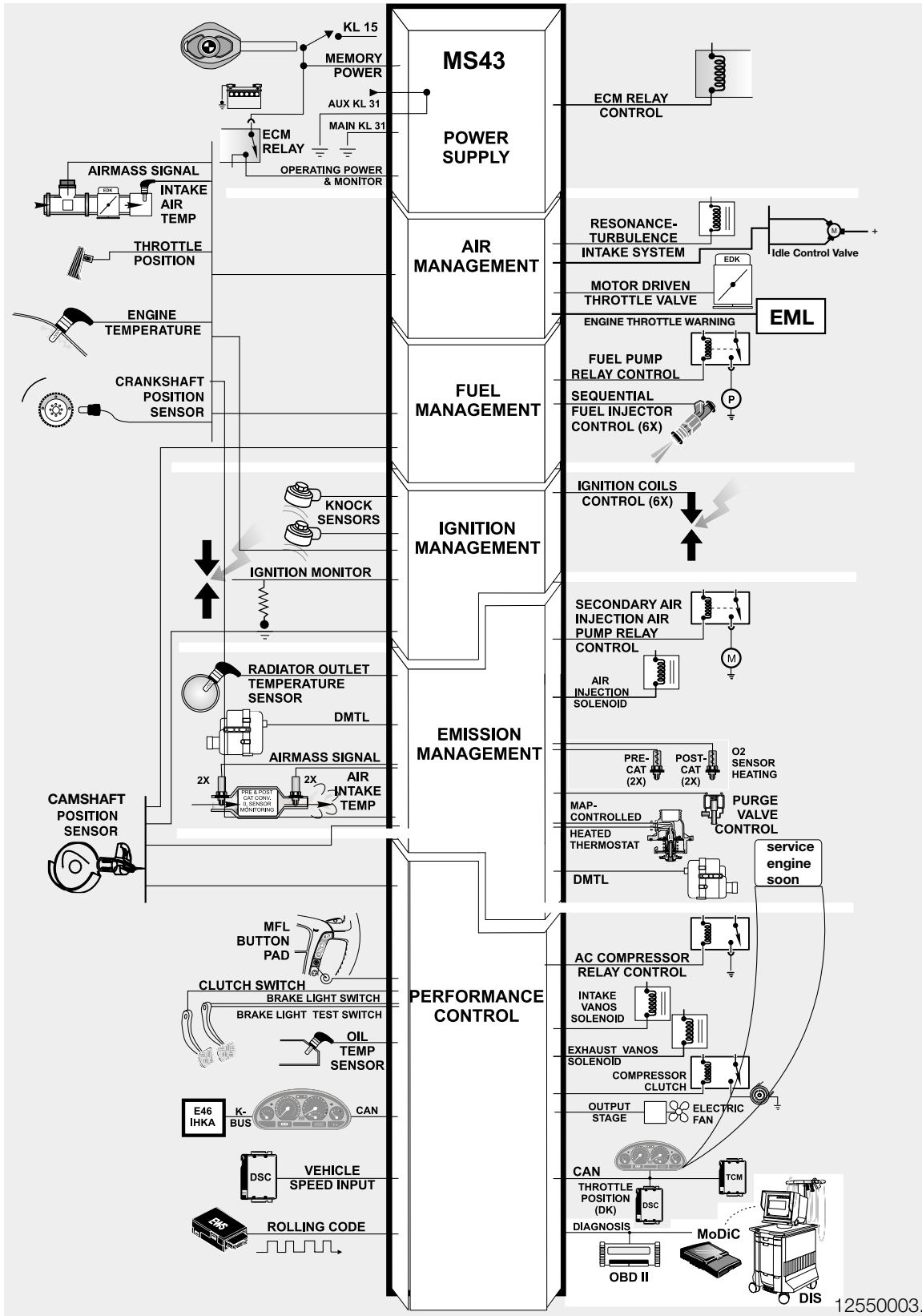

12550003.eps

Power Supply

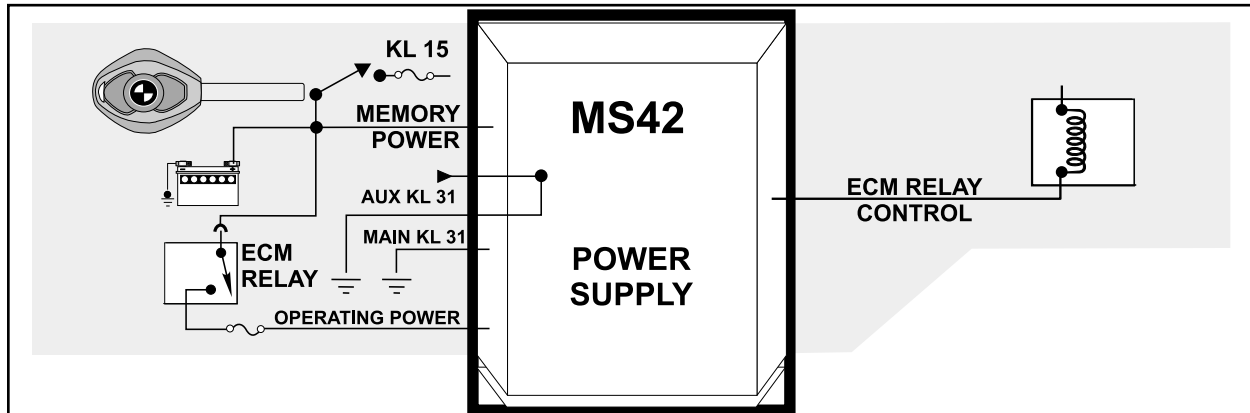

KL30 - Battery Voltage: B+ is the main supply of operating voltage to the ECM.

Power Supplies: The power supplies (KL15 and ECM Relay) are fused to the MS42/MS43 ECM. The fuses are housed in the Engine Fuse Block located in the Electronics Box.

KL15 - Ignition Switch: When the ignition is switched “on” the ECM is informed that the engine is about to be started. KL15 (fused) supplies voltage to the Engine Control Module Relay and the Fuel Injector Relay. Switching KL15 “off” removes the ECM operating voltage.

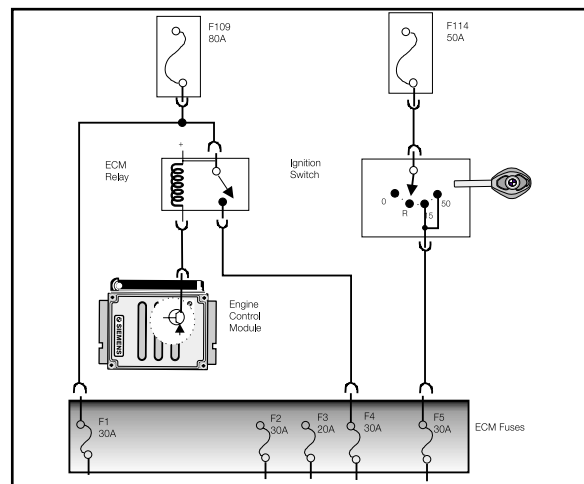

13410062.eps

Engine Control Module Relay: The ECM Relay provides the operating voltage for:

1. ECM	6. Ignition Coils
2. Fuel Injection	7. Evaporative Leak Detection Pump
3. Idle Air Actuator	8. Camshaft Sensors
4. Evaporative Emission Valve	9. Hot Film Air Mass
5. Fuel Pump Relay	10. Oxygen Sensor Heaters

Ground: Multiple ground paths are necessary to complete current flow through the ECM. The ECM ground pin numbers are:

Connector X60001	Connector X60005
Pin 4 - Ground for ECM	Pin 5 - Ground for ECM
Pin 5 - Ground for ECM	Pin 6 - Ground for ECM (MS42)
Pin 6 - Ground for ECM	

Principle of Operation

Battery Voltage is monitored by the ECM for fluctuations. It will adjust the output functions to compensate for a lower (6v) and higher (14v) voltage value. For example, the ECM will:

- **Modify pulse width duration of fuel injection.**
- **Modify dwell time of igniton**

When **KL15** is switched “on” the ECM is ready for engine management. The ECM will activate ground to energize the Engine Control Module Relay. The Engine Control Module Relay supplies operating voltage to the ECM and the previously mentioned operating components. MS43 - Five seconds after the ignition is switched on and the voltage at the KL15 input is >9 volts, the ECM compares the voltage to the ECM Relay supplied voltage. If the voltage difference between the two terminals is greater than 3 volts, a fault code will be set.

When **KL15** is switched “off” the ECM operating voltage is removed. The ECM will maintain a ground to the Engine Control Module Relay for a few seconds to maintain ignition coil activation (MS43 Emission Optimized).

Ground is required to complete the current path through the ECM. The ECM also:

- **Internally links a constant ground (1) to the Engine Sensors.**
- **Switches ground (2) to activate components.**

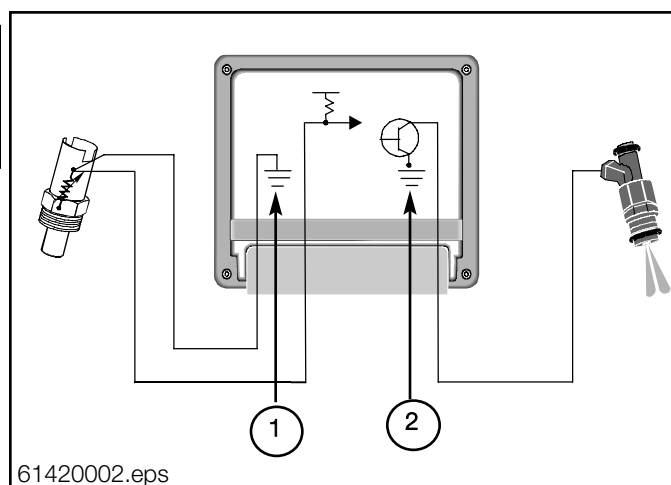

Workshop Hints

Power Supply - Testing

Inadequate power and ground supply can result in:

1.	No Start
2.	Hard Starting (Long Crank Times)
3.	Inaccurate Diagnostic Status or ECM (Not Found)
4.	Intermittant/Constant "ENGINE EMISSION/EML" Light
5.	Intermittant/Constant Driveability Problems

Power supply including fuses should be tested for:

1.	Visual (1) Blown Fuse
2.	Available Voltage (2)
3.	Voltage Drop (Dynamic Resistance) (2)
4.	Resistance of Cables and Wires (2)

The ignition (KL15) must be switched off when removing or installing the ECM connector to prevent voltage spikes (arcing) that can damage the Control Module!

The Engine Control Module Relay (located in the Electronics Box) should be tested for:

1.	Battery Voltage and Switched Ground (1)
2.	Resistance (1)
3.	Battery Voltage and Voltage Drop (2)

E46 Electronics Box - ECM and Fuses



12550007.tiff

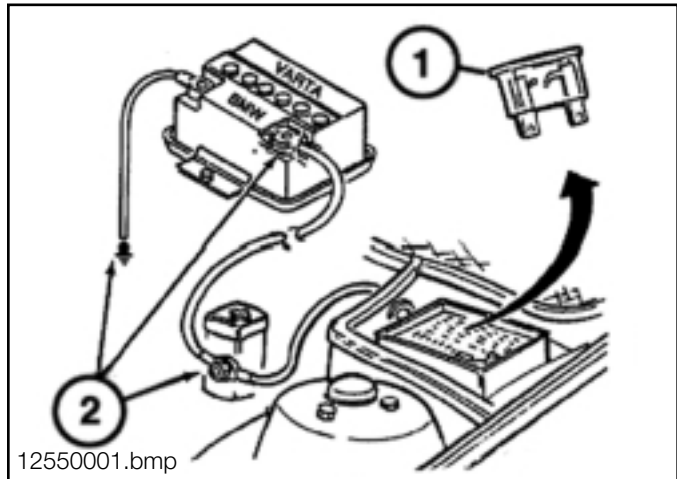

12550001.bmp

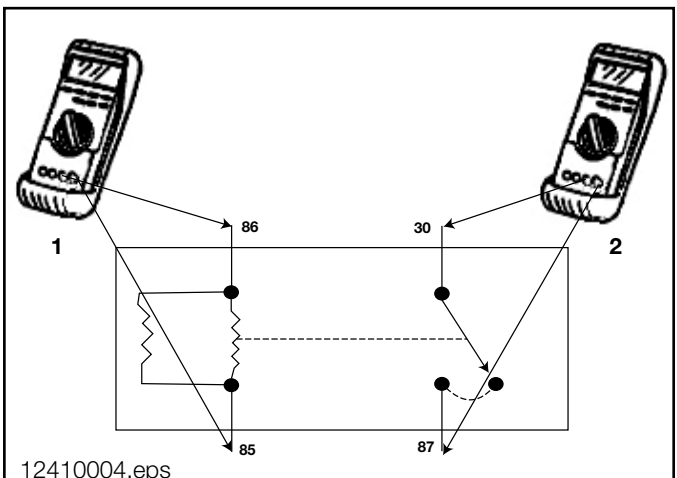
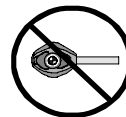

12410004.eps

Tools and Equipment

Power Supply

When testing power supply to an ECM, the DIS/MoDIC multimeter function as well as a reputable hand held multimeter can be used.

It is best to make the checks at the ECM connection, this method includes testing the wiring harness.

The correct Universal Adapter for the MS42/MS43 application should be used (#90 88 6 121 300). This will ensure the pin connectors and the harness will not be damaged.

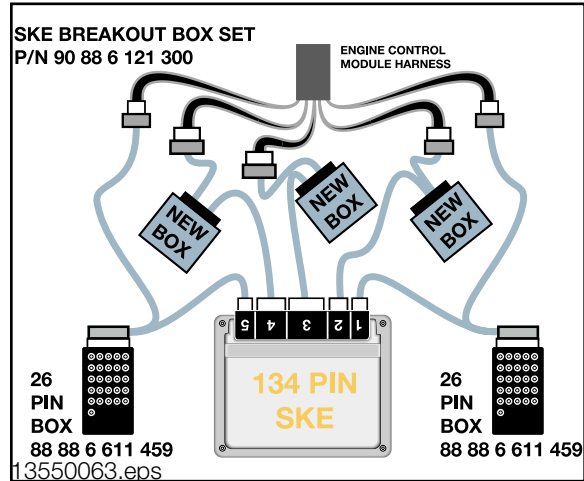

12550003.tiff

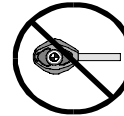

When installing the Universal Adapter to the ECM (located in the Electronics Box in the engine compartment), make sure the ignition is switched off.

The Engine Control Module **Relay** should be tested using the relay test kit (P/N 88 88 6 613 010) shown on the right.

This kit allows testing of relays from a remote position.

Always consult the ETM for proper relay connections.

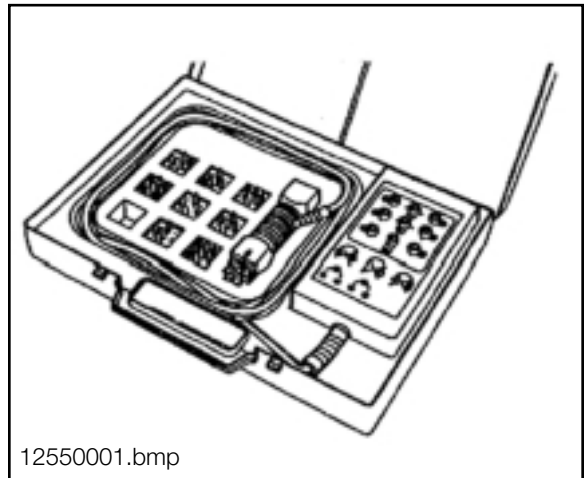

12550001.bmp

Air Management

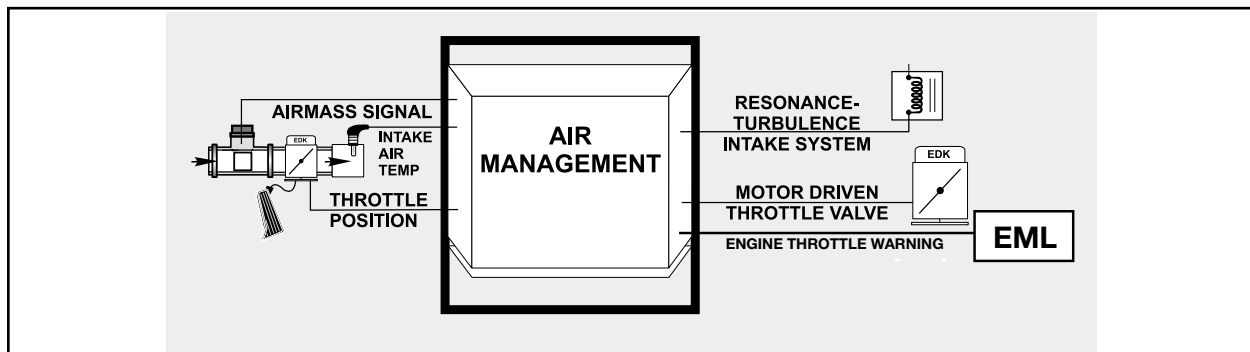

Throttle Valve: The throttle valve plate is electronically operated to regulate intake air flow by the ECM. The purpose is for precision throttle operation, OBD II compliant for fault monitoring, ASC/DSC and cruise control. This integrated electronic throttle reduces extra control modules, wiring, and sensors. **Adjusting electronic throttles is not permitted, the throttle assembly must be replaced as a unit. The adaptation values must be cleared and adaptation procedure must be performed using the DISplus/MoDIC.**

The throttle assembly for the **MS42** system is referred to as the **MDK** (Motor Driven Throttle Valve). The MDK is distinguished by:

- The accelerator position potentiometers (PWG = driver's wish) are integrated in the MDK housing.
- A throttle cable is used to actuate the accelerator pedal position potentiometers and also serves as a backup to open the throttle plate (full control) if the MDK system is in failsafe.

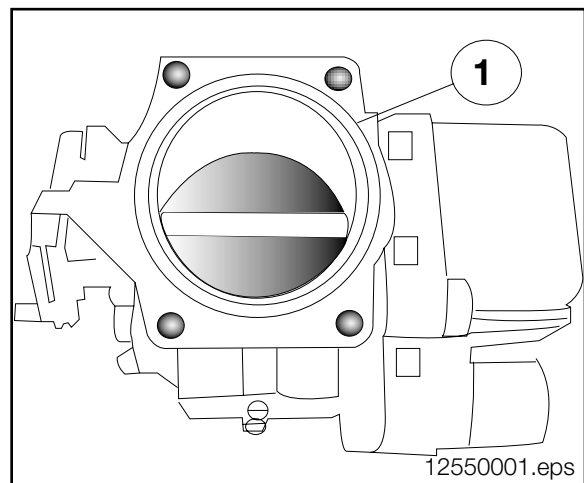

The throttle assembly for the **MS43** system is referred to as the **EDK**. The EDK is distinguished by:

- EDK does not contain a PWG, It is remotely mounted (integrated in the accelerator pedal assembly).
- The accelerator pedal is not mechanically "linked" to the EDK



Throttle Position Sensor

MDK: The throttle cable (foot pedal controlled) is connected to a pulley on the side of the MDK. The pulley is linked by springs to one end of the throttle shaft (springs also return the accelerator pedal to the rest position).

With the pulley linked by springs to the throttle shaft, this allows ASC intervention to override the driver's set throttle position.

As the pulley and shaft are rotated, the dual potentiometers (integral in the MDK housing = driver's wish) monitor the requested load for the ECM. Dual potentiometers are used for request plausibility.

EDK: The accelerator pedal module provides two variable voltage signals to the ECM that represents accelerator pedal position and rate of movement. Dual Hall Sensors are integral in the accelerator pedal module. The ECM compares the two values for plausibility. The module contains internal springs to return the accelerator pedal to the rest position.

The ECM provides voltage (5v) and ground for the Hall sensors. As the accelerator pedal is moved from rest to full throttle, the sensors produce a variable voltage signal.

Hall sensor 1 (request) = 0.5 to 4.5 volts
 Hall sensor 2 (plausibility) = 0.5 to 2.0 volts

If the signals are not plausible, the ECM will use the lower of the two signals as the requested input. The throttle response will be slower and the maximum throttle response will be reduced.

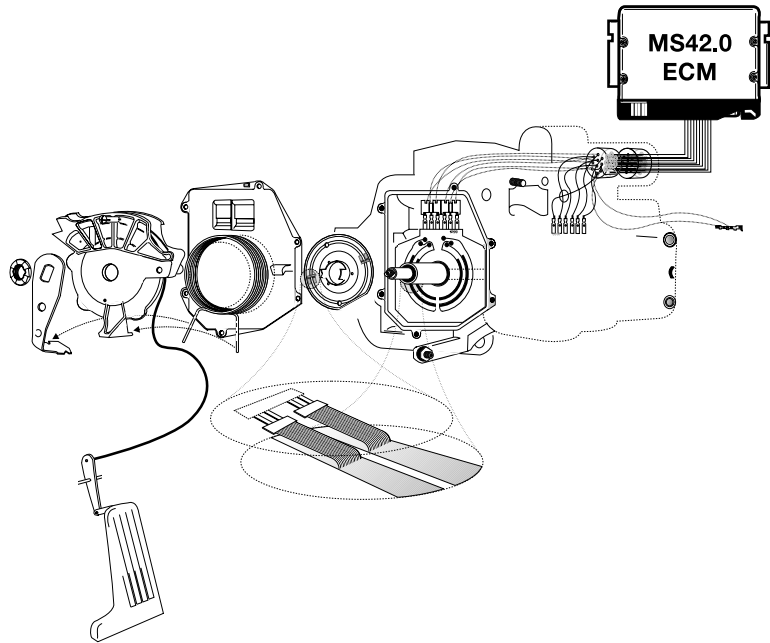

13550003.eps

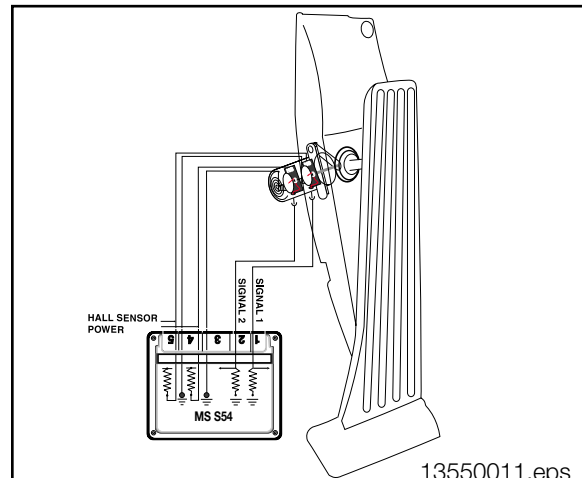

13550011.eps

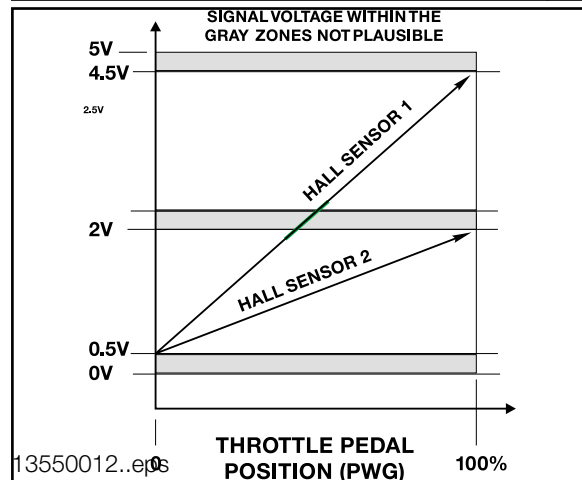

13550012..eps

Throttle Motor and Feedback Position

MDK: The MS42 ECM powers the MDK motor using pulse width modulation for opening and closing at a basic frequency of 600 Hz which positions the throttle plate. The throttle plate is also closed by an integrated return spring.

Dual potentiometers feedback the actual throttle plate position, allowing the ECM to verify correct throttle position. Dual potentiometers are used for feedback plausibility.

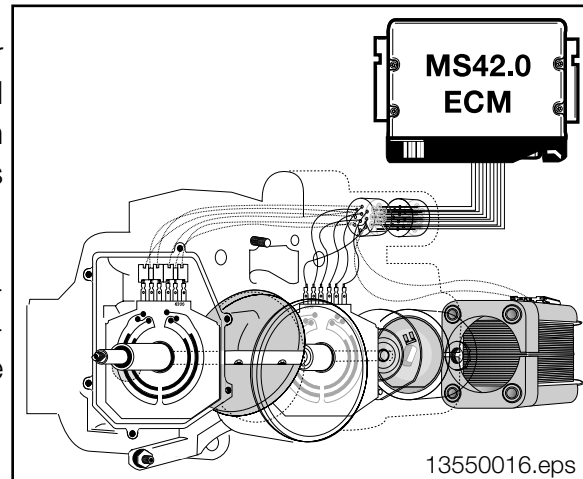

EDK: The MS43 ECM powers the EDK motor using pulse width modulation for opening and closing the throttle plate. The throttle plate is also closed by an integrated return spring.

Two integrated potentiometers provide voltage feedback signals to the ECM as the throttle plate is opened and closed.

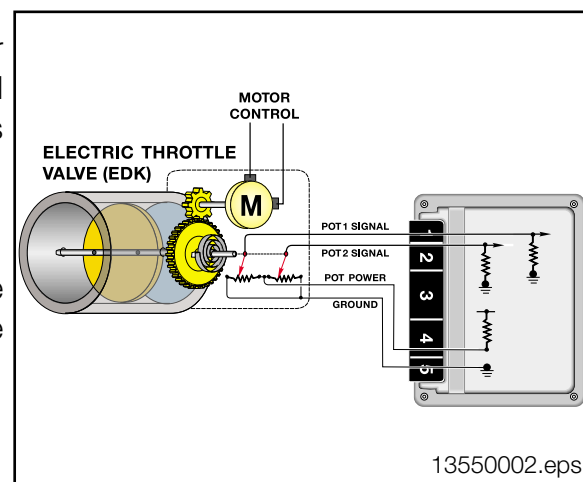

- Feedback signal 1 provides a signal from 0.5v (closed) to 4.5 V (full throttle).
- Feedback signal 2 provides a signal from 4.5v (closed) to 0.5 V (Full Throttle).

Potentiometer 1 is the primary feedback signal of throttle plate position and signal 2 is the plausibility cross check through the complete throttle plate movement.

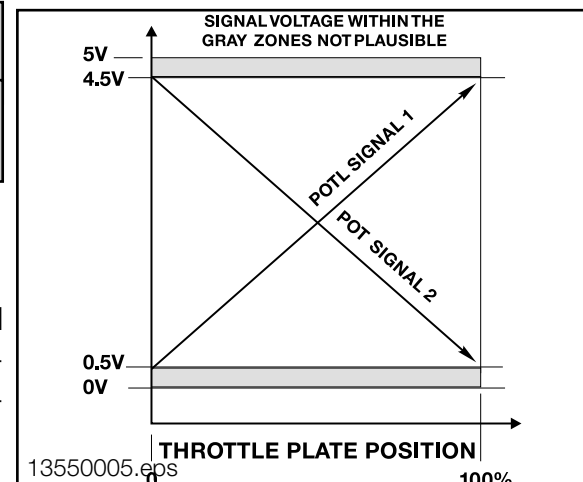

Idle Air Actuator: This valve regulates air by-passing the throttle valve to control the engine idle/low speed.

The valve is supplied with battery voltage from the ECM Relay. The Idle Air Actuator is a two-coil rotary actuator. The ECM is equipped with two final stage transistors which will alternate positioning of the actuator.

The final stages are "pulsed" simultaneously by the ECM which provides ground paths for the actuator. The duty cycle of each circuit is varied to achieve the required idle RPM.

If this component/circuits are defective, a fault code will be set and the "Malfunction Indicator Light" will be illuminated when the OBD II criteria is achieved.

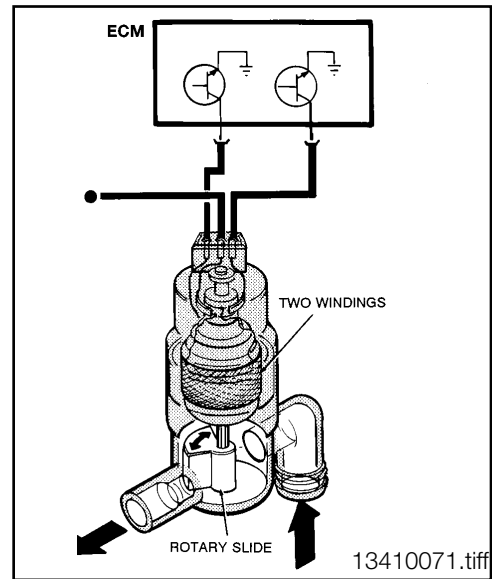

Hot-Film Air Mass Meter (HFM): The air volume input signal is produced electronically by the HFM which uses a heated metal film (180° C above intake air temperature) in the air flow stream.

The ECM Relay provides the operating voltage. As air flows through the HFM, the film is cooled changing the resistance which affects current flow through the circuit. The sensor produces a 1-5 volt varying signal. Based on this change the ECM monitors and regulates the amount of injected fuel.

If this input is defective, a fault code will be set and the "Malfunction Indicator Light" will be illuminated when the OBD II criteria is achieved. The ECM will operate the engine using the Throttle Position and Engine RPM inputs.

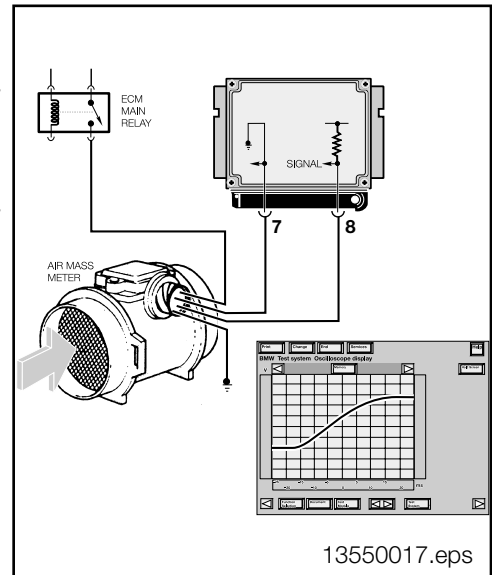

NOTE: The Siemens 2 Type B designation simply indicates that the sensor is smaller in design. The mass air meter has different diameters based on engine application. The HFM is non-adjustable.



13550004.tiff

Air Temperature Signal: This signal is needed by the ECM to correct the air volume input for changes in the intake air temperature affecting the amount of fuel injected, ignition timing and Secondary Air Injection activation. The sensor is located in the center of the intake manifold (1).

The ECM provides the operating voltage (5v) to this sensor. The sensor decreases in resistance as the intake air temperature rises and vice versa (NTC). The ECM monitors the voltage signal that varies (0-5v) as the resistance changes.

If this input is defective, a fault code will be set and the "Malfunction Indicator Light" will be illuminated when the OBD II criteria is achieved. The ECM will operate the engine using the Engine Coolant Sensor input as a back up.

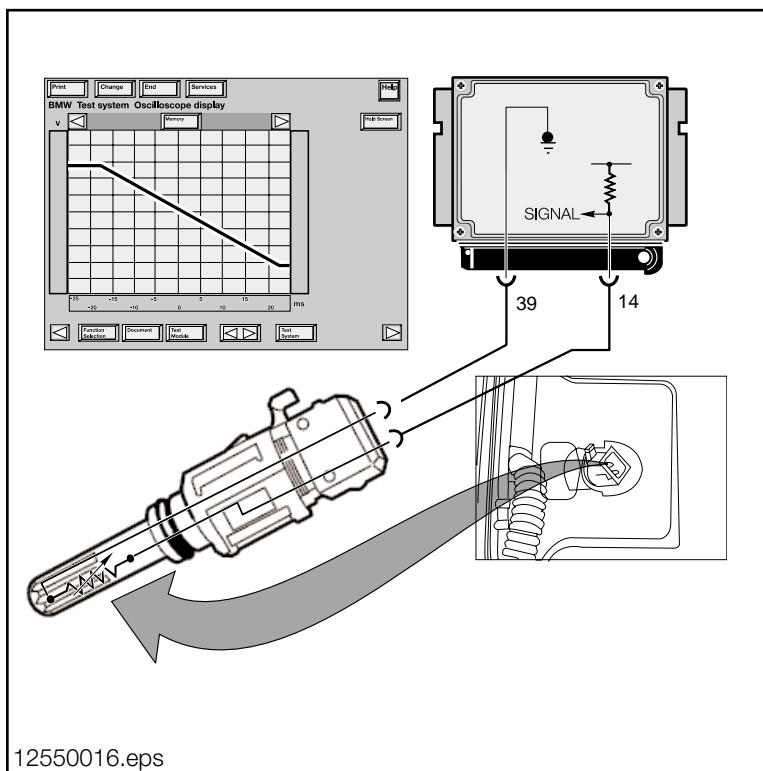

Resonance/Turbulence Intake System: On the M52TU and M54, the intake manifold is split into two groups of three (runners) which increases low end torque. The intake manifold also has separate (internal) turbulence bores which channels air from the idle speed actuator directly to one intake valve of each cylinder (matching bore of 5.5mm in the cylinder head).

Routing the intake air to only one intake valve causes the intake to swirl in the cylinder. Together with the high flow rate of the intake air due to the small intake cross sections, this results in a reduction in fluctuations and more stable combustion.

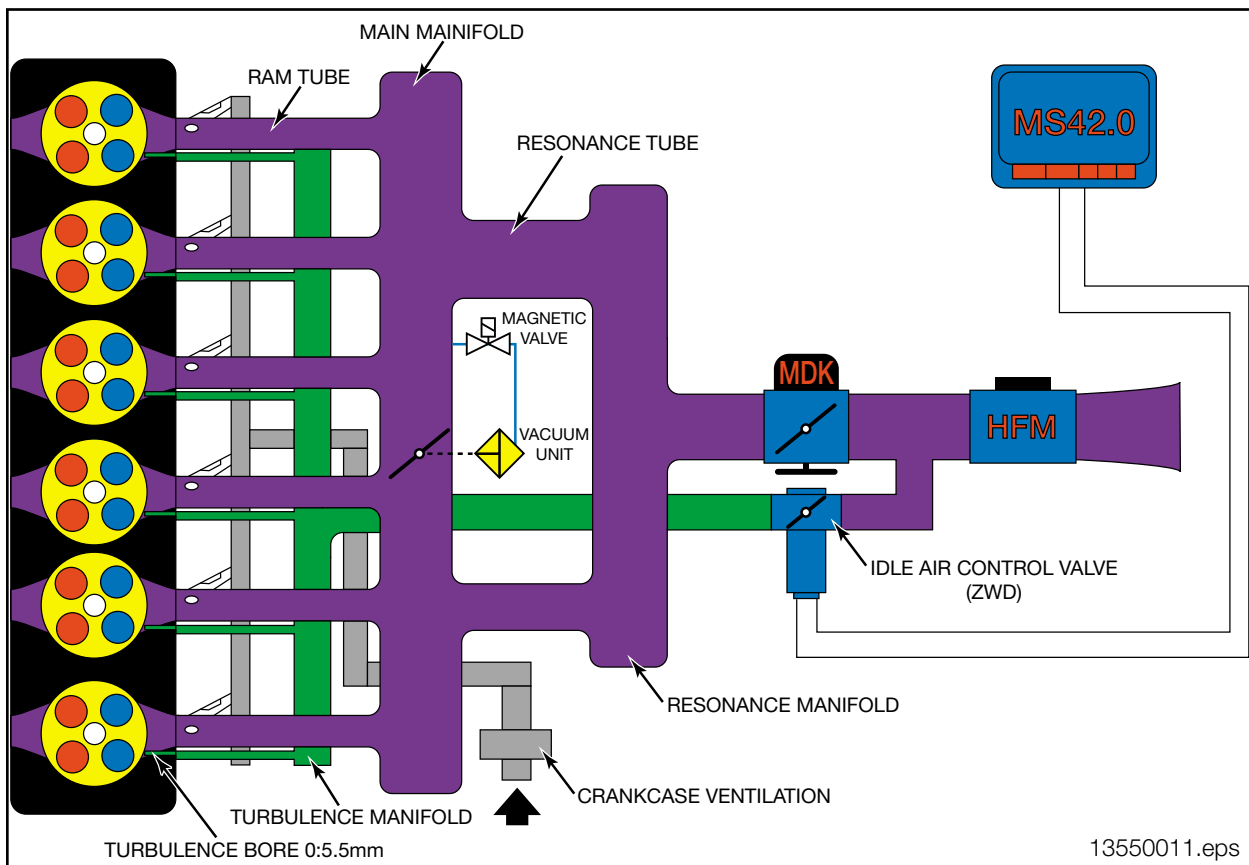

Resonance System: The resonance system provides increased engine torque at low RPM, as well as additional power at high RPM. Both of these features are obtained by using an ECM controlled resonance flap (in the intake manifold).

During the low to mid range rpm, the resonance flap is closed. This produces a long/single intake tube which increases engine torque.

During mid range to high rpm, the resonance flap is open. This allows the intake air to draw through both resonance tubes, providing the air volume necessary for additional power at the upper RPM range.

The Resonance Flap (shown on the right) is closed when vacuum is applied and sprung open. This is a unitized assembly that is bolted into the intake manifold.



The ECM controls a solenoid valve for resonance flap activation. At speeds below 3750 RPM, the solenoid valve is energized and vacuum supplied from an accumulator closes the resonance flap. This channels the intake air through one resonance tube, but increases the intake velocity.

When the engine speed is greater than 3750 RPM (which varies slightly - temperature influenced), the solenoid is de-energized. The resonance flap is sprung open, allowing flow through both resonance tubes, increasing volume.

When the flap is closed, this creates another “dynamic” effect.

• # 1 Cylinder Intake Valve open Low to Mid Range RPM (<3750 RPM)

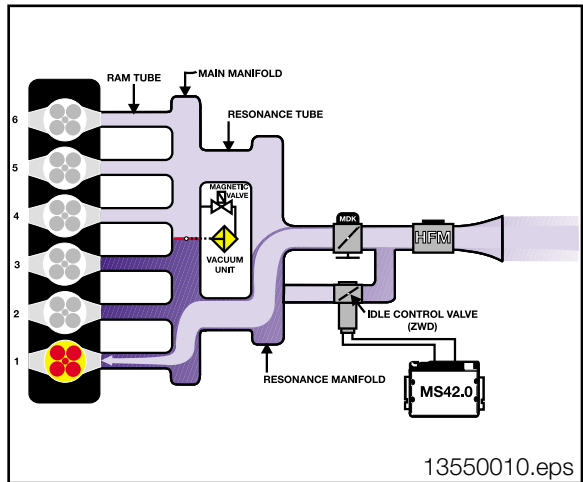

As the intake air is flowing into cylinder #1, the intake valves will close.

This creates a “block” for the in rushing air. The air flow will stop and expand back (resonance wave back pulse) with the in rushing air to cylinder #5.

• #1 Cylinder Intake Valve closes #5 Intake Valve Open => Intake Air Bounce Effect Low to Mid Range RPM (<3750 RPM).

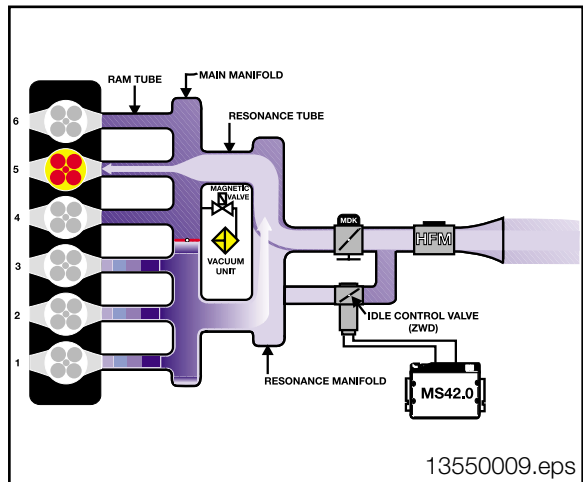

The resonance “wave”, along with the intake velocity, enhances cylinder filling.

When the engine speed is greater than 3750 RPM the solenoid is de-energized. The resonance flap is sprung open, allowing flow through both resonance tubes, increasing volume.

• #1 Cylinder Intake Valve Open - Intake air drawn from both resonance tubes. Mid to High Range RPM (>3750 RPM)

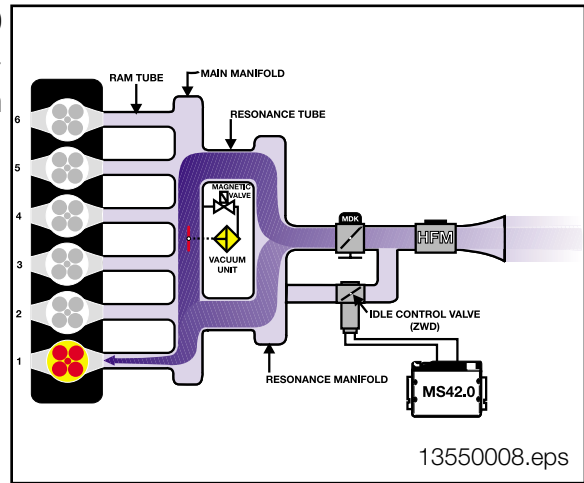

• #5 Cylinder Intake Valve Open - Intake air drawn from both resonance tubes. Mid to High Range RPM (>3750 RPM).

The resonance “wave”, along with the intake volume, enhances cylinder filling.

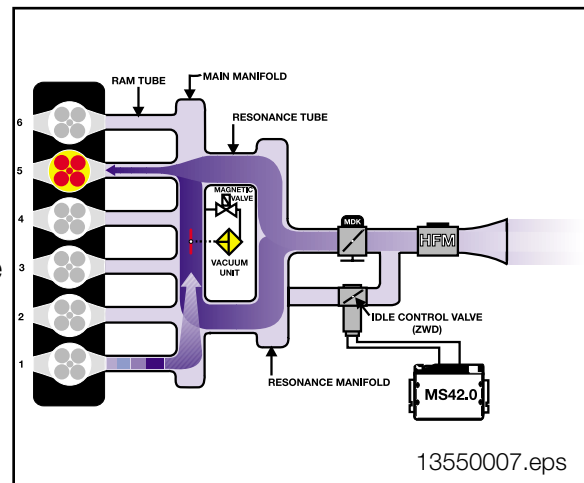

Suction Jet Pump: The ECM regulates the Suction Jet Pump (1) to provide sufficient vacuum for the brake booster under all operating conditions. The ECM controls the Suction Jet Pump Solenoid (2) to allow vacuum flow through.

Additional vacuum compensation is applied to the brake booster when the circuit is “deactivated” (solenoid sprung open).

Vacuum enhancement is limited to the brake booster when the control circuit is “activated” (solenoid powered closed).

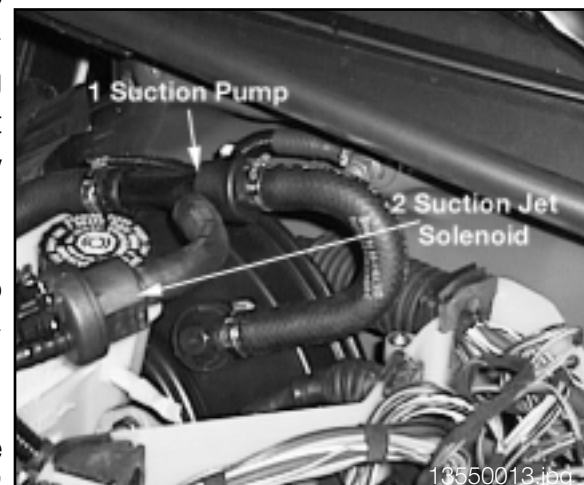

Pressure Control Valve: The pressure control valve varies the vacuum applied to the crankcase ventilation depending on engine load. The valve is balanced between spring pressure and the amount of manifold vacuum.

The oil vapors exit the separator labyrinth (2) in the cylinder head cover (1). The oil vapors are drawn into the cyclone type liquid/vapor separator (3) regulated by the pressure control valve (5). The oil vapors exit the pressure control valve into the intake manifold. The collected oil will drain back into the oil pan (4).

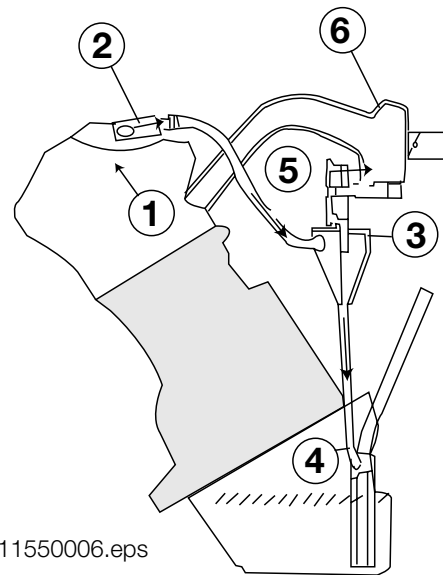

The vapors exit the pressure control valve and are drawn into the intake manifold through an external distribution tube (2). The tube has a splice at the front to equally distribute vapors to the back.

As the vapors exit the pressure control valve, they are drawn into the intake manifold through this external tube for even distribution.

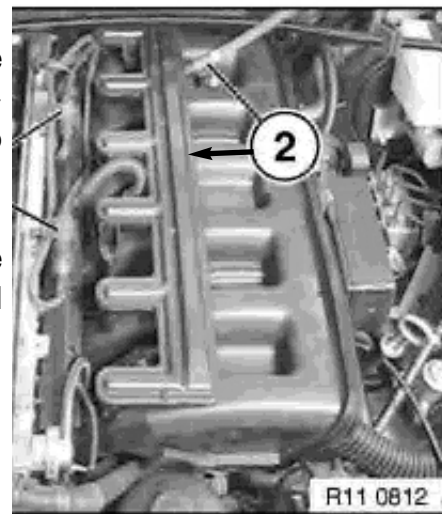

At idle when the intake manifold vacuum is high, the vacuum reduces the valve opening allowing a small amount of crankcase vapors to be drawn into the intake manifold. At part to full load conditions when intake manifold vacuum is lower, the spring opens the valve and additional crankcase vapors are drawn into the intake manifold.

1. Engine Oil Vapors
2. Collective Drain Back Oil
3. Oil Vapors to the Intake Manifold (Distribution Tube)

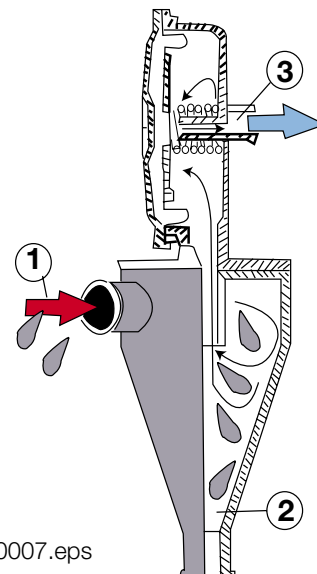

Principle of Operation

Air flow into the engine is regulated by the Throttle Valve and/or the Idle Air Actuator. Both of these air “passages” are necessary for smooth engine operation from idle to full load. On the MS42/MS43 system, the Throttle Valve and the Idle Air Actuator are **electrically controlled**. All of the ECM monitoring, processing and output functions are a result of regulated air flow.

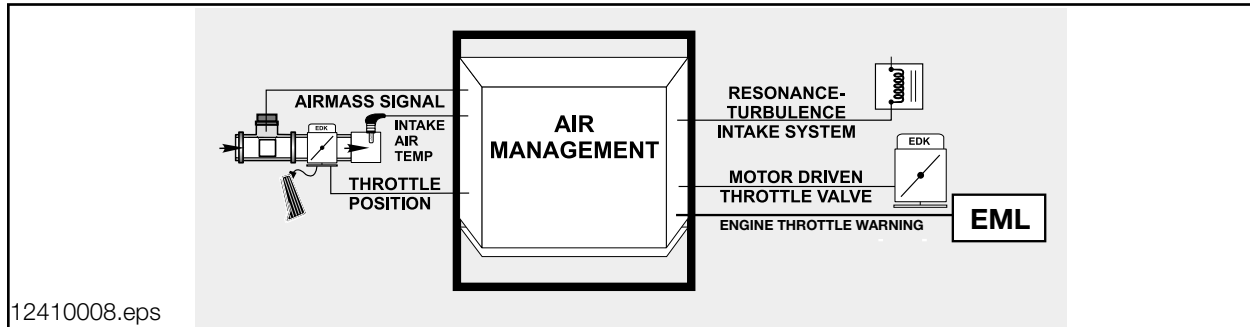

The Accelerator Pedal Position (PWG) is monitored by the ECM for pedal angle position and rate of movement. As the accelerator is moved, a rising voltage signal from the potentiometers/Hall sensors requests acceleration and at what rate. The ECM will increase the volume of fuel injected into the engine, advance the ignition timing and open the Throttle Valve and/or Idle Air Actuator.

The “full throttle” position indicates maximum acceleration to the ECM, and in addition to the functions just mentioned, this will have an effect on the air conditioning compressor (covered in Performance Controls).

As the accelerator pedal is released (integral springs), a decrease in voltage signals the ECM to activate fuel shut off if the RPM is above idle speed (coasting). The Throttle Valve will be closed and Idle Air Actuator Valve will open to maintain idle speed.

The ECM monitors the engine idle speed in addition to the accelerator pedal position and throttle position voltage. If the voltage values have changed (mechanical wear of throttle plate or linkage), the ECM will adjust the Idle Air Actuator to maintain the correct idle speed.

The potentiometers/Hall sensors are non-adjustable because the ECM “learns” the throttle angle voltage at idle speed. If the throttle housing/accelerator pedal module is replaced, the **ADAPTATIONS MUST BE CLEARED and ADAPTATION PROCEDURE MUST BE PERFORMED** using the DISplus/MoDIC. **If this is not performed, the vehicle will not start, or run in “fail-safe” mode.**

If this input is defective, a fault code will be stored and the “Malfunction Indicator and/or EML” Light will be illuminated. Limited engine operation will be possible.

The MS42 PWG (Driver's Wish)

pedal position sensor is integrated in the MDK assembly. The PWG section of the MDK consists of two separate potentiometers with independent voltage supply and monitor circuits (provided by the ECM).

The pedal position sensor is monitored by checking each individual sensor circuit and comparing the two values. Monitoring is active as soon as the sensors receive voltage (KL15).

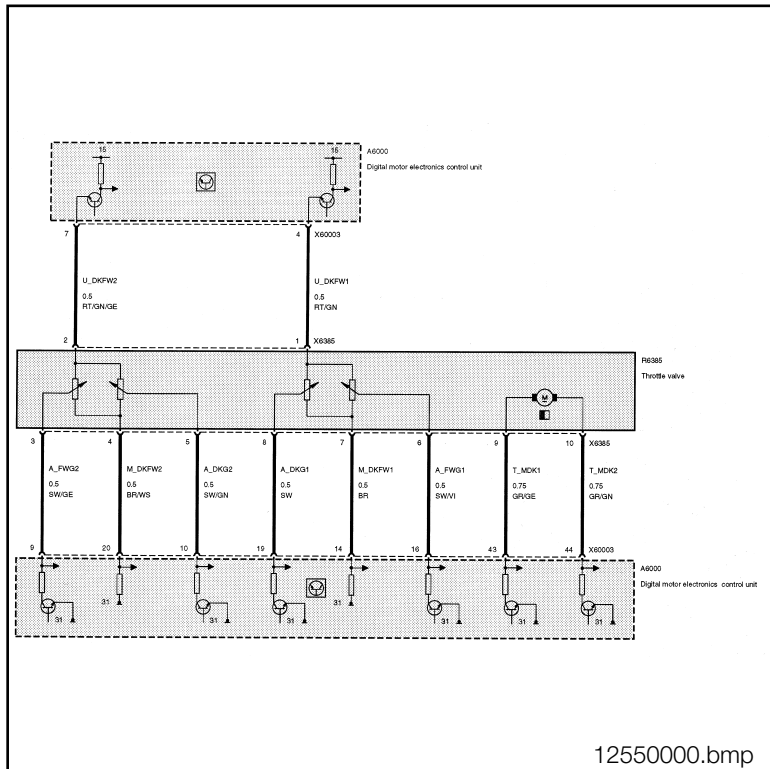

The MS43 PWG

pedal position sensor consists of two separate Hall sensors with different voltage characteristics and independent power supply (located in the accelerator pedal module).

The pedal position sensor is monitored by checking each individual sensor circuit and comparing the two pedal values. Monitoring is active as soon as the sensors receive voltage (KL15). The ECM decides what operating mode the pedal position sensor is to assume.

- **Mode 0 = Pedal position sensor fully operable**
- **Mode 1 = Failure of one pedal position sensor (maximum engine speed is limited)**
- **Mode 2 = Failure of both pedal position sensors (engine speed limited to 1500 rpm)**

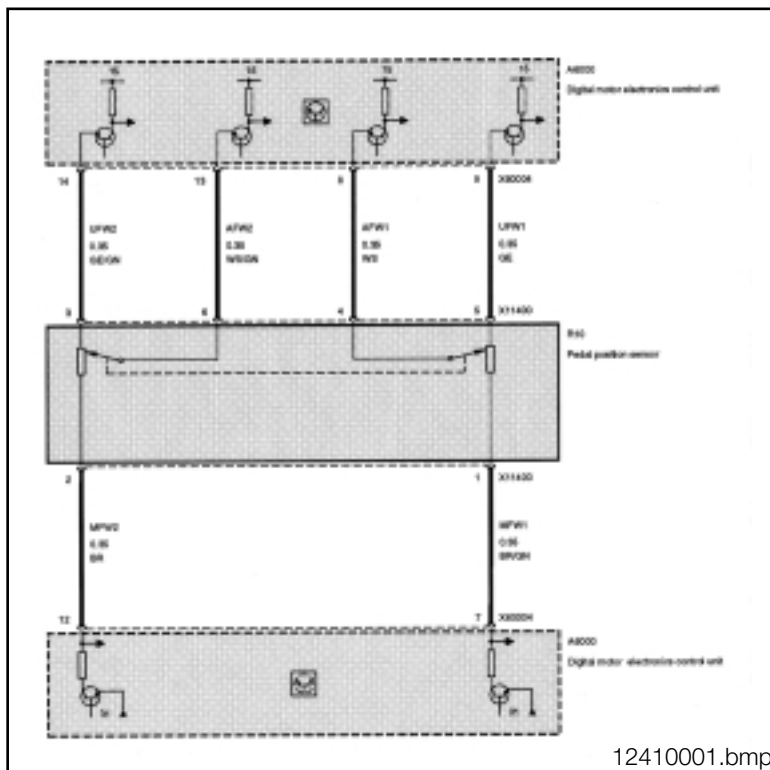

The Idle Air Actuator is controlled by the ECM modulating the ground signals (PWM at 100 Hz) to the valve. By varying the duty cycle applied to the windings, the valve can be progressively opened, or held steady to maintain the idle speed.

The ECM controls the Idle Air Actuator to supply the necessary air to maintain idle speed. When acceleration is requested and the engine load is low (<15%), the actuator will also supply the required air.

The basic functions of the idle speed control are:

- **Control the initial air quantity (air temp <0° C, MDK/EDK is simultaneously opened).**
- **Variable preset idle based on load and inputs.**
- **Monitor RPM Feedback for each preset position.**
- **Lower RPM range intake air flow (even while driving)**
- **Vaccum Limitation**
- **Smooth out the transition from acceleration to deceleration.**

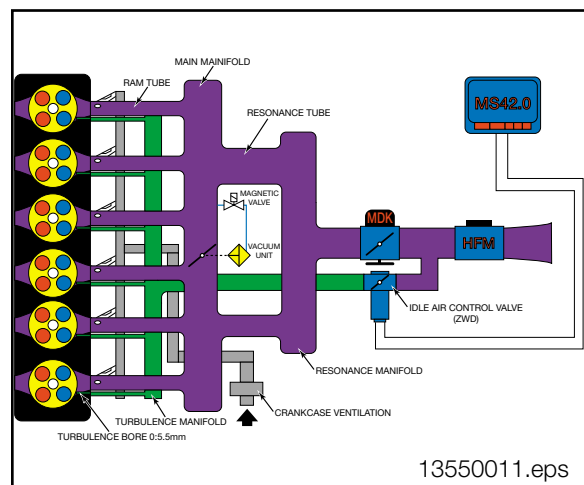

Under certain engine operating parameters, the MDK/EDK throttle control and the Idle Air Actuator are operated simultaneously. This includes all idling conditions and the transition from off idle. As the request for load increases, the idle valve will remain open and the MDK/EDK will supply any additional air volume required to meet the demand.

Emergency Operation of Idle Air Actuator:

If a fault is detected with the Idle Air Actuator, the ECM will initiate failsafe measures depending on the effect of the fault (increased air flow or decreased air flow). If there is a fault in the Idle Air Actuator/circuit, the MDK/EDK will compensate to maintain idle speed. The “Malfunction Indicator and/or EML” Light will be illuminated to inform the driver of a fault.

If the fault causes increased air flow (actuator failed open), VANOS and Knock Control are deactivated which noticeably reduces engine performance.

The MS42 MDK Feedback Signal Monitoring/Emergency Operation when a fault is detected in the system is as follows:

- | |
|--|
| <ul style="list-style-type: none">• Emergency operation 1 - Faults which do not impair actuator control, but which adversely affect the functioning of the MDK. |
| <ul style="list-style-type: none">• Emergency operation 2 - Applies when faults are encountered which might affect the performance of the MDK. |
| <ul style="list-style-type: none">• Emergency operation of idle Air Actuator. |

EMERGENCY OPERATION 1

Emergency operation 1 limits the dynamic operation if one or more of the potentiometers fail. The engine can slowly reach maximum speed with limited power.

EMERGENCY OPERATION 2

If another fault is encountered in addition to emergency operation 1 or if the plausibility is affected, emergency operation 2 is activated by the ECM. An example of plausibility fault would be that the pulley position does not match the MDK position and the associated airflow (from the HFM). Emergency operation 2 can also be initiated by simultaneously pressing both the accelerator pedal and the brake pedal, or if a fault is encountered in the brake light switch diagnosis (see Performance Controls).

When in emergency 2 operation mode, there is an engine speed limitation (slightly above idle speed) in addition to the measures for emergency operation 1. In emergency operation 2, the engine speed is always limited to 1300 RPM if the brake is not applied, and approximately 1000 RPM if the brake is applied. The vehicle speed is limited to approximately 20-25 mph.

The emergency operation functions are inactive when:

- | |
|---|
| <ul style="list-style-type: none">• Emergency operation 1 - Faults which affect the functioning of the MDK. |
| <ul style="list-style-type: none">• Emergency operation 2 - Applies when faults are encountered which might affect driveability. |
| <ul style="list-style-type: none">• Emergency operation of Idle Air Actuator. |

Further Monitoring Concepts

The MDK safety concept can detect a jammed or binding throttle valve as well as a broken link spring. This fault is detected by the ECM monitoring the feedback potentiometers from the MDK in relation to the pulse width modulation to activate the MDK motor.

Emergency operation functions if the throttle valve is jammed:

- | |
|---|
| <ul style="list-style-type: none">• Activation of the “EML” Light to alert the driver of a fault. |
| <ul style="list-style-type: none">• MDK is deactivated, the throttle valve is compensated for by closing the idle speed actuator and retarding the ignition (engine power reduction). |
| <ul style="list-style-type: none">• To maintain vehicle control, the MDK opening is compensated for by closing the idle speed actuator and retarding the ignition (engine power actuator). |
| <ul style="list-style-type: none">• Engine power is further limited by fuel injector cutout. |

In the event of a fault, the DISplus or MoDIC must be used to interrogate the fault memory, and clear the fault once the proper repair has been performed.

The MS43 EDK Feedback Signal Monitoring/Failsafe Operation when a fault is detected in the system is as follows:

• **The EDK provides two separate signals from two integrated potentiometers (Pot 1 and Pot 2) representing the exact position of the throttle plate.**

• **EDK Pot 1 provides the primary throttle plate position feedback. As a redundant monitoring feature, Pot 2 is continuously cross checked with Pot 1 for signal plausibility.**

• **If plausibility errors are detected between Pot 1 and Pot 2, MS 43.0 will calculate the inducted engine air mass (from HFM signal) and only utilize the potentiometer signal that closely matches the detected intake air mass.**

- **The MS 43.0 uses the air mass signalling as a “virtual potentiometer” (pot 3) for a comparative source to provide failsafe operation.**

- **If MS 43.0 cannot calculate a plausible conclusion from the monitored pots (1 or 2 and virtual 3) the EDK motor is switched off and fuel injection cut out is activated (failsafe operation is not possible).**

• **The EDK is continuously monitored during all phases of engine operation. It is also briefly activated/adapted when KL 15 is initially switched on as a “pre-flight check” to verify its mechanical integrity (no binding, appropriate return spring tension, etc). This is accomplished by monitoring both the motor control amperage and the reaction speed of the EDK feedback potentiometers. If faults are detected the EDK motor is switched off and fuel injection cut off is activated (failsafe operation is not possible). The engine does however continue to run extremely rough at idle speed.**

• **When in emergency operation, the engine speed is always limited to 1300 RPM by fuel injector cutout, and activation of the “EML” Light to alert the driver of a fault.**

• **When a replacement EDK is installed, the MS 43.0 adapts to the new component (required amperage draw for motor control, feedback pot tolerance difference, etc). This occurs immediately after the next cycle of KL15 for approximately 30 seconds. During this period of adaptation, the maximum opening of the throttle plate is 25%.**

The Total Intake Air Flow Control is performed by the ECM simultaneously operating the MDK/EDK throttle control and the Idle Air Actuator.

The ECM detects the driver's request from the potentiometers/Hall Sensors monitoring the accelerator pedal position. This value is added to the Idle Air control value and the total is what the ECM uses for MDK/EDK activation. The ECM then controls the Idle Air Actuator to satisfy the idle air "fill". In addition, the MDK/EDK will also be activated = pre-control idle air charge. Both of these functions are utilized to maintain idle RPM.

The MDK/EDK is electrically held at the idle speed position, and all of the intake air is drawn through the Idle Air Actuator. Without a load on the engine (<15%), the MDK/EDK will not open until the extreme upper RPM range. If the engine is under load (>15%), the Idle Air Actuator is open and the MDK/EDK will also open.

MDK: In the upper PWG range (approximately >60%), the MDK is switched off. The throttle valve is opened wider exclusively by the pulley via the spring linkage.

At the full throttle position, "kickdown" is obtained by depressing the accelerator pedal fully. This will overwind the pulley, but the spring linkage will not move the throttle plate past 90 degrees of rotation.

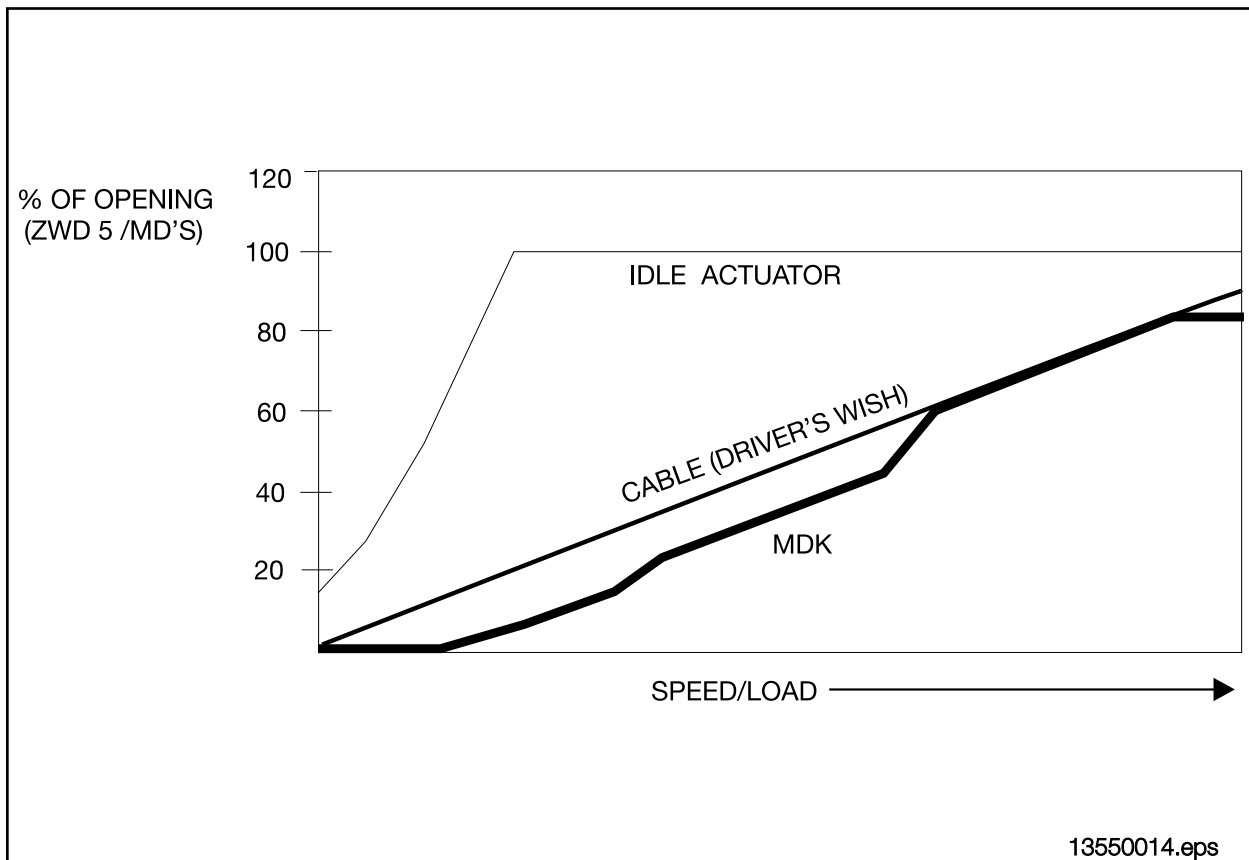

The Hot-Film Air Mass Meter (HFM) varies voltage monitored by the ECM representing the measured amount of intake air volume. This input is used by the ECM to determine the amount of fuel to be injected.

The heated surface of the hot-film in the intake air stream is regulated by the ECM to a constant temperature of 300° C above intake air temperature. The incoming air cools the film and the ECM monitors the changing resistance which affects current flow through the circuit. The hot-film does not require a “clean burn”, it is self cleaning due to the high operating temperature for normal operation.

If this input is defective, a fault code will be set and the “Malfunction Indicator Light” will illuminate when the OBD II criteria is achieved. The ECM will maintain engine operation based on the Throttle Position Sensors and Crankshaft Position/Engine Speed Sensor.

The Air Temperature signal allows the ECM to make a calculation of intake air temperature. The varying voltage input from the NTC sensor indicates the larger proportion of oxygen found in cold air, as compared to less oxygen found in warmer air. The ECM will adjust the amount of injected fuel because the quality of combustion depends on oxygen sensing ratio.

The ignition timing is also affected by air temperature. If the intake air is hot the ECM retards the base ignition timing to reduce the risk of detonation. If the intake air is cooler, the base ignition timing will be advanced. The ECM uses this input as a determining factor for Secondary Air Injection activation (covered in the Emissions section).

If this input is defective, a fault code will be set and the “Malfunction Indicator Light” will illuminate when the OBD II criteria is achieved. The ECM will maintain engine operation based on the HFM and Engine Coolant Temperature sensor.

The Suction Jet Pump is regulated by the ECM to provide sufficient vacuum for the brake booster under all operating conditions. The ECM controls the Suction Jet Pump Solenoid to allow vacuum flow through. The additional vacuum compensation is activated by the ECM when the idle air actuator is regulated for:

- | |
|--|
| • A/C Compressor “on” |
| • Vehicle in gear and the clutch is released (driving under load) |
| • Engine in warm-up phase <70° C |

Additional vacuum compensation is applied to the brake booster when the circuit is “deactivated” (Solenoid sprung open). Vacuum enhancement is limited to the brake booster when the control circuit is “activated” (Solenoid powered closed).

Workshop Hints

Air Management

Unmetered air leaks can be misleading when diagnosing faults causing “Malfunction Indicator Light”/driveability complaints. Refer to S.I. # 11 03 92 (3500) for testing intake vacuum leaks.

Crankcase Ventilation System

A fault in this system can often “mislead” diagnosis. This type of fault can produce:

- Mixture/misfire detected codes
- Whistling noises
- Performance/driveability complaints

Please refer to the following Service Information Bulletins for details on the **Crankcase Ventilation System**:

- Crankcase Ventilation System Check S.I. #11 05 98

Throttle Position Sensors - Testing

The Throttle Position Sensors can be tested with the following methods:

- DISplus Status Page (approx. 0.5v. to 4.5v)
- DISplus Oscilloscope - Select from the Preset Measurement which requires taking the measurement with the ECM and Universal Adapter connected to the circuit (as shown on the right).
- MS42: Resistance check of the dual potentiometer circuits, using the Universal Adapter with the ECM disconnected.
- MS43 (shown): Voltage check of the dual Hall sensor circuits, using the Universal Adapter with the ECM disconnected.

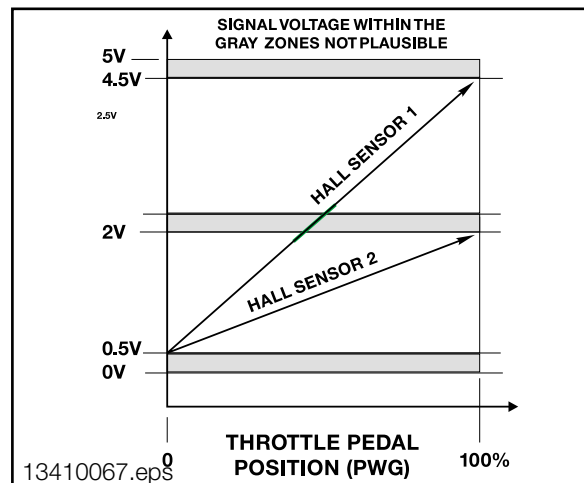

Idle Air Actuator Valve - Testing

- The Idle Air Actuator Valve and air circuit (passage ways) should be checked for physical obstructions. Visually inspect the sealing gasket (1), mounting (2) and air hose clamps (3).
- The resistance of the valve winding should be checked.
- The ECM output and Idle Speed Control Valve operation can be tested by "Component Activation" on the DISplus/MoDIC.
- The Pulse Width Modulated ground outputs from the ECM can be tested using the DISplus/MoDIC Oscilloscope.
- Consult Technical Data for specified idle speed.

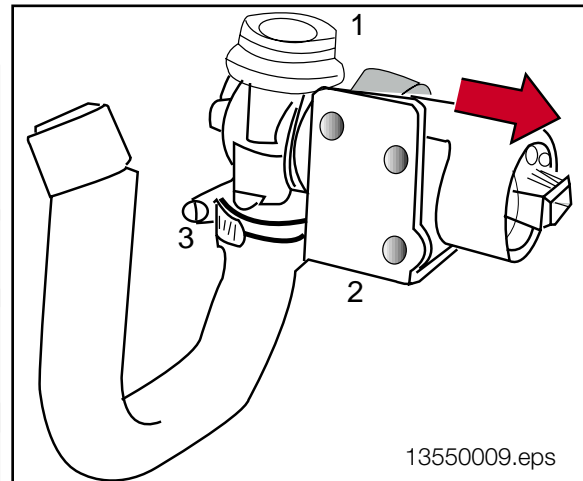

NOTE: If the valve is blocked or contaminated, an HFM fault code can also be present.

For complaints on M54 3.0 Hesitates, Stumbles at Idle refer to Service Information Bulletins:

- S.I. #12 51 00 and #12 10 00 on ECM Calibration

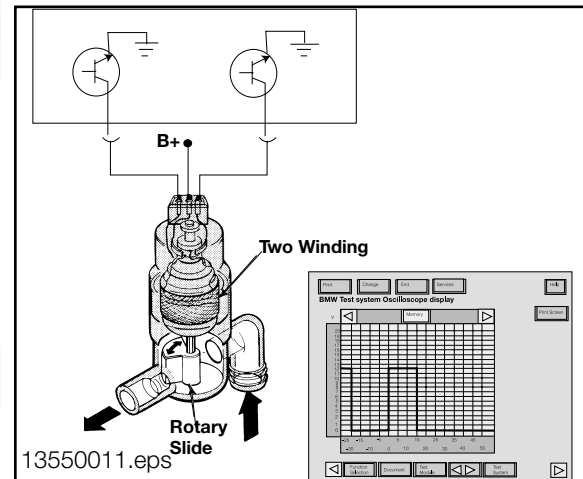

Air Temperature Signal - Testing

NTC sensors decrease in resistance as the temperature rises and vice versa. The ECM monitors the sensor voltage which varies as temperature changes the resistance value. For example, as temperature rises:

- Resistance through the sensor decreases.
- Voltage drop across the sensor decreases.
- Input signal voltage also decreases (5 - 0v)

This sensor should be tested using:

- DISplus/Modic Status page
- DISplus/Modic Multimeter
2.2 - 2.7 k ohms at 20° C

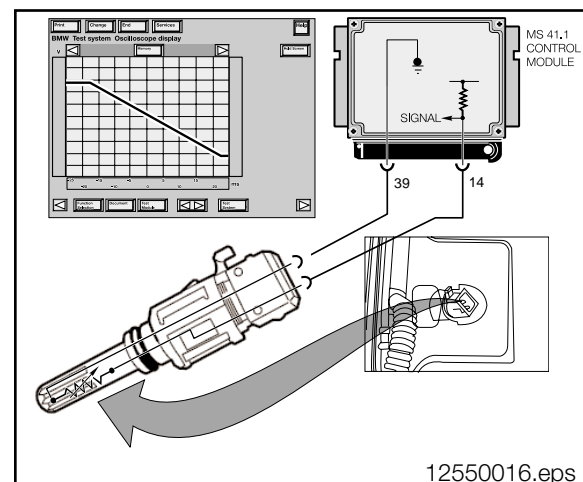

Hot-Film Air Mass Sensor

This component is non-adjustable and tampering is not permitted. A faulty Hot-Film Air Mass Sensor can produce the following complaints:

- **Difficult To Restart When Engine Is Hot**
- **Engine Starts Then Stalls**
- **“Malfunction Indicator Light” Illuminated**
- **Engine Starts And Runs Only With Accelerator Pedal Depressed**

Testing: The Hot-Film Air Mass Sensor can be tested with the following methods:

- **DISplus/MoDIC Fault Code and Component Testing.**
- **DISplus Status Page**
- **DISplus Oscilloscope - which requires taking the measurement with the ECM and the Universal Adapter connected to the circuit (engine running).**

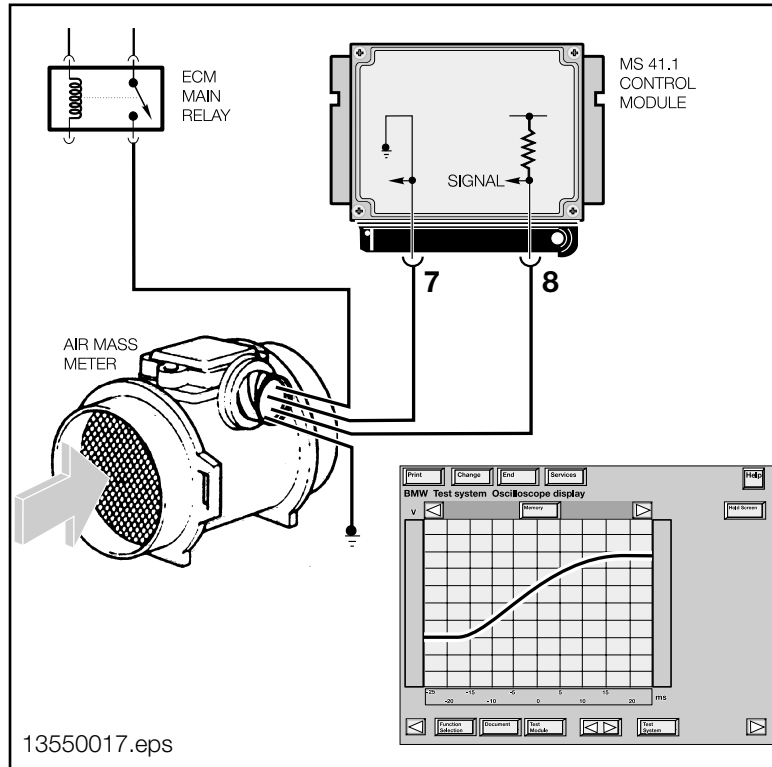

NOTE: Visually inspect the sensor for damaged, missing or blocked screens. The screens affect air flow calibration. Also inspect the sealing rings where the sensor inserts in the air filter housing and intake boot. Ensure the pin connections are tight.

MS42 MDK

- If a vehicle has a customer complaint of the “Malfunction Indicator and/or EML” Light on and fault codes relating to the **MDK/plausibility**, refer to the Service Information Bulletin “**Motor Driven Throttle Valve (MDK)**” SI # 12 07 99 for further detailed troubleshooting.
- If a vehicle has a customer complaint of “**Engine Speed Appears To Hang During Shifts**”, refer to the Service Information Bulletin SI # 12 17 99. This SI further details troubleshooting regarding the **Clutch Switch/Circuit and upgrade to a three wire switch including ECM reprogramming.**

Tools and Equipment

The DISplus/Modic as well as a reputable hand held multimeter can be used when testing inputs/components.

It is best to make the checks at the ECM connection, this method includes testing the wiring harness.

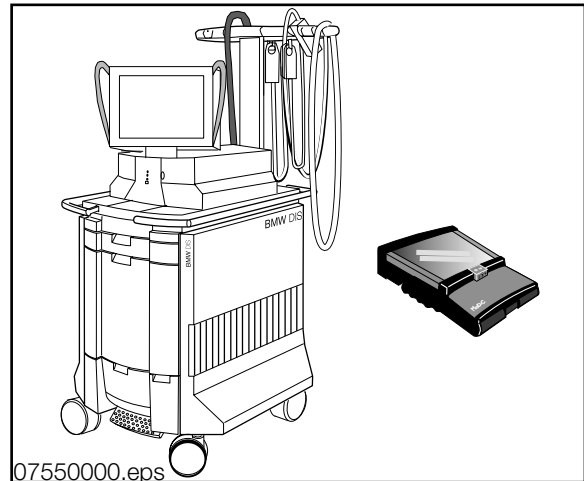

The correct Universal Adapter for the MS42/MS43 application should be used (#90 88 6 121 300). This will ensure the pin connectors and the harness will not be damaged.

When installing the Universal Adapter to the ECM (located in the Electronics Box in the engine compartment), make sure the ignition is switched off.

NOTE for MS43: Allow at least 3 minutes to elapse after the key was set to the "OFF" position before disconnecting the ECM/TCM. This will allow sufficient time to complete the DM TL test. Voltage may be present (up to 3 minutes) causing damage to the ECM/TCM if they are disconnected during this time period (arcing).

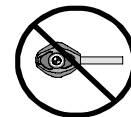
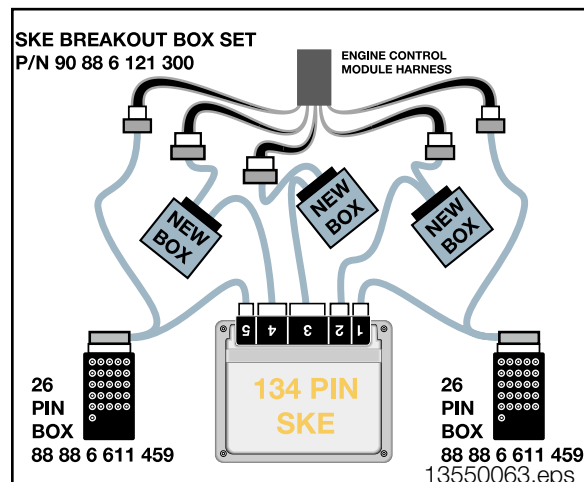

The Slack Tube Manometer Test Tool (#99 00 0 001 410) should be used to troubleshoot crankcase ventilation valves.

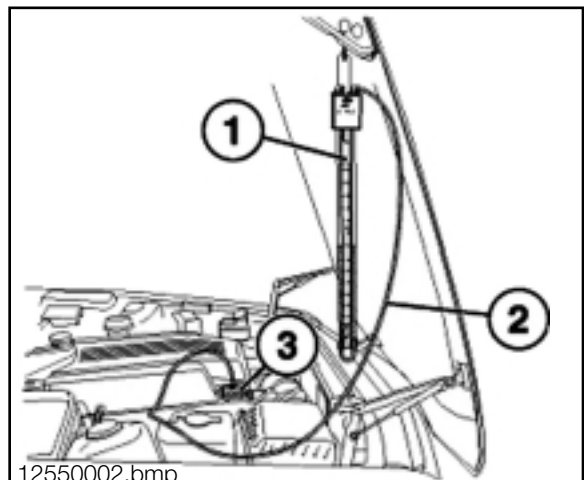

Fuel Management

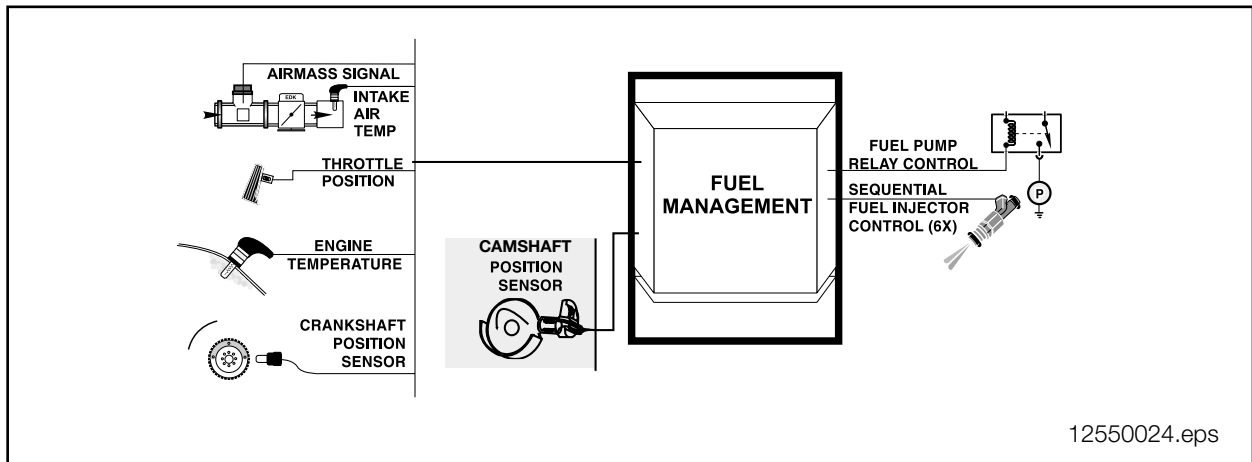

Fuel Tank: The fuel tank is made of high density polyethylene (reduced weight) which is manufactured to meet safety requirements.

A mid-chassis mounted “saddle” type tank is used (E46, E39, E53) which provides a tunnel for the driveshaft but creates two separate low spots in the tank.

A Syphon jet is required with this type of tank to transfer fuel from the left side, linked to the fuel return line.

As fuel moves through the return, the syphon jet creates a low pressure (suction) to pick up fuel from the left side of the tank and transfer it to the right side at the fuel pick up.

The Z3 uses a conventional type fuel tank that is mounted between the seats and the luggage compartment. The Z3 has a single sending unit that (with the fuel pump) is accessed from behind the passenger seat.

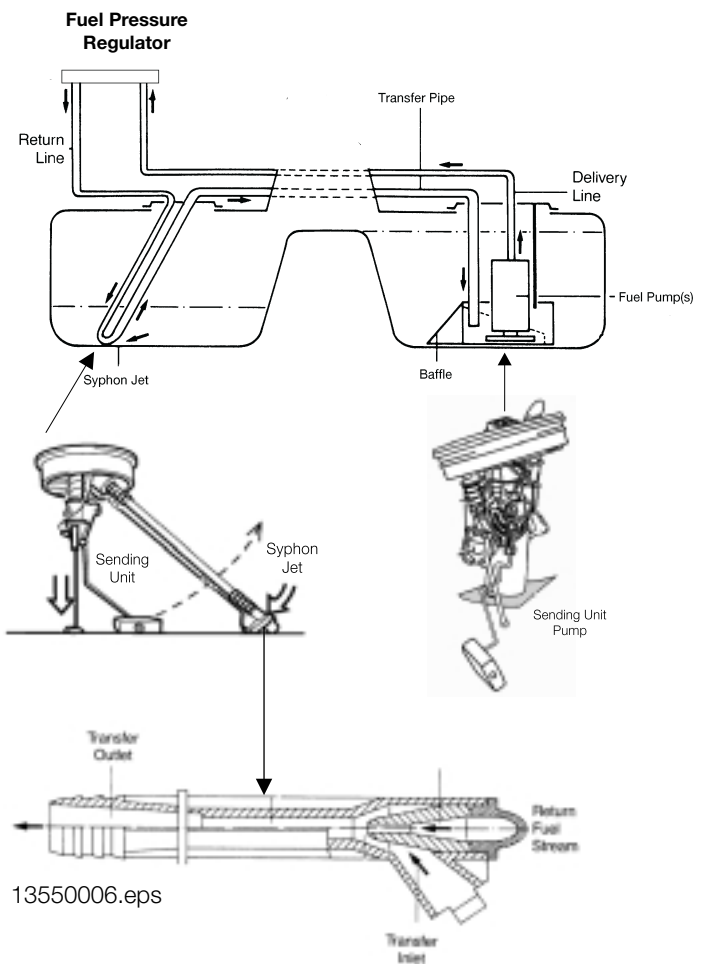

13550006.eps

Fuel Pump: The electric fuel pump supplies constant fuel volume to the injection system. This system uses a single submersible (in the fuel tank) pump. The inlet is protected by a mesh screen.

When the fuel pump is powered, the armature will rotate the impeller disc creating low pressure at the inlet. The fuel will be drawn into the inlet and passed through the fuel pump housing (around the armature). The fuel lubricates and cools the internals of the pump motor.

The fuel will exit through a non-return check valve to supply the injection system. The non-return check valve is opened by fuel exiting the pump and will close when the pump is deactivated. This maintains a “prime” of fuel in the filter, lines, hoses and fuel rail.

The pump contains an internal overpressure relief valve that will open (reducing roller cell pressure) if there is a restriction in the fuel supply hardware.

Fuel Supply Components: The fuel is transferred from the fuel pump to the fuel filter. The fuel filter “traps” contaminants before they reach the fuel injectors and should be replaced at the specified interval. The arrow on the filter denotes the installation direction (under the driver side floor). The large filter size also serves as a volume reservoir for pressurized fuel (dampening fuel pump pulsations).

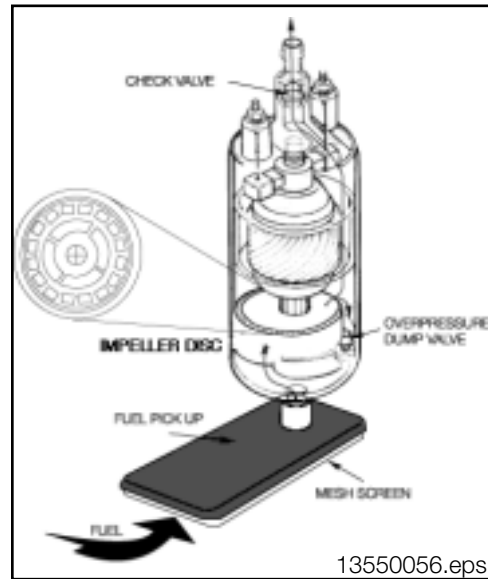

13550056.eps

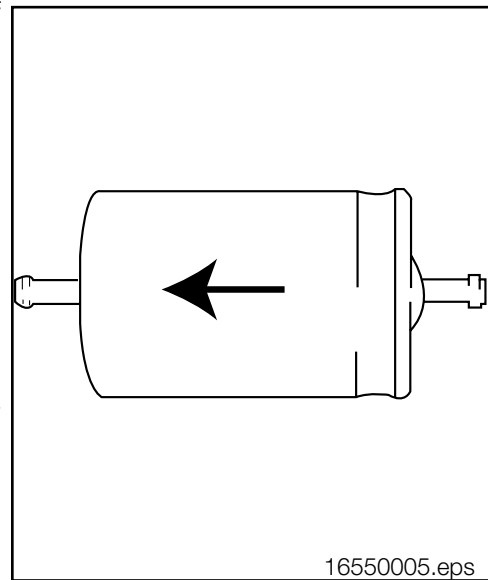

16550005.eps

MS42 Running Losses refers to the fuel vapors that can escape to the atmosphere during vehicle operation. The fuel pump delivers more volume than the injection system requires. The unused fuel is routed through a return line to the tank at the fuel pressure regulator integrated in the Running Losses 3/2 Way Valve under the driver side floor. The fuel is constantly circulated in this manner.

Using the by-pass type regulator reduces the returned fuel temperature to the tank.

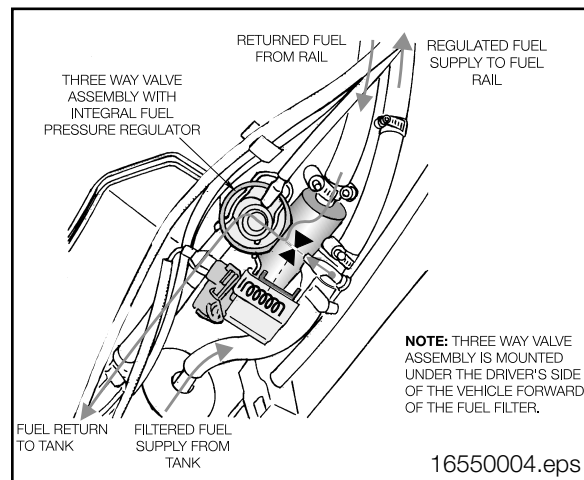

16550004.eps

MS42 Running Losses Fuel Supply: The ECM controls the operation of the Running Losses Fuel Circuit by activating the by-pass solenoid. The solenoid is energized for 20 seconds on engine start up to supply full fuel volume to the fuel rail. After 20 seconds, the solenoid is deactivated and sprung closed (the by-pass is opened). This reduces the amount of fuel circulating through the fuel rail and diverts the excess to return through the fuel pressure regulator.

The fuel injectors are provided with regulated fuel for injection but the returned fuel by-passes the engine compartment fuel rail thus lowering the temperature and amount of vaporization that takes place in the fuel tank.

The solenoid is also activated momentarily if an engine misfire is detected. This function provides full fuel flow through the fuel rail to determine if the misfire was caused by a lean fuel condition. The solenoid is monitored by the ECM for faults.

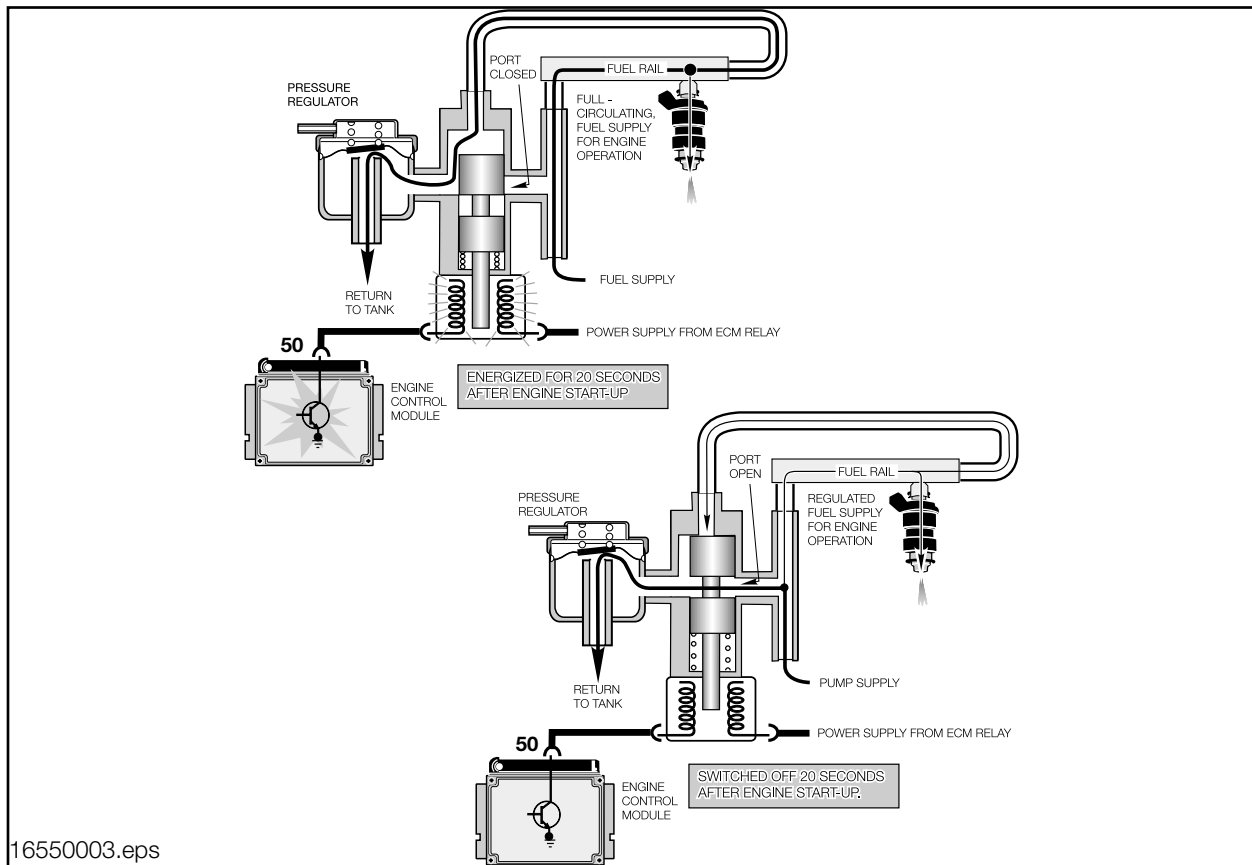

MS43 Fuel Supply: The fuel is supplied through a Non Return Fuel Rail System. This system meets Running Loss compliance without the use of the 3/2 Way Valve.

The fuel supply pressure is controlled by the 3.5 Bar fuel pressure regulator integrated in the fuel filter assembly. The regulator is influenced by internal fuel pressure and not intake manifold vacuum. The fuel exits the fuel pressure regulator supplying the fuel rail and the injectors. The fuel filter assembly is located under the left front floor area (next to the frame rail).

The fuel return line is located on the filter/regulator assembly which directs the unused fuel back to the fuel tank. The fuel tank hydrocarbons are reduced by returning the fuel from this point (lower temperatures) instead of from the fuel rail.

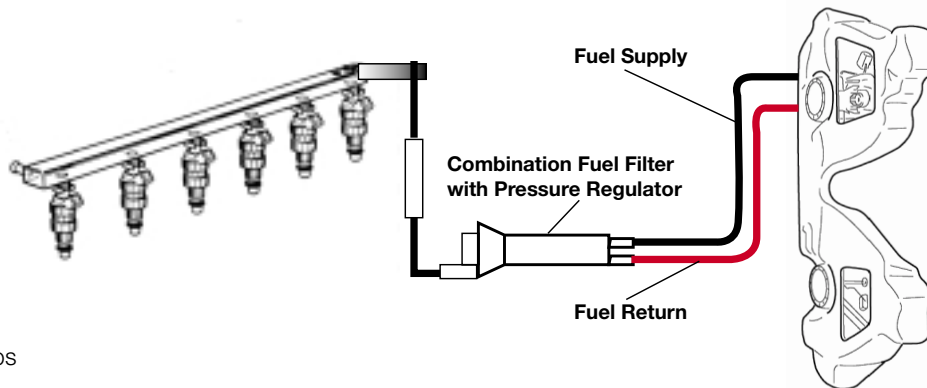

13550001.eps

The fuel rail distributes an even supply of fuel to all of the injectors, and also serves as a volume reservoir. The fuel rail is secured by bolts to the intake manifold.

Fuel Pressure Regulator: The Fuel Pressure Regulator maintains a constant pressure for the fuel injectors. The fuel pressure is set to 3.5 bar (+/- 0.2) by internal spring tension on the restriction valve. The attached fuel pressure regulator is not influenced by vacuum.

The ECM determines the fuel quantity compensation for manifold vacuum changes. This is based on throttle position, HFM and load for precise compensation.

A small hose is routed to the crankcase cyclone separator (in case of regulator diaphragm leakage). When the restriction valve opens, unused fuel returns from the regulator/filter assembly back to the fuel tank.

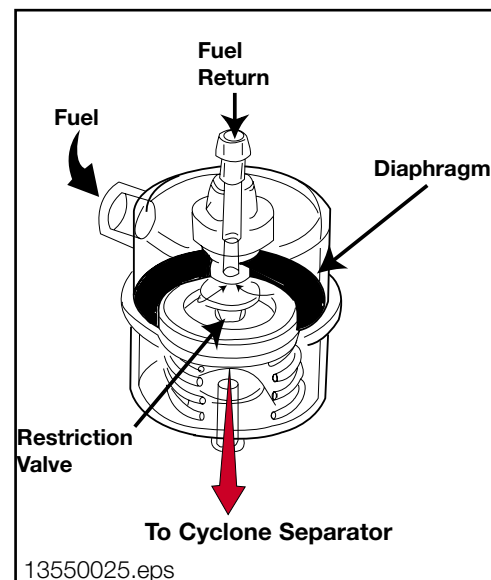

Siemens Fuel Injectors: The Fuel Injectors are electronically controlled solenoid valves that provide precise metered and atomized fuel into the engine intake ports. The Fuel Injector Valve consists of:

1.	Fuel Strainer
2.	Electrical Connector
3.	Solenoid Winding
4.	Closing Spring
5.	Solenoid Armature
6.	Needle Valve
7.	Pintle

Fuel is supplied from the fuel rail to the injector body. The fuel is channeled through the injector body to the needle valve and seat at the tip of the injector. Without electrical current, the needle valve is sprung closed against the seat.

The Fuel Injectors receive voltage from the ECM Relay. The ECM activates current flow through the injector solenoid creating a magnetic field that pulls the needle “up” off of its seat. The pressurized fuel flows through the tip of the injector that is fitted with a directional angle “plate” with dual outlets. This “fans out” the spray into an angled patterns which helps to atomize the fuel. When the ECM deactivates current flow, the needle valve is sprung closed against the seat and fuel flow through the injector is stopped. The lower portion of the injector body is jacketed in metal.

The length of time that the ECM activates the Fuel Injectors is very brief, the duration is in milli-seconds (ms). This affects the amount of fuel volume flowing through the Fuel Injectors. The ECM will vary the length of time (ms) to regulate the air/fuel ratio (mixture).

A Fuel Injector is faulty (mechanical or electrical), it can produce the following complaints:

• “Malfunction Indicator Light”	• Misfire/Rough Idle (Leaking or Blocked)
• Excessive Tailpipe Smoke (Leaking)	• Long Crank Time (Leaking)
• Engine Hydrolock (Leaking)	
• Oxygen Sensor/Mixture/Injector Related Fault Codes	

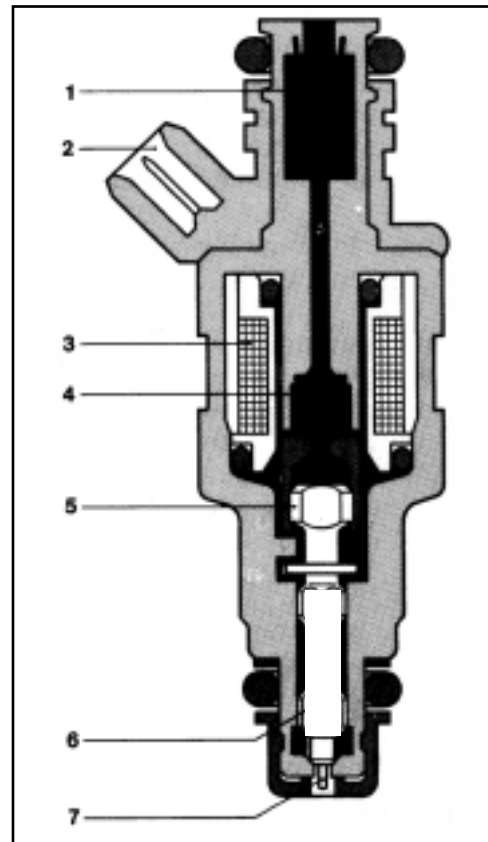

Crankshaft Position/RPM Sensor (Hall Effect): This sensor provides the crankshaft position and engine speed (RPM) signal to the ECM for fuel pump and Injector operation.

A Hall sensor is mounted on the left side at the rear of the engine block. The impulse wheel is mounted on the crankshaft inside the crankcase, at the rear main bearing support. The impulse wheel contains 58 teeth with a gap of two missing teeth.

The Hall sensor is supplied with voltage from the ECM. A digital square wave signal is produced by the sensor as the teeth of the impulse wheel pass by. The “gap” allows the ECM to establish crankshaft position.

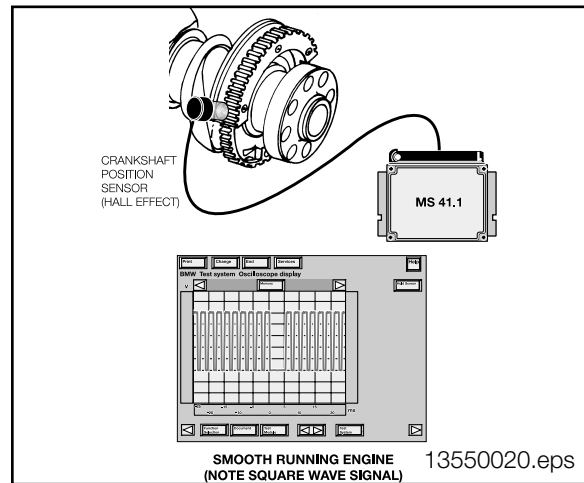

The crankshaft position sensor is monitored as part of OBD II requirements for Misfire Detection. If this input is faulty, the ECM will operate the engine (limited driveability) from the Camshaft Sensor input. A fault with this input will produce the following complaints:

- | | |
|--|---|
| • Hard Starting/Long Crank Time | • Driveability/Misfire/Engine Stalling |
| • “Malfunction Indicator Light” | |

Camshaft Sensors - Intake and Exhaust Camshafts

The "static" Hall sensors are used so that the camshaft positions are recognized once ignition is on (KL15) before the engine is started. The function of the intake cam sensor is:

- Cylinder “work cycle” for injection timing
- Synchronization
- Engine speed sensor (if crankshaft speed sensor fails)
- VANOS position control of the intake cam

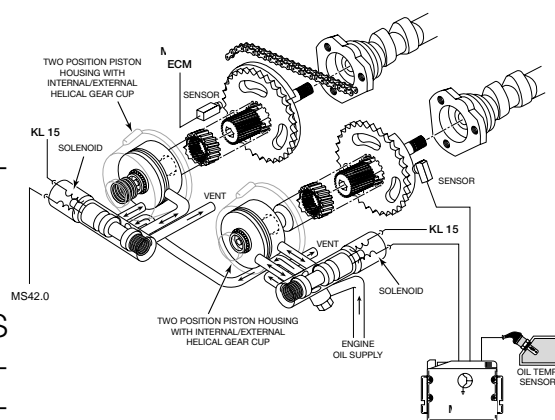

The exhaust cam sensor is used for VANOS position control of the exhaust cam. If these sensors fail there are no substitute values, the system will operate in the failsafe mode with no VANOS adjustment. The engine will still operate, but torque reduction will be noticeable.

NOTE: Use caution on repairs as not to bend the impulse wheels.

Engine Coolant Temperature: The Engine Coolant Temperature is provided to the ECM from an NTC type sensor located in the coolant jacket of the cylinder head (left rear). The sensor contains two NTC elements, the other sensor is used for the instrument cluster temperature gauge.

The ECM determines the correct air/fuel mixture required for the engine temperature by monitoring an applied voltage to the sensor (5v). This voltage will vary (0-5v) as coolant temperature changes the resistance value.

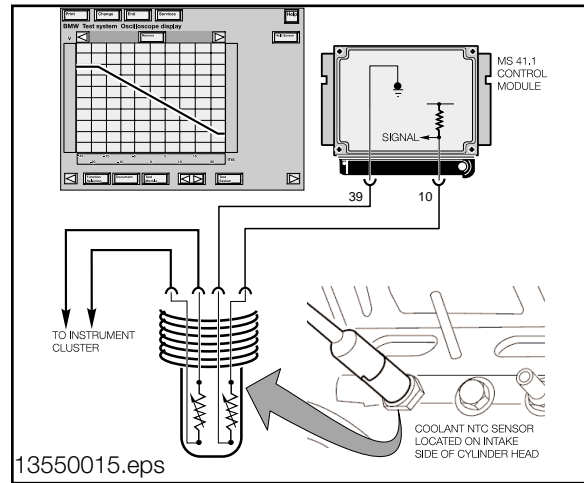

If the Coolant Temperature Sensor input is faulty, a fault code will be set the ECM will assume a substitute value (80° C) to maintain engine operation.

Throttle Position: For details about the sensor, refer to the Air Management section. As the throttle is opened, the ECM will increase the volume of fuel injected into the engine. As the throttle plate is closed, the ECM activates fuel shut off if the rpm is above idle speed (coasting).

Hot-Film Air Mass Meter (HFM): The air volume input signal is used by the ECM to determine the amount of fuel to be injected for correct air/fuel ratio. For details about the sensor, refer to the Air Management section.

Air Temperature: This signal allows the ECM to make a calculation of air density. For details about the sensor, refer to the Air Management section.

The varying voltage input from the NTC sensor indicates the larger proportion of oxygen found in cold air, as compared to less oxygen found in warmer air. The ECM will adjust the amount of injected fuel because the quality of combustion depends on oxygen sensing ratio.

Principle of Operation

Fuel Management delivers fuel from the tank to the intake ports of the engine. To accomplish this, **fuel supply** must be available to the fuel injectors. Then the fuel must be **injected** in the precise amount and at the correct time. The ECM does not directly monitor fuel supply, although it does control fuel supply. **The Fuel Pump** supplies fuel when it receives operating voltage from the Engine Control Module Relay supplying the Fuel Pump Relay. The ECM controls and monitors **fuel injection**.

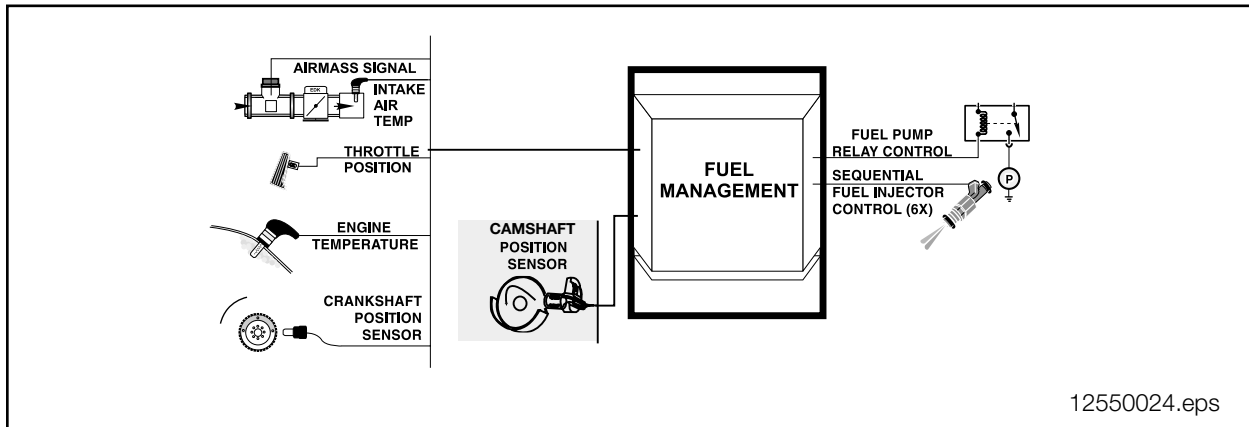

The Fuel Pump will be activated when the ignition (KL15) is switched “on” and the ECM supplies a ground circuit to activate the Fuel Pump Relay. The Fuel Pump Relay supplies operating power to the in-tank mounted fuel pump. This is a momentary activation to “pressurize” (prime) the fuel system.

The ECM then requires an engine speed signal from the Crankshaft Position/RPM Sensor to maintain continuous Fuel Pump Relay activation.

If the engine RPM signal is not present, the ECM will deactivate the Fuel Pump Relay.

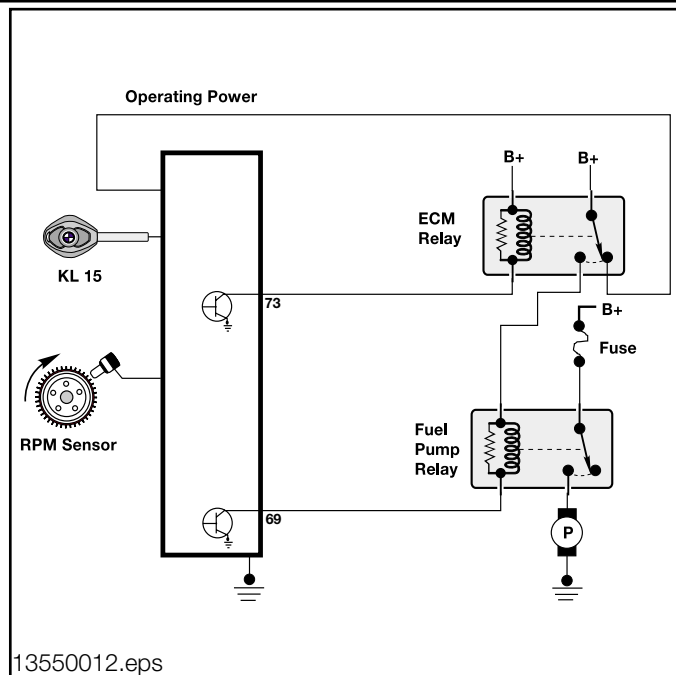

The Fuel Injectors will be opened by the ECM to inject pressurized fuel into the intake ports. The Fuel Injectors receive voltage from the Engine Control Module Relay. The ECM controls the opening by activating the ground circuits for the Solenoid Windings. The ECM will vary the duration (in milli-seconds) of “opening” time to regulate the air/fuel ratio.

The ECM has six Final Stage output transistors that switch ground to the six injector solenoids. The Injector “triggering” is first established from the Crankshaft Position/RPM Sensor.

The ECM is programmed to activate the Final Stage output transistors once for every two revolutions of the crankshaft in two groups (Semi-Sequential Injection).

The injectors are opened in two groups for every complete “working cycle” of the engine. This delivers the fuel charge for cylinders 1,5,3 during one revolution of the crankshaft and cylinders 6,2,4 during the second revolution of the crankshaft. This process enhances fuel atomization during start up.

During start up, the ECM recognizes the Camshaft Position (Cylinder ID) input. The camshaft position is referenced to the crankshaft position. It then switches the injection to Full Sequential. This process “times” the injection closer to the intake valve opening for increased efficiency.

When activated, each injector delivers the full fuel charge at separate times during each engine working cycle.

If this input is faulty, the ECM will activate the injectors in Parallel to maintain engine operation and set a fault code.

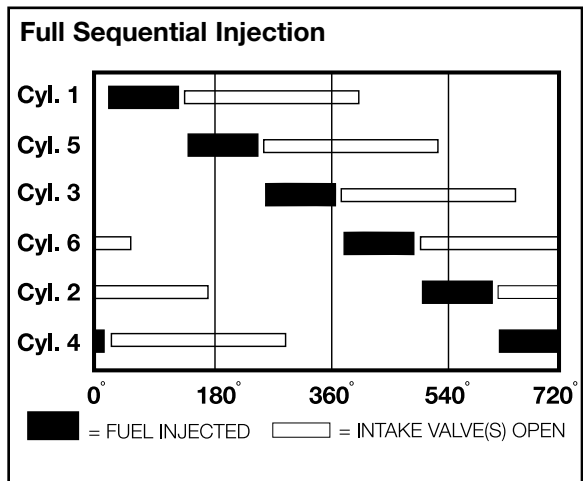
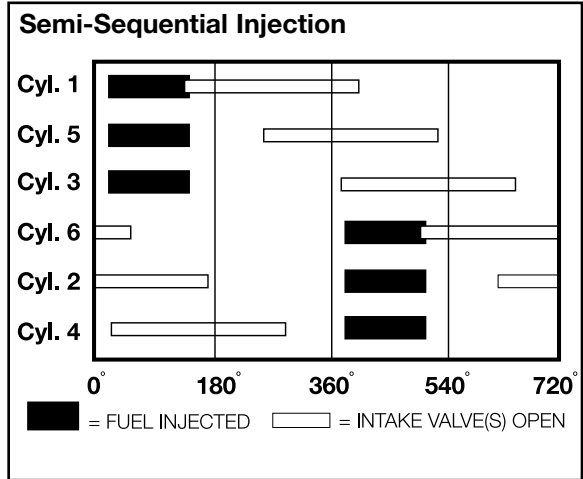
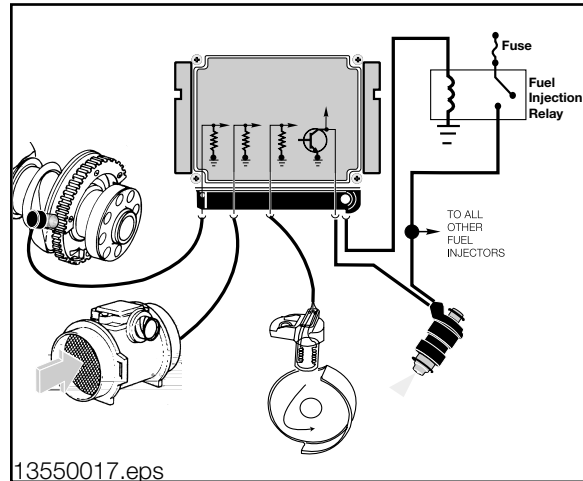

The Injector “open” Time to maintain engine operation after it has been started is determined by the ECM (programming). The ECM will calculate the injection “timing” based on a combination of the following inputs:

- **Battery Voltage**
- **Throttle Position**
- **Air Flow Volume/Mass**
- **Air Temperature**
- **Crankshaft Position/RPM**
- **Camshaft Position (Cylinder ID)**
- **Engine Coolant**
- **Oxygen Sensor (Detail in Emissions)**

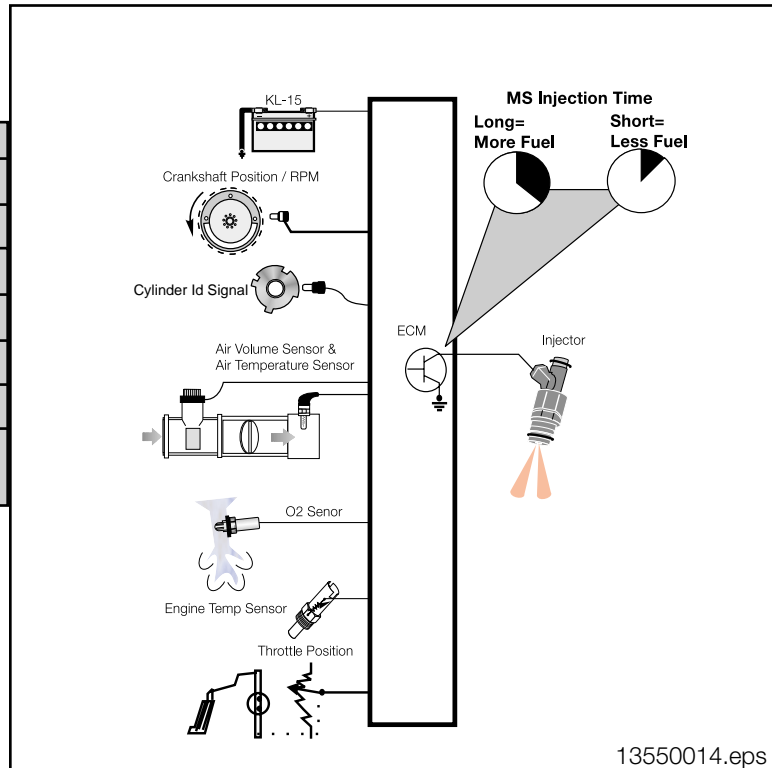

The injection ms value will be regulated based on battery voltage. When cranking, the voltage is low and the ECM will increase the ms value to compensate for injector “lag time”. When the engine is running and the battery voltage is higher, the ECM will decrease the injection ms value due to faster injector reaction time.

Cold starting requires additional fuel to compensate for poor mixture and the loss of fuel as it condenses onto cold intake ports, valves and cylinder walls. The cold start fuel quantity is determined by the ECM based on the Engine Coolant Temperature Sensor input during start up.

During cranking, additional fuel is injected (in Semi-Sequential) for the first few crankshaft revolutions. After the first few crankshaft revolutions, the injected quantity is metered down as the engine comes up to speed. When the engine speed approaches idle rpm, the ECM recognizes the Camshaft Position and switches to Full Sequential injection.

When the engine is cold, optimum fuel metering is not possible due to poor air/fuel mixing and an enriched mixture is required. The Coolant Temperature input allows the ECM to adjust the injection ms value to compensate during warm up and minimize the the injected fuel at engine operating temperature.

When the engine is at idle, minimum injection is required. Additional fuel will be added if the ECM observes low engine rpm and increasing throttle/air volume inputs (acceleration enrichment). As the throttle is opened, the ECM monitors acceleration and rate of movement. The ECM will increase the volume of fuel injected into the engine by increasing the injection ms value. The “full throttle” position indicates maximum acceleration and the ECM will add more fuel (full load enrichment).

As the throttle is closed, the ECM decreases the injection ms value (fuel shut off) if the rpm is above idle speed (coasting). This feature decreases fuel consumption and lowers emissions. When the engine rpm approaches idle speed, the injection ms value is increased (cut-in) to prevent the engine from stalling. The cut-in rpm is dependent upon the engine temperature and the rate of deceleration.

The Hot-Film Air Mass (HFM) signal provides the measured amount of intake air volume/mass. This input is used by the ECM to determine the amount of fuel to be injected to “balance” the air/fuel ratio.

The Air Temperature Signal allows the ECM to make an additional calculation of air density. The varying voltage input from the NTC sensor indicates the larger proportion of oxygen found in cold air, as compared to less oxygen found in warmer air. The ECM will adjust the amount of injected fuel because the quality of combustion depends on oxygen sensing ratio (details in Emissions).

The Crankshaft Position/RPM signals the ECM to start injection as well as providing information about the engine operation. This input is used in combination with other inputs to determine engine load which increases/decreases the injection ms value. Without this input, the ECM will not activate the injectors.

The Camshaft Position (Cylinder ID) affects the injection timing (Semi-Sequential/Full Sequential). To accomplish this, the ECM contains six Final Stage output transistors that activate the injectors individually. The engine operates sufficiently on Semi-Sequential Injection (two groups of three), but more efficiently on Full Sequential Injection (six individual). If one of the fuel injector circuits faulted, the engine can still operate on limited power from the other remaining fuel injector circuits.

Injection “Reduction” Time is required to control fuel economy, emissions, engine and vehicle speed limitation. The ECM will “trim” back or deactivate the fuel injection as necessary while maintaining optimum engine operation.

As the throttle is closed during deceleration, the ECM decreases the injection ms value (fuel shut off) if the rpm is above idle speed (coasting). This feature decreases fuel consumption and lowers emissions.

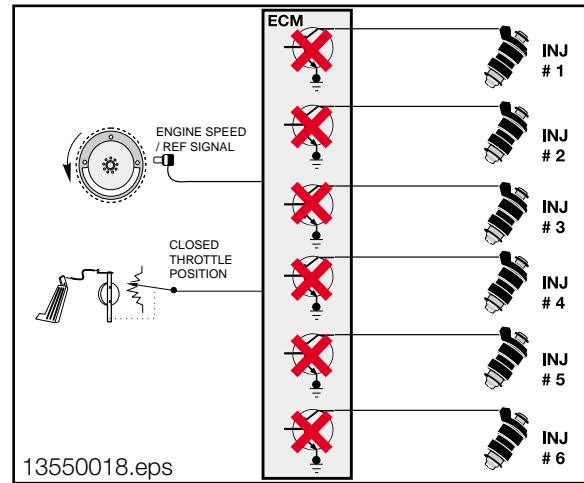

When the engine rpm approaches idle speed, the injection ms value is increased (cut-in) to prevent the engine from stalling. The cut-in rpm is dependent upon the engine temperature and the rate of deceleration. This function can be observed as displayed on the Fuel Economy (MPG) gauge.

The ECM will selectively deactivate injectors to control maximum engine rpm (regardless of vehicle speed). When the engine speed reaches 6500 rpm, the injectors will be individually deactivated as required to protect the engine from over-rev. As the engine speed drops below 6500 rpm, injector activation will be resumed. **This feature does not protect the engine from a forced over-rev such as improperly down-shifting a manual transmission equipped vehicle (driver error).**

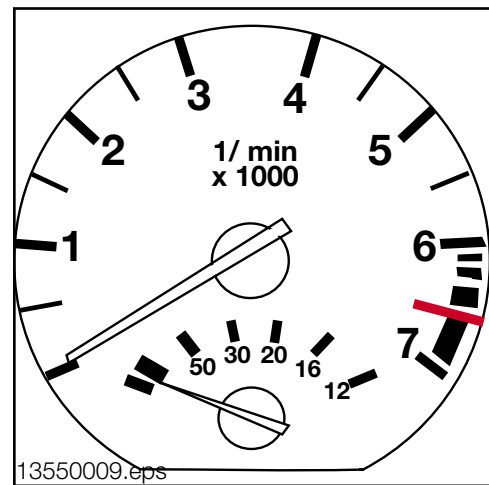

Maximum vehicle speed is also limited by the ECM selectively deactivating the injectors (regardless of engine rpm).

This limitation is based on the vehicle dimensions, specifications and installed tires (speed rating).

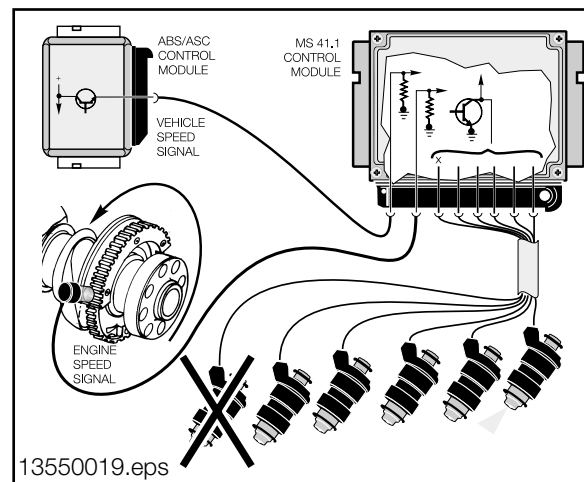

The ECM will also protect the Catalytic Converter by deactivating the injectors.

If the ECM detects a “misfire” (ignition, injection or combustion) it can selectively deactivate the Final Stage output transistor for that cylinder(s).

The injector(s) will not open, preventing unburned fuel from entering the exhaust system.

On the MS42/MS43 system, there are six individual injector circuits resulting in deactivation of one or multiples. This will limit engine power, but protect the Catalytic Converter.

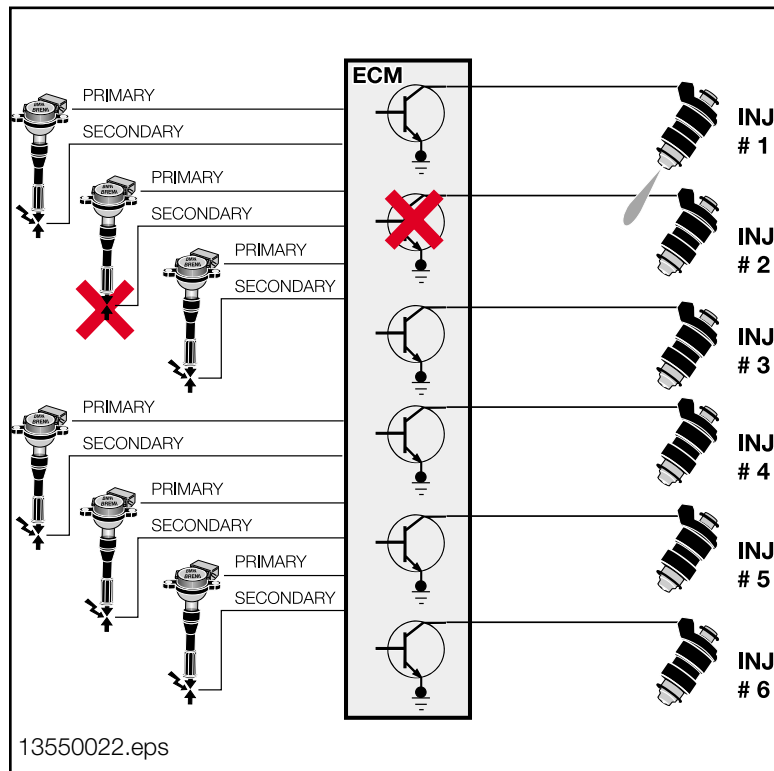

Fuel Injection Control Monitoring is performed by the ECM for OBD II requirements. Faults with the fuel injectors and/or control circuits will be stored in memory. This monitoring includes:

- Closed Loop Operation
- Oxygen Sensor Feedback

These additional corrections are factored into the calculated injection time. If the correction factor exceeds set limits a fault will be stored in memory.

When the criteria for OBD II monitoring is achieved, the “Malfunction Indicator Light” will be illuminated.

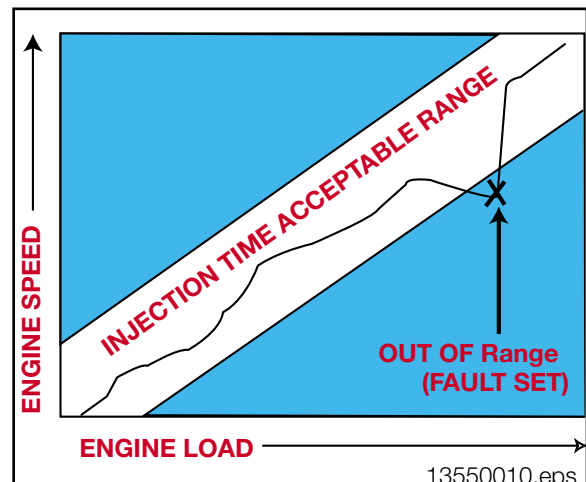

Workshop Hints

Before any service work is performed on any fuel system related component, always adhere to the following:

• Observe relevant safety legislation pertaining to your area.
• Ensure adequate ventilation.
• Use exhaust extraction system where applicable (alleviate fumes).
• DO NOT OPERATE THE FUEL PUMP unless it is properly installed in the fuel tank and is submersed in the fuel (fuel lubricates the pump).
• DO NOT SMOKE while performing fuel system repairs.
• Always wear adequate protection clothing including eye protection.
• Use caution when working around a HOT engine compartment.
• During fuel system repairs that involve “sealing rings”, always replace them with new COPPER sealing rings only.
• BMW does not recommend any UNAUTHORIZED MODIFICATIONS to the fuel system. The Fuel systems are designed to comply with strict federal safety and emissions regulations. In the concern of product liability, it is unauthorized to sell or perform modifications to customers vehicles, particularly in safety related areas.
• Always consult the Repair Instructions on the specific model you are working on before attempting a repair.

Fuel

Fuel quality should always be considered when diagnosing a driveability complaint. The type of fuel, proper AKI rating, impurities and moisture **are not factored by the ECM.**

Please refer to the Owner’s Manual and following Service Information Bulletins regarding fuel:

• Gasoline Fuel Quality S.I. #13 01 88 (1564)	• Gasoline Additive S.I. #13 04 88 (1591)
---	---

Fuel Supply

The fuel supply hardware should be visually inspected for damage that can affect pick-up, transfer, pressure and return. Please refer to the Repair Instructions and the following Service Information Bulletins details on fuel supply hardware:

• Fuel System Modifications S.I. #16 01 81

Fuel Pump and Sending Unit Access

All BMW vehicles have access plates to service the fuel pump and sending unit(s) without removing the fuel tank.

The E46/E39 access plates are located under the rear seat. The “saddle” type fuel tank (under rear seat) has two access plates.

The passenger side allows access to the fuel pump/sending unit. The driver side allows access to the sending unit.

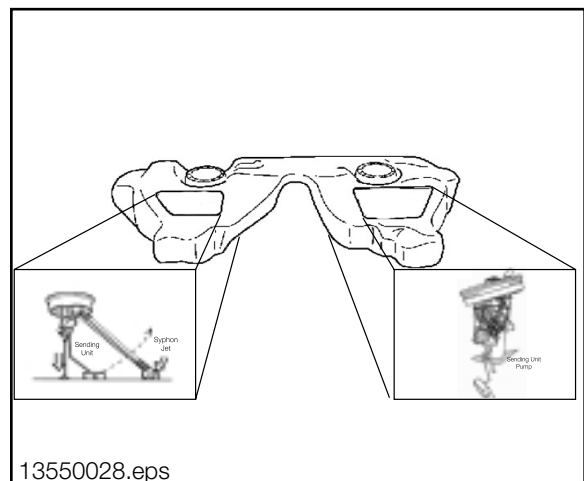
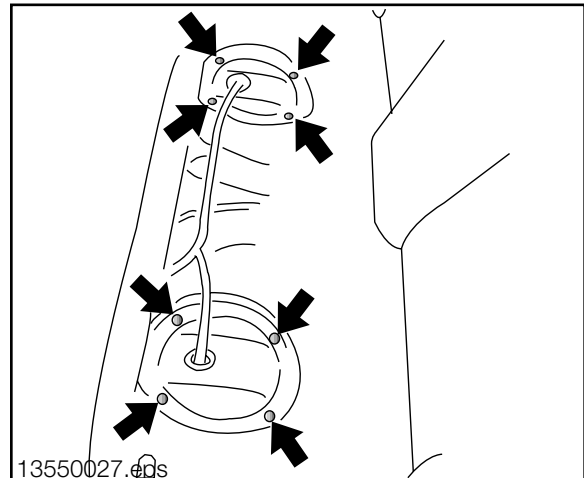

The Z3 has a single access plate located behind the passenger seat.

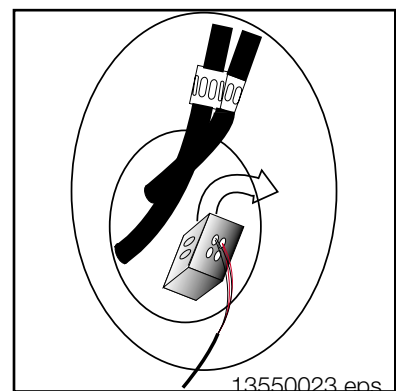

Draining the Fuel Tank

In order to remove the fuel tank it must be drained first to avoid fuel spills and handling excessive weight. In some cases depending on the fuel tank dimensions (vehicle specific), it is also necessary to drain the fuel tank to replace the sending units and/or fuel pump.

CAUTION: In some vehicles, the sending units/fuel pump is mounted lower than the top of the fuel tank. A fuel spill will be encountered if the fuel is not drained.

NOTE: Consult the BMW Service Workshop Equipment for the proper evacuation equipment. The saddle type tank requires an additional step to drain the fuel from the driver side. The evacuation equipment should be attached to the tank compensating hose (arrow) to drain out the remaining fuel.

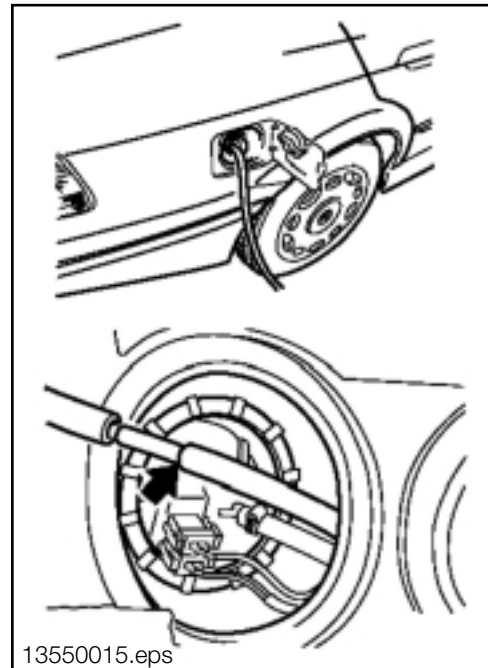

Fuel Pump/Pressure Regulator - Testing

The fuel pump should be tested for delivery pressure and volume. **Caution** when disconnecting fuel hoses because there is the possibility of residual fuel pressure! Install the fuel pressure adapter and DISplus pressure sensing lead to the fuel pressure fitting *DISplus starts with atmospheric pressure as the base.

Remove the fuel pump relay (Z3 located in the Electronics Box, E46 located behind the glove box and E39 right side of the trunk - see relay testing in the power supply section) and connect the Relay Bypass Switch to pin 87b and 30 of the relay socket. This will activate the fuel pump without running the engine.

If the 3.5 (*+ atmosphere DISplus base starting point) bar fuel pressure is not achieved or bleed off is more than 0.5 bar, refer to **13 31 of the Repair instructions** for further diagnosis. The Fuel Hose Clamp Tool can be used to isolate bleed off from the pump (non-return check valve) or the pressure regulator (restriction valve). Also verify power supply to the fuel pump.

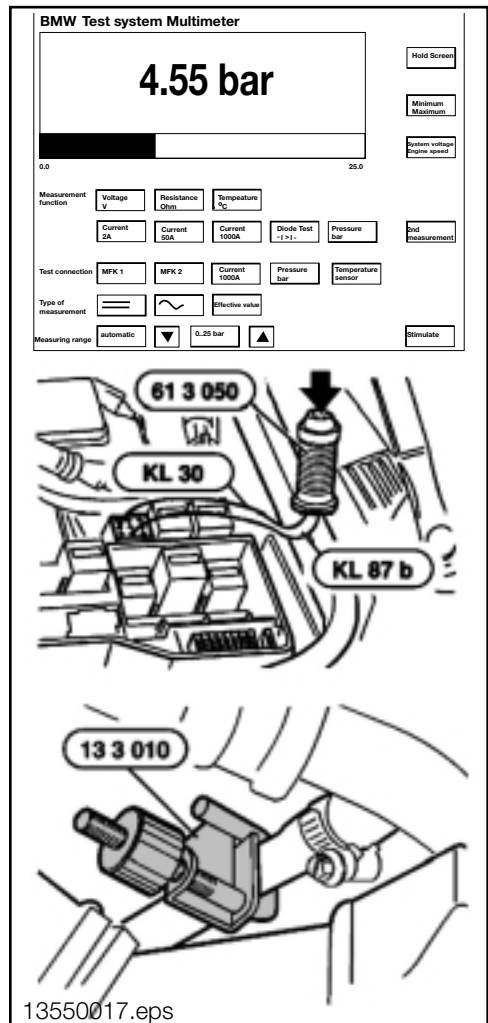

Fuel volume must be tested to verify:

- **Fuel Pump Output**
- **Restriction are not present in the pump pickup lines/hoses and fuel filter**

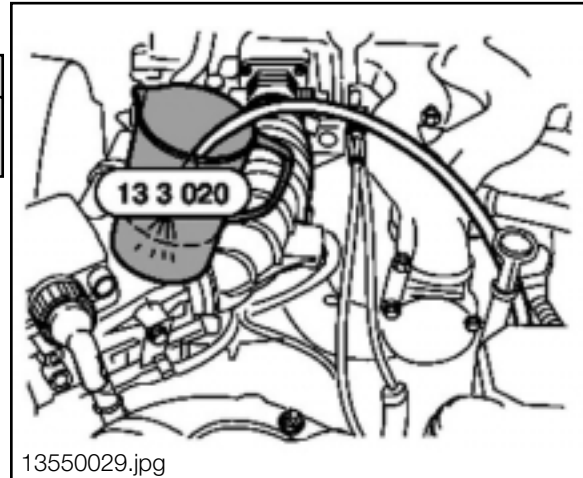

13550029.jpg

Fuel Injectors

When inspecting the fuel injectors, consider the following:

- **O-rings should be replaced, lubricated with Vaseline or SAE 90 gear oil for installation**
- **Verify the code number (different engine applications)**
- **Plastic spacer washer is not damaged**
- **Color code of housing (different engine applications)**

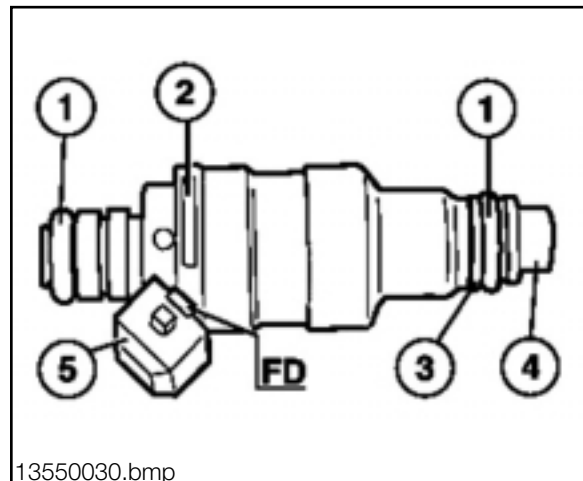

13550030.bmp

Fuel injectors can leak which bleeds off fuel pressure and increases emissions. The injectors can be tested using the Fuel Injector Leakage Tester.

The fuel injectors can be cleaned, refer to Service Information Bulletin S.I. #04 07 86.

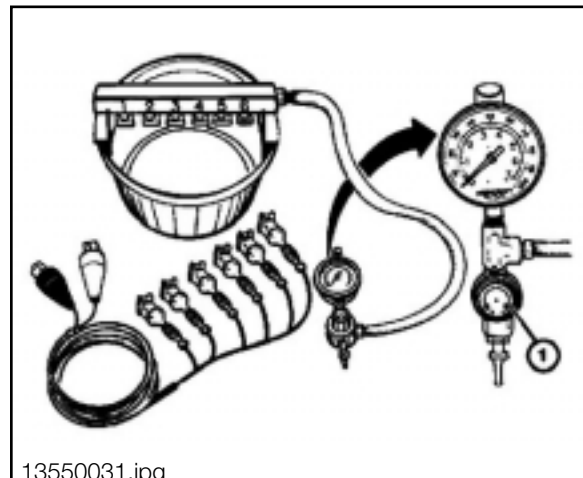

13550031.jpg

The Fuel Injectors should also be tested using the DISplus/MoDIC for:

- Resistance
- Power Supply
- Status Display - Fuel Injection Signal (approximate 3.5 - 5 ms)
- ECM Final Stage transistor activation. This test function is found under the Oscilloscope Preset list - "Ti Injection Signal". Install the Universal Adapter, Diagnostic cable, MFK 2 negative lead to ECM ground and MFK 2 positive lead to the ground activation circuit for the injector. This test is performed with the engine cranking or running.

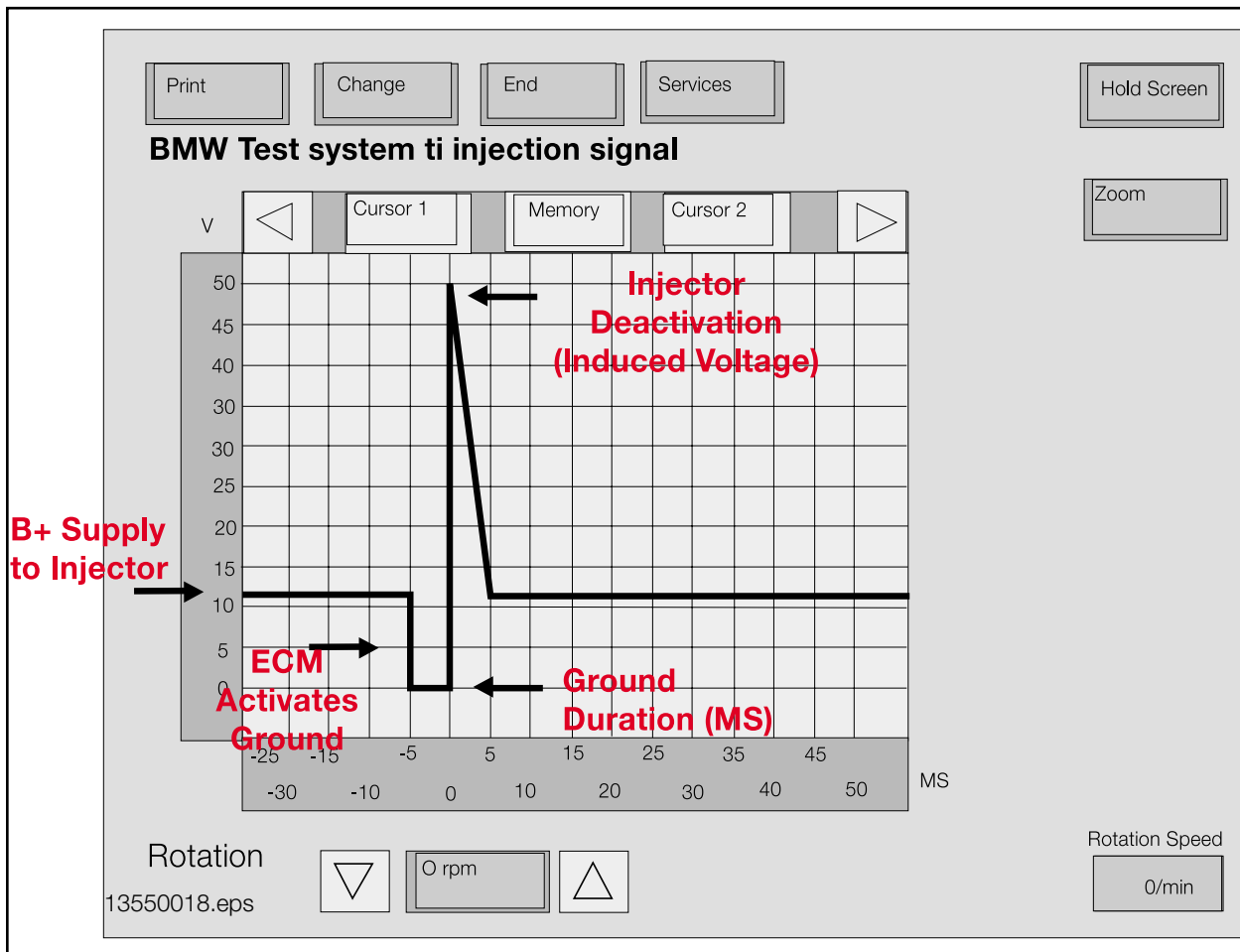
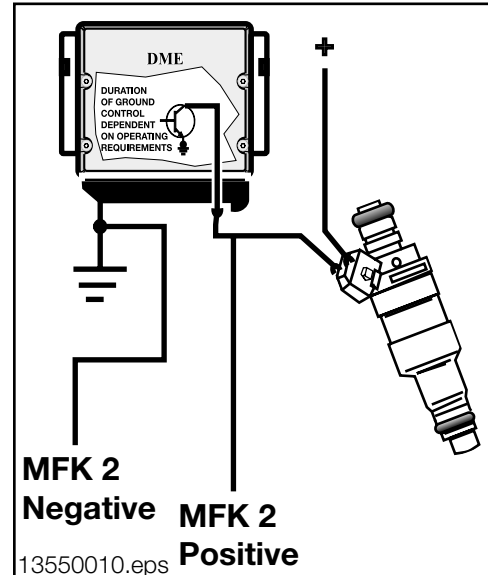

Crankshaft Position/RPM Sensor

This sensor should be tested using the DISplus/MoDIC for:

- Power Supply
- DC Voltage
- Status Display
- Oscilloscope Display found under Preset Measurements - "Engine Speed Sensor Signal"

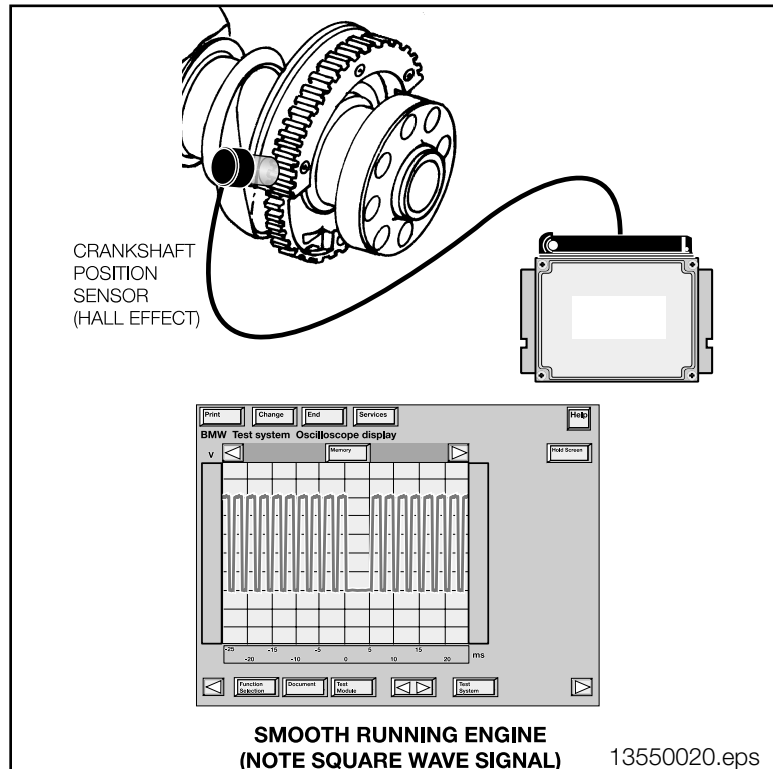

Engine Coolant Temperature

NTC sensors decrease in resistance as the temperature rises and vice versa. The ECM monitors the sensor voltage which varies as temperature changes the resistance value. For example, as temperature rises:

- Resistance through the sensor decreases
- Voltage drop of the sensor decreases
- Input signal voltage also decreases (5-0v)

The Sensor should be tested using:

- DISplus/Modic Status page degrees C (dependent on engine temperature).
- DISplus/Modic Multimeter ECM input 2.250 K ohms at 20° C Temp. Gauge input 6.7 K ohms at 20° C

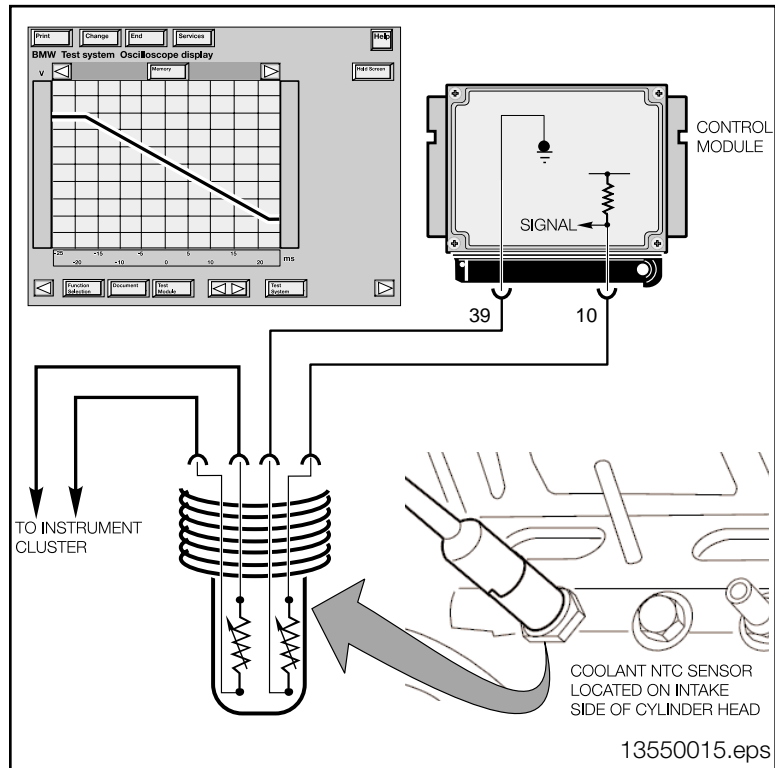

Tools and Equipment

The DISplus/Modic as well as a reputable hand held multimeter can be used when testing inputs/components.

It is best to make the checks at the ECM connection, this method includes testing the wiring harness.

The correct Universal Adapter for the MS42/MS43 application should be used (#90 88 6 121 300). This will ensure the pin connectors and the harness will not be damaged.

When installing the Universal Adapter to the ECM (located below the windshield on the passenger side of the engine compartment), make sure the ignition is switched off.

NOTE for MS43: Allow at least 3 minutes to elapse after the key was set to the "OFF" position before disconnecting the ECM/TCM. This will allow sufficient time to complete the DM TL test. Voltage may be present (up to 3 minutes) causing damage to the ECM/TCM if they are disconnected during this time period (arcing).

The Fuel Hose Clamp Tool (#13 3 010) can be used for isolating pressure faults. In addition, fuel loss can be reduced when changing the fuel filter while loosening clamps (1 and 2).

The Relay Bypass Switch (#61 3 050) must be used especially **when fuel vapors are present!** The switch eliminates the risk of electrical arcing.

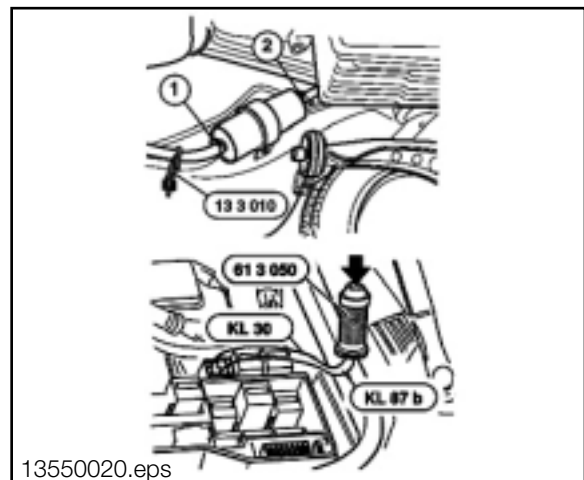
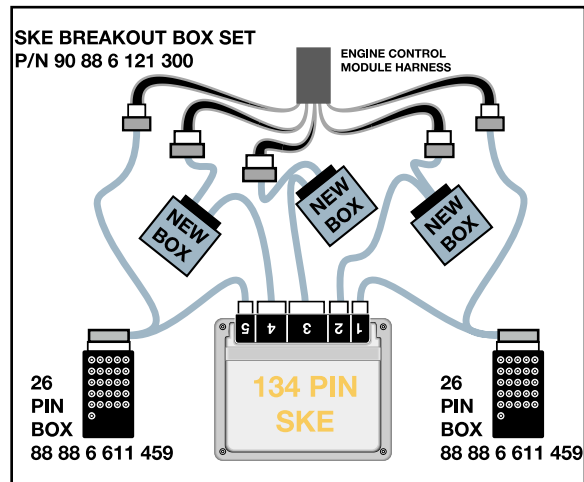
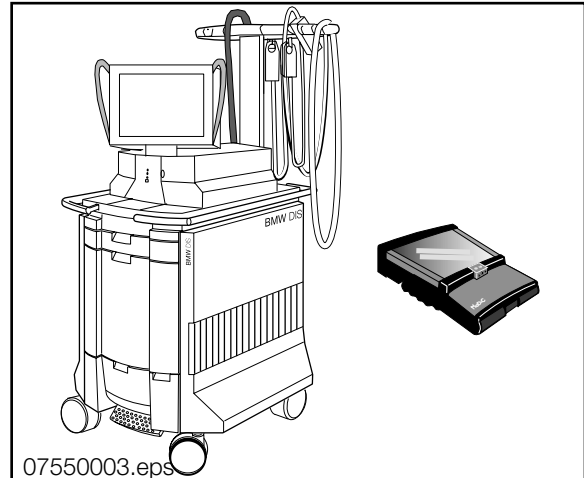

When testing fuel pressure, the hand held fuel pressure gage (#13 3 060) can be used.

Caution: Residual fuel pressure may be present!

The DISplus is equipped with a pressure measuring function, found in Measurement testing. The following adapters (Special Tool numbers) will be necessary:

- #13 6 051 • #13 6 055 • #13 6 057

These adapters install “in line” in the fuel pressure hose.

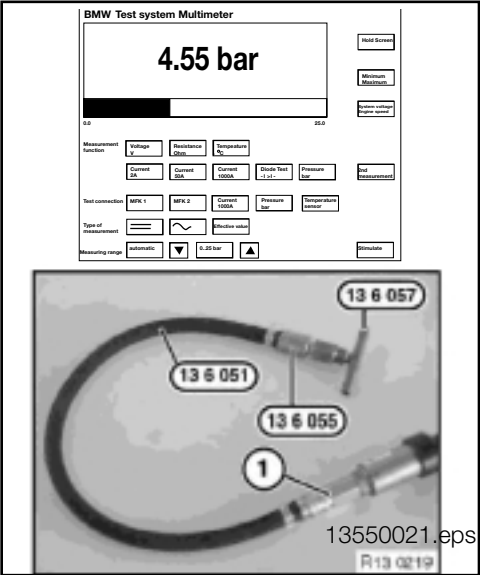

For vehicles equipped with “quick-release” couplings, install special tool (#13 5 270) between the fuel filter (1) and pressure supply hose (2). This tool will couple to the DISplus Pressure Adapter (3).

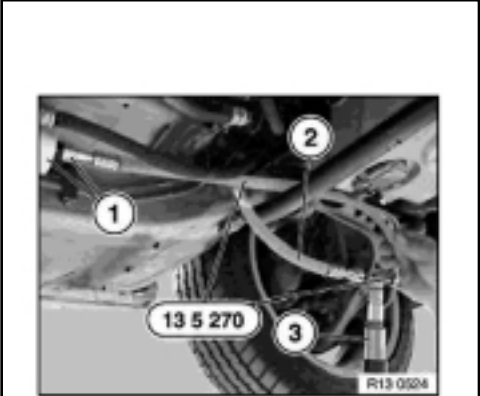

Later production fuel rails are equipped with a threaded adapter fitting (1).

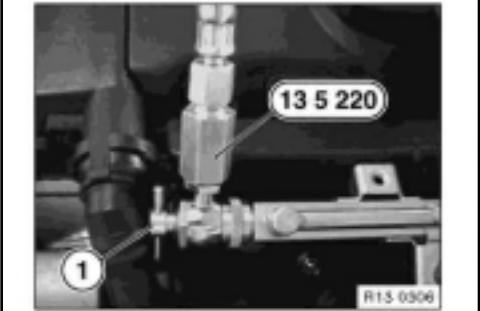

This threaded adapter fitting allows Adapter #13 5 220 to be threaded on to the fuel rail and coupled to the DISplus Pressure Adapter.

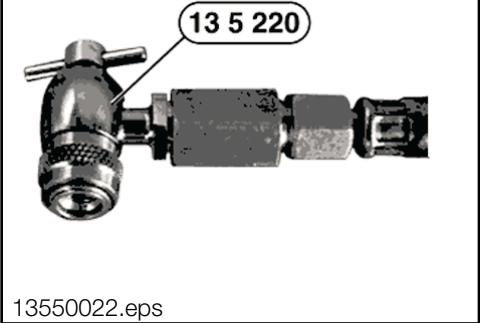

When testing the fuel injectors for leakage, use Special Tool #88 88 5 000 362. Leak testing the fuel injectors is one of the diagnostic steps listed in "Long Cranking Times" S.I. #13 08 90 (3096). This tool pressurizes the injectors with air and the injector tips are submerged in water. If air bubbles are present, this indicates the leaking injector(s).

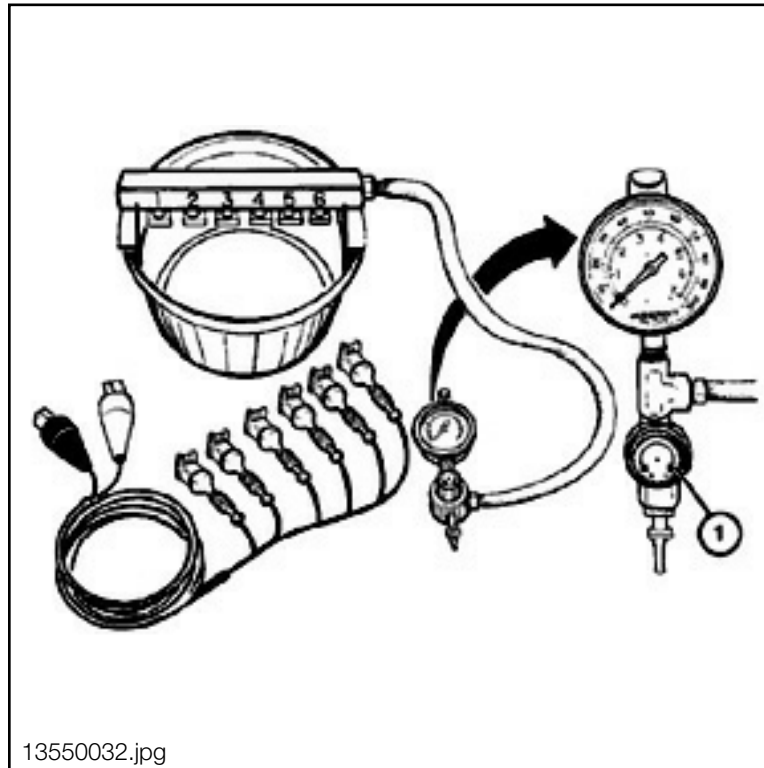

Ignition Management

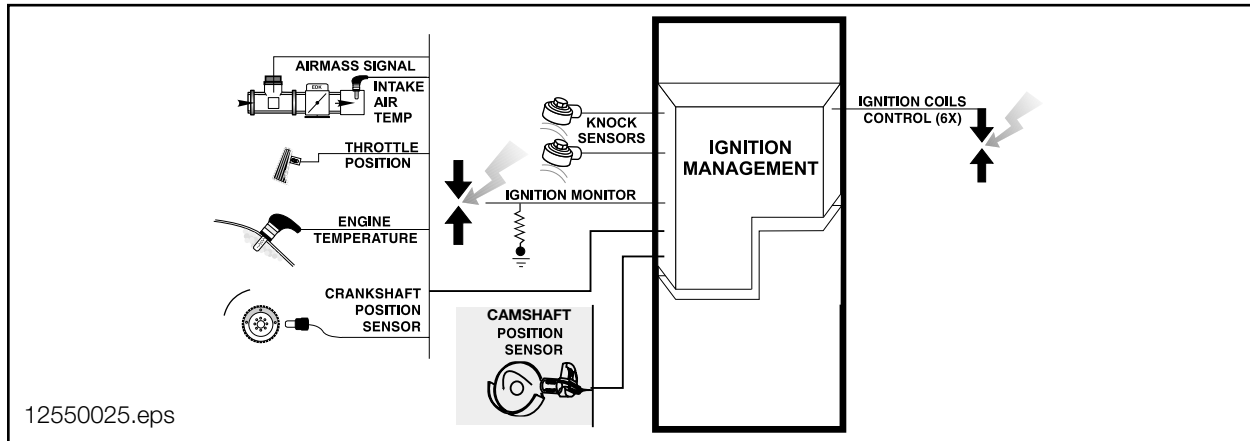

Ignition Coils: The high voltage supply required to ignite the mixture in the combustion chambers is determined by the stored energy in the ignition coils. The stored energy contributes to the ignition duration, ignition current and rate of high voltage increase. The Coil circuit including primary and secondary components consists of:

1. Coil Assembly
 - Primary Winding
 - Secondary Winding
2. Resistor (Boot Connector)
3. Spark Plug
4. ECM Final Stage Transistor
5. Secondary Coil Ground with 235 ohm Resistor

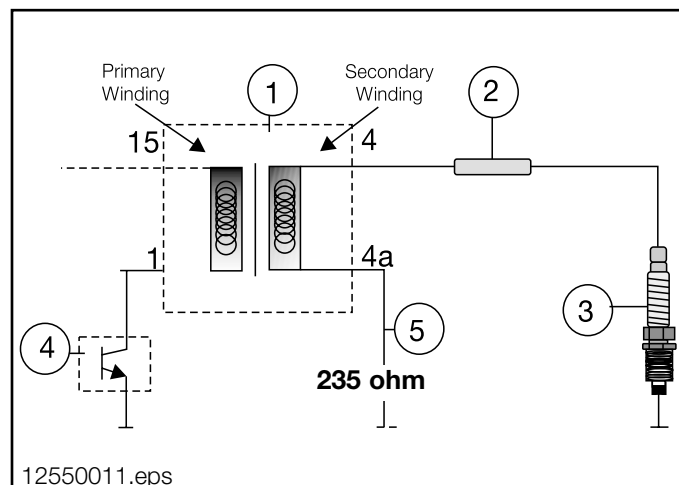

The Coil Assembly contains two copper windings insulated from each other. One winding is the primary winding, formed by a few turns of thick wire. The secondary winding is formed by a great many turns of thin wire.

The primary winding receives battery voltage from the Ignition Coil Power Relay which is activated by the ignition switch KL15. The ECM provides a ground path for the primary coil (Terminal 1) by activating a Final Stage transistor. The length of time that current flows through the primary winding is the “dwell” which allows the coil to “saturate” or build up a magnetic field. After this storage process, the ECM will interrupt the primary circuit at the point of ignition by deactivating the Final Stage transistor. The magnetic field built up within the primary winding collapses and induces the ignition voltage in the secondary winding.

The voltage generated in the secondary winding is capable of 40,000 volts (40 KV). The high voltage is discharged (Terminal 4) through the secondary ignition spark plug connector (boot) to the spark plug.

The primary and secondary windings are uncoupled, therefore, the secondary winding requires a ground supply (Terminal 4a).

The secondary grounds through a “shunt resistor” (approximately 235 ohms). The secondary ground is also supplied to the ECM which allows monitoring of secondary ignition. The resistor is located in the wiring tray on top of the cylinder head cover.

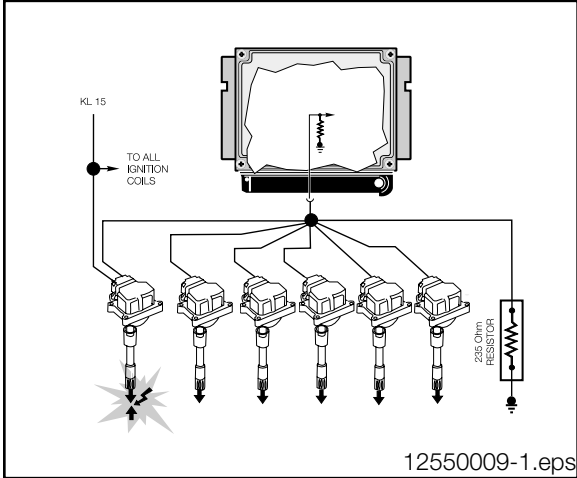

As the secondary magnetic field collapses, a voltage spike is induced in the windings. The ECM monitors the voltage drop across the resistor as an indication of coil firing. After the ECM activates the primary ignition, this feedback signal (**Terminal 4a Signal**) is confirmation that secondary ignition took place. The ECM measures the duration of time it takes the voltage drop for each ignition coil to dissipate below two volts. The time scale constantly changes based on engine rpm.

- If the 2 volt signal is not maintained long enough, the ECM detects a weak spark.
- If the feedback signal is not present (0 volts) ignition did not take place.

If the signal is missing, an ignition coil fault will be set for that cylinder. If multiple signals are missing, a feedback circuit fault will be set. If the ground circuit is defective, a ground fault will be set.

There is an individual ignition circuit and coil for each cylinder on the MS42/MS43 systems.

The six individual ignition coils (1) are coupled to spark plug connectors (2) which contain a resistor. The assemblies are mounted on top of the cylinder head cover.

There are two manufactures of ignition coils: Bremi and Bosch.

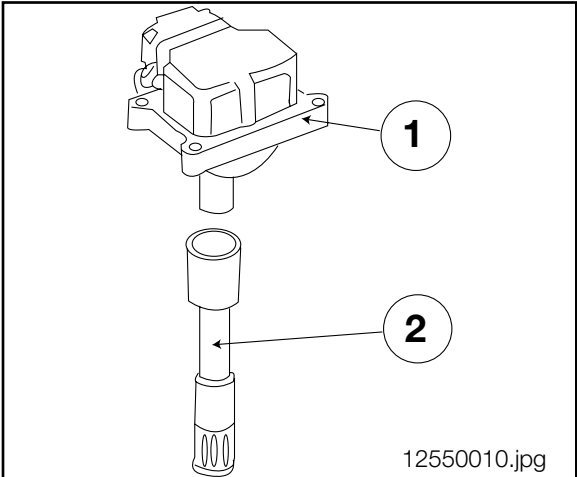

Spark Plugs: The spark plugs introduce the ignition energy into the combustion chamber. The high voltage “arcs” across the air gap in the spark plug from the positive electrode to the negative electrode. This creates a spark which ignites the combustible air/fuel mixture.

The spark plugs are located in the center of the combustion area (on the top of the cylinder head) which is the most suitable point for igniting the compressed air/fuel mixture.

Note: The High Performance Platinum Spark Plugs are approved for use.

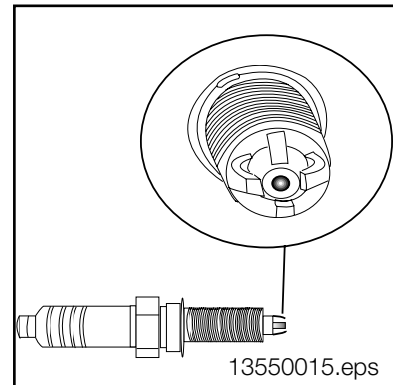

- **NGK BKR6EQUP (quad electrode, non-adjustable gap)**

Faults with the Ignition Output Components are monitored by the ECM. If there are faults with the ignition coil(s) output and/or spark plugs, the following complaints could be encountered:

• “Malfunction Indicator Light” With Mixture Related Fault Codes
• Poor Engine Performance
• Engine Misfire
• No Start/Hard Starting
• Excessive Exhaust Emissions/Black Smoke

The **ignition** is monitored by the ECM via the secondary ignition feedback circuit and Crankshaft Position/RPM Sensor. If a Misfire fault is present, the “Malfunction Indicator Light” will illuminate when the OBD II criteria is achieved and the ECM will deactivate the corresponding fuel injector for that cylinder. Engine operation will still be possible.

The Ignition Output Components must be individually tested (see Workshop Hints).

Knock Sensors: are required to prevent detonation (pinging) from damaging the engine. The Knock Sensor is a piezoelectric conductor-sound microphone. The ECM will retard the ignition timing (cylinder selective) based on the input of these sensors. Detonation can occur due to:

• High Compression Ratio	• Maximum Timing Advance Curve
• Poor Quality Fuel (Octane Rating)	• High Intake Air and Engine Temperature
• High Level of Cylinder Filling	• Carbon Build-Up (Combustion Chamber)

The Knock Sensor consists of:

1. Shielded Wire
2. Cup Spring
3. Seismic Mass
4. Housing
5. Inner Sleeve
6. Piezo-Ceramic Element

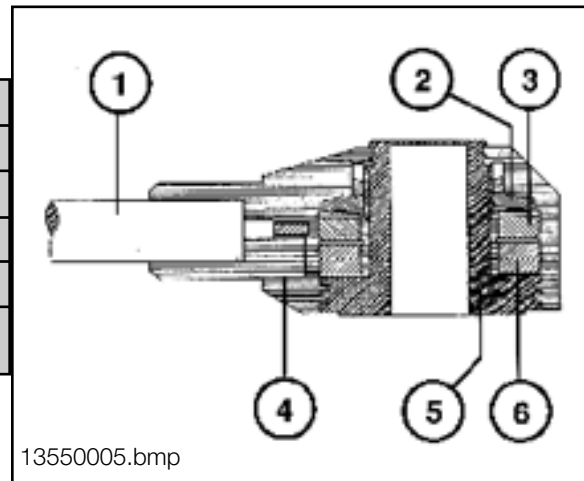

A piezo-ceramic ring is clamped between a seismic mass and the sensor body. When the seismic mass senses vibration (flexing), it exerts a force on the piezo-ceramic element. Opposed electrical charges build up on the upper and lower ceramic surfaces which generates a voltage signal. The acoustic vibrations are converted into electrical signals. These low voltage signals are transmitted to the ECM for processing.

There are two Knock Sensors bolted to the engine block on the intake manifold side, (1) between cylinders 1 - 3 and (2) between cylinders 4 - 6. If the signal value exceeds the threshold, the ECM identifies the “knock” and retards the ignition timing for that cylinder.

If a fault is detected with the sensor(s), the ECM deactivates Knock Control. The “Malfunction Indicator Light” will be illuminated when the OBD II criteria is achieved, the ignition timing will be set to a conservative basic setting and a fault will be stored.

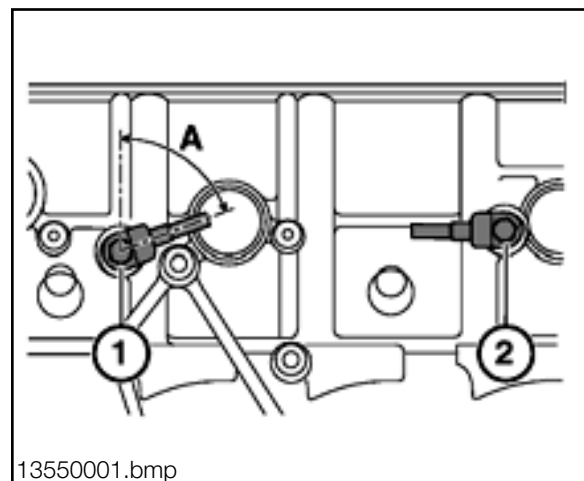

Crankshaft Position/RPM Sensor: This sensor provides the crankshaft position and engine speed (RPM) signal to the ECM for ignition activation and correct timing. This input is also monitored for Misfire Detection. For details about the sensor, refer to the Fuel Management section.

A fault with this input will produce the following complaints:

- **No Start**
- **Intermittant Misfire/Driveability**
- **Engine Stalling**

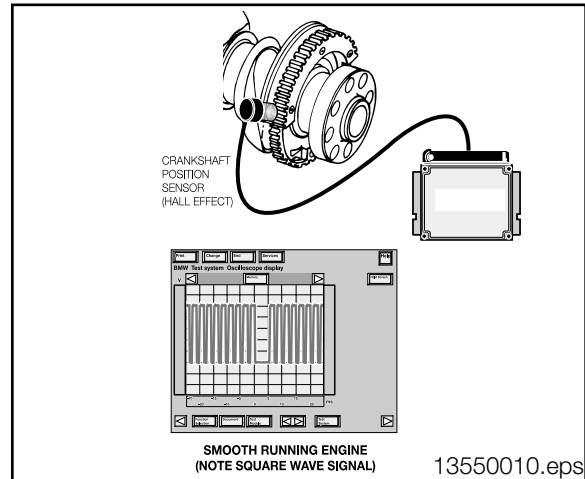

Camshaft Position Sensors (Cylinder Identification): The cylinder ID sensor input allows the ECM to determine camshaft position in relation to crankshaft position. It is used by the ECM to establish the “working cycle” of the engine for precise ignition timing. For details about the sensor, refer to the Fuel Management section.

If the ECM detects a fault with the Cylinder ID Sensor, the “Malfunction Indicator Light” will be illuminated when the OBD II criteria is achieved and the system will still operate precise **single ignition** based on the Crankshaft Position/RPM Sensor.

If the signal is impaired during a restart, the ECM will activate “**double ignition**”. The ignition coils will be activated on both the compression and exhaust strokes to maintain engine operation.

Engine Coolant Temperature: The ECM determines the correct ignition timing required for the engine temperature. For details about the sensor, refer to the Fuel Management section. This sensor is located in the coolant jacket of the cylinder head (left rear).

If the Coolant Temperature Sensor input is faulty, the “Malfunction Indicator Light” will be illuminated when the OBD II criteria is achieved and the ECM will assume a substitute value (80° C) to maintain engine operation. The ignition timing will be set to a conservative basic setting.

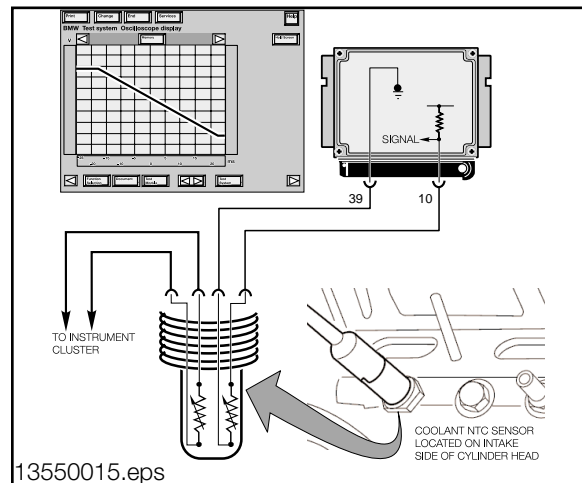

Hot-Film Air Mass Meter: This input is used by the ECM to determine the amount of ignition timing advance based on the amount of intake air volume. For details about the sensor, refer to the Air Management section.

If this input is defective, a fault code will be set and the “Malfunction Indicator Light” will illuminate when the OBD II criteria is achieved. The ECM will maintain engine operation based on throttle position and the Engine Speed Sensor, and the ignition timing will be set to a conservative basic setting.

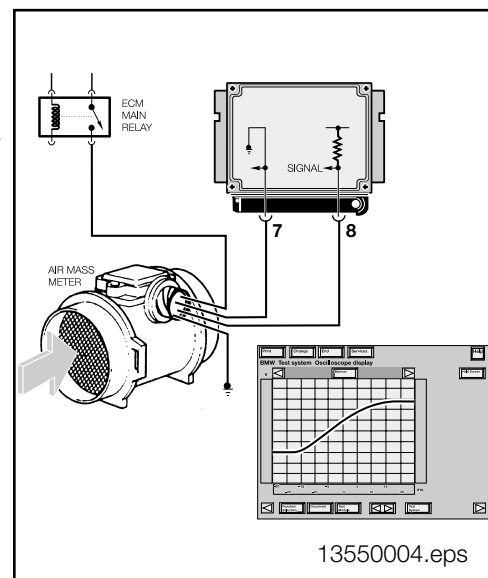

Throttle Position: This provides the ECM with accelerator pedal position and rate of movement. As the accelerator pedal is depressed the ECM will advance the ignition timing. The “full throttle” position indicates maximum acceleration to the ECM, the ignition will be advanced for maximum torque. For details about the sensor, refer to the Air Management section.

Air Temperature: This signal allows the ECM to make a calculation of air density. For details about the sensor, refer to the Air Management section.

The ECM will adjust the ignition timing based on air temperature. If the intake air is hot the ECM retards the ignition timing to reduce the risk of detonation. If the intake air is cooler, the ignition timing will be advanced.

If this input is defective, a fault code will be set and the “Malfunction Indicator Light” will illuminate when the OBD II criteria is achieved. The ignition timing will be set to a conservative basic setting.

Principle of Operation

Ignition Management provides ignition to the combustion chambers with the required voltage at the correct time. Based on the combination of inputs, the ECM calculates and controls the **ignition timing** and **secondary output voltage** by regulating the activation and dwell of the **primary ignition circuits**. The ECM controls and monitors the secondary ignition output including **Misfire Detection**.

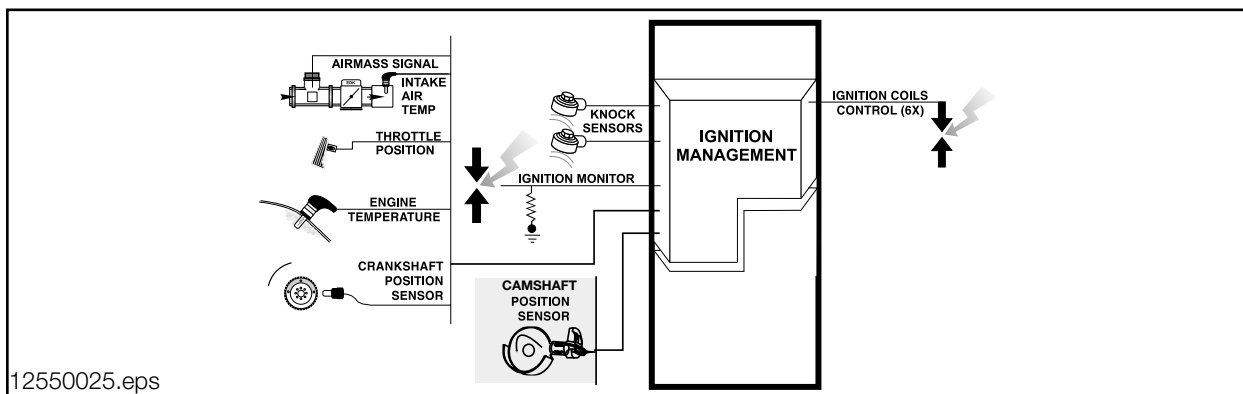

The ECM has a very “broad” range of ignition timing. This is possible by using a Direct Ignition System, or sometimes referred to as “Static Ignition System” (RZV). Reliability is also increased by having separate individual ignition circuits.

The Ignition Control is determined by the ECM (load dependant). The ECM will calculate the engine “load” based on a combination of the following inputs:

• Battery Voltage	• Accelerator Pedal Position	• Air Flow Volume
• Air Temperature	• Engine Coolant	• Crankshaft Position/RPM
• Camshaft Positions (Cylinder ID)	• Knock Sensors	

The dwell time will be regulated based on battery voltage. When cranking, the voltage is low and the ECM will increase the dwell to compensate for saturation “lag time”. When the engine is running and the battery voltage is higher, the ECM will decrease the dwell due to faster saturation time.

The Crankshaft Position/RPM signals the ECM to start ignition in firing order (1-5-3-6-2-4) as well as providing information about the engine operation. This input is used in combination with other inputs to determine engine load which advances/retards the ignition timing. Without this input, the ECM will not activate the ignition.

Cold start is determined by the ECM based on the engine coolant temperature and rpm during start up. A cold engine will crank over slower than a warm engine, the ignition timing will range between top dead center to slightly retarded providing optimum starting.

When starting a warm engine, the rpm is higher which results in slightly advanced timing.

If the engine coolant and intake air temperature is hot, the ignition timing will not be advanced reducing starter motor "load".

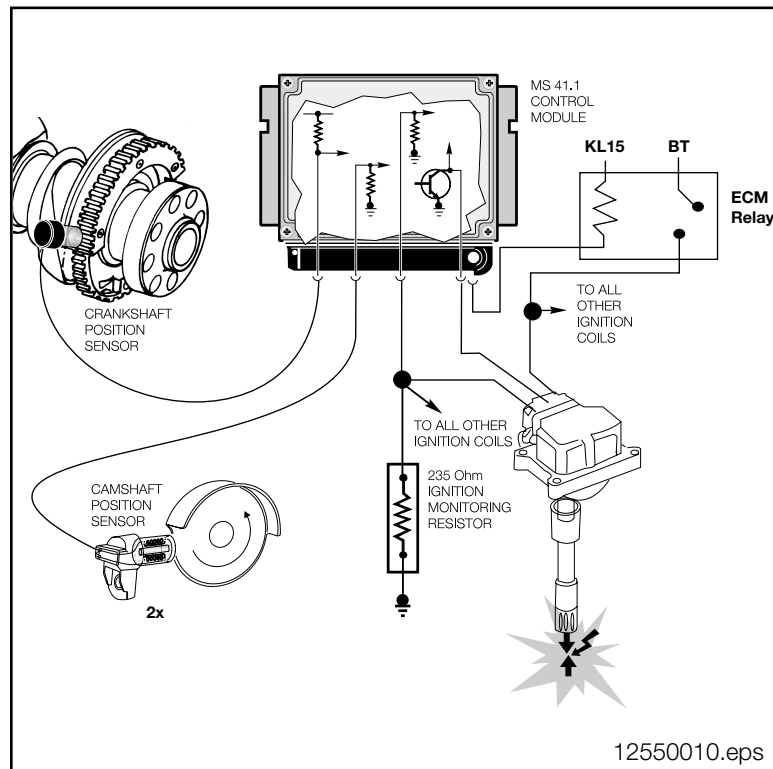

Multiple Ignition Pulses ensure good spark quality during engine start up. The ECM will activate the ignition coils 9 times (voltage dependent) per 720° of crankshaft revolution.

The ignition timing will be progressively advanced assisting the engine in coming up to speed. As the engine speed approaches idle rpm, the timing remains slightly advanced to boost torque. When the engine is at idle speed, minimum timing advance is required. This will allow faster engine and catalyst warm up.

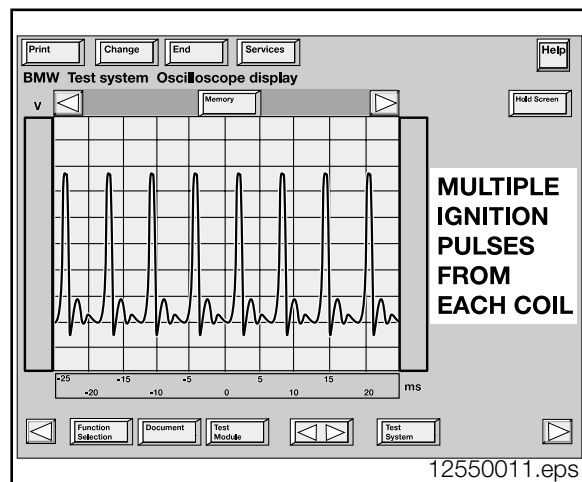

The multiple pulsing switches to single pulse when:

- **Engine Speed >1350 RPM (varied with engine temperature)**

The timing will be advanced when the ECM observes low engine rpm and increasing throttle/air volume inputs (acceleration torque). As the throttle is opened, the ECM advances the timing based on engine acceleration and at what rate. The ECM will fully advance timing for the "full throttle" position indicating maximum acceleration (torque).

MS43 Emission Optimized - Ignition Key Off

“Emission Optimized Ignition Key Off” is a programmed feature of the MS43 ECM.

After the ECM detects KL15 is switched “off”, the ignition stays active (ECM Relay/voltage supply) for two more individual coil firings.

This means that just two cylinders are fired - not two revolutions.

This feature allows residual fuel injected into the cylinders, as the ignition key is switched off, to be combusted as the engine runs down.

EMISSION OPTIMIZED IGNITION KEY OFF

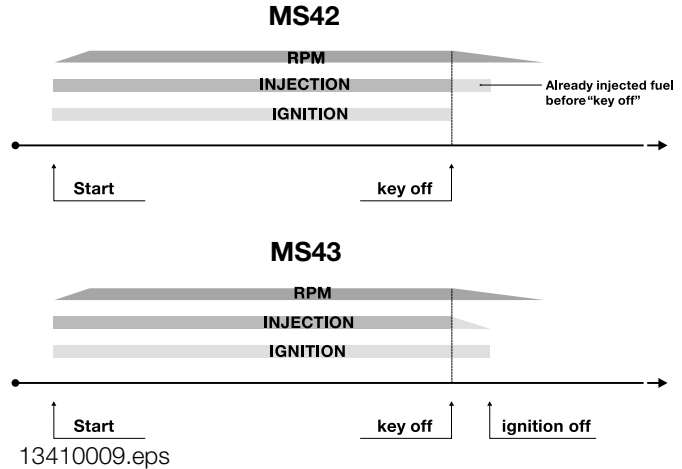

When **KL15** is switched “off” the ECM operating voltage is removed.

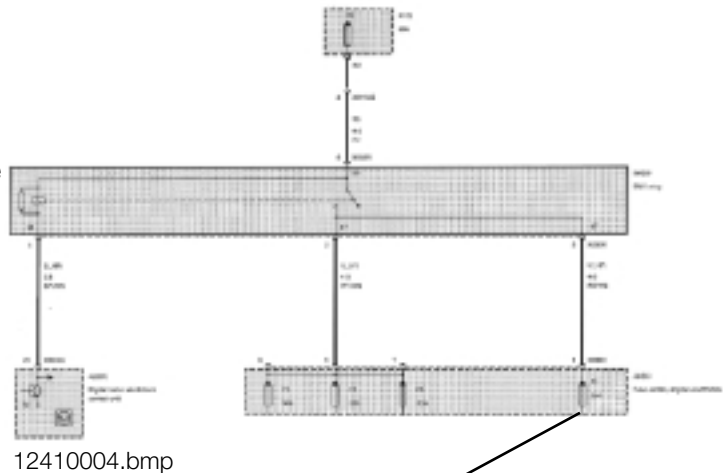

The ECM will maintain a ground to the Engine Control Module Relay for a few seconds to maintain ignition coil activation.

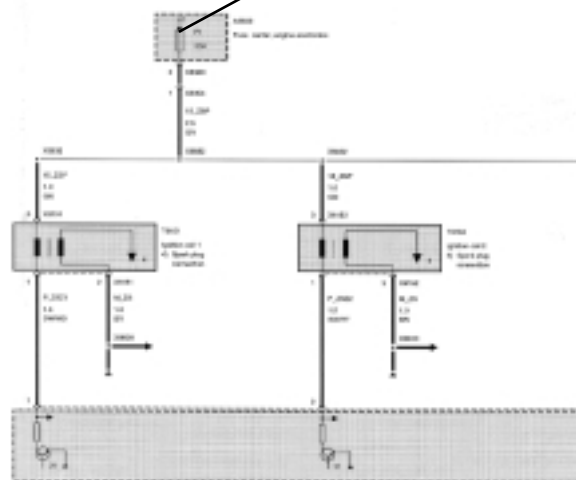

The HFM signal represents the amount of intake air volume. This input is used by the ECM to determine the amount of timing advance to properly combust the air/fuel mixture.

The Air Temperature Signal assists the ECM in reducing the risk of detonation (ping). If the intake air is hot the ECM retards the ignition timing. If the intake air is cooler, the ignition timing will be advanced.

As the throttle is closed, the ECM decreases the ignition timing if the rpm is above idle speed (coasting). This feature lowers the engine torque for deceleration. When the engine rpm approaches idle speed, the timing is slightly advanced to prevent the engine from stalling. The amount of advance is dependent upon the engine temperature and the rate of deceleration.

Knock Control allows the ECM to further advance the ignition timing under load for increased torque. This system uses two Knock Sensors located between cylinders 1,2,3 and between cylinders 4,5,6. Knock Control is only in affect when the engine temperature is greater than 35 °C and there is a load on the engine. This will disregard false signals while idling or from a cold engine.

Based on the firing order, the ECM monitors the Knock Sensors after each ignition for a normal (low) signal.

If the signal value exceeds the threshold, the ECM identifies the “knock” and retards the ignition timing (3°) for that cylinder the next time it is fired. This process is repeated in 3° increments until the knock ceases.

The ignition timing will be advanced again in increments to just below the knock limit and maintain the timing at that point.

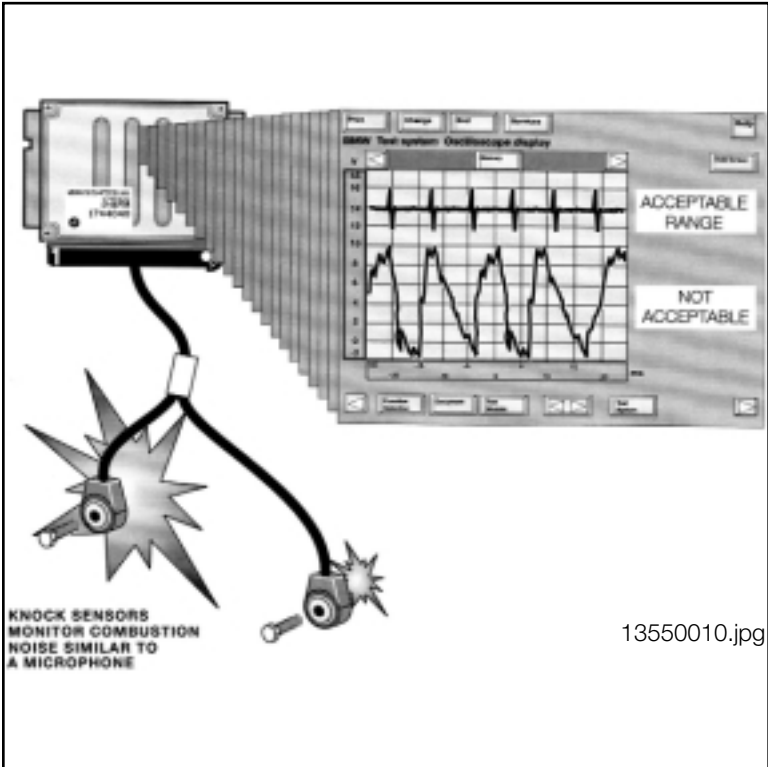

If a fault is detected with the Knock Sensor(s) or circuits, the ECM deactivates Knock Control. The ignition timing will be set to a conservative basic setting (to reduce the risk of detonation) and a fault will be stored. The “Malfunction Indicator Light” will be illuminated when the OBD II criteria is achieved.

Workshop Hints

Before any service work is performed on any ignition system related component, always adhere to the following:

- | |
|---|
| • Observe relevant safety legislation pertaining to your area |
| • Always wear adequate protection clothing including eye protection. |
| • Use caution when working around a HOT engine compartment. |
| • Always consult the REPAIR INSTRUCTIONS on the specific model you are working on before attempting a repair. |
| • Always SWITCH OFF THE IGNITION (KL15) before working on the ignition system. |
| • Use only BMW approved test leads. |
| • NEVER TOUCH COMPONENTS CONDUCTING CURRENT with the engine running. |
| • Do not connect suppression devices or a “test light” to terminal 1 of the ignition coils. |
| • Terminal 1 from the ignition coil to the ECM (High Voltage approximately 350 V) |

HIGH VOLTAGE - DANGER!

Caution! Hazardous voltages occur at:

- | |
|--|
| • Ignition Leads |
| • Spark Plug Connector |
| • Spark Plug |
| • Ignition Coil (High Voltage at terminal 4 is approximately 40 KV) |
| • Terminal 1 from the ignition coil to the ECM (High Voltage approximately 350V) |

Ignition System Diagnosis

A fault survey should first be performed using the DISplus/MoDIC to determine if there is a fault in the primary ignition or secondary ignition. If there is a fault in the primary ignition, testing should include:

- **Power Supply at the Coil (KL15)**
- **Resistance of the harness and ignition coil primary winding (terminal 15 to 1 approx: 0.8 ohms) - using the Universal Adapter with the ECM disconnected**

- A. ECM Primary Circuit Final Stage Transistor**
- B. ECM Ignition Coil (one of six)**
- C. Secondary Coil Ground**

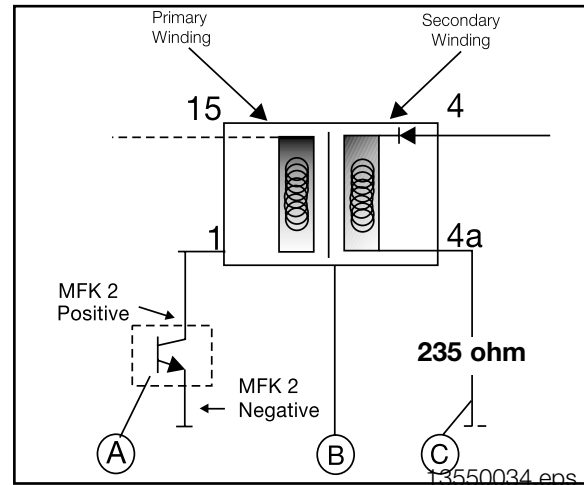

ECM Final Stage transistor activation. This test function is found under the Oscilloscope Preset list - "Ignition Signal Primary" (normal Terminal 1 Signal shown on the right).

Install the Universal Adapter, Diagnostic cable, MFK 2 negative lead to ECM ground and MFK 2 positive lead to the ground activation circuit for Terminal 1 of the ignition coil. This test is performed with the engine cranking/running.

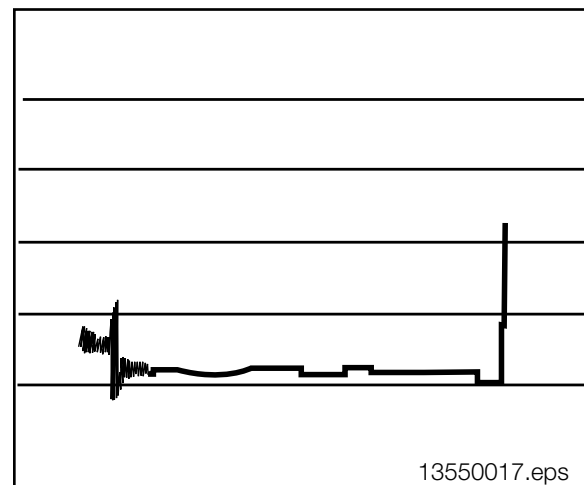

The Terminal 4a Signal should be tested using the DIS "Preset Measurements". Refer to the HELP button for additional (on screen) connections.

There is one signal present for each secondary ignition. This signal represents successful coil induction.

This Signal does not verify the adapter (boot) and spark plug is functioning correctly! Therefore additional secondary ignition testing should be performed.

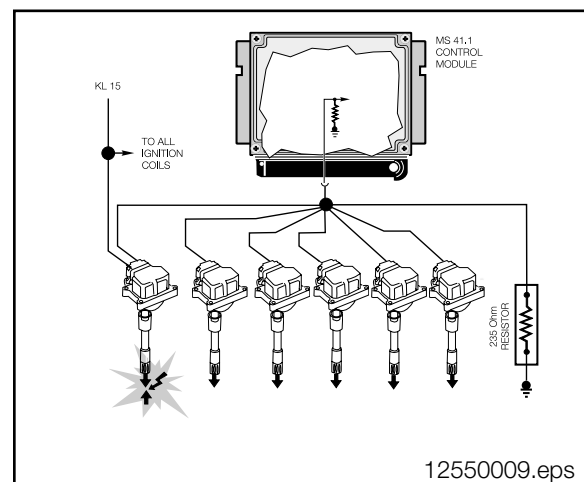

If there is a fault in the secondary ignition, testing should include:

- Primary Ignition
- Evaluation of Secondary Oscilloscope Patterns

The Following are Examples of Secondary Oscilloscope Patterns (consult Repair Instructions for ignition pattern variations per coil manufacturer):

This is a normal pattern for one ignition circuit with the engine at idle speed.

- 1. Normal Combustion Period
- 2. Normal Ignition Voltage Peak

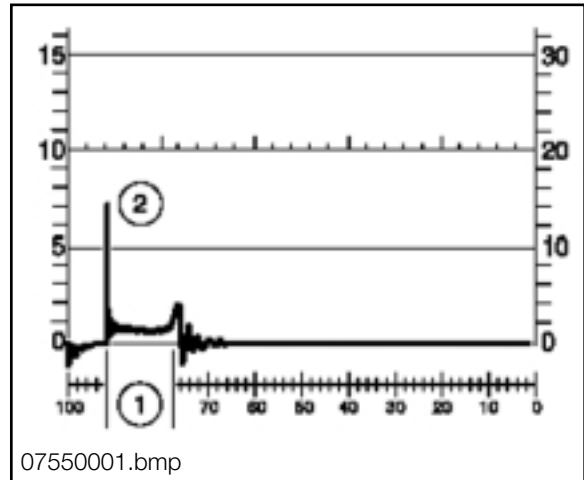

Multiple Ignition Pulses ensure good spark quality during engine start up. The ECM will activate the ignition coils 9 times per 720° of crankshaft revolution.

This is a normal pattern for one ignition circuit when:

- Engine speed <1350 RPM

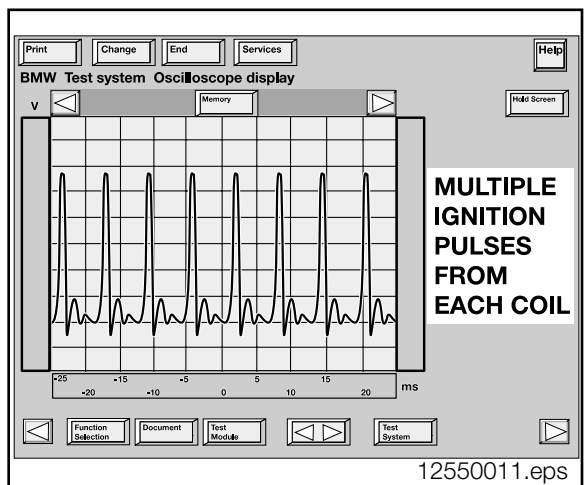

Long Spark Period (1) with Low Ignition Voltage Peak (2). If Spark Period is Fluctuating:

- Indicates Low Compression
- Contamination on Spark Plug or Defective Spark Plug

Short Spark Period (1) with High Ignition Voltage Peak (2).

- Defective Ignition Connector or Resistive Adapter Boot

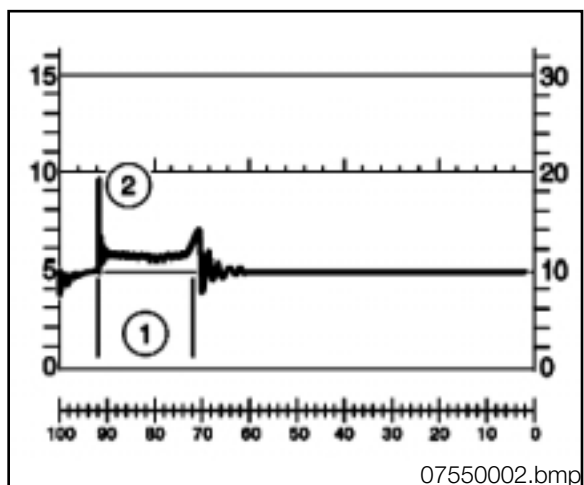

Evaluation of Ignition Voltage Peaks at Idle Speed (Multiple Cylinders Displayed).

- 1. Normal Attenuation (Voltage Reduction) Process**
- 2. Shorten Attenuation Process (arrow)-Defective Ignition Coil**
- 3. Absence of Attenuation (arrow)- Defective Ignition Coil**

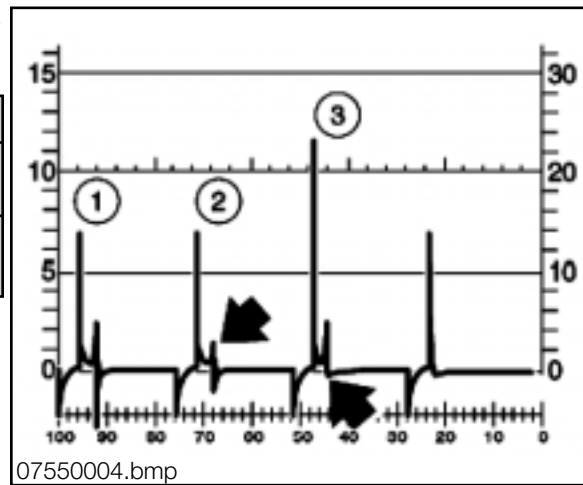

No Sparking Voltage Line (Single Cylinder Displayed)

- Defective Ignition Coil**

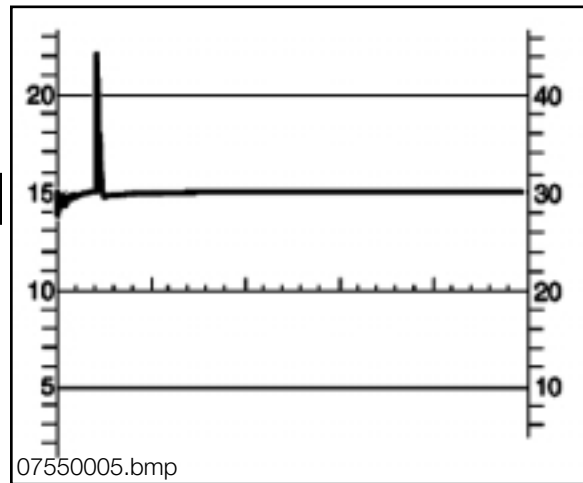

Evaluation of Ignition Voltage Peaks under Sudden Loads (Multiple Cylinders Displayed).

- 1. Decaying Process is not much Higher than Ignition Voltage Peak - System is Ok.**

Decaying Process is considerably Higher than Ignition Voltage Peak (2):

- Lean Mixture**
- Defective Fuel Injector**
- Low Compression**

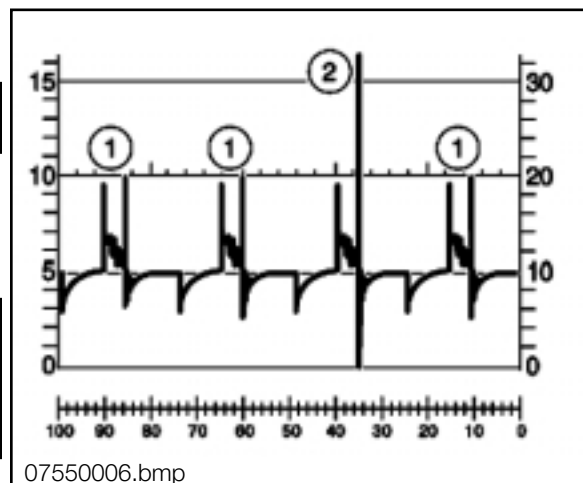

The Repair Instructions should be consulted for additional Oscilloscope Patterns under various engine speeds.

In Summary,

If the Secondary Ignition **Voltage is Too High (Excessive Resistance for Ignition):**

- | |
|---|
| • Spark Plug Gap is to Large (Worn or Burned) |
| • Incorrect Heat Range Spark Plug |
| • Compression is too High (Carbon, etc.) |
| • Lean Mixture (Vacuum Leak, etc.) |
| • Interruption in the Secondary Ignition Connector or Resistive Adapter Boot |

If the Secondary Ignition **Voltage is Too Low (Low Resistance for Ignition):**

- | |
|---|
| • Spark Plug Gap is Too Small (Mishandled on Installation) |
| • Incorrect Heat Range Spark Plug |
| • Compression is Too Low |
| • Voltage Leak in the Secondary Ignition Connector or Resistive Boot to Ground |

Spark Plugs

The Spark Plugs should be inspected for the proper type, gap and replaced at the specified intervals.

Refer to the Service Information Bulletin S.I. #12 01 99 for the proper type and a visual of the spark plug (showing effects of combustion, fouling, etc.)

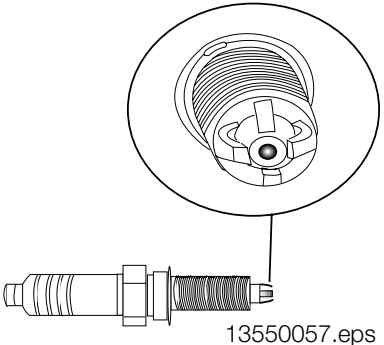

13550057.eps

Ignition Adapter (Boot)

The secondary ignition Resistive Adapter Boot should be visually inspected and checked for resistance.

For example, the Resistive Adapter Boot has a different ohmic value depending on the manufacturer:

- **Bosch** - 1k ohm +/- 20%
- **Bremi** - 1.8k ohm +/- 20%

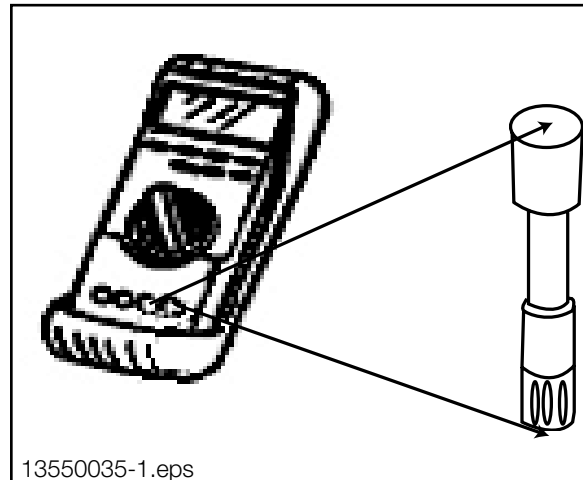

Knock Sensors

The Knock Sensors should be tested using the DIS/MoDIC for:

- **Fault Codes**
- **Status Display - Knock Control (active / not active)**
- **Oscilloscope Display (Low DC Voltage - mV setting)**

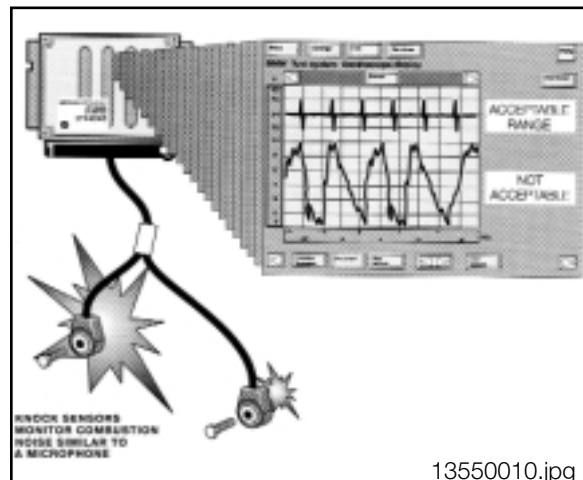

When installing Knock Sensors:

DO NOT MIX THE LOCATIONS or Engine Damage will result! The Knock Sensors use a combined connection to the engine harness. The Knock Sensor with the shorter cable is for cylinders 4 - 6.

Do Not Over Tighten attaching bolt! - Piezo ceramic will be cracked. Torque to 20 nm.

Do Not Under Tighten attaching bolt, a loose sensor can vibrate producing a similar signal to a knock.

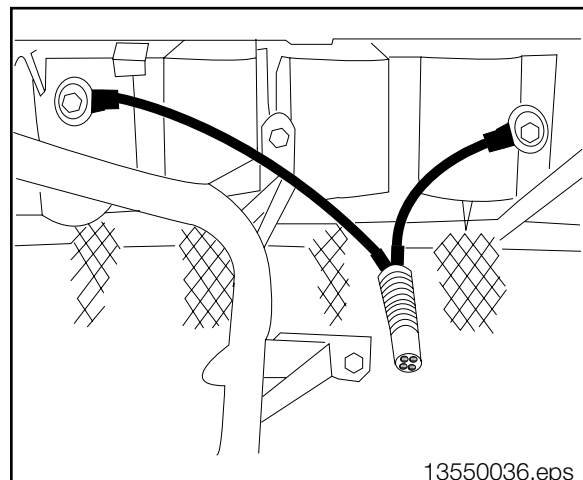

Tools and Equipment

The DISplus/Modic as well as a reputable hand held multimeter can be used when testing inputs/components.

It is best to make the checks at the ECM connection, this method includes testing the wiring harness.

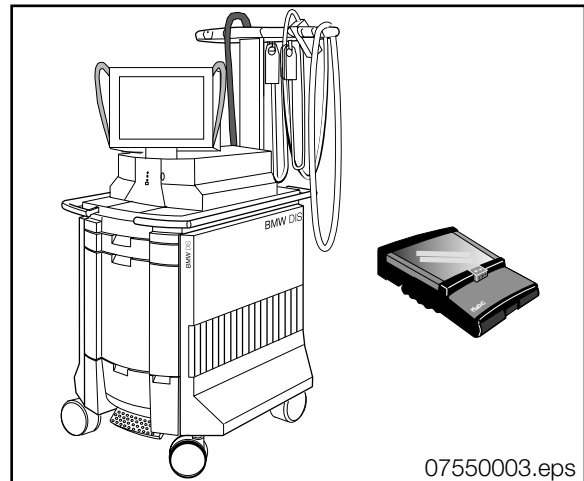

The correct Universal Adapter for the MS42/MS43 application should be used (#90 88 6 121 300). This will ensure the pin connectors and the harness will not be damaged.

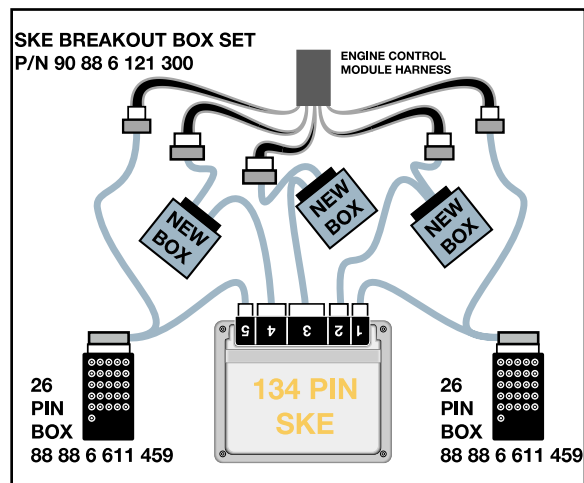

When installing the Universal Adapter to the ECM, make sure the ignition is switched off.

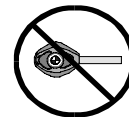

When Testing the Secondary Ignition System, use Special Tool #88 88 6 127 040 (Secondary Ignition Adapter Set shown to the right) which connects to the DIS. The instruction book is included with the kit. Refer to the HELP button for additional (on screen) connections.

Caution!

Observe Safety Precautions, High Voltage is Present with the Engine Running

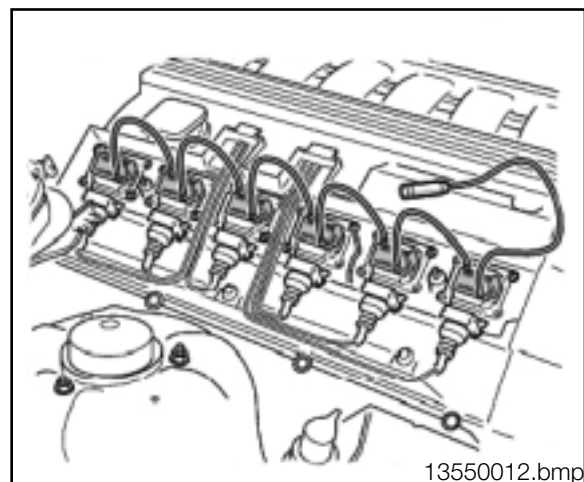

The Spark Plugs should be properly installed and torqued using the following Special Tools:

- 12 1 200 Torque Adapter
(prevents over tightening)
- 12 1 171 Spark Plug Socket

NOTE: NEVER USE AIR TOOLS FOR REMOVAL OR INSTALLATION!

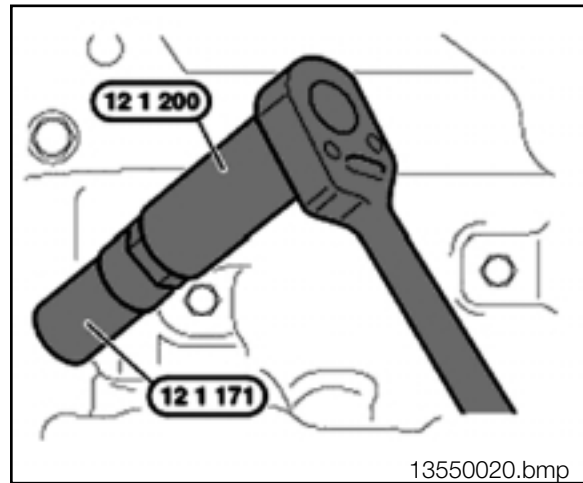

Emissions Management - Low Emission Vehicle (LEV) Compliant - M54 3.0 Liter Ultra Low Emission Vehicle (ULEV)

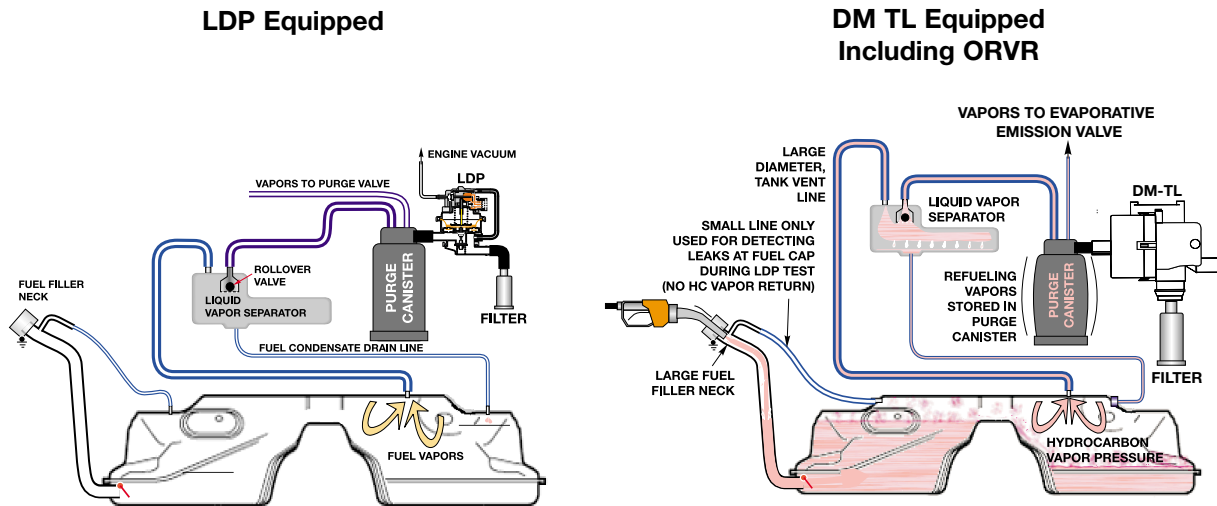

Evaporative Emissions: The control of the evaporative fuel vapors (Hydrocarbons) from the fuel tank is important for the overall reduction in vehicle emissions. The evaporative system has been combined with the ventilation of the fuel tank, which allows the tank to breath (equalization). The overall operation provides:

- An inlet vent, to an otherwise “sealed” fuel tank, for the entry of air to replace the fuel consumed during engine operation.
- An outlet vent with a storage canister to “trap and hold” fuel vapors that are produced by the expansion/evaporation of fuel in the tank, when the vehicle is stationary.

The canister is then “purged” using the engine vacuum to draw the fuel vapors into the combustion chamber. This “cleans” the canister allowing for additional storage. Like any other form of combustible fuel, the introduction of these vapors on a running engine must be controlled.

The ECM controls the Evaporative Emission Valve which regulates purging of evaporative vapors. The evaporative system must be monitored for correct purge operation and Leak Detection.

On-Board Refueling Vapor Recovery (ORVR - DM TL Equipped Vehicles): The ORVR system recovers and stores hydrocarbon fuel vapor that was previously released during refueling. Non ORVR vehicles vent fuel vapors from the tank venting line back to the filler neck and in many states reclaimed by a vacuum receiver on the filling station's fuel pump nozzle.

When refueling an ORVR equipped vehicle, the pressure of the fuel entering the tank forces the hydrocarbon vapors through the larger tank vent line to the liquid/ vapor separator, through the rollover valve and into the charcoal canister. The HC is stored in the charcoal canister, and the system can then "breathe" through the DM TL and the air filter. The vent line to the filler neck is smaller, but still necessary for checking the filler cap/neck during Evaporative Leak Testing.

Liquid/Vapor Separator: Fuel vapors are routed from the fuel tank filler neck through a hose to the Liquid/Vapor Separator. The vapors cool when exiting the fuel tank, the condensates separate and drain back to the fuel tank through a return hose. The remaining vapors exit the Liquid/ Vapor Separator to the Active Carbon Canister.

Active Carbon Cannister: As the hydrocarbon vapors enter the canister, they will be absorbed by the active carbon. The remaining air will be vented to the atmosphere through the end of the canister allowing the fuel tank to "breathe". When the engine is running, the canister is then "purged" using intake manifold vacuum to draw air through the canister which extracts the hydrocarbon vapors into the combustion chamber.

Evaporative Emission Valve: This ECM controlled solenoid valve regulates the purge flow from the Active Carbon Canister into the intake manifold. The ECM Relay provides operating voltage, and the ECM controls the valve by regulating the ground circuit. The valve is powered open and closed by an internal spring.

If the Evaporative Emission Valve circuit is defective, a fault code will be set and the "Malfunction Indicator Light" will illuminate when the OBD II criteria is achieved.

If the valve is "mechanically" defective, a drivability complaint could be encountered and a mixture related fault code will be set.

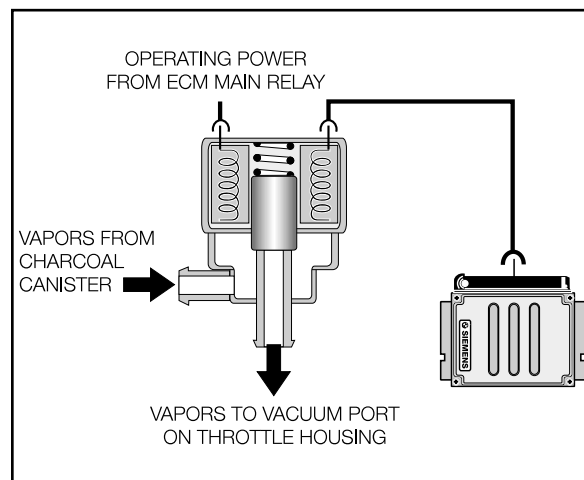

MS42 - Evaporative System Leak Diagnosis with Leakage Diagnosis Pump (LDP):

The LDP provides a means of testing the fuel/evaporative system for leaks. The pump is activated by the ECM and pressurizes the fuel tank and evaporative system.

The LDP and charcoal canister (combination) assembly is located under the right rear trunk floor on the E46 (for example). This system is capable of detecting a leak **as small as 0.5 mm.**

The LDP is a unitized component that contains the following:

- Vacuum chamber
- Pneumatic pump chamber
- DME activated vacuum solenoid
- Reed switch providing a switched voltage feedback signal to the ECM



The LDP assembly is only replaceable as a complete unitized component, however, it is separate from the charcoal canister.

The upper chamber contains an integrated reed switch that produces a switched high/low voltage signal that is monitored by the ECM.

The switch is opened by the magnetic interruption of the metal rod connected to the diaphragm when in the top dead center position.

The repetitive up/down stroke is confirmation to the ECM that the valve is functioning and the basis for determining if a leak is present in the system.

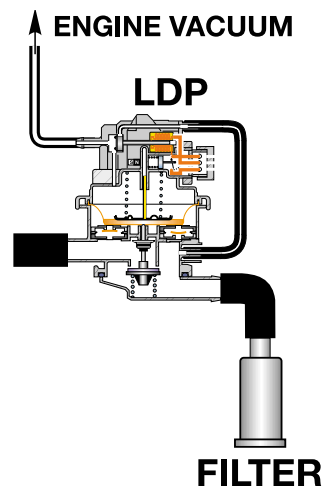

The ECM monitors the length of time it takes for the reed switch to open, which is opposed by pressure under the diaphragm in the lower chamber. If this component/circuits are defective, a fault code will be set and the "Malfunction Indicator Light" will illuminate when the OBD II criteria is achieved.

MS43 - Evaporative Leakage Detection (DM TL):

This component ensures accurate fuel system leak detection for leaks **as small as 0.5 mm** by slightly pressurizing the fuel tank and evaporative components. The DM TL pump contains an integral DC motor which is activated directly by the ECM. The ECM monitors the pump motor operating current as the measurement for detecting leaks.

The pump also contains an ECM controlled change over valve that is energized closed during a Leak Diagnosis test. The change over valve is open during all other periods of operation allowing the fuel system to “breathe” through the inlet filter. The DM TL is located under the luggage compartment floor with the Active Carbon Cannister (E46 for example).

1. In its inactive state, filtered fresh air enters the evaporative system through the sprung open valve of the DM TL.

2. When the DME activates the DM TL for leak testing, it first activates only the pump motor. This pumps air through a restrictor orifice (0.5 mm) which causes the electric motor to draw a specific amperage value. This value is equivalent to the size of the restrictor.

3. The solenoid valve is then energized which seals the evaporative system and directs the pump output to pressurize the evaporative system.

- A large leak is detected in the evaporative system if the amperage value is not achieved.
- A small leak is detected if the same reference amperage is achieved.
- The system is sealed if the amperage value is higher than the reference amperage.

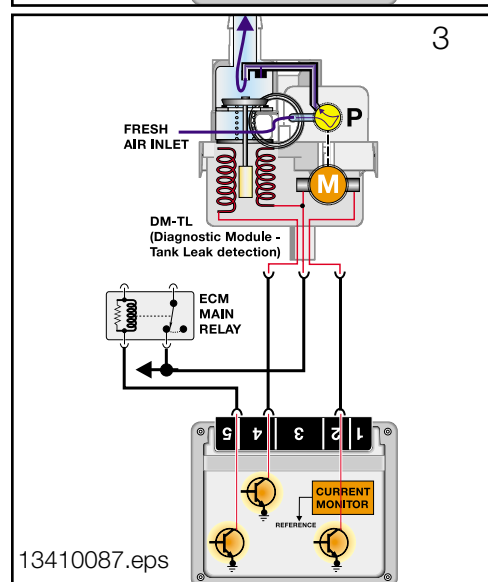
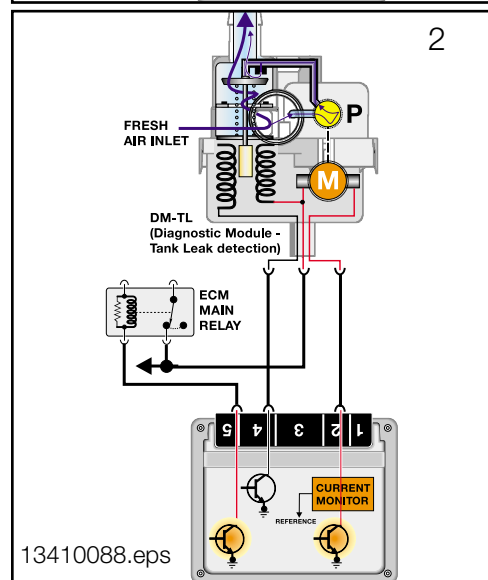
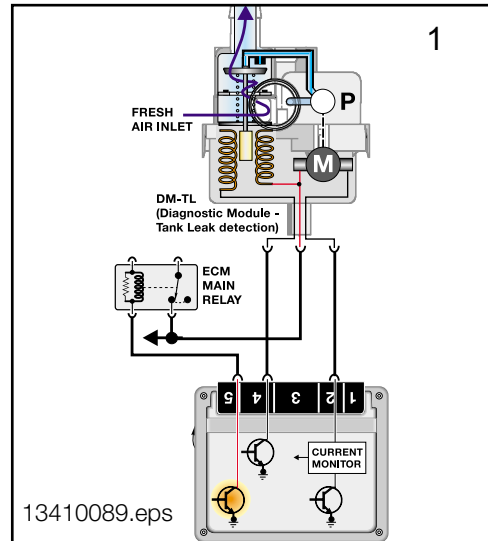

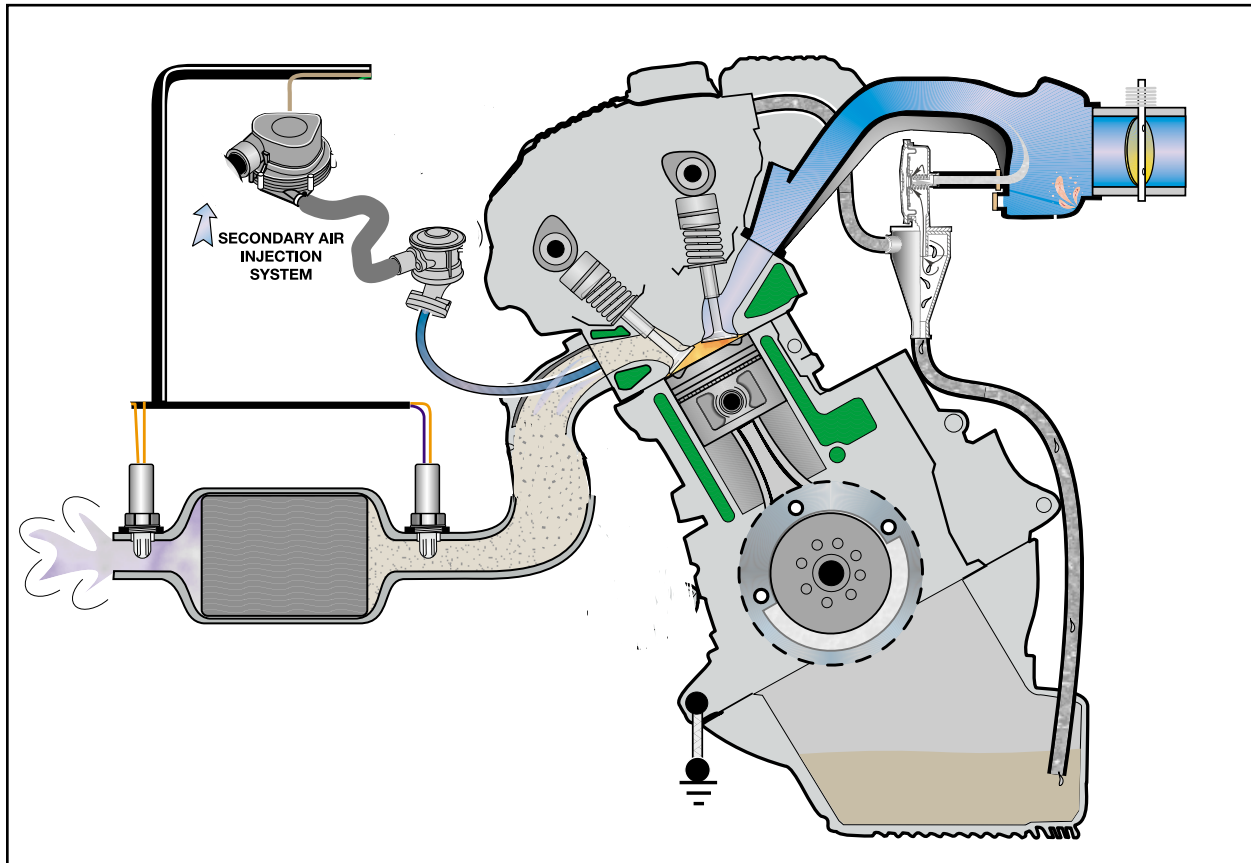

Exhaust Emissions: The combustion process of a gasoline powered engine produces Carbon Monoxide (CO), Hydrocarbons (HC) and Oxides of Nitrogen (NO_x).

- **Carbon Monoxide is a product of incomplete combustion under conditions of air deficiency. CO emissions are strongly dependent on the air/fuel ratio.**
- **Hydrocarbon are also a product of incomplete combustion which results in unburned fuel. HC emissions are dependent on air/fuel ratio and the ignition of the mixture.**
- **Oxides of Nitrogen are a product of peak combustion temperature (and temperature duration). NO_x emissions are dependent on internal cylinder temperature affected by the air/fuel ratio and ignition of the mixture.**

Control of exhaust emissions is accomplished by the engine and engine management design as well as after-treatment.

- **The ECM manages exhaust emissions by controlling the air/fuel ratio and ignition.**
- **The ECM controlled Secondary Air Injection further dilutes exhaust emissions leaving the engine and reduces the catalyst warm up time.**
- **The Catalytic Converter further reduces exhaust emissions leaving the engine.**

Bosch LSH 25 Oxygen Sensors: The pre-cat oxygen sensors measure the residual oxygen content of the exhaust gas. The sensors produce a low voltage (0-1000 mV) proportional to the oxygen content that allows the ECM to monitor the air/fuel ratio.

The sensors are mounted in the hot exhaust stream directly in front of the catalytic converters.

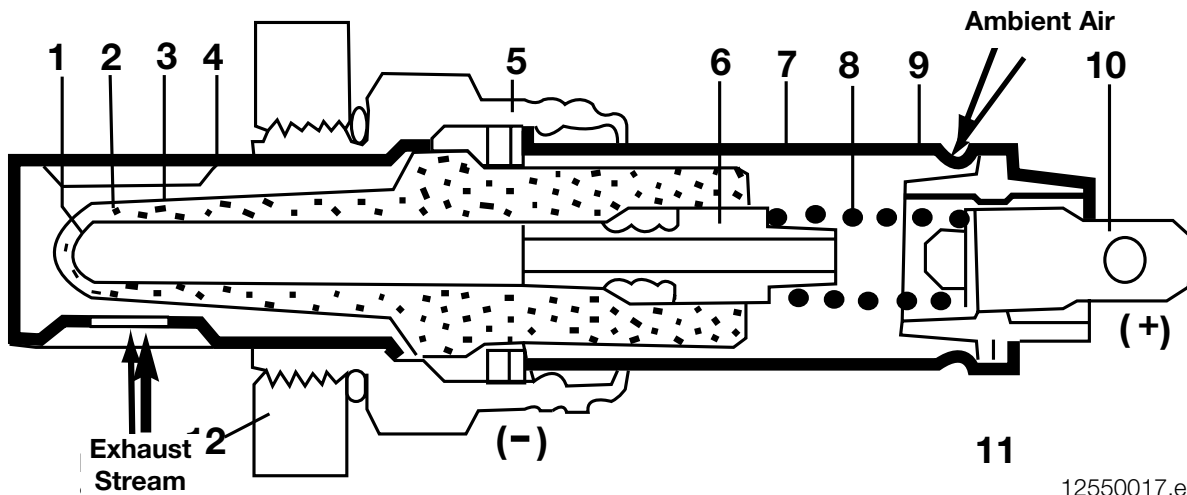
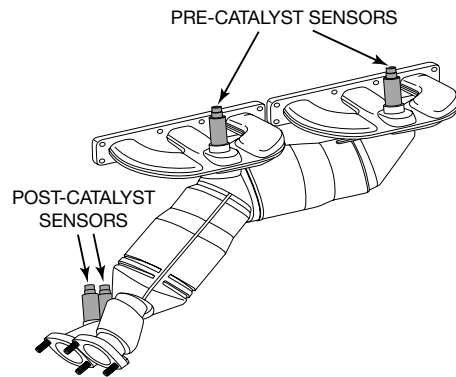

12550017.eps

1. Electrode (+)	7. External Body (Ventilated)
2. Electrode (-)	8. Contact Spring
3. Porous Ceramic Coating (encasing electrolyte)	9. Vent Opening
4. Protective Metal Cage (Ventilated)	10. Output Lead
5. Casing	11. Insulator
6. Contact Sleeve	12. Exhaust Pipe Wall

The “tip” of the sensor contains a microporous platinum coating (electrodes) which conduct current. The platinum electrodes are separated by solid electrolyte which conducts oxygen ions. The platinum conductors are covered with a highly porous ceramic coating and the entire tip is encased in a ventilated metal “cage”.

This assembly is submersed in the exhaust stream. The sensor body (external) has a small vent opening in the housing that allows ambient air to enter the inside of the tip.

The ambient air contains a constant level of oxygen content (21%) and the exhaust stream has a much lower oxygen content. The oxygen ions (which contain small electrical charges) are “purged” through the solid electrolyte by the hot exhaust gas flow. The electrical charges (low voltage) are conducted by the platinum electrodes to the sensor signal wire that is monitored by the ECM.

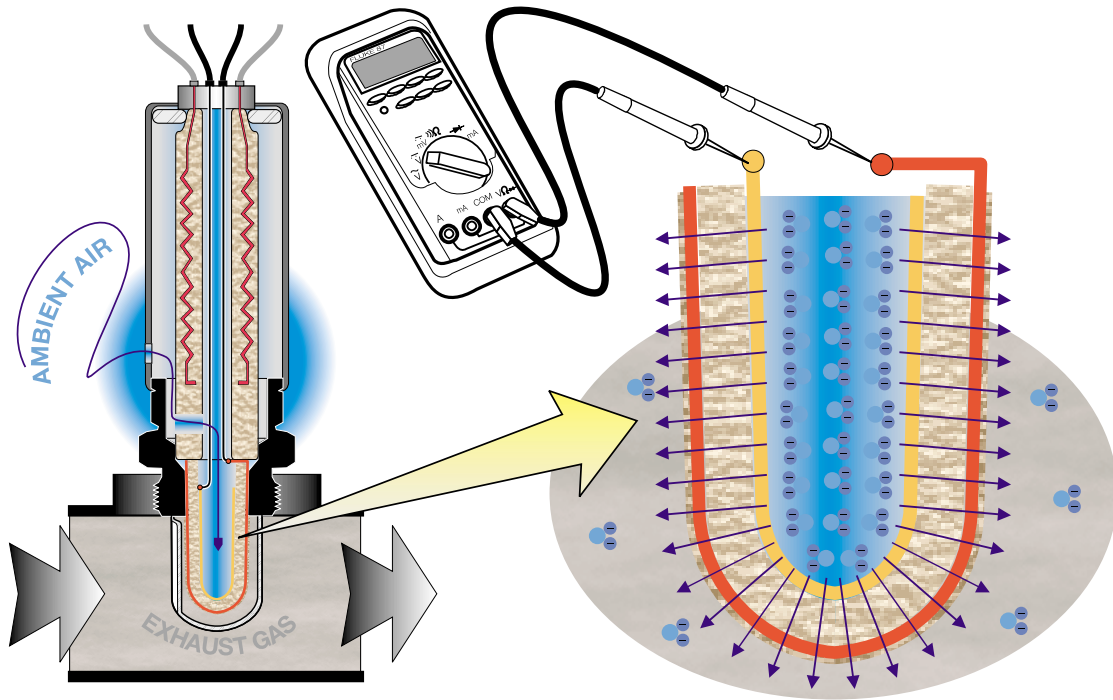

If the exhaust has a lower oxygen content (rich mixture), there will be a large ion “migration” through the sensor generating a higher voltage (950 mV).

If the exhaust has a higher oxygen content (lean mixture), there will be a small ion “migration” through the sensor generating a lower voltage (080 mV).

This voltage signal is constantly changing due to combustion variations and normal exhaust pulsations.

The ECM monitors the length of time the sensors are operating in the lean, rich (including the time of rise and fall) and rest conditions. The evaluation period of the sensors is over a predefined number of oscillation cycles.

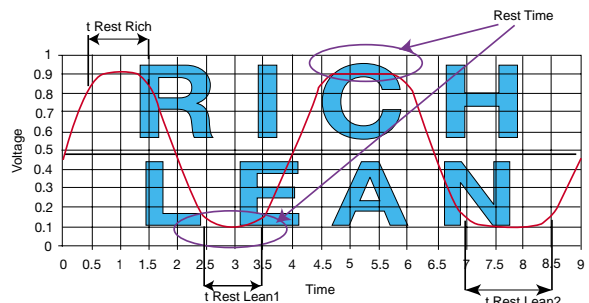

13550011.eps

This conductivity is efficient when the oxygen sensor is hot (250° - 300° C). For this reason, the sensor contains a heating element. This “heated” sensor reduces warm up time, and retains the heat during low engine speed when the exhaust temperature is cooler.

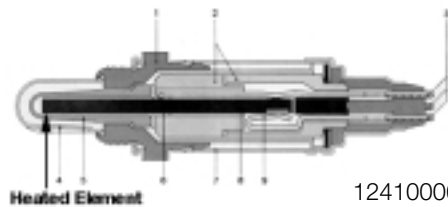

12410006.bmp

Direct Oxygen Sensor Heating: The oxygen sensor conductivity is efficient when it is hot (600° - 700° C). For this reason, the sensors contain heating elements. These “heated” sensors reduce warm up time, and retain the heat during low engine speed when the exhaust temperature is cooler. OBD II requires monitoring of the oxygen sensor heating function and heating elements for operation.

The four oxygen sensor heating circuits (E46/E39 shown) receive operating voltage from the ECM Relay when KL15 is switched “ON”. Each of the sensors heaters are controlled through separate final stage transistors.

The sensor heaters are controlled with a pulse width modulated voltage during a cold start. This allows the sensors to be brought up to operating temperature without the possibility of thermal shock. The duty cycle is then varied to maintain the heating of the sensors.

When the engine is decelerating (closed throttle), the ECM increases the duty cycle of the heating elements to compensate for the decreased exhaust temperature.

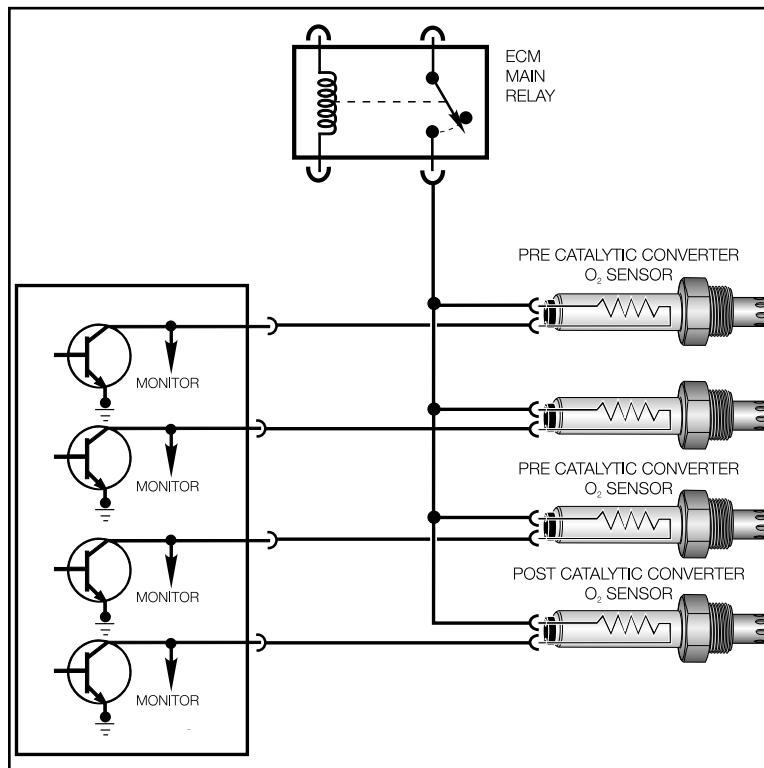

Catalytic Converter Monitoring: The efficiency of catalyst operation is determined by evaluating the oxygen consumption of the catalytic converters using the pre and post oxygen sensor signals. A properly operating catalyst consumes most of the O₂ (oxygen) that is present in the exhaust gas (input to catalyst). The gases that flow into the catalyst are converted from CO, HC and NO_x to CO₂, H₂O and N₂ respectively.

In order to determine if the catalysts are working correctly, post catalyst oxygen sensors are installed to monitor exhaust gas content exiting the catalysts. The signal of the post cat. O₂ sensor is evaluated over the course of several pre cat. O₂ sensor oscillations.

During the evaluation period, the signal of the post cat. sensor must remain within a relatively constant voltage range (700 - 800 mV). The post cat. O₂ voltage remains high with a very slight fluctuation. This indicates a further lack of oxygen when compared to the pre cat. sensor.

If this signal decreased in voltage and/or increased in fluctuation, a fault code will be set for Catalyst Efficiency and the “Malfunction Indicator Light” will illuminate when the OBD II criteria is achieved.

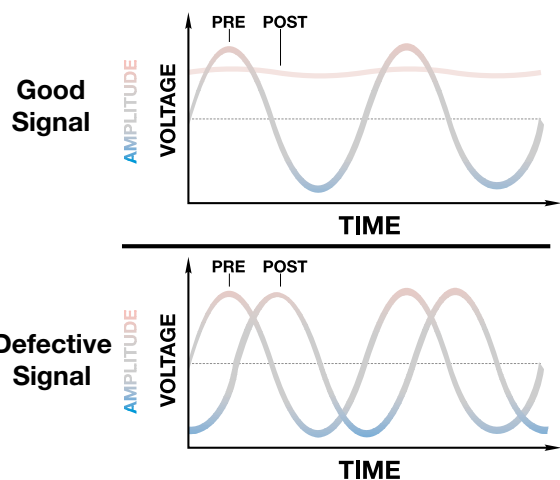

Secondary Air Injection: Injecting ambient air into the exhaust stream after a cold engine start reduces the warm up time of the catalyst and reduces HC and CO emissions. The ECM controls and monitors the Secondary Air Injection.

An Electric Air Pump and Air Injection Valve direct fresh air through an internal channel in the cylinder head into the exhaust ports. The Air Injection Valve is opened by air pressure (from the pump) and is closed by an internal spring.



The Air Injection Inlet Valve mounts directly to the cylinder head, with a passageway machined through the head. This eliminates the external Air Injection manifold distribution pipes to the exhaust manifolds.

Misfire Detection: As part of the OBD II regulations the ECM must determine misfire and also identify the specific cylinder(s), the severity of the misfire and whether it is emissions relevant or catalyst damaging based on monitoring crankshaft acceleration.

In order to accomplish these tasks the ECM monitors the crankshaft for acceleration by the impulse wheel segments of cylinder specific firing order. The misfire/engine roughness calculation is derived from the differences in the period duration of individual increment gear segments.

Each segment period consist of an angular range of 90° crank angle that starts 54° before Top Dead Center.

If the expected period duration is greater than the permissible value a misfire fault for the particular cylinder is stored in the fault memory of the ECM.

Depending on the level of misfire rate measured the ECM will illuminate the "Malfunction Indicator Light", deactivate the specific fuel injector to the particular cylinder and switch oxygen sensor control to open-loop.

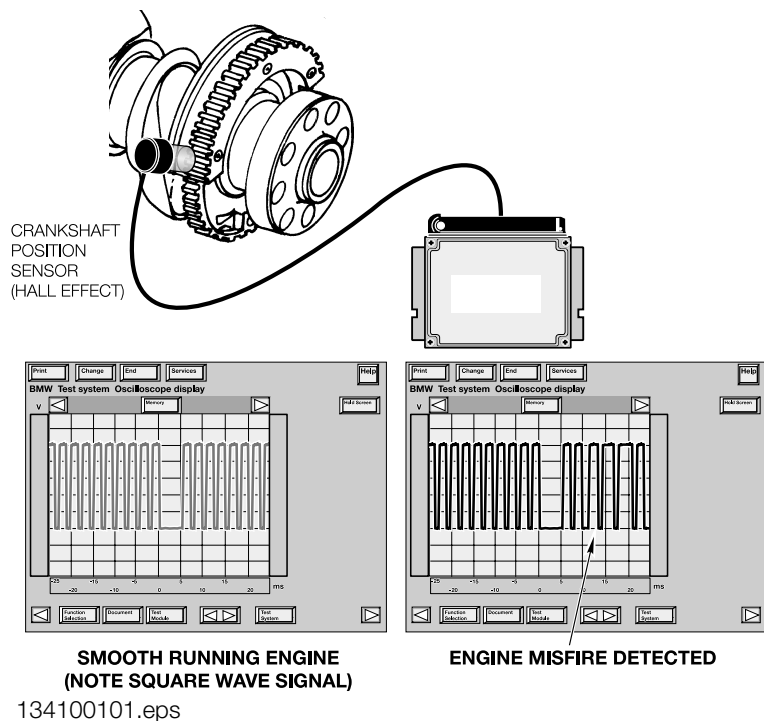

In order to eliminate misfire faults that can occur as a result of varying flywheel tolerances (manufacturing process) an internal adaptation of the flywheel is made. The adaptation is made during periods of decel fuel cut-off in order to avoid any rotational irregularities which the engine can cause during combustion. This adaptation is used to correct segment duration periods prior to evaluation for a misfire event.

If the sensor wheel adaptation has not been completed the misfire thresholds are limited to engine speed dependent values only and misfire detection is less sensitive. The crankshaft sensor adaptation is stored internally and is not displayed via DIS or MoDIC. If the adaptation limit is exceeded a fault will be set.

Principle of Operation

Emissions Management controls evaporative and exhaust emissions. The ECM monitors the fuel storage system for **evaporative leakage** and controls the **purging** of evaporative vapors. The ECM monitors and controls the exhaust emissions by regulating the **combustable mixture** and after treating by injecting **fresh air** into the exhaust system. The catalytic converter further breaks down remaining combustable exhaust gases and is monitored by the ECM for **catalyst efficiency**.

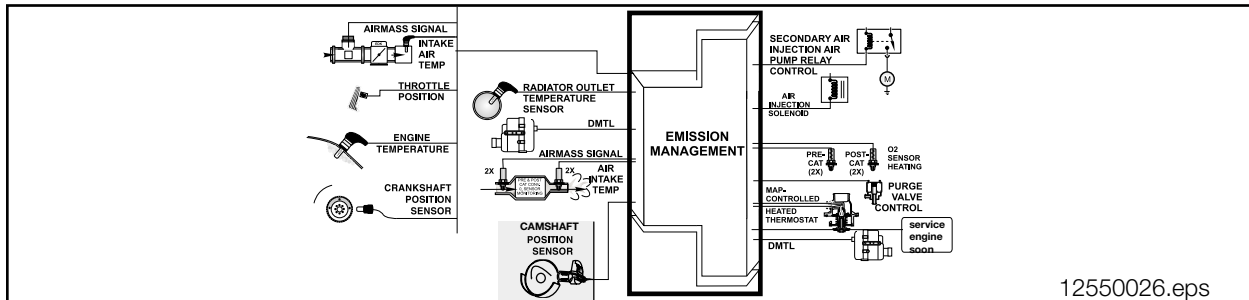

The MS42 Evaporative Leakage Detection uses a Leak Diagnosis Pump (LDP) to pressurize the fuel tank and the evaporative emission system (approx. 25mb.). The LDP equipped system is capable of detecting a leak as small as 0.5 mm. The LDP is replaceable as a complete component. The vacuum supply line (required for pump operation) is in the wiring harness from the engine compartment to the rear of the vehicle.

The LDP is a unitized component that contains the following:

- Vacuum Chamber
- Pneumatic Pressure Chamber
- DME Activated Vacuum Solenoid
- Reed Switch - providing a switched voltage feedback signal to the ECM

In the inactive state, the LDP diaphragm is at the bottom end (of down stroke). The diaphragm pushes a rod downward against spring pressure to open the canister vent valve.

This open valve serves as the filtered air inlet path for normal evaporative “breathing”.

During Leak Testing of the evaporative system, the vent valve is sprung closed to block atmospheric venting. The Evaporative Emission Valve is also sprung closed to seal the system.

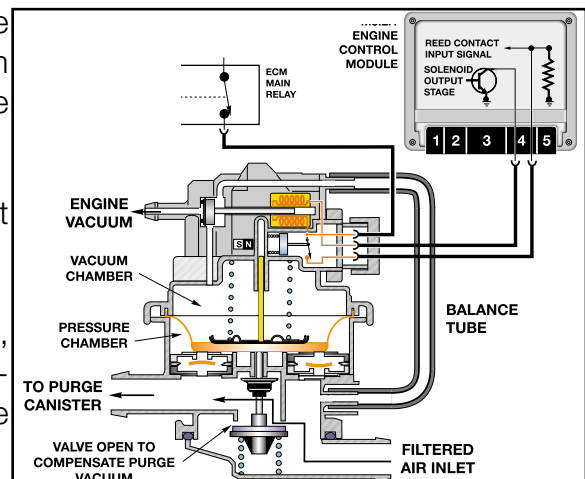

During every engine cold start the LDP solenoid is energized by the ECM. Engine manifold vacuum enters the upper chamber of the LDP to lift up the spring loaded diaphragm.

As the diaphragm is lifted it draws in ambient air through the filter and into the lower chamber of the LDP through the one way valve.

The solenoid is then de-energized, spring pressure closes the vacuum port blocking the engine vacuum and simultaneously opens the vent port to the balance tube which releases the captive vacuum in the upper chamber.

This allows the compressed spring to push the diaphragm down, starting the “limited down stroke”. The air that was drawn into the lower chamber of the LDP during the upstroke is forced out of the lower chamber and into the fuel tank/evaporative system.

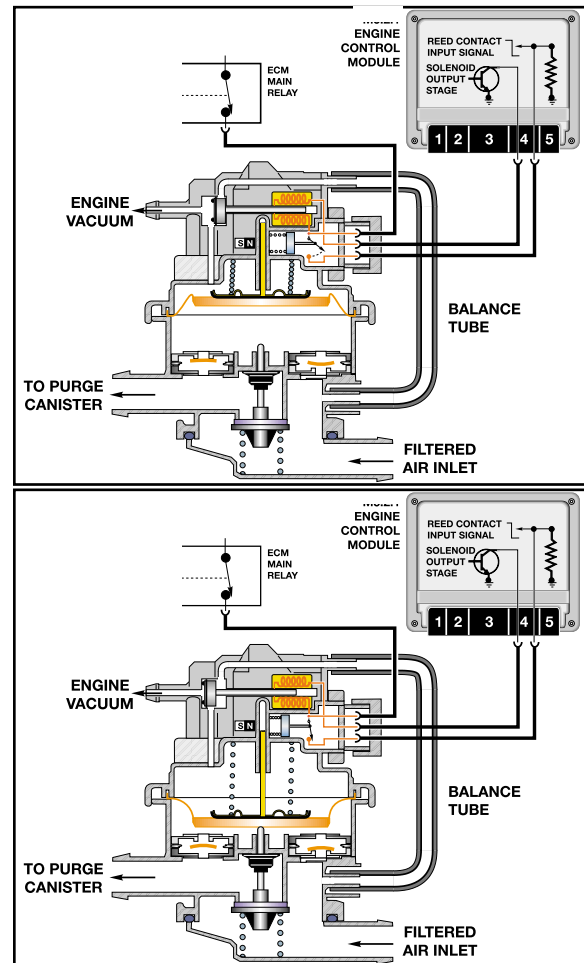

This electrically controlled repetitive up/down stroke is cycled repeatedly building up a total pressure of approximately +25mb in the evaporative system. After sufficient pressure has built up (LDP and its cycling is calibrated to the vehicle), the leak diagnosis begins and lasts about 100 seconds.

The upper chamber contains an integrated reed switch that produces a switched high/low voltage signal that is monitored by the ECM. The switch is opened by the magnetic interruption of the metal rod connected to the diaphragm when in the diaphragm is in the top dead center position.

The repetitive up/down stroke is confirmation to the ECM that the valve is functioning. The ECM also monitors the length of time it takes for the reed switch to open, which is opposed by pressure under the diaphragm in the lower chamber. The LDP is still cycled, but at a frequency that depends upon the rate of pressure loss in the lower chamber. If the pumping frequency is below parameters, there is no leak present. If the pumping frequency is above parameters, this indicates sufficient pressure can not build up in the lower chamber and evaporative system, indicating a leak.

The chart represents the diagnostic leak testing time frame in seconds. When the ignition is switched on, the ECM performs a “static check” of circuit integrity to the LDP pump including the reed switch.

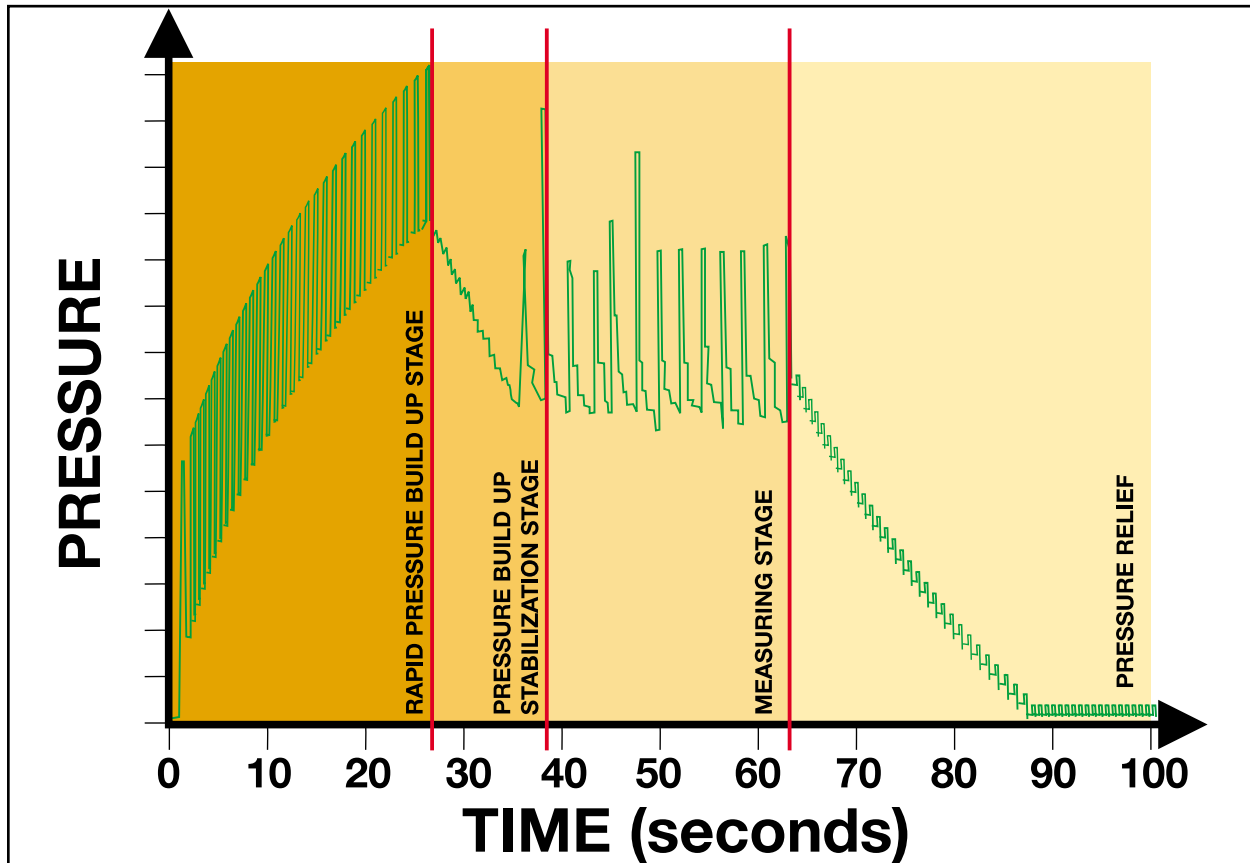

- On cold engine start up, the pump is rapidly activated for the first 27 seconds. This rapid pumping phase is required to pressurize the evaporative components.
- Once pressurized, the build up phase then continues from 27-38 seconds. The ECM monitors the system through the reed switch to verify that pressure has stabilized.
- The measuring phase for leak diagnosis lasts from 38-63 seconds. The pump is activated but due to the pressure build up under the diaphragm, the pump moves slower. If the pump moves quickly, this indicates a lack of pressure or a leak. This registers as a fault in the ECM's.
- From 63-100 seconds the pump is deactivated, allowing full down stroke of the diaphragm and rod. At the extreme bottom of rod travel, the canister vent valve is pushed open relieving pressure and allowing normal purge operation when needed.

The MS43 Evaporative Leakage Detection is performed on the fuel storage system by the DM TL pump which contains an integral DC motor that is activated by the ECM. The ECM monitors the pump motor operating current as the measurement for detecting leaks. The pump also contains an ECM controlled change over valve that is energized closed during a Leak Diagnosis test. The ECM only initiates a leak diagnosis test every second time the criteria are met. The criteria is as follows:

- Engine **OFF** with ignition switched **OFF**.
- ECM still in active state or what is known as “follow up mode” (ECM Relay energized, ECM and components online for extended period after key off).
- Prior to Engine/Ignition switch OFF condition, vehicle must have been driven for a minimum of 20 minutes.
- Prior to minimum 20 minute drive, the vehicle must have been OFF for a minimum of 5 hours.
- Fuel Tank Capacity must be between **15 and 85%** (safe approximation between 1/4 - 3/4 of a tank).
- Ambient Air Temperature between **-7°C & 35°C** (20°F & 95°F)
- Altitude **< 2500m** (8,202 feet).
- Battery Voltage - **11 Volts (minimum)**

When these criteria are satisfied every second time, the ECM will start the Fuel System Leak Diagnosis Test. The test will typically be carried out once a day ie., once after driving to work in the morning, when driving home in the evening, the criteria are once again met but the test is not initiated. The following morning, the test will run again.

PHASE 1 - Reference Measurement

The ECM activates the pump motor. The pump pulls air from the filtered air inlet and passes it through a precise 1.0 mm reference orifice in the pump assembly.

The ECM simultaneously monitors the pump motor current flow. The motor current rises quickly and levels off (stabilizes) due to the orifice restriction. The ECM stores the stabilized amperage value in memory. The stored amperage value is the electrical equivalent of a 1.0 mm (0.040”) leak.

PHASE 2 - Leak Detection

The ECM energizes the Change Over Valve allowing the pressurized air to enter the fuel system through the Charcoal Canister. The ECM monitors the current flow and compares it with the stored reference measurement over a duration of time.

Once the test is concluded, the ECM stops the pump motor and immediately de-energizes the change over valve. This allows the stored pressure to vent through the charcoal canister trapping hydrocarbon vapor and venting air to atmosphere through the filter.

Test Results

The time duration varies between 45 & 270 seconds depending on the resulting leak diagnosis test results (developed tank pressure “amperage” / within a specific time period). However the chart below depicts the logic used to determine fuel system leaks.

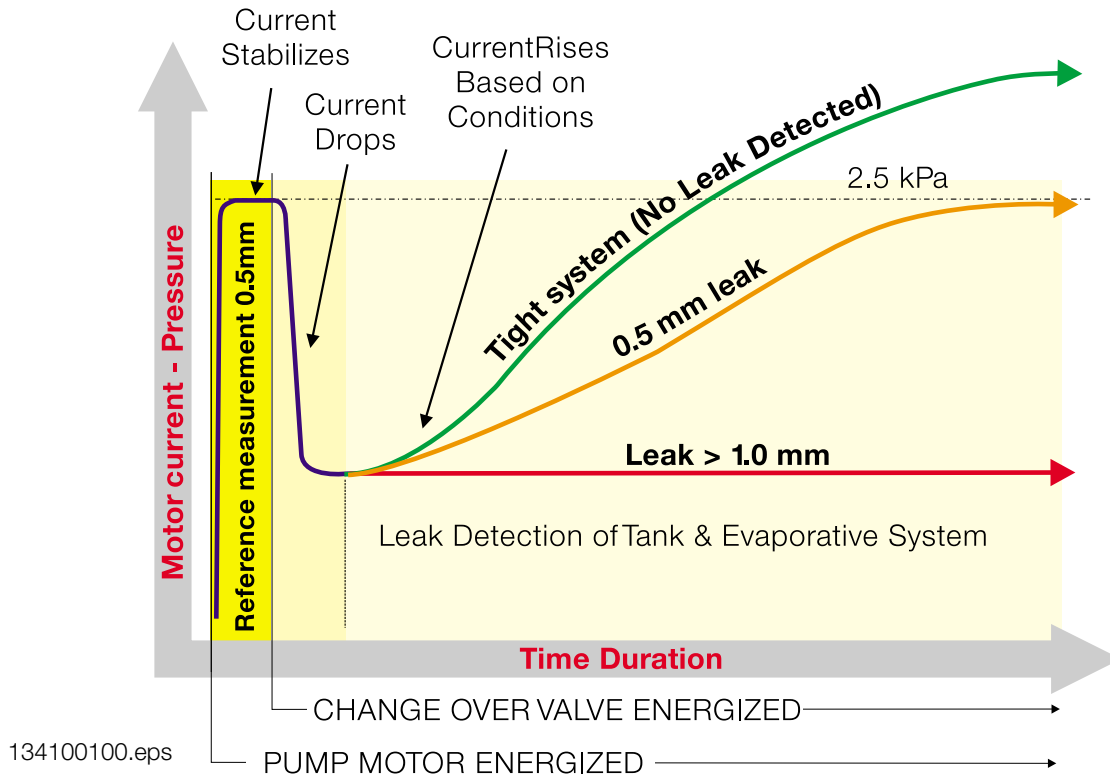

If the ECM detects a leak, a fault will be stored and the “Malfunction Indicator Light” will be illuminated. Depending on the amperage measurement detected by the ECM, the fault code displayed will be “small leak” or “large leak”.

Evaporative Emission Purging is regulated by the ECM controlling the Evaporative Emission Valve. The Evaporative Emission Valve is a solenoid that regulates purge flow from the Active Carbon Canister into the intake manifold. The ECM Relay provides operating voltage, and the ECM controls the valve by regulating the ground circuit. The valve is powered open and closed by an internal spring.

The “purging” process takes place when:

- Oxygen Sensor Control is active
- Engine Coolant Temperature is $>67^{\circ}\text{C}$
- Engine Load is present

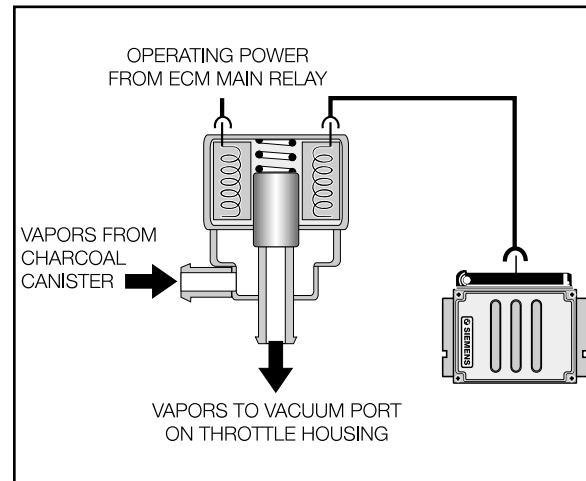

The Evaporative Emission Valve is opened in stages to moderate the purging.

- Stage 1 opens the valve for 10 ms (milli-seconds) and then closes for 150 ms.
- The stages continue with increasing opening times (up to 16 stages) until the valve is completely open.
- The valve now starts to close in 16 stages in reverse order
- This staged process takes 6 minutes to complete. The function is inactive for 1 minute then starts the process all over again.
- During the purging process the valve is completely opened during full throttle operation and is completely closed during deceleration fuel cutoff.

Evaporative Purge System Flow Check is performed by the ECM when the oxygen sensor control and purging is active. When the Evaporative Emission Valve is open the ECM detects a rich/lean shift as monitored by the oxygen sensors indicating the valve is functioning properly.

If the ECM does not detect a rich/lean shift, a second step is performed when the vehicle is stationary and the engine is at idle speed. The ECM opens and close the valve (abruptly) several times and monitors the engine rpm for changes. If there are no changes, a fault code will be set.

Fuel System Monitoring is performed by the ECM which verifies the calculated injection time (t_i) in relation to engine speed, load and the oxygen sensor signal as a result of the residual oxygen in the exhaust stream.

The ECM uses the oxygen sensor signal as a correction factor for adjusting and optimizing the mixture pilot control under all engine operating conditions.

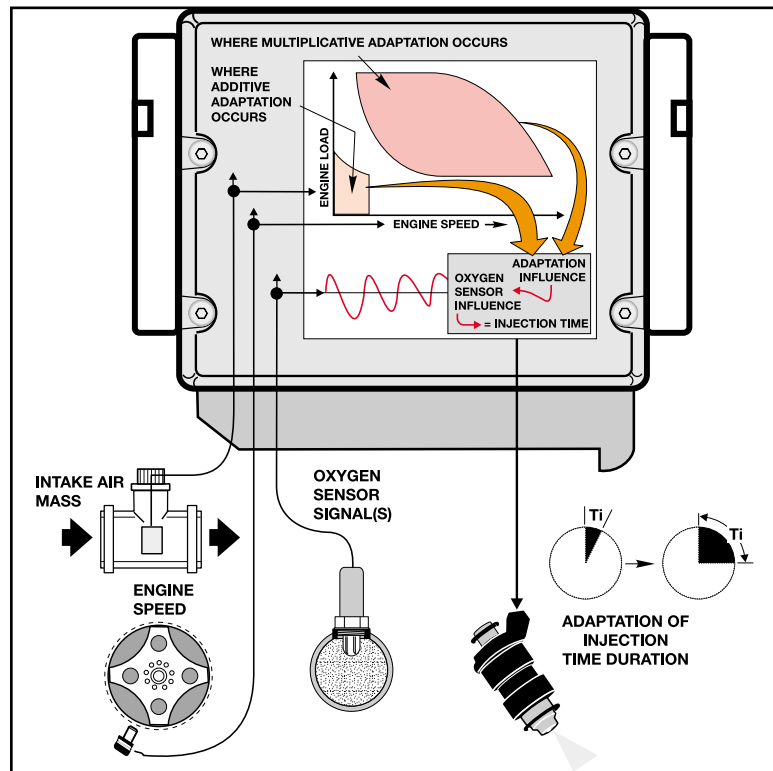

Adaptation Values are stored by the ECM in order to maintain an "ideal" air/fuel ratio. The ECM is capable of adapting to various environmental conditions encountered while the vehicle is in operation (changes in altitude, humidity, ambient temperature, fuel quality, etc.).

The adaptation can only make slight corrections and can not compensate for large changes which may be encountered as a result of incorrect airflow or incorrect fuel supply to the engine.

Within the areas of adjustable adaption, the ECM modifies the injection rate under two areas of engine operation:

- **During idle and low load mid range engine speeds (Additive Adaptation).**
- **During operation under a normal to higher load when at higher engine speeds (Multiplicative Adaptation).**

These values indicate how the ECM is compensating for a less than ideal initial air/fuel ratio.

NOTE: If the adaptation value is greater than "0.0" Additive (% Multiplicative), the ECM is trying to richen the mixture. If the adaptation value is less then "0.0" Additive (% Multiplicative), the ECM is trying to lean-out the mixture.

Catalyst Monitoring is performed by the ECM under oxygen sensor closed loop operation. The changing air/fuel ratio in the exhaust gas results in lambda oscillations at the pre-catalyst sensors. These oscillations are dampened by the oxygen storage activity of the catalysts and are reflected at the post catalyst sensors as a fairly stable signal (indicating oxygen has been consumed). Conditions for Catalyst Monitoring:

Requirements

- Closed loop operation
- Engine coolant temperature
- Vehicle road speed
- Catalyst temperature (calculated)*
- Throttle angle deviation
- Engine speed deviation
- Average lambda value deviation

Status/Condition

YES
 Operating Temp.
 3 - 50 MPH (5 to 80 km/h)
 350°C to 650°C
 Steady throttle
 Steady/stable engine speed
 Steady/stable load

* Catalyst temperature is an internally calculated value that is a function of load/air mass and time.

As part of the monitoring process, the pre and post O₂ sensor signals are evaluated by the ECM to determine the length of time each sensor is operating in the rich and lean range.

If the catalyst is defective the post O₂ sensor signal will reflect the pre O₂ sensor signal (minus a phase shift/time delay), since the catalyst is no longer able to store oxygen.

The catalyst monitoring process is stopped once the predetermined number of cycles are completed, until the engine is shut-off and started again. After completing the next "customer driving cycle" whereby the specific conditions are met and a fault is again set, the "Malfunction Indicator Light" will be illuminated.

Note: The catalyst efficiency is monitored once per trip while the vehicle is in closed loop operation.

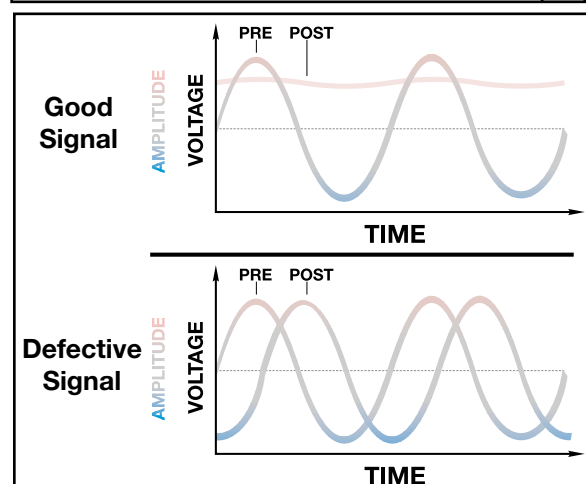
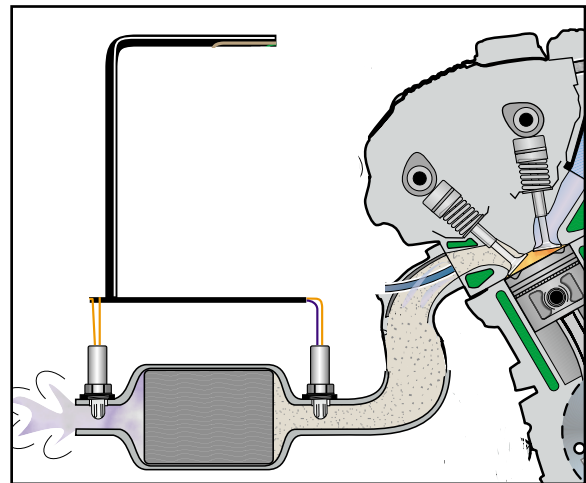

Misfire Detection is part of the OBD II regulations the ECM must determine misfire and also identify the specific cylinder(s). The ECM must also determine the severity of the misfire and whether it is emissions relevant or catalyst damaging based on monitoring crankshaft acceleration.

Emission Increase:

- Within an interval of 1000 crankshaft revolutions, the ECM adds the the detected misfire events for each cylinder. If the sum of all cylinder misfire incidents exceeds the predetermined value, a fault code will be stored and the “Malfunction Indicator Light” will be illuminated.
- If more than one cylinder is misfiring, all misfiring cylinders will be specified and the individual fault codes for each misfiring cylinder, or multiple cylinders will be stored. The “Malfunction Indicator Light” will be illuminated.

Catalyst Damage:

- Within an interval of 200 crankshaft revolutions the detected number of misfiring events is caluated for each cylinder. The ECM monitors this based on load/rpm. If the sum of cylinder misfire incidents exceeds a predetermined value, a “Catalyst Damaging” fault code is stored and the “Malfunction Indicator Light” will be illuminated.

If the cylinder misfire count exceeds the predetermined threshold the ECM will take the following measures:

- The oxygen sensor control will be switched to open loop.
- The cylinder selective fault code is stored.
- If more than one cylinder is mis firing the fault code for all individual cylinders and for multiple cylinders will be stored.
- The fuel injector to the respective cylinder(s) is deactivated.

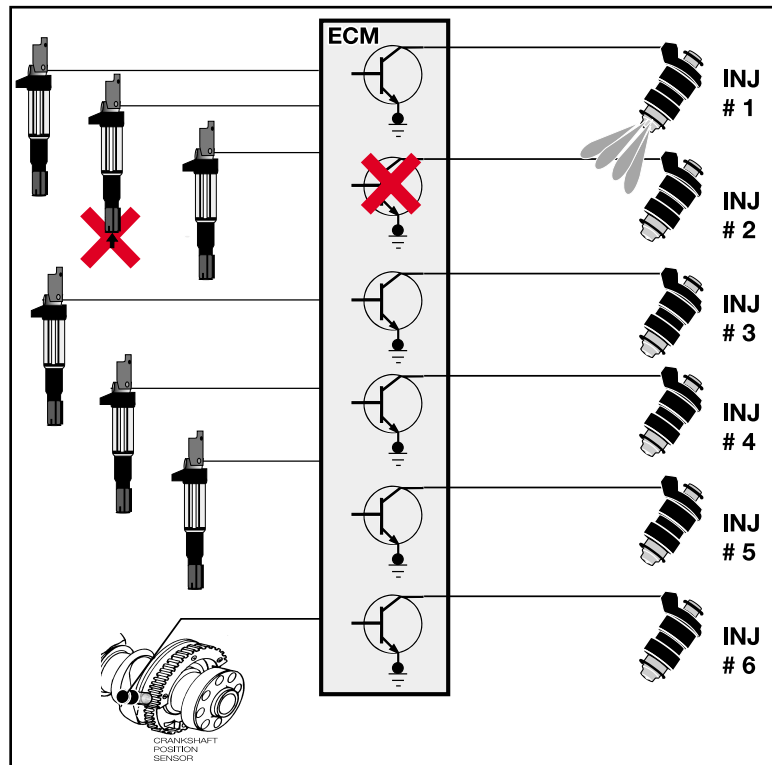

Electrically Heated Thermostat

Model specific variants of the electrically heated thermostat are now equipped on all LEV/ULEV compliant engines. This thermostat allows the engine to run hotter than conventional thermostats improving fuel economy.

The ECM also electrically activates the thermostat to lower the engine coolant temperatures based on monitored conditions. It is both a conventionally functioning and ECM controlled thermostat (two stage operation). ECM control adds heat to the wax core causing the thermostat to open earlier than it's mechanical temperature rating providing increased coolant flow.

Conventional Function: The thermostat begins to open at 103°C. This is at the inlet side of the water pump and represents the temperature of the coolant entering the engine. Before the 103°C temperature is realized, the coolant is circulated through the engine block by the water pump.

After the temperature reaches 103°C it is maintained as the inlet temperature by the thermostat. The coolant temperature at the water pump engine outlet is approximately 110°C. The additional 7°C is achieved after the coolant has circulated through the block.

The operating temperature of the engine will remain within this range as long as the engine is running at part load conditions and the engine coolant temperature does not exceed 113°C.

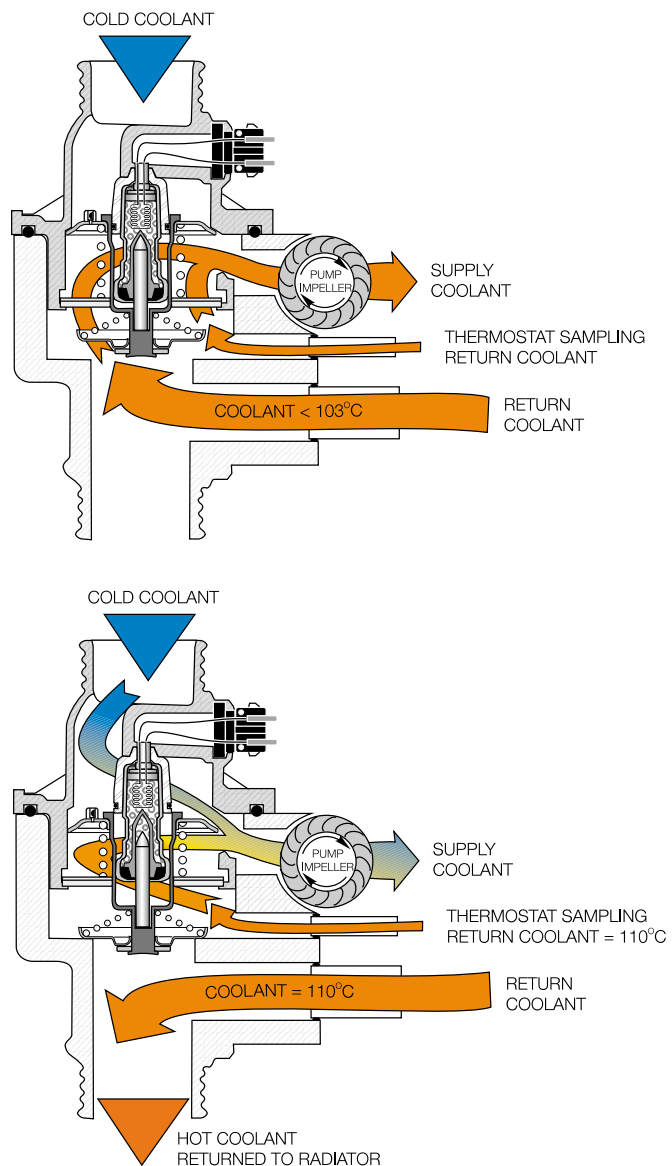
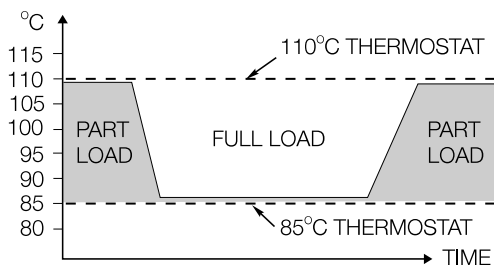

ECM Control

Electric thermostat activation is based on the following parameters:

- Engine temperature > 113°C
- Radiator Coolant Outlet Temperature
- Load signal “ti” > 5.8 ms
- Intake air temp > 52°C
- Vehicle speed > 110 MPH

When one or more of these monitored conditions is determined, the ECM activates (switched ground) the thermostat circuit. The activated heating element causes the wax core in the thermostat to heat up and open the thermostat increasing coolant circulation through the radiator which brings the engine temperature down.

The temperature of the coolant at the inlet side of the water pump will drop to approximately 85°C and the temperature at the outlet side will drop to approximately 103°C when activated.

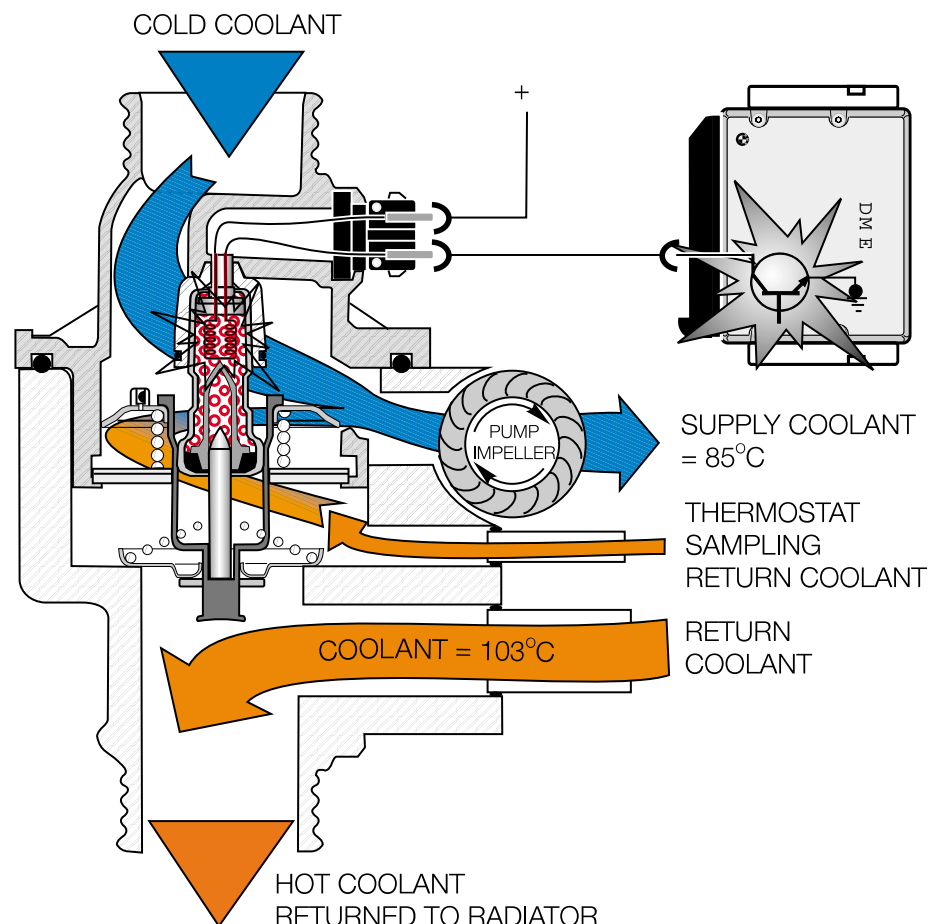

The “**Malfunction Indicator Light**” (MIL) will be illuminated under the following conditions:

- Upon the completion of the **next consecutive driving cycle** where the previously faulted system is monitored again and the emissions relevant fault is again present.
- Immediately if a “Catalyst Damaging” fault occurs (see Misfire Detection).

The illumination of the light is performed in accordance with the Federal Test Procedure (FTP) which requires the lamp to be illuminated when:

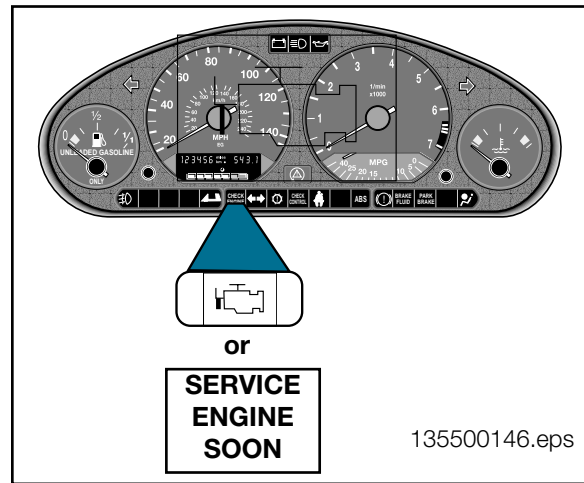

- A malfunction of a component that can affect the emission performance of the vehicle occurs and causes emissions to exceed 1.5 times the standards required by the (FTP).
- Manufacturer-defined specifications are exceeded.
- An implausible input signal is generated.
- Catalyst deterioration causes HC-emissions to exceed a limit equivalent to 1.5 times the standard (FTP).
- Misfire faults occur.
- A leak is detected in the evaporative system, or “purging” is defective.
- ECM fails to enter closed-loop oxygen sensor control operation within a specified time interval.
- Engine control or automatic transmission control enters a "limp home" operating mode.
- Ignition is on (KL15) position before cranking = **Bulb Check Function**.

Within the BMW system the illumination of the Malfunction Indicator Light is performed in accordance with the regulations set forth in CARB mail-out 1968.1 and as demonstrated via the Federal Test Procedure (FTP). The following page provides several examples of when and how the Malfunction Indicator Light is illuminated based on the "customer drive cycle".

TEXT NO.	DRIVE CYCLE # 1			DRIVE CYCLE # 2			DRIVE CYCLE # 3			DRIVE CYCLE # 4			DRIVE CYCLE # 5			* DRIVE CYCLE # 43					
	FUNCTION CHECKED	FAULT CODE SET	MIL STATUS CHECK ENGINE	FUNCTION CHECKED	FAULT CODE SET	MIL STATUS CHECK ENGINE	FUNCTION CHECKED	FAULT CODE SET	MIL STATUS CHECK ENGINE	FUNCTION CHECKED	FAULT CODE SET	MIL STATUS CHECK ENGINE	FUNCTION CHECKED	FAULT CODE SET	MIL STATUS CHECK ENGINE	FUNCTION CHECKED	FAULT CODE SET	MIL STATUS CHECK ENGINE	FUNCTION CHECKED	FAULT CODE SET	MIL STATUS CHECK ENGINE
1.	YES	YES	OFF																		
2.	YES	YES	OFF	YES	YES	ON															
3.	YES	YES	OFF	NO	NO	OFF	YES	YES	ON												
4.	YES	YES	OFF	YES	NO	OFF	YES	NO	OFF	YES	YES	OFF	YES	YES	ON						
5.	YES	YES	OFF	YES	YES	ON	YES	NO	ON	YES	NO	ON	YES	NO	OFF						
6.	YES	YES	OFF	YES	YES	ON	YES	NO	ON	YES	NO	ON	YES	NO	OFF	YES	NO	OFF	YES	NO	OFF
																			FUNCTION CHECKED	FAULT CODE ERASED	MIL STATUS CHECK ENGINE

1. A fault code is stored within the ECM upon the first occurrence of a fault in the system being checked.
2. The "Malfunction Indicator Light" will not be illuminated until the completion of the second consecutive "customer driving cycle" where the previously faulted system is again monitored and a fault is still present or a catalyst damaging fault has occurred.
3. If the second drive cycle was not complete and the specific function was not checked as shown in the example, the ECM counts the third drive cycle as the "next consecutive" drive cycle. The "Malfunction Indicator Light" is illuminated if the function is checked and the fault is still present.
4. If there is an intermittent fault present and does not cause a fault to be set through multiple drive cycles, two complete consecutive drive cycles with the fault present are required for the "Malfunction Indicator Light" to be illuminated.
5. Once the "Malfunction Indicator Light" is illuminated it will remain illuminated unless the specific function has been checked without fault through three complete consecutive drive cycles.
6. The fault code will also be cleared from memory automatically if the specific function is checked through 40 consecutive drive cycles without the fault being detected or with the use of either the DIS, MODIC or Scan tool.

NOTE: In order to clear a catalyst damaging fault (see Misfire Detection) from memory, the condition must be evaluated for 80 consecutive cycles without the fault reoccurring.

With the use of a universal scan tool, connected to the "OBD" DLC an SAE standardized DTC can be obtained, along with the condition associated with the illumination of the "Malfunction Indicator Light". Using the DIS or MODIC, a fault code and the conditions associated with its setting can be obtained prior to the illumination of the "Malfunction Indicator Light".

OBD II Drive Cycle's & Trips

- A "**Drive cycle**" consists of engine startup and engine shutoff.
- "**Trip**" is defined as vehicle operation (following an engine-off period) of duration and driving style so that all components and systems are monitored at least once by the diagnostic system except catalyst efficiency or evaporative system monitoring.

This definition is subject to the limitations that the manufacturer-defined trip monitoring conditions are all monitored at least once during the first engine start portion of the Federal Test Procedure (FTP).

- Within this text the term "**customer driving cycle**" will be used and is defined as engine start-up, operation of vehicle (dependent upon customer drive style) and engine shut-off.

Federal Test Procedure (FTP)

The Federal Test Procedure (FTP) is a **specific driving cycle** that is utilized by the EPA to test light duty vehicle emissions. As part of the procedure for a vehicle manufacturer to obtain emission certification for a particular model/engine family the manufacturer must demonstrate that the vehicle(s) can pass the FTP defined driving cycle **two consecutive times** while monitoring various components/systems.

Some of the components/systems must be monitored ***either once per driving cycle or continuously***. Systems and their components required to be monitored **once within one driving cycle**:

- Oxygen Sensors
- Secondary Air Injection System
- Catalyst Efficiency
- Evaporative Vapor Recovery System

Due to the complexity involved in meeting the test criteria within the FTP defined driving cycle, all tests may not be completed within one "customer driving cycle". The test can be successfully completed within the FTP defined criteria, however customer driving styles may differ and therefore may not always monitor all involved components/systems in one "trip".

Components/systems required to be monitored continuously:

- Cylinder Misfire Detection
- Fuel system
- Oxygen Sensors
- All emissions related components/systems - ECM, EGS or EML (comprehensive component monitoring).

The graph shown below is an example of the driving cycle that is used by BMW to complete the FTP.

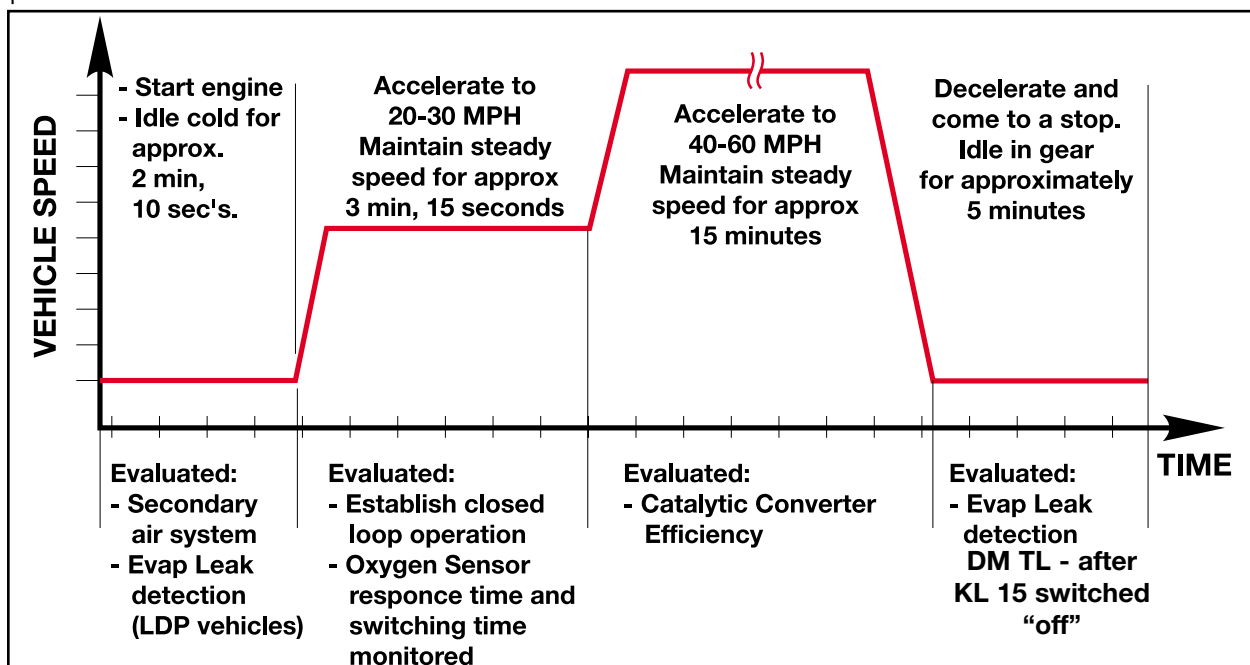

The diagnostic routine shown above will be discontinued whenever:

- Engine speed exceeds 3000 RPM
- Large fluctuations in throttle angle
- Road speed exceeds 60 MPH

NOTE: The driving criteria shown can be completed within the FTP required ~11 miles in a controlled environment such as a dyno test or test track.

A "customer driving cycle" may vary according to traffic patterns, route selection and distance traveled, which may not allow the "diagnostic trip" to be fully completed each time the vehicle is operated.

Readiness Code

The readiness code provides status (Yes/No) of the system having completed all the required monitoring functions or not. The readiness code is displayed with an aftermarket scan tool. The code is a binary (1/0) indicating;

- 0 = Test Completed or Not Applicable
- 1 = Test Not Completed

A "readiness code" must be stored after any clearing of fault memory or disconnection of the ECM. A readiness code of "0" will be stored (see below) after a complete diagnostic check of all components/systems, that can turn on the "Malfunction Indicator Light" is performed.

The readiness code was established to prevent anyone with an emissions related fault and a "Malfunction Indicator Light" on from disconnecting the battery or clearing the fault memory to manipulate the results of the emissions test procedure (IM 240).

Interpretation of the Readiness Code by the ECM(s) (SAE J1979)

The complete readiness code is equal to "one" byte (eight bits). Every bit represents one complete test and is displayed by the scan tool, as required by CARB/EPA.

1 = EGR Monitoring (=0, N/A with BMW)

0 = Oxygen Sensor Heater Monitoring

1 = Oxygen Sensor Monitoring

1 = Air Condition (=0, N/A with BMW)

0 = Secondary Air Delivery Monitoring

1 = Evaporative System Monitoring

1= Catalyst Heating (=0, N/A with BMW at this time)

0 = Catalyst Efficiency Monitoring

Drive the car in such a manner that all tests listed above can be completed (refer to the FTP cycle). When the complete "readiness code" equals "0" then all tests have been completed and the system has established its "readiness". Accessibility of the readiness code is also possible using the DIS/MoDIC.

OBD II Diagnostic Trouble Codes (DTC)

The Society of Automotive Engineers (SAE) established the Diagnostic Trouble Codes used for OBD II systems (SAE J2012). The DTC's are designed to be identified by their alpha/numeric structure. The SAE has designated the emission related DTC's to start with the letter "P" for Powertrain related systems, hence their *nickname* "P-code".

For example:

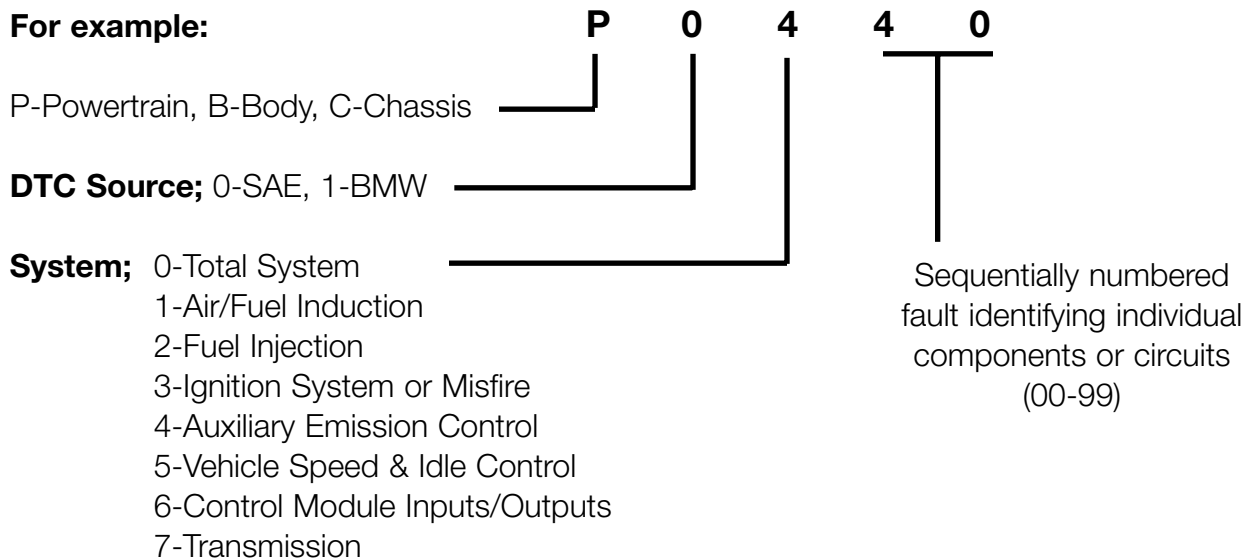

- DTC's are stored whenever the "Malfunction Indicator Light" is illuminated.
- A requirement of CARB/EPA is providing universal diagnostic access to DTC's via a standardized Diagnostic Link Connector (DLC) using a standardized tester (scan tool).
- DTC's only provide one set of environmental operating conditions when a fault is stored. This single "Freeze Frame" or snapshot refers to a block of the vehicles environmental conditions for a specific time when the fault first occurred. The information which is stored is defined by SAE and is limited in scope. This information may not even be specific to the type of fault.

Scan Tool Connection

The MS42/MS43 has a separate OBD II Diagnostic Link Connector (DLC). The OBD II connector is located in the drivers footwell to the left of the steering column (right side of center console on the Z3). The DLC provides access for an aftermarket scan tool to all emission related control systems:

- ECM - Engine Management Monitored Emissions Functions/Components
- TCM (AGS/EGS) - Transmission Control
- EML - Electronic Throttle Control

This diagnostic communication link uses the existing TXD II circuit in the vehicle through a separate circuit on the DLC when the 20 pin cap is installed.

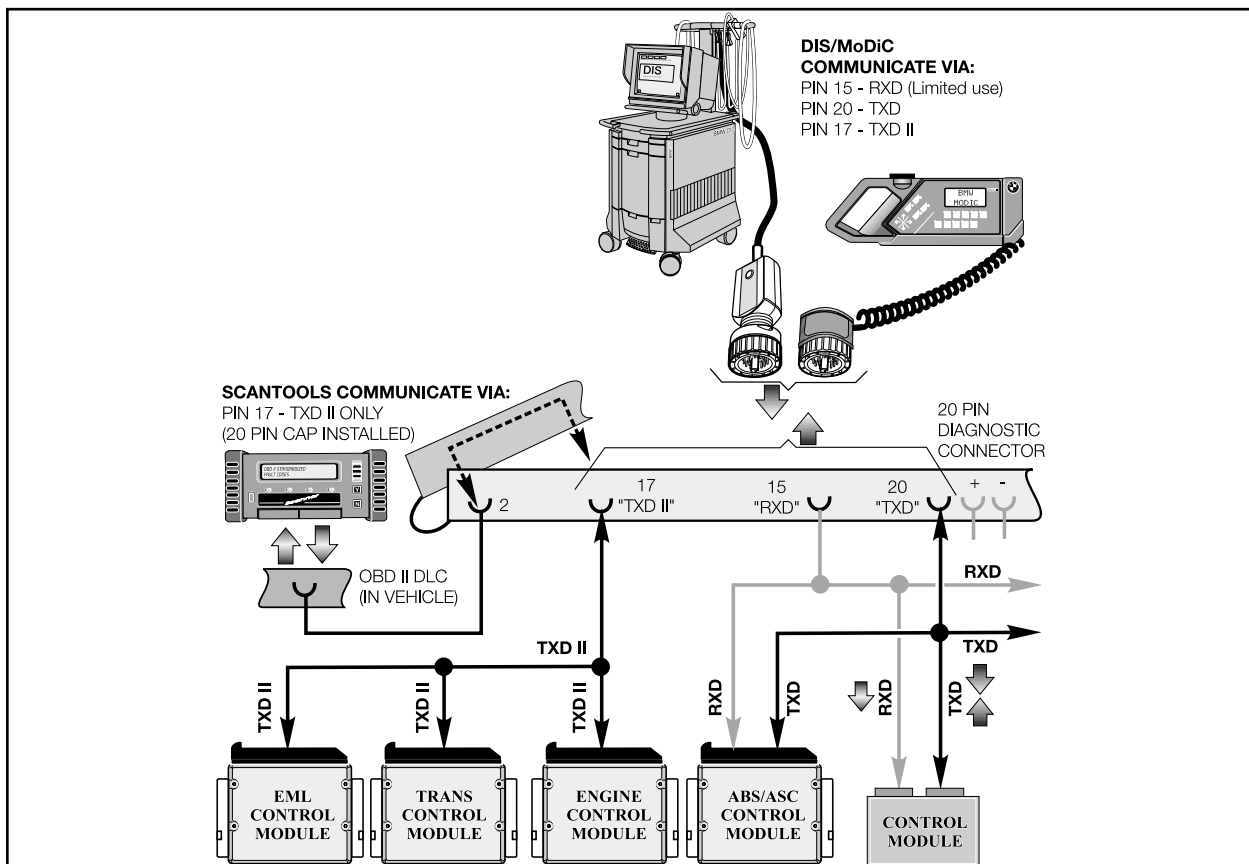

BMW Fault Code (DIS/MoDiC)

- BMW Codes are stored as soon they occur even before the "Malfunction Indicator Light" comes on.
- BMW Codes are defined by BMW and Siemens Engineers to provide greater detail to fault specific information.
- Siemens systems - one set of four fault specific environmental conditions are stored with the first fault occurrence. This information can change and is specific to each fault code to aid in diagnosing. A maximum of ten different faults containing four environmental conditions can be stored.
- BMW Codes also store and displays a "time stamp" when the fault last occurred.
- A fault qualifier gives more specific detailed information about the type of fault (upper limit, lower limit, disconnection, plausibility, etc.).
- BMW Fault Codes will alert the Technician of the current fault status. He/she will be advised if the fault is actually still present, not currently present or intermittent. The fault specific information is stored and accessible through DISplus/MoDIC.
- BMW Fault Codes determine the diagnostic output for BMW DISplus/MoDIC.

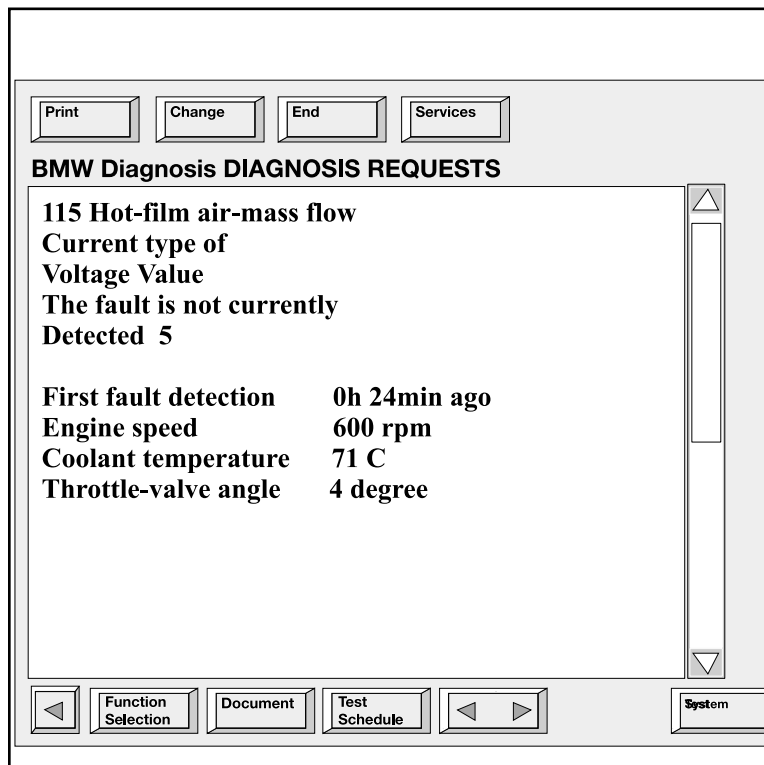

Workshop Hints

Before any service work is performed on any fuel system related component, always adhere to the following:

- | |
|---|
| • Observe relevant safety legislation pertaining to your area. |
| • Ensure adequate ventilation. |
| • Use exhaust extraction system where applicable (allivate fumes). |
| • DO NOT SMOKE while performing fuel system repairs. |
| • Always wear adequate protection clothing including eye protection. |
| • Use caution when working around a HOT engine compartment. |
| • BMW does not recommend any UNAUTHORIZED MODIFICATIONS to the fuel system. The fuel systems are designed to comply with strict Federal Safety and Emissions Regulations. In the concern of product liability, it is unauthorized to sell or perform modifications to customer vehicles, particularly in safety related areas. |
| • Always consult the REPAIR INSTRUCTIONS on the specific model you are working on before attempting a repair. |



The "**Malfunction Indicator Light**" can be diagnosed with an aftermarket Scan Tool that allows Technicians without BMW Special Tools or Equipment to Diagnose an emission system failure.

Further fault explanations can be found in the Service Information Bulletin SI # 16 05 97 **Evaporative Emission Control On-Board Diagnostic System.**

Refer to Service Information Bulletin S.I. #11 03 00 on Coolant Thermostat and Associated Fault Codes.

Misfire Detection

Refer to Service Information Bulletin **S.I. #12 02 97** for details about Misfire Fault Codes.

Checking Fuel Tank and Ventilation System for Leak-Tightness

Refer to the Repair Information Section **16 00 100** for procedures on testing the fuel tank/ventilation system. Refer to Service Information Bulletins SI # **04 26 00** and # **04 01 98** for the special tools and adapters to perform the Evaporative Leakage Diagnosis Test.

MS42

Refer to Service Information Bulletin S.I. #16 02 99 for **LDP Pump Operation** related fault codes.

IF the vacuum “T” (1) referred to in the SI is restricted, it must be replaced with a modified T-fitting **P/N 11 72 1 439 973**.

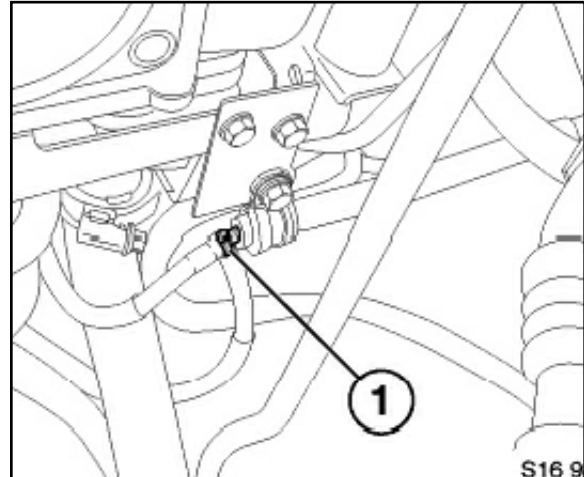

MS43

Refer to Service Information Bulletin S.I. #12 13 00 for **E46 DMTL FC 142 Stored in the ECM (DME)**.

Refer to p/n #16 13 1 184 849 for a “green dot”(1) below electrical connector(2).

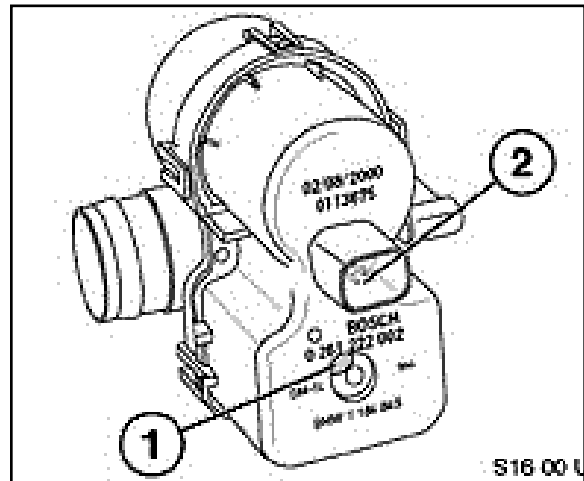

Malfunction Indicator Light Illuminated, “TANK LEAK” Fault Stored in the ECM (DME).

Refer to Service Information Bulletin SI #16 01 00 for details on the **Fuel Filler Cap**.

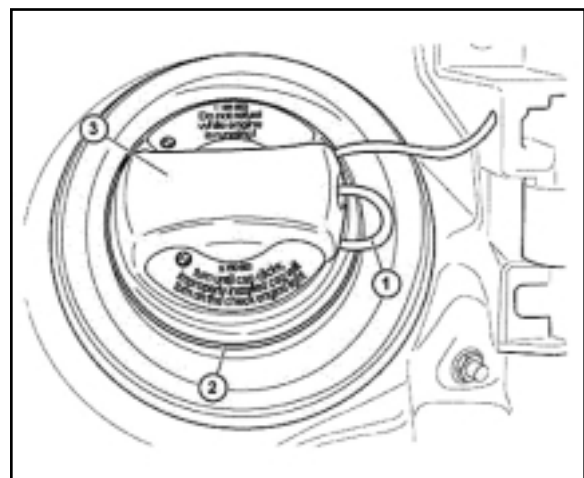

1. Pinched Retainer Strap
2. Insufficiently Sealed Cap
3. Cap Not Fully “Seated” When Installed

Testing the Oxygen Sensor should be performed using the DISplus Oscilloscope from the “Preset Measurement” List. The scope pattern should appear as below for a normal operating sensor.

If the signal remains high (rich condition) the following should be checked:

• Fuel Injectors
• Fuel Pressure
• Ignition System
• Input Sensors that influence air/fuel mixture
• Engine Mechanical

If the signal remains low (lean condition) the following should be checked:

• Air/Vacuum Leaks
• Fuel Pressure
• Input Sensor that influence air/fuel mixture
• Engine Mechanical

NOTE: A MIXTURE RELATED FAULT CODE SHOULD BE INVESTIGATED FIRST AND DOES NOT ALWAYS INDICATE A DEFECTIVE OXYGEN SENSOR!

For “Fault Access/O₂ Readiness Codes” refer to Service Information Bulletin S.I. #12 15 99 on Voluntary Emissions Recall 00E-A01.

Refer to Service Information Bulletin S.I. #12 04 98 on **Vacuum Hose to Secondary Air Non-Return Valve and Associated Fault Codes.**

1. Check for damage to the plastic tube.
2. Check for damage to the rubber hose.

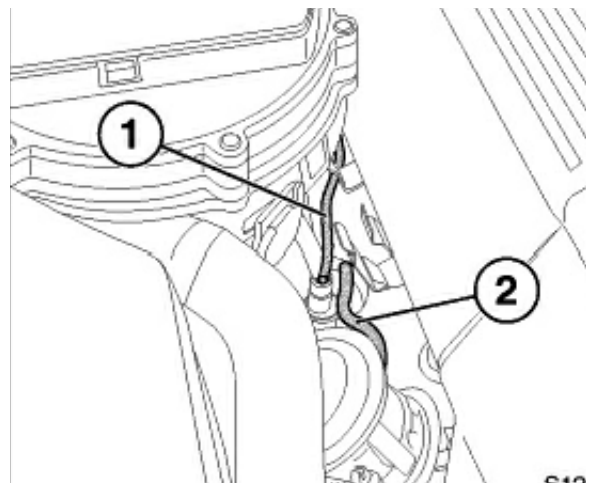

Tools and Equipment

The DISplus/Modic as well as a reputable hand held multimeter can be used when testing inputs/components.

It is best to make the checks at the ECM connection, this method includes testing the wiring harness.

The correct Universal Adapter for the MS42/MS43 application should be used (#90 88 6 121 300). This will ensure the pin connectors and the harness will not be damaged.

When installing the Universal Adapter to the ECM (located below the windshield on the passenger side of the engine compartment), make sure the ignition is switched off.

NOTE for MS43: Allow at least 3 minutes to elapse after the key was set to the "OFF" position before disconnecting the ECM/TCM. This will allow sufficient time to complete the DM TL test. Voltage may be present (up to 3 minutes) causing damage to the ECM/TCM if they are disconnected during this time period (arcing).

When checking the fuel tank and ventilation system for leak-tightness use Special Tool Set #90 88 6 161 170 which includes all of the pieces shown to the right.

1. Pressure Control Valve
2. & 3. Quick Coupling Adapters

This set is used in conjunction with shop supplied compressed air and the DISplus/Multimeter function for reading the pressure bleed off.

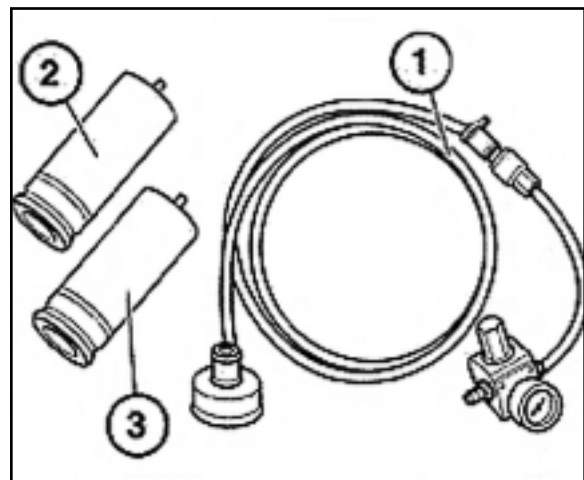
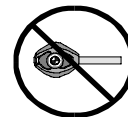
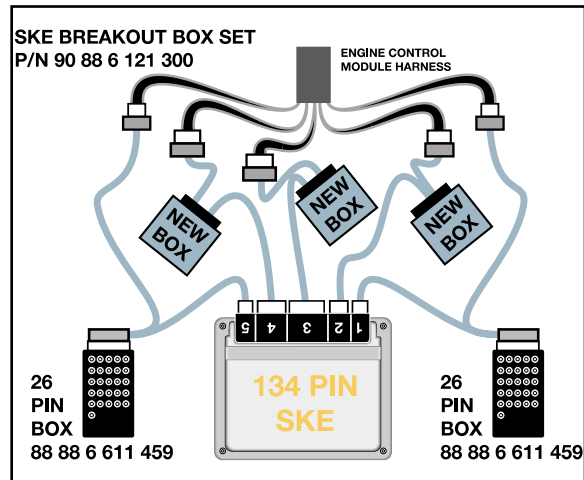
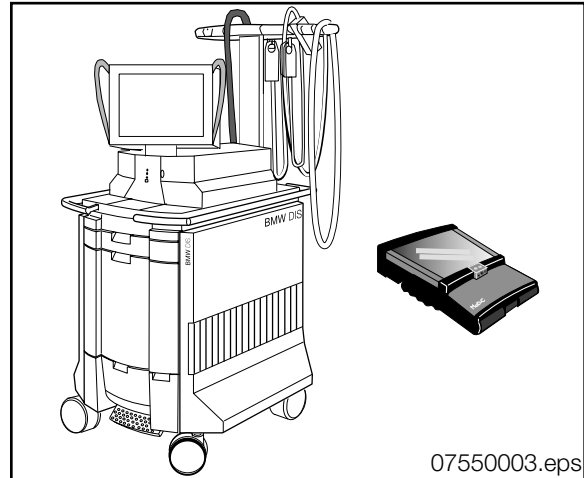

This Special Tool Set #90 88 6 161 160 will also be required to “cap off” the air filter and Evaporative Emission Valve hose when performing the Leakage Diagnosis Test.

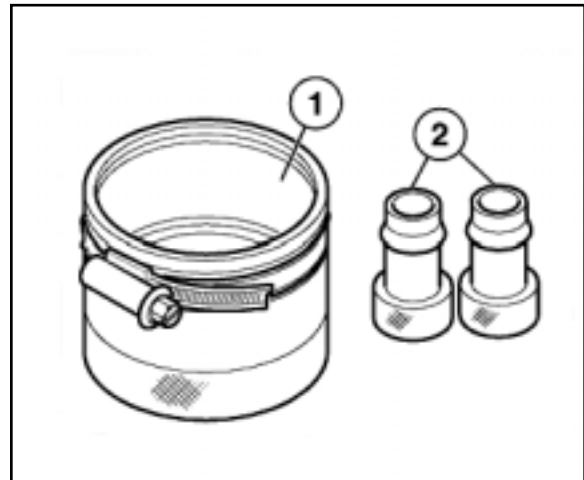

If the test indicates excessive bleed off an ultrasonic leak detector should be used (refer to Repair Instructions) to check for leaks at:

- Fuel Filler Cap and Filler Neck
- Fuel Tank Ventilation Lines
- Evaporative Emission Valve
- Fuel Tank and Fuel Sending Unit
- Liquid/Vapor Separator

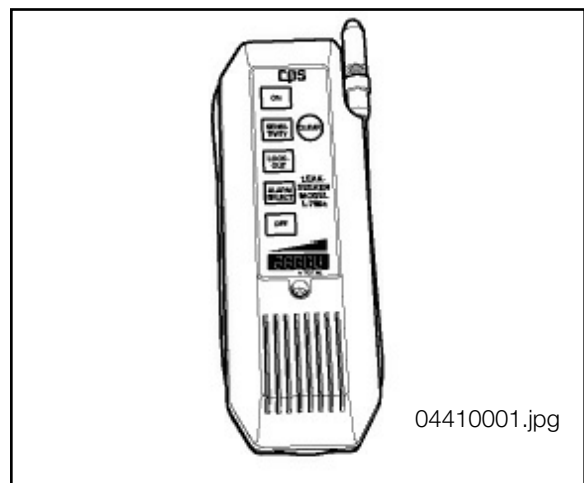

Performance Controls

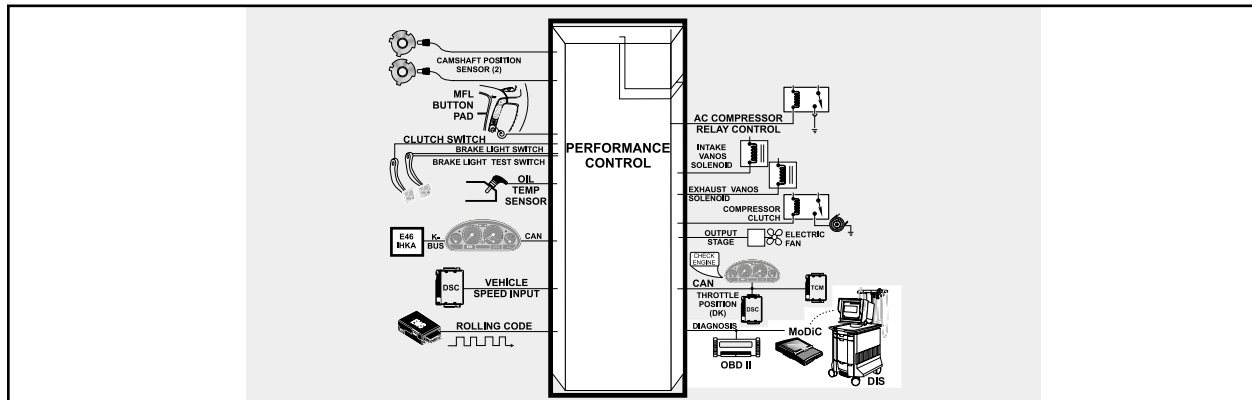

Cruise Control

Cruise control functions are activated directly by the multifunction steering wheel to the ECM. The individual buttons are digitally encoded in the MFL switch and is input to the ECM over a serial data wire. Cruise Control is integrated into the ECM because of the MDK/EDK operation.

- The ECM controls vehicle speed by activation of the Electronic Throttle Valve (MDK/EDK).
- The clutch switch disengages cruise control to prevent over-rev during gear changes.
- The brake light switch and the brake light test switch are input to the ECM to disengage cruise control as well as fault recognition during engine operation of the MDK/EDK.

Road speed is input to the ECM for cruise control as well as DSC regulation. The vehicle speed signal for normal engine operation is supplied from the DSC module (right rear wheel speed sensor). The road speed signal for cruise control is supplied from the DSC module. This is an average taken from both front wheel speed sensors, supplied via the CAN bus.

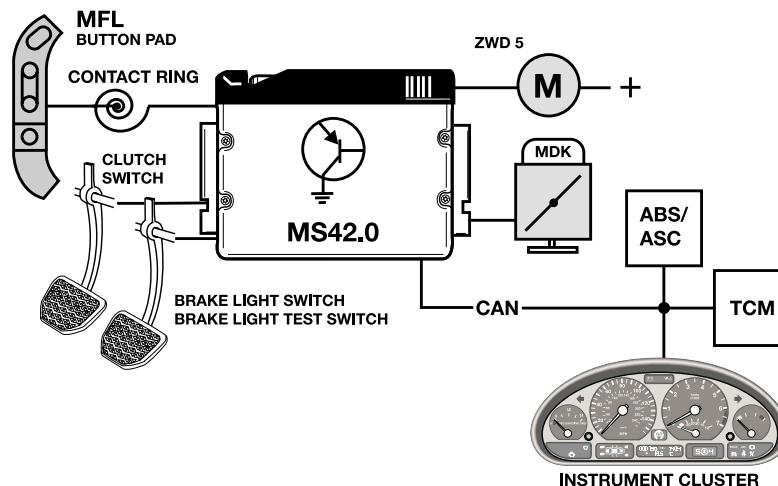

A/C Compressor Control

The ECM controls the A/C Compressor Relay based on signals from the IHKA/IHKR Control Module. The IHKR system in an E46 is shown here as an example.

The IHKR control module sends the following signals to the ECM over the K-bus-Kombi-CAN -bus connection:

- IHKR on stand-by (signal AC)
- Request for A/C activation (signal KO)
- Calculated compressor load
- Request for auxiliary fan

The IHKR determines the load torque for compressor activation and required auxiliary fan speed from the refrigerant pressure sensor mounted on the high side line next to the receiver/dryer.

The refrigerant pressure sensor provides a voltage input signal (0-5 volts) to the IHKR. The voltage value increases as pressure in the high side refrigerant circuit increases. The IHKR processes this signal to determine the calculated load that will be placed on the engine when the compressor is switched on. Pressure values that are too high or too low will cause the compressor to be switched off.

The ECM prepares for the additional load of the compressor by modifying the ignition timing and stabilizing idle speed.

Once all of the criteria for compressor operation have been met, the ECM will activate a ground circuit to the compressor relay to energize the compressor magnetic clutch.

The A/C Compressor Relay is deactivated during wide open throttle acceleration at low speeds to allow the engine to quickly achieve maximum power.

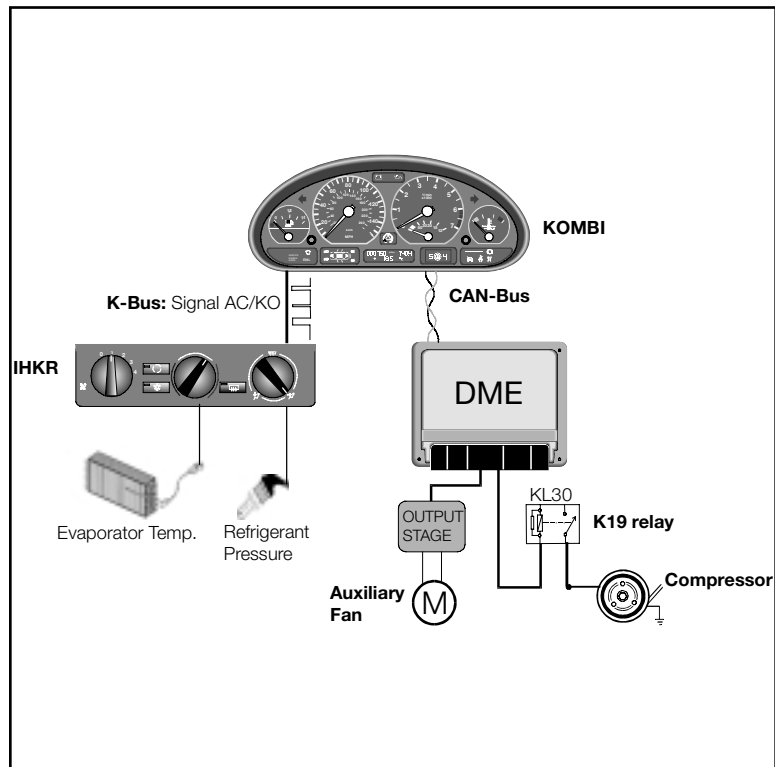

Electric Fan

The electric cooling fan is controlled by the ECM. The ECM uses a remote power output final stage (mounted on the fan housing). The power output stage receives power from a 50 amp fuse (E46 - located in glove box above the fuse bracket). The electric fan is controlled by a pulse width modulated signal from the ECM.

The fan is activated based on the ECM calculation (sensing ratio) of:

- Coolant outlet temperature
- Calculated (by the ECM) catalyst temperature
- Vehicle speed
- Battery voltage
- Air Conditioning pressure (calculated by IHKA and sent via the K-Bus to the ECM)

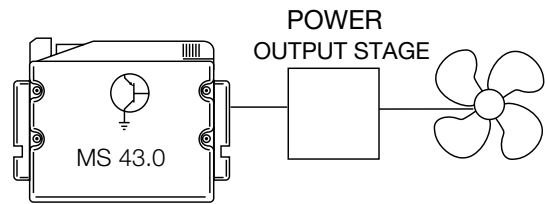

After the initial test has been performed, the fan is brought up to the specified operating speed. At 10% (sensing ratio) the fan runs at 1/3 speed. At a sensing ratio of between 90-95% the fan is running at maximum speed. Below 10% or above 95% the fan is stationary.

The sensing ratio is suppressed by a hysteresis function, this prevents speed fluctuation. When the A/C is switched on, the electric fan is not immediately activated.

Torque Interfaces

If torque reduction or increase is required for ASC/DSC/MSR/AGS, the ECM will regulate engine power in the following manner:

- If less torque is required, the ignition timing is reduced (fast intervention), the idle speed actuator and MDK/EDK reduce intake air.
- If increased torque is required (MSR), the idle speed actuator and MDK increase intake air.

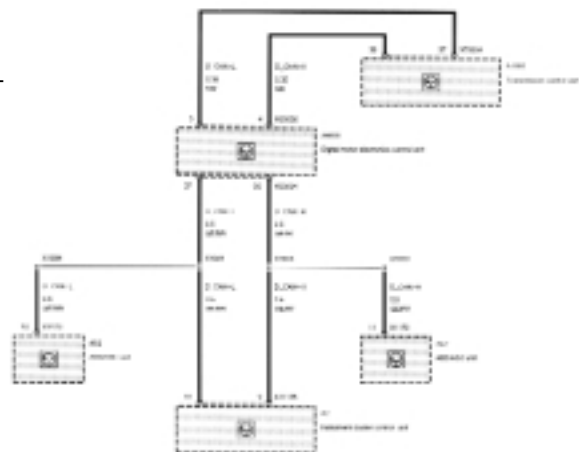

The data required for engine torque manipulation is relayed via the CAN bus.

Dual VANOS Control

Performance, torque, idle characteristics and exhaust emissions reduction are improved by Variable Camshaft Timing (VANOS). The VANOS unit is mounted directly on the front of the cylinder head and adjusts the **Intake and Exhaust** camshaft timing from retarded to advanced. The ECM controls the operation of the VANOS solenoid which regulates the oil pressure required to move the control piston. Engine RPM, load and temperature are used to determine VANOS activation.

VANOS mechanical operation is dependent on engine oil pressure applied to position the control pistons. When oil pressure is applied to the control pistons (regulated by the solenoids), the pistons move causing the splined adjustment shafts to move. The straight splines slide within the camshaft sleeves. The helical splines rotate the camshaft drive sprockets changing the position in relation to the camshaft position which advances/retards the intake/exhaust camshaft timing.

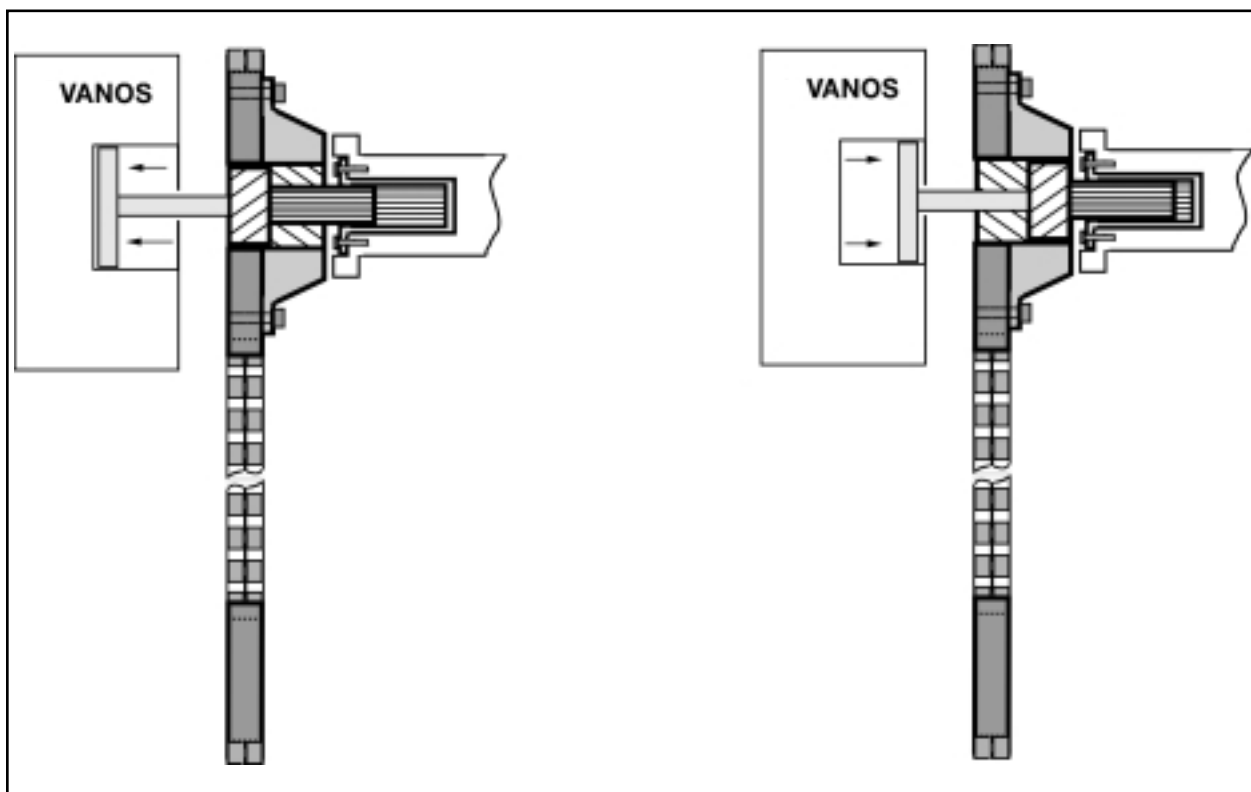

The operation of the VANOS solenoid is monitored in accordance with the OBD II requirements for emission control. The ECM monitors the final stage output control and the signal from the Camshaft Position Sensors for VANOS operation.

Dual VANOS consists of the following parts:

- Intake and exhaust camshafts with helical gear insert
- Sprockets with adjustable gears
- VANOS actuators for each camshaft
- 2 three-way solenoid switching valves
- 2 impulse wheels for detecting camshaft position
- 2 camshaft position sensors (Hall effect)

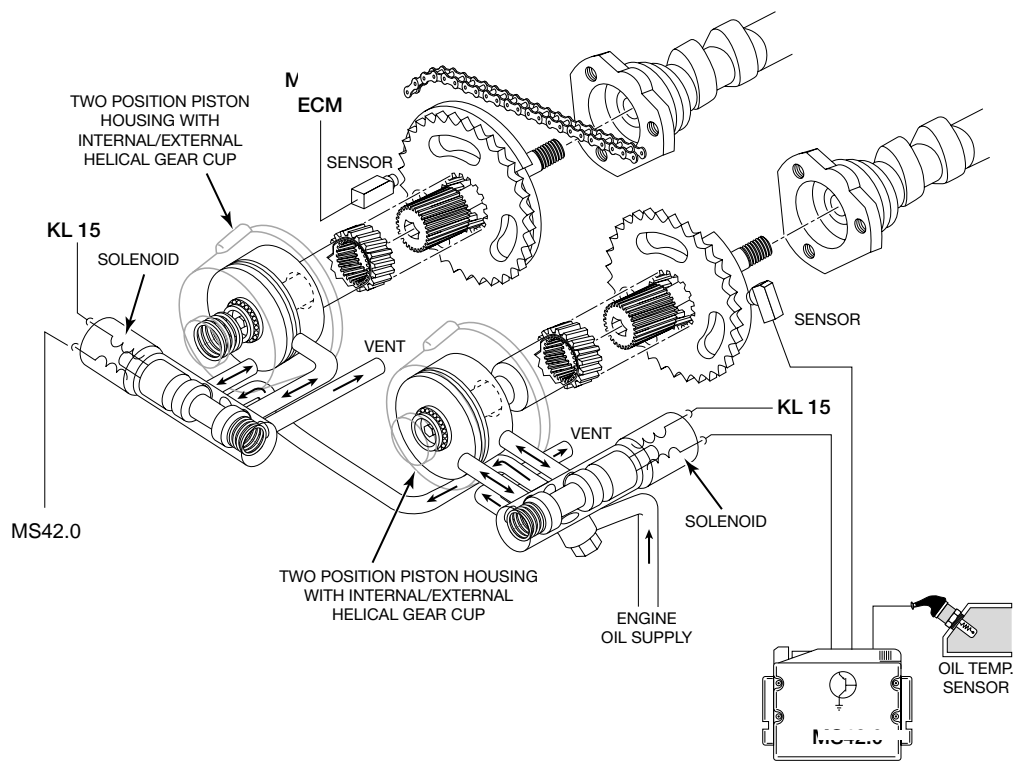

When the engine is started, the camshafts are in the “failsafe” position (deactivated). The intake camshaft is in the RETARDED position - held by oil pressure from the sprung open solenoid. The exhaust camshaft is in the ADVANCED position - held by a preload spring in the actuator and oil pressure from the sprung open solenoid.

After 50 RPM (2-5 seconds) from engine start, the ECM is monitoring the exact camshaft position. The ECM positions the camshafts based on engine RPM and the throttle position signal. From that point the camshaft timing will be varied based on intake air and coolant temperatures.

The dual VANOS system is “fully variable”. When the ECM detects the camshafts are in the optimum positions, the solenoids are modulated (approximately 100-220 Hz) maintaining oil pressure on both sides of the actuators to hold the camshaft timing.

CAUTION: The VANOS MUST be removed and installed exactly as described in the Repair Instructions!

NOTE: If the VANOS camshaft system goes to the failsafe mode (deactivated) there will be a noticeable loss of power.

DEACTIVATED

EXHAUST: Advanced - piston moved in

INTAKE: Retard - piston moved out

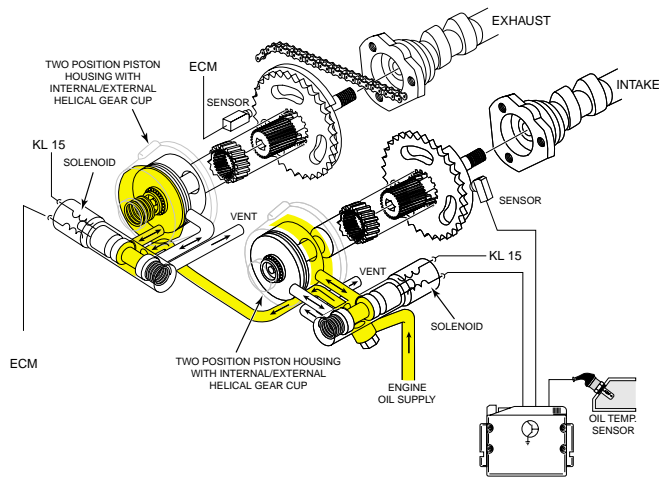

ACTIVATED

EXHAUST: Advanced - piston moved out

INTAKE: Retard - piston moved in

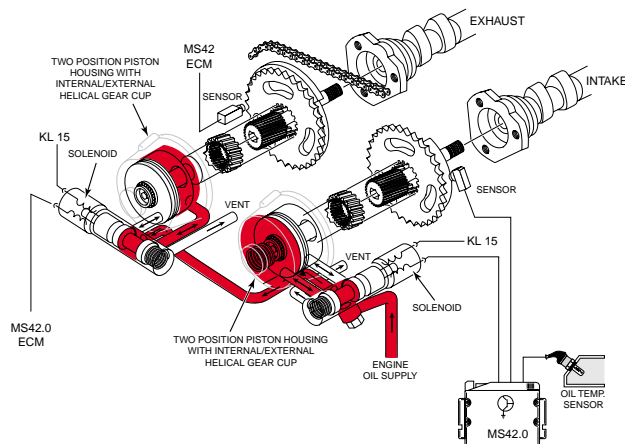

The dual VANOS in conjunction with the variable intake manifold provides an additional emission control feature.

Because of the improved combustion, the camshaft timing is adjusted for more overlap. The increased overlap supports internal exhaust gas recirculation (EGR) which reduces tailpipe emissions and lowers fuel consumption.

During the part load engine range, the intake camshaft overlap opens the intake valve. This allows limited exhaust gas reflow the intake manifold.

The “internal” EGR reduces the cylinder temperature thus lowering NOx. This feature provides EGR without the external hardware as seen on previous systems.

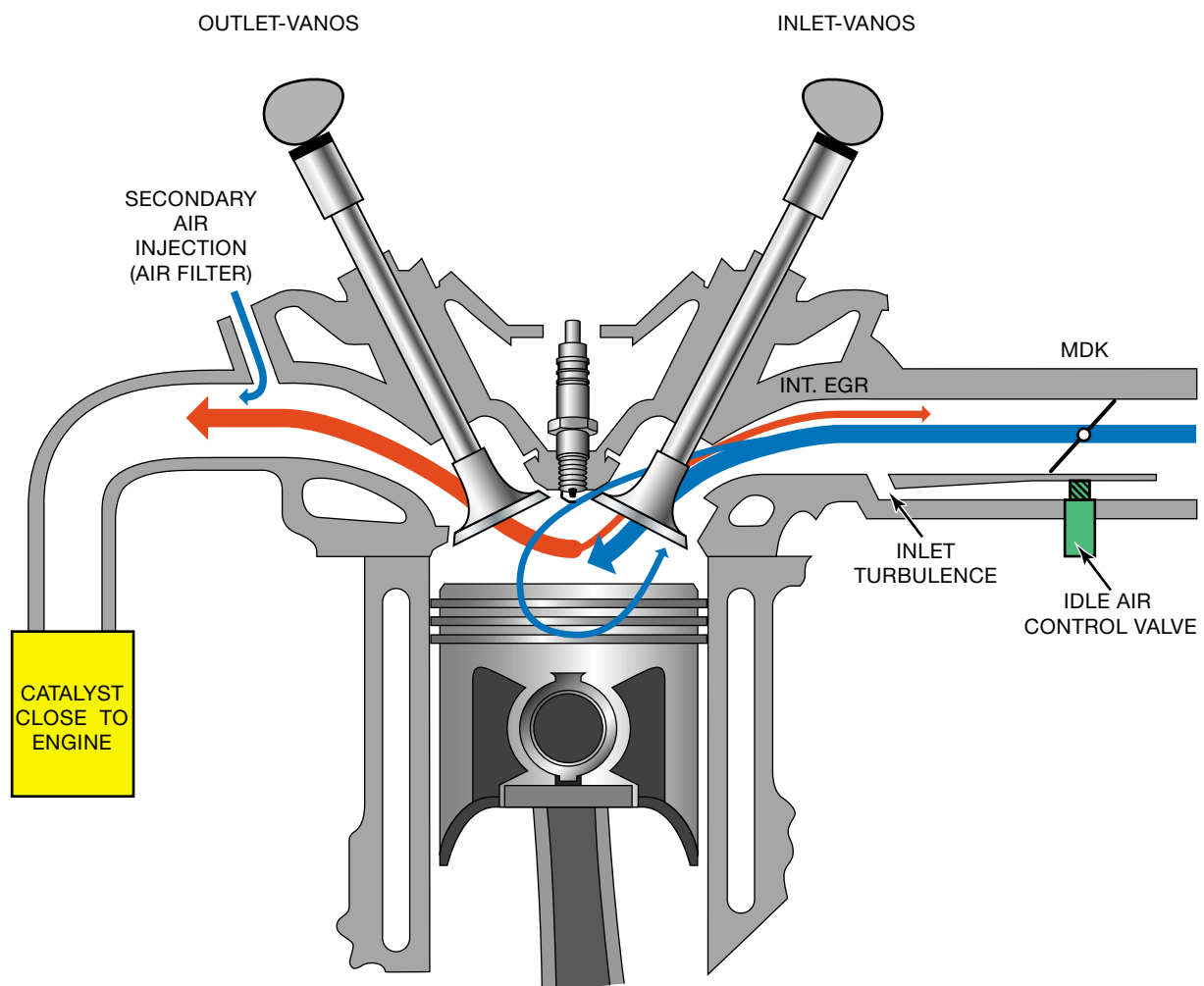

Exhaust Flap Damper Control (M54 - if equipped)

To meet European noise level compliance, the rear silencer incorporates a flap that is designed to reduce exhaust noise at idle, low rpm acceleration and while coasting. Components of the system include:

- Exhaust Flap with Vacuum Actuator
- Switching Solenoid
- Vacuum Reservoir

The ECM will power the switching solenoid and apply vacuum to the exhaust flap actuator to close the flap allowing additional damping of the exhaust.

The ECM will deactivate the solenoid when accelerating above 2500 RPM (approx.) under load. The vacuum is vented from the flap actuator and the flap opens. This decreases the exhaust backpressure for improved torque and acceleration.

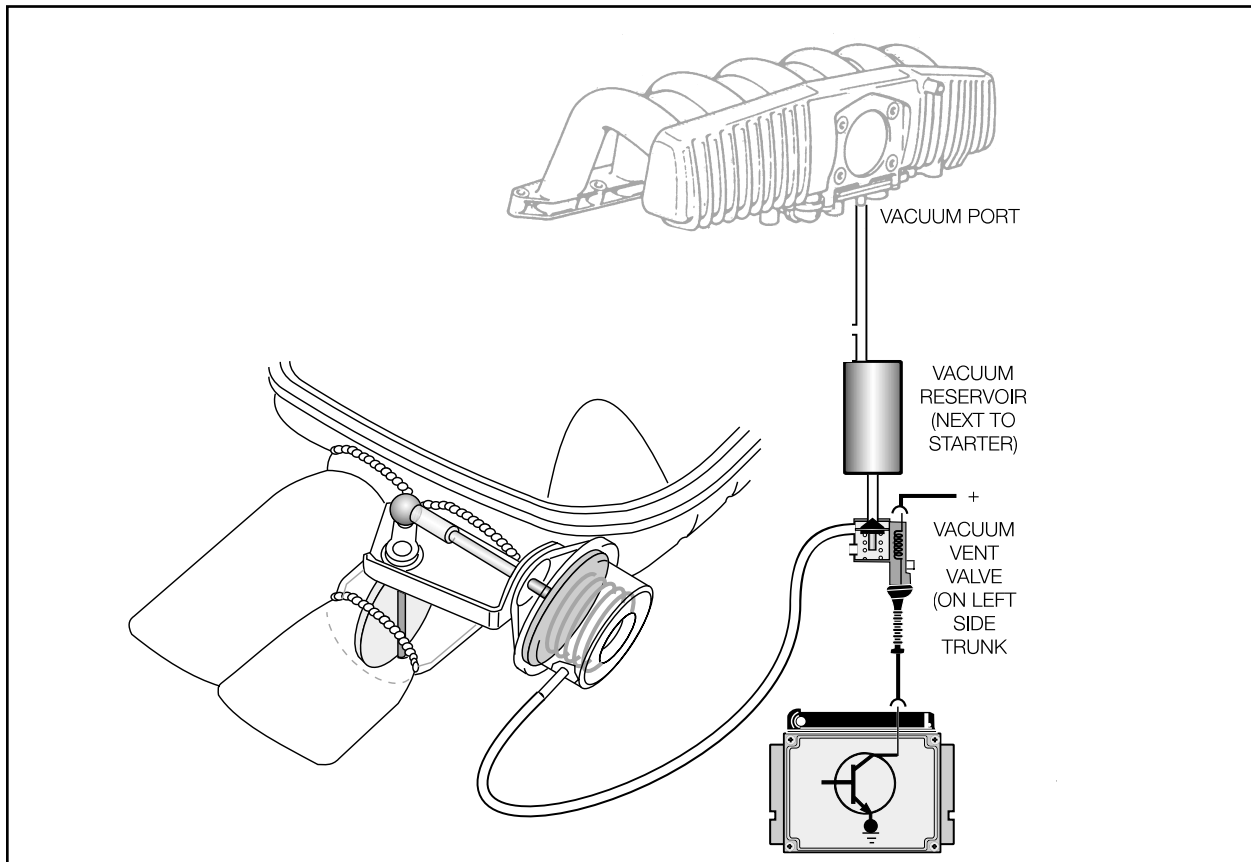

ECM Programming - FLASH Control Modules

The MS42/MS43 ECM is a programmable “FLASH” Control Module. The ECM contains a soldered in **FLASH EPROM** which can be programmed/updated up to 13 times. The EPROM has basic information always present in it referred to as “resident data”. This resident data gives the EPROM its identification and contains instructions for the programming of the operational maps. When you program, you are inputting operational maps to the ECM such as injection timing and ignition timing, etc.

Always refer to the latest programming IDC Bulletin for a complete list of FLASH programmable control modules and the latest program highlights. **An unprogrammed control module will not allow the engine to start.** DME (ECM) FLASH programming is performed with the DISplus/MoDIC using the latest software.

Using the “automatic” determination process (preferred method), the MoDIC compares the part numbers stored in the FLASH EPROM of the currently installed ECM with a list of possible replacement part numbers stored in the MoDIC’s memory. The comparison is done to:

- Display the part number for the replacement programmable control module for that vehicle.
- Determine if the MoDIC can “recommend” a replacement part number(s) from the list part numbers stored in its memory.
- Identify a proper replacement program or control module.

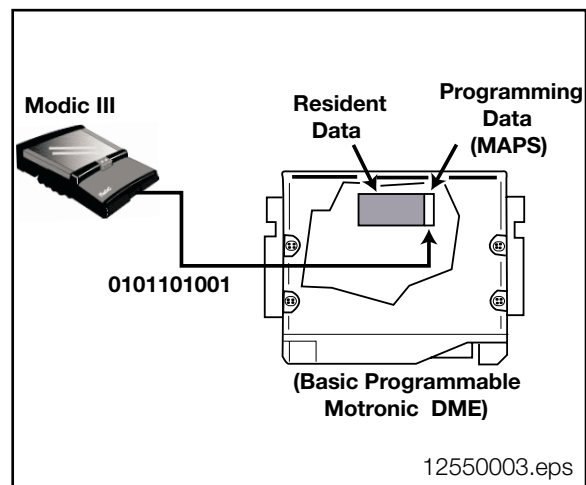

The determination identification screen is an example of the data displayed once the determination is made.

NOTE: Refer to Service Information Bulletin SI # 12 05 96 for detailed information on Programming FLASH Control Modules.

Refer to Service Information Bulletin #12 16 99 if **Reprogramming of Engine Control Module May Not Be Possible.**

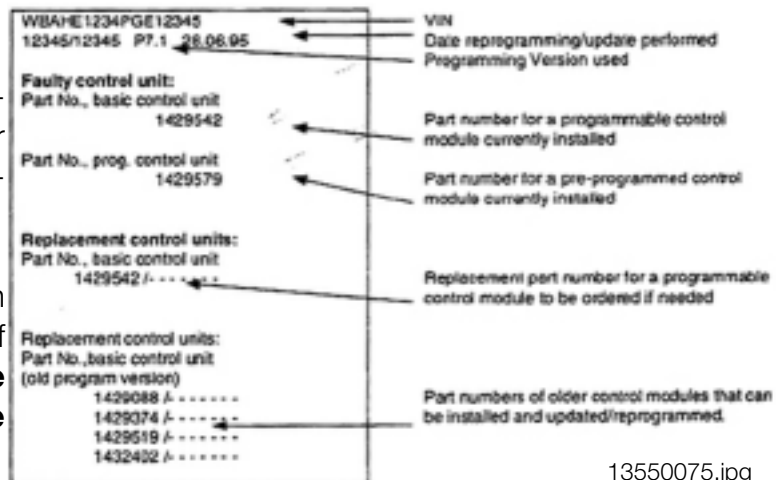

Tools and Equipment

The DISplus/Modic as well as a reputable hand held multimeter can be used when testing inputs/components.

It is best to make the checks at the ECM connection, this method includes testing the wiring harness.

The correct Universal Adapter for the MS42/MS43 application should be used (#90 88 6 121 300). This will ensure the pin connectors and the harness will not be damaged.

When installing the Universal Adapter to the ECM (located below the windshield on the passenger side of the engine compartment), make sure the ignition is switched off.

NOTE for MS43: Allow at least 3 minutes to elapse after the key was set to the “OFF” position before disconnecting the ECM/TCM. This will allow sufficient time to complete the DM TL test. Voltage may be present (up to 3 minutes) causing damage to the ECM/TCM if they are disconnected during this time period (arcing).

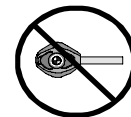
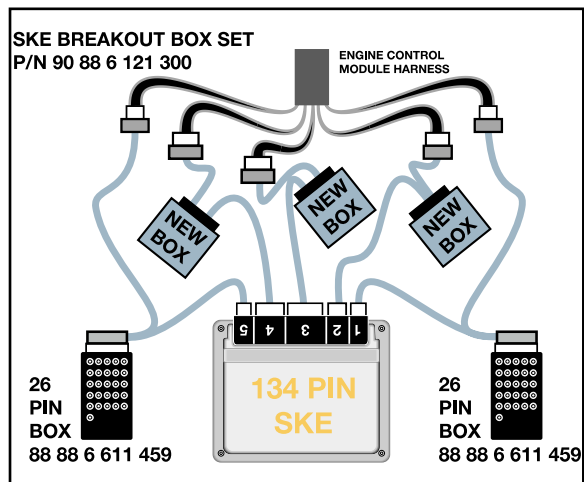
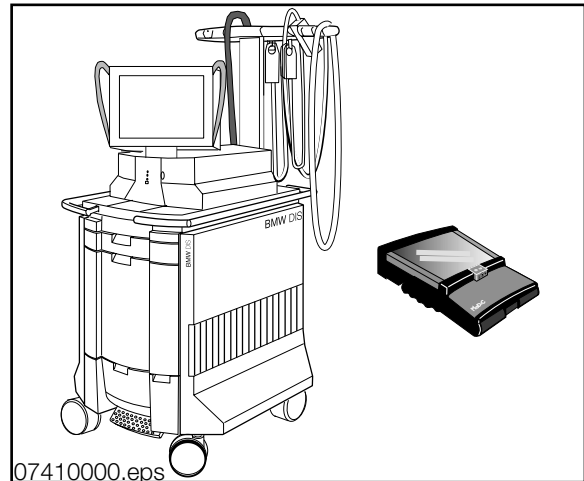

VANOS

The electrical/hydraulic function can be checked “statically” by using the adapter tools and shop supplied **regulated** compressed air.

Special Tool # 90 88 6 113 450 adapts regulated compressed air to substitute for engine oil pressure required to move the VANOS piston.

Special Tool # 90 88 6 126 410 allows battery voltage and ground to activate the solenoid.

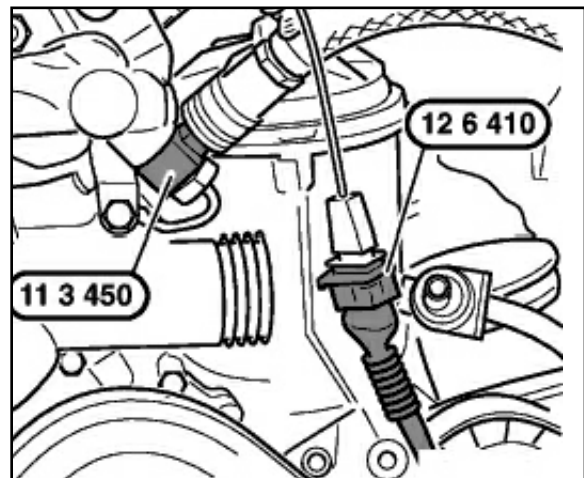

Review Questions

1. Describe the Power Supply for the MS43 Fuel Injectors and Ignition Coils:

2. Name the Components of the MS42 Fuel Supply System:

3. List the inputs required for Fuel Injector operation:

4. Describe the Emission Optimized Function: _____

5. Name two types of Emissions the ECM controls: _____

6. What two sensors are used to monitor MS43 accelerator movement?

7. Why are there two inputs from the Accelerator Module? _____

8. Where is the LDP located on an E46? _____

9. Why does the M42/M43 have multiple ignition pulses? _____

10. What is the Repair Instruction (number) for the procedure to perform a Leakage Diagnosis Test? _____

11. How is the ignition system monitored? _____
