

TAKTLHARDWARE Concealed Anchor Panel Attachment [Up-to-date version available here.](#)

Product Description:

- Extruded aluminum inter-locking clips and rails for concealed attachment of panel products.
- Custom clip widths are available for special load design criteria (panel weights > 500lbs) or very high windloads.
- Rails are available in 12ft, 16ft, and 20ft lengths. Allow overage for drops when ordering.
- Clips are attached to the back of the panel with undercut anchors, studs, or screws depending upon the panel type.
- Clips and rails accommodate seismic or regular building movement, while providing the means for direct fixing where necessary.
- Clips and rails are made from recycled content (may contribute to LEED certification for materials and resources).
- Made in the USA

Manufacturer + Distributor:

TAKTL LLC
230 Braddock Avenue,
Keystone Commons Portal 9
Turtle Creek, PA 15145
412-486-1600 | www.TAKTL-LLC.com

Installation Features:

- Clip extrusion profile is designed specifically for undercut anchors so that anchors mechanically engage the panel without transferring internal stress.
- Extrusions feature a channel to lock undercut anchors while driving the setting bolt and register the anchor depth for safe, accurate and reliable clip attachment.
- Registration grooves for self-drilling fasteners are integral to the clip and rail extrusions.
- Chamfered edges provide ease of panel installation.
- Panels are able to be removed individually (with open joints not less than 1/2in).
- Each clip has an integral closed-cell neoprene pad to separate the metal from cement-based materials and assist in proper anchor setting.

Primary Uses:

TAKTLHARDWARE is primarily used for exterior applications in back ventilated facade wall assemblies (rainscreen), with or without continuous exterior insulation. It is compatible with a wide range of sub-frame products and can be incorporated into assemblies and unitized curtain wall fabrications with horizontal and continuous rail orientation attached to a sub-frame/sub-girt system for:

- Close-cladding (without sub-girts) for concealed fixing with equal success for both interior finishes and exterior cladding
- Ceiling and soffit conditions
- Sloped roof applications with appropriate detailing and support system engineering
- Large and heavy panels

Limitations:

Use of **TAKTLHARDWARE** components, must be designed to comply with project performance requirements and design criteria as determined by a calculations report prepared, signed, and sealed by a qualified professional engineer. We strongly recommend single-source design and engineering of the cladding system even if multiple manufacturers are providing facade system components. Facade system engineering should include:

- On-center spacing of clips and rails
- Anchor, clip, and rail layout coordinated with the design and detailing of the entire wall assembly (sub-girts, sub-girt brackets, and wall substrate) using wind-load, seismic load, and structural performance criteria per the ASCE
- Allowance for thermal expansion of framing, floor deflections and building expansion in the design and sizing of connections and joints.

NOTE: Care must be taken to avoid direct contact between dissimilar metals.

TAKTL HARDWARE Concealed Anchor Panel Attachment [Up-to-date version available here.](#)

MATERIAL + MECHANICAL PROPERTIES

Clips + Rails Aluminum Alloy Description:

- 6005A-T5 aluminum alloy is tempered for use in structural and architectural applications in the commercial transportation, automotive, industrial, machinery and equipment industries.
- 6005A with T5 temper has excellent weld-ability and braze-ability using a variety of methods.
- Tempers meet the ASTM B 221, ASTM B 241, and ASTM B 429 specifications.
- Alloy is suitable for marine environments with "good" corrosion resistance.
- Paint finish is .08 mil high solid paint electrostatic (wet applied per AAMA 2603).
- Recycled Content: 40% pre-consumer recycled aluminum and 35% post-consumer recycled aluminum content. LEED Certification Documentation available upon request.

Average Coefficient of Thermal Expansion (68° to 212°F)	13.1 x 10 ⁶ (in/in °F)
Min Tensile Strength	38ksi
Tensile Strength Yield - 0.2% offset	31ksi
Typical Thermal Conductivity @77°F, BTU-in/ft 2hr °F (W/m-K@25°C)	1340 (193)
Average Thickness	0.118in (3.00mm)
Area	0.633in ² (408mm ²)
Weight	0.760lbs/ft (1.13kg/m)
Section Moduli	Sx(top): 0.342in ³
	Sx(left): 0.138in ³
Moment of Inertia	Sx(bottom): 0.449in ³
	Sx(right): 0.223in ³
Radius of Gyration	rx: 0.884in , ry: 0.402in
Max Span	32in under max uniform load

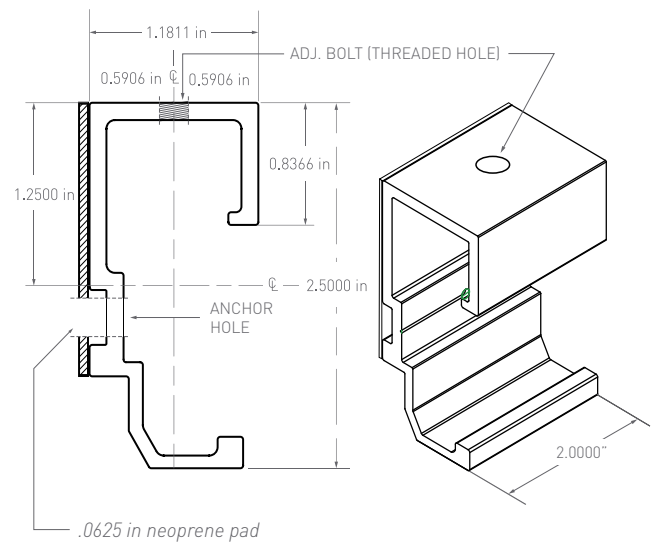

Anchors + Fasteners Stainless Steel Description:

- Undercut anchors and mated bolts are high-corrosion resistant – 316 Grade austenitic stainless steel.
- Adjustment bolts and fasteners are 304 Grade austenitic stainless steel.

HANDLING

- Check the shipping manifest for accuracy upon delivery. Notify TAKTL of any discrepancies with quantities or damaged product.
- Do not stack extrusions directly on the ground. Store bundled on a pallet that is flat to avoid damage.
- Store all materials dry, free of dirt, and covered until needed for installation.
- Provide protective padding when staging panels with clips installed to avoid surface damage to panels.

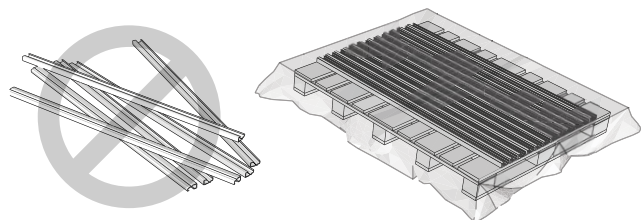

TAKTL HARDWARE Concealed Anchor Panel Attachment [Up-to-date version available here.](#)

INSTALLATION INSTRUCTIONS + DETAILS

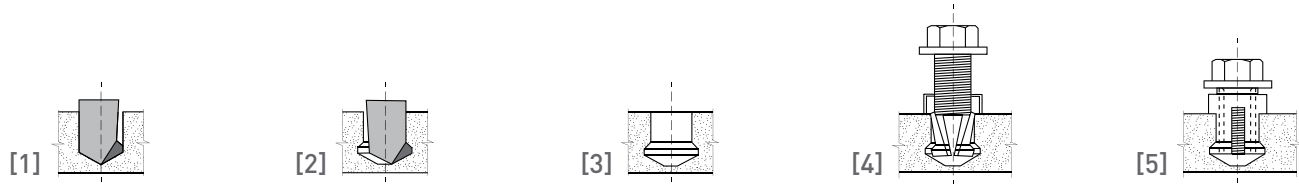

About KEIL Anchor Drilling:

- TAKTL factory-drills panels with undercut holes for KEIL Anchors exclusively.
- The undercut hole is produced in one step (cylindrical drilling [1] and undercutting [2]).
- Prescribed installation of the undercut facade anchor is possible only if a precisely undercut hole exists [3].
- The hole geometry is regularly monitored with the KEIL gauge matching the insertion depth of the anchor.

About KEIL Anchor Installation:

- The undercut anchor consists of an anchor sleeve and its hex screw.
- Hole, anchor sleeve and screw length have to be matched to the hole depth required and to the panel bracket chosen. Matching components are required for proper, safe, and quick installation.
- The anchor sleeve, which is compressed in the lower end, is placed in the hole together with the specified panel bracket [4].
- The screw is screwed in while exerting slight pressure on the panel bracket (to fix the anchor)[5].
- The locking mechanism of the screw cuts into the panel bracket to secure it. Thus, the panel bracket forms a rigid unit with the KEIL facade anchor.

Instructions | Installing Clips to Panels:

1. Confirm panel part number with shop drawings and anchor layout.
2. Check hole depth and confirm hole is clear of debris (2mm tolerance on depth checker). NOTE: A variation in depth of holes is allowable. Pullout strength for anchor holes drilled slightly deeper than KEIL's specification meets or exceeds the pullout strengths for TAKTL UHPC certified testing.
3. Insert the undercut anchor and place clip over it. Compress the clip to engage the anchor head with the clip channel so that the anchor cannot spin when the bolt is driven in. Using a cordless nut driver or ratchet wrench, tighten the bolt until it is set tight to the clip.
4. Check that the clip can rotate. This will confirm that the undercut anchor is installed properly and that the anchor is seated as intended (via mechanical connection, rather than expansion or friction connection).
5. Identify the top of the panel and install adjustment bolts set to 1/8in below the inner face of the rail wall.

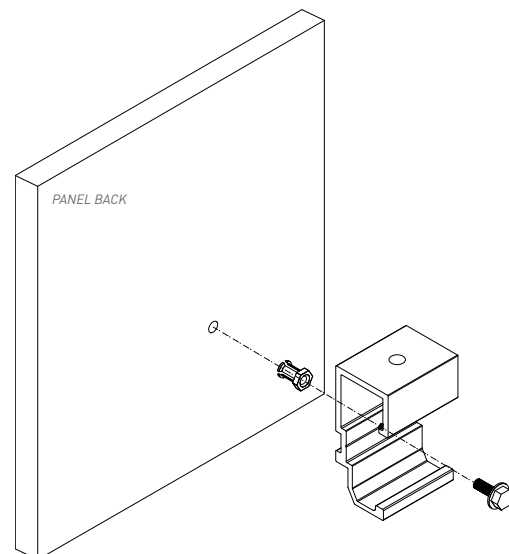

NOTE: Proper coordination of the clip thickness, anchor depth and bolt length is required for a safe and structurally sound connection. Only anchors, bolts, and clips supplied by TAKTL shall be used.

TAKTL HARDWARE Concealed Anchor Panel Attachment [Up-to-date version available here.](#)

INSTALLATION INSTRUCTIONS + DETAILS

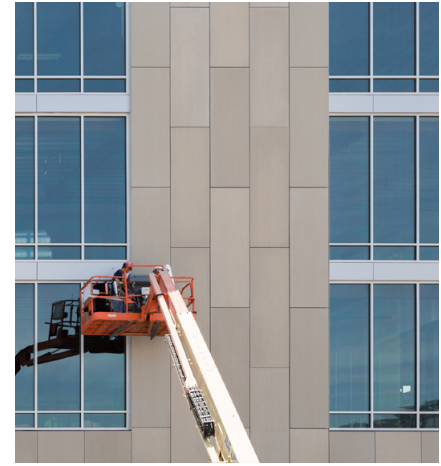
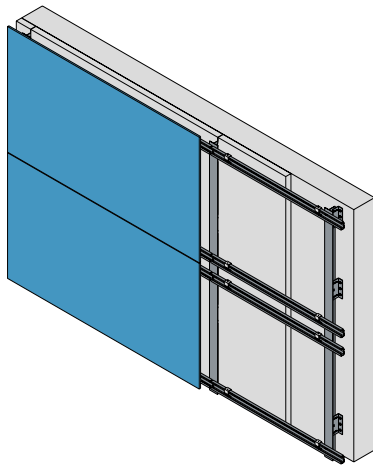

Instructions | Installing Rails to Sub-Frame:

1. Cut extrusions in the field with TCG non-chip, grind-proof saw blade with carbide teeth count 72-100 (10in diameter) or other recommended non-ferrous metal cutting methods.
2. Set elevations of rail datum/work points and locate rail positions per the approved shop drawings.
3. Note the offset of panel clip anchor location relative to the rail and layout rails accordingly (5/16in).
4. Install rails level, plumb, and true to the finished plane of the facade.
5. Fasten the rail to the sub-girts or back-up wall with self-drilling stainless steel screws (spacing, size, and thread of screws per the stamped engineer's calculations).
6. Allow space between joining rails' sections for expansion of aluminum (Example: $\pm 1/4$ in per 10ft, therefore minimum 1/2in gap between two 10ft rails).
7. Do not bridge rails with fixed connections to back-up wall across building expansion joint or seismic joints. Consult engineer and TAKTL for rail placement and panel layout details.

NOTE: When cutting extrusions, wear protective clothing and eye protection. File cut edges so they are free of burrs and sharp edges.

RECOMMENDATION: Touch up cut edges of extrusions with spray paint near corners where extrusions may be visible after panel installation.

Instructions | Installing Panels to Rails:

1. Set panels into position and ensure all clips are engaged with their respective rails.
2. Lower panels until the clips and rails interlock.
3. Adjust the panel position to achieve the specified joint dimension. Use shims to set a consistent joint width and level the panel.
4. Adjust bolts on the top row clips so that all are tight and in contact with the rail.
5. For projects that require seismic clips, consider panel orientation for installation: vertically oriented panels will require seismic clips on the top and bottom rails.
6. Once the adjustment bolts have been set, do not attempt to move the panel without backing off the adjustment bolts and lifting the panel to re-position.
7. For cladding with special design criteria, direct fastening of the clip to the rail may be required. The expansion and contraction of the rail must be allowed for, independent of the panel. Fasten a screw through the top of the clip on one end of the panel and a z-clip as a hold-down to the opposite end. Consult engineer and TAKTL for such requirements.

NOTE: See page 5 for installation examples without seismic clips. See page 6 for installation with seismic clips.

TAKTL HARDWARE Concealed Anchor Panel Attachment *Up-to-date version available here.*

Horizontally Oriented Panel (Example*)

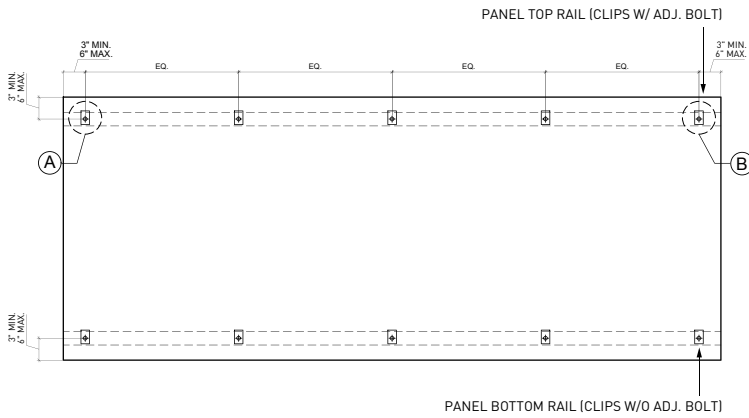

Vertically Oriented Panel (Example*)

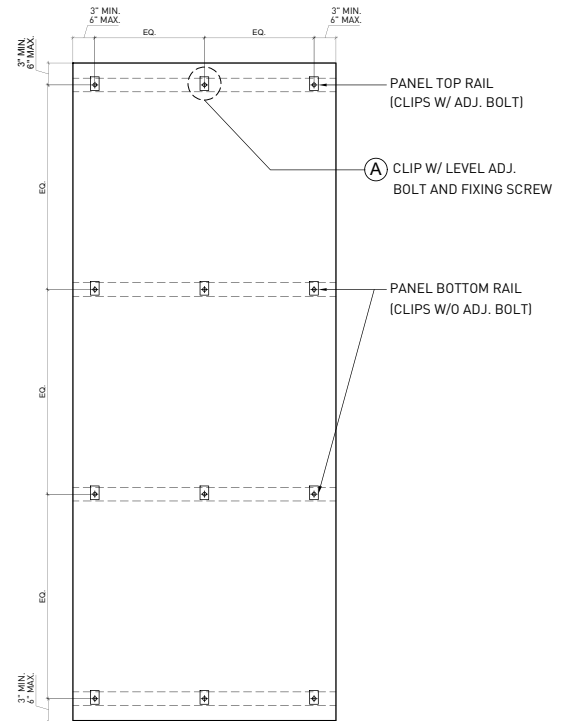

*Anchor spacing and direct fastening of clips to rails or hold-down clips are determined through evaluation of specific design criteria and engineering calculations.

A Fixing Screw Example*

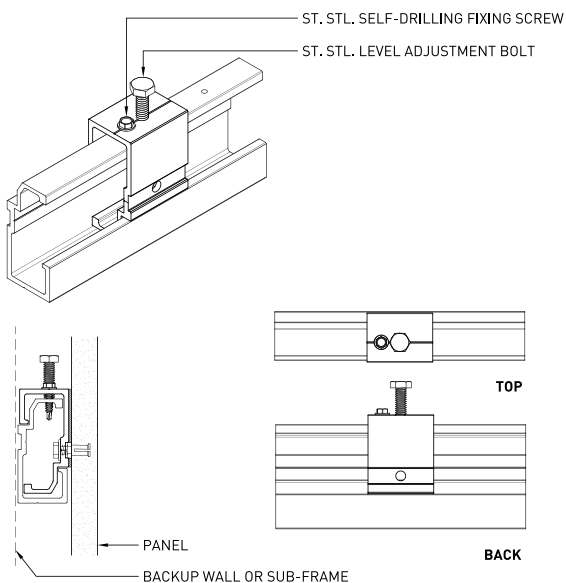

Fig. 1 | See A in drawing above

B 2-Clip Hold-down Example*

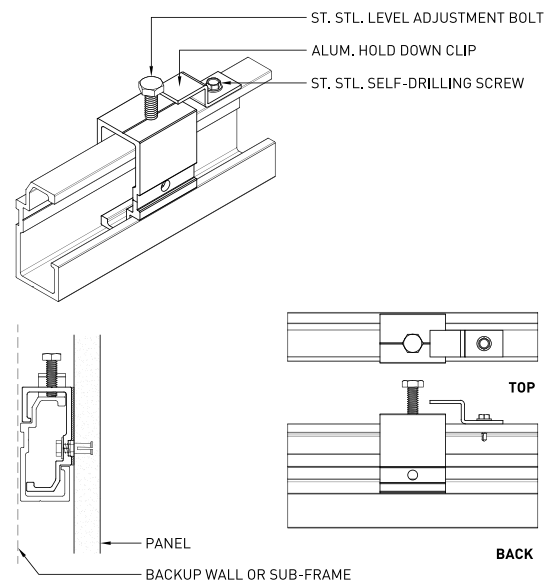
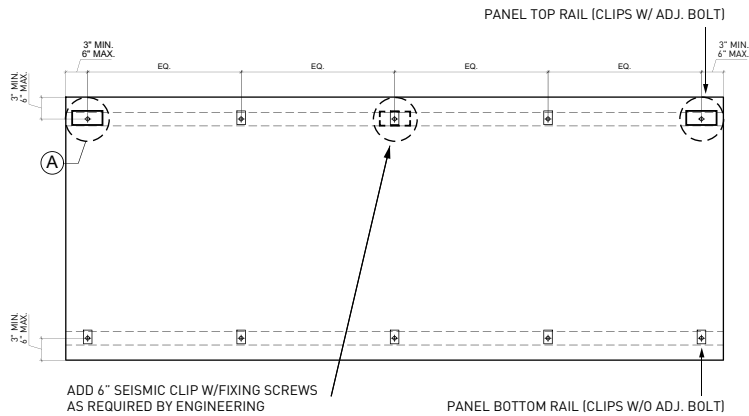

Fig. 2 | See B in drawing above

TAKTL HARDWARE Concealed Anchor Panel Attachment [Up-to-date version available here.](#)

Horizontally Oriented Panel With Seismic Clip (Example*)



Vertically Oriented Panel With Seismic Clip (Example*)

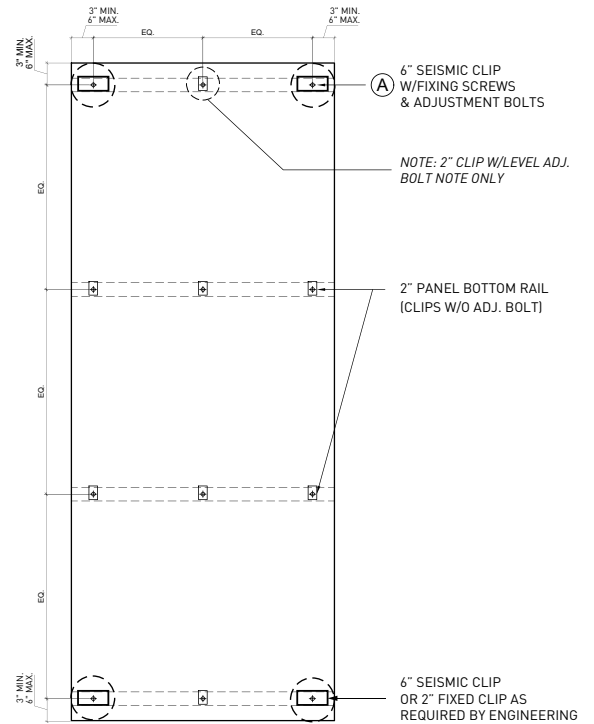

*Anchor spacing and direct fastening of clips to rails or hold-down clips are determined through evaluation of specific design criteria and engineering calculations.

(A) Fixing Screw Example*

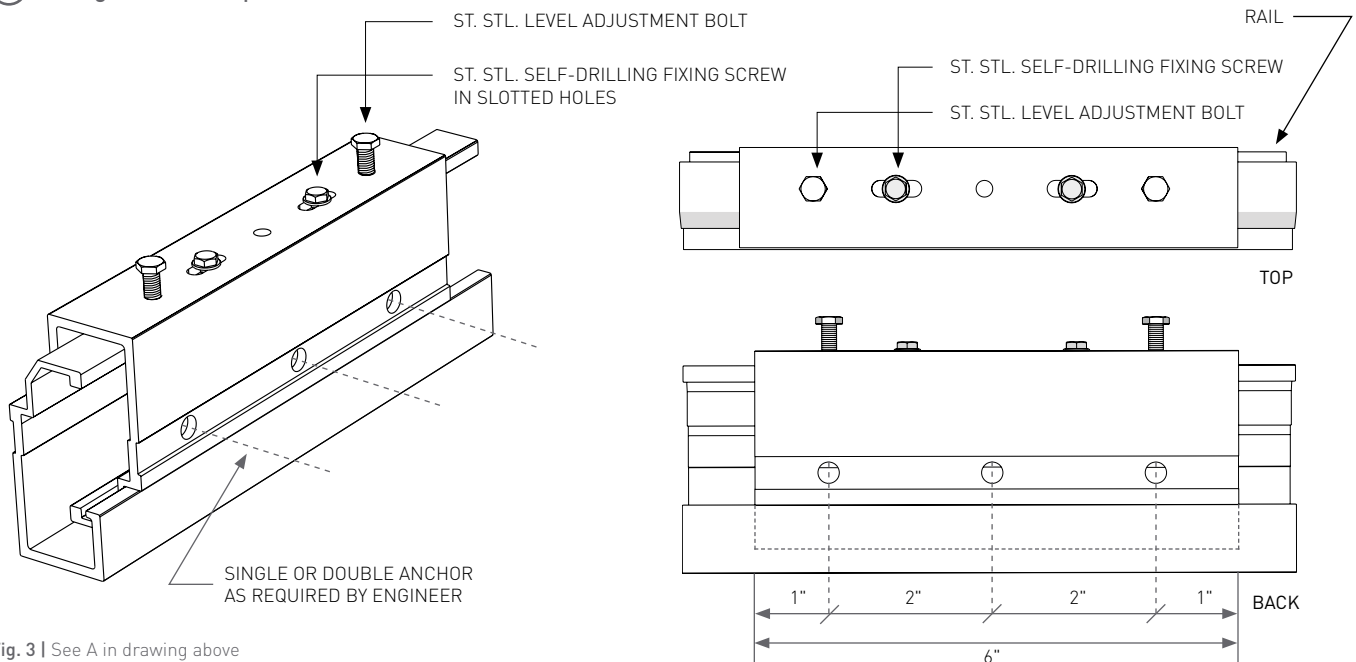

Fig. 3 | See A in drawing above