

# Operation Manual



## Tank Distribution System K-A-UPT Series

1020 Industrial Drive, Orinda, TN 37141

615-654-4441

sales@specialtyh2o.com

615-654-4449 fax



## **TABLE OF CONTENTS**

<b>Section 1</b>	<b>GENERAL</b>	
1.2	Warnings and Cautions.....	1
1.2	Theory of Operation.....	2
1.3	System Illustration .....	3
1.4	System Components .....	4
1.5	Modes of Operation.....	8
1.6	Touchscreen Functions .....	9
<b>Section 2</b>	<b>SPECIFICATIONS</b>	
2.1	Specifications .....	12
<b>Section 3</b>	<b>ROUTINE MAINTENANCE</b>	
3.1	Troubleshooting.....	14
3.2	Disinfection Procedure.....	15
3.3	Level Sensor Calibration.....	17
3.5	Routine Maintenance.....	18

**Section 1.1****WARNINGS AND CAUTIONS****WARNINGS** 

- Read this manual in its entirety before operating the 250 Gallon Ultra-Pure Distribution System.
- The “OFF” position does not disconnect power from the control box this must be done at the circuit breaker.
- The Manual Mode turns the pump on and it will run continuously. There is NO RUN DRY PROTECTION in the Manual Mode.
- Misuse, improper operation, and/or improper monitoring of this equipment could result in serious injury, death, or other serious reactions to the end users of the equipment.
- Routine maintenance of the system is required to protect the system from over-pressurizing and over-temperature which could result in damage to the facility, injury to staff, or the end users of the equipment.
- Routine disinfection of the tank and water distribution loop is required to prevent microbial proliferation. All company policies regarding disinfecting of water purification equipment must be adhered to.

**CAUTIONS** 

- When used as a medical device, Federal law restricts this device to sale by or on the authority of a physician. Per CFR 801.109 (b)(1).
- All local, state, and federal regulations regarding the installation and operation of this system must be observed.

**Section 1.2****THEORY OF OPERATION**

---

The 250 Gallon Ultra-Pure Distribution System is designed to store and deliver purified water.

The 250 gallon LPE (Linear Polyethylene) tank and control system communicates with a Reverse Osmosis system to fill, store and deliver purified water through a tank and loop piping system. With the use of non-intrusive level sensors installed on the tank, signals are communicated to the Reverse Osmosis machine to operate and produce purified water according to the water levels in the tank.

A Variable Frequency Drive control is used to operate a 2 or 3 HP Grundfos Pump that delivers the purified water through the piping system at a controlled rate. This is an electronic control system that manages flow and flow pressures in the water loop distribution system. The SWT Loop Pump VFD Controller utilizes a Variable Frequency Drive motor controller which quickly tunes to a set point and then maintains the loop velocity through the entire loop system. Water flows through the piping system and back into the storage tank through the loop return assembly.

Flow rates are easily verified and visualized through the GPM flowmeter attached to the loop return assembly. Also an injection port and static mixer are included for ease in the disinfection process. A 360 degree spray ball installed on the loop return aids in disinfection and prevents microbial proliferation in the tank.

The vent filter assembly provides an adequate pressure stabilization to prevent tank implosion and prevents microbial and viral proliferation in the tank.

Section 1.3

SYSTEM ILLUSTRATION



**Section 1.4****SYSTEM COMPONENTS**

*See illustration on previous page*

- 1. 250 Gallon Pure Solutions Tank:** The tank is constructed of Linear Polyethylene (LPE) which is designed for the purest processed waters. It is compatible with chlorine disinfectant, Minncare and ozone it has a conical shaped bottom which allows complete draining and aids in disinfection and prevention of microbial growth. The tank includes a pedestal stand and calibration scale.
- 2. Loop Return Assembly:** The Loop Return Assembly includes an Injection Port with Static Mixer which provides a safe method of adding disinfectant to the tank. The Static Mixer ensures adequate mixing of the disinfectant with the water.



**Injection Port**



**Static Mixer**

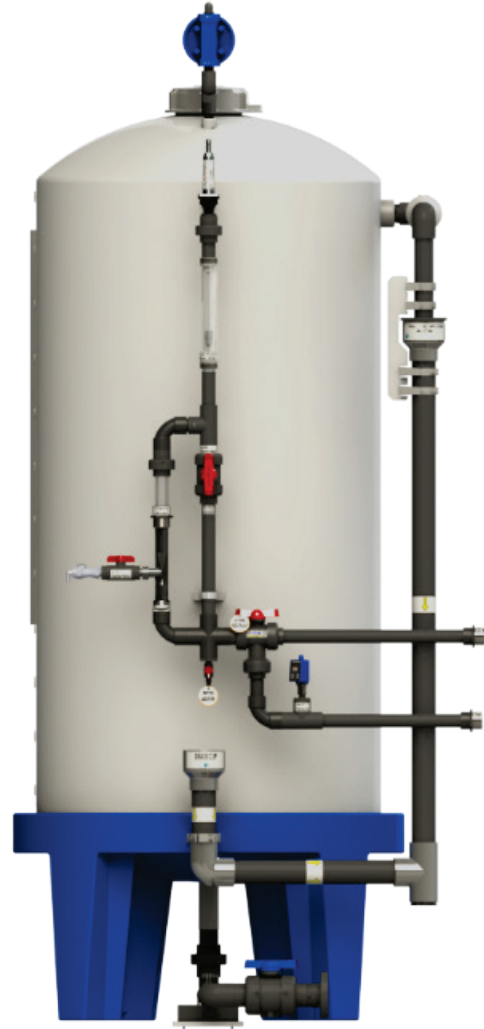

**Loop Return Assembly**

**Section 1.4****SYSTEM COMPONENTS**

- 3. Loop Pump VFD Controller:** The Loop Pump VFD Controller is an electronic control system that manages flow and flow pressures in a water loop distribution system. The *SWT Loop Pump VFD Controller* utilizes a Variable Frequency Drive motor controller which quickly tunes to a set point and then maintains the loop velocity through the entire loop system.

Included with the *SWT Loop Pump VFD Controller* is the loop return pressure sensor, three tank non-intrusive level sensors, low tank audio alarm, RO run signal, and pump run dry protection.

The system includes auto and manual modes of operation and operates the pump under significant noise reduction compared to existing pumps on the market.

The pump uses less amperage which results in electrical savings. In the event of a power failure, the system will restart automatically when power is restored



Section 1.4

SYSTEM COMPONENTS



←

**4. Vent Filter Assembly:** The Vent Filter Assembly is installed on the top of the tank to allow equalization of pressures. It houses a 0.2micron filter that prevents introduction of microbial or viral agents into the tank

**5. Overflow Air Gap Assembly:** The overflow air gap assembly provides protection from microbial and viral proliferation from drain pipes into the tank system



→

**6. Flow Regulator:** Increases flow for disinfection procedure. Adjustable to maintain return flow velocity.

**7. 360 Degree Tank Sprayer:** Rotating nozzle that provides 360 degree spray coverage. Placed on the loop return to aid in adequate disinfection of the tank.





**Section 1.4****SYSTEM COMPONENTS**

8. **Three-Way Valve, Loop to Drain Assembly:** Allows quick draining of water loop to minimize rinse times during disinfection.



**Section 1.5****MODES OF OPERATION****Auto “Automatic” Mode:**

Monitors the “Flow Switch” during normal operation and will shut pump off when a “No Flow” condition occurs.

System will tune pump to maintain the “pressure set point”.

Unit runs continuously in “Auto” until a “No Flow” condition occurs.

**Start / Run:**

Verify all valves in distribution on system are positioned correctly.

Select “AUTO” as “Mode of Operation”.

**Hand / Manual Mode:**

Verify all valves in distribution system are positioned correctly.

Pump will turn on immediately and run continuously.

System will tune pump to maintain the “pressure set point”

**WARNING! There is no pump protection in Manual Mode**



Section 1.6

TOUCHSCREEN FUNCTIONS



**Home Screen:**

Touch “Main” to proceed to next screen



**Main Menu:**

Select function

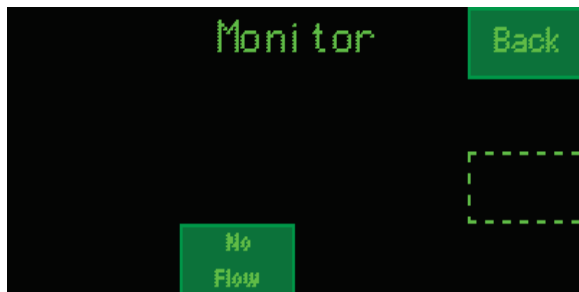

**Monitor:**

The indicator lamp the component will be illuminated when the state of the input is true or on.

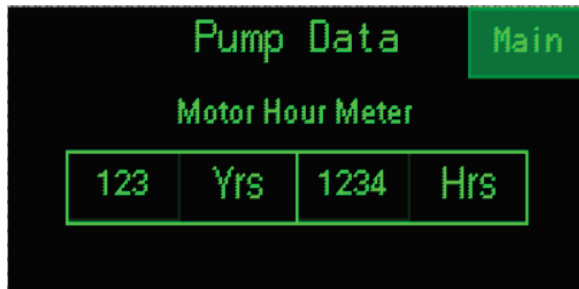

**Pump Data:** Displays the current hours that the pump has been turned on. Press “Main” to exit to Main Menu.

Section 1.6

TOUCHSCREEN FUNCTIONS

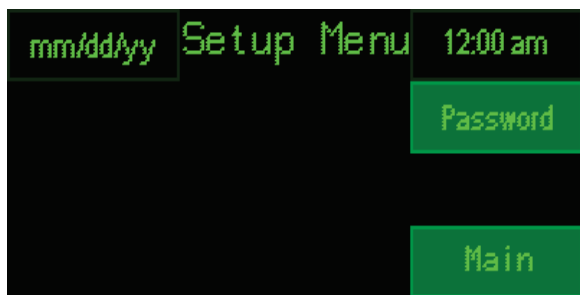

**Setup Menu:**

**Password:** When the correct user name and password are entered the user will gain access to make system function changes.



**Password Screen:**

When the user name and password is entered press the unlock key:



Then press menu key:



**Setup Menu:** Turns RO system on for a preset time defined by the user. The RO will remain on until the “Complete” button is pushed. System will then resume normal operation.

Allows user to enter a time between 15-20 minutes and will provide an audible alarm indicating to user that it is now safe to obtain media tank samples.

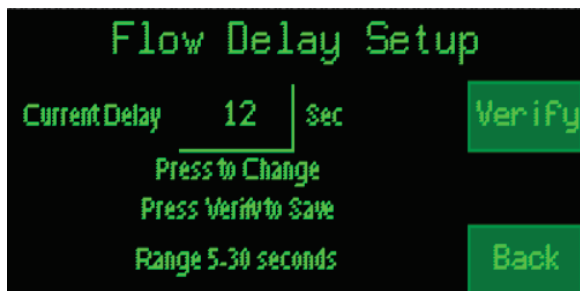

**Flow Delay:** Determines the amount of time the system will override the flow signal before turning pump off. The system will attempt x3 times to restart system before a pump fault is issued.

**Factory Default: 10 seconds.**

Section 1.6

TOUCHSCREEN FUNCTIONS



**Flow Switch Fault:** When the UPT system has unsuccessfully attempted to restart system for x3 times this fault will occur. Verify why system flow cannot be achieved and press “Retry”. The system will attempt to restart x3 times more.

Fault will clear when flow is obtained.



**I/O Menu:** Allows the user to view the status of each input and output.

Select a mode to view.

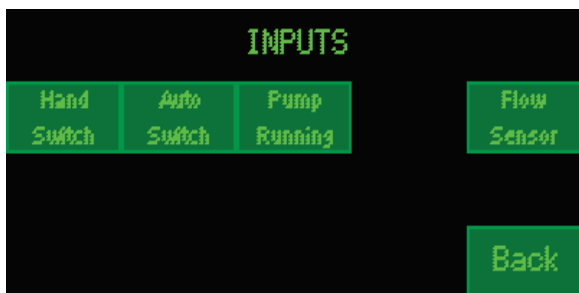

**Inputs:** The indicator lamp for each input will be on / illuminated when the state of the input is true or on.



**Outputs:** The indicator lamp for each output will be on / illuminated when the state of the input is true or on.

Each output can be turned to an “ON” state by pressing the button once. If the state of the button is already true or on then output cannot be turned off by pressing the button.

NOTE: Be sure to turn all outputs back to their original state before exiting.

**Section 2.1****SPECIFICATIONS****ELECTRICAL REQUIREMENTS:**

2HP: 208-230 volt, single phase 20 AMP dedicated circuit w/twist N lock receptacle.

3HP: 208-230 volt, single phase 30 AMP dedicated circuit w/twist N lock receptacle.

**DIMENSIONS & WEIGHT: TANK**

**Size:** 101”H x 44”W x 47”D

**Weight:** 130lbs (Dry)

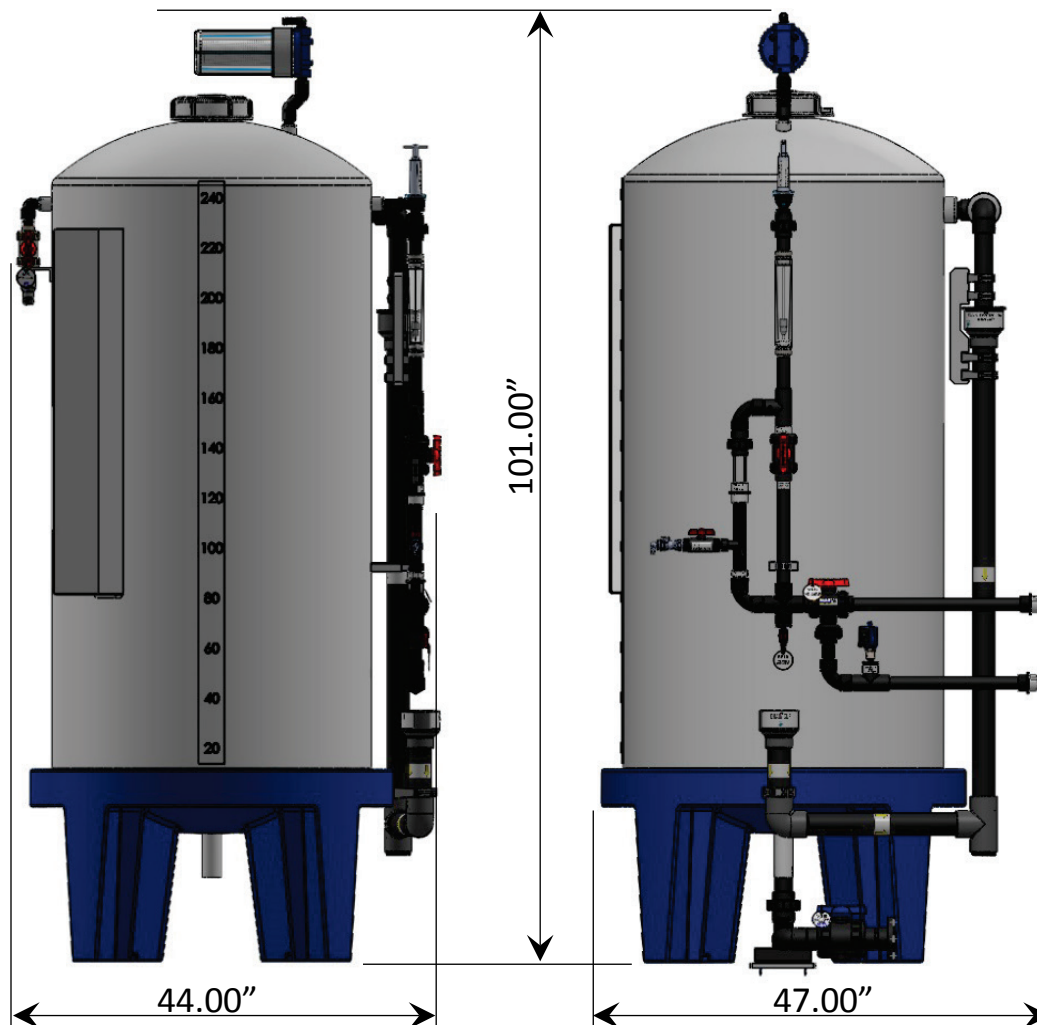

Section 2.1

SPECIFICATIONS

**DIMENSIONS & WEIGHT: PUMP**

**Size:** 54”H x 23”W x 20”D

**Weight:** 185lbs (Dry)

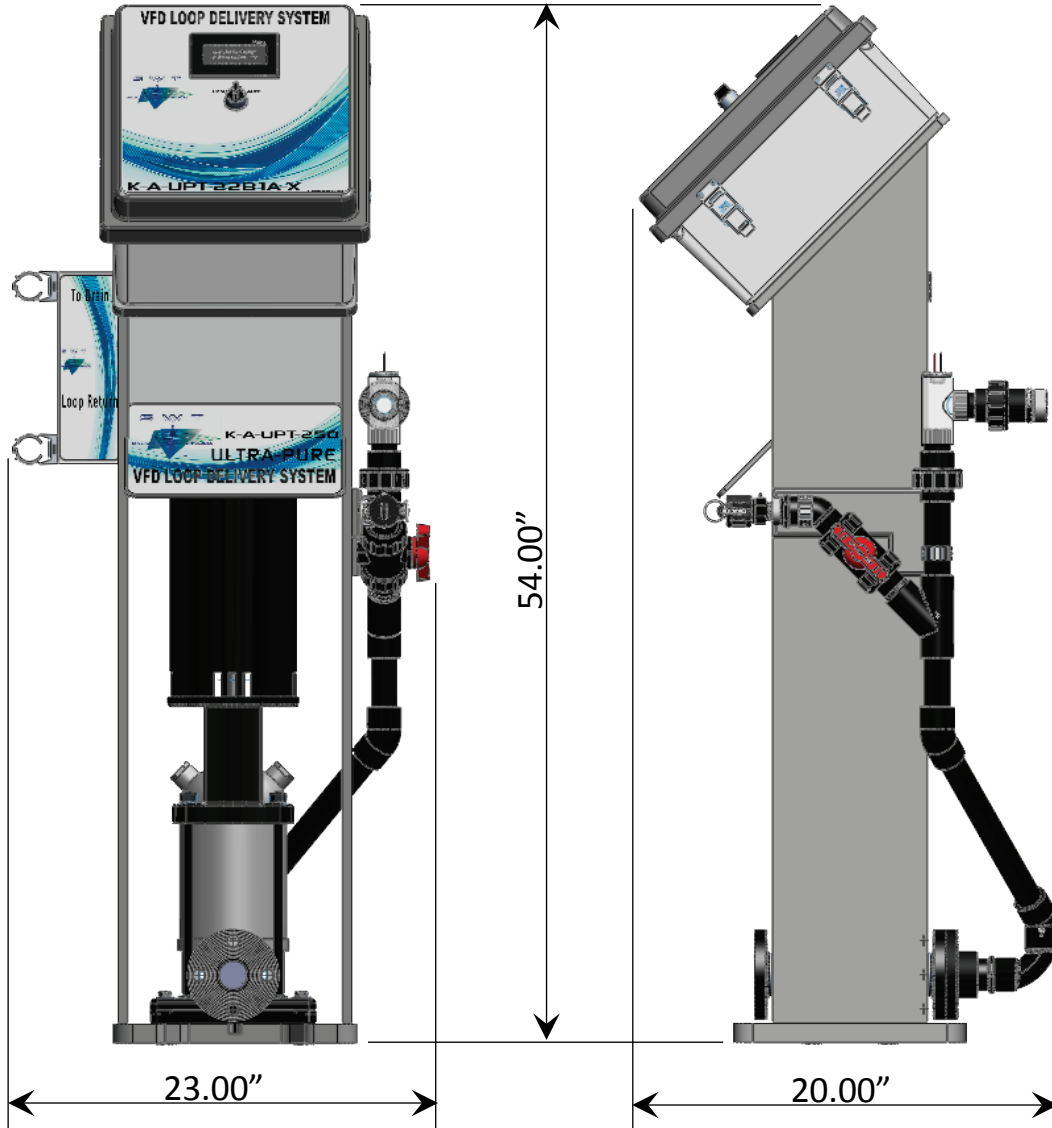

**Section 3.1****TROUBLESHOOTING****TROUBLESHOOTING GUIDE**

<b>Problem</b>	<b>Possible Causes</b>	<b>Possible Solutions</b>
The distribution pump shuts down for no apparent reason	Water level in tank.  Thermal Overload Tripped	If tank is empty check the RO troubleshooting guide.  If water is visible in the tank, check the circuit breaker for the pump. Reset if necessary.  Reset
Pump pressure discharge is reduced	Pump failing	Possible stage seal has failed. Call for technical assistance.
Pump does not build pressure	Pump rotation wrong	Check pump rotation - 3 phase circuit only  Ensure the air has been bled from the pump via the air bleed. If not air bled the pump can air lock.



**Section 3.2****BLEACH DISINFECTION PROCEDURE**

**\*\*\* Ensure there are no hemodialysis treatments in session**

**\*\*\* Do not expose UF membranes to bleach concentrations greater than 1:100 dilution.**

**\*\*\* Do not use 'splashless' or gel bleach.**

Refer to illustration on page 3 for component ID and location

**DISINFECT**

1. Turn RO OFF. Disconnect the RO Permeate Hose from the tank (V36.)
2. Turn UPT Delivery Pump OFF.
3. Connect the Disinfect Shunt Hose to the tank at (V36) and to the UPT at (V39) and open both valves.

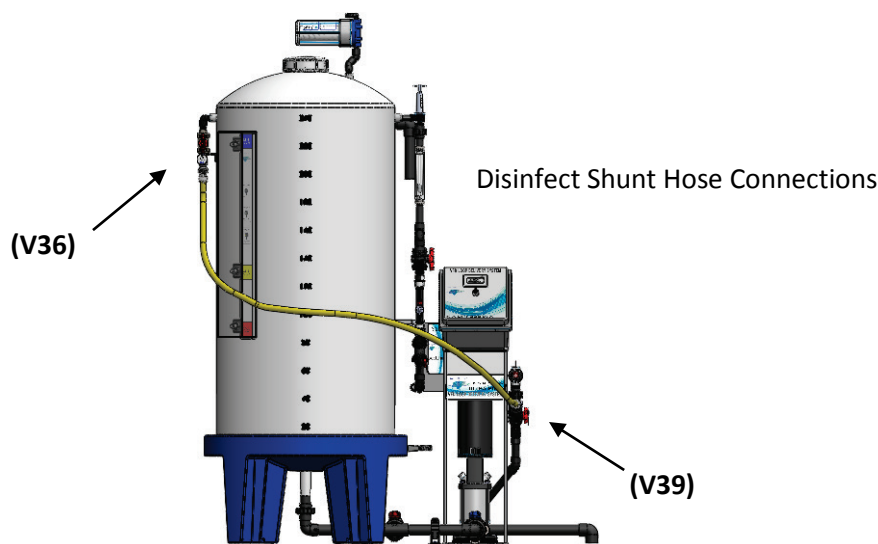

4. Open Storage Tank Drain (V37) and drain storage tank to approximately 100 gallons. Close (V37).
5. Start UPT Delivery Pump and verify flow is present.
6. Connect and place Uptake Injection Tube in *regular bleach* solution.
7. Open Loop Return Pressure / Flow Regulator to full flow.
8. Close Injection Throttle Valve (V48).
9. Open Chemical Suction Valve (V47). Solution will be drawn into tank through venturi.

**Section 3.2****BLEACH DISINFECTION PROCEDURE**

10. Hold Uptake Injection Tube upward to clear bleach from tube.
11. Close Chemical Suction Valve (V47) when solution is complete and disconnect tube.
12. Return Injection Throttle Valve (V48) to (half open) and Flow Regulator to operating position.
13. Recirculate or dwell as outlined in clinical policies and procedures.  
**Flush all sample ports during recirculation.**

**RINSE**

1. Turn UPT Delivery Pump OFF.
2. Disconnect the Disinfect Shunt Hose and connect the RO Permeate Line to the tank. (V36) should be open and (V39) closed.
3. Turn RO ON and leave running during the entire rinse process.
4. Close the Loop Pump Inlet (V38).
5. Open Storage Tank Drain (V37) and drain the storage tank completely.
6. Verify residual level of bleach at drain is <0.5ppm. (Allow system to continue flowing until <0.5ppm)
7. Close the Storage Tank Drain (V37) and allow tank to fill to approximately 50 gallons. (Leave RO ON)
  - a. While tank filling, position Loop Return (V46) to drain
  - b. Open Flow Regulator to maximum flow (fully CCW)
  - c. Open the Throttle Valve (V48)
  - d. Open SP10 Loop Return Sample Port to drain chemical injection assembly. (If may be necessary to pull down slightly on regulator tee handle to begin draining)
  - e. Close SP10
8. Upon reaching approximately 50 gallons open the Loop Pump Inlet (V38).
9. Prime the distribution loop pump.
10. Start the UPT Delivery System.
11. Monitor the drain flow at loop return DAG assembly for a chlorine residual level <0.5ppm. (Closely monitor the tank level during this operation and do not allow tank to go dry. If tank level does get low just turn UPT system off and allow level to rise back to 50 gallons and re-start UPT delivery system.)
12. Once drain flow is <0.5ppm position the Loop Return (V46) to Tank.

**Section 3.2****BLEACH DISINFECTION PROCEDURE**

13. Allow system to run in this state for 10 seconds. Turn off UPT pump.
14. Repeat rinse procedure steps 4-12 above. (RO should still be ON)
15. Monitor the drain flow at loop return DAG assembly for a chlorine residual level that meets clinic policy. (Closely monitor the tank level during this operation and do not allow tank to go dry. If tank level does get low just turn UPT system off and allow level to rise back to 50 gallons and re-start UPT delivery system.)
16. Position Loop Return (V46) to Tank.
17. Allow system to run in this state for 5 minutes.
18. Take chlorine sample at SP10 and verify chlorine residual level meets clinic policy. (If chlorine level does not meet clinical policy repeat step 14 above)
19. Return V48 to normal operation.
20. Adjust Flow Regulator to meet loop velocity.
21. Complete.

**Section 3.3****LEVEL SENSOR CALIBRATION**

**DESCRIPTION:** Specialty Water technologies utilizes State of the Art “Self-Calibrating” capacitance level sensors. The sensors sensitivity must be set for the wall thickness of the SWT Ultra-Pure tank.

Once the sensitivity is set, the sensor will self-calibrate itself for normal operation. This procedure should need only be performed once upon system setup.

**OBJECTIVE:** To set the sensitivity of the Balluff capacitance sensor to read thru the wall of the SWT Ultra-Pure Tank.

**NOTE:** This procedure works best when the tank is empty and should be performed prior to wetting tank during testing. “Relay Status” LED has no effect on calibration, disregard the status of this lamp during calibration. Small screwdriver (provided) must be used to calibrate sensors.

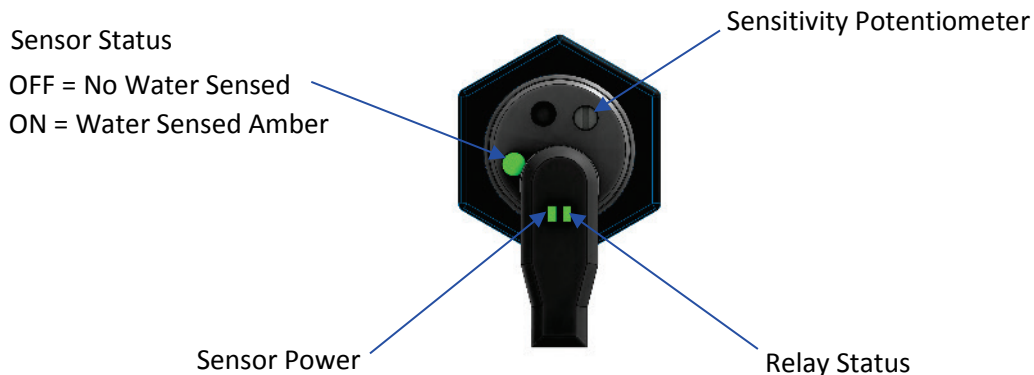

1. Verify that sensor is powered on and the “Sensor Power” LED is illuminated.
2. Verify tank is empty or water level is at least 10” below sensor that “sensitivity” is to be set.
3. The state of the “Sensor Status” is not important at this stage.
4. Adjust the “Sensitivity Pot” until the “Sensor Status” LED just turns on.  
CW=ON CCW=OFF
5. Adjust the “Sensitivity Pot” 1 turn CCW for each sensor.
6. Fill the tank and verify each sensor turns on “Sensor Status” LED is ON or amber. The transition should be between the red and blue lines as indicated on the “Range Scale” label attached the sensor mounting assembly.
7. If all sensors transition correctly, procedure complete. If not repeat steps 1-5 for the sensor in question.

CW—Clockwise CCW—Counterclockwise

**Section 3.4****ROUTINE MAINTENANCE**

Routine inspection of the system is recommended. Follow all facility procedures regarding regular inspection of electrical equipment.

Quarterly system should be inspected as follows:

- ◆ Unplug from wall outlet and inspect plug for signs of electrical burn. Inspect plug for frayed wires. Repair and replace as needed.
- ◆ Inspect and clean fan vents on left side and bottom of control box. Ensure adequate ventilation.
- ◆ Wipe exterior and inspect pump for dust and debris accumulation on top of fan shroud. Keep fan shroud clean.
- ◆ Inspect and clean glass on flowmeter for visual clarity.
- ◆ Over the course of time, the variation of temperatures, pressure and vibration may cause some threaded fittings to loosen. Tighten only enough to stop the leak. Overtightening may cause damage to the fitting.
- ◆ Check hand-tightened fittings (valve couplings) for leaks. Hand tighten only enough to stop leak. Overtightening may cause damage to the valve union.
- ◆ Inspect the flange mounts on each side of the pump for leaks. Tighten clamp bolts to 22 ft/lbs or just enough to stop the leak.

**S W T**

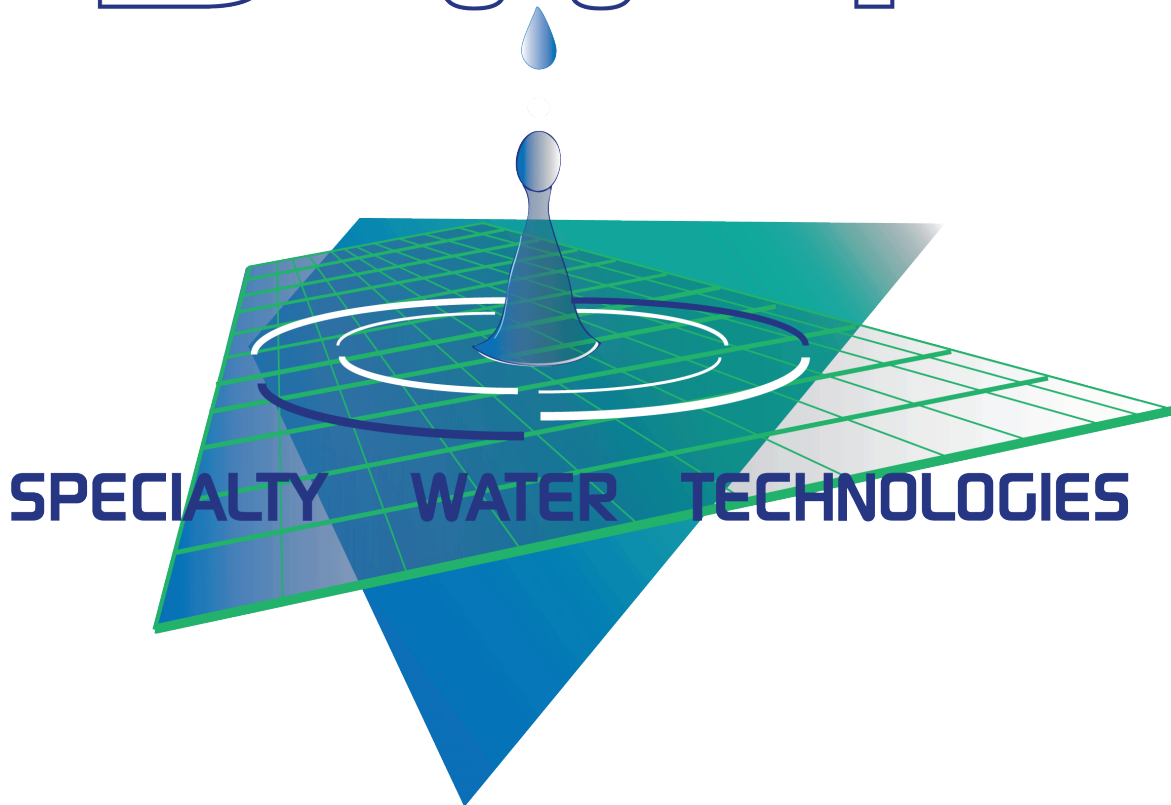

Operation Manual Ultrapure Tank K Model Rev. 12\_2017  
Manual P/N: OM-K-A-UPT-250

1020 Industrial Drive, Orlinda, TN 37141

615-654-4441

[sales@specialtyh2o.com](mailto:sales@specialtyh2o.com)

615-654-4449 fax