

IMPORTANT NOTE: Please follow the instructions on this sheet in order for the Martin bushing to perform satisfactorily.

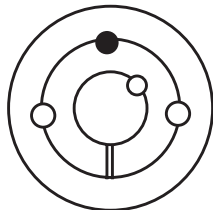

1008 to 3030

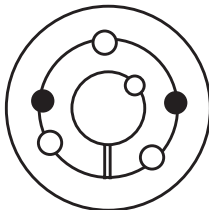

3535 to 6050

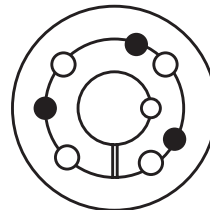

7060 to 10085

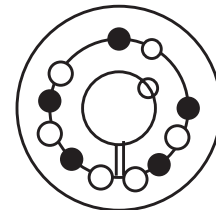

102100

INSTALLATION

1. Clean all oil, dirt, and paint from shaft, bushing bore, outside of bushing and component (sprocket, sheave...etc.) bore.
2. Insert bushing into component. Match the hole pattern, not the threaded holes (each hole will be threaded on one side only.)
3. Thread set or cap screws into those half threaded holes indicated by ○ on above diagram. Mount assembly on shaft.
4. Alternately torque set or cap screws* to recommended torque setting in chart below.
5. On 3535 and larger bushings use a block, sleeve or drift and hammer large end of bushing (do not hammer bushing directly).
6. Repeat steps 4 and 5 until torque wrench reading, after hammering, is the same as before hammering.
7. Fill all unoccupied holes with grease.

REMOVAL

1. Remove all set or cap screws.
2. Insert set or cap screws in holes indicated by ● on drawing. Loosen bushing by alternately tightening set or cap screws.
3. To reinstall, complete all seven (7) installation instructions.

RECOMMENDED TORQUE		
Bushing No.	Set Screw	Wrench Torque in/lb
1008, 1108 1210, 1215, 1310 1610, 1615	1/4 – 20 Socket Set Screw	55
	5/16 – 18 Socket Set Screw	165
	3/8 – 16 Socket Set Screw	175
	3/8 – 16 Socket Set Screw	175
2012 2317, 2525 3020, 3030	7/16 – 14 Socket Set Screw	280
	1/2 – 13 Socket Set Screw	430
	5/8 – 11 Socket Set Screw	800
3535 4040 4545	1/2 – 13 Socket Set Screw	1000
	5/8 – 11 Socket Set Screw	1700
	3/4 – 10 Socket Set Screw	2450
5050 6050, 7060, 8065 10085, 120100	7/8 – 9 Socket Set Screw	3100
	1-1/4 – 7 Socket Set Screw	7820
	1-1/2 – 6 Socket Set Screw	13700

If two bushings are used on same component and shaft, fully tighten one bushing before working on the other

CAUTION

WARNING: USE OF ANTI-SEIZE LUBRICANT ON TAPERED CONE SURFACE OR ON BOLT THREADS WHEN MOUNTING MAY RESULT IN DAMAGE TO SHEAVE AND SPROCKETS. THIS VOIDS ALL MANUFACTURER'S WARRANTIES

WARNING: Because of the possible danger to person(s) or property from accidents which may result from the improper use of products, it is important that correct procedures be followed: Products must be used in accordance with the engineering information specified in the catalog. Proper installation, maintenance and operation procedures must be observed. The instructions given above must be followed. Inspections should be made as necessary to assure safe operation under prevailing conditions. All rotating power transmission products when used in a drive are potentially dangerous and must be guarded by the user as required by applicable laws, regulations, standards, and good safety practice. (Refer to ANSI Standard B15.1.)

Taper Bushings Dimensions



No. 1008 to 3030 Taper Bushings

Bushing Number	Bore	Wt. lbs (appr)	Bushing Keyseat	Shaft Keyseat
1008	.5 to .563	.27	.125 x .063	.125 x .063
	.625 to .875	.21	.188 x .094	.188 x .094
	.938 to 1	.16	.25 x .063 ▼	.25 x .125
1108	.5 to .563	.33	.125 x .063	.125 x .063
	.625 to .875	.27	.188 x .094	.188 x .094
	.938 to 1	.22	.25 x .125	.25 x .125
	1.063 to 1.125	.17	.25 x .063 ▼	.25 x .125
1210	.5 to .563	.61	.125 x .063	.125 x .063
	.625 to .875	.55	.188 x .094	.188 x .094
	.938 to 1.25	.49	.25 x .125	.25 x .125
1215	.5 to .563	.8	.125 x .063	.125 x .063
	.625 to .875	.7	.188 x .094	.188 x .094
	.938 to 1.25	.6	.25 x .125	.25 x .125
1310	.5 to .563	.7	.125 x .063	.125 x .063
	.625 to .875	.7	.188 x .094	.188 x .094
	.938 to 1.25	.6	.25 x .125	.25 x .125
	1.313 to 1.375	.6	.313 x .156	.313 x .156
1610	.5 to .563	.9	.125 x .063	.125 x .063
	.625 to .875	.8	.188 .094	.188 .094
	.938 to 1.25	.7	.25 x .125	.25 x .125
	1.313 to 1.375	.7	.313 x .156	.313 x .156
	1.438 to 1.5	.6	.375 x .188	.375 x .188
1615	.5 to .563	.9	.125 x .063	.125 x .063
	.625 to .875	.8	.188 .094	.188 .094
	.938 to 1.25	.7	.25 x .125	.25 x .125
	1.313 to 1.375	.7	.313 x .156	.313 x .156
	1.438 to 1.5	.6	.375 x .188	.375 x .188
2012	.5 to .563	1.2	.125 x .063	.125 x .063
	.625 to .875	1.1	.188 x .094	.188 x .094
	.938 to 1.25	1.0	.25 x .125	.25 x .125
	1.313 to 1.375	.8	.313 x .156	.313 x .156
	1.438 to 1.5	.7	.375 x .188	.375 x .188
2517	.5 to .563	1.7	.125 x .063	.125 x .063
	.625 to .875	1.6	.188 x .094	.188 x .094
	.938 to 1.25	1.5	.25 x .125 ▼	.25 x .125
	1.313 to 1.375	1.4	.313 x .156	.313 x .156
	1.438 to 1.75	1.2	.375 x .188	.375 x .188
2525	.5 to .563	3.5	.125 x .063	.125 x .063
	.625 to .875	3.4	.188 x .094	.188 x .094
	.938 to 1.25	3.3	.25 x .125	.25 x .125
	1.313 to 1.375	3.2	.313 x .156	.313 x .156
	1.438 to 1.75	3.0	.375 x .188	.375 x .188
3020	.5 to .563	3.5	.125 x .063	.125 x .063
	.625 to .875	3.4	.188 x .094	.188 x .094
	.938 to 1.25	3.3	.25 x .125	.25 x .125
	1.313 to 1.375	3.2	.313 x .156	.313 x .156
	1.438 to 1.75	3.0	.375 x .188	.375 x .188
3030	.5 to .563	9.2	.25 x .125	.25 x .125
	.625 to .875	8.9	.313 x .156	.313 x .156
	.938 to 1.25	8.6	.375 x .188	.375 x .188
	1.313 to 1.375	8.9	.313 x .156	.313 x .156
	1.438 to 1.75	8.6	.375 x .188	.375 x .188

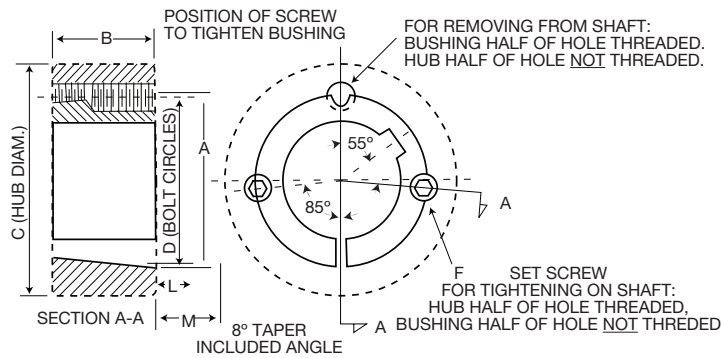
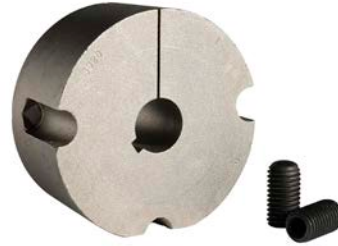

Dimensions

Bushing Number	A	B	C Ø			D	F †	L ★		M ★★	
			Class 20 Gray Iron	Class 30 Gray Iron	Steel			Standard Hex. Key	Short Key ‡	Std. Hex. Key	Short Key ‡
1008	1.386	.875	2.375	2.188	1.938	1.328	.25 x .5	1.125	.625	1.25	.75
1108	1.511	.875	2.5	2.313	2.063	1.453	.25 x .5	1.125	.625	1.25	.75
1210	1.875	1	3.625	3.25	2.875	1.75	.375 x .625	1.375	.813	1.625	1.063
1215	1.875	1.5	3.125	2.875	2.625	1.75	.375 x .625	1.375	.813	1.625	1.063
1310	2	1	3.75	3.375	3	1.875	.375 x .625	1.375	.813	1.625	1.063
1610	2.25	1	4	3.625	3.25	2.125	.375 x .625	1.375	.813	1.625	1.063
1615	2.25	1.5	3.5	3.25	3	2.125	.375 x .625	1.375	.813	1.625	1.063
2012	2.75	1.25	4.75	4.375	3.875	2.625	.438 x .875	1.563	.938	2	1.375
2517	3.375	1.75	5.5	4.875	4.375	3.25	.5 x 1	1.625	1	2.25	1.625
2525	3.375	2.5	4.75	4.5	4.25	3.25	.5 x 1	1.625	1	2.25	1.625
3020	4.25	2	7	6.25	5.625	4	.625 x 1.25	1.813	1.188	2.688	2.063
3030	4.25	3	6.25	5.75	5.375	4	.625 x 1.25	1.813	1.188	2.688	2.063

Bushings cannot be bored larger than largest bore listed.

For detail dimensions required for machining hubs, consult factory.

▼ Key furnished for these sizes only.

Ø For general reference. Severe conditions may require larger hub. Heavy well-located web may permit smaller hub. Hub diameter required depends on the particular application. Consult Martin giving full information on the proposed design. Hub diameters shown are based on 20,000, 30,000, and 50,000 P.S.I. minimum ultimate tensile strength respectively for Class 20 gray iron, Class 30 gray iron, and steel hubs.

† 2 screws required. Use in positions shown for tightening bushing on shaft. In removing bushing from shaft, remove screws and use one of them in the other hole. Bushing price includes screws.

★ Space required to tighten bushing. Also space required to loosen screws to permit removal of hub by puller.

★★ Space required to loosen bushing using one screw as jackscrew — no puller required.

‡ Standard hex key cut to minimum usable length.

No. 3535 to 5050 Bushings

Bushing Number	Bore	Weight	Bushing Keyseat	Shaft Keyseat	A	B	C Ø			D	F †	G	R
							Class 20 Gray Iron	Class 30 Gray Iron	Steel				
3535	1.188 to 1.25	14	.25 × .125	.25 × .125	5	3.5	7.75	7	6.5	4.83	.5 × 1.5	39°	▲
	1.313 to 1.375	14	.313 × .156	.313 × .156									
	1.438 to 1.75	13	.375 × .188	.375 × .188									
	1.813 to 2.25	12	.5 × .25	.5 × .25									
	2.313 to 2.75	11	.625 × .313	.625 × .313									
	2.813 to 3.25	9	.75 × .375	.75 × .375									
3.313 to 3.5	8	▼ .875 × .25	.875 × .438										
4040	1.438 to 1.75	22	.375 × .188	.375 × .188	5.75	4	9.5	8.5	7.75	5.54	.625 × 1.75	40°	▲
	1.813 to 2.25	21	.5 × .25	.5 × .25									
	2.313 to 2.75	19	.625 × .313	.625 × .313									
	2.813 to 3.25	17	.75 × .375	.75 × .375									
	3.313 to 3.625	15	.875 × .438	.875 × .438									
	3.688 to 3.75	14	.875 × .438	.875 × .438									
	3.813 to 4	13	▼ 1 × .25	1 × .5									
4545	1.938 to 2.25	30	.5 × .25	.5 × .25	6.375	4.5	10.5	9.5	8.75	6.13	.75 × 2	40°	▲
	2.313 to 2.75	28	.625 × .313	.625 × .313									
	2.813 to 3.25	26	.75 × .375	.75 × .375									
	3.313 to 3.75	23	.875 × .438	.875 × .438									
	3.813 to 4.25	20	1 × .5	1 × .5									
	4.313 to 4.5	18	▼ 1 × .25	1 × .5									
5050	2.313 to 2.75	38	.625 × .313	.625 × .313	7	5	11.5	10.5	9.5	6.72	.875 × 2.25	37°	▲
	2.813 to 3.25	35	.75 × .375	.75 × .375									
	3.313 to 3.75	32	.875 × .438	.875 × .438									
	3.813 to 4.5	27	1 × .5	1 × .5									
	4.563 to 5	24	▼ 1.25 × .438	1.25 × .625									

No. 4030 to 5040 Short Taper Bushings

Bushing Number	Bore	Weight	Bushing Keyseat	Shaft Keyseat	A	B	C Ø			D	F †	G	R
							Class 20 Gray Iron	Class 30 Gray Iron	Steel				
4030	1.438 to 1.75	24	.375 × .188	.375 × .188	5.75	3	9.5	8.5	7.75	5.54	.625 × 1.75	39°	▲
	1.813 to 2.25	21	.5 × .25	.5 × .25									
	2.313 to 2.75	20	.625 × .313	.625 × .313									
	2.813 to 3.25	18	.75 × .375	.75 × .375									
	3.313 to 3.688	15	.875 × .438	.875 × .25									
	3.75	13	▼ .875 × .25	.875 × .438									
	3.813	13	1 × .5	1 × .5									
	3.875 to 4.438	13	1 × .25	1 × .5									
4535	1.938 to 2.25	31	.5 × .25	.5 × .25	6.375	3.5	10.5	9.5	8.75	6.13	.75 × 2	40°	▲
	2.313 to 2.75	29	.625 × .313	.625 × .313									
	2.813 to 3.25	25	.75 × .375	.75 × .375									
	3.313 to 3.688	23	.875 × .438	.875 × .438									
	3.813 to 4.25	20	1 × .5	1 × .5									
	4.375 to 4.5	17	▼ 1 × .25	1 × .5									
4.75 to 4.938	15	▼ 1.25 × .25	1.25 × .625										
5040	2.438 to 2.75	40	.625 × .313	.625 × .313	7	4	11.5	10.5	9.5	6.72	.875 × 2.25	37°	▲
	2.813 to 3.25	37	.75 × .375	.75 × .375									
	3.313 to 3.75	33	.875 × .438	.875 × .438									
	3.813 to 4.5	29	1 × .5	1 × .5									
	4.75 to 5	23	▼ 1.25 × .25	1.25 × .625									

Bushings cannot be bored larger than largest bore listed.

For detail dimensions required for machining hubs, consult factory.

▼ Key furnished for these sizes only.

Ø For general reference. Severe conditions may require larger hub. Heavy well located web may permit smaller hub. Hub diameter required depends on the particular application. Consult factory giving full information on the proposed design. Hub diameters shown are based on 20,000, 30,000, and 50,000 P.S.I. minimum ultimate tensile strength respectively for Class 20 gray iron, Class 30 gray iron, and steel hubs.

† 3 screws required. Use in positions shown for tightening bushing on shaft. In

removing bushing from shaft, remove screws and use two of them in the other two holes. Bushing price includes screws. See following footnote.

▲ Provide sufficient space to tighten and loosen bushing. Width across flats of screw head is same as screw diameter which is shown in column F.

Taper Bushings Dimensions

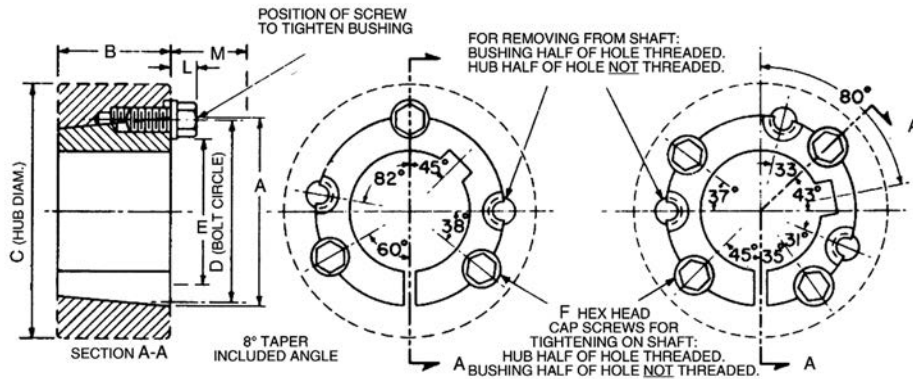
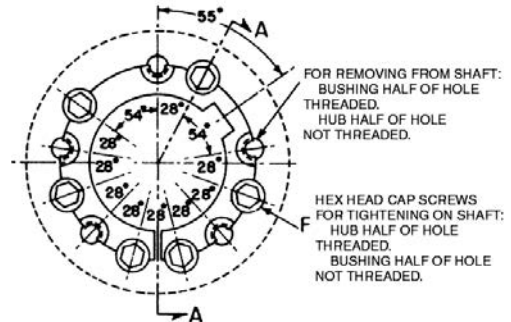
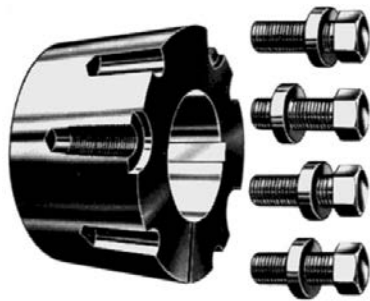

No 6050 to 120100 Taper Bushings

Bushing Number	Bore	Weight	Bushing Keyseat	Shaft Keyseat	A	B	C Ø			D	E	F †	L ★	M ★★
							Class 20 Gray Iron	Class 30 Gray Iron	Steel					
6050	3.813 to 4.5	60	1 × .5	1 × .5	9.25	5	17	15.5	13.5	9	6.75	1.25 × 3.5	1.625	4.375
	49/16 to 5.5	55	1.25 × .625	1.25 × .625										
	5.563 to 6	50	1.5 × .75	1.5 × .75										
7060	4.563 to 5.5	85	1.25 × .625	1.25 × .625	10.25	6	18.5	17	14.75	10	7.75	1.25 × 3.5	1.625	4.375
	5.563 to 6.5	75	1.5 × .75	1.5 × .75										
	6.563 to 7	65	1.75 × .75	1.75 × .75										
◊ 8065	5.063 to 5.5	120	1.25 × .625	1.25 × .625	11.25	6.5	19	17.5	15.5	11	8.75	1.25 × 3.5	1.625	4.375
	5.563 to 6.5	105	1.5 × .75	1.5 × .75										
	6.563 to 7.5	90	1.75 × .75	1.75 × .75										
	7.563 to 8	75	2 × .75	2 × .75										
◊ 10085	6.563 to 7.5	260	1.75 × .75	1.75 × .75	14.75	8.5	23.5	22	19.5	14.5	11.75	1.5 × 4.25	2	5.375
	7.563 to 9	230	2 × .75	2 × .75										
	9.063 to 10	190	2.5 × .875	2.5 × .875										
◊ 120100	7.563 to 9	410	2 × .75	2 × .75	17.25	10	28	26	23	17	14.25	1.5 × 4.25	2	5.375
	9.063 to 11	360	2.5 × .875	2.5 × .875										
	11.063 to 12	290	3 × 1	3 × 1										

Bushings cannot be bored larger than largest bore listed.

For detail dimensions required for machining hubs, consult Martin.

◊ For general reference. Severe conditions may require larger hub. Heavy well located web may permit smaller hub. Hub diameter required depends on the particular application. Consult Martin giving full information on the proposed design. Hub diameters shown are based on 20,000, 30,000, and 50,000 P.S.I. minimum ultimate tensile strength respectively for Class 20 gray iron, Class 30 gray iron, and steel hubs.

† 3 screws for 6050; four for 7060 to 10085; six for 120100. Use in positions shown for tightening bushing on shaft. In loosening bushing, remove screws and use all except one in the other holes. Bushing price includes screws.

★ Space required to tighten bushing. Also space required to loosen screws to permit removal of hub by puller.

★★ Space required to loosen bushing using screws as jackscrews— no puller required.

◊ Not currently stocked — Available on order.

Type S

Martin taper bushed type S weld-on hubs are suitable for use in many applications such as for welding to plate steel sprockets. The outside diameters of these hubs have been reduced to a minimum. This is permissible because of the reinforcing strength of the items to which they are to be welded. Cases where the attached item is of small dimensions should be referred to Martin.

Type S weld-on hubs are made of steel, drilled, tapped, and taper bored for tapered bushings. Their small size and the convenience and advantages of taper bushed construction make them of great value on many devices for use on shafts.

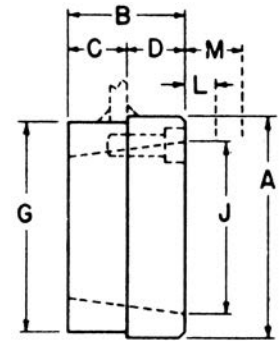

Bushing Number	For Use with Bushing Number	Max. Bore of Bushing	Weight	A	B \diamond	C $\star\star$	D ∇	G	J
S16-4	1610	1.625	.9	3	1	.275	.725	2.875 †	2.25
S16-6	1610	1.625	.9	3	1	.450	.550	2.875 †	2.25
S20-6	2012	2	1.8	3.563	1.25	.450	.800	3.438 †	2.75
S20-8	2012	2	1.4	3.563	1.25	.570	.680	3.438 †	2.75
S25-6	2517	2.5	2.6	4.25	1.75	.450	1.300	4.125 †	3.375
S25-8	2517	2.5	2.6	4.25	1.75	.565	1.185	4.125 †	3.375
S25-10	2517	2.5	2.5	4.25	1.75	.685	1.065	4.125 †	3.375
S25-16	2517	2.5	2.4	4.25	1.75	1.090	.660	4.125 †	3.375
S30-10	3020	3	4.3	5.25	2	.675	1.325	5.125 †	4.25
S30-16	3020	3	4.2	5.25	2	1.090	.910	5.125 †	4.25
S35	3535	3.5	12.8	6.5	3.5	1.160	2.340	6.375 \emptyset	5

See dimension tables on preceding page for bushing data and wrench space required.

- † + .000 - .002
- \diamond + .005 - .010
- \emptyset + .001 - .003
- ∇ + .000 - .005
- $\star\star$ + .010 - .010

Type WA

Type WA weld-on hubs are made of steel, drilled, tapped, and taper bored to receive tapered bushings. They are very useful for welding into fan rotors, pulleys, plate sprockets, impellers, agitators, and many other devices which must be firmly fastened to the shaft.

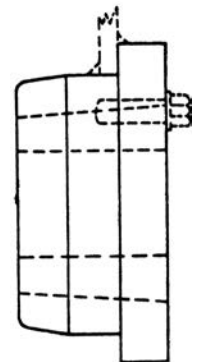

Bushing Number	For Use with Bushing Number	Max. Bore of Bushing	Weight	A	B	C	D	F	G	H	J	K
WA12	1215	1.25	1.3	2.875	1.5	.375	.625	.375	2.5 †	2.375	1.875	2.625
WA16	1615	1.625	1.5	3.25	1.5	.375	.625	.375	2.875 †	2.75	2.25	3
WA25	2517	2.5	4.0	4.875	1.75	.5	.75	.375	4.375 †	4.25	3.375	4.625
WA30	3030	3	8.6	5.5	3	.75	.75	.25	5.125 †	4.813	4.125	5
WA35	3535	3.5	15	6.75	3.5	1.25	1	.375	6.25 †	5.938	5	6
WA40	4040	4	29	7.75	4	1.5	1	.375	7.25 †	6.875	5.75	7
WA45	4545	4.5	42	8.75	4.5	1.75	1	.375	8 †	7.625	6.375	8
WA50	5050	5	57	9.5	5	1.75	1	.375	8.75 •	8.375	7	8.75
WA60	6050	6	115	13.25	5	1.75	1.25	-	12.25 \star	11.875	9.25	-
WA70	7060	7	155	14.5	6	2.25	1.25	-	13.5 \star	13.25	10.25	-
WA80	8065	8	180	15.25	6.5	2.25	1.25	-	14.25 \star	14	11.25	-
WA100	10085	10	340	19.75	8.5	3.5	1.5	-	18.75 \star	18.25	14.75	-

See dimension tables on preceding page for bushing data and wrench space required.

- † + .000 - .002
- + .000 - .003
- \star + .000 - .004

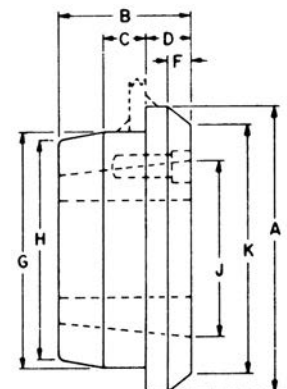

Taper Bushings Metric and Reborable



Stock Taper Bushings With Metric Bores and Keyways

★ Metric Bores	★ Metric Keyway	Taper Bushing Number			
14, 16	5 × 2.3	1008	1108	1210	
		1215	1610	1615	
18, 19 20, 22	6 × 2.8	1008	1108	1210	1215
		1610	1615	2012	2517
24	8 × 3.3	1108	1210	1215	
		1610	1615	2012	2517
25	8 × 3.3	1210	1215	1610	
		1615	2012	2517	
28, 30	8 × 3.3	1210	1215	1610	
		1615	2012	2517	3020
32	10 × 3.3	1610	1615		
		2012	2517	3020	
35	10 × 3.3	1610	1615		
		2012	2517	3020	
38	10 × 3.3	1610	1615		
		2012	2517	3020	
40, 42	12 × 3.3	2012			
		2517	3020		
45, 48	14 × 3.8	2012			
		2517	3020		
50	14 × 3.8	2517	3020		
		16 × 4.3	2517	3020	

★ Millimeter Bores and Keyways from ISO Std. R773. 1" = 25.4 millimeters

NOTE: For other metric bore sizes consult factory.

Stock Reborable Taper Bushings With No Keyways

Sintered Steel		Gray Iron		Steel		Stainless Steel	
1008	.563			1008	.5	1008	.5
1108	.5			1108	.5	1108	
1210	.563			1210	.5	1210	.5
1215	.5			1215	.5	1215	
1310	.5			1310		1310	
1610	.5 1.313			1610	.5	1610	.5
1615	.5 1.313			1615	.5	1615	
2012	.5			2012	.5	2012	.5
2517	.5 1.563			2517	.5	2517	.5
		2525	2.125	2525		2525	
3020	.938 1.688	3020	.938 1.438 2.938	3020	.938	3020	.938
		3030	.938 2.438 2.938	3030		3030	
		3535	1.188 2.438 2.938	3535		3535	
		4040	1.438 3.438 3.938	4040		4040	
		4545	3.938 4.438	4545		4545	
		5050	2.438 3.938				
		6050	3.438 5.438				
		7060	3.938				
		8065	4.438				
		10085	7				
		H120100	8				

★ Not currently stocked. Consult factory for availability and pricing.