

*2-3 Pitch Lead Length

TAPTITE® II THREAD ROLLING SCREWS						Reminc	
Nominal Screw Width	C		D		G		
	Screw Body Dimensions					Point	
	Diameter of Circumscribing Circle		Measurement Across Center		Diameter of Circumscribing Circle		
	Max	Min	Max	Min	Max		
2-56	.0875	.0835	.0840	.0800	.070		
3-48	.1010	.0970	.0970	.0930	.081		
4-40	.1145	.1105	.1095	.1055	.090		
5-40	.1275	.1235	.1225	.1185	.103		
6-32	.1410	.1350	.1350	.1290	.111		
8-32	.1670	.1610	.1610	.1550	.137		
10-24	.1940	.1880	.1860	.1800	.153		
10-32	.1930	.1870	.1870	.1810	.163		
12-24	.2200	.2140	.2120	.2060	.179		
1/4-20	.2550	.2490	.2450	.2390	.206		
5/16-18	.3180	.3120	.307	.301	.264		
3/8-16	.3810	.3750	.3685	.3625	.320		
1/2-13	.5075	.5015	.4920	.4860	.432		
Tolerance on Length	Nominal Screw Size	Nominal Screw Length					
		To 1/2" Incl.	Over 1/2" to 1" Incl.	Over 1" to 2" Incl.	Over 2"		
	#2 - #12	+0, -.020	+0, -.030	+0, -.060	+0, -.090		
1/4" - 1/2"	+0, -.030	+0, -.030	+0, -.060	+0, -.090			
Description	Trilobular thread rolling screw. As each lobe of the screw moves through the pilot hole in the nut material, it forms and work-hardens the nut thread metal, producing an uninterrupted grain flow.						
Applications/ Advantages	For drilled, punched or corrod holes in all ductile metals and punch extruded metals. Eliminates chips, requires low drive torque and provides excellent resistance to vibrational loosening.						
Material	Steel			Stainless			
	Steel thread rolling screws shall be made from cold-heading steel conforming to the following chemical composition: Carbon: 0.13-0.27%; Manganese: 0.64-1.71%			18-8: 18-8 stainless steel 410: 410 austenitic stainless steel			
Heat Treatment	Screws shall be quenched in liquid and then tempered by reheating to 650°F minimum.			410: Screws shall be annealed by heating to 1850° - 1950°F, held at least for 1/2 hr & rapid air- or oil-quenched; then reheated to 525°F min. for at least 1 hr & air cooled to provide the required mechanical properties.			
Case Hardness	Rockwell C45 minimum			-			
Case Depth	2-56 through 6-32 diameters: .002 - .007 8-32 through 12-24 diameters: .004 - .009 1/4-20 diameter & larger: .005 - .011			-			
Core Hardness (after tempering)	Rockwell C28-38			18-8: Rockwell B90 - C20 410: Rockwell C34 - 42			
Plating	See Appendix-A for information on the plating of Taptite® II screws.			Stainless thread rolling screws are supplied passivated and waxed.			

TAPTITE® II RECOMMENDED PILOT HOLE SIZES FOR VARIOUS MATERIAL THICKNESSES															Reminc
Application Duty Class	Light 0.3 Diameter of Material			Medium-Light 0.5 Diameter of Material			Medium-Heavy 0.75 Diameter of Material			Full Strength 1.0 Diameter of Material			Extended 1.25 Diameter of Material		
% of Thread	90%			85%			80%			75%			70%		
Nominal Size	Material Thickness	Pilot Hole	Drill Size	Material Thickness	Pilot Hole	Drill Size	Material Thickness	Pilot Hole	Drill Size	Material Thickness	Pilot Hole	Drill Size	Material Thickness	Pilot Hole	Drill Size
2-56	.017-.034	.0756	.0748	.034-.052	.0761	.076	.052-.073	.0767	.0763	.073-.095	.0773	.0781	.095-.169	.0779	.0781
3-48	.020-.040	.0868	.0866	.040-.059	.0875	.0866	.059-.084	.0882	.089	.084-.110	.0888	.089	.110-.141	.0895	.089
4-40	.022-.045	.0974	.098	.045-.067	.0982	.098	.067-.095	.099	.0995	.095-.126	.0998	.0995	.126-.157	.1006	.0995
5-40	.025-.051	.1104	.1102	.051-.075	.1112	.111	.075-.106	.112	.113	.106-.141	.1128	.113	.141-.175	.1136	.113
6-32	.028-.066	.1197	.120	.066-.083	.1207	.120	.083-.117	.1218	.122	.117-.152	.1228	.122	.152-.193	.1238	.125
8-32	.033-.066	.1457	.1457	.066-.098	.1467	.147	.098-.141	.1478	.1476	.141-.180	.1488	.1496	.180-.230	.1498	.1496
10-24	.038-.079	.1656	.166	.079-.114	.167	.1673	.114-.162	.1683	.1695	.162-.209	.1697	.1695	.209-.266	.171	.1719
10-32	.038-.079	.1717	.1719	.079-.114	.1727	.173	.114-.162	.1738	.173	.162-.209	.1748	.1732	.209-.266	.1758	.177
12-24	.043-.086	.1916	.191	.086-.130	.193	.1929	.130-.184	.1943	.196	.184-.238	.1957	.196	.238-.302	.197	.1969
1/4-20	.050-.100	.2208	.221	.100-.150	.2224	.2244	.150-.213	.224	.2244	.213-.275	.2256	.2264	.275-.350	.2273	.228
5/16-18	.062-.126	.2800	.2795	.126-.188	.2818	.2812	.188-.266	.2836	.2835	.266-.345	.2854	.2854	.345-.438	.2872	.2874
3/8-16	.075-.150	.3384	.3386	.150-.225	.3405	.3386	.225-.319	.3425	.3425	.319-.413	.3445	.3455	.413-.525	.3466	.3465
1/2-13	.100-.200	.455	.4531	.200-.300	.4575	.4531	.300-.425	.460	.4531	.425-.550	.4625	.4688	.550-.700	.465	.4688

NOTES:

APPLICATION DUTY CLASS is a general term used here to group material thicknesses in terms of screw diameters. For example, the average material thickness listed under "Medium-Heavy" equals 75% of the screw diameter.

TAPTITE® II SUGGESTED HOLE SIZES AT VARIOUS PERCENTAGES OF THREAD ENGAGEMENT															Reminc
Nominal Screw Size	Percent Thread														
	100	95	90 ⁽¹⁾	85 ⁽¹⁾	80	75	70	65	60	55	50	45	40	35	
	Pilot Hole Sizes														
2-56	.0744	.0750	.0756	.0761	.0767	.0773	.0779	.0785	.0790	.0796	.0802	.0808	.0814	.0819	
3-48	.0855	.0861	.0868	.0875	.0882	.0888	.0895	.0902	.0909	.0916	.0922	.0929	.0936	.0943	
4-40	.0958	.0966	.0974	.0982	.0990	.0998	.1006	.1014	.1023	.1031	.1039	.1047	.1055	.1063	
5-40	.1088	.1096	.1104	.1112	.1120	.1128	.1136	.1144	.1153	.1161	.1169	.1177	.1185	.1193	
6-32	.1177	.1187	.1197	.1207	.1218	.1228	.1238	.1248	.1258	.1268	.1278	.1289	.1299	.1309	
8-32	.1437	.1447	.1457	.1467	.1478	.1488	.1498	.1508	.1518	.1528	.1538	.1549	.1559	.1569	
10-24	.1629	.1643	.1656	.1670	.1683	.1697	.1710	.1724	.1738	.1751	.1765	.1778	.1792	.1805	
10-32	.1697	.1707	.1717	.1727	.1738	.1748	.1758	.1768	.1778	.1788	.1798	.1809	.1819	.1829	
12-24	.1889	.1903	.1916	.1930	.1943	.1957	.1970	.1984	.1998	.2011	.2025	.2038	.2052	.2065	
1/4-20	.2175	.2191	.2208	.2224	.2240	.2256	.2273	.2289	.2305	.2321	.2338	.2354	.2370	.2386	
5/16-18	.2764	.2782	.2800	.2818	.2836	.2854	.2872	.2890	.2908	.2926	.2944	.2963	.2981	.2999	
3/8-16	.3344	.3364	.3384	.3405	.3425	.3445	.3466	.3486	.3506	.3527	.3547	.3567	.3588	.3608	
1/2-13	.4500	.4525	.4550	.4575	.4600	.4625	.4650	.4675	.4700	.4725	.4750	.4775	.4800	.4825	

(1) Pilot holes listed under 90% & 85% (thread percent) also recommended for single punch extruded holes. See suggested extruded hole chart.

NOTES:

-The above values are based on a linear relation between hole size and percentage thread engagement, the hole data becomes less accurate for engagements less than 70%. The chart indicates that a 10-32 screw in a .1738" hole size provides 80% thread engagement.

-These holes are based on the U.S. basic thread depth of .6495 times the pitch and are calculated using nominal screw diameters.

©Taptite II is a registered trademark of REMINC (Research Engineering & Manufacturing Inc.)

www.mutualscrew.com

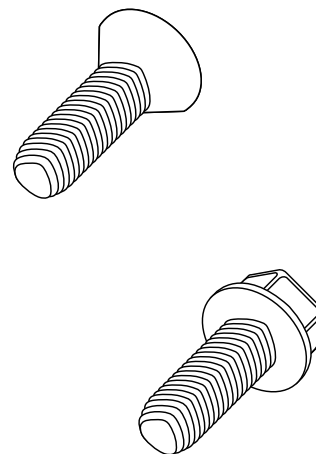
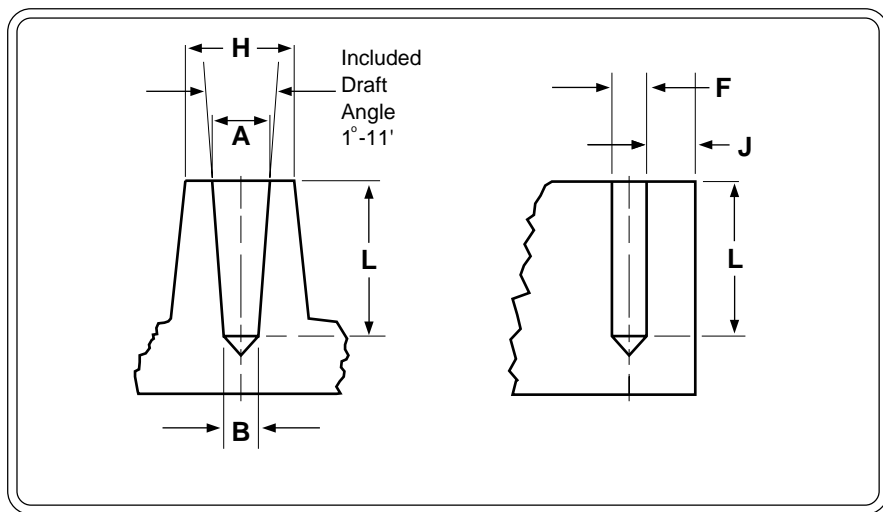

TAPTITE® II SUGGESTED HOLE SIZES FOR ALUMINUM OR ZINC DIE CASTING								Reminc
Screw Size	A		B		F Hole Diameter as Drilled	L Length of Thread Engagement	H Boss Diameter	J Distance to Edge for No Measurable Distortion
	Top		Bottom					
	Hole Diameter as Cast Std. Taper							
	Max	Min	Max	Min				
2-56	.081	.078	.077	.074	.077	.172	.197	.046
3-48	.093	.090	.088	.085	.088	.198	.208	.054
4-40	.105	.102	.099	.096	.099	.224	.220	.065
5-40	.118	.115	.112	.109	.112	.250	.232	.065
6-32	.128	.125	.122	.119	.122	.276	.242	.081
8-32	.155	.152	.148	.145	.148	.328	.272	.081
10-24	.177	.174	.168	.165	.168	.380	.315	.108
10-32	.182	.179	.174	.171	.174	.380	.315	.081
12-24	.203	.200	.194	.191	.194	.432	.359	.108
1/4-20	.235	.232	.224	.221	.224	.500	.415	.130
5/16-18	.297	.294	.284	.281	.284	.625	.519	.144
3/8-16	.359	.356	.343	.340	.343	.750	.623	.162
1/2-13	.481	.478	.460	.457	.460	1.000	.830	.200

NOTES:

-The minimum length of thread engagement should be equal to twice the diameter of the screw (to approach utilizing available screw strength). The hole diameter, to ensure optimum performance, should provide for 65% to 75% thread engagement.

©Taptite II is a registered trademark of REMINC (Research Engineering & Manufacturing Inc.)

www.mutualscrew.com

Contact: 800.222.0324 / 201.845.5700

Email ID: bill@mutualscrew.com

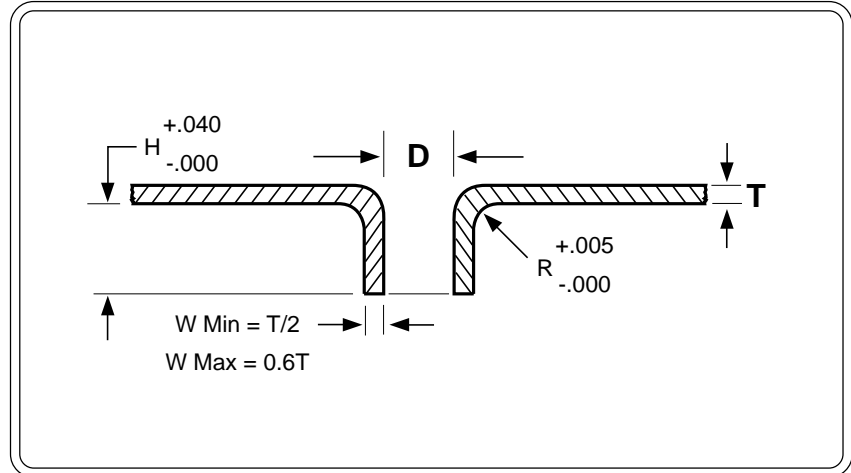
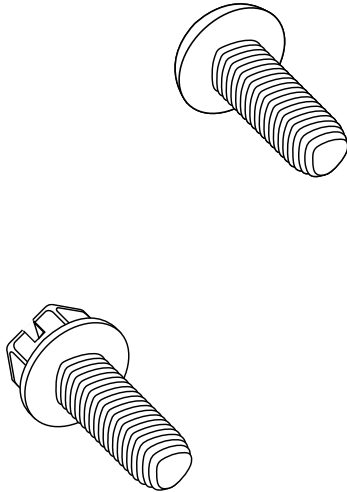

TAPTITE® II SUGGESTED EXTRUDED HOLES IN LIGHT-GAUGE STEEL													Reminc	
Inch Thickness T	.02	.03	.04	.06	.09	.13	.16	.19	.22	.25	.31	.38		
Screw Size	Hole Sizes - D												D H O L E D I A M E T E R	
6-32	.118 .120	.118 .121	.119 .122	.120 .123	.122 .125	-	-	-	-	-	-	-		-
8-32	.144 .146	.144 .147	.145 .148	.146 .149	.147 .150	.148 .152	-	-	-	-	-	-		-
10-24	.163 .165	.163 .166	.164 .167	.165 .168	.166 .170	.168 .173	-	-	-	-	-	-		-
10-32	.170 .172	.170 .173	.171 .174	.172 .175	.173 .176	.174 .177	-	-	-	-	-	-		-
12-24	.189 .191	.189 .192	.190 .193	.191 .194	.192 .196	.193 .197	.195 .200	.198 .203	-	-	-	-		-
1/4-20	-	-	.218 .220	.218 .221	.219 .223	.221 .225	.224 .228	.227 .231	.228 .233	.230 .235	-	-		-
5/16-18	-	-	-	.277 .279	.278 .280	.279 .281	.280 .283	.281 .285	.283 .288	.285 .290	-	-		-
3/8-16	-	-	-	-	-	.335 .337	.336 .338	.337 .340	.337 .340	.342 .346	.344 .349	-		-
1/2-13	-	-	-	-	-	-	-	.450 .453	.452 .455	.454 .457	.455 .460	.459 .464		-

NOTES:

Taptite® II screws will develop almost twice the failure torque in extruded holes, providing maximum joint integrity.

The above chart indicates that an extruded hole diameter of .166" to .170" is suggested in .090" thick material when using a 10-24 Taptite® II screw.

®Taptite II is a registered trademark of REMINC (Research Engineering & Manufacturing Inc.)

TAPTITE® II TYPICAL TORQUE PERFORMANCE IN COLD ROLLED STEEL							Reminc
Screw Size	Plate Thickness	Hole Size	Nearest Drill Size	Thread Forming Torque	Prevailing First Removal Torque	Recommended Assembly Torque	Failure Torque
2-56	.0469	.075	1.9mm	1-2	.5-1	4	6-7*
	.0625	.076	#48	1-2	.5-1	4	8-10*
	.0938	.079	#47	1-2	.5-1	5	11-14*
3-48	.0625	.087	2.2mm	3-4	1-2	6	14-15*
	.0938	.089	#43	3-5	1-2	7	15-16*
	.1250	.090	#43	4-6	1-2	7	15-18*
4-40	.0312	.098	#40	2-3	1-2	6	8-11*
	.0625	.102	2.6mm	3-4	1-2	9	15-18*
	.0938	.102	2.6mm	3-4	1-2	11	22-27*
5-40	.0625	.111	#34	4-5	2-3	12	22-29*
	.0938	.113	#33	4-7	3-4	18	34-41*
	.1250	.116	#32	6-8	4-5	20	38-46*
6-32	.0625	.120	#31	4-7	3-4	14	25-30*
	.0938	.120	#31	6-9	3-5	20	35-45*
	.1250	.125	1/8	6-9	4-6	22	39-45*
8-32	.0938	.147	#26	10-13	5-7	30	65-75*
	.1250	.150	3.8mm	11-14	4-7	45	75-85*
	.1875	.150	3.8mm	16-20	8-11	45	75-95*
10-24	.0938	.172	11/64	14-18	5-8	35	65-80*
	.1250	.172	11/64	14-18	5-8	45	80-90*
	.1875	.172	11/64	17-22	9-13	55	100-115*
10-32	.0938	.173	#17	11-14	9-13	35	80-95*
	.1250	.177	#16	12-16	9-13	50	100-120*
	.1875	.177	#16	19-25	12-16	70	115-140*
12-24	.1250	.196	#9	19-24	9-12	65	95-115*
	.1875	.199	#8	21-26	9-13	75	135-155*
	.2500	.203	13/64	21-26	10-14	85	150-170*
1/4-20	.1250	.224	5.7mm	30-36	18-25	85	170-195*
	.1875	.224	5.7mm	45-55	25-35	125	205-235*
	.2500	.228	#1	55-65	25-35	125	205-235*
5/16-18	.1875	.281	K	75-85	40-50	160	380-410*
	.2500	.285	7.25mm	75-85	40-50	225	425-465*
	.3125	.285	7.25mm	80-90	55-65	250	450-500*
3/8-16	.2500	.348	S	90-100	45-55	350	825-875*
	.3125	.348	S	110-125	50-60	400	950-1000*
	.3750	.354	9mm	95-110	30-45	450	950-1000*
1/2-13	.250	.465	29/64	150-180	60-80	500	975-1075*
	.3750	.469	15/32	185-215	60-90	850	1600-1800*
	.5000	.469	15/32	235-275	75-105	1000	1900-2200*

*Indicates probability that nut threads will strip.

*Indicates probability that screw will break.

NOTES: •Torque values are listed in pound-inches. Plate dimensions are listed in inches.

•Torque values were developed using hex washer head screws, zinc plated plus wax, driven at low speed under laboratory controlled conditions. The values shown only represent these controlled conditions and should not be used in lieu of proper application testing. The data is presented to provide the user with an estimate of what could be achieved in an actual application having a thicker or thinner nut member, harder or softer material, different hole or fastener all contribute to variations in torque performance.

•Recommended tightening torque is intended to induce approximately 30,000 to 50,000 psi clamping force.

•Prevailing first removal torque, the torque necessary to remove the screw after the head has been unseated, is an indication of Taptite® II screws' inherent resistance to loosening under vibration, even without the screw head being seated.

®Taptite II is a registered trademark of REMINC (Research Engineering & Manufacturing Inc.)

www.mutualscrew.com

Contact: 800.222.0324 / 201.845.5700

Email ID: bill@mutualscrew.com