



Mini Machines Direct
MMD

TASKMASTER



Product
Guide

www.minimachinesdirect.com.au



• Ph. 1300 449 844

- Email: office@minimachinesdirect.com.au
- Website: www.minimachinesdirect.com.au

Thank you for ordering your FREE Product Guide. As promised, you will discover more about...

“Efficient and Reliable Multi-Functional TASKMASTER Earthmoving Machines and Attachments.”

TASKMASTER

Hi! It's Craig Emerson of Mini Machines Direct.

We're all about working with you to tailor the best **MACHINE, TRAILER and ATTACHMENTS PACKAGE** for you!

How do we do that? In lots of ways!

- Our Machines are designed to go where other larger machines cannot. With outstanding manoeuvrability in confined spaces due to their zero-turn-capacity, they are perfect for levelling, digging and other tasks and projects in tight areas.
- Our Mini Skid Steer Loaders, Excavators, and Attachments fit onto the back of a standard sized trailer. It is just a simple process of loading and unloading them. Logistics problems solved.

*All the best
Craig and the team
Mini Machines Direct*

“One Taskmaster For A Range Of Tasks.”

P.S. If you're after a proven way to beat the high cost of quality Earthmoving Machines for your business without sacrificing quality, please contact us ASAP so you do not miss out.

“About Mini Machines Direct”

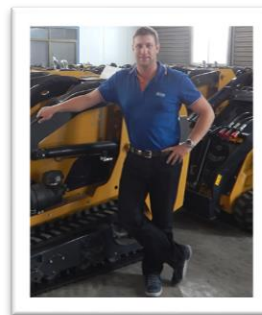

Hi, my name is Craig Emerson, the owner of Mini Machines Direct.

With 20 years of experience in heavy construction and mining machinery maintenance, I have the know-how in dealing with heavy duty machinery doing diagnosing, repairs, and rebuilding as a diesel fitter.

Over those years I have worked at dealerships, quarries, mines and construction sites.

With the help of my wife and twin daughters, I decided that after many years it was time to step out of the technician role and to start being a business owner, **which is why I started Mini Machines Direct.**

I know and understand firsthand that when quality components and parts are used, longevity can be achieved out of the machinery, and that reliable machinery can be the backbone of any earth moving business.

I've always been an admirer of the versatility of mini skid steers; they are just top-notch machines. There is so much potential in them that I wanted to start my own business selling top-notch mini skid steers to companies and people across Australia.

Of course, there's a lot more to our story than this, which we look forward to sharing with you when you contact us for further information.

For further information and exact pricing on our Mini Skid Steer Loaders, please contact us on **1300 449 844**

Email us at office@minimachinesdirect.com.au

Website www.minimachinesdirect.com.au



10 BENEFITS OF MINI MACHINES DIRECT

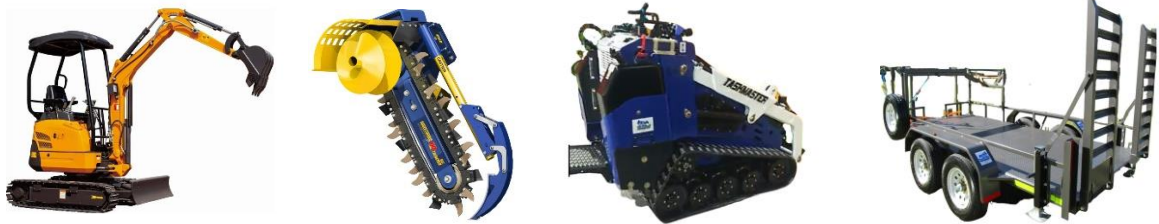

At Mini Machines Direct, we have a wealth of personal experience in providing businesses with great value Earthmoving and Construction Equipment from our Taskmaster range. We are friendly professionals who stand behind the products that we sell. And while there are many reasons for you to choose us for your MINI SKID STEER, EXCAVATOR, SKID STEER, TRAILER, AND ATTACHMENTS, here are just ten of them:

1. **Professional Industry Knowledge.** We have many years of experience over a variety of roles and industries related to the servicing and maintenance of earthmoving and mining machinery. When you deal with us, you know that you are dealing with a team of professionals who understand the products like the backs of their hands and will work extensively with you to get you exactly what you need. We can give recommendations based on product types, order sizes and everything in between that you might want a helping hand with.
2. **Quality Big brand Components.** Our Machines are thoroughly tried and tested and have been used by our customers and ourselves extensively. We spec our Machines with well-known International Quality Parts. We Stand are proud to stand behind our Machines. All our products are compliant with International Standards ISO 9001.
3. **Easy to Service.** Our range of Taskmaster Machines are designed to be easy to maintain and service. Hinged, lockable enclosure doors that grants access to all serviceable parts for inspection and service. This accessibility makes the day-to-day servicing easy and ensures a longer lifespan for your Assets.
4. **Easy to Use & Operate.** If you have never operated Earth Moving Equipment, learning to operate one is not difficult. Most machines have simple Joystick Controls. Intuitive controls mean that almost anyone can use this piece of equipment and start putting it to work immediately. All machines come with Operators and Safety Manuals.
5. **Return on Investment.** Labor costs can be set aside for an efficient, easy to maintain, and with long lasting service. Which means you will be turning a profit with your new Taskmaster Mini Skid Steer Loader, Excavator, or Skid Steer in no time. Speaking of time, the amount you will save by sending in the Machine to do the job in a precise, efficient manner is also going to help you to maximize returns in the long run.
6. **Standard Inclusions.** Our Mini Skid Steer Loaders come standard with a 4 in 1 Bucket - Doze, Load, Dump, Grab. Extra Counterweights for additional capacity. Set of service Filters. Waterproof Operators Manual Holder. Where other brands may charge additional fees for such options.
7. **Versatility.** Our machines are genuinely a jack-of-all-trades on any job site. From Augers, Standard Bucket, 4 in 1 Bucket, Pallet Forks and more. Mini Machines Direct can supply a range Attachments and Trailers. All you can think of to handle a variety of different tasks with ease.
8. **Tracked or Wheeled Options.** Machines are available in both Tracked and Wheeled options. Tracks provide better traction in sandy, wet, muddy ground. They have less ground pressure, meaning they are less likely to damage turf and soft ground. Wheels are often better for hard surfaces like concrete. Generally, have faster travel speed and can maneuver in tighter spaces due to the shorter wheelbase.
9. **Diesel and Petrol Engine Options.** Diesel engines will get you further in the long run. Generally, they have more torque much as a petrol engine would. Petrol Engines however have come along way in recent years and are getting popular. Services regularly both will provide great service life.
10. **Auger Torque & Digga Attachment Dealer** – We have you covered when it comes to attachments. We are an authorised Auger Torque and Digga Attachment dealer, so we have got all your needs covered with variety, selection, function and budget all taken care of when choosing Attachments.

For further information and exact pricing on our Mini Skid Steer Loaders, please contact us on **1300 449 844**

Email us at office@minimachinesdirect.com.au

Website www.minimachinesdirect.com.au



PRODUCTS IN THIS GUIDE

E Guide - Click on the Item Below to take you to each section

Mini Skid Steer Loader

- [TM14S](#) – Petrol 14hp – wheel – manual joystick control **P 5**
- [TM23W](#) – Petrol 23hp – wheel – manual joystick control **P 8**
- [TM23T](#) – Petrol 23hp – track – manual joystick control **P 11**
- [TM30W](#) – Diesel 30hp – wheel – pilot joystick control **P 14**
- [TM30T](#) – Diesel 30hp – track – pilot joystick control **P 17**
- [ML50T](#) – Diesel 50hp – track – pilot joystick control **P 20**

Skid Steer Loader

- [TM60WR](#) – Diesel 60hp – wheel – pilot joystick control – radial lift **P 23**
- [TM75WR](#) – Diesel 75hp – wheel – pilot joystick control – radial lift **P 26**
- [TM95WV](#) – Diesel 95hp – wheel – pilot joystick control – vertical lift **P 29**

Excavator

- [TM 1.0](#) – Diesel – track – manual joystick control **P 32**
- [TM 1.7](#) – Diesel – track – manual joystick control **P 35**
- [TM 1.8](#) – Diesel – track – pilot joystick control **P 38**
- [TM 2.0](#) – Diesel – track – pilot joystick control **P 42**
– swing boom – expanding tracks

Trailers

- [Plant Trailer](#) – *If it is not here, ask us!* **P 46**
- [Brake Controller Bluetooth](#) **P 49**

Attachments

P50

[Trencher](#) – [Auger Drive](#) – [Augers](#) - [Pallet Forks](#) – [Bucket](#) – [Quick Hitch](#)

If it is not here, ask us!

For further information and exact pricing on our Mini Skid Steer Loaders, please contact us on **1300 449 844**

Email us at office@minimachinesdirect.com.au

Website www.minimachinesdirect.com.au



TM14S

Micro Skid Steer Loader – 14hp Briggs and Stratton Petrol Engine

Only 740mm Wide – Designed for Narrow Access!



TASKMASTER

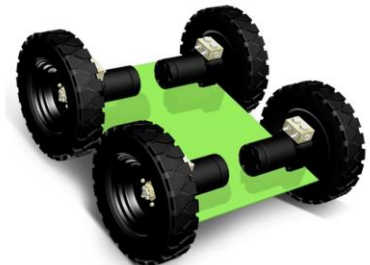

\$ 19,000 including GST

Includes 4/1 Bucket!! (Optional Teeth)

* RRP above includes GST Contact us for latest pricing *

For further information and exact pricing on our Mini Skid Steer Loaders, please contact us on 1300 449 844

Email us at office@minimachinesdirect.com.au

Website www.minimachinesdirect.com.au



TM14S - STANDARD FEATURES

- **740mm Wide** – Will fit through Internal Door
- **Solid Tires** – Puncher Proof and Stable
- **4 Drive Motors** – No Chains to Adjust, Faster Travel, Tighter Turning
- **4 in 1 Bucket** – Doze, Dig, Dump, Carry, Clamp, Grab, Optional Teeth
- **Leveling Valve** – Keeps Bucket Level when Raising the Arm
- **Joystick Steering Control** – Manual
- **Large Alloy Radiator with Cooling Fan** – Efficient Cooling of Engine and Hydraulic Oil
- **Curved Lift Arms to Facilitate a Radial Lift Pattern** – Allows Attachments to Lift 'Up' and 'Out' Increasing Clearance to the Front of the Machine. Handy When Using Large Augers
- **Hydraulic Oil Cooler** – Keeps Oil Temperature in Check
- **Auxiliary Hydraulic Outputs** – Operate Many Work Tools
- **Hose Quick Coupler Fittings** – Italian Made Illuminates Dirt Entry and Leakage
- **CNC Manufacturing and Electrophoresis Paint Process** – For Rust Protection and an Excellent Finish
- **Large Donaldson Air Cleaner Primary/Secondary with Dust Venturi** – Longer Service Intervals (Optional Clogging Indicator)
- **Hydrostatic Drive Train System** – Benefits of Hydraulic Power
- **Muffler Insulation** – Reduces Under Bonnet Temperature
- **Counterweights** – Increases capacity
- **Standard Attachment Mounting Plate** – Fits Most Common Attachments
- **Operator Platform Suspension** – Provides Great Visibility and Operator Comfort
- **Gauges and Warning Lights** – Machine Protection
- **Engine Access Panel Hinged and Lockable** – Allows Easy Access to All Major Components for Inspection and Servicing
- **Heat-Treated Pins and Greaseable Bronze Bushes** – For Longer Life
- **Tie Down Locations** – Safe Security for Transporting
- **Lift Hook Locations** – Safe Lifting of Machine
- **Key Locks on Access Panels and Fuel Caps** – For Security
- **Service Kit and Tools** – Maintenance items
- **Emergency Stop Switch** – Operator safety
- **Operators Manual** – Waterproof Holder for Safety and Protection
- **Reverse Stop Panel** – Operator Safety
- **LED Lights** – Day and Night Vision



For further information and exact pricing on our Mini Skid Steer Loaders, please contact us on **1300 449 844**

Email us at office@minimachinesdirect.com.au

Website www.minimachinesdirect.com.au



SPECIFICATIONS

ENGINE

Engine Make	Briggs and Stratton XR2100 (USA)
Fuel Type	Petrol
Rated Power	14 hp (10.4 kw)
Electrical	12 Volt / Alternator

HYDRAULIC SYSTEM

Pump Brand	Permco (USA)
Valve brand	Hydro Control Joystick (Italian)
Pressure	2610 PSI (180 Bar)
Flow	21 L/Min
Cooler	Alloy Cooling Radiator

DRIVING SYSTEM

Motor Brand	Danfoss (Danish)
Pressure	2610 PSI (180 Bar)
Flow	21 L/Min
Speed	6.8 Km/h

AUX CIRCUIT

Valve Brand	Trinity Flat Faced Couplers (Italian)
Pressure	2610 PSI (Bar)
Flow	21 L/Min

FLUID CAPACITIES

Fuel	6.6 L Petrol
Hydraulic Oil	L
Engine Oil	L
Coolant	

RATED LOAD

50% of Tip Capacity	150 kg (Optional Counterweights)
35% of Tip Capacity	100 kg (Optional Counterweights)
	See Our Lift Demo Videos! -Will Lift 300kg @ 600mm

DIMENSIONS

Height to Bucket Hinge Pin	1850 mm
Width	740 mm
Weight	650 kg
Height Max	2450 mm
Height Min	1390 mm
Length with Bucket	2150 mm
Length without Bucket	1650 mm
Wheelbase	600 mm
Ground Clearance	135 mm
Angle of Departure	18 deg



For further information and exact pricing on our Mini Skid Steer Loaders, please contact us on **1300 449 844**

Email us at office@minimachinesdirect.com.au

Website www.minimachinesdirect.com.au



TM23W

Mini Skid Steer Loader - Wheel Drive – 23hp Briggs and Stratton Or Honda Petrol Engine

*** Ask us about Optional Pilot / Servo Control System ***

TASKMASTER



\$ 26,600 including GST

Includes 4/1 Bucket!! (Optional Teeth)

* RRP above includes GST Contact us for latest pricing *

For further information and exact pricing on our Mini Skid Steer Loaders, please contact us on **1300 449 844**

Email us at office@minimachinesdirect.com.au

Website www.minimachinesdirect.com.au



TM23W - STANDARD FEATURES

- **4 in 1 Bucket** – Doze, Dig, Dump, Carry, Clamp, Grab, Optional Teeth
- **4 Drive Motors** – No Chains to Adjust, Faster Travel Speed, and Tighter Turning due to Shorter Wheelbase.
- **Leveling Valve** – Keeps the Bucket Level When Raising the Arm
- **Joystick Steering Control** – Manual (pilot operated optional)
- **Large Alloy Radiator with Cooling Fan** – Efficient Cooling of Engine and Hydraulic Oil
- **Curved Lift Arms to Facilitate a Radial Lift Pattern** – Allows Attachments to Lift 'Up' and 'Out' Increasing Clearance to the Front of the Machine. Handy When Using Large Augers
- **Hydraulic Oil Cooler** – Keeps Oil Temperature in Check
- **Auxiliary Hydraulic Outputs** – Operate Many Work Tools
- **Hose Quick Coupler Fittings** – Italian Made Illuminates Dirt Entry and Leakage
- **CNC Manufacturing and Electrophoresis Paint Process** – For Rust Protection and an Excellent Finish
- **Large Donaldson Air Cleaner Primary/Secondary with Dust Venturi** – Longer Service Intervals (Optional Clogging Indicator)
- **Hydrostatic Drive Train System** – Benefits of Hydraulic Power
- **Muffler Insulation** – Reduces Under Bonnet Temperature
- **Counterweights** – Increases Capacity
- **Standard Attachment Mounting Plate** – Fits Most Common Attachments
- **Operator Platform Suspension** – Provides Great Visibility and Operator Comfort
- **Gauges and Warning Lights** – Machine Protection
- **Engine Access Panel Hinged and Lockable** – Allows Easy Access to All Major Components for Inspection and Servicing
- **Hose Protection** – Abrasion Resistance for Longer Life
- **Heat-Treated Pins and Greaseable Bronze Bushes** – For Longer Life
- **Counterweights** – Increases Capacity
- **Tie Down Locations** – Safe Security for Transporting
- **Lift Hook Locations** – Safe Lifting of Machine
- **Key Locks on Access Panels and Fuel Caps** – For Security
- **Service Kit and Tools** – Maintenance items
- **Emergency Stop Switch** – Operator Safety
- **Operators Manual** – Waterproof Holder for Safety and Protection
- **Reverse Stop Panel** – Operator Safety
- **LED Lights** – Day and Night Vision



For further information and exact pricing on our Mini Skid Steer Loaders, please contact us on **1300 449 844**

Email us at office@minimachinesdirect.com.au

Website www.minimachinesdirect.com.au



SPECIFICATIONS

ENGINE

Engine Make	Briggs and Stratton Vanguard 'V' Twin (USA) Or Honda
Fuel Type	Petrol
Rated Power	23 hp (17.1 kw)
Electrical	12 Volt / Alternator

HYDRAULIC SYSTEM

Pump Brand	Permco (USA)
Valve brand	Hydro Control Joystick (Italian)
Pressure	2610 PSI (180 Bar)
Flow	58 L/Min
Cooler	Alloy Cooling Radiator

DRIVING SYSTEM

Motor Brand	Danfoss (Danish)
Pressure	2610 PSI (180 Bar)
Flow	58 L/Min
Speed	6 Km/h

AUX CIRCUIT

Valve Brand	Trinity Flat Faced Couplers (Italian)
Pressure	2610 PSI (180 Bar)
Flow	58 L/Min

FLUID CAPACITIES

Fuel	23 L Petrol
Hydraulic Oil	30 L
Engine Oil	1.5 L
Coolant	

RATED LOAD

50% of Tip Capacity	200 kg (Optional Counterweight)
35% of Tip Capacity	140 kg (Optional Counterweight)
	See Our Lift Demo Videos! -Will Lift 400kg @ 600mm

DIMENSIONS

Height to Bucket Hinge Pin	1914 mm
Width	1150 mm
Weight	800 kg
Height Max	2452 mm
Height Min	1370 mm
Length with Bucket	2170 mm
Length without Bucket	1740 mm
Wheelbase	657 mm
Ground Clearance	140 mm
Angle of Departure	26 deg

For further information and exact pricing on our Mini Skid Steer Loaders, please contact us on **1300 449 844**

Email us at office@minimachinesdirect.com.au

Website www.minimachinesdirect.com.au



TM23T

Mini Skid Steer Loader - Track Drive – 23hp Briggs and Stratton Or Honda Petrol Engine

*** Ask us about Optional Pilot / Servo Control System ***

TASKMASTER



\$ 24,000 including GST

Includes 4/1 Bucket!! (Optional Teeth)

* RRP above includes GST Contact us for latest pricing *

For further information and exact pricing on our Mini Skid Steer Loaders, please contact us on **1300 449 844**

Email us at office@minimachinesdirect.com.au

Website www.minimachinesdirect.com.au



TM23T - STANDARD FEATURES

- **4 in 1 Bucket** – Doze, Dig, Dump, Carry, Clamp, Grab, Optional Teeth
- **Leveling Valve** – Keeps the Bucket Level when Raising the Arm
- **Large Alloy Radiator with Cooling Fan** – Efficient Cooling of Engine and Hydraulic Oil
- **Joystick Steering Control** – Manual (pilot operated optional)
- **Hydraulic Oil Cooler** – Keeps Oil Temperature in Check
- **Auxiliary Hydraulic Outputs** – Operate Many Work Tools
- **Hose Quick Coupler Fittings** – Italian Made Illuminates Dirt Entry and Leakage
- **Curved Lift Arms to Facilitate a Radial Lift Pattern** – Allows Attachments to Lift 'Up' and 'Out' Increasing Clearance to the Front of the Machine. Handy When Using Large Augers
- **CNC Manufacturing and Electrophoresis Paint Process** – For Rust Protection and an Excellent Finish
- **Large Donaldson Air Cleaner Primary/Secondary with Dust Venturi** – Longer Service Intervals (Optional Clogging Indicator)
- **Muffler Insulation** – Reduces Under Bonnet Temperature
- **Counterweights** – Increases Capacity
- **Hydrostatic Drive Train System** – Benefits of Hydraulic Power
- **Standard Attachment Mounting Plate** – Fits Most Common Attachments
- **Operator Platform Suspension** – Provides Great Visibility and Operator Comfort
- **Gauges and Warning Lights** – Machine Protection
- **Service Kit and Tools** – Maintenance items
- **Track Drive with Grease Tensioner and Heavy-Duty Recoil Spring** – More Traction and Lighter Footprint
- **Engine Access Panel Hinged and Lockable** – Allows Easy Access to All Major Components for Inspection and Servicing
- **Heat-Treated Pins and Greaseable Bronze Bushes** – For Longer Life
- **Tie Down Locations** – Safe Security for Transporting
- **Emergency Stop Switch** – Operator safety
- **Lift Hook Locations** – Safe Lifting of Machine
- **Key Locks on Access Panels and Fuel Caps** – For Security
- **Operators Manual** – Waterproof Holder for Safety and Protection
- **Reverse Stop Panel** – Operator Safety
- **LED Lights** – Day and Night Vision



For further information and exact pricing on our Mini Skid Steer Loaders, please contact us on **1300 449 844**

Email us at office@minimachinesdirect.com.au

Website www.minimachinesdirect.com.au



SPECIFICATIONS

ENGINE

Engine Make	Briggs and Stratton Vanguard 'V' Twin (USA) Or Honda
Fuel Type	Petrol
Rated Power	23 hp (17.1 kw)
Electrical	12 Volt / Alternator

HYDRAULIC SYSTEM

Pump Brand	Permco (USA)
Valve brand	Hydro Control Joystick (Italian)
Pressure	2610 PSI (180 Bar)
Flow	58 L/Min
Cooler	Alloy Cooling Radiator

DRIVING SYSTEM

Motor Brand	Danfoss (Danish)
Pressure	2610 PSI (180 Bar)
Flow	58 L/Min
Speed	6 Km/h

AUX CIRCUIT

Valve Brand	Trinity Flat Faced Couplers (Italian)
Pressure	2610 PSI (180 Bar)
Flow	58 L/Min

FLUID CAPACITIES

Fuel	23 L Petrol
Hydraulic Oil	30 L
Engine Oil	1.5 L
Coolant	

RATED LOAD

50% of Tip Capacity	200 kg (Optional Counterweight)
35% of Tip Capacity	140 kg (Optional Counterweight)
	See Our Lift Demo Videos! -Will Lift 400kg @ 600mm

DIMENTIONS

Height to Bucket Hinge Pin	1860 mm
Width	840 mm
Weight	870 kg
Height Max	2452 mm
Height Min	1370 mm
Length with Bucket	2170 mm
Length without Bucket	1740 mm
Wheelbase	720 mm
Ground Clearance	92 mm
Angle of Departure	26 deg

For further information and exact pricing on our Mini Skid Steer Loaders, please contact us on **1300 449 844**

Email us at office@minimachinesdirect.com.au

Website www.minimachinesdirect.com.au



TM30W

Mini Skid Steer Loader - Wheel Drive – 30hp Perkins Diesel Engine

*** Ask us about Optional Electric / Hydraulic AUX System ***

TASKMASTER



\$ 33,600 including GST

Includes 4/1 Bucket!! (Optional Teeth)

* RRP above includes GST Contact us for latest pricing *

For further information and exact pricing on our Mini Skid Steer Loaders, please contact us on **1300 449 844**

Email us at office@minimachinesdirect.com.au

Website www.minimachinesdirect.com.au



TM30W - STANDARD FEATURES

- **4 in 1 Bucket** – Doze, Dig, Dump, Carry, Clamp, Grab, Optional Teeth
- **Joystick Steering Control** – Soft Touch for Less Operator Fatigue
- **Leveling Valve** – Keeps the Bucket Level while Raising the Arm
- **Large Alloy Radiator with Cooling Fan** – Efficient Cooling of Diesel Engine and Hydraulic Oil
- **3 Hydraulic Pump System** – For Efficient Separation of Power to Attachments, Bucket Controls, and Wheels
- **Hydraulic Oil Cooler** – Keeps Oil Temperature in Check
- **Auxiliary Hydraulic Outputs** – Operate Many Work Tools
- **Hose Quick Coupler Fittings** – Italian Made Illuminates Dirt Entry and Leakage
- **Curved Lift Arms to Facilitate a Radial Lift Pattern** – Allows Attachments to Lift 'Up' and 'Out' Increasing Clearance to the Front of the Machine. Handy When Using Large Augers
- **CNC Manufacturing and Electrophoresis Paint Process** – For Rust Protection and an Excellent Finish
- **Large Donaldson Air Cleaner Primary/Secondary with Dust Venturi** – Longer Service Intervals (Optional Clogging Indicator)
- **Japanese NSK Bearings and Grade 60H Chains** – For Longer Life
- **Hydrostatic Drive Train System** – Benefits of Hydraulic Power
- **Muffler Insulation** – Reduces Under Bonnet Temperature
- **Counterweights** – Increases Capacity
- **Standard Attachment Mounting Plate** – Fits Most Common Attachments
- **Operator Platform Suspension** – Provides Great Visibility and Operator Comfort
- **Gauges and Warning Lights** – Machine Protection
- **Engine Access Panel Hinged and Lockable** – Allows Easy Access to All Major Components for Inspection and Servicing
- **Heat-Treated Pins and Greaseable Bronze Bushes** – For Longer Life
- **Tie Down Locations** – Safe Security for Transporting
- **Lift Hook Locations** – Safe Lifting of Machine
- **Key Locks on Access Panels and Fuel Caps** – For Security
- **Service Kit and Tools** – Maintenance items
- **Tires – 23x8.5-12** – Better ground Clearance (Optional Tread Patterns)
- **Emergency Stop Switch** – Operator safety
- **Operators Manual** – Waterproof Holder for Safety and Protection
- **Reverse Stop Panel** – Operator Safety
- **LED Lights** – Day and Night Vision



For further information and exact pricing on our Mini Skid Steer Loaders, please contact us on **1300 449 844**

Email us at office@minimachinesdirect.com.au

Website www.minimachinesdirect.com.au



SPECIFICATIONS

ENGINE

Engine Make	Perkins (United Kingdom)
Fuel Type	Diesel
Rated Power	30 hp (22.4 kw)
Electrical	12 Volt / Alternator

HYDRAULIC SYSTEM

Pump Brand	Hansa TMP (Italian) x3
Valve brand	Hydro Control Joystick (Italian)
Pressure	3625 PSI (250 Bar)
Flow	62.4 L/Min
Cooler	Alloy Cooler Radiator

DRIVING SYSTEM

Motor Brand	Danfoss (Danish)
Pressure	3625 PSI (250 Bar)
Flow	62.4 L/Min
Speed	8 Km/h

AUX CIRCUIT

Valve Brand	Trinity Flat Faced Couplers (Italian)
Pressure	2610 PSI (180 Bar)
Flow	36 L/Min

FLUID CAPACITIES

Fuel	35 L Diesel
Hydraulic Oil	35 L
Engine Oil	4.7 L
Coolant	

RATED LOAD

50% of Tip Capacity	400 kg (Optional Counterweight)
35% of Tip Capacity	280 kg (Optional Counterweight)
	See Our Lift Demo Videos! -Will Lift 800kg @ 600mm

DIMENSIONS

Height to Bucket Hinge Pin	1900 mm
Width	1060 mm
Weight	1200 kg
Height Max	2565 mm
Height Min	1600 mm
Length with Bucket	2702 mm
Length without Bucket	2075 mm
Wheelbase	769 mm
Ground Clearance	200 mm
Angle of Departure	23 deg

For further information and exact pricing on our Mini Skid Steer Loaders, please contact us on **1300 449 844**

Email us at office@minimachinesdirect.com.au

Website www.minimachinesdirect.com.au



TM30T

Mini Skid Steer Loader - Track Drive – 30hp Perkins Diesel Engine

*** Ask us about Optional Electric / Hydraulic AUX System ***

TASKMASTER



\$ 34,700 including GST

Includes 4/1 Bucket!! (Optional Teeth)

* RRP above includes GST Contact us for latest pricing *

For further information and exact pricing on our Mini Skid Steer Loaders, please contact us on **1300 449 844**

Email us at office@minimachinesdirect.com.au

Website www.minimachinesdirect.com.au



TM30T – STANDARD FEATURES

- **4 in 1 Bucket** – Doze, Dig, Dump, Carry, Clamp, Grab, Optional Teeth
- **Joystick Steering Control** – Soft Touch for Less Operator Fatigue
- **Leveling Valve** – Keeps the Bucket Level when Raising the Arm
- **Large Alloy Radiator with Cooling Fan** – Efficient Cooling of Diesel Engine and Hydraulic Oil
- **The 'Elevated Drive Sprocket' (as seen on most caterpillar dozers)** – Keeps the Drive Mechanism Further Out of the Dirt Reducing Wear – Allows the Drive System to Concentrate on Rotational Forces Without Having to Support the Weight of the Machine – Gives Much Smoother Ride for the Operator
- **3 Hydraulic Pump System** – For Efficient Separation of Power to Attachments, Bucket Controls, and Wheels
- **Hydraulic Oil Cooler** – Keeps Oil Temperature In Check
- **CNC Manufacturing and Electrophoresis Paint Process** – For Rust Protection and an Excellent Finish
- **Large Donaldson Air Cleaner Primary/Secondary with Dust Venturi** – Longer Service Intervals (Optional Clogging Indicator)
- **Auxiliary Hydraulic Outputs** – Operate Many Work Tools
- **Hose Quick Coupler Fittings** – Italian Made Illuminates Dirt Entry and Leakage
- **Curved Lift Arms to Facilitate a Radial Lift Pattern** – Allows Attachments to Lift 'Up' and 'Out' Increasing Clearance to the Front of the Machine. Handy When Using Large Augers
- **Hydrostatic Drive Train System** – Benefits of Hydraulic Power
- **Muffler Insulation** – Reduces Under Bonnet Temperature
- **Counterweights** – Added Lift Capacity
- **Standard Attachment Mounting Plate** – Fits Most Common Attachments
- **Operator Platform Suspension** – Provides Great Visibility and Operator Comfort
- **Gauges and Warning Lights** – Machine Protection
- **Track Drive with Grease Tensioner and Heavy-Duty Recoil Spring** – More Traction and Lighter Footprint
- **Engine Access Panel Hinged and Lockable** – Allows Easy Access to All Major Components for Inspection and Servicing
- **Heat-Treated Pins and Greaseable Bronze Bushes** – For Longer Life
- **Tie Down Locations** – Safe Security for Transporting
- **Key Locks on Access Panels and Fuel Caps** – For Security
- **Lift Hook Locations** – Safe Lifting of Machine
- **Service Kit and Tools** – Maintenance items
- **Lift Arm Safety Support** – Operator Safety
- **Operators Manual** – Waterproof Holder for safety and Protection
- **LED Lights** – Day and Night Vision
- **Emergency Stop Switch** – Operator safety



For further information and exact pricing on our Mini Skid Steer Loaders, please contact us on **1300 449 844**

Email us at office@minimachinesdirect.com.au

Website www.minimachinesdirect.com.au



SPECIFICATIONS

ENGINE

Engine Make	Perkins (United Kingdom)
Fuel Type	Diesel
Rated Power	30 hp (22.4 kw)
Electrical	12 Volt / Alternator

HYDRAULIC SYSTEM

Pump Brand	Hansa TMP (Italian) x3
Valve brand	Hydro Control Joystick (Italian)
Pressure	3625 PSI (250 Bar)
Flow	62.4 L/Min
Cooler	Alloy Cooler Radiator

DRIVING SYSTEM

Motor Brand	Danfoss (Danish)
Pressure	3625 PSI (250 Bar)
Flow	62.4 L/Min
Speed	8 Km/h

AUX CIRCUIT

Valve Brand	Trinity Flat Faced Couplers (Italian)
Pressure	2610 PSI (180 Bar)
Flow	36 L/Min

FLUID CAPACITIES

Fuel	35 L Diesel
Hydraulic Oil	35 L
Engine Oil	4.7 L
Coolant	

RATED LOAD

50% of Tip Capacity	400 kg (Optional Counterweight)
35% of Tip Capacity	280 kg (Optional Counterweight)
	See Our Lift Demo Videos! -Will Lift 800kg @ 600mm

DIMENSIONS

Height to Bucket Hinge Pin	2000 mm
Width	1070 mm
Weight	1330 kg
Height Max	2564 mm
Height Min	1600 mm
Length with Bucket	2695 mm
Length without Bucket	2067 mm
Wheelbase	1080 mm
Ground Clearance	220 mm
Angle of Departure	23 deg



For further information and exact pricing on our Mini Skid Steer Loaders, please contact us on **1300 449 844**

Email us at office@minimachinesdirect.com.au

Website www.minimachinesdirect.com.au



ML50T

Mini Skid Steer Loader - Track Drive – 50hp Kubota Diesel Engine

TASKMASTER



\$ 63,250 including GST

Including 4/1 Bucket! (Optional Teeth)

* RRP above includes GST Contact us for latest pricing *

For further information and exact pricing on our Mini Skid Steer Loaders, please contact us on **1300 449 844**

Email us at office@minimachinesdirect.com.au

Website www.minimachinesdirect.com.au



ML50T – STARDARD FEATURES

- **4 in 1 Bucket** – Doze, Dump, Carry, Clamp, Grab, Optional Teeth
- **Joystick Steering Control** – Soft Touch for Less Operator Fatigue
- **Lift Arm Float Control** – Spread Soil Easily by Back Blading
- **Large Alloy Radiator with Cooling Fan** – Efficient Cooling of Diesel Engine and Hydraulic Oil
- **Pilot Lock Out Switch** – Operator Safety
- **Park Brake Incorporated in Drive Motors** – Operator Safety
- **The 'Elevated Drive Sprocket' (as seen on most caterpillar dozers)** – Keeps the Drive Mechanism Further Out of the Dirt Reducing Wear – Allows the Drive System to Concentrate on Rotational Forces Without Having to Support the Weight of the Machine – Gives Much Smoother Ride for the Operator
- **3 Hydraulic Pump System** – For Efficient Separation of Power to Attachments, Bucket Controls, and Wheels
- **Hydraulic Oil Cooler** – Keeps Oil Temperature In Check
- **Auxiliary Hydraulic Outputs** – Operate Many Work Tools
- **Hose Quick Coupler Fittings** – Illuminates Dirt Entry and Leakage
- **Curved Lift Arms to Facilitate a Radial Lift Pattern** – Allows Attachments to Lift 'Up' and 'Out' Increasing Clearance to the Front of the Machine. Handy When Using Large Augers
- **Large Donaldson Air Cleaner Primary/Secondary with Dust Venturi** – Longer Service Intervals (Optional Clogging Indicator)
- **Hydrostatic Drive Train System** – Benefits of Hydraulic Power
- **Muffler Insulation** – Reduces Under Bonnet Temperature
- **Standard Attachment Mounting Plate** – Fits Most Common Attachments
- **Operator Platform Suspension** – Provides Great Visibility and Operator Comfort
- **Gauges and Warning Lights** – Machine Protection
- **Track Drive with Grease Tensioner and Heavy-Duty Re-coil Spring** – More Traction and Lighter Footprint
- **Engine Access Panel Hinged and Lockable** – Allows Easy Access to All Major Components for Inspection and Servicing
- **Hose Protection Kevlar Sleeving** – Burst Protection
- **Heat-Treated Pins and Greaseable Bronze Bushes** – For Longer Life
- **Lift Hook Locations** – Safe Lifting of Machine
- **Service Kit and Tools** – Maintenance items
- **Lift Arm Safety Support** – Operator Safety
- **Tie Down Locations** – Safe Security for Transporting
- **Key Locks on Access Panels and Fuel Caps** – For Security
- **Operators Manual** – Waterproof Holder for Safety and Protection
- **Reverse Stop Panel** – Operator Safety
- **LED Lights** – Day and Night Vision
- **Drink Holders** – Holds Refreshments or Phone



For further information and exact pricing on our Mini Skid Steer Loaders, please contact us on **1300 449 844**

Email us at office@minimachinesdirect.com.au

Website www.minimachinesdirect.com.au



SPECIFICATIONS

ENGINE

Engine Make	Kubota (Japan)
Fuel Type	Diesel
Rated Power	50 hp (35.7kw)
Electrical	12 Volt / Alternator

HYDRAULIC SYSTEM

Pump Brand	Hansa TMP (Italian) x3
Valve brand	Walvoil Joystick (Italian)
Pressure	3045 PSI (210 Bar)
Flow	59 L/Min
Cooler	Alloy Radiator

DRIVING SYSTEM

Motor Brand	Danfoss (Danish)
Pressure	3045 PSI (210 Bar)
Flow	59 L/Min
Speed	7.2 Km/h

AUX CIRCUIT

Valve Brand	Flat Faced Couplers ½ inch (Italian)
Pressure	2610 PSI (180 Bar)
Flow	59 L/Min

FLUID CAPACITIES

Fuel	65 L Petrol
Hydraulic Oil	62 L
Engine Oil	10 L
Coolant	14L

RATED LOAD

50% of Tip Capacity	544 kg
35% of Tip Capacity	380 kg

DIMENSIONS

Height to Bucket Hinge Pin	2478 mm
Width	1050 mm
Weight	1590 kg
Height Max	3263 mm
Height Min	1505 mm
Length with Bucket	2824 mm
Length without Bucket	2202 mm
Wheelbase	1170 mm
Ground Clearance	150 mm
Angle of Departure	22 deg

For further information and exact pricing on our Mini Skid Steer Loaders, please contact us on **1300 449 844**

Email us at office@minimachinesdirect.com.au

Website www.minimachinesdirect.com.au



TM60WR

Skid Steer Loader - Wheel Drive – 60hp Mitsubishi Diesel Engine

TASKMASTER



\$ 57, 000 including GST

Includes 4/1 Bucket!

* RRP above includes GST Contact us for latest pricing *

For further information and exact pricing on our Mini Skid Steer Loaders, please contact us on **1300 449 844**

Email us at office@minimachinesdirect.com.au

Website www.minimachinesdirect.com.au



TM60WR – STANDARD FEATURES

- **Mitsubishi Engine** (Other Brands Optional)
- **Air Conditioning** – Operator Comfort
- **4 in 1 Bucket** – Doze, Dig, Carry, Clamp, Grab, Optional Teeth
- **Joystick Steering Control** – Soft Touch for Less Operator Fatigue
- **Lift Arm Float Control** – Spread Soil Easily by Back Blading
- **Large Alloy Radiator with Cooling Fan** – Efficient Cooling of Diesel Engine and Hydraulic Oil
- **3 Hydraulic Pump System** – For Efficient Separation of Power to Attachments, Bucket Controls, and Wheels
- **Hydraulic Oil Cooler** – Keeps Oil Temperature In Check
- **Auxiliary Hydraulic Outputs** – Operate Many Work Tools
- **Hose Quick Coupler Fittings** – Italian Made Illuminates Dirt Entry and Leakage
- **Curved Lift Arms to Facilitate a Radial Lift Pattern** – Allows Attachments to Lift ‘Up’ and ‘Out’ Increasing Clearance to the Front of the Machine. Handy When Using Large Augers, Dumping Over A Wall, or Loading Flat Bed Trucks
- **CNC Manufacturing and Electrophoresis Paint Process** – For Rust Protection and an Excellent Finish
- **Japanese NSK Bearings and Grade 100H Chains** – For Longer Life
- **Large Donaldson Air Cleaner Primary/Secondary with Dust Venturi** – Longer Service Intervals (Optional Clogging Indicator)
- **Muffler Insulation** – Reduces Under Bonnet Temperature
- **Hydrostatic Drive Train System** – Benefits of Hydraulic Power
- **Rear View Mirrors** – Increased Operator Vision
- **Standard Attachment Mounting Plate** – Fits Most Common Attachments
- **High Quality Operator Station** – Provides Great Visibility, Roof Window, Sound Insulation, and Great Operator Comfort
- **Gauges and Warning Lights** – Machine Protection
- **Engine Access Panel Hinged and Lockable** – Allows Easy Access to All Major Components for Inspection and Servicing
- **Heat-Treated Pins and Greaseable Bronze Bushes** – For Longer Life
- **Tie Down Locations** - Safe Security for Transporting
- **Key Locks on Access Panels and Fuel Caps** – For Security
- **Emergency Stop Switch** – Operator safety
- **Lift Arm Safety Support** – Operator Safety
- **Lock Out Switch** – Locks the Pilot Oil Control System for Operator Safety
- **Brake System** – Operator Safety
- **Service Kit and Tools** – Maintenance items
- **Great Quality Tires 10x 16.5** – Better ground Clearance (Optional Tread Patterns)
- **Operators Manual** – Safety and Protection
- **LED Lights** – Day and Night Vision



For further information and exact pricing on our Mini Skid Steer Loaders, please contact us on **1300 449 844**

Email us at office@minimachinesdirect.com.au

Website www.minimachinesdirect.com.au



SPECIFICATIONS

ENGINE

Engine Make	Mitsubishi (Japan)
Fuel Type	Diesel
Rated Power	65 hp (45 kw)
Electrical	12 Volt / Alternator

HYDRAULIC SYSTEM

Pump Brand	Danfoss Sauer (Danish)
Pump Type	Tandem Axial Piston
Valve brand	Hydro Control Joystick (Italian)
Pressure	3045 PSI (210 Bar)
Flow	80 L/Min
Cooler	Alloy Radiator

DRIVING SYSTEM

Motor Brand	Danfoss Sauer (Danish)
Pressure	3045 PSI (210 Bar)
Flow	59 L/Min
Speed	Low Speed 12.2 Km/h

AUX CIRCUIT

Valve Brand	Trinity Flat Faced Couplers ½ inch (Italian)
Pressure	3045 PSI (210 Bar)
Flow	80 L/Min

FLUID CAPACITIES

Fuel	Diesel
Hydraulic Oil	
Engine Oil	
Coolant	

RATED LOAD

50% of Tip Capacity	800 kg
35% of Tip Capacity	560 kg
Tip Capacity	1600 kg

DIMENSIONS

Height to Bucket Hinge Pin	3000 mm
Width	1625 mm
Shipping Weight (no bucket)	
Operating Weight (full fuel, 80kg operator, bucket)	2810 kg
Height Max	3850 mm
Height Min	1980 mm
Length with Bucket	3046 mm
Length without Bucket	2708 mm
Wheelbase	1085 mm
Ground Clearance	186 mm
Angle of Departure	26 deg

For further information and exact pricing on our Mini Skid Steer Loaders, please contact us on **1300 449 844**

Email us at office@minimachinesdirect.com.au

Website www.minimachinesdirect.com.au



TM75WR

Skid Steer Loader - Wheel Drive – 75hp Kubota Diesel Engine

TASKMASTER



\$ 64,800 including GST

Includes 4/1 Bucket!

* RRP above includes GST Contact us for latest pricing *

For further information and exact pricing on our Mini Skid Steer Loaders, please contact us on **1300 449 844**

Email us at office@minimachinesdirect.com.au

Website www.minimachinesdirect.com.au



TM75WR – STANDARD FEATURES

- **Kubota Engine** (Other Brands Optional)
- **High Flow** – Operate Larger Attachments That Require High Speed/Torque
- **2 Speed Travel** – Get around the Jobsite more efficiently
- **Air Conditioning** – Operator Comfort
- **4 in 1 Bucket** – Doze, Dig, Carry, Clamp, Grab, Optional Teeth
- **Joystick Steering Control** – Soft Touch for Less Operator Fatigue
- **Lift Arm Float Control** – Spread Soil Easily by Back Blading
- **Large Alloy Radiator with Cooling Fan** – Efficient Cooling of Diesel Engine and Hydraulic Oil
- **3 Hydraulic Pump System** – For Efficient Separation of Power to Attachments, Bucket Controls, and Wheels
- **Hydraulic Oil Cooler** – Keeps Oil Temperature In Check
- **Auxiliary Hydraulic Outputs** – Operate Many Work Tools
- **Hose Quick Coupler Fittings** – Italian Made Illuminates Dirt Entry and Leakage
- **Curved Lift Arms to Facilitate a Radial Lift Pattern** – Allows Attachments to Lift ‘Up’ and ‘Out’ Increasing Clearance to the Front of the Machine. Handy When Using Large Augers, Dumping Over A Wall, or Loading Flat Bed Trucks
- **CNC Manufacturing and Electrophoresis Paint Process** – For Rust Protection and an Excellent Finish
- **Japanese NSK Bearings and Grade 100H Chains** – For Longer Life
- **Large Donaldson Air Cleaner Primary/Secondary with Dust Venturi** – Longer Service Intervals (Optional Clogging Indicator)
- **Muffler Insulation** – Reduces Under Bonnet Temperature
- **Hydrostatic Drive Train System** – Benefits of Hydraulic Power
- **Rear View Mirrors** – Increased Operator Vision
- **Standard Attachment Mounting Plate** – Fits Most Common Attachments
- **High Quality Operator Station** – Provides Great Visibility, Roof Window, Sound Insulation, and Great Operator Comfort
- **Gauges and Warning Lights** – Machine Protection
- **Engine Access Panel Hinged and Lockable** – Allows Easy Access to All Major Components for Inspection and Servicing
- **Heat-Treated Pins and Greaseable Bronze Bushes** – For Longer Life
- **Tie Down Locations**- Safe Security for Transporting
- **Key Locks on Access Panels and Fuel Caps** – For Security
- **Emergency Stop Switch** – Operator safety
- **Lift Arm Safety Support** – Operator Safety
- **Lock Out Switch** – Locks the Pilot Oil Control System for Operator Safety
- **Brake System** – Operator Safety
- **Service Kit and Tools** – Maintenance items
- **Great Quality Tires 10 x 16.5** – Better ground Clearance (Optional Tread Patterns)
- **Operators Manual** – Safety and Protection
- **LED Lights** – Day and Night Vision



For further information and exact pricing on our Mini Skid Steer Loaders, please contact us on **1300 449 844**
 Email us at office@minimachinesdirect.com.au
 Website www.minimachinesdirect.com.au



SPECIFICATIONS

ENGINE

Engine Make	Kubota (Japan)
Fuel Type	Diesel
Rated Power	75 hp (55 kw)
Electrical	12 Volt / Alternator

HYDRAULIC SYSTEM

Pump Brand	Danfoss Sauer (Danish)
Pump Type	Tandem Axial Piston
Valve brand	Hydro Control Joystick (Italian)
Pressure	3045 PSI (210 Bar)
Flow Low	80 L/Min
Cooler	Alloy Radiator

DRIVING SYSTEM

Motor Brand	Danfoss Sauer (Danish)
Pressure	3045 PSI (210 Bar)
Flow	80 L/Min
Speed Low	Speed 12.2 Km/h
Speed High	Speed 22.6 Km/h

AUX CIRCUIT

Valve Brand	Trinity Flat Faced Couplers ½ inch (Italian)
Pressure	3045 PSI (210 Bar)
Flow Low	80 L/Min
Flow High	128 L/Min

FLUID CAPACITIES

Fuel	Diesel
Hydraulic Oil	
Engine Oil	
Coolant	

RATED LOAD

50% of Tip Capacity	1000 kg
35% of Tip Capacity	700 kg
Tip Capacity	2000 kg

DIMENSIONS

Height to Bucket Hinge Pin	3000 mm
Width	1850 mm
Shipping Weight (no bucket)	
Operating Weight (full fuel, 80kg operator, bucket)	2960 kg
Height Max	4000 mm
Height Min	2028 mm
Length with Bucket	3523 mm
Length without Bucket	2733 mm
Wheelbase	1150 mm
Ground Clearance	215 mm
Angle of Departure	26 deg

For further information and exact pricing on our Mini Skid Steer Loaders, please contact us on **1300 449 844**

Email us at office@minimachinesdirect.com.au

Website www.minimachinesdirect.com.au



TM95WV

Skid Steer Loader. Wheel Drive – 95hp Kubota Diesel Engine

TASKMASTER



\$ 78,500 including GST

Includes 4/1 Bucket!!

* RRP above includes GST Contact us for latest pricing *

For further information and exact pricing on our Mini Skid Steer Loaders, please contact us on **1300 449 844**

Email us at office@minimachinesdirect.com.au

Website www.minimachinesdirect.com.au



TM95WV – STANDARD FEATURES

- **Kubota Engine** (Other Brands Optional)
- **High Flow** – Operate Larger Attachments That Require High Speed/Torque
- **2 Speed Travel** – Get around the Jobsite more efficiently
- **Air Conditioning** – Operator Comfort
- **4 in 1 Bucket** – Doze, Dig, Carry, Clamp, Grab, Optional Teeth
- **Joystick Steering Control** – Soft Touch for Less Operator Fatigue
- **Lift Arm Float Control** – Spread Soil Easily by Back Blading
- **Large Alloy Radiator with Cooling Fan** – Efficient Cooling of Diesel Engine and Hydraulic Oil
- **3 Hydraulic Pump System** – For Efficient Separation of Power to Attachments, Bucket Controls, and Wheels
- **Hydraulic Oil Cooler** – Keeps Oil Temperature In Check
- **Auxiliary Hydraulic Outputs** – Operate Many Work Tools
- **Hose Quick Coupler Fittings** – Italian Made Illuminates Dirt Entry and Leakage
- **Vertical Lift Pattern** – Keeps Centre of Gravity Constant. Handy for Stacking Pallets, Loading Trucks, Especially with Heavy Loads!
- **CNC Manufacturing and Electrophoresis Paint Process** – For Rust Protection and an Excellent Finish
- **Japanese NSK Bearings and Grade 100H Chains** – For Longer Life
- **Large Donaldson Air Cleaner Primary/Secondary with Dust Venturi** – Longer Service Intervals (Optional Clogging Indicator)
- **Muffler Insulation** – Reduces Under Bonnet Temperature
- **Hydrostatic Drive Train System** – Benefits of Hydraulic Power
- **Rear View Mirrors** – Increased Operator Vision
- **Standard Attachment Mounting Plate** – Fits Most Common Attachments
- **High Quality Operator Station** – Provides Great Visibility, Roof Window, Sound Insulation, and Great Operator Comfort
- **Gauges and Warning Lights** – Machine Protection
- **Engine Access Panel Hinged and Lockable** – Allows Easy Access to All Major Components for Inspection and Servicing
- **Heat-Treated Pins and Greaseable Bronze Bushes** – For Longer Life
- **Tie Down Locations** - Safe Security for Transporting
- **Key Locks on Access Panels and Fuel Caps** – For Security
- **Emergency Stop Switch** – Operator safety
- **Lift Arm Safety Support** – Operator Safety
- **Lock Out Switch** – Locks the Pilot Oil Control System for Operator Safety
- **Brake System** – Operator Safety
- **Service Kit and Tools** – Maintenance items
- **Great Quality Tires 10 x 16.5** – Better ground Clearance (Optional Tread Patterns)
- **Operators Manual** – Safety and Protection
- **LED Lights** – Day and Night Vision



For further information and exact pricing on our Mini Skid Steer Loaders, please contact us on **1300 449 844**

Email us at office@minimachinesdirect.com.au

Website www.minimachinesdirect.com.au



SPECIFICATIONS

ENGINE

Engine Make	Kubota (Japan)
Fuel Type	Diesel
Rated Power	95 hp (70.84 kw)
Electrical	12 Volt / Alternator

HYDRAULIC SYSTEM

Pump Brand	Danfoss Sauer (Danish)
Pump Type	Tandem Axial Piston
Valve brand	Hydro Control Joystick (Italian)
Pressure	3045 PSI (210 Bar)
Flow Low	80 L/Min
Cooler	Alloy Radiator

DRIVING SYSTEM

Motor Brand	Danfoss Sauer (Danish)
Pressure	3045 PSI (210 Bar)
Flow	80 L/Min
Speed Low	Speed 12.2 Km/h
Speed High	Speed 22.6 Km/h

AUX CIRCUIT

Valve Brand	Trinity Flat Faced Couplers ½ inch (Italian)
Pressure	3045 PSI (210 Bar)
Flow Low	80 L/Min
Flow High	158 L/Min

FLUID CAPACITIES

Fuel	Diesel
Hydraulic Oil	
Engine Oil	
Coolant	

RATED LOAD

50% of Tip Capacity	1600 kg
35% of Tip Capacity	1120 kg
Tip Capacity	3200 kg

DIMENSIONS

Height to Bucket Hinge Pin	3373 mm
Width	1837 mm
Shipping Weight (no bucket)	
Operating Weight (full fuel, 80kg operator, bucket)	3600 kg
Height Max	4224 mm
Height Min	2065 mm
Length with Bucket	3624 mm
Length without Bucket	2926 mm
Wheelbase	1227 mm
Ground Clearance	215 mm
Angle of Departure	26 deg

For further information and exact pricing on our Mini Skid Steer Loaders, please contact us on **1300 449 844**

Email us at office@minimachinesdirect.com.au

Website www.minimachinesdirect.com.au



TM 1.0

Mini Digger – 1.0 Ton Koop Diesel Engine

TASKMASTER



\$ 15,389 Including GST

Includes Quick hitch, 600mm Batter Bucket, 300mm Rock Bucket (teeth), 200mm Trenching Bucket (teeth), Ripper, and Rake

* RRP above includes GST Contact us for latest pricing *

For further information and exact pricing on our Mini Skid Steer Loaders, please contact us on **1300 449 844**

Email us at office@minimachinesdirect.com.au

Website www.minimachinesdirect.com.au



TM 1.0 - STANDARD FEATURES

- **Joystick Operated Controls**
- **Auxiliary Hydraulic Outputs** – Operate Many Work Tools
- **CNC Manufacturing and Electrophoresis Paint Process** – For Rust Protection and an Excellent Finish
- **Hose Quick Coupler Fittings** – Illuminates Dirt Entry and Leakage
- **Hydrostatic Drive Train System** – Benefits of Hydraulic Power
- **ROPS** – Roll Over Protection Structure
- **Sunshade** – Operator Protection
- **Rubber Floor Mat** – Easy to Clean
- **Hydraulic Blade** – Makes Back Filling Easy
- **Quick Hitch** – Easy to Change Buckets
- **Engine Access Cover** – Easy to Lift Cover for Servicing
- **Rubber Tracks** – Avoid Damage to Surfaces
- **Tie Down Locations** – Safe Security for Transporting
- **Service Kit and Tools** – Maintenance items
- **Operators Manual** – Safety and Protection
- **Hose Protection** – Better Abrasion Resistance



For further information and exact pricing on our Mini Skid Steer Loaders, please contact us on **1300 449 844**

Email us at office@minimachinesdirect.com.au

Website www.minimachinesdirect.com.au



SPECIFICATIONS & DIMENSIONS

Overall dimensions	Unit: mm
A Wheel track	770
B Overall length of track	1090
C Ground clearance of platform	380
D Ground clearance of platform tail	784
E Chassis width	896
F Crawler width	170
H Crawler height	320
I Transportation length	2770
J Overall height	1330

Work range	Unit: mm
A Max. digging radius on ground	2850
B Max. digging depth	1650
C Max. digging height	2610
D Max. unloading height	1850
E Max. vertical digging depth	1375
F Min. swing radius	1330
G Max. lifting height of dozer blade	345
H Max. digging depth of dozer blade	255

Performance parameters	
Weight of complete machine kg	880
Standard bucket capacity m ³	0.025
Rated power kw	7.5

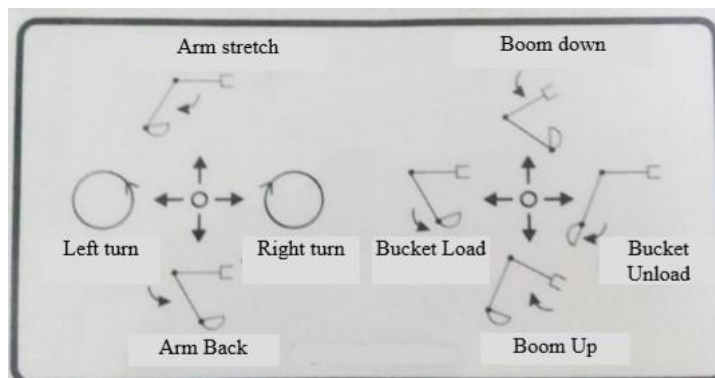
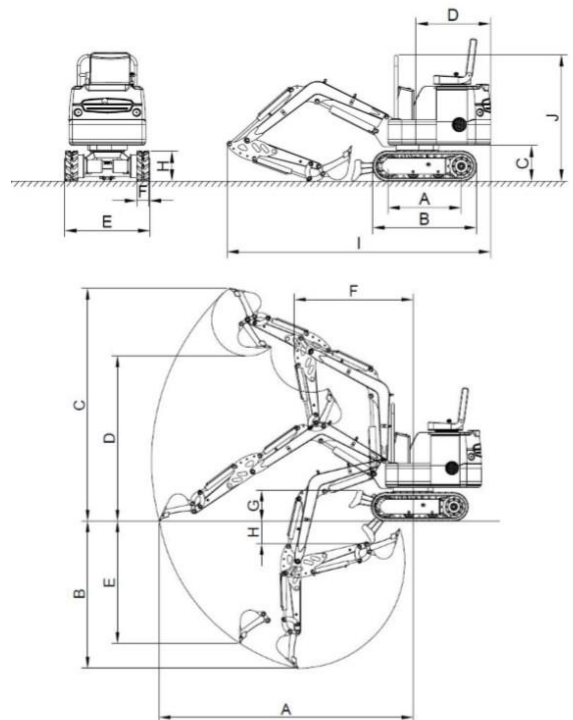

For further information and exact pricing on our Mini Skid Steer Loaders, please contact us on **1300 449 844**
 Email us at office@minimachinesdirect.com.au
 Website www.minimachinesdirect.com.au



TM 1.7

Mini Digger – 1.7 Ton Yanmar Diesel Engine

TASKMASTER



\$ 26,300 Including GST

Includes Quick Hitch, 600mm Batter Bucket, 300mm Rock Bucket (teeth), 200mm Trenching Bucket (teeth) Ripper, and Rake

* RRP above includes GST Contact us for latest pricing *

For further information and exact pricing on our Mini Skid Steer Loaders, please contact us on **1300 449 844**

Email us at office@minimachinesdirect.com.au

Website www.minimachinesdirect.com.au



TM 1.7 - STANDARD FEATURES

- **Hydraulic Blade** – Makes Back Filling Easy
- **Hydraulic Oil Cooler** – Keeps Oil Temperature In Check
- **Joystick Operated Controls**
- **CNC Manufacturing and Electrophoresis Paint Process** – For Rust Protection and an Excellent Finish
- **Auxiliary Hydraulic Outputs** – Operate Many Work Tools
- **Hose Quick Coupler Fittings** – Illuminates Dirt Entry and Leakage
- **Large Donaldson Air Cleaner Primary/Secondary with Dust Venturi** – Longer Service Intervals (Optional Clogging Indicator)
- **Hydrostatic Drive Train System** – Benefits of Hydraulic Power
- **Adjustable Seat** – Great Comfort and All-Round Vision
- **Rubber Floor Mat** – Easy to Clean
- **Yanmar Engine** – Japan
- **Quick Hitch** – Easy to Change Buckets
- **Rubber Tracks** – Avoid Damages to Surfaces
- **Gauges and Warning Lights** – Machine Protection
- **Engine Access Panel Hinged and Lockable** – Allows Easy Access to All Major Components for Inspection and Servicing
- **Tie Down Locations** – Safe Security for Transporting
- **Service Kit and Tools** – Maintenance items
- **Operators Manual** – Safety and Protection
- **LED Lights** – Night Vision
- **Hose Protection** – Better Abrasion Resistance
- **Sunshade** – Operator Protection from UV
- **ROPS** – Roll Over Protection Structure



For further information and exact pricing on our Mini Skid Steer Loaders, please contact us on **1300 449 844**

Email us at office@minimachinesdirect.com.au

Website www.minimachinesdirect.com.au



SPECIFICATIONS & DIMENTIONS

Brand	TM 1.7
Operating Weight	1470kg
Digging bucket capacity	0.045cbm
Engine	Japan YANMAR (3TNV70)
Rated power	10kw/2200r/min
Displacement	0.854 L
Bore stroke	
Main pump	Kadekor (Permco copy)
Displacement	23.3 L/min
Swing motor	EATON
Traveling motor	Korea DONGHYUN
Travel speed	1.5 km/h

MAIN DIMENSIONS	
Overall dimension(LxWxH)	3160x1040x2377mm
a. Wheel distance	1130mm
b. Total length of track	1450mm
c. Platform ground clearance	437mm
d. Platform back turning radius	740mm
e. Chassis width	1040mm
f. Track width	180mm
g. Chassis ground clearance	437mm
OPERATING RANGE	
A. Max. Digging radius on ground	3470 mm
B. Max. Digging radius	3560 mm
C. Max. Digging depth	2150 mm
D. Max. Digging height	3275 mm

For further information and exact pricing on our Mini Skid Steer Loaders, please contact us on **1300 449 844**

Email us at office@minimachinesdirect.com.au

Website www.minimachinesdirect.com.au



TM 1.8

Mini Digger – 1.8 Ton Yanmar Diesel Engine

TASKMASTER



\$ 30,700 Including GST

Includes Quick Hitch, 600mm Batter Bucket, 300mm Rock Bucket (teeth), 200mm Trenching Bucket (teeth), Ripper, and Rake

* RRP above includes GST Contact us for latest pricing *

For further information and exact pricing on our Mini Skid Steer Loaders, please contact us on **1300 449 844**

Email us at office@minimachinesdirect.com.au

Website www.minimachinesdirect.com.au



TM 1.8 - STANDARD FEATURES

- **Yanmar Engine** – Japan
- **Joystick Operated Controls** – Pilot Servo for Soft touch
- **Hydraulic Blade** – Makes back Filling Easy
- **Hydraulic Oil Cooler** – Keeps Oil Temperature in Check
- **Adjustable Arm Rests** – Less Operator Fatigue
- **Auxiliary Hydraulic Outputs** – Operate Many Work Tools
- **CNC Manufacturing and Electrophoresis Paint Process** – For Rust Protection and an Excellent Finish
- **Quick Hitch** – Easy to Change Buckets
- **Hose Quick Coupler Fittings** – Illuminates Dirt Entry and Leakage
- **Large Donaldson Air Cleaner Primary/Secondary with Dust Venturi** – Longer Service Intervals (Optional Clogging Indicator)
- **Hydrostatic Drive Train System** – Benefits of Hydraulic Power
- **Rubber Floor Matt** – Easy to Clean
- **Rubber Tracks** – Avoids Damage to Surfaces
- **2 Speed Travel** – Faster travel Speed
- **Boom Side Swing** – Allows Very Close Digging to Walls
- **Key Locks on Access Panels and Fuel Caps** – For Security
- **Gauges and Warning Lights** – Machine Protection
- **Engine Access Panel Hinged and Lockable** – Allows Easy Access to All Major Components for Inspection and Servicing
- **Tie Down Locations** – Safe Security for Transporting
- **Service Kit and Tools** – Maintenance items
- **Operators Manual** – Safety and Protection
- **LED Lights** – Night Vision
- **Hose Protection** – Better Abrasion Resistance
- **ROPS** – Roll Over Protection Structure
- **Adjustable Seat** – Great Comfort and All-Round Vision
- **Sunshade** – Operator Protection from UV



For further information and exact pricing on our Mini Skid Steer Loaders, please contact us on **1300 449 844**

Email us at office@minimachinesdirect.com.au

Website www.minimachinesdirect.com.au



SPECIFICATIONS & DIMENSIONS

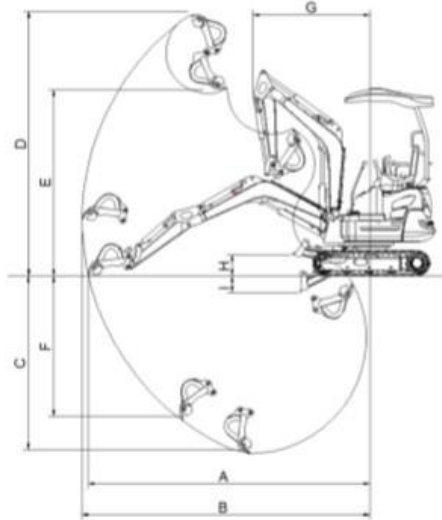

Work range		Unit: mm
A	Ground maximum digging radius	3470
B	Maximum digging radius	3560
C	Maximum digging depth	2150
D	Maximum digging height	3275
E	Maximum dumping height	2310
F	Maximum vertical digging depth	1740
G	Minimum slewing radius	1440
H	Maximum lifting height of bulldozing blade	285
I	Maximum digging depth of bulldozing blade	195

TM 1.8		Technical parameters	Unit		
Overall weight			kg	1700	
Bucket capacity			m ³	0.045	
Type of working device				Backhoe	
Engine	Model			Yanmar 3TNV70	
	Displacement		L	0.854	
	Rated output power/speed		kw/r/min	10/2200	
	Maximum torque/rotating speed		N.m/r/min	51.9/1600	
Speed and digging force	Maximum traveling speed (High/low)		km/h	3.4/1.9	
	Slewing speed		rpm	10.5	
	Maximum gradeability			30(58%)	
	Bucket digging force		KN	13.5	
	Bucket arm digging force		KN	10.1	
	Theoretic maximum traction force		KN	17.5	
Dimensions	Overall length		mm	3300	
	Overall width		mm	Rubber 1120/ Steel 1220	
	Overall height (With roll cage)		mm	2320	
	Bulldozing blade	Maximum cleaning depth		mm	180
		Maximum lifting height		mm	285
Track subassembly	Ground pressure		kPa	32.8	
	Tracks	Material		Steel tracks / Rubber Tracks	
		Tension control type			Grease cylinder
Hydraulic oil tank capacity			(L)	15.3	
Maximum engine oil capacity (Effective)			(L)	2.8(1.3)	
Fuel tank capacity			(L)	19	

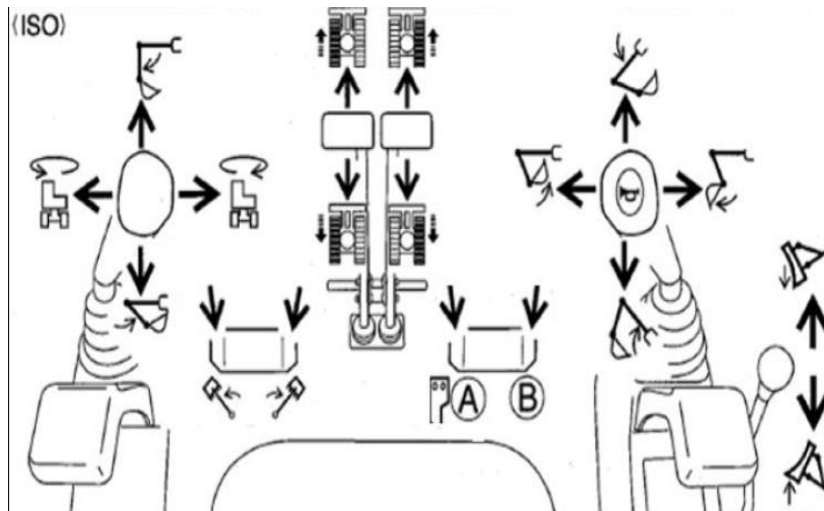

For further information and exact pricing on our Mini Skid Steer Loaders, please contact us on **1300 449 844**
 Email us at office@minimachinesdirect.com.au
 Website www.minimachinesdirect.com.au



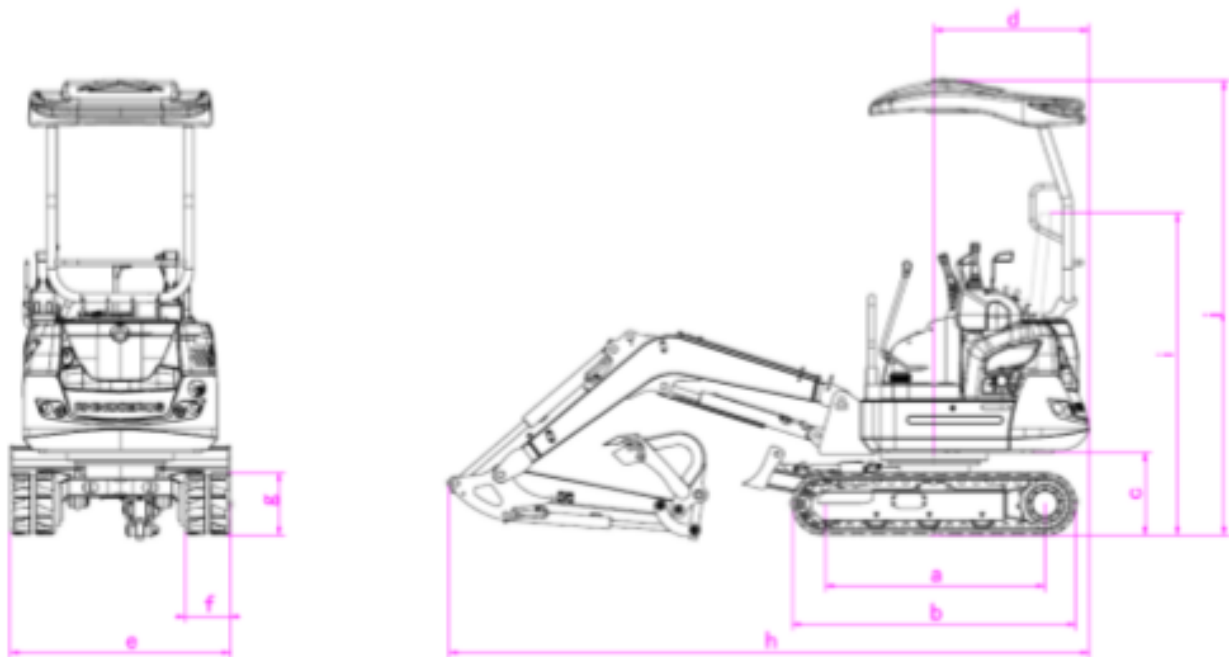

Overall dimensions		Unit: mm
a	Wheel track	Rubber 1130/ Steel 1250
b	Overall length of crawler	1450
c	Ground clearance of platform	473
d	Tail slewing radius of platform	740
e	Chassis width	Rubber 1120/ Steel 1220
f	Track width	230
g	Track height	360
h	Transport length	3300
i	Ground clearance of seat	1660
j	Overall height	2380

For further information and exact pricing on our Mini Skid Steer Loaders, please contact us on **1300 449 844**
 Email us at office@minimachinesdirect.com.au
 Website www.minimachinesdirect.com.au



TM 2.0

Mini Digger – 2.0 Ton Yanmar Diesel Engine

TASKMASTER



\$ 35,000 Including GST

Includes Quick Hitch, 600mm Batter Bucket, 300mm Rock Bucket (teeth), 200mm Trenching Bucket (teeth), Ripper, and Rake

* RRP above includes GST Contact us for latest pricing *

For further information and exact pricing on our Mini Skid Steer Loaders, please contact us on **1300 449 844**

Email us at office@minimachinesdirect.com.au

Website www.minimachinesdirect.com.au



TM 2.0 - STANDARD FEATURES

- **Yanmar Engine** – Japan
- **Joystick Operated Controls** – Pilot Servo for Soft touch Precision
- **Hydraulic Blade** – Makes back Filling Easy
- **Hydraulic Oil Cooler** – Keeps Oil Temperature in Check
- **Adjustable Arm Rests** – Less Operator Fatigue
- **Auxiliary Hydraulic Outputs** – Operate Many Work Tools
- **CNC Manufacturing and Electrophoresis Paint Process** – For Rust Protection and an Excellent Finish
- **Quick Hitch** – Easy to Change Buckets
- **Hose Quick Coupler Fittings** – Illuminates Dirt Entry and Leakage
- **Large Donaldson Air Cleaner Primary/Secondary with Dust Venturi** – Longer Service Intervals (Optional Clogging Indicator)
- **Hydrostatic Drive Train System** – Benefits of Hydraulic Power
- **Rubber Floor Matt** – Easy to Clean
- **Rubber Tracks** – Avoids Damage to Surfaces
- **Expandable Tracks** – Can Fit Through Narrow Gaps, then Expand for Better Stability
- **2 Speed Travel** – Faster travel Speed
- **Boom Side Swing** – Allows Very Close Digging to Walls
- **Key Locks on Access Panels and Fuel Caps** – For Security
- **Gauges and Warning Lights** – Machine Protection
- **Engine Access Panel Hinged and Lockable** – Allows Easy Access to All Major Components for Inspection and Servicing
- **Tie Down Locations** – Safe Security for Transporting
- **Service Kit and Tools** – Maintenance items
- **Operators Manual** – Safety and Protection
- **LED Lights** – Night Vision
- **Hose Protection** – Better Abrasion Resistance
- **ROPS** – Roll Over Protection Structure
- **Adjustable Seat** – Great Comfort and All-Round Vision
- **Sunshade** – Operator Protection from UV



For further information and exact pricing on our Mini Skid Steer Loaders, please contact us on **1300 449 844**

Email us at office@minimachinesdirect.com.au

Website www.minimachinesdirect.com.au



SPECIFICATIONS & DIMENSIONS

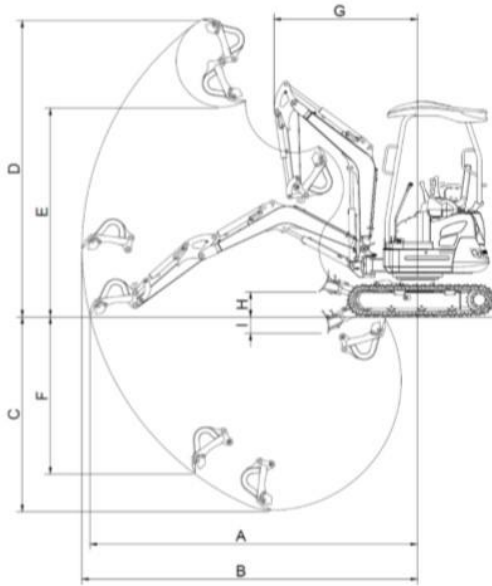

Working range		Unit: mm
A	Ground maximum digging radius	3610
B	Maximum digging radius	3700
C	Maximum digging depth	2150
D	Maximum lifting height	3275
E	Maximum Dump row type level and	2310
F	Maximum vertical digging depth	1740
G	Minimum slewing radius	1580
H	Maximum lifting height of bulldozing blade	275
I	Maximum digging depth of bulldozing blade	180

TM 2.0		Technical parameters	Unit		
Overall weight			kg	1880	
Bucket capacity			m ³	0.045	
Type of working device				Backhoe	
		Model		Yanmar 3TNV70	
Engine		Displacement	L	0.854	
		Rated output power/speed	kw/r/min	10/2200	
		Maximum torque/rotating speed	N.m/r/min	51.9/1600	
Speed and digging force		Maximum traveling speed (High/low)	km/h	3.4/1.9	
		Slewing speed	rpm	10.5	
		Maximum gradeability		30(58%)	
		Bucket digging force	KN	13.5	
		Bucket arm digging force	KN	10.1	
		Theoretic maximum traction force	KN	17.5	
Dimensions		Overall length	mm	3400	
		Overall width	mm	990/1240	
		Overall height (With roll cage)	mm	2380	
		Bulldozing blade	Maximum cleaning depth	mm	180
Maximum lifting height	mm		275		
Track subassembly		Ground pressure		kPa	32.8
		Tracks	Material		Steel tracks
			Tension control type		Grease cylinder
		Type of pump			Plunger pump
Fuel/oil/fluid pressure and capacity		Working pressure		MPa	22
		Flow		(L/min)	2x17+14
		Hydraulic oil tank capacity		(L)	15.3
		Maximum engine oil capacity (Effective)		(L)	2.8(1.3)
		Fuel tank capacity		(L)	19

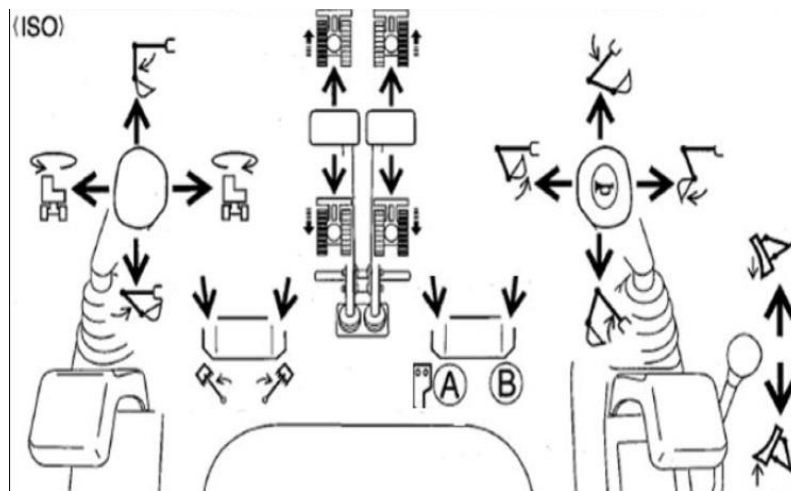

For further information and exact pricing on our Mini Skid Steer Loaders, please contact us on **1300 449 844**
 Email us at office@minimachinesdirect.com.au
 Website www.minimachinesdirect.com.au



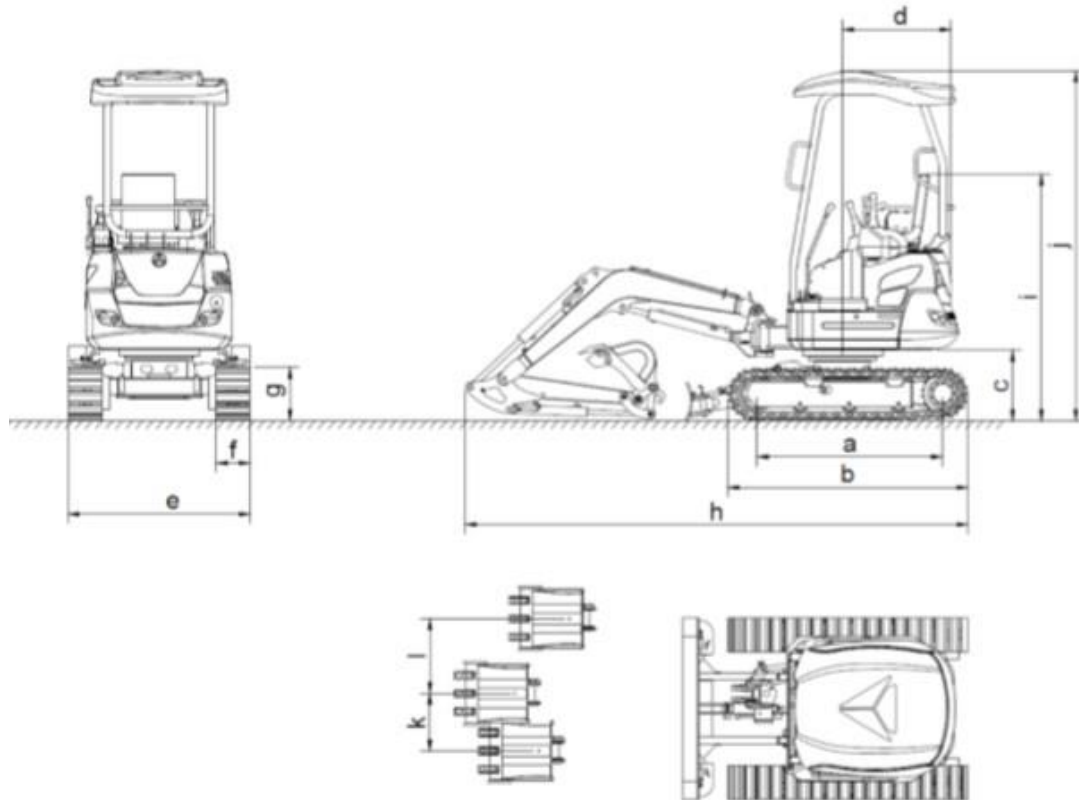

Overall dimensions		Unit: mm
a	Wheel track	1230
b	Overall length of crawler	1590
c	Ground clearance of platform	473
d	Tail slewing radius of platform	740
e	Chassis width	990 (1240)
f	Track width	230
g	Track height	360
h	Transport length	3400
i	Ground clearance of seat	1660
j	Overall height	2380
k	Boom slewing - Left	390
l	Boom slewing - Right	510

For further information and exact pricing on our Mini Skid Steer Loaders, please contact us on **1300 449 844**

Email us at office@minimachinesdirect.com.au

Website www.minimachinesdirect.com.au





PLANT TRAILER

Heavy Duty Plant Trailer – with Attachment Holder Rack

TASKMASTER



\$ 10,500 including GST

Including Attachment Holders

* RRP above includes GST Contact us for latest pricing *

For further information and exact pricing on our Mini Skid Steer Loaders, please contact us on **1300 449 844**

Email us at office@minimachinesdirect.com.au

Website www.minimachinesdirect.com.au



PLANT TRAILER - STANDARD FEATURES

- Australia Made
- Dual Axle
- 3,200mm X 1500mm x 3mm Deck
- 700kg / 800kg Tare Weight
- 2,000kg Load Capacity
- 5 New Tires (Spare Wheel)
- Roller Rocker Suspension
- 50mm Coupling
- Heavy Duty Ramps
- High Quality Bearings
- Side Steps
- No Doubt – This Trailer is Strong!!
- Tie Down Location Points
- Electric Brakes on All Wheels
- Rear Corner Adjustable Stabilizer Legs
- Heavy Duty Draw Bar
- LED Lights
- 10" Electric Brakes with Break-Away Unit
- Hi-Vis Safety Reflective Tape
- Wheel Nut Indicators
- Ask About Our Bluetooth Wireless Brake controller
- Attachment Holders – 3 x Auger, 1 x Auger Drive, 1 x Trencher, 1 x Spreader Bar



For further information and exact pricing on our Mini Skid Steer Loaders, please contact us on **1300 449 844**

Email us at office@minimachinesdirect.com.au

Website www.minimachinesdirect.com.au



SPECIFICATIONS

RATED LOAD

Aggregate Trailer Mass (ATM)	2,800 kg
Tare Weight	800 kg
Carrying Capacity	2,000 kg

DIMENSIONS

Overall Width	2,000 mm
Overall Length (Including Drawbar)	5,100 mm
Deck Width	1,500 mm
Deck Length	3,200 mm
Overall Height	2,010 mm

For further information and exact pricing on our Mini Skid Steer Loaders, please contact us on **1300 449 844**

Email us at office@minimachinesdirect.com.au

Website www.minimachinesdirect.com.au



Trailer Brake Controller – Bluetooth – \$684

(Optional Wireless Remote \$174)

(Optional Plug and Play Harness \$85)



* RRP above includes GST Contact us for latest pricing *

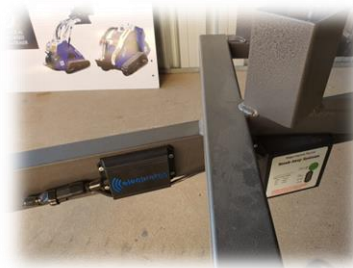

- Australian Designed
- Perfect for use on Trailers that may be towed by many vehicles
- Zero Wiring Needed on Tow Vehicle – Use Smart Phone or Wireless Remote
- Mounts to Trailer – use a Plug and Play Harness, or Hard Wire it
- Water / Dust / Shock Proof
- Programable Memory
- Dual Power Supply, 12/24 volt – Takes power from Rear Lights and Brake Lights
- Monitor and control your trailer's brakes with your smartphone
- Latest Proportional Braking Technology
- Waterproof & shock proof
- Easy mounting

Elecbrake Brake Controller comes with a 1.5mtr Leader Harness for the purpose of hard wiring the device to the Trailers electrical circuit. Plug and Play Break Harness and Remote Control are Optional

For further information and exact pricing on our Mini Skid Steer Loaders, please contact us on **1300 449 844**

Email us at office@minimachinesdirect.com.au

Website www.minimachinesdirect.com.au



Trencher – MT600 – \$5,574

* RRP above includes GST Contact us for latest pricing *

Includes Mounting Plate and Chain, and Hoses

Trencher MT600 Planetary Drive. Auger Torque. 150mm Width Chain. 50% Earth Teeth and 50% Tungsten Teeth. 600mm Trenching Depth. Includes Quick Couplers, Hoses, Depth Skid Plate, Spring-Loaded Trench Cleaning Bar and Mini Loader Mount Plate.

- **Anti-Flex Back Chain** – Reduces Wind Up of Chain
- **Trench Cleaning Bar** – Spring Loaded to Start Dig Easy. It can be Pinned Back when Not in Use
- **Quick Couplers** – Leak free and Illuminates Dirt Entry
- **Skid Plate**– Adjusts the Cutting Depth
- **Tungsten Teeth** – Wear Resistance
- **Planetary Drive Gearing** – Super High Torque
- **Best in Industry Warranty**– 6 Year Gear Box, 3 Year Drive Motor
- **Custom Build** – Ask Us About Different Options for Your Requirements
- Large Spoil Auger, Trench Cleaner Bar, Safety Guard, Adjustable Depth Skid Plate, Eaton Drive Motor



For further information and exact pricing on our Mini Skid Steer Loaders, please contact us on **1300 449 844**

Email us at office@minimachinesdirect.com.au

Website www.minimachinesdirect.com.au



Auger Drive – ML2500 – \$2,345

* RRP above includes GST Contact us for latest pricing *

Includes Mounting Plate, Pin, and Hoses

Auger Drive MT2500 65mm Drive 4 Way Swing / Lockable. Includes Quick Couplers, Hoses, Pin / Clip, and Mini Loader Mount Plate.

- **Swings 4 Axis (not 2)** – For dead Straight Holes on a hill.
- **Lockable Swing** – Can Be locked for Horizontal Drilling or to Accommodate a Mixer Bowl
- **Quick Couplers** – Leak free and Illuminates Dirt Entry
- **Encapsulated Drive** – Operator Safety, Drive Cannot Dislodge
- **Planetary drive Gearing** – Super High Torque
- **Best in Industry Warranty**– 6 Year Gear Box, 3 Year Drive Motor
- **Custom Build** – Ask Us About Different Options for Your Requirements



For further information and exact pricing on our Mini Skid Steer Loaders, please contact us on **1300 449 844**

Email us at office@minimachinesdirect.com.au

Website www.minimachinesdirect.com.au



Auger – 300mm – \$780

* RRP above includes GST Contact us for latest pricing *

Includes Tungsten Teeth and Tungsten Pilot

Auger – 300mm. Tungsten Teeth. Tungsten Pilot. 1200mm Long. 65mm Round.

- **Tungsten Teeth** – Longer Life
- **Tungsten Pilot** – Longer Life
- **1200mm Long** – Deep Holes
- **65mm Round** – Common Size. Fits Many Drive Brands (or custom drive available)
- **Custom Build** – Ask Us About Different Options for Your Requirements



For further information and exact pricing on our Mini Skid Steer Loaders, please contact us on **1300 449 844**

Email us at office@minimachinesdirect.com.au

Website www.minimachinesdirect.com.au





Bucket – 4 in 1 Multifunctional Design – \$3,735 (optional tooth kit \$300)

* RRP above includes GST Contact us for latest pricing *

Bucket 4 in 1 Design. 1225mm Wide. Standard Volume. Mini Loader Mounting.

- **Thickness** – 12mm Hardox Plate
- **Width** – 1225mm
- **Volume** – 0.14m³
- **Weight** – 159kg
- **Australian Made**
- **Multifunctional 4/1 Design** – Dose, Dig, Dump, Carry, Clamp, Grab
- **Mini Loader Mounting Plate** – Common Size. Fits Many Brands
- **Option Teeth** – Better Digging



For further information and exact pricing on our Mini Skid Steer Loaders, please contact us on **1300 449 844**

Email us at office@minimachinesdirect.com.au

Website www.minimachinesdirect.com.au





Pallet Forks

* RRP includes GST Contact us for latest pricing *

Digga Pallet Forks – Floating Tyne. 900kg Rated. Includes Backrest. Mini Loader Mounting. Adjustable Tyne

\$1,285 * RRP includes GST Contact us for latest pricing *



- **Tyne Width** – Adjustable to 1224mm
- **Tyne Length** – 1270mm
- **Weight** – 110mm
- **Back Rest** – Stops Load falling Back While Still Providing Good Visibility
- **Mini Loader Mounting Plate** – Common Size. Fits Many Brands
- **Large capacity**
- **Floating Tyne** – For Safety, the Tyne's Can Swing Freely. If Tilted Forward They Remain Horizontal
- **Australian Made**



Himac Pallet Forks – Fixed Tyne 900kg Rated. Includes Backrest. Mini Loader Mounting. Adjustable Tyne

\$1033 * RRP includes GST Contact us for latest pricing *



- **Back Rest** – Stops Load falling Back While Still Providing Good Visibility
- **Mini Loader Mounting Plate** – Common Size. Fits Many Brands
- **Large capacity**
- **Fixed Tyne Heal**
- **Australian Made**



For further information and exact pricing on our Mini Skid Steer Loaders, please contact us on **1300 449 844**

Email us at office@minimachinesdirect.com.au

Website www.minimachinesdirect.com.au



Mixer Bowl – 180L – \$720

** RRP above includes GST Contact us for latest pricing **

Mixer Bowl – 180 L. 65mm Round.

- **Large Capacity**
- **Use with Auger Drive**, Then Just Tip Contents out with your Loader Tilt Function
- **Custom Build** – Ask Us About Different Options for Your Requirements
- **65mm Round** – Common Size. Fits Many Drive Brands



Baffles for Efficient Mixing



Easily Fits on your Auger Drive



65mm Round Drive



For further information and exact pricing on our Mini Skid Steer Loaders, please contact us on **1300 449 844**

Email us at office@minimachinesdirect.com.au

Website www.minimachinesdirect.com.au



Mini Tilt Hitch - \$3,780

** RRP above includes GST Contact us for latest pricing **

The Build and design of this product is unbelievably good!!!

- Multi Fit Design – Fits all Machines
- 70 Degree Tilt
- Super Low Profile – Compact design for maximum break out force
- Greaseable and Harden Pins – For Longer Life Cycle
- Lifting Eye
- CNC Machined Cast Body – The Design Technology is incredible!
- 3 Year Warranty – Speaks for itself
- Draw Pin Feature – Easy to change Buckets and Attachments



For further information and exact pricing on our Mini Skid Steer Loaders, please contact us on **1300 449 844**

Email us at office@minimachinesdirect.com.au

Website www.minimachinesdirect.com.au



The Next Step Today

Service always comes first at **Mini Machines Direct**. We do everything we can to make the process of ordering **Machines, Attachments, Parts, and Trailers** from our **Taskmaster** range as effortless for you as possible.

Remember, waiting around is worse than just doing nothing.

If you are unsure about something, then call us and we will make sure that what we sell you is suitable for you and your business, and we can give recommendations about our products to make sure it's the right kind of machine for you.

Simple Ordering Process

- 1) Read though our products
- 2) Write down any questions so we can cover off on them
- 3) Talk to us and we will organize an exact quote
- 4) Quote follow up and any amendments or questions will be covered
- 5) Decide how you will pay for the order.
If finance our finance broker will go through with you and get pre-approval
- 6) Delivery will be discussed
- 7) We send the invoice though to you.
- 8) We can offer a simple 2 step payment process to help with your cashflow.
- 9) Your goods will be on its way you!

CONGRATUALIONS YOU'LL SOON BE ENJOYING YOUR NEW MACHINE!!



1300 449 844

Thank You

Craig and theTeam

Mini Machines Direct

"One Taskmaster for A Range Of Tasks."

For further information and exact pricing on our Mini Skid Steer Loaders, please contact us on **1300 449 844**

Email us at office@minimachinesdirect.com.au

Website www.minimachinesdirect.com.au

