

# TECUMSEH

TECHNICIAN'S HANDBOOK

## TC/TM SERIES

## 2-Cycle Engines



ENGINES & TRANSMISSIONS

## IMPORTANT NOTICE!

This handbook covers repairs and adjustments not covered within the Operator's Manual, and it is intended for individuals who have a general understanding of internal combustion engines, adequate training, experience and who practice proper tool usage. Service procedures should be clearly understood and practiced when servicing Tecumseh Engines.

## Safety Definitions

Statements in this manual preceded by the following words and graphics are of special significance:



**WARNING**

Or



**WARNING**

WARNING indicates a potentially hazardous situation which if not avoided, could result in death or serious injury.

### NOTE

*Refers to important information and is placed in italic type.*

It is recommended that you take special notice of all items discussed on pages 1 and 2 and wear the appropriate safety equipment.

## Notice Regarding Emissions

### NOTE

*Engines which are certified to comply with California and U.S. EPA emission regulations for SORE (Small Off Road Equipment), are certified to operate on regular unleaded gasoline, and may include the following emission control systems: (EM) Engine Modification and (TWC) Three-way Catalyst (if so equipped).*

## Tecumseh Contact Information

Contact your nearest Authorized Tecumseh Servicing Dealer if:

- You are unable to perform service procedures covered in this handbook.
- You have questions about service procedures covered in this handbook.
- You would like to order service tools.
- You would like to request additional printed copies of this handbook.

You may find your Authorized Tecumseh Servicing Dealer on our website at [www.TecumsehPower.com](http://www.TecumsehPower.com) or call Tecumseh Power Company at 1-800-558-5402 or 262-377-2700 if you are located outside the U.S. or Canada.

# CONTENTS

<b>CHAPTER 1 GENERAL INFORMATION.....</b>	<b>1</b>
GENERAL SAFETY PRECAUTIONS .....	1
ENGINE IDENTIFICATION .....	3
OIL REQUIREMENTS.....	5
FUEL REQUIREMENTS .....	6
TUNE-UP PROCEDURE .....	7
STORAGE.....	8
<b>CHAPTER 2 AIR CLEANERS.....</b>	<b>9</b>
GENERAL INFORMATION .....	9
OPERATION .....	9
TROUBLESHOOTING .....	9
SERVICE.....	9
PAPER FILTER REMOVAL AND REPLACEMENT.....	10
POLYURETHANE FILTER REMOVAL AND SERVICE.....	10
<b>CHAPTER 3 CARBURETORS AND FUEL SYSTEMS .....</b>	<b>11</b>
GENERAL INFORMATION .....	11
OPERATION .....	11
FUEL PRIMERS.....	12
COMPONENTS.....	13
ENGINE TROUBLESHOOTING .....	16
TROUBLESHOOTING CARBURETION—TC/TM SERIES .....	17
TESTING.....	19
SERVICE.....	19
CARBURETOR PRE-SET AND ADJUSTMENT .....	19
CARBURETOR DISASSEMBLY .....	20
CARBURETOR INSPECTION .....	20
CARBURETOR ASSEMBLY .....	21
FUEL TANK SERVICE.....	24
<b>CHAPTER 4 GOVERNORS AND LINKAGE .....</b>	<b>25</b>
GENERAL INFORMATION .....	25
OPERATION .....	25
COMPONENTS.....	25
TROUBLESHOOTING .....	26
ENGINE OVERSPEEDING.....	26
ENGINE SURGING.....	26
SERVICE.....	26
GOVERNOR ADJUSTMENT .....	26
<b>CHAPTER 5 REWIND STARTERS.....</b>	<b>28</b>
GENERAL INFORMATION .....	28
OPERATION .....	28
TC TYPE I .....	28
TC TYPE II/TM .....	28
COMPONENTS.....	28
SERVICE.....	28
DISASSEMBLY PROCEDURE .....	28
ASSEMBLY PROCEDURE .....	29

<b>CHAPTER 6 IGNITION .....</b>	<b>30</b>
GENERAL INFORMATION .....	30
OPERATION .....	30
COMPONENTS.....	30
IGNITION TROUBLESHOOTING .....	31
TESTING.....	32
SERVICE.....	32
AIR GAP SETTING .....	32
SPARK PLUG SERVICE.....	32
 <b>CHAPTER 7 INTERNAL ENGINE AND CYLINDER .....</b>	 <b>33</b>
GENERAL INFORMATION .....	33
OPERATION .....	33
MANUAL COMPRESSION RELEASE .....	33
COMPONENTS.....	34
TROUBLESHOOTING .....	35-36
TESTING.....	37
ENGINE KNOCKS .....	37
ENGINE OVERHEATS .....	37
SURGES OR RUNS UNEVENLY .....	37
ENGINE MISFIRES.....	37
ENGINE VIBRATES EXCESSIVELY .....	38
LACKS POWER OR WILL NOT START.....	38
SERVICE.....	38
GENERAL INFORMATION .....	38
DISASSEMBLY PROCEDURE—TC TYPE 1 AND TC TYPE II .....	38-40
BEARING AND SEAL SERVICE—TC TYPE I AND TC TYPE II .....	40
ASSEMBLY—TC TYPE I AND TC TYPE II .....	41-43
DISASSEMBLY—TM .....	43-44
BEARING AND SEAL SERVICE—TM.....	44
ASSEMBLY—TM .....	45-47
 <b>CHAPTER 8 ENGINE SPECIFICATION AND SEARS CRAFTSMAN</b>	
<b>CROSS-REFERENCE .....</b>	<b>48</b>
TORQUE SPECIFICATIONS .....	48
ENGINE SPECIFICATIONS.....	49
SEARS CRAFTSMAN CROSS REFERENCE .....	50
 <b>CHAPTER 9 EDUCATIONAL MATERIALS AND TOOLS .....</b>	 <b>51-54</b>

# CHAPTER 1 GENERAL INFORMATION

## I. General Safety Precautions

### WARNING

Read the original equipment manufacturer's manual(s) and this handbook thoroughly before servicing Tecumseh engines.

Always follow recommended service procedures. Such procedures affect the safe operation of the equipment and the safety of you and/or the operator. Failure to follow the instructions and warnings may result in serious injury or death. Call Tecumseh Power Company at 1-800-558-5402 or visit [www.Tecumseh-Power.com](http://www.Tecumseh-Power.com) if you have any questions.

### A. Use Personal Protective Equipment

To avoid injury, wear protective equipment including appropriate clothing, eyewear, safety shoes and ear plugs when servicing Tecumseh products.

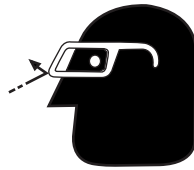

### B. Stay Away from Rotating Parts

Rotating parts can cause severe injury or death. Use special care when making service adjustments with covers or guards removed. Keep tools, hands, feet, hair, jewelry, and clothing away from all moving parts. Replace covers and guards before operating equipment.



### C. Stay Away from Hot Surfaces

Parts of equipment being serviced become extremely hot during operation and remain hot after the equipment has stopped. To avoid severe burns, stay away from hot surfaces or allow the unit to cool prior to service.



### D. Avoid Accidental Equipment Movement

To prevent accidental movement of equipment, always set the parking brake. For gear-driven products that do not have a parking brake, leave equipment in gear and chock the wheels. Refer to original equipment operator manuals for additional information.

Pulley bosses that hold the rewind spring inside the keeper and spring housing may not be secured and can be easily loosened. Use special care when handling this housing. Failure to do so could cause spring to "fly out" which could result in minor or moderate injury.

Always discard gaskets, O-rings and seals after removal. Use only new gaskets, O-rings and seals for assembly. Failure to do so could result in leakage from engine areas that use these parts.

### E. Always Provide Adequate Ventilation

To avoid serious injury or death, always ensure that you are working in a properly ventilated facility. Special precautions are required to avoid carbon monoxide poisoning. All engine exhaust contains carbon monoxide, a deadly gas. Breathing carbon monoxide can cause headaches, dizziness, drowsiness, nausea, confusion and eventually death. Carbon monoxide is a colorless, odorless, tasteless gas which may be present even if you do not see or smell any engine exhaust.

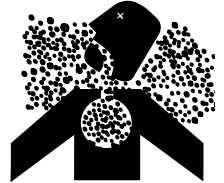

Deadly levels of carbon monoxide can collect rapidly and you can quickly be overcome and unable to save yourself. Also, deadly levels of carbon monoxide can linger for hours or days in enclosed or poorly-ventilated areas. If you experience any symptoms of carbon monoxide poisoning, leave the area immediately, get fresh air, and **SEEK MEDICAL TREATMENT.**

To prevent serious injury or death from carbon monoxide:

- ALWAYS direct engine exhaust outdoors.
- NEVER run engine outdoors where engine exhaust can be drawn into a building through openings such as windows and doors.

### F. Use Proper Methods When Cleaning

To reduce the risk of serious injury or death from fires and/or explosions, NEVER use flammable solvents (e.g., gasoline) to clean serviceable parts. Use a water-based, non-flammable solvent such as Tecumseh Degreaser Cleaner.



### G. Compressed Air Precautions

Never use compressed air to clean debris from yourself or your clothing. When using compressed air to clean or dry serviceable parts:

- Wear appropriate eye protection.
- Use only approved air blow nozzles.
- Air pressure must not exceed 30psi (206kPa).
- Shield yourself and bystanders from flying debris.

### H. Inspect and Adjust Brake(s)

Always inspect and adjust flywheel brake components whenever servicing equipment that has a Tecumseh engine. Refer to this Technician's Handbook and bulletins for proper brake adjustment.

## I. Operate Equipment Safely

Operation of equipment presented for service can be hazardous. To avoid serious injury or death, DO NOT operate equipment, until:

- all relevant inspection procedures presented in this handbook are performed and
- technician is satisfied equipment can be operated safely.
- Starter pulley springs hold the starter rope and control tension by winding the rope around the pulley. Use caution when pulling and releasing the rope to and from the starter housing. Failure to do so could cause the rope to unexpectedly jerk back which could result in minor or moderate injury.

## J. Avoid Gasoline Fires

Gasoline (fuel) vapors are highly flammable and can explode. Fuel vapors can spread and be ignited by a spark or flame many feet away from engine. To prevent injury or death from fuel fires, follow these instructions:



- NEVER store engine with fuel in fuel tank inside a building with potential sources of ignition such as hot water and space heaters, clothes dryers, electric motors, etc.
- NEVER remove fuel cap or add fuel when engine is running.
- NEVER start or operate the engine with the fuel fill cap removed.
- Allow engine to cool before refueling.
- NEVER fill fuel tank indoors. Fill fuel tank outdoors in a well-ventilated area.
- DO NOT smoke while refueling tank.
- DO NOT pour fuel from engine or siphon fuel by mouth.

## K. Avoid Accidental Starts

To prevent accidental starting when working on equipment always:

- Disconnect spark plug wire and keep it away from spark plug.
  - Keep the disconnected spark plug wire securely away from metal parts where arcing could occur.
  - Attach the spark plug wire to the grounding post, if provided.
- Turn off all engine switches.

# ENGINE IDENTIFICATION

## Engine Model Families

This Tecumseh Technician's Handbook covers the following engine model types:

- TC200 - Two Cycle Engine Type I - 2.0 cubic inch displacement.
- TC300 - Two Cycle Engine Type II - 3.0 cubic inch displacement.
- TM049XA- Two Cycle Engine Multi Position - 49cc displacement.

*The letter designations in a model number indicate the basic type of engine. See diag. 1-4.*

*The number designations following the letters indicate the basic engine model.*

*The number following the model number is the specification number. The last three numbers of the specification number indicate a variation to the basic engine specification.*

*The serial number or D.O.M. indicates the production date of the engine.*

TC engine identification numbers are stamped into the blower housing or blower housing base near the spark plug, or a decal is permanently attached to the side of the blower housing. See diag. 1-1.

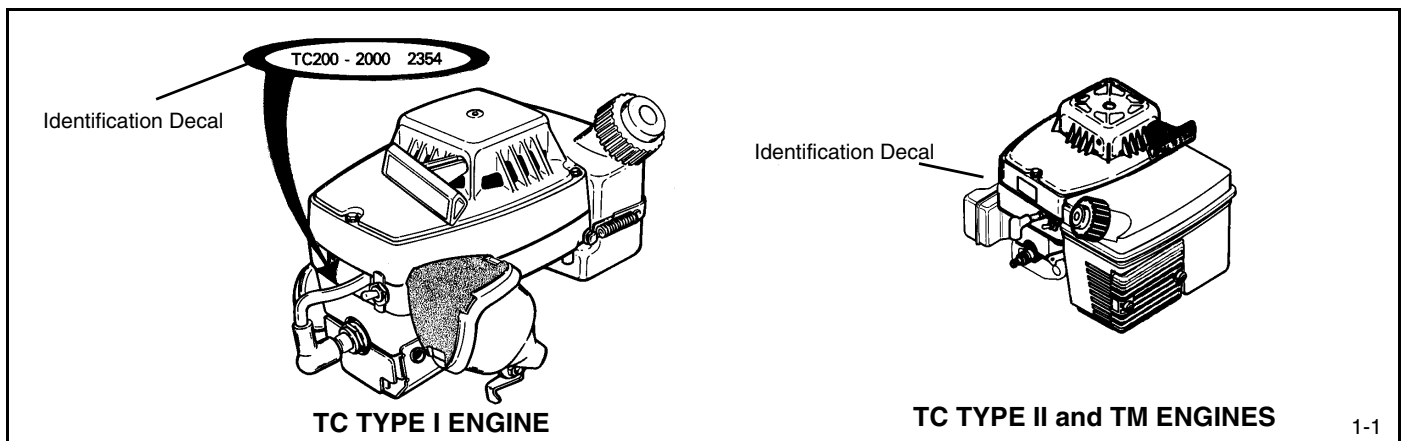

The engine identification decal will include the model number, engine type, warranty code, and date of manufacture. See diag. 1-2 and 1-3.

The model number designation following TC (Tecumseh Compact) indicate the cubic inch displacement of the engine. TC300 indicates a 3.0 cubic inch displacement.

The number (3133C) following the model number is the specification number. The last two numbers and letter character (33C) indicate a variation to the basic engine specification.

The warranty number letter (B) indicates the length of warranty that is supplied by Tecumseh.

The DOM (Date of Manufacture) or Serial Number indicate the date the engine was produced. The first digit (5) is the year in the decade (1995). The next three digits (114) indicate the build date (114th day of the year or April 24). The letter designation indicates the line or shift on which the engine was built at the factory.

Short blocks are identified by a tag marked SBH (Short Block Horizontal) or SBV (Short Block Vertical). See diag. 1-5.

## I. TC200 Models

A sample **TC200** decal is pictured for reference. See diag. 1-2.

Using model **TC200-2015B 2354D** as an example, interpretation is as follows: See Table 1-1.

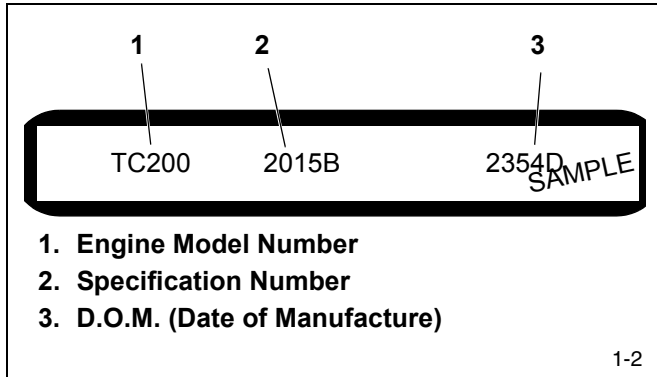

Sample TC200 Decal

## II. TC300 Models

A sample **TC300** decal is pictured for reference. See diag. 1-3.

Using model **TC300-3133C(B)5114G** as an example, interpretation is as follows: See Table 1-2.

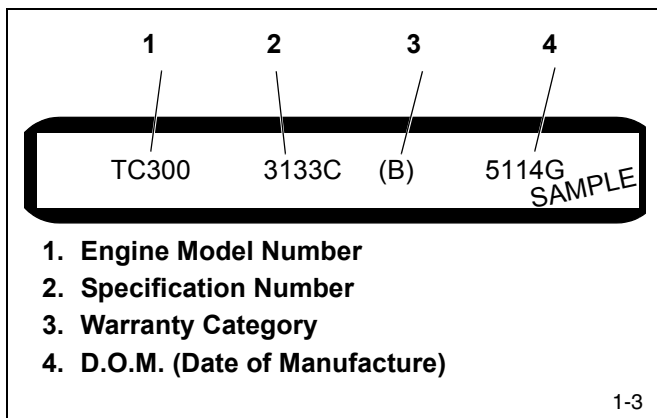

Sample TC300 Decal

Table 1-1. TC200 Engine Model Code Designations

Code	Model Number
T	Indicates Tecumseh Engine Manufacturer.
C	Indicates compact model.
<b>200</b>	Indicates 2.0 cubic inch displacement.
Code	Specification Number
2015B	Indicates number used for identifying the parts of the engine.
Code	Serial/D.O.M. Designation
2	Is the last digit in the year of manufacture (1992).
354	Indicates the calendar day of that year (354th day or December 20).
D	Indicates the plant line and shift on which the engine was built at the factory.

Table 1-2. TC300 Engine Model Code Designations

Code	Model Number
T	Indicates Tecumseh Engine Manufacturer.
C	Indicates compact model.
<b>300</b>	Indicates 3.0 cubic inch displacement.
Code	Specification Number
3133C	Indicates number used for identifying the parts of the engine.
Code	Warranty Code
B	Indicates Warranty Information. See current Operator's Manual for information.
Code	Serial/D.O.M. Designation
5	Is the last digit in the year of manufacture (1995).
114	Indicates the calendar day of that year (114th day or April 24).
G	Indicates the plant line and shift on which the engine was built at the factory.



### III. TM Models

A sample **TM** decal is pictured for reference.

See diag. 1-4.

Using model **TM049XA 3617B A 4056CA** as an example, interpretation is as follows: See Table 1-3.

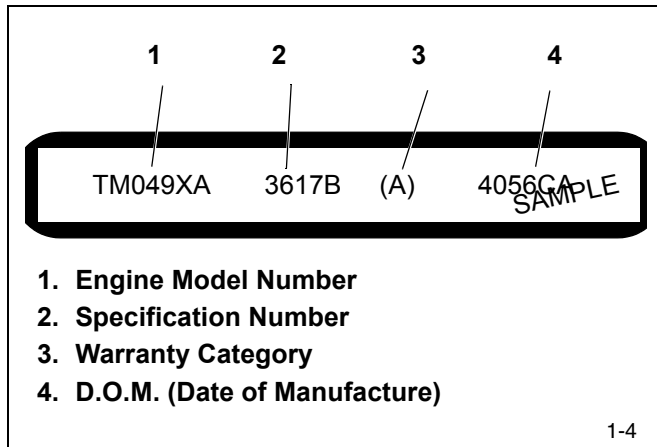

**Sample TM Decal**

**Table 1-3. TM Engine Model Code Designations**

Code	Model Number
T	Indicates two cycle model.
M	Indicates multi position model.
049	Indicates Displacement-49cc
X	Is <b>49</b> State/Global Emissions Compliant.
A	Indicates standard Model.
Code	Specification Number
<b>3617B</b>	Indicates specification number used for identifying the parts of the engine.
Code	Warranty Code
A	Indicates Warranty Information. See current Operator's Manual for details.
Code	Serial/D.O.M. Designation
4056CA	Is the serial number or D.O.M. (Date of Manufacture).
4	Is the last digit in the year of manufacture (2004).
056	Indicates the calendar day of that year (56th day or February 25).
C	Indicates the plant line and shift on which the engine was built at the factory.
A	Indicates the location of where the engine was built at the factory.

### Short Blocks

New short blocks are identified by a tag marked SBH (Short Block Horizontal) or SBV (Short Block Vertical). Original model identification numbers of an engine should always be transferred to a new short block for correct parts identification. See diag. 1-5.

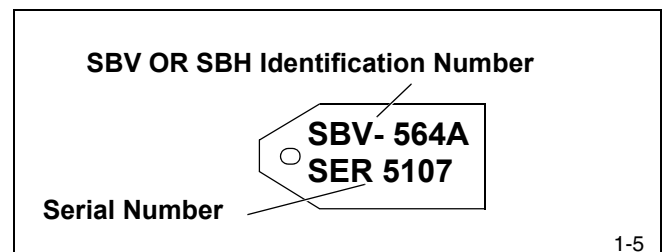

**Short Block Identification Tag**

## OIL REQUIREMENTS

Tecumseh recommends using two-cycle oil part # 730227C, which is a synthetic blend that ensures cylinder wall lubrication, mixes easy, and does not separate. Two cycle oil part # 730227C is specially formulated for use in air or water cooled two cycle engines and contains an added fuel stabilizer.

Tecumseh two cycle engines require the use of a NMMA TC-W3 or TC-WII certified oil.

The proper fuel mixture ratio of oil to gasoline for specific engines will be found in the Operator's Manual and on the decal attached to the blower housing or fuel tank of the engine.

## FUEL REQUIREMENTS

Tecumseh Power Company strongly recommends the use of fresh, clean, unleaded regular gasoline in all Tecumseh engines. Unleaded gasoline burns cleaner, extends engine life, and promotes good starting by reducing the build-up of combustion chamber deposits. Leaded gasoline, gasohol containing no more than 10% ethanol, premium gasoline, or unleaded gasoline containing no more than 15% MTBE (Methyl Tertiary Butyl Ether), 15% ETBE (Ethyl Tertiary Butyl Ether) or 10% ethanol, can be used if unleaded regular gasoline is not available.

Reformulated gasoline that is now required in several areas of the United States is also acceptable.

**NEVER USE:** gasoline, fuel conditioners, additives or stabilizers containing methanol. The use of white gas, gasohol containing more than 10% ethanol, unleaded regular gasoline containing more than 15% MTBE (Methyl Tertiary Butyl Ether), 15% ETBE (Ethyl Tertiary Butyl Ether) or 10% ethanol is not recommended as engine/fuel system damage could result.

See "STORAGE" instructions in Technician's Manual, Operator's Manual, or Bulletin 111.

Tecumseh two-cycle oil part # 730227C contains a fuel stabilizer for year round fuel stability in and out of season. If oil other than Tecumseh two cycle is used, use Tecumseh's fuel stabilizer part # 730245.

### MIXING FUEL AND OIL

**WARNING** NEVER store engine with fuel in fuel tank inside a building with potential sources of ignition such as hot water and space heaters, clothes dryers, electric motors, etc.

DO NOT mix fuel and oil directly in fuel tank.

Use of NMMA, TC-WII or TC-W3, JASO FB or JASO FC classified oil is recommended.

1. Be sure container is outdoors and in a well-ventilated area.
2. Fill approved clean red GASOLINE container with 1/4 of recommended fuel amount. See Table 1-4 and Table 1-5.
3. Add required amount of recommended oil to fuel. See Table 1-4.
4. Screw cap onto container.
5. Shake container vigorously.
6. Unscrew cap from container.
7. Fill container with remainder of recommended fuel. See Table 1-4 and Table 1-5.
8. Wipe away any spilled fuel or oil.

### FUEL ADDITIVES

Only fuel additives such as Tecumseh's fuel stabilizer part # 730245A or liquid varieties can be used when mixed properly. **For winter applications, Isopropyl alcohol** fuel dryers may be used in the fuel system but must be mixed at the proper ratio recommended by the manufacturer. **NEVER USE METHANOL BASED DRYERS.**

Gasoline and oil containers must be clean, covered, and rust-free. Old gas or fuel contamination can restrict or block fuel filters, and small fuel ports and passages in the carburetor. If the engine is to be unused for 30 days or more see "Storage" for fuel system instructions.

**Table 1-4. Fuel Mix Chart — Mixture Ratio 24:1**

U.S.		S.I. Metric	
Gas	Oil	Petrol	Oil
1 Gal.	5 oz.	4 Liters	167 ml
2 Gal.	11 oz.	8 Liters	333 ml
5 Gal.	27 oz.	20 Liters	833 ml

**Table 1-5. Recommended Fuel**

Fuel Component	Percentage
Ethanol	10%
Grain Alcohol ("Gasohol")	10%
MTBE (Methyl Tertiary Butyl Ether)	15%
ETBE (Ethyl Tertiary Butyl Ether)	15%

## TUNE-UP PROCEDURE

The following is a minor tune-up procedure. If the engine does not perform properly after the tune-up is completed, consult the "Troubleshooting Engine Operation Chart" found in Chapter 7. Repair procedures are listed in each chapter.

### CAUTION

Remove the spark plug wire before doing any service work on the engine.

1. Service or replace the air cleaner as necessary. Use the applicable procedure found in Chapter 2 under "Service".
2. Remove the fuel from the fuel tank by running the engine until stopping or draining into an approved fuel container.
3. Remove the fuel tank and blower housing to clean all debris from the air intake screen, cylinder cooling fins, governor and carburetor linkage.
4. Replace the blower housing and check all remote linkage for proper adjustment and operation.
5. Check to see that the engine is properly secured to the equipment. On rotary lawnmowers, balance the blade and check the blade hub and crankshaft key for wear. Replace as necessary. Torque the bolts to the correct specification.
6. Replace the spark plug with the correct replacement by using the Master Parts Manual. Set the spark plug gap at .030" (.762 mm) and install it in the engine. Tighten the spark plug to 230 inch pounds (2.6 Nm) of torque. If a torque wrench isn't available, screw the spark plug in as far as possible by hand. Use a spark plug socket or wrench to turn the spark plug 1/8 to 1/4 turn further if using the old spark plug, or 1/2 turn further if a new spark plug is used. Reinstall the spark plug wire.
7. Fill the fuel tank with the proper fuel/oil mix.
8. Start the engine and allow it run 3 - 5 minutes to reach operating temperature. Adjust the carburetor if necessary (see Chapter 3 under "Service" for the final idle mixture adjustment procedure) and set the engine R.P.M.(s) according to the specification number found on microfiche card # 30 or computer parts lookup system.

## **STORAGE** (IF THE ENGINE IS TO BE UNUSED FOR 30 DAYS OR MORE.)

### **⚠ WARNING**

Never store the engine with fuel in the fuel tank inside a building with potential sources of ignition such as hot water or space heaters, clothes dryers, electric motors, etc.

Gasoline can become unstable in less than 30 days and form deposits that can impede proper fuel flow and engine operation. To prevent deposits from forming, all gasoline must be removed from the fuel tank and the carburetor. An acceptable alternative to removing all gasoline is adding a fuel stabilizer to the gasoline such as Tecumseh part # 730245A. A fuel stabilizer is added to the fuel tank or storage container. Always follow the mix ratio and mixing procedure found on the stabilizer container. Run the engine at least 10 minutes after adding the stabilizer to allow it to reach the carburetor.

### **Draining The Fuel System**

1. Remove all gasoline from the fuel tank by running the engine until the engine stops, or by draining the fuel tank by removing the fuel line at the carburetor. Be careful not to damage the fuel line or the carburetor fitting. Drain the fuel into an approved container outdoors, and away from any open flame or combustible source. Be sure the engine is cool.

### **⚠ WARNING**

To avoid death or serious injury, DO NOT pour fuel from engine or siphon fuel by mouth.

2. If "Gasohol" has been used, complete the above procedure and then put 2 ounces (60 ml) of the recommended fuel / oil mixture using regular unleaded gasoline into the fuel tank. Run the engine until it stops due to a lack of fuel. If "Gasohol" is allowed to remain in the fuel system during storage, the alcohol content may cause gaskets and seals to deteriorate.

### **Oil Cylinder Bore**

1. Remove the spark plug wire from the spark plug. Pull the starter handle slowly until resistance is felt due to compression pressure, then stop. Slowly release starter tension to prevent the engine from reversing due to compression pressure.
2. Remove the spark plug, squirt 1/2 ounce (15 ml.) of clean 2-cycle engine oil into the spark plug hole.
3. Cover the spark plug hole with a shop towel and crank the engine over, slowly, several times.
4. Replace the spark plug and tighten (see step # 6 under Tune-Up Procedure for proper spark plug torque). Pull the starter handle as performed in step # 1. The piston position blocks the cylinder ports, preventing atmospheric air from entering and oil from leaving the cylinder bore during storage.
5. Replace the spark plug wire on the spark plug.

# CHAPTER 2 AIR CLEANERS

## GENERAL INFORMATION

The air cleaner is designed to eliminate dust and dirt from the air supply. Most models of 2-cycle and 4-cycle engines use an air cleaner except engines that run in clean environments like snow throwers or ice augers. On these applications, a filter is not necessary and could collect snow or moisture and prevent proper engine operation. On most applications, filtered air is necessary to assure abrasive particles are removed before entering the combustion chamber. Dirt allowed into the engine will quickly wear the internal components and shorten the life of the engine.

Tecumseh engines use either a polyurethane or a paper type air filter system. A polyurethane pre-filter or a flocked screen may be used in conjunction with the main filter. Extremely dirty operating conditions may require frequent filter cleaning or replacement.

## OPERATION

The outer cover holds the air filter element(s) and prevents debris from entering the filter box. The air supply is filtered through the pre-filter if equipped, filter element (polyurethane or paper), and a flocked screen if equipped. Pre-filter elements do not extend the recommended air filter service intervals listed under "Service". However; in extremely dirty operating conditions a pre-filter element may increase the run time of the engine before the filter becomes restricted (not to exceed the service recommendations), and service on the filter is necessary.

## TROUBLESHOOTING

If the engine's performance is unsatisfactory (needs excessive adjustments, starts smoking abnormally, loses power), the first component to be checked is the air cleaner. A dirt restricted or an oil soaked filter element will cause noticeable performance problems. A polyurethane element may be cleaned following the service procedure listed under "Service" in this chapter. A paper-type air filter should only be replaced. Follow the procedure listed in the service section in this chapter for replacement. Retry the engine after filter replacement or service. If the problem persists after filter service, additional solutions can be found in Chapter 7 under "Troubleshooting".

## SERVICE

Cleaning and oiling the polyurethane element (diag. 2-1) is recommended every three (3) months or every 25 operating hours. If the engine is used in extremely dusty or dirty conditions, the filter may require service every three hours or as often as necessary to maintain proper engine performance.

Polyurethane type filters require re-oiling after extended storage due to oil migration out of the filter.

A paper type element (diag. 2-2) should be replaced once a year, every 100 operating hours, or more often if used in extremely dusty conditions. Use only original factory recommended replacement filters.

### NOTE

*DO NOT attempt to clean or oil paper filters.*

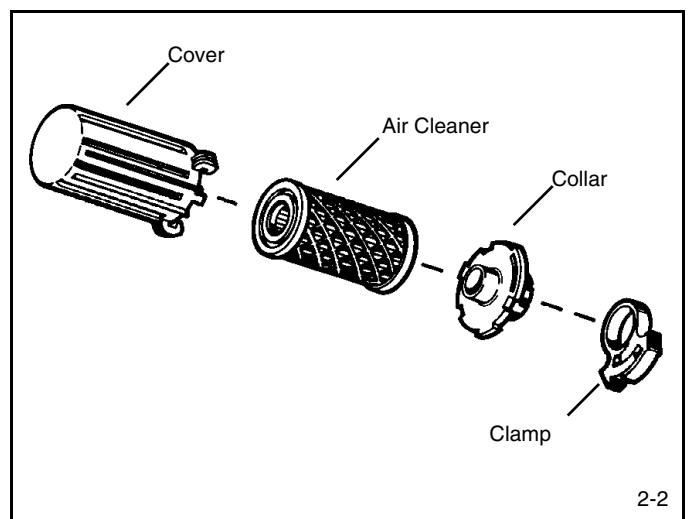
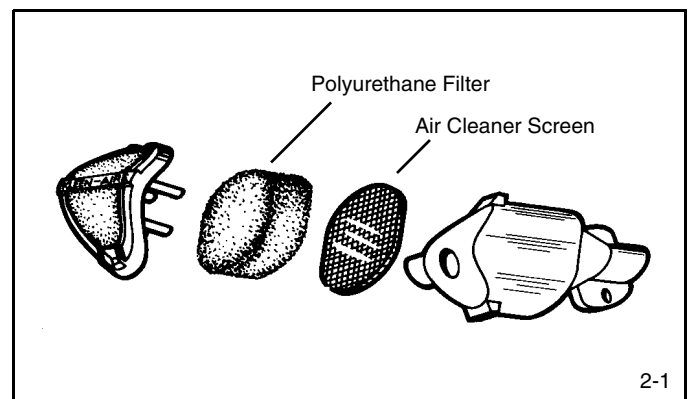

## Paper Filter Removal and Replacement

1. Remove the polyurethane pre-filter (if equipped) from the air filter.
2. Inspect the filter(s) for discoloration or dirt accumulation. (For the polyurethane pre-cleaner service see step # 5 under "Polyurethane Filter Removal and Service"). If either condition is present, replace the paper type filter using the following steps.
3. Loosen the clamp and slide the clamp toward the air filter (diag. 2-3).
4. Slide the air filter and clamp off the carburetor adapter. Discard the old filter and keep the clamp.
5. Apply a thin layer of silicon sealant to the outside of the air cleaner adapter.
6. Install the clamp on the new air filter, slide the filter assembly onto the carburetor adapter as far as it will go.
7. Slide the clamp as close to the carburetor as possible. Tighten the clamp securely.

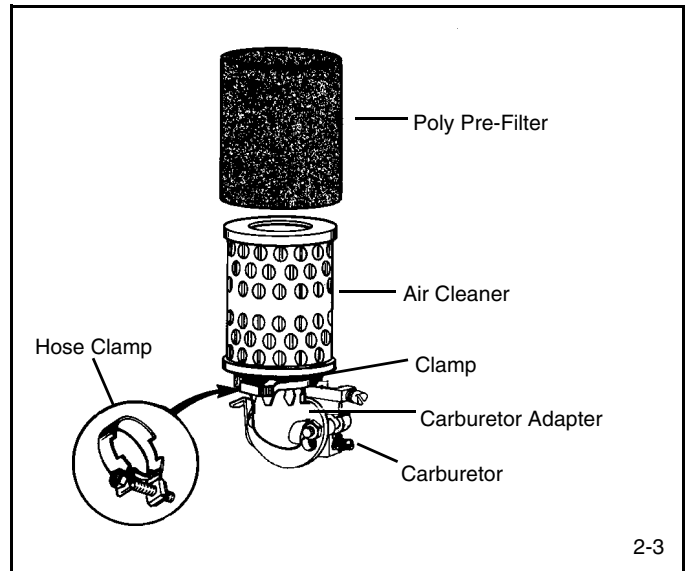

## Polyurethane Filter Removal and Service

### Kleen Aire® Air Cleaner, TC Type II or TM

1. Remove the cover by pulling outward on the tab (diag. 2-4). On the TC Type II/TM style engine, loosen the two screws (diag. 2-5).
2. Remove screen A (if equipped), foam filter and screen B from the air cleaner body (diag. 2-4). On TC Type II/TM engines, remove the flocked screen and the foam filter (diag. 2-5).
3. Inspect the flocked screen and foam filter for discoloration or dirt accumulation. If either condition is present, service the element or screen using the following steps.
4. The flocked screen pre-filter may be cleaned by blowing compressed air through the screen from the back side. Replace the screen if this procedure does not fully remove the accumulated particles.
5. Wash the polyurethane filter or polyurethane pre-filter (used with paper air filters) in a detergent water solution and squeeze (don't twist) until all dirt is removed.
6. Rinse the polyurethane filter or polyurethane pre-filter thoroughly in clean water. Wrap the filter in a clean cloth and squeeze (don't twist) until completely dry.
7. Reassemble the filter assemblies per the illustrations.

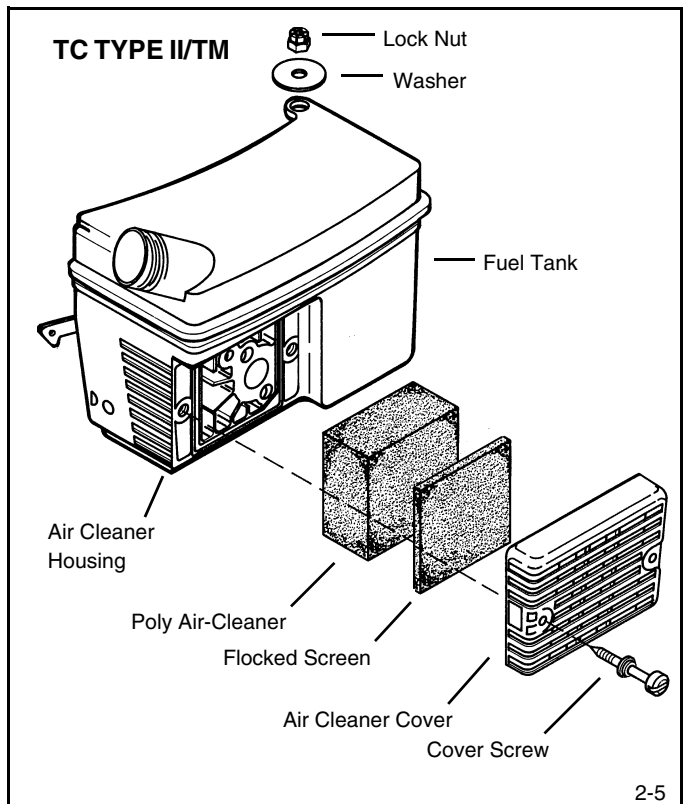
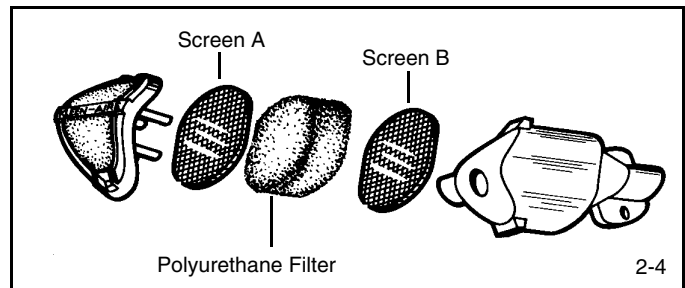

# CHAPTER 3 CARBURETORS AND FUEL SYSTEMS

## GENERAL INFORMATION

TC/TM engines almost exclusively use diaphragm-type carburetors to be able to run effectively at any operating angle. The diaphragm carburetors are produced by Tecumseh, Walbro and Tillotson for Tecumseh. The carburetors use an internal diaphragm fuel pump to supply the fuel to the carburetor fuel metering chamber. The metering diaphragm has one side exposed to intake manifold pressure and one side exposed to atmospheric pressure. This diaphragm provides the same basic function (maintaining the proper fuel level in the carburetor) as the float.

A limited number of TC engines were produced as outboards using a Tecumseh Series II float style carburetor. Consult the Two Cycle Technician's Handbook (part # 692508) if service is required on this series of carburetor.

When servicing carburetors, use the engine model and specification number to obtain the correct carburetor part number. An alternate method to find the correct carburetor part number is to use the manufacturing number and date code stamped on the carburetor and convert this number to a part number. In the carburetor section of the Master Parts Manual, Microfiche Catalog, or Electronic Parts Catalog, a cross reference chart will convert a carburetor manufacturing number to a Tecumseh part number. When using computer parts look up system, it is only necessary to enter this information in the search box using prefix OK for Tecumseh carburetors, WA or WTA for Walbro carburetors or HU for Tillotson carburetors (diag. 3-1).

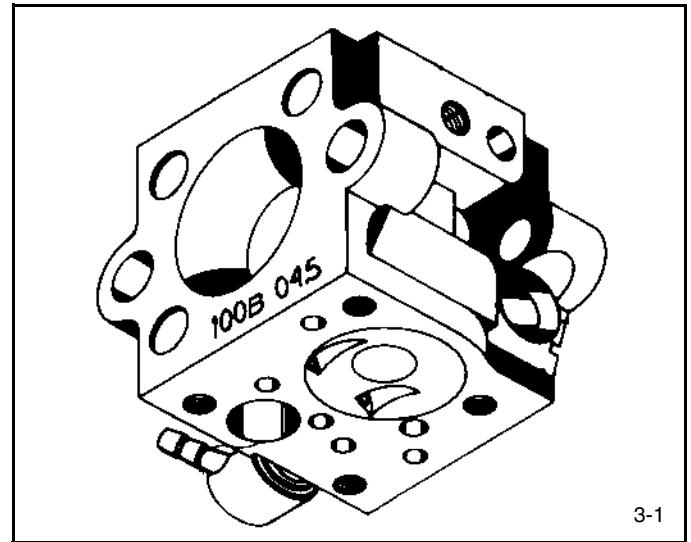

## OPERATION

In the "CHOKE" or "START" position, the choke shutter is closed, and the only air entering the engine flows through openings around the choke shutter. As the recoil assembly is operated to start the engine, upward piston travel creates a low pressure area in the crankcase. High pressure atmospheric air rushes into the crankcase to fill the created low pressure area. Since the majority of the air passage is blocked by the choke shutter, a relatively small quantity of air enters the carburetor at increased speed. The main nozzle and both idle fuel discharge ports are supplying fuel due to the low air pressure in the intake of the engine and the fuel side of the main diaphragm. Atmospheric air pressure on the opposite side of the main diaphragm forces the diaphragm upward, depressing the inlet control lever, overcoming inlet spring pressure and allowing fuel to enter the fuel chamber through the inlet valve. A maximum fuel flow through the carburetor orifices combined with the reduced quantity of air that passes through the carburetor, make a very rich fuel mixture which is needed to start a cold engine (diag. 3-2).

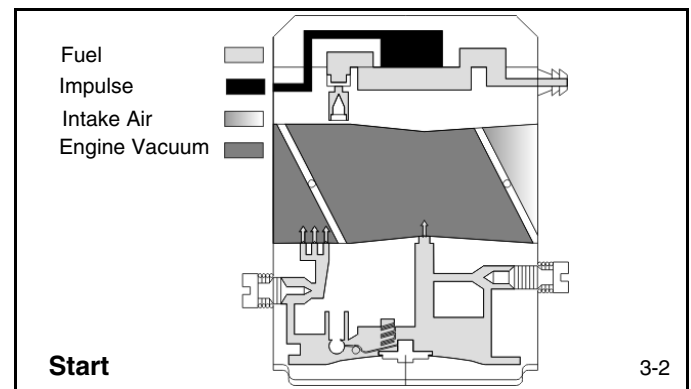

At IDLE the throttle shutter is almost closed, the low pressure acts only on the primary idle fuel discharge port due to throttle plate position. A relatively small quantity of fuel is needed to operate the engine (diag. 3-3).

During INTERMEDIATE throttle operation, the secondary idle fuel discharge port supplies fuel after it is uncovered by the throttle plate. As the throttle plate opens progressively further, engine speed increases. The velocity of air going through the carburetor venturi creates a low pressure area to develop at the main fuel discharge port while diminishing the effect of the low pressure area on the engine side of the throttle plate. When the pressure at the venturi throat is less than that existing within the fuel chamber, fuel is forced through the high speed mixture orifice and out the main fuel discharge port (diag. 3-4).

At HIGH SPEED operation, the throttle shutter is in a full open position. The air velocity through the venturi increases which further lowers the air pressure at the main fuel discharge port. All discharge ports are supplying fuel as the adjustment orifices will allow (diag. 3-5).

The fuel pump diaphragm in the carburetor moves up and down by pressure changes (pulsations) caused by piston movement. The pulsations are transferred to the pump by a passage called the impulse channel. The pump diaphragm moves up drawing fuel into the pump fuel chamber during a positive pulse, and a negative pulse moves the diaphragm down forcing fuel out of the fuel chamber through the inlet needle into the metering chamber.

## FUEL PRIMERS

Primers used on TC/TM engines supply a solid fuel charge to the carburetor main nozzle (diag. 3-6). Fuel is forced directly into the carburetor venturi. A choke shaft and shutter is not needed or used when a primer is used. This charge of fuel provides the rich mixture necessary to start the engine.

Below the main nozzle is a one way check valve to prevent fuel from being drawn back into the fuel chamber when the primer bulb is released. The check valve also prevents air from entering the carburetor during normal engine operation.

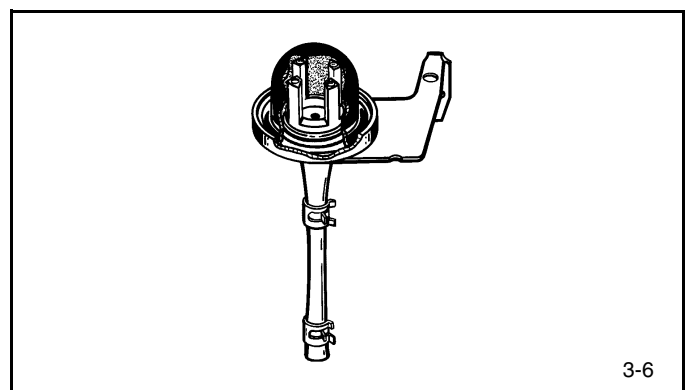
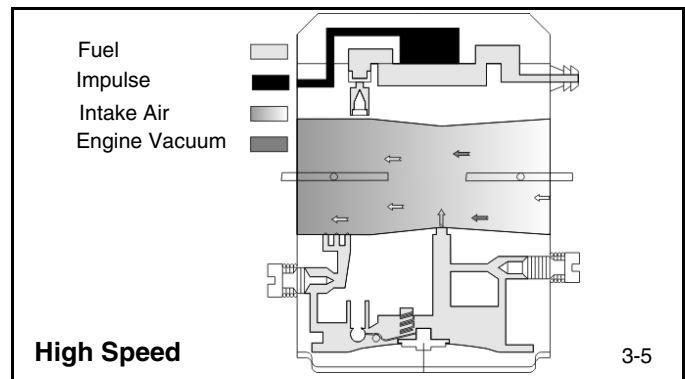
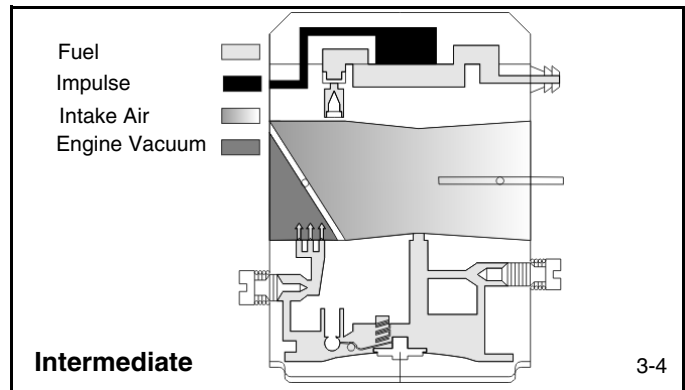
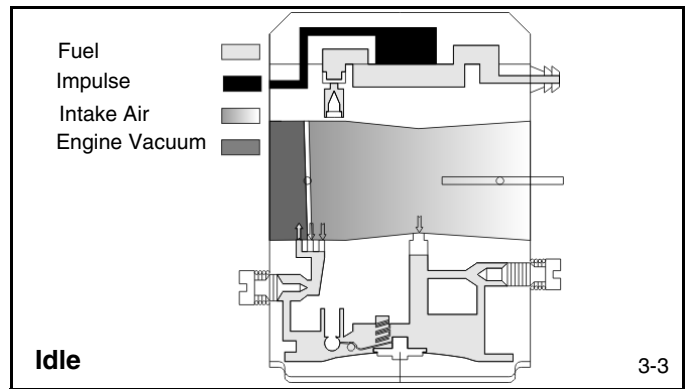



# COMPONENTS

## WALBRO CARBURETOR

1. Diaphragm Cover Screw
2. Metering Diaphragm Cover
3. Diaphragm
4. Diaphragm Gasket
5. Metering Lever
6. Metering Lever Screw
7. Metering Lever Pin
8. Metering Lever Spring
9. Inlet Valve Needle
10. Inlet Valve Seat
11. Welch Plug- 12. Choke Shaft
- 13. Choke Shutter Screw
- 14. Choke Shutter
- 15. Idle Mixture Screw
- 16. Idle Speed Screw
- 17. Throttle Shaft
- 18. Throttle Shaft Return Spring
- 19. Throttle Shutter Screw
- 20. Throttle Shutter
- 21. Fuel Fitting
- 22. Fuel Inlet Screen
- 23. Pump Diaphragm
- 24. Pump Cover Gasket
- 25. Pump Cover
- 26. Pump Cover Screw
- 27. Tension Spring
- 28. Dust Seal
- 29. Dust Seal Washer

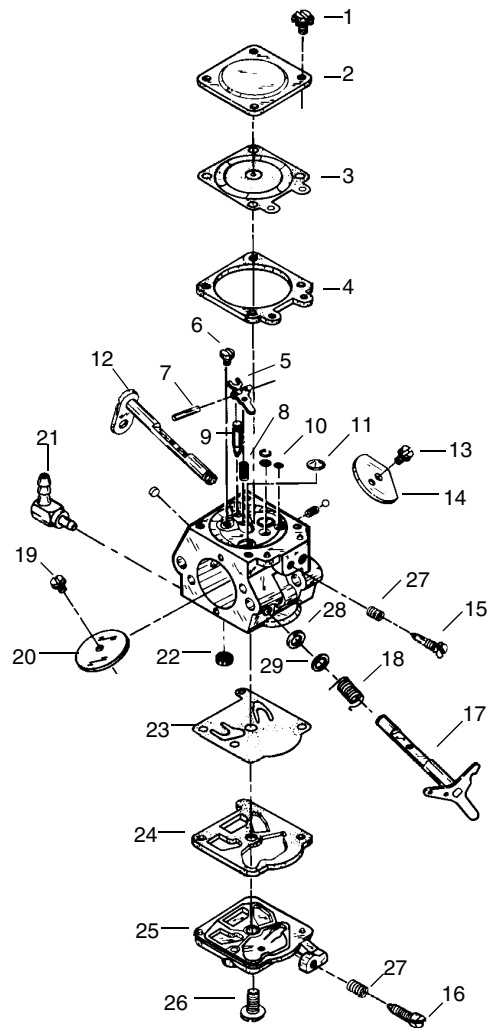

# TILLOTSON CARBURETOR

1. Diaphragm Cover Screw
2. Metering Diaphragm Cover
3. Diaphragm
4. Diaphragm Gasket
5. Metering Lever
6. Metering Lever Screw
7. Metering Lever Pin
8. Metering Lever Spring
9. Inlet Valve Needle
10. Air Vane
11. Air Vane Screw
12. Dust Seal
13. Dust Seal Washer
14. Dust Seal Retainer
15. Idle Mixture Screw
16. Idle Speed Screw
17. Throttle Shaft
18. Throttle Shaft Return Spring
19. Throttle Shutter Screw
20. Throttle Shutter
21. Fuel Fitting
22. Fuel Inlet Screen
23. Pump Diaphragm
24. Pump Cover Gasket
25. Pump Cover
26. Pump Cover Screw
27. Tension Spring
28. Main Mixture Jet
29. Welch Plug

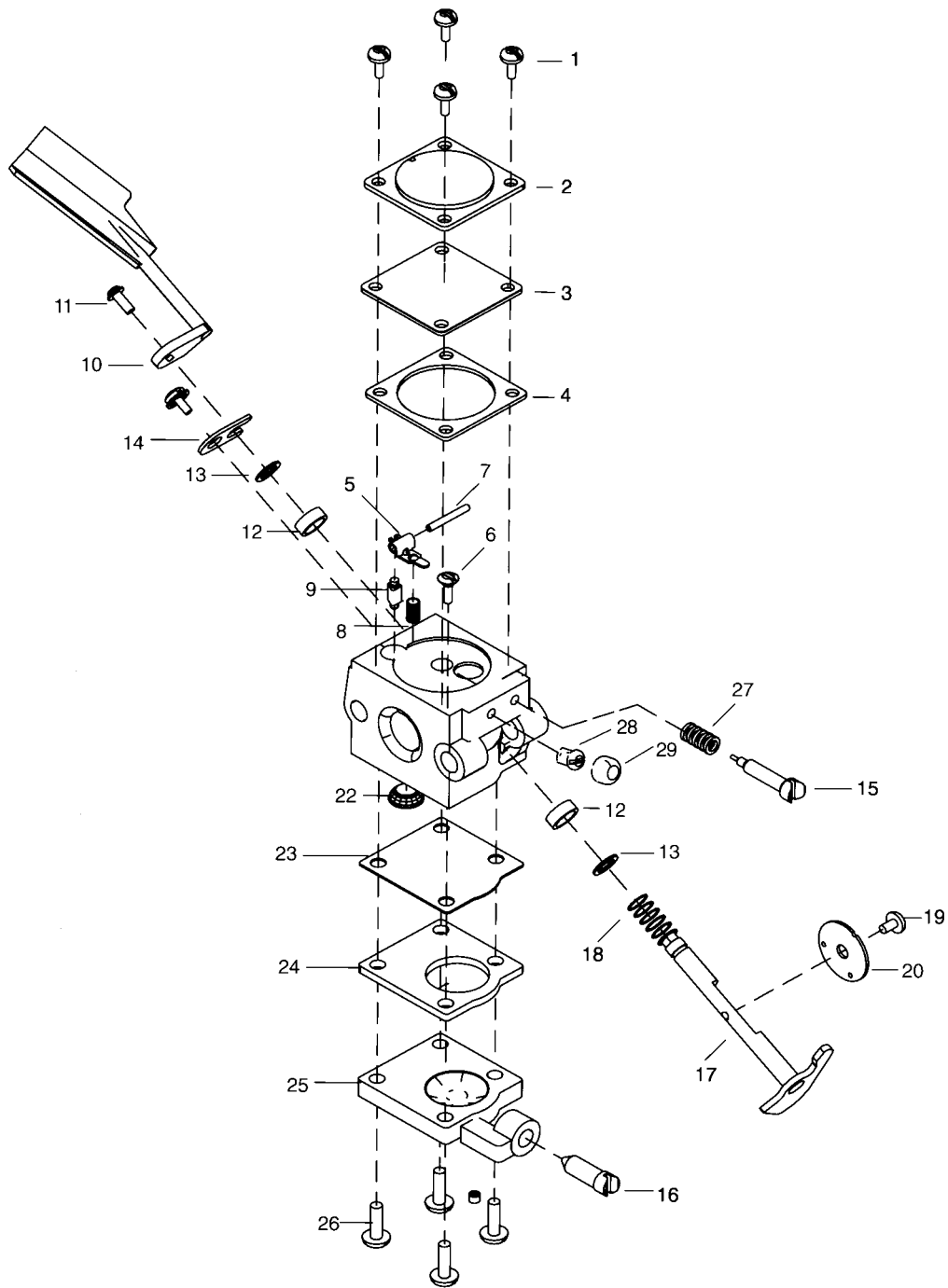

## TECUMSEH CARBURETOR

1. Diaphragm Cover Screw
2. Metering Diaphragm Cover
3. Diaphragm
4. Diaphragm Gasket
5. Metering Lever Screw
6. Metering Lever Pin
7. Inlet Valve Needle
8. Metering Lever
9. Metering Lever Spring
10. Welch Plug
11. Dust Seal
12. Dust Seal Retainer
13. Dust Seal Retainer Screw
14. Idle Mixture Screw
15. Welch Plug
16. Dust Seal
17. Dust Seal Washer
18. Throttle Shaft Return Spring
19. Throttle Shutter Screw
20. Throttle Shutter
21. Fuel Fitting
22. Pump Diaphragm
23. Pump Cover Gasket
24. Pump Cover
25. Pump Cover Screw
26. Idle Speed Screw
27. Throttle Shaft

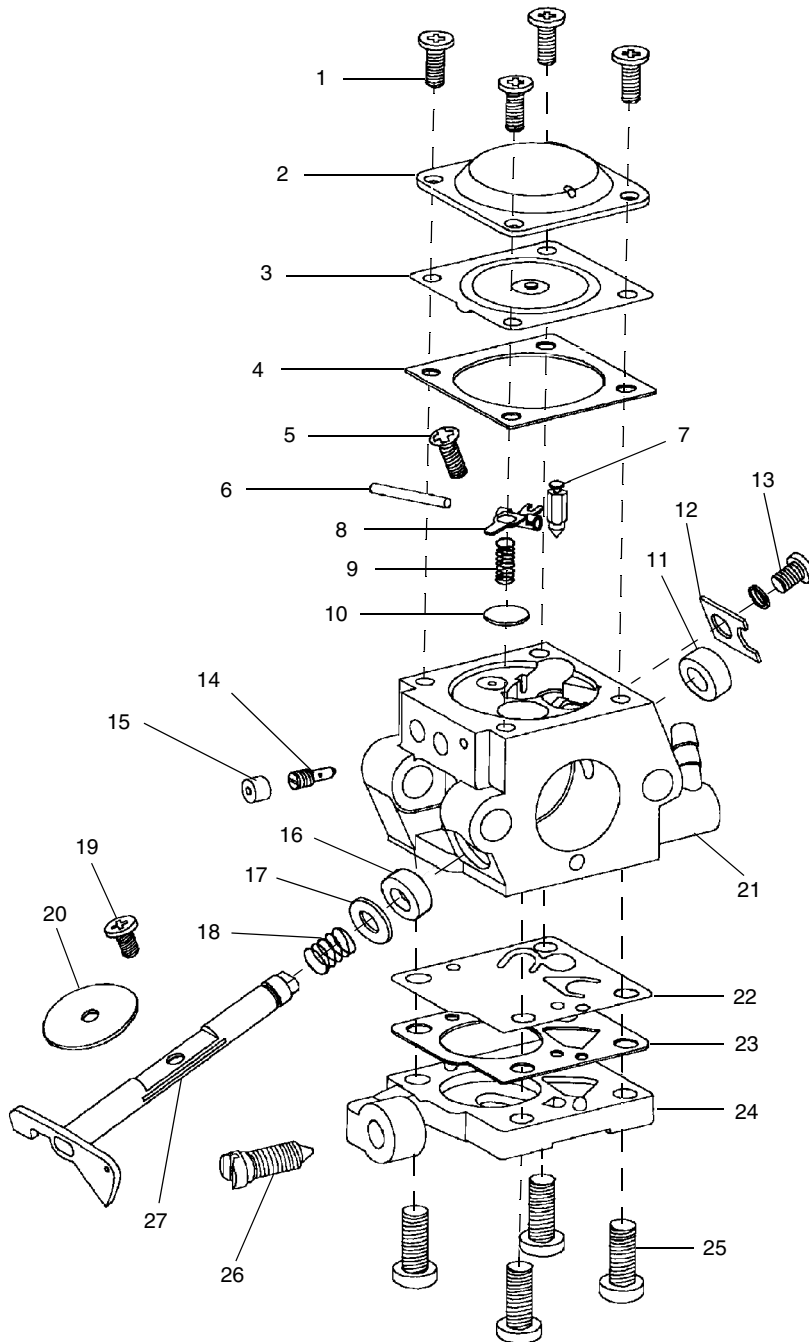

# ENGINE TROUBLESHOOTING

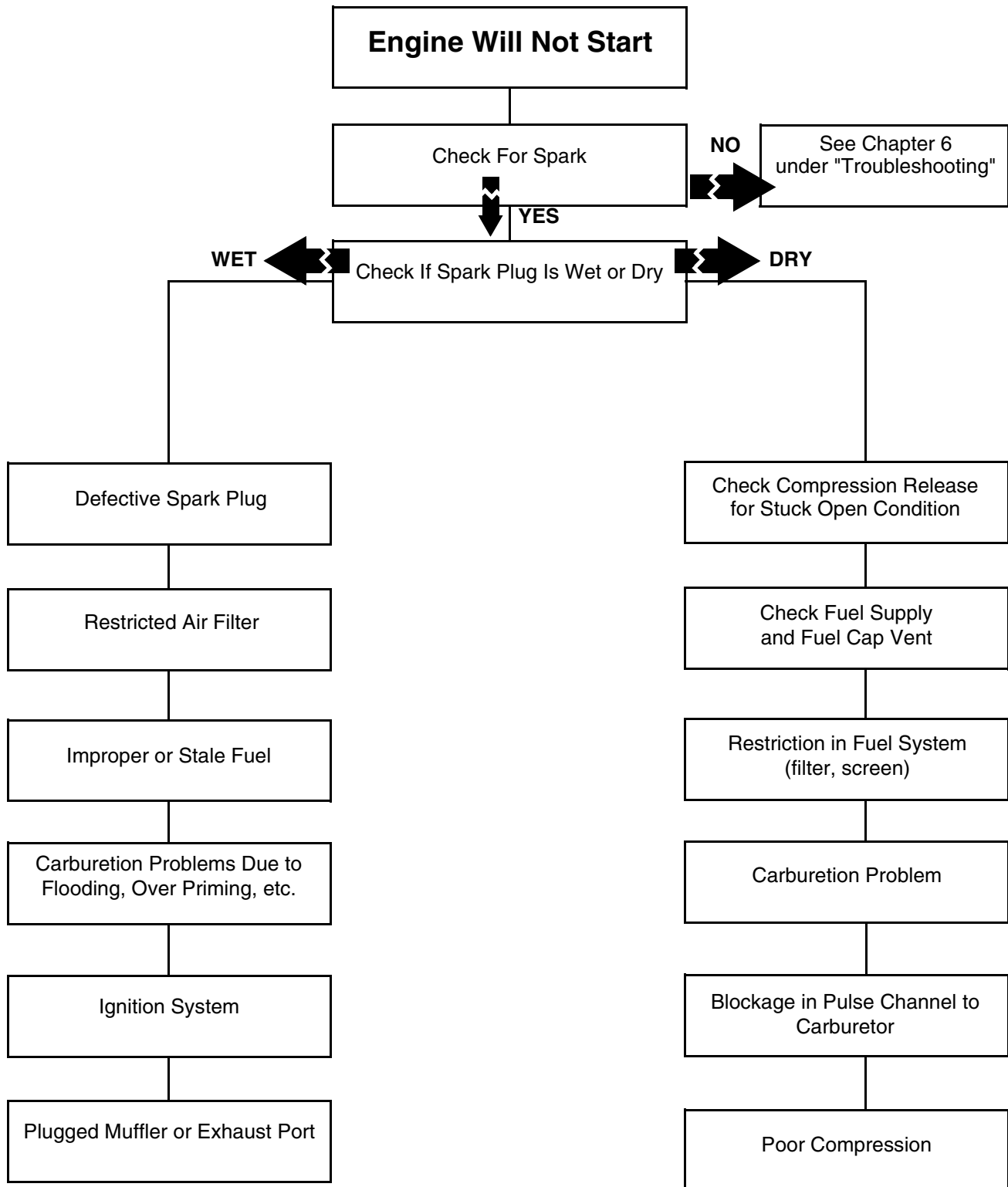

# TROUBLESHOOTING CARBURETION—TC/TM SERIES

ADJUSTMENTS	START				ACCELERATION & DECELERATION			
	Hard Starting	Fuel Dripping From Carburetor	Floods Engine When Not Running	Will Not Idle	Will Not Accelerate	Engine Stops When Closing Throttle	Low Power	No Rich Drop Off (Does Not Apply to Fixed Jets)
Low	●			●	●	●		
High					●	●	●	●
<b>FUEL SYSTEM</b>								
Plugged Tank Filter or Vent	●			●	●			●
Restricted Fuel Line	●			●	●			●
Dirt in Fuel Passage				●		●	●	●
Loose, Damaged Fuel Line		●		●		●		●
Leak in Pulse System	●			●	●			●
Restricted Pulse Channel	●			●	●			●
Loose Pump Cover Screws		●			●			●
Defective Pump Diaphragm					●	●	●	●
<b>AIR SYSTEM</b>								
Plugged Air Filter	●				●		●	●
Defective Manifold Gasket				●	●			●
Loose Carburetor Mounting Bolts				●	●			●
Worn Throttle Shaft or Valve								
Incorrect Throttle Assembly								
Loose Throttle Valve Screw								
Throttle Shaft Too Tight				●				
Bent Throttle Linkage				●				
Defective Throttle Spring				●				
Bent Throttle Stop Lever				●				
Choke Not Functioning Properly	●							
Worn Choke Shaft or Valve	●							

# TROUBLESHOOTING CARBURETION—TC/TM SERIES (CONTINUED)

METERING SYSTEM	START Hard Starting Fuel Dripping From Carburetor Floods Engine When Not Running IDLE (Low Speed) Will Not Idle Rich Idle Idles With Needle Closed or Jet Restricted (Does Not Apply to Fixed Jets) Erratic Idle 1" Needle Needs Frequent Adjustment Loads Up While Idling	ACCELERATION & DECELERATION Will Not Accelerate Engine Stops When Closing Throttle Over-rich Acceleration HIGH SPEED Will Not Run at W.O.T. Low Power No Rich Drop Off (Does Not Apply to Fixed Jets)																	
<b>LEVER</b>																			
Worn Lever	<input type="checkbox"/>	<input type="checkbox"/>	<input type="checkbox"/>	<input type="checkbox"/>	<input type="checkbox"/>	<input type="checkbox"/>	<input type="checkbox"/>	<input type="checkbox"/>	<input type="checkbox"/>	<input type="checkbox"/>	<input type="checkbox"/>	<input type="checkbox"/>	<input type="checkbox"/>	<input type="checkbox"/>	<input type="checkbox"/>	<input type="checkbox"/>	<input type="checkbox"/>	<input type="checkbox"/>	<input type="checkbox"/>
Set Too High	<input type="checkbox"/>	<input checked="" type="checkbox"/>	<input checked="" type="checkbox"/>	<input type="checkbox"/>	<input type="checkbox"/>	<input type="checkbox"/>	<input type="checkbox"/>	<input type="checkbox"/>	<input type="checkbox"/>	<input type="checkbox"/>	<input checked="" type="checkbox"/>	<input type="checkbox"/>	<input type="checkbox"/>	<input type="checkbox"/>	<input type="checkbox"/>	<input type="checkbox"/>	<input type="checkbox"/>	<input type="checkbox"/>	<input type="checkbox"/>
Set Too Low	<input type="checkbox"/>	<input type="checkbox"/>	<input type="checkbox"/>	<input type="checkbox"/>	<input type="checkbox"/>	<input type="checkbox"/>	<input type="checkbox"/>	<input type="checkbox"/>	<input type="checkbox"/>	<input checked="" type="checkbox"/>	<input type="checkbox"/>	<input type="checkbox"/>	<input type="checkbox"/>	<input type="checkbox"/>	<input type="checkbox"/>	<input checked="" type="checkbox"/>	<input type="checkbox"/>	<input type="checkbox"/>	<input type="checkbox"/>
Not Free	<input type="checkbox"/>	<input type="checkbox"/>	<input type="checkbox"/>	<input type="checkbox"/>	<input checked="" type="checkbox"/>	<input checked="" type="checkbox"/>	<input checked="" type="checkbox"/>	<input checked="" type="checkbox"/>	<input checked="" type="checkbox"/>	<input type="checkbox"/>	<input type="checkbox"/>	<input type="checkbox"/>	<input type="checkbox"/>	<input type="checkbox"/>	<input checked="" type="checkbox"/>	<input checked="" type="checkbox"/>	<input type="checkbox"/>	<input type="checkbox"/>	<input type="checkbox"/>
<b>SPRING</b>																			
Distorted	<input type="checkbox"/>	<input type="checkbox"/>	<input type="checkbox"/>	<input type="checkbox"/>	<input type="checkbox"/>	<input type="checkbox"/>	<input type="checkbox"/>	<input type="checkbox"/>	<input checked="" type="checkbox"/>	<input type="checkbox"/>	<input type="checkbox"/>	<input type="checkbox"/>	<input type="checkbox"/>	<input type="checkbox"/>	<input checked="" type="checkbox"/>	<input type="checkbox"/>	<input type="checkbox"/>	<input type="checkbox"/>	<input type="checkbox"/>
Improperly Installed	<input type="checkbox"/>	<input type="checkbox"/>	<input type="checkbox"/>	<input type="checkbox"/>	<input type="checkbox"/>	<input type="checkbox"/>	<input type="checkbox"/>	<input type="checkbox"/>	<input checked="" type="checkbox"/>	<input type="checkbox"/>	<input type="checkbox"/>	<input type="checkbox"/>	<input type="checkbox"/>	<input type="checkbox"/>	<input checked="" type="checkbox"/>	<input type="checkbox"/>	<input type="checkbox"/>	<input type="checkbox"/>	<input type="checkbox"/>
<b>DIAPHRAGM</b>																			
Leaking (Air/Fuel)	<input type="checkbox"/>	<input checked="" type="checkbox"/>	<input type="checkbox"/>	<input type="checkbox"/>	<input type="checkbox"/>	<input type="checkbox"/>	<input type="checkbox"/>	<input checked="" type="checkbox"/>	<input checked="" type="checkbox"/>	<input type="checkbox"/>	<input type="checkbox"/>	<input type="checkbox"/>	<input type="checkbox"/>	<input type="checkbox"/>	<input type="checkbox"/>	<input checked="" type="checkbox"/>	<input type="checkbox"/>	<input checked="" type="checkbox"/>	<input type="checkbox"/>
Worn Button	<input type="checkbox"/>	<input type="checkbox"/>	<input type="checkbox"/>	<input type="checkbox"/>	<input type="checkbox"/>	<input type="checkbox"/>	<input type="checkbox"/>	<input checked="" type="checkbox"/>	<input type="checkbox"/>	<input type="checkbox"/>	<input type="checkbox"/>	<input type="checkbox"/>	<input type="checkbox"/>	<input type="checkbox"/>	<input type="checkbox"/>	<input type="checkbox"/>	<input type="checkbox"/>	<input type="checkbox"/>	<input type="checkbox"/>
Improper Assembly	<input type="checkbox"/>	<input type="checkbox"/>	<input type="checkbox"/>	<input type="checkbox"/>	<input type="checkbox"/>	<input type="checkbox"/>	<input type="checkbox"/>	<input type="checkbox"/>	<input type="checkbox"/>	<input checked="" type="checkbox"/>	<input type="checkbox"/>	<input type="checkbox"/>	<input type="checkbox"/>	<input type="checkbox"/>	<input type="checkbox"/>	<input checked="" type="checkbox"/>	<input type="checkbox"/>	<input checked="" type="checkbox"/>	<input type="checkbox"/>
Defective Gasket	<input type="checkbox"/>	<input checked="" type="checkbox"/>	<input type="checkbox"/>	<input type="checkbox"/>	<input type="checkbox"/>	<input type="checkbox"/>	<input type="checkbox"/>	<input type="checkbox"/>	<input checked="" type="checkbox"/>	<input type="checkbox"/>	<input type="checkbox"/>	<input type="checkbox"/>	<input type="checkbox"/>	<input type="checkbox"/>	<input type="checkbox"/>	<input checked="" type="checkbox"/>	<input type="checkbox"/>	<input checked="" type="checkbox"/>	<input type="checkbox"/>
Loose Diaphragm Rivet	<input type="checkbox"/>	<input type="checkbox"/>	<input type="checkbox"/>	<input type="checkbox"/>	<input type="checkbox"/>	<input type="checkbox"/>	<input type="checkbox"/>	<input type="checkbox"/>	<input type="checkbox"/>	<input type="checkbox"/>	<input type="checkbox"/>	<input type="checkbox"/>	<input type="checkbox"/>	<input type="checkbox"/>	<input type="checkbox"/>	<input checked="" type="checkbox"/>	<input type="checkbox"/>	<input checked="" type="checkbox"/>	<input type="checkbox"/>
Hole in Diaphragm	<input type="checkbox"/>	<input checked="" type="checkbox"/>	<input type="checkbox"/>	<input type="checkbox"/>	<input type="checkbox"/>	<input type="checkbox"/>	<input type="checkbox"/>	<input checked="" type="checkbox"/>	<input type="checkbox"/>	<input type="checkbox"/>	<input type="checkbox"/>	<input type="checkbox"/>	<input type="checkbox"/>	<input type="checkbox"/>	<input type="checkbox"/>	<input checked="" type="checkbox"/>	<input type="checkbox"/>	<input checked="" type="checkbox"/>	<input type="checkbox"/>
Loose Cover Screws	<input type="checkbox"/>	<input checked="" type="checkbox"/>	<input type="checkbox"/>	<input type="checkbox"/>	<input type="checkbox"/>	<input type="checkbox"/>	<input type="checkbox"/>	<input checked="" type="checkbox"/>	<input type="checkbox"/>	<input type="checkbox"/>	<input type="checkbox"/>	<input type="checkbox"/>	<input type="checkbox"/>	<input type="checkbox"/>	<input checked="" type="checkbox"/>	<input checked="" type="checkbox"/>	<input type="checkbox"/>	<input checked="" type="checkbox"/>	<input type="checkbox"/>
<b>INLET NEEDLE &amp; SEAT</b>																			
Foreign Matter	<input type="checkbox"/>	<input checked="" type="checkbox"/>	<input checked="" type="checkbox"/>	<input type="checkbox"/>	<input type="checkbox"/>	<input checked="" type="checkbox"/>	<input checked="" type="checkbox"/>	<input checked="" type="checkbox"/>	<input checked="" type="checkbox"/>	<input type="checkbox"/>	<input type="checkbox"/>	<input type="checkbox"/>	<input type="checkbox"/>	<input type="checkbox"/>	<input checked="" type="checkbox"/>	<input type="checkbox"/>	<input type="checkbox"/>	<input type="checkbox"/>	<input type="checkbox"/>
Binding	<input type="checkbox"/>	<input checked="" type="checkbox"/>	<input checked="" type="checkbox"/>	<input type="checkbox"/>	<input type="checkbox"/>	<input checked="" type="checkbox"/>	<input checked="" type="checkbox"/>	<input checked="" type="checkbox"/>	<input checked="" type="checkbox"/>	<input checked="" type="checkbox"/>	<input checked="" type="checkbox"/>	<input type="checkbox"/>	<input type="checkbox"/>	<input type="checkbox"/>	<input checked="" type="checkbox"/>	<input type="checkbox"/>	<input type="checkbox"/>	<input type="checkbox"/>	<input type="checkbox"/>
Worn Needle Body or Tip	<input type="checkbox"/>	<input checked="" type="checkbox"/>	<input checked="" type="checkbox"/>	<input type="checkbox"/>	<input type="checkbox"/>	<input checked="" type="checkbox"/>	<input checked="" type="checkbox"/>	<input type="checkbox"/>	<input checked="" type="checkbox"/>	<input type="checkbox"/>	<input type="checkbox"/>	<input type="checkbox"/>	<input type="checkbox"/>	<input type="checkbox"/>	<input type="checkbox"/>	<input type="checkbox"/>	<input type="checkbox"/>	<input type="checkbox"/>	<input type="checkbox"/>
<b>NOZZLE CHECK VALVE</b>																			
	<input checked="" type="checkbox"/>	<input type="checkbox"/>	<input type="checkbox"/>	<input type="checkbox"/>	<input checked="" type="checkbox"/>	<input type="checkbox"/>	<input type="checkbox"/>	<input checked="" type="checkbox"/>	<input type="checkbox"/>	<input checked="" type="checkbox"/>	<input checked="" type="checkbox"/>	<input checked="" type="checkbox"/>	<input type="checkbox"/>	<input type="checkbox"/>	<input type="checkbox"/>	<input type="checkbox"/>	<input type="checkbox"/>	<input type="checkbox"/>	<input type="checkbox"/>

## TESTING

1. After repeated efforts to start the engine using the procedure listed in the operator's manual fail, check for spark by removing the high tension lead and removing the spark plug. Install a Tecumseh Spark Plug Tester (part # 670366) and check for spark. If the spark is bright blue and fires every revolution, proceed to step # 2. If no spark, weak spark, or intermittent spark, see Chapter 6 "Ignition" under "Troubleshooting".
2. Remove the spark plug and visually check the removed spark plug for a wet condition indicating the presence of fuel mixture in the cylinder.
3. If the spark plug is dry, check for restrictions in the fuel system before the carburetor. If the spark plug is wet, continue with step #7. Check the fuel cap vent, the cap must allow air to be blown through it when testing. Using a proper draining receptacle, remove the fuel line from the carburetor inlet fitting (TC Type I) or fuel tank (TC Type II/TM) and pull off the fuel line. Examine the fuel flow and fuel condition. Improper fuel flow indicates the fuel, fuel line, filter, or tank require cleaning or replacement.
4. Visually inspect the choke shutter for complete closing or check to see fuel flowing from the main nozzle during priming. Remove the air cleaner element or air cleaner assembly to provide access for visual inspection.
5. If the fuel flow to the carburetor is adequate and no fuel flows out the main nozzle during priming or choking, the carburetor will require service. Consult the Troubleshooting Carburetion Chart for possible causes for the lack of fuel.
6. Check the compression release on TM engines. Low compression, no fuel present on the spark plug, adequate fuel flow and a known good functional carburetor indicates an internal engine problem exists. See Chapter 7 under "Troubleshooting".
7. Check the engine compression using compression tester (part # 670358) and follow the tester's recommended procedure. Low compression, no fuel present on the spark plug, adequate fuel flow and a known good functional carburetor indicates an internal engine problem exists. See Chapter 7 under "Troubleshooting".

## SERVICE

### CARBURETOR PRE-SET AND ADJUSTMENT

The Walbro, Tillotson and Tecumseh carburetors used on TC engines have non-adjustable main mixture jets. Only the idle mixture may be adjustable by turning the idle mixture screw. Use the following procedure to pre-set the idle mixture screw. Turn the idle mixture screw (clockwise) finger tight to the closed position, then turn the screw counterclockwise to obtain the proper preset (diag. 3-10).

Walbro model WTA, WT	1 - 1 1/8 turns
Tillotson model HU	1 1/4 - 1 3/8 turns
Tecumseh model	Fixed

### Final Idle Mixture Adjustment

Start the engine and allow it to reach normal operating temperature (after 3-5 minutes). As the speed control is set at the idle position, turn the idle mixture screw slowly clockwise until the engine R.P.M. just starts to decrease. Stop and note this screw position. Turn the idle mixture screw slowly counterclockwise. The engine will increase R.P.M. Continue to slowly turn the screw until the engine R.P.M. starts to decrease. Note this position and turn the mixture screw back clockwise halfway between the two engine R.P.M. drop off positions. The idle mixture adjustment is complete.

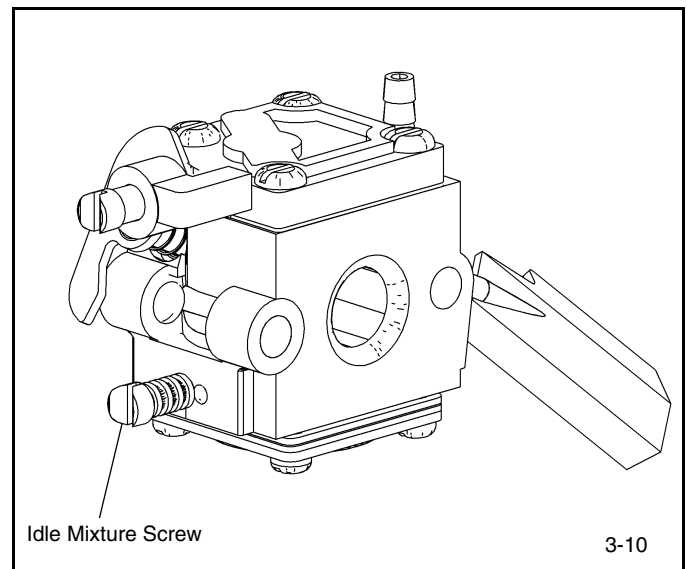

## CARBURETOR DISASSEMBLY

1. Note or mark the location and sequence of the diaphragm(s), gasket(s), and the metering or pump cover. Remove the screw(s), gaskets, and diaphragms.
2. Remove the idle mixture screw. On Tillotson model HU carburetors, remove the plastic screw or brass plug over the main mixture jet and remove the main mixture jet if necessary for cleaning (diag. 3-11).
3. Use a 8-32 tap with the tapered flutes removed to turn into the brass welch plug until it bottoms and begins to turn the welch plug. Carefully pull the welch plug from the carburetor body.
4. Note or mark the location and action of the throttle and air vane, and choke shaft (if applicable). Remove the screw holding the throttle or choke shutter to the shaft. Remove the Torx T8 screw (use part # 670334) holding the air vane to the throttle shaft if applicable. Remove the clip screw, dust seal retaining clip, and throttle shaft. On some older Walbro carburetors it is necessary to remove the circlip on the end of the throttle shaft to remove the shaft (diag. 3-11).
5. Remove the inlet needle valve, metering lever, and metering lever spring by removing the retainer screw on the pivot pin (diag. 3-11).
6. Remove the fuel inlet screen and check valve screen using an "O" ring pick. Remove all welch plugs using a sharpened small chisel. Drive the sharpened chisel into the welch plug, push down on the chisel to pry the welch plug out of position. Be careful not to damage the carburetor body (diag. 3-12).
7. On Walbro carburetors, the fuel inlet fitting can be removed with a pliers using a twisting and pulling motion. Do not re-use the old fuel fitting. The fuel fitting on Tillotson carburetors is not replaceable. Do not remove. Carburetor cleaner will not affect this fitting.
8. Clean all metallic parts in carburetor cleaner. Do not exceed 30 minutes soak time. Blow out all fuel passages with compressed air. Do not use tag wire to clean the orifice in the main mixture seat assembly. The main mixture seat assembly contains a teflon disc check valve. If the disc is damaged with tag wire, the carburetor will not function properly.

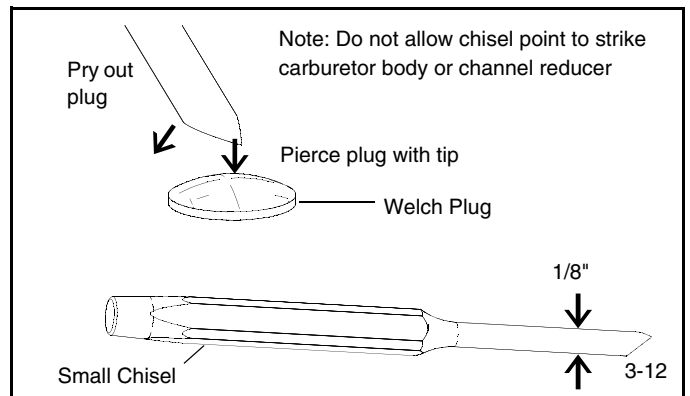
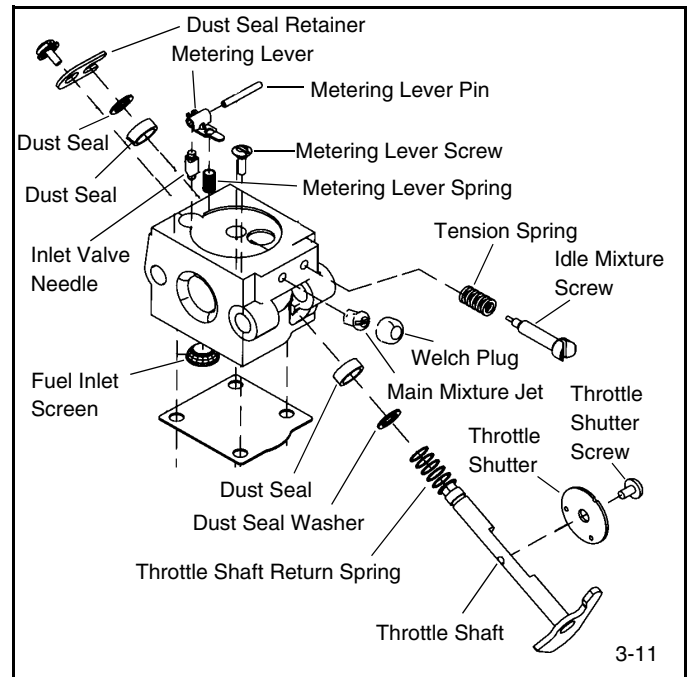

## CARBURETOR INSPECTION

Visually examine the throttle lever shaft and choke shaft for wear at the bearing points in the carburetor body. Inspect the pump and metering diaphragms for hardness, fuel contamination, holes or tearing in the diaphragm. Pump diaphragm flapper valves should appear flat with no curling. Check the inlet screen and check valve screen for contamination. Check the atmospheric vent hole in the metering cover and clean if necessary.

Check the inlet needle for wear on the taper portion of the needle. Replace as necessary.



## CARBURETOR ASSEMBLY

1. Install new inlet screen(s) using a small flat punch slightly smaller than the screen. Push in until the screen contacts the seat.
2. If removed, install the high speed jet. Use a slightly larger flat punch to install the brass welch plug over the high speed jet. The closed, tapered end of the plug goes toward the jet. Tap the brass welch plug in until it is flush with the carburetor body. Apply sealant like fingernail polish to the brass plug.
3. Install new welch plug(s) using a flat punch equal to or slightly larger than the plug. The welch plug(s) must be flattened by taps with a small hammer on the installing punch. Sealant such as fingernail polish is recommended to apply to an installed welch plug. Use sparingly and wipe off excess immediately (diag. 3-13).
4. Install the inlet needle, spring, metering lever and pin. The metering lever hooks on the inlet needle and rests on the metering spring. Install as an assembly and install the retaining screw (diag. 3-14).
5. Check the metering lever tip height using a metering lever gauge (part # 670325). The tip height should be .060" to .070" (1.52 mm to 1.77 mm) from the face of the carburetor body on Walbro carburetors. On Tecumseh and Tillotson carburetors the tip of the metering lever should be flush with surface of the carburetor body.
6. Install the idle mixture screw and spring and back the screw out from the closed position 1 - 1-1/8 turns for Walbro, 1-1/4 - 1-3/8 turns for Tillotson carburetors.
7. Install the metering diaphragm, cover gasket, and cover. Place the cover gasket (over the locator pins on Walbro only) on the carburetor body, add the metering diaphragm with the long rivet head toward the carburetor body on top of the gasket, add the cover and fasten the four screws (diag. 3-15).

### NOTE

*Do not re-use old choke or throttle plate shutter screws. New screws are treated with a dry Loctite adhesive to secure them in place.*

8. Install the pump gasket over the locator pins on the pump cover, add the pump diaphragm next, and place the assembly on the carburetor body. Check to see that the locator pins fit the corresponding holes in the carburetor body. Install the pump cover retaining screw (diag. 3-15).
9. If removed on Walbro carburetors, install a new fuel inlet fitting in the same position as the original (diag. 3-15). When installing a new fitting, insert the tip into the carburetor body, then coat the exposed portion of the shank with Loctite grade A (red), then press it in squarely using support on the opposite side to prevent damage to the carburetor body or fitting. Press it in until the fitting bottoms out in the carburetor body.

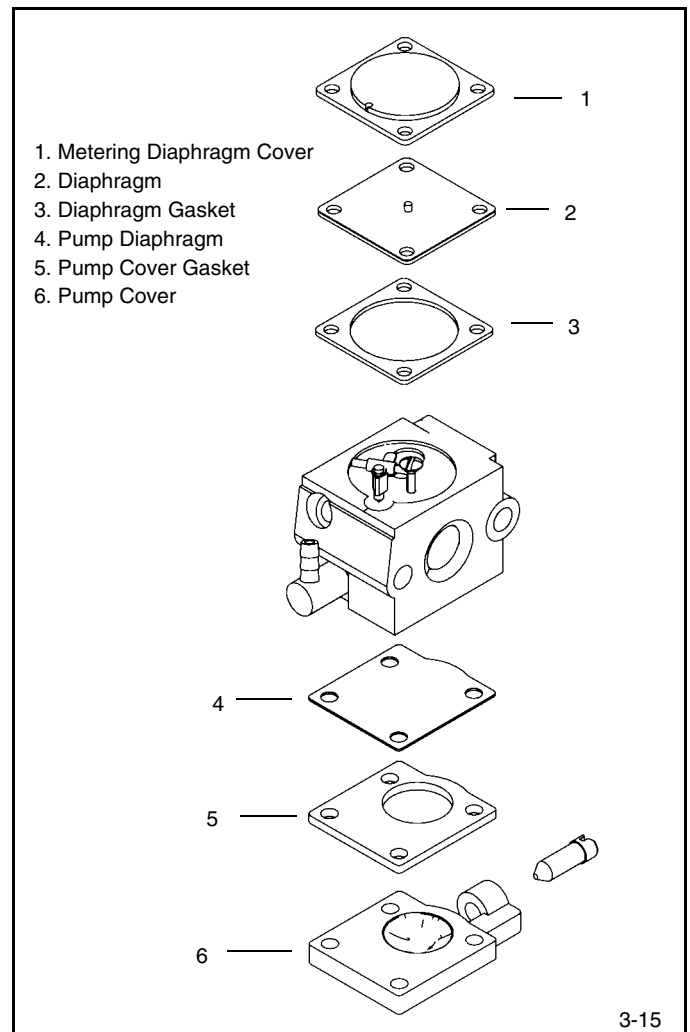
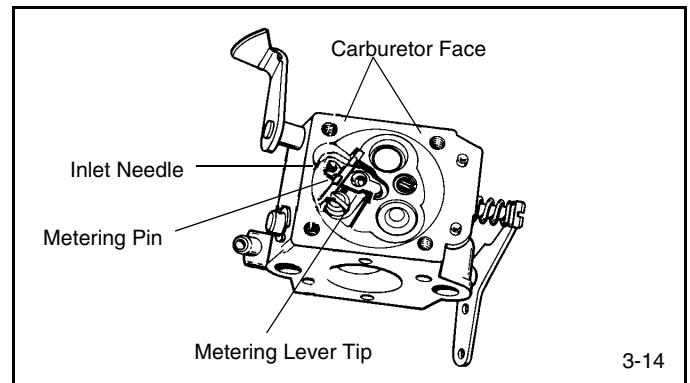
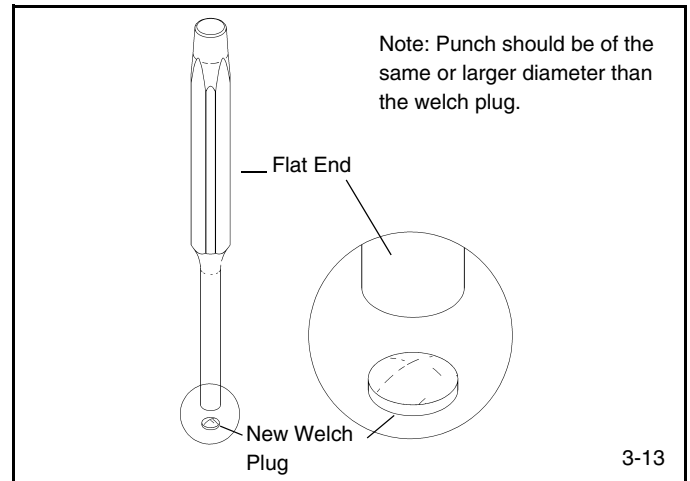

10. Install the choke and throttle shaft assemblies in the reverse order of removal. Visually check for proper operation of the choke and throttle.
11. If applicable, attach the air vane and torque the mounting screw to 3-5 inch pounds (.34 Nm - .57 Nm).
12. TC and TM series engines use an insulator / spacer between the carburetor and cylinder. That spacer **MUST** be installed correctly for the fuel pump to operate (diag. 3-16). Use the appropriate style to determine the correct position of the spacer block.

**NOTE**

*The sleeve spacers must be installed before installing the fuel tank on later TM engines.*

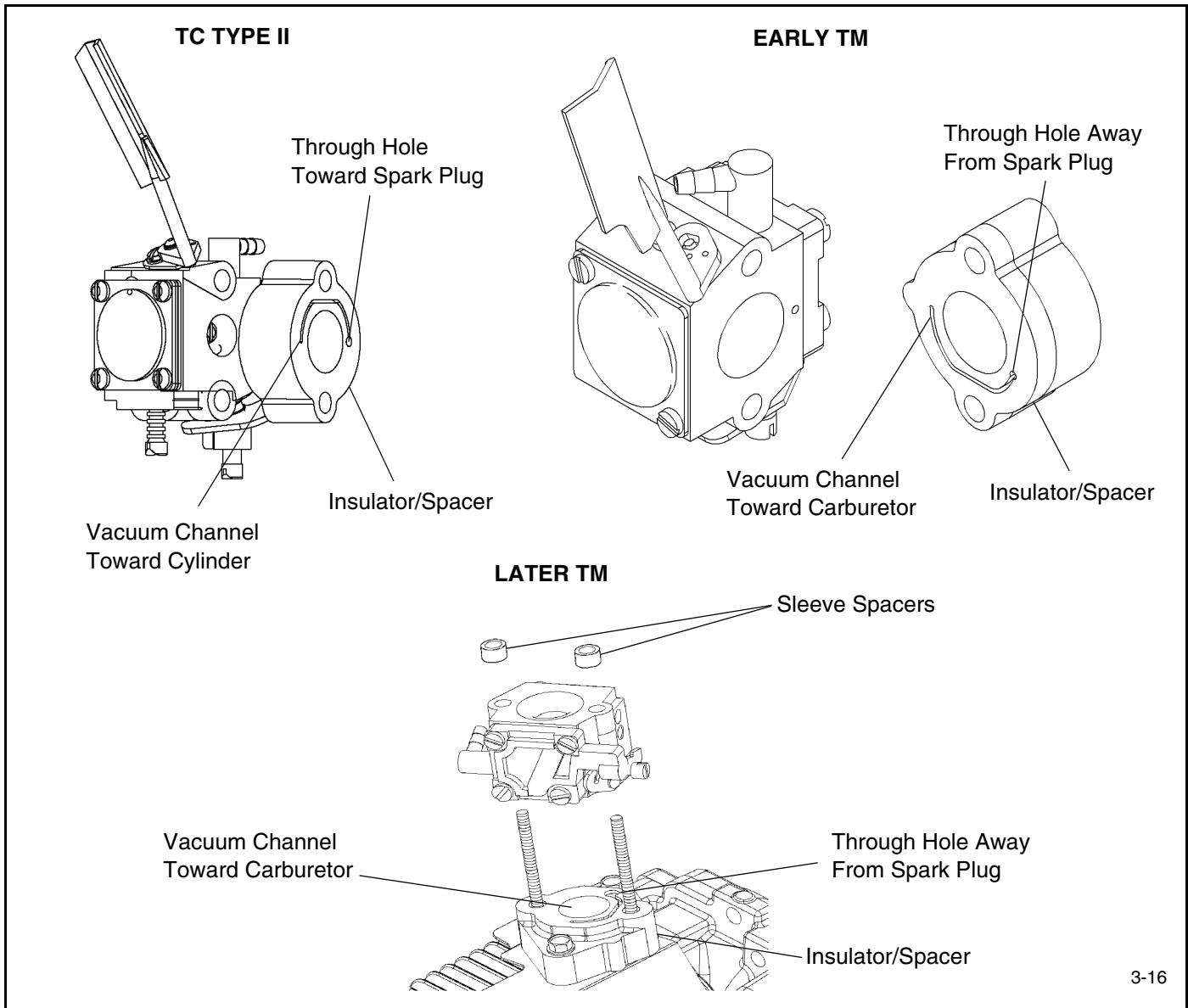

3-16

## EMISSIONIZED TC/TILLOTSON CARBURETOR

The Tillotson carburetor is an emissions grade carb. It has a married idle and high speed circuitry with limited jet adjustments on the idle (diag. 3-17).

### EMISSIONS CARBURETOR IDLE MIXTURE ADJUSTMENT PROCEDURES

The carburetor is preset at the factory at a normal setting required for initial engine operation.

Allow the engine to reach normal operating temperature (after 3-5 minutes).

Set the engine speed control in the idle position. With the engine at idle speed (Note: must be less than 2400 R.P.M. for accurate adjustment). Using a small tip screw driver that fits through the access hole in the limiter cap, adjust the mixture screw slowly clockwise until the engine R.P.M. just starts to decrease. Stop and note this screw position. Turn the idle mixture screw slowly counterclockwise. As the engine increases R.P.M. continue to slowly turn the screw counterclockwise until the engine R.P.M. starts to decrease. Note this position and turn the mixture screw back clockwise halfway between the two engine R.P.M. drop off positions.

Verify the engine will accelerate from low speed to high speed and that the idle speed remains at the desired setting.

Once adjustments are complete, center the adjustment limiter cap between the two stops and press inward to engage the limiter. The limiter will snap into position and engage the adjusting screw. All future adjustments should now be made using the adjusting slot in the limiter cap.

#### CAUTION

Once the limiter cap is snapped into place it is not possible to remove the limiter or to adjust the mixture screw beyond the limits of the limiter assembly. Make sure that initial adjustments are made per the above procedure prior to engaging the limiter cap.

## TC/TM, EMISSIONIZED TECUMSEH CARBURETOR

The Tecumseh emissions diaphragm carburetor has fixed main and idle jets (diag. 3-18). It uses a married idle and high speed circuitry. The idle has a metering jet that can be removed for cleaning. It is covered by a small cap that must be removed to expose the jet for servicing. No adjustments or presets are required. The idle jet should be turned until tight 5-8 inch pounds (0.5 Nm), and the cap should then be installed to cover the jet.

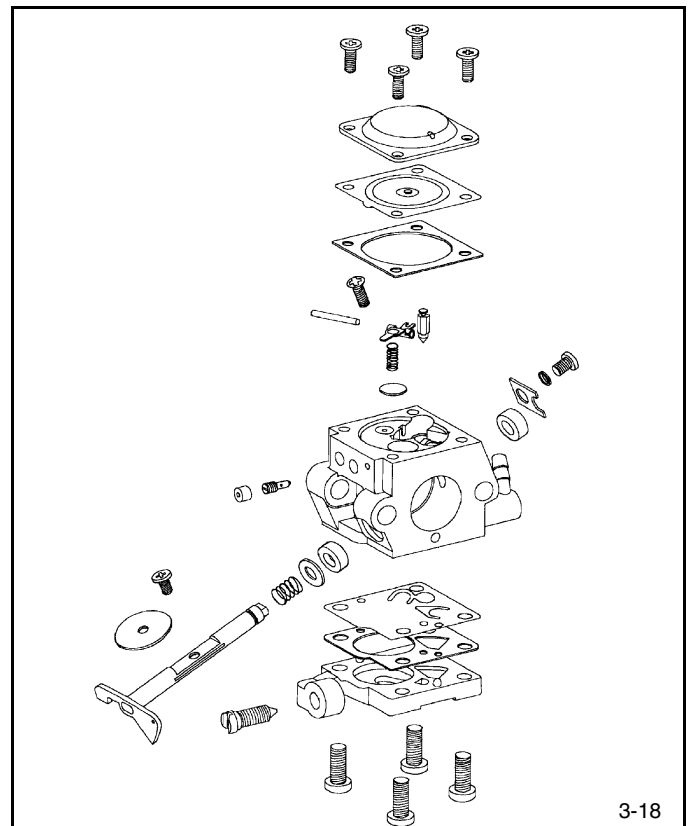
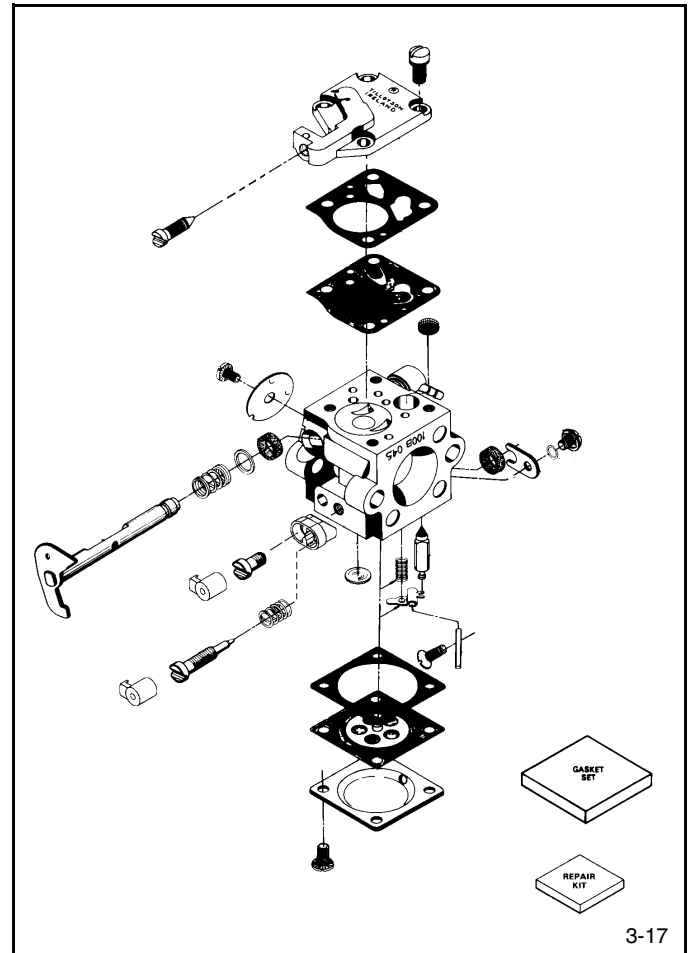

## FUEL TANK SERVICE

TC Type II/TM engines have fuel tanks with an integral fuel screen and integral outlet fuel fitting. Integral screens or fittings are not serviceable (diag. 3-19). Some TC Type I engine models use a pressed in fuel filter or a weighted filter and a flexible fuel line in the tank. Pressed in fuel filters and fittings can be serviced using the following procedure (diag. 3-20).

1. Press the fuel fitting into the tank and feed the fuel line in until the filter can be removed through the filler neck. Remove the filter and fuel line if necessary.
2. To install a new filter and fuel line: Cut the end of the fuel line at approximately a 20° angle to make installation of the fuel line through the hole in the fuel tank easier. Push the new fuel line through the tank outlet until the fuel line protrudes through the filler neck. Cut the angled portion from the fuel line.
3. On tanks without weighted filters, push a new filter on the fuel line. For weighted filters, slide the new retaining ring on the fuel line protruding from the filler neck. Push the fitting into the line to the fitting shoulder. Slide the retaining ring over the groove in the fitting and crimp the retaining ring using a pliers.
4. Attach the fuel line and weighted fuel filter if applicable. Pull the fuel line through the tank outlet. The filter barb or the fuel fitting barb must protrude from the tank.

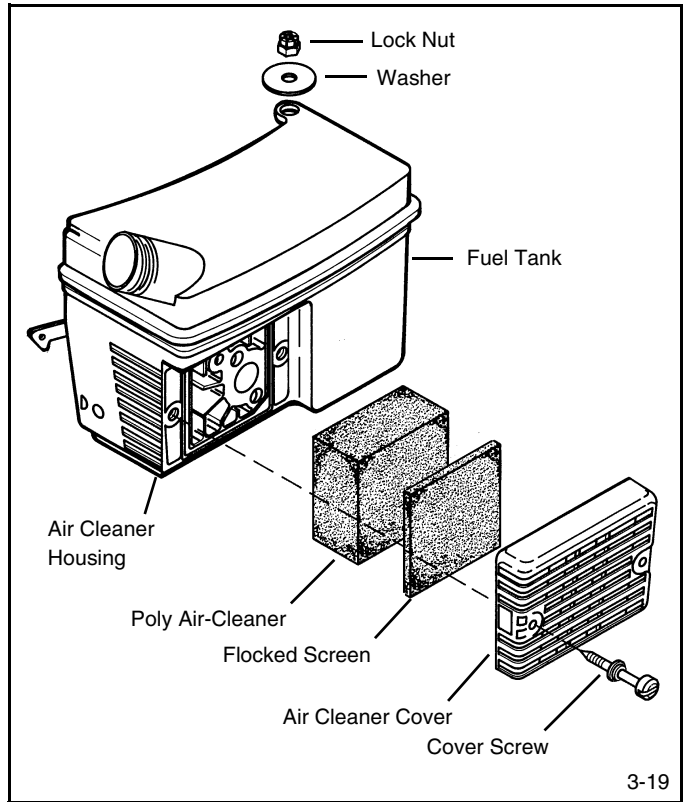

3-19

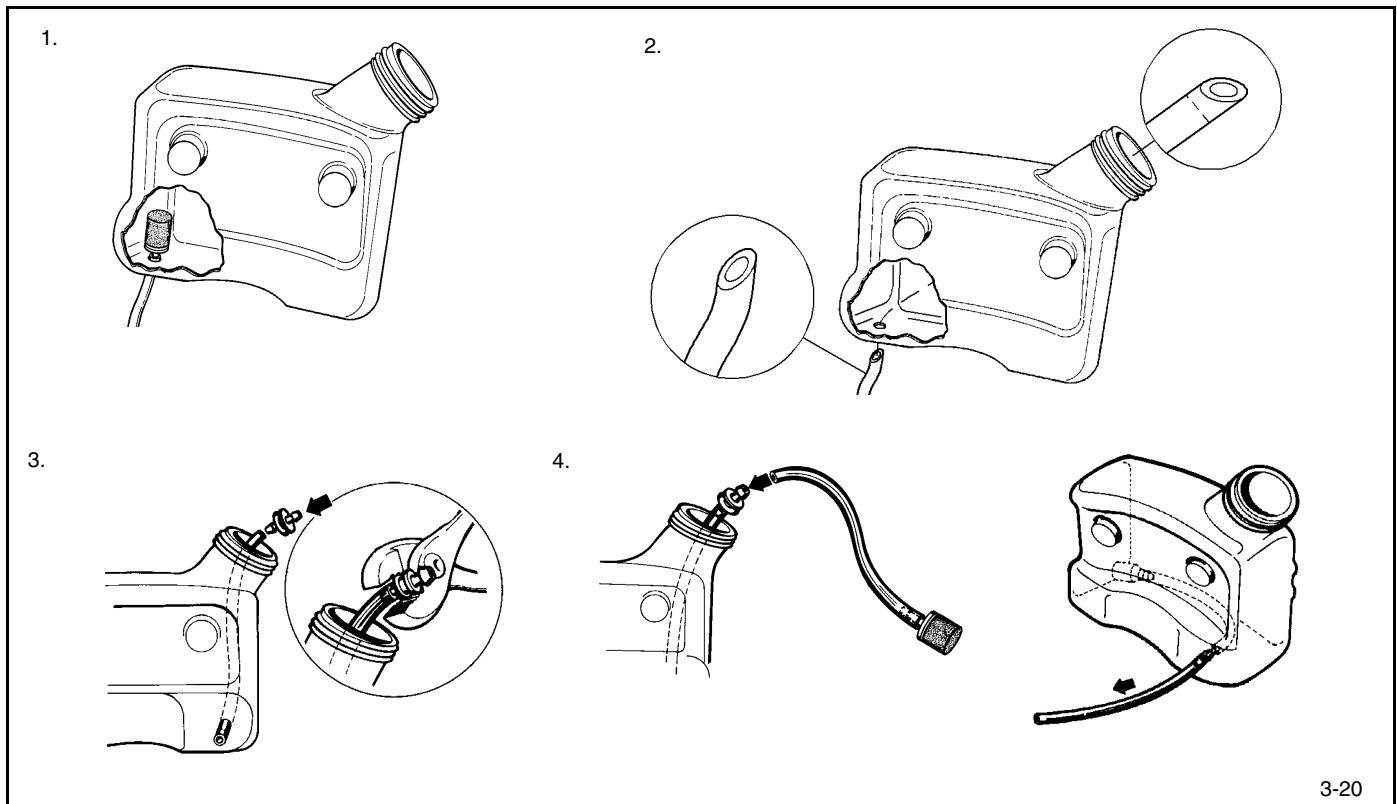

3-20

# CHAPTER 4 GOVERNORS AND LINKAGE

## GENERAL INFORMATION

TC/TM series engines are equipped with pneumatic (air vane) governors. The governor's function is to maintain a R.P.M. setting when engine loads are added or taken away. Air vane governors are controlled by the air velocity created by fins on the flywheel. Changes in the engine R.P.M. cause the air vane to move. This movement opens the throttle shaft either by a link between the air vane and the throttle plate, or the air vane is mounted directly onto the throttle shaft. The throttle is opened as the engine R.P.M. drops and is closed as the engine load is removed.

This chapter includes governor assembly linkage and speed control illustrations to aid in assembly.

## OPERATION

Engine R.P.M. changes cause an increase or decrease in the air velocity created by the fins on the flywheel. The air velocity exerts pressure on the air vane while a governor spring exerts pressure against the air velocity force. The air vane pivots on the engine blower housing base or is attached to the throttle shaft of the carburetor. As an engine load is applied and the engine's R.P.M. drop, the air velocity also drops, allowing the governor spring to pull open the throttle shaft and increase engine speed (diag. 4-1).

If the engine uses a remote speed control, the bowden wire will move the speed control plunger or the throttle shaft. Moving the speed control plunger results in changing the governor spring tension which increases or decreases the engine's governed speed.

## COMPONENTS

1. AIR VANE
2. BACKLASH SPRING
3. GOVERNOR LINK
4. GOVERNOR SPRING
5. MOUNTING SCREW
6. SPEED ADJUSTMENT SCREW
7. SPEED CONTROL BODY
8. SPEED CONTROL LEVER
9. SPEED CONTROL PLUNGER

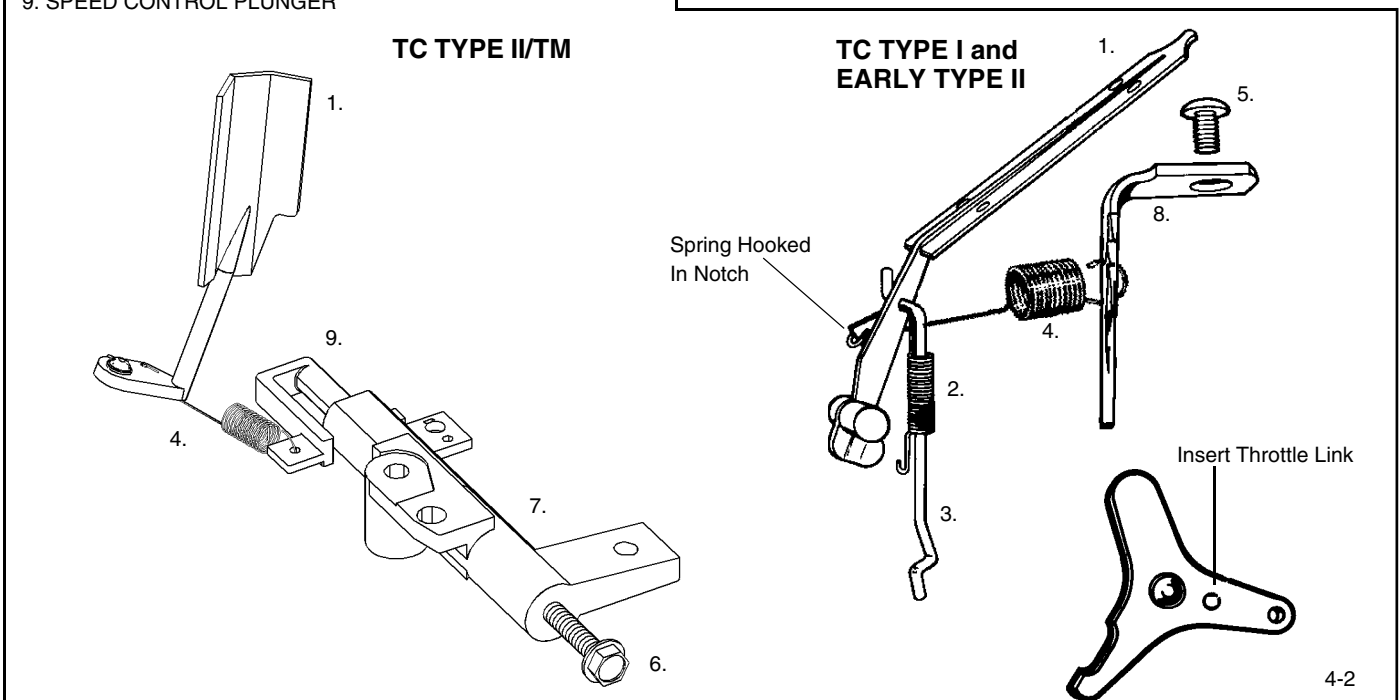
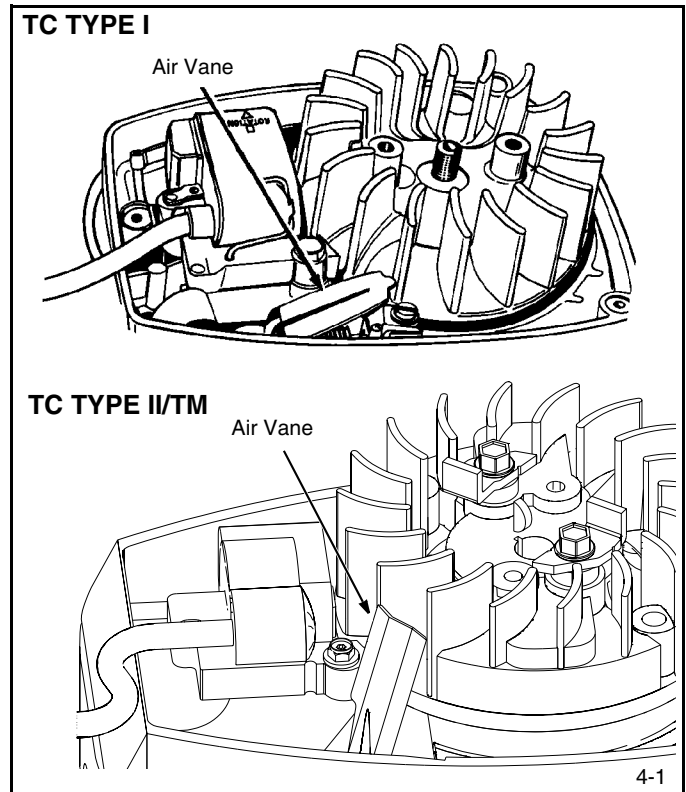

# TROUBLESHOOTING

## ENGINE OVERSPEEDING

1. If the engine runs wide open (faster than normal), shut the engine off or slow it down **immediately**.
2. Visually inspect the air vane, linkage, carburetor throttle shaft, and speed control for debris blockage, binding, breakage, or incorrect hook-up. Check the governor spring for a stretched or distorted condition. To view the components, remove the recoil assembly and/or fuel tank if necessary. For information on the proper linkage or spring connections, review the appropriate diagrams in this section.
3. Clean, correct or replace binding or damaged parts. Set the speed control to the recommended engine R.P.M.

## ENGINE SURGING

1. Try to stabilize the engine R.P.M. by holding in one position the carburetor throttle shaft on the exterior of the carburetor.
2. If the engine R.P.M. stabilizes, the governor or governor adjustment should be checked. Follow the procedure under "Governor Adjustment" in this chapter. If the engine R.P.M. does not stabilize, the engine will require additional checks. Some surging problems can be carburetor or fuel related. Additional information can be found in the troubleshooting section of Chapter 3.
3. If the problem persists after the governor adjustment, check the engine R.P.M. found on microfiche card # 30 or in the computer parts lookup. If the setting for high and low speed are within the listed specification and a slight surge is experienced, increasing the engine idle speed slightly may eliminate this condition.
4. Visually inspect the air vane, linkage, carburetor throttle shaft, and speed control for debris blockage, binding, breakage, or incorrect hook-up. Check the governor spring for a stretched or distorted condition. To view the components, remove the recoil assembly and/or fuel tank if necessary. For information on the proper linkage or spring connections, review the appropriate diagrams in this section.

## SERVICE

For governor disassembly or assembly procedures see "Service" in Chapter 7.

## GOVERNOR ADJUSTMENT

Three different styles of governor systems are used on TC/TM engines. Use the following illustrations (diags. 4-3, 4-4 and 4-5) to identify the governor system used and the following procedure to adjust the governed engine speed.

1. Allow the engine to run for at least 5 minutes to reach the operating temperature. Make sure the air filter (if equipped) is clean and the choke is in the off position.
2. Using a Vibratach (part #670156) or other tachometer, determine the engine's R.P.M. at idle and wide open throttle. Consult microfiche card # 30 or the computer parts lookup to obtain the recommended engine speeds.
3. Using the applicable illustration, either bend the speed adjusting lever toward the spark plug end of the engine to decrease high speed R.P.M., or bend the lever in opposite direction to increase R.P.M. On TC Type II/TM engines, turn the speed adjustment screw out to increase or in to decrease engine high speed R.P.M. If the speed adjustment screw is turned out to increase the engine R.P.M., the speed control lever must be moved to allow the speed control plunger to contact the speed adjustment screw.
4. The low speed is set by moving the throttle control to the lowest speed position and adjusting the low speed adjustment screw on the carburetor.

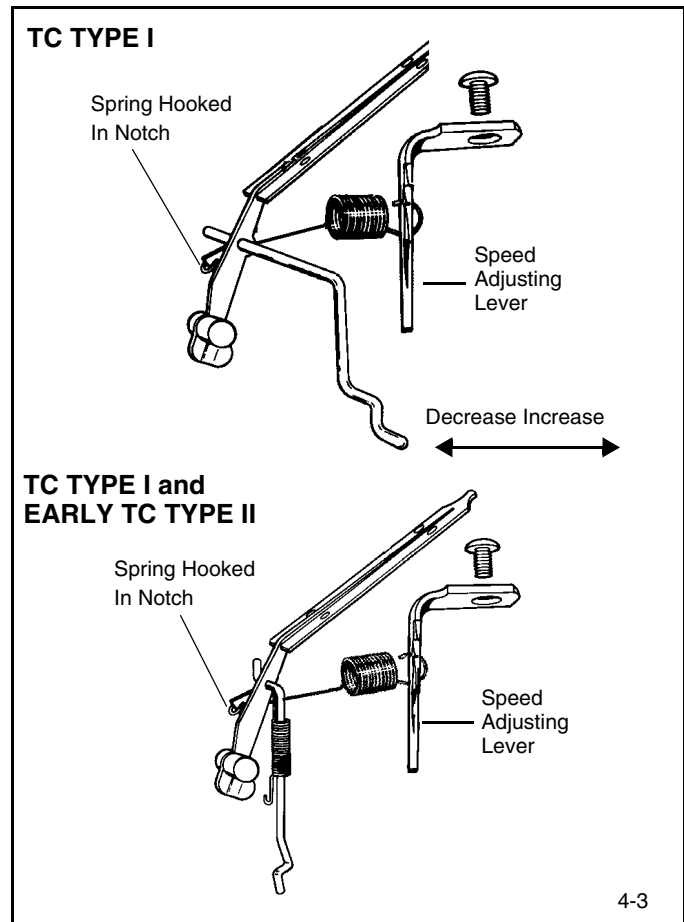

**TC TYPE I and  
some TC Type II**

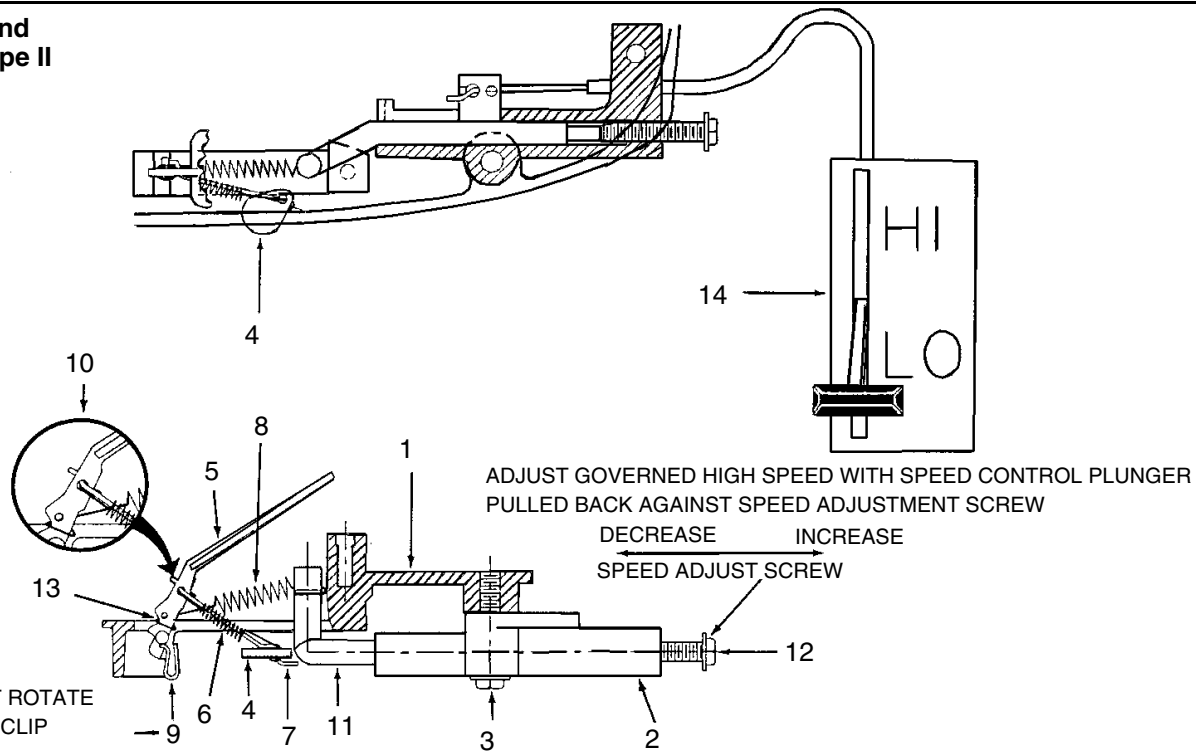

AIR VANE MUST ROTATE  
FREELY AFTER CLIP  
IS INSTALLED

ITEM	DESCRIPTION
1	Base - Housing
2	Body Assy. - Speed Control
3	Screw
4	Carburetor Throttle Plate
5	Air Vane
6	Spring - Backlash
7	Link - Governor

ITEM	DESCRIPTION
8	Spring - Governor
9	Clip - Spring
10	Spring and Link Attachment
11	Speed Control Plunger
12	Speed Adjustment Screw
13	Notch in Air Vane for Governor
14	Spring Attachment Speed Control Lever

**TC TYPE II/TM**

Decrease (IN)  
Increase (OUT)  
Speed Adjusting Screw

Spring Color	Spring Position
Orange or Green	1
Pink, Red, or Black	2

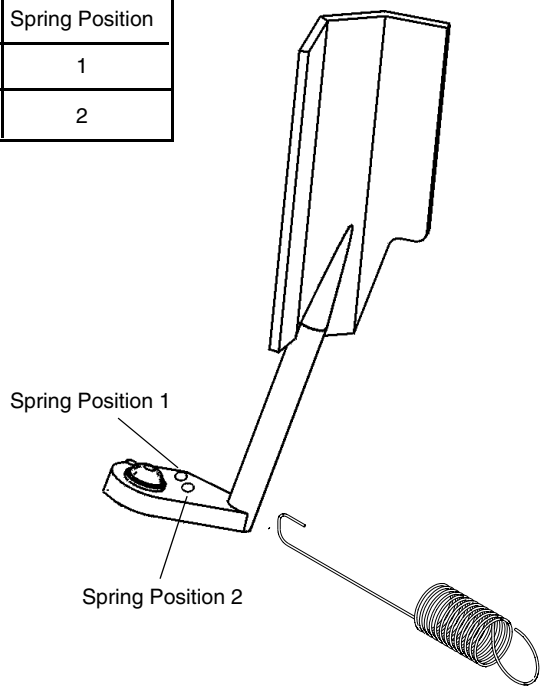
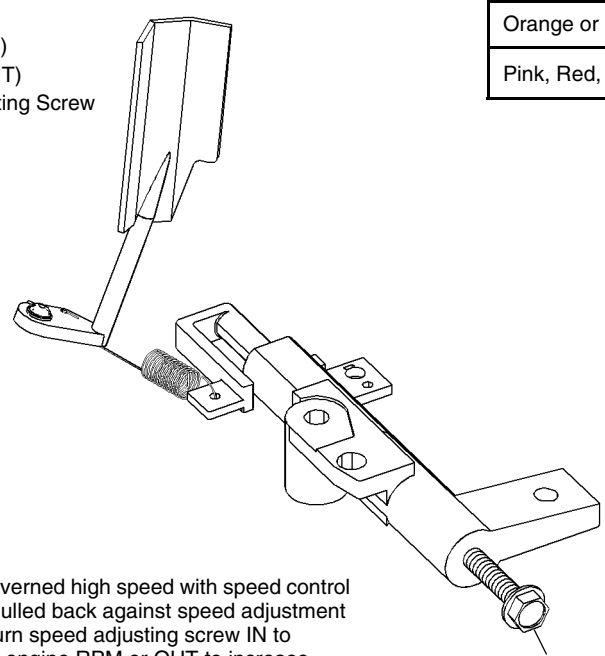

Adjust governed high speed with speed control plunger pulled back against speed adjustment screw. Turn speed adjusting screw IN to decrease engine RPM or OUT to increase RPM.

Speed Adjusting Screw

# CHAPTER 5 REWIND STARTERS

## GENERAL INFORMATION

TC/TM series engines have the recoil assembly as a part of the engine's blower housing. Two different styles of recoil starters are used along with different starter rope locations. Use the engine model and specification number to identify the recoil style and correct replacement parts.

## OPERATION

### TC TYPE I

As the starter rope is pulled, the starter pulley rotates on the center leg of the starter. The starter pawl is connected to the starter pulley by an offset hole in the pawl and a corresponding raised boss on the pulley. The pawl has an oversized inside diameter which allows the pawl to be pulled off center. The flat contact surface of the pawl engages with one of the flywheel fins. This engagement turns the flywheel until the engine fires and the flywheel speed exceeds the speed of the starter pulley. The flywheel fins push the pawl (using the ramp side) to the disengaged position. The brake spring slows the pulley and pawl from turning (diag. 5-1).

### TC TYPE II/TM

This starter uses two engagement pawls bolted to the flywheel with shoulder bolts. Each pawl uses an engagement spring to keep the pawl in contact with the pulley hub. The pawls lock into two of the four notched surfaces located on the starter pulley when the starter rope is pulled. When the engine fires and the flywheel speed exceeds the speed of the starter pulley, the pawls disengage, and centrifugal force keeps the pawls in the disengaged position (diag. 5-1).

## COMPONENTS

1. Blower Housing	4. Pulley	8. Retainer Screw
2. Recoil Spring	5. Pawl	9. Dog Screw
3. Washer	6. Brake Spring	10. Starter Dog
	7. Retainer	11. Pawl Spring

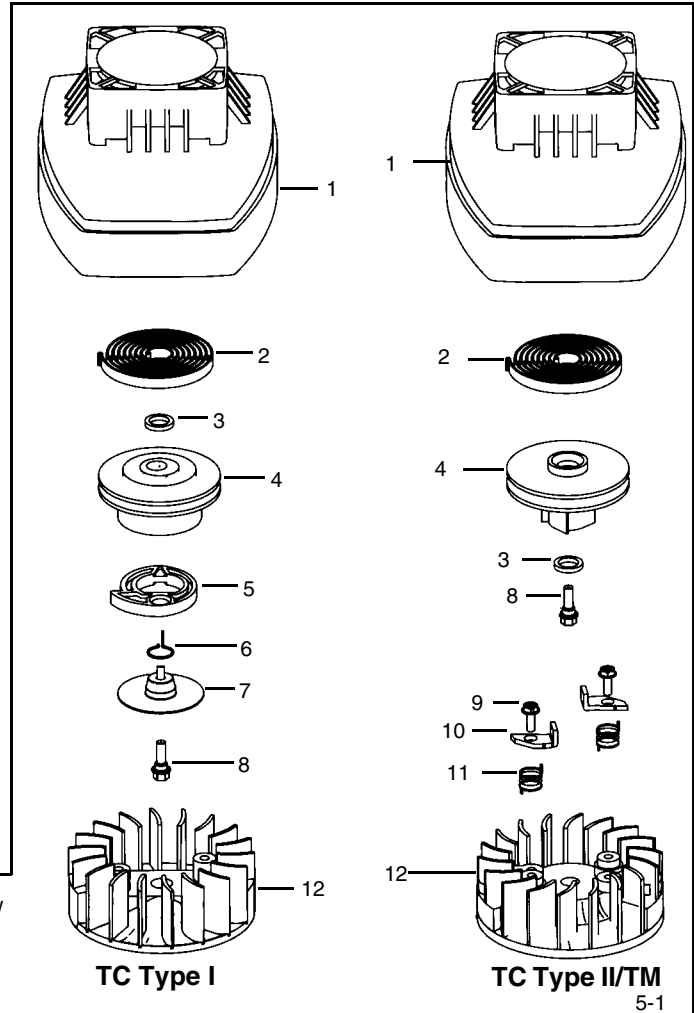

## SERVICE

Starter related problems will require the starter to be removed from the engine to diagnose the cause. On TC Type I engines, try starter operation off the engine to see pawl engagement. Visually inspect the starter pawl, brake spring, retainer, pulley, washer(s) and rope for wear or breakage. Repair or replace as necessary. On TC Type II/TM engines, recoil disassembly is necessary only if the pulley is worn, the recoil will not retract, or the rope needs replacement. Check starter pawl engagement on the flywheel for broken springs, sticking or bent condition, or loose pawl screws.

## DISASSEMBLY PROCEDURE

1. Remove the fuel tank spring and recoil assembly from the engine. On TC Type II/TM engines, the air filter and fuel tank must be removed before the recoil assembly.

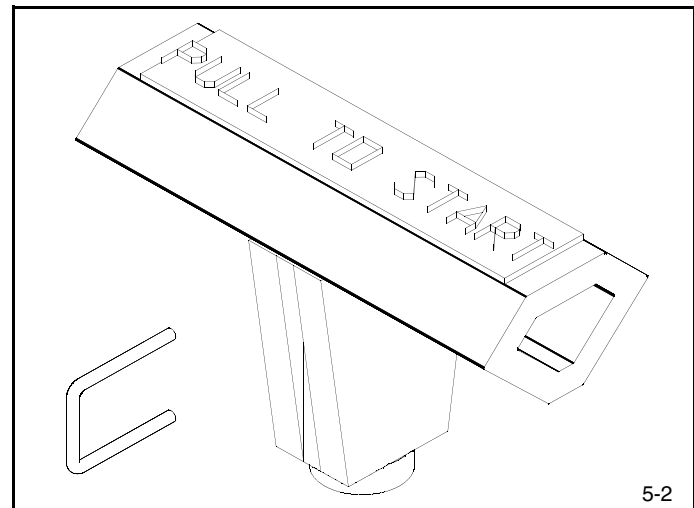



2. Release the recoil spring tension on the rope by removing the staple or knot in the starter handle and slowly release the rope into the recoil housing (diag. 5-2).
3. Remove the 5/16" retainer screw. On TC Type I starters, remove the pawl retainer, brake spring, and pawl.
4. Remove the starter pulley. CAUTION! Be careful not to pull the rewind spring out of the blower housing when removing the starter pulley. The rewind spring will uncoil and expand with force if removed from the blower housing, which can cause serious injury.

## ASSEMBLY PROCEDURE

1. Lightly grease the center leg and the area where the rewind spring will rest in the blower housing with "Chem-Lube" or "Lubriplate" (diag. 5-3).
2. Install a new starter spring if necessary. Securely grip the rewind spring a short distance away from the spring tail with a needlenose pliers. Position the rewind spring in the blower housing and hook the spring tail to the housing as shown. Make sure the spring tail is fully seated before slowly releasing the needlenose pliers from the spring. Push the coiled spring into the recessed boss area and discard the spring holder. Apply a thin coating of "Chem-Lube" to the top of the spring (diag. 5-4).
3. Insert the starter rope into the starter pulley and tie a left handed knot in the end of the rope. Wind the starter rope counterclockwise (as viewed from the pulley bottom) on the pulley and place the end of the rope in the notch in the pulley (diag. 5-5).
4. Place the pulley in the blower housing, press down and rotate the pulley until the pulley drops down and catches the end of the rewind spring. On TC Type II/TM models, continue assembly at step 7 (diag 5-6).
5. Lightly grease the pawl retainer and place the pawl (with the numbers up) on the retainer. Place the brake spring on the center of the retainer with the tab locating the pawl (diag. 5-7).
6. Install the retainer, pawl, and spring assembly on the center leg, locate the notch in the center leg and the tab of the retainer and align when installing (diag. 5-8).
7. Insert the retainer screw and torque to 30-40 inch pounds (3.4 Nm - 4.5 Nm).
8. Use the starter rope or fingers to turn the pulley and pre-wind the recoil spring a minimum of 1-3/4 and a maximum of 2-1/2 turns in a counterclockwise rotation.
9. Feed the starter rope through the starter grommet and secure the starter handle using a left hand knot.

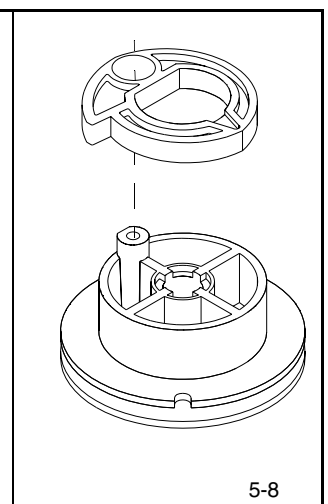
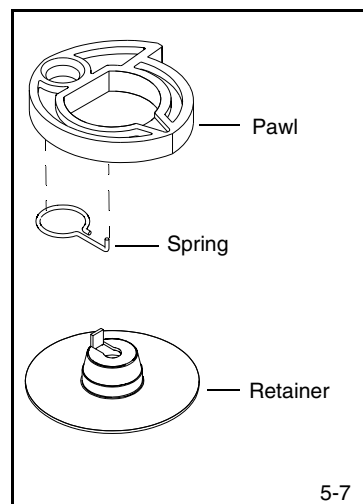
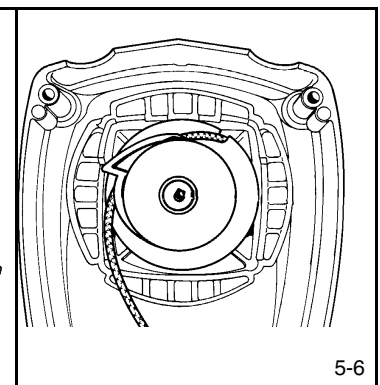
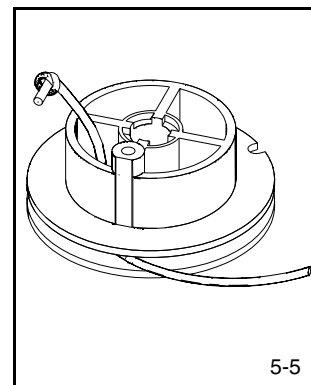
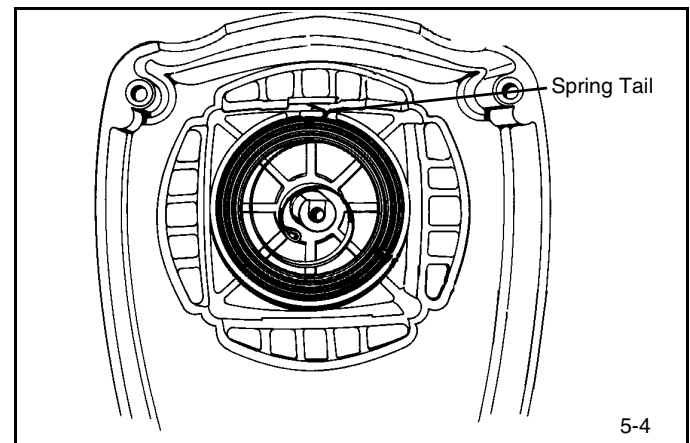
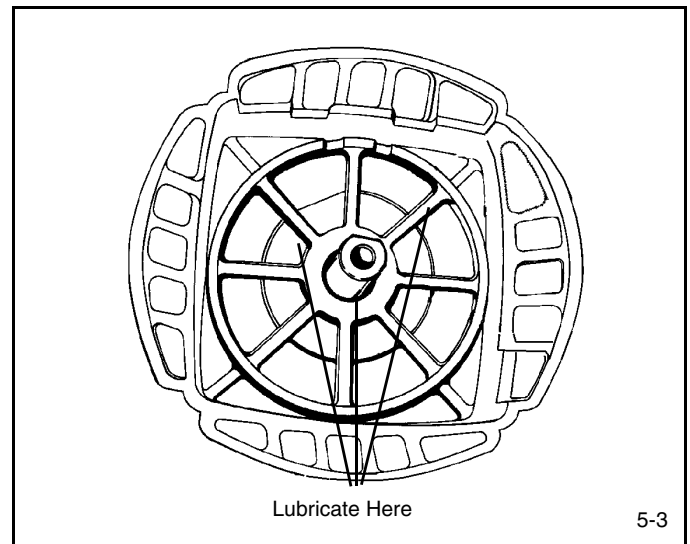

# CHAPTER 6 IGNITION

## GENERAL INFORMATION

All TC/TM engines are equipped with a solid state ignition module mounted outside the flywheel. The solid state ignition system consists of a flywheel magnet, charge coil, capacitor, a silicon controlled rectifier, a pulse transformer, trigger coil, high tension lead, and a spark plug. Some TC Type II modules also contain an ignition rev limiting device to prevent the engine from exceeding the maximum rpm. This type of limiter is used on mini-carts for safety reasons. All components except the spark plug and high tension lead are located in an encapsulated ignition module. The module is protected by epoxy filler from exposure to dirt and moisture. This system requires no maintenance other than checks of the high tension lead and spark plug.

## OPERATION

As the magnet in the flywheel rotates past the charge coil, electrical energy is produced in the module. The energy is stored in the capacitor (approx. 200 volts) until it is released by an electrical switch (SCR). As the magnet continues to rotate, it passes past a trigger coil where a low voltage signal is produced. This low voltage signal closes the SCR switch, allowing the energy stored in the capacitor to flow to a transformer where the voltage is increased from 200 volts to 25,000 volts. This voltage flows along the high tension lead to the spark plug where it arcs across the electrodes and ignites the air-fuel mixture (diag. 6-1).

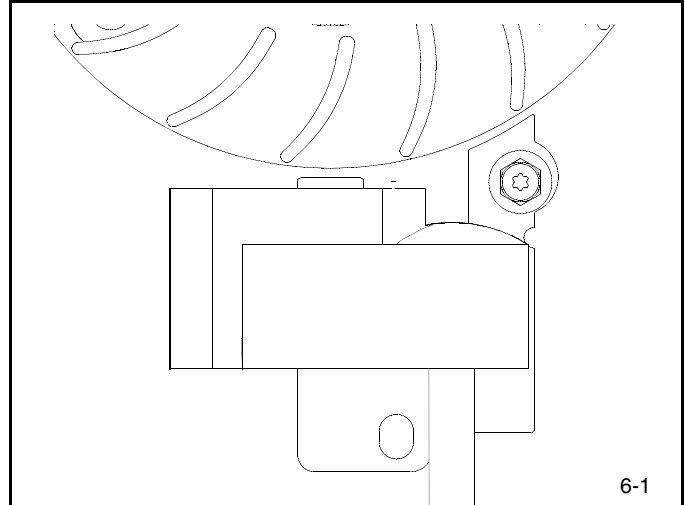

## COMPONENTS

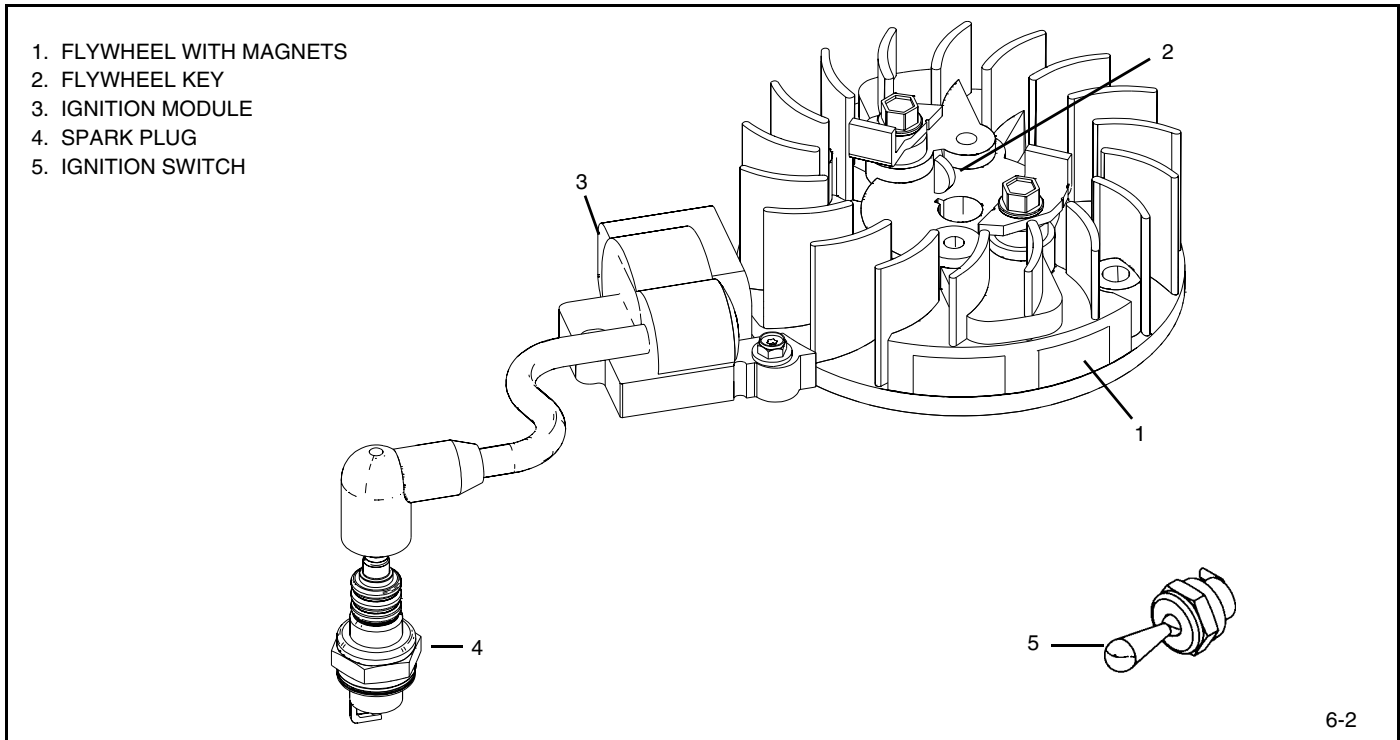

# IGNITION TROUBLESHOOTING

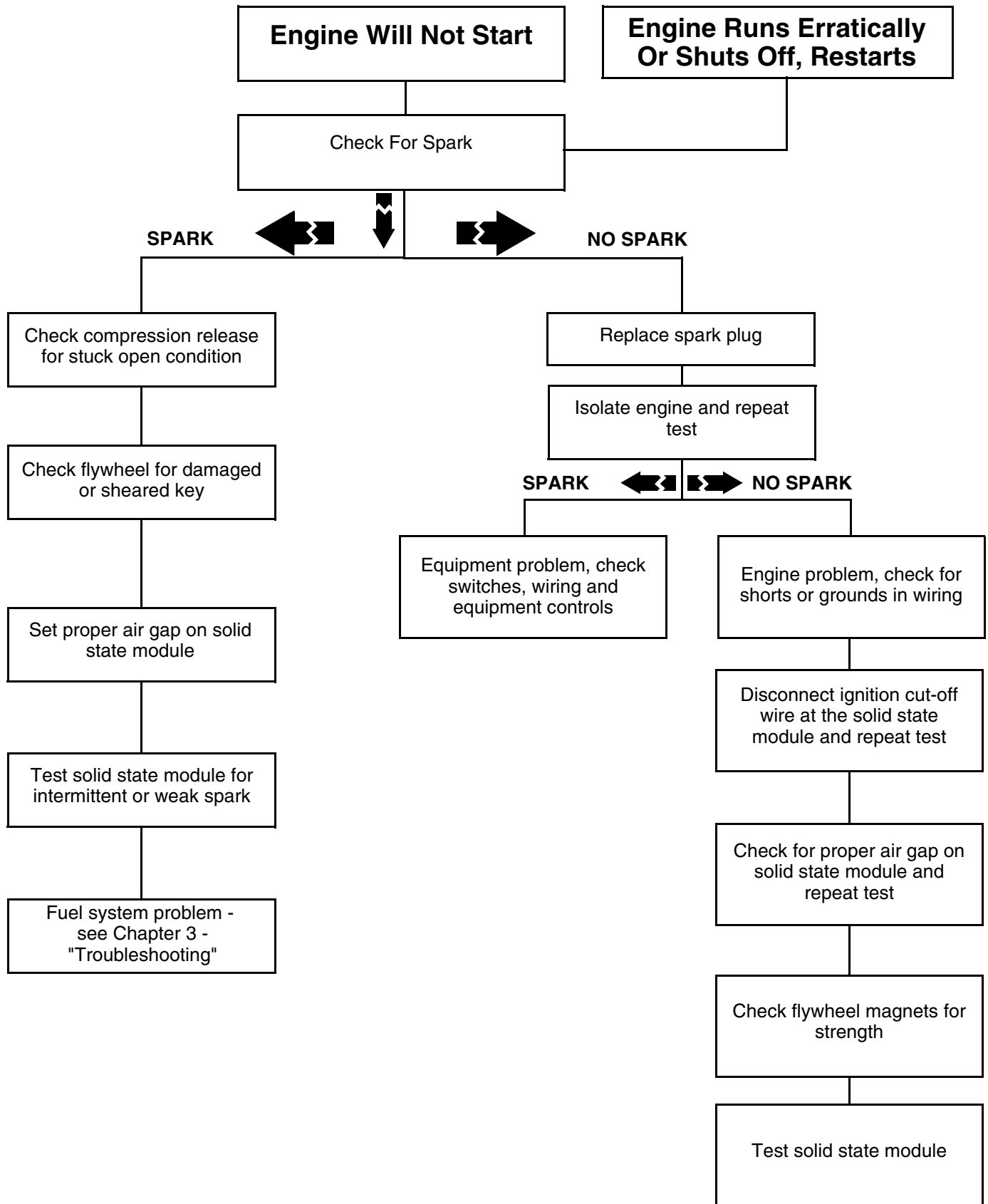

## TESTING

1. After repeated efforts to start the engine using the procedure listed in the operator's manual fail, check for spark by removing the high tension lead and removing the spark plug. Install a Tecumseh spark plug tester (part # 670366) and check for spark. If the spark is bright blue and fires every revolution, proceed to step # 2. If no spark, weak spark, or intermittent spark, proceed to step 5.
2. Check the spark plug for cracks in the porcelain, pitted or burned electrodes, excessive carbon build-up and proper air gap setting. Replace if questionable.
3. On TM engines, pull out on compression release and crank the engine over. If engine is not noticeably harder to crank over, replace or clean the compression release mechanism. See Chapter 7 under "Service".
4. Check the air gap between the ignition module and the flywheel magnet. See "Service" in this chapter.
5. Disconnect the ignition grounding lead at the ignition coil and crank the engine over. If spark occurs, check the ignition switch or the electrical wiring for shorting to ground. If no spark, test the ignition module using a coil tester or replace the ignition module.

## SERVICE

### AIR GAP SETTING

Timing on the solid state module is fixed. The air gap dimension between the laminations of the ignition module and the magnet is .0125" (.317 mm) (use gauge part # 670297) for all TC200 engines, TC300 Type II rotary mower engines and all TM. All other TC300 Type II applications require a .030" (.762 mm) air gap dimension (use gauge part # 670321). Loosen the module mounting bolts, insert the air gap gauge, hold the module against the flywheel magnets and torque the mounting screws to the specification. Remove the gauge and rotate the flywheel to check for any possible striking points. If none are found, the air gap is set correctly (diag. 6-3).

#### NOTE

*When using the 670321 gauge push the module tight to the flywheel before tightening.*

### SPARK PLUG SERVICE

Spark plugs should be removed, cleaned, and gap adjusted periodically. If the porcelain shows cracking, or the electrodes show evidence of pitting, burning, or excessive carbon build-up, replace the spark plug. **CAUTION!** Do not use a sand blaster to clean spark plugs. Microscopic particles left in the plug can score the engine cylinder during operation. Use solvent and a wire brush to clean the plug and compressed air to blow out completely.

Consult your Master Parts Catalog for the correct spark plug and replace if necessary. Set the spark plug gap at .030" (.762 mm) (diag. 6-4). Install the spark plug in the engine and tighten to 230 inch pounds (2.6 Nm) torque. If a torque wrench is not available, screw the spark plug in as far as possible by hand and use a spark plug wrench to turn the spark plug 1/8 to 1/4 of a turn more if using the old plug, and a 1/2 of a turn more if using a new spark plug.

#### NOTE

*When using the 670321 gauge, push the module tight to the flywheel before tightening.*

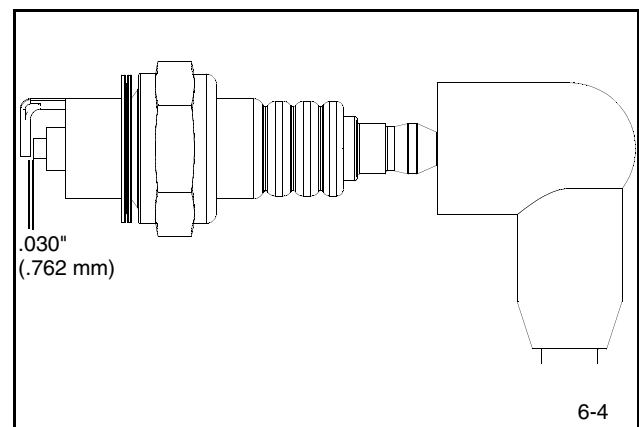
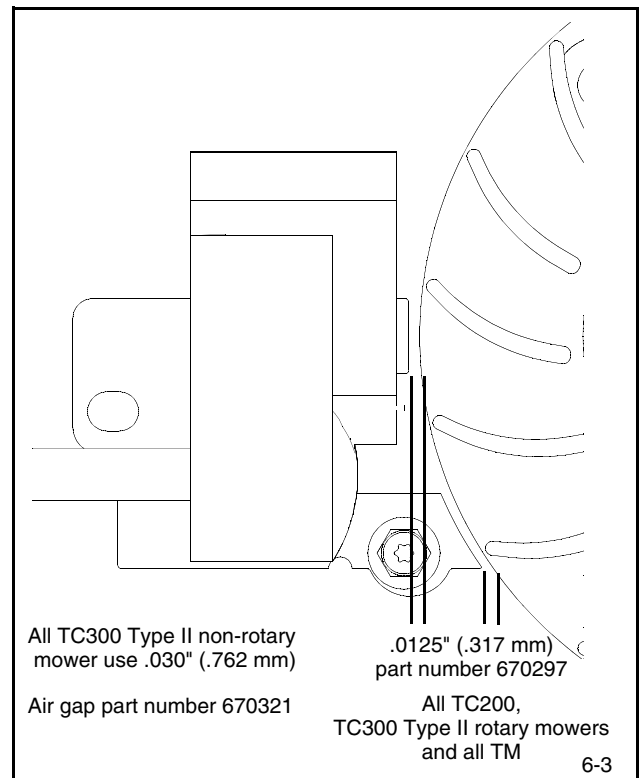

# CHAPTER 7 INTERNAL ENGINE AND CYLINDER

## GENERAL INFORMATION

TC/TM series engines use two cycle operation. Two cycle engines provide a higher horsepower to weight ratio than the same size four cycle engines. Two cycle engines use two piston strokes for a complete cycle that occurs every crankshaft revolution, while four cycle engines use four piston strokes and two crankshaft revolutions for a complete cycle.

Lubrication is accomplished through oil mixed in the fuel, and the air / fuel / oil mixture flows into the crankcase during upward piston travel. This mist lubricates all internal bearing surfaces.

## OPERATION

A low pressure area is created in the crankcase as the piston moves upward to compress the air / fuel mixture in the cylinder. When the piston moves far enough to uncover the intake port, the air / fuel mixture from the carburetor flows into the engine crankcase due to higher pressure atmospheric air. Just before the piston reaches top dead center (TDC), the spark plug ignites the air / fuel mixture in the cylinder.

The expanding combustion gases force the piston down. The downward piston travel causes a pressure build-up in the crankcase. The piston uncovers the exhaust port first followed by the transfer ports. The exhaust flows out the exhaust port while the pressurized air / fuel mixture enters the cylinder from the crankcase through the transfer ports. As the piston travels upward the sequence is repeated (diag. 7-1).

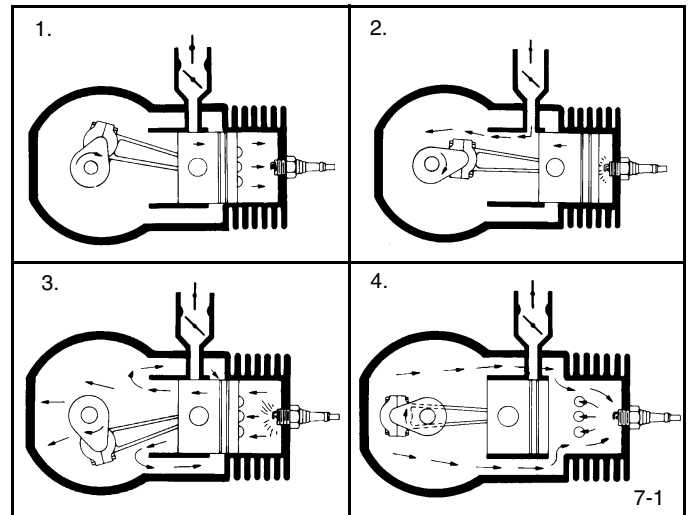

## MANUAL COMPRESSION RELEASE

TM engines are equipped with a manual compression release located in the head, near the spark plug. Pushing the yellow button of the compression release in to the 'OPEN' position lowers the cylinder compression to under 100 PSI. Lower compression requires less effort to be used for operation of the rewind starter which allows for easier starting. As the engine starts the pressure inside the cylinder builds and automatically "pops" the yellow button of the compression release out to the 'CLOSED' position allowing the engine to run at full compression. The yellow compression release button must be pushed in for each pull of the starter rope (diag. 7-2).

Over time, it may be necessary to remove the valve assembly for cleaning. The valve should only be removed when the engine is fully cooled. **DO NOT TRY TO DISASSEMBLE THE VALVE!** After removal from the engine, open the valve by depressing the yellow knob and spray with carb & choke cleaner. Allow to soak for 10 to 15 minutes and blow compressed air through the valve assembly. Repeat this process if the valve does not operate freely. Reinstall the valve and tighten to the recommended torque.

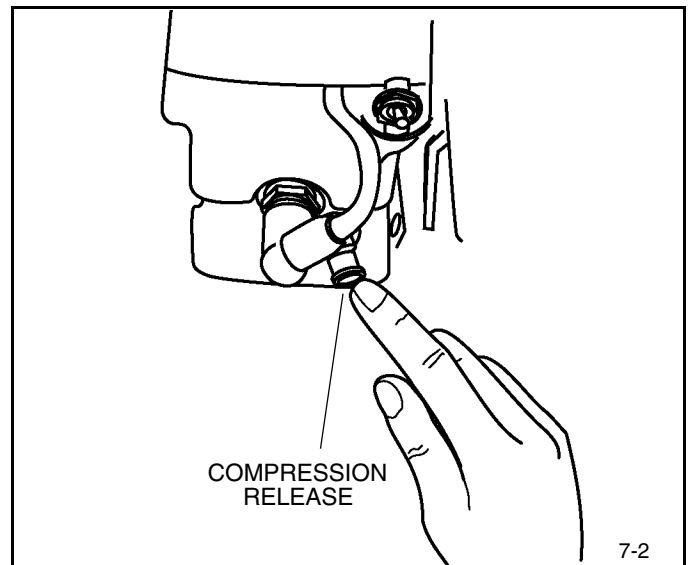

# COMPONENTS

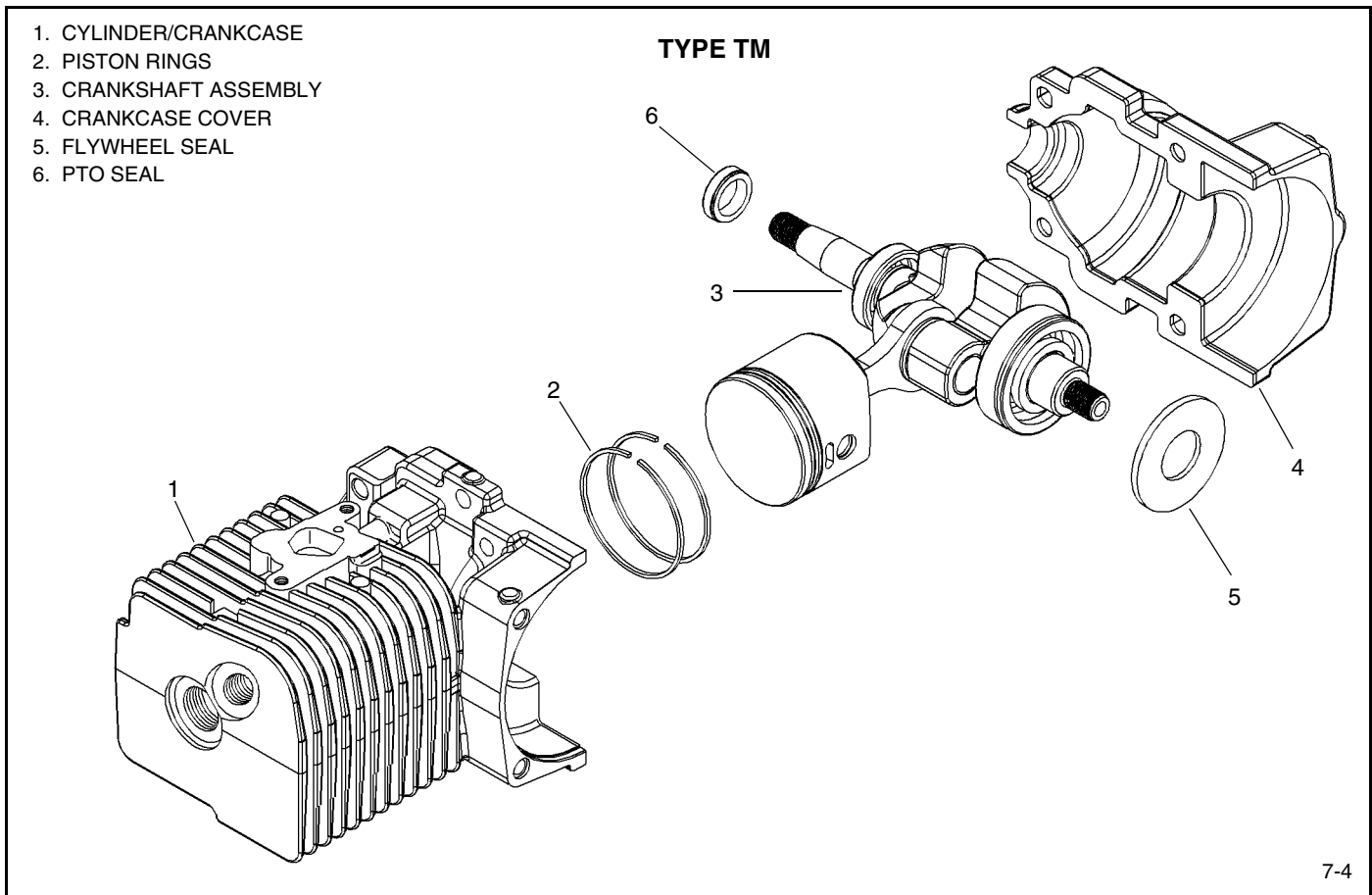
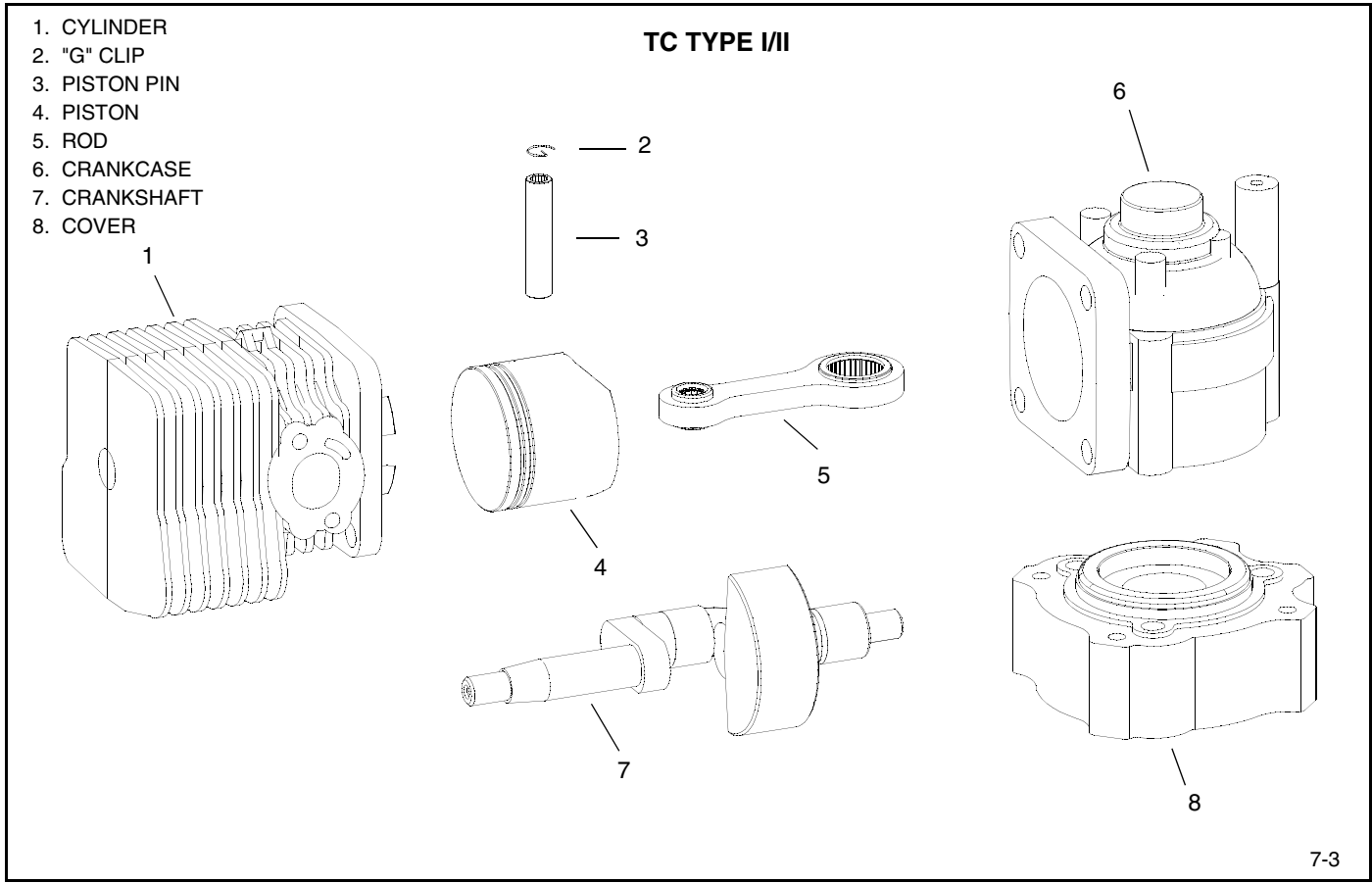

# TROUBLESHOOTING ENGINE OPERATION PROBLEMS

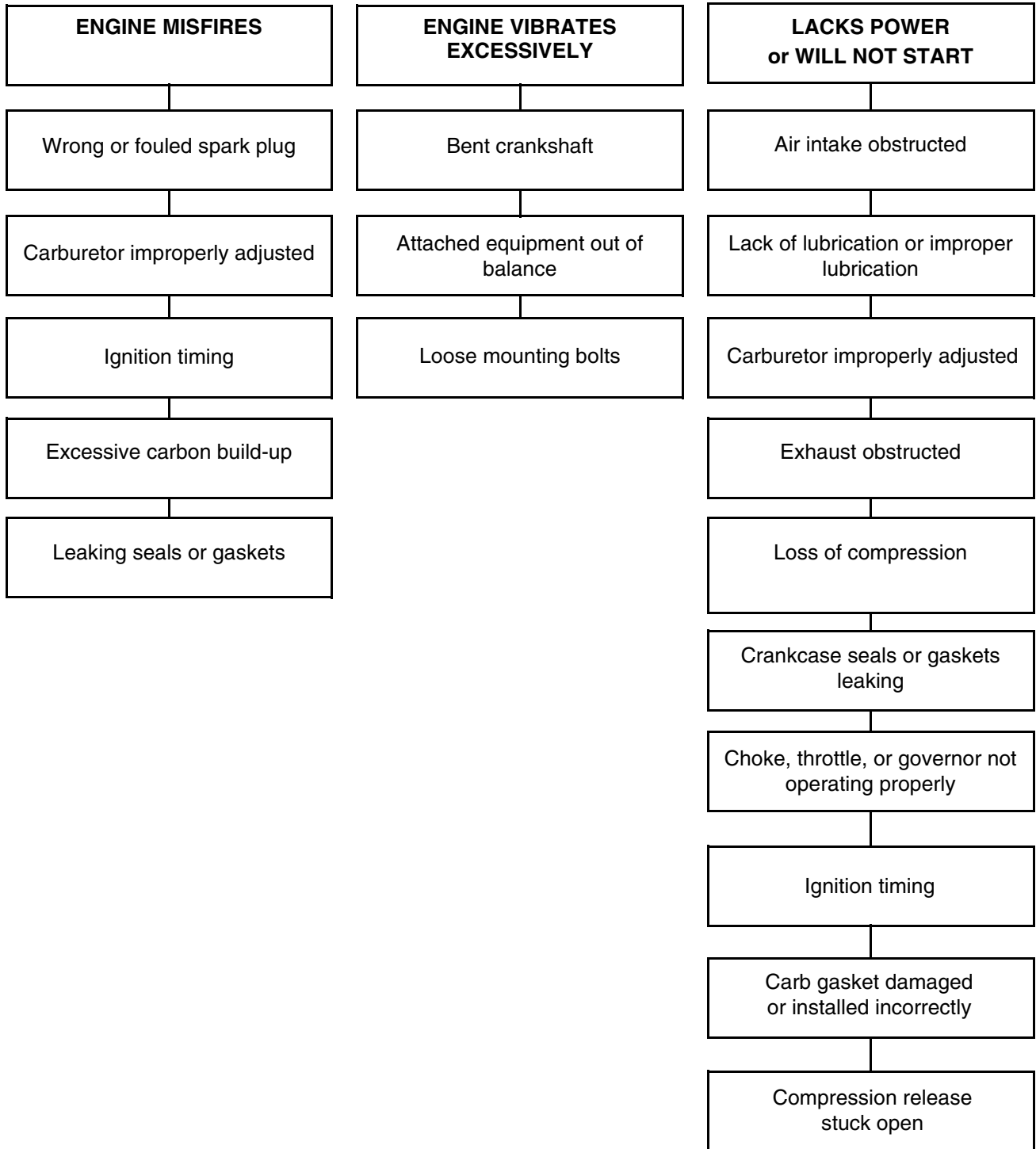

# TROUBLESHOOTING ENGINE OPERATION PROBLEMS

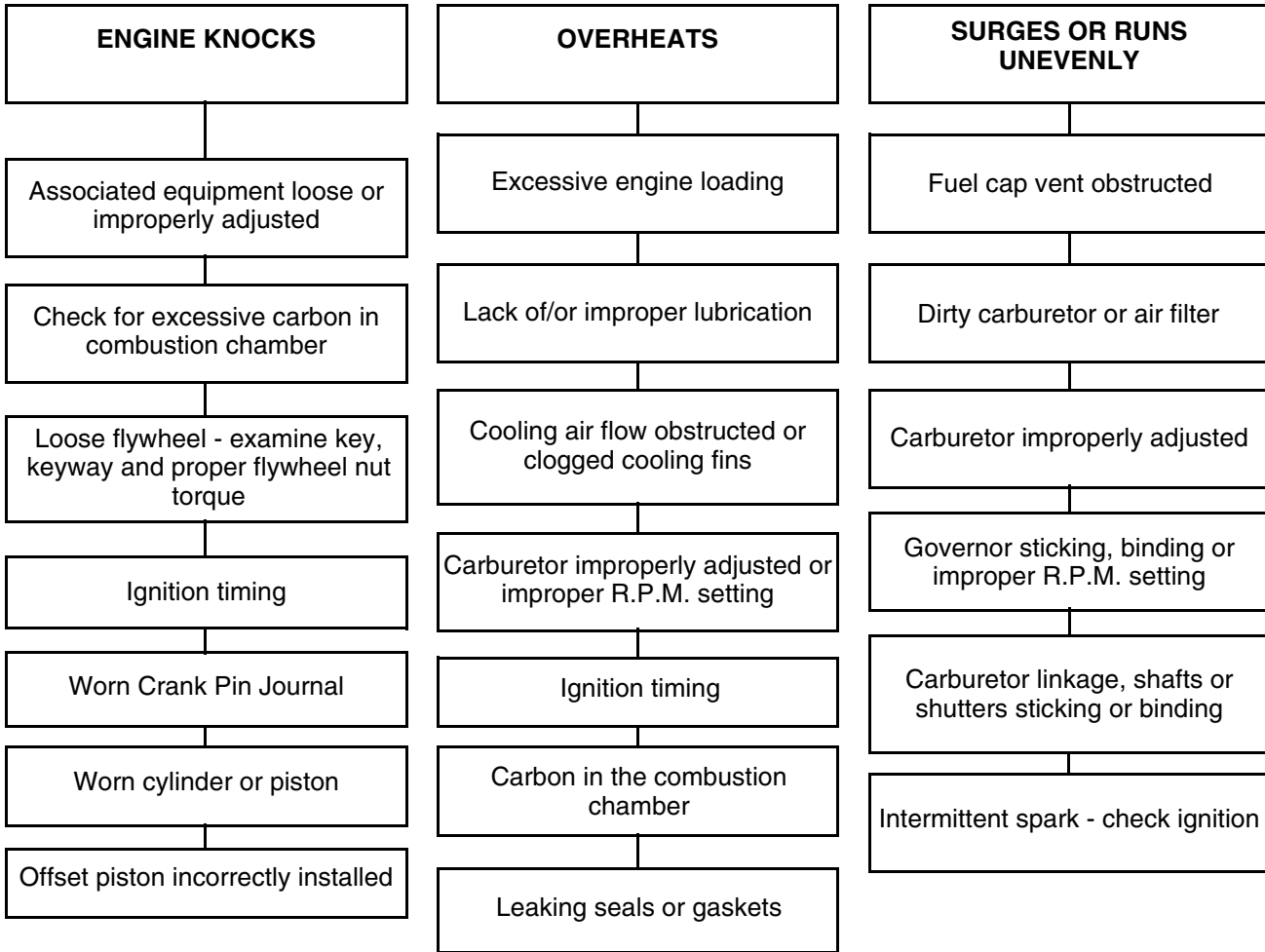



## **TESTING**

### **ENGINE KNOCKS**

1. Check the blade hub, adapter, crankshaft coupler or associated equipment for loose fit, or loose bolts. Re-install and re-torque the bolts to the proper torque.
2. Check the flywheel key and the flywheel and crankshaft keyway for wear or partial shearing. Replace if any damage is evident. Tighten the flywheel nut to the proper torque.
3. Check for the correct ignition module air gap. See Chapter 6 under "Service".
4. Remove the muffler and check for carbon build-up in the combustion chamber and exhaust port. Check the spark plug for the proper reach and heat range (correct spark plug for the engine). Clean carbon build-up if necessary.
5. Check the internal components (piston, cylinder, and crankshaft journals) for excessive clearance.

### **ENGINE OVERHEATS**

1. Make sure the engine is not being overloaded. Remove excess load.
2. Make sure the fuel mixture contains the correct ratio of certified 2-cycle oil to gasoline. Replace the fuel supply if questionable.
3. Check for clogged cooling fins or obstructions to the air flow. Remove the rewind assembly, clean and reinstall.
4. Check the engine R.P.M. setting using a Vibratach or other tachometer and compare it to the R.P.M. settings found on microfiche card # 30 or computer parts lookup according to the engine model and specification number. Adjust as necessary.
5. Remove the muffler and check for carbon build-up in the combustion chamber and exhaust port. Clean as necessary.
6. Check the carburetor for the correct idle mixture adjustment. Clean the carburetor if the problem persists. See Chapter 3 under "Service".
7. Check for the correct ignition module air gap. See Chapter 6 under "Service".
8. Inspect the intake gaskets, crankcase seals or gaskets for a leaking condition. Use a commercially available crankcase pressure tester and follow the tester's recommended test procedure. See "Disassembly Procedure" in this chapter for component removal.

### **SURGES OR RUNS UNEVENLY**

1. Check the fuel cap to make sure it is venting. Loosen the cap and retry engine operation.
2. Replace or clean the air filter if applicable.
3. Check the carburetor for the correct idle mixture adjustment. Clean the carburetor if the problem persists. See Chapter 3 under "Service".
4. Check the engine R.P.M. setting using a Vibratach or other tachometer and compare it to the R.P.M. settings found on microfiche card # 30 or computer parts lookup according to the engine model and specification number. Adjust as necessary.
5. Visually check all linkages. Check the governor spring for a stretched or damaged condition. Check the governor shaft, throttle shaft, and pivot points for binding.
6. Check the ignition module operation using a Tecumseh 670366 Spark Tester inserted in the high tension lead. Check for intermittent spark.
7. Inspect the intake gaskets, crankcase seals or gaskets for a leaking condition. Use a commercially available crankcase pressure tester and follow the tester's recommended test procedure. See "Disassembly Procedure" in this chapter for component removal.

### **ENGINE MISFIRES**

1. Check the spark plug for a fouled condition. Replace if questionable.
2. Check the carburetor for the proper adjustments. See "Pre-sets and Adjustments". See Chapter 3 under "Service".
3. Check the air gap dimension. Follow the procedure in Chapter 6 under "Service". Use an in-line spark tester to see if the problem is ignition related.

4. Check the flywheel key for partial shearing.
5. Remove the muffler to check for excessive carbon build-up in the combustion chamber or exhaust port.
6. Inspect the intake gaskets, crankcase seals or gaskets for a leaking condition. Use a commercially available crankcase pressure tester and follow the tester's recommended test procedure. See "Disassembly Procedure" in this chapter for component removal.

### **ENGINE VIBRATES EXCESSIVELY**

1. Remove the engine drive and check the attached equipment for an out of balance condition.
2. Check the engine mounting bolts, make sure they are tight.
3. Check the engine crankshaft on the P.T.O. end using a straight edge, square or dial indicator. Blades or adapters must be removed. Any deflection will cause a vibration problem.
4. Check the internal engine for bearing roughness or wear, crankshaft bearing journal wear, or a worn cylinder or piston.

### **LACKS POWER OR WILL NOT START**

1. Check the air intake for an obstruction (dirty filter, saturated filter, or other debris).
2. Check the exhaust for a restriction preventing proper exhaust flow.
3. Check the fuel / oil mixture for the gasoline being fresh and the proper amount and kind of oil used. Replace if questionable.
4. Visually check the operation of the throttle, air vane governor, and choke (if applicable) for restrictions preventing proper movement.
5. Check the carburetor for the correct idle mixture adjustment. Clean the carburetor if the problem persists. See Chapter 3 under "Service".
6. Inspect the intake gaskets, crankcase seals or gaskets for a leaking condition. Use a commercially available crankcase pressure tester and follow the tester's recommended test procedure. See "Disassembly Procedure" in this chapter for component removal.
7. Inspect the engine cylinder and ring(s) for a worn condition.
8. Check the flywheel key for partial shearing.
9. Check that the compression release moves outward to the closed position as soon as engine starts.

## **SERVICE**

### **GENERAL INFORMATION**

TC/TM engines do not have oversized pistons available. If the engine bore diameter exceeds the maximum engine specification and new installed rings exceed the maximum ring end gap, a new short block or engine will be necessary. Engines built with needle bearing P.T.O. main bearings have been upgraded to be serviced with P.T.O. ball bearing replacements. Gaskets have replaced Loctite sealant between the engine cylinder and the crankcase. Crankcases that used Loctite sealant between the cylinder cover and the engine crankcase have been upgraded to use an "O" ring in a machined channel. TM engines have been upgraded to include a manual compression release. Engines requiring replacement of the cylinder, cylinder cover, crankcase, or piston and rod assembly may require the replacement of the short block or a complete engine. Consult the Tecumseh Master Parts Manual, Microfiche or Electronic Parts Catalog using the engine model and specification number for replacement part information.

### **DISASSEMBLY PROCEDURE—TC TYPE I AND TC TYPE II**

1. Remove the high tension lead boot from the spark plug by twisting and pulling.
2. Remove the spark plug using a 3/4" (19 mm) deep well socket.
3. Drain the fuel from the tank by sliding the fuel line clamp off the carburetor fuel fitting (TC Type I) or fuel tank fitting (TC Type II), twist and pull the fuel line off and drain the fuel into an approved container outdoors and away from any open flame or combustion source. be sure the engine is cool.



**WARNING**

To avoid death or serious injury, DO NOT pour fuel from engine or siphon fuel by mouth.

4. Remove the two hex nuts on the carburetor studs and remove the air cleaner assembly. On TC Type II engines, remove the two screws on the filter cover, the filter element(s), and then the two hex nuts on the carburetor studs. If the carburetor stud loosens; try retightening the hex nuts first, then loosen the nuts.
5. Remove the fuel tank on TC Type I engines by unhooking the tank spring. For TC Type II engines, remove the self-locking nut and washer on the blower housing stud and remove the fuel tank.
6. Remove the rewind starter assembly by removing three machine screws (diag. 7-5). Remove the rubber plugs.
7. Remove the ignition grounding lead off the ignition module and remove the ignition module using a 1/4" socket or Torx T15 drive.
8. Use the strap wrench (part # 670305) to hold the flywheel and loosen the flywheel nut until it is flush with the end of the crankshaft.
9. Use flywheel puller (part # 670299) to pop the flywheel off the crankshaft taper, unthread and remove the puller. Remove the flywheel nut, washer, flywheel and flywheel key (diag. 7-6).

**NOTE**

*DO NOT use a knock-off tool on the crankshaft when removing the flywheel. Permanent engine damage may result.*

10. Mark or note the location of the throttle link, governor spring hook-up, and speed control to aid in assembly. Remove the carburetor, spacer, gaskets, and air baffle if equipped using a 1/4" socket on the carburetor studs.
11. Remove the blower housing base by removing the three 5/16" hex head screws (diag. 7-7).
12. Attach the engine tool holder (part # 670300) to the crankcase using the three removed blower housing base hex head screws. Place tool in a bench vise (diag. 7-8).
13. On TC Type II engines, remove the muffler using a 12" (304 mm) piece of heavy gauge wire with a 1/4" (6.31 mm) hook on one end to pull the muffler spring off (diag. 7-9). A diagram of the wire hook is in the tool section of this manual. On TC Type II engines, remove the shoulder bolts holding the muffler on.
14. Note or mark the location of the cylinder to the crankcase and remove the four Torx bolts holding the cylinder to the crankcase using a six inch long Torx T30 driver (part # 670320). Pull the cylinder off squarely using caution so the rod does not bend. Use a 3/8" open end wrench to loosen the four cylinder nuts on early production type I engines (diag. 7-10).
15. Insert seal protector (part # 670301) to protect the flywheel end oil seal and seal protector (part # 670303) for the P.T.O. end oil seal (diag. 7-10).
16. Remove the crankcase cover screws and remove the cover. On TC Type II engines with a ball bearing in the cover, the cover and crankshaft will be removed as an assembly.

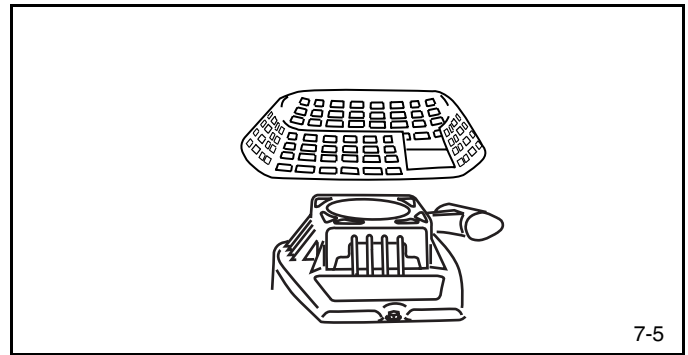

7-5

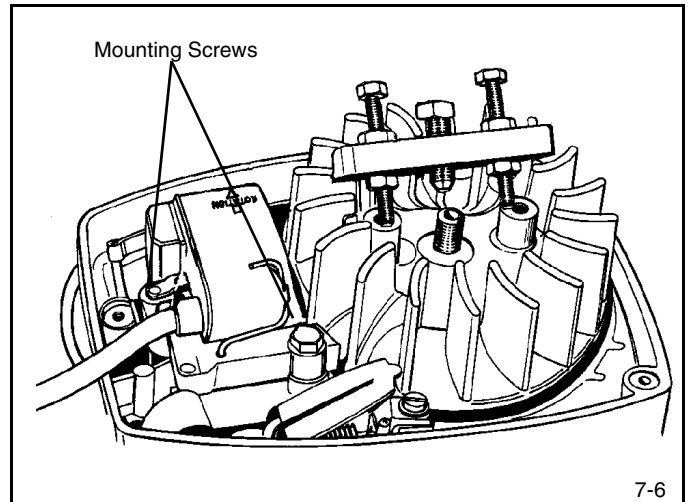

7-6

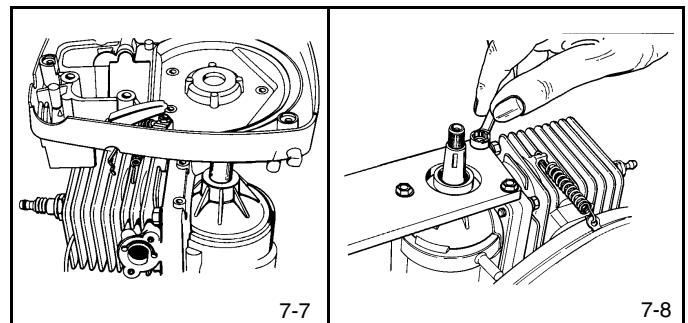

7-7

7-8

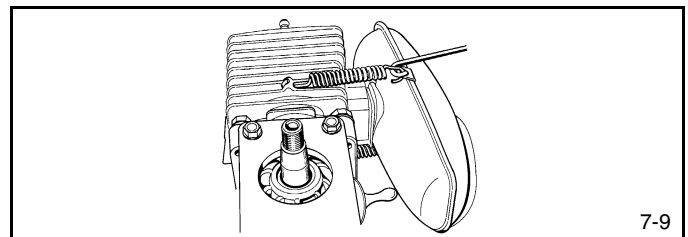

7-9

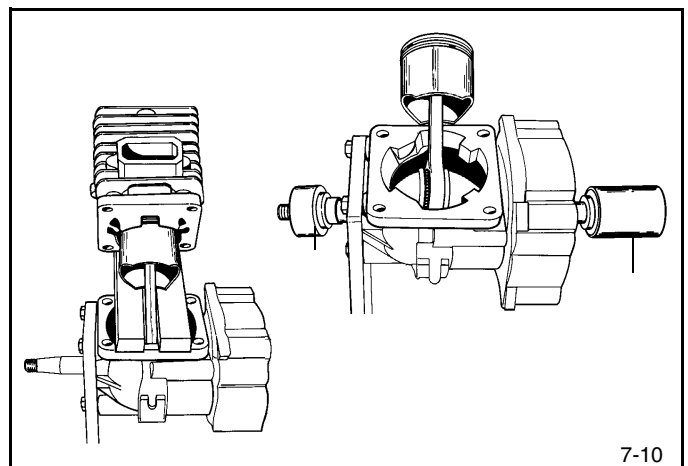

7-10

17. Turn the crankshaft to the 90° past the top dead center (T.D.C.) position and remove the crankshaft out of the crankcase opening while sliding the connecting rod off the crankpin and crankshaft. TC Type II engines use a pressed in mechanically retained needle bearing in the connecting rod. Older TC engines use loose crankpin needle bearings, make sure to collect all 23 needle bearings. Engines built after Aug. 1995 may also use loose needle bearings (grease retained), 36 needles are required (diag. 7-11).

18. Use a bearing splitter and an arbor press to remove the ball bearing and cover assembly from the crankshaft on TC Type II if necessary.

19. Remove the oil seals by supporting the area around the seal and using a small punch or screwdriver to drive out the seal.

## BEARING AND SEAL SERVICE—TC TYPE I AND TC TYPE II

The crankcase and crankcase cover oil seals can be removed by prying out or tapping out with a screwdriver. On older TC engines, a retainer ring must be removed with a pick before the crankcase bearing can be pressed out (diag. 7-12).

Remove the needle bearing by using the bearing installer tool (part # 670302) inserted from the outside to drive the bearing out.

To install a new bearing in the engine crankcase, place a new caged needle bearing on the installation tool (part # 670302). Use bearing installation tool (part # 670304A) for installing the crankcase cover caged needle bearing. Place the printed side of the bearing toward the installation tool. Lightly oil the outside of the bearing and the crankcase bearing bore. Press the bearing into the crankcase until the tool is flush with the crankcase or cover housing. Insert the retainer ring if applicable (diag. 7-13).

Install a new crankcase oil seal using seal protector / installer (part # 670301). Install the crankcase cover oil seal using seal installer (part # 670303). The metal case of the seal goes onto the seal protector first. Lightly oil the outside of the seal. Press the tool and seal in until the tool is flush with the crankcase (diag. 7-14).

Later production TC engines have a step machined in the crankcase and crankcase cover bearing area. This change eliminated the need for a retainer ring. The bearing and seal installation tools (part # 670302, 670303, 670304A) can be used with either style of crankcase cover. The installation tools place the bearing in the cover or the crankcase to the proper depth.

Models equipped with a ball bearing in the crankcase cover can have the ball bearing removed using an arbor press with support placed near the bearing diameter. Press the bearing out of the cover from the outside, pushing the bearing away from the machined step.

A new crankcase cover ball bearing can be installed using an arbor press. Press the bearing in until the bearing is flush and the bearing contacts the machined step.

Seal protector / installer part # 670303 should be used to install a new oil seal in the crankcase cover.

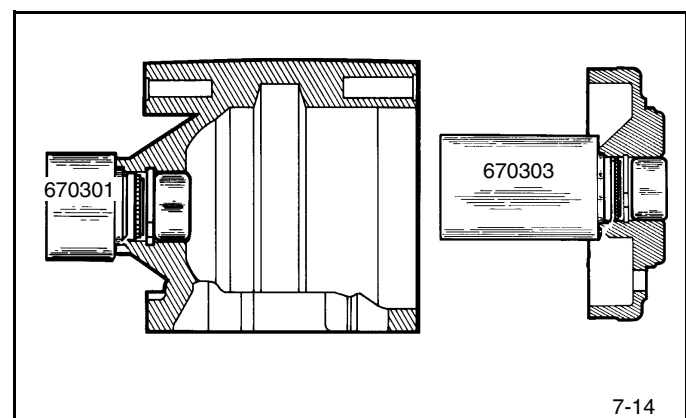
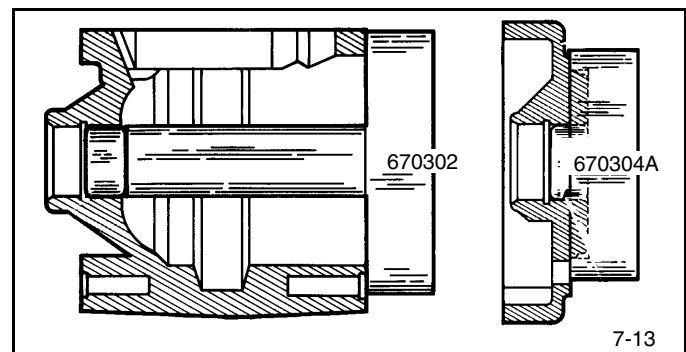
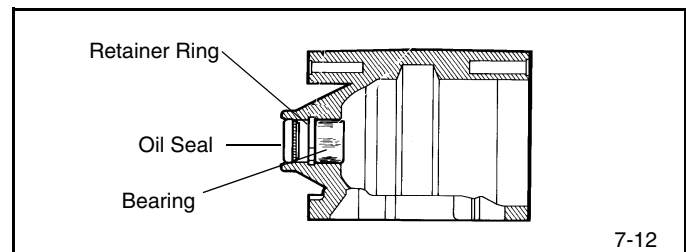
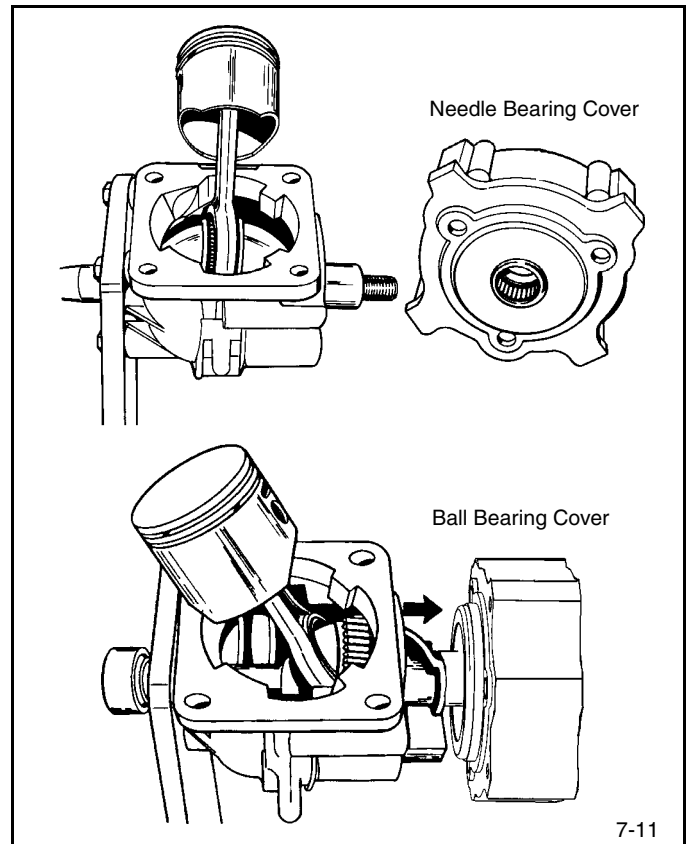

## ASSEMBLY—TC TYPE I AND TC TYPE II

1. Remove old gasket material. Be careful not to damage, scratch or burr the sealing surfaces. Clean the crankcase, cylinder, piston assembly, crankshaft, and crankcase cover using cleaning solvent and blow dry with compressed air (diag. 7-15).
2. On TC Type II engines with a ball bearing on the P.T.O. end, assemble the crankshaft into the cylinder cover. Place a drop of 680 Loctite in the crankshaft groove, position supports under the cylinder cover, and using an arbor press, press the shaft into the bearing until it bottoms on the bearing.
3. Install the crankshaft and piston assembly into the crankcase at the same time. Install a new bearing strip on the crankpin or grease retain the loose needles if applicable. If the piston has an arrow on top, the arrow must point toward the exhaust port side of the engine. If the piston does not have an arrow, the piston and rod assembly must have the wrist pin retainer facing the P.T.O. side of the engine. Position the crankshaft crankpin at 90° to top dead center while sliding the piston assembly over the crankshaft. Do not use force positioning the assembly (diag. 7-16).
4. Install either a new crankcase cover "O" ring and lightly oil if one was originally used, or apply Loctite # 515 gasket sealant eliminator (Tecumseh part # 510334) to the crankcase surface to seal the crankcase cover. Apply a continuous bead of Loctite (.062" [1.57 mm] bead width) on the crankcase surface. The bead must completely surround the tapped holes for the cover. Loctite must not enter the crankcase (diag. 7-17).
5. Align the crankcase cover to the proper position using the mounting bolts as a guide. Do not allow the cover to rotate while assembling. Tighten the bolts to achieve 70 - 100 inch pounds (7.9 Nm - 11.3 Nm) of torque.
6. Install the crankcase oil seal using seal protector (part # 670301) on crankcase oil seal. The metal case of the seal must face toward the tool. Press the tool flush to the crankcase.
7. Install crankcase cover oil seal using seal protector / installer part # 670303 to protect the oil seal during installation. The metal case of the seal must face toward the tool. Press the tool flush to the cover.
8. Apply mineral spirits or kerosene to the crankpin bearing and rotate the crankshaft to dissolve the wax of a new needle bearing strip. Apply engine oil and rotate the crankshaft to displace the grease used to hold the needles in place on grease retained crankpin bearings.
9. Install cylinder gasket (notched edge toward the cylinder cover and the exhaust port side of cylinder), or apply a .062" (1.57 mm) bead of Loctite # 515 to the cylinder crankcase surface if Loctite was originally used. The Loctite bead must completely surround the cylinder bolt holes. Loctite must not be allowed to enter the crankcase.

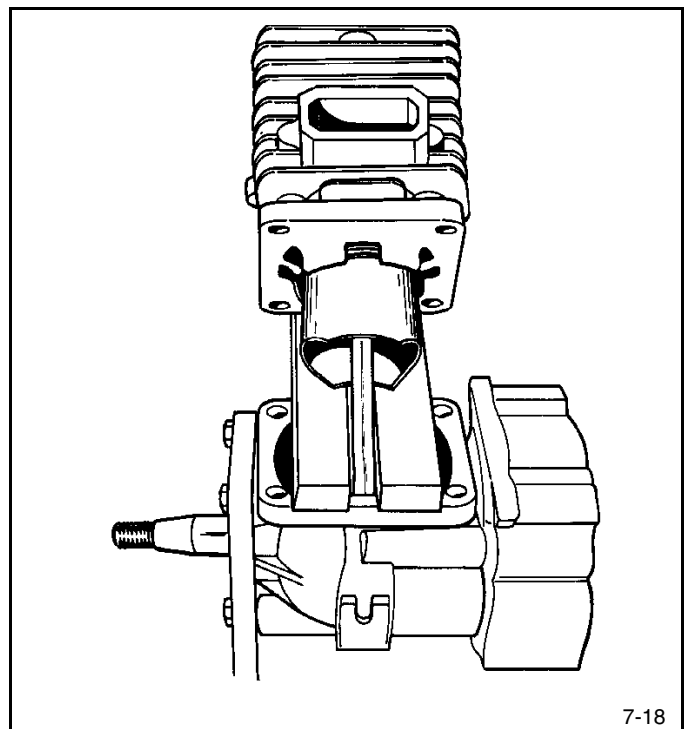
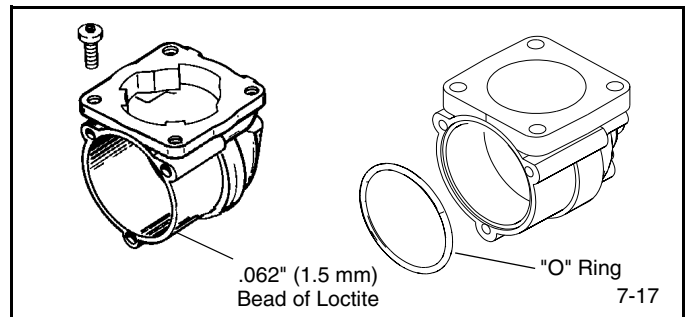
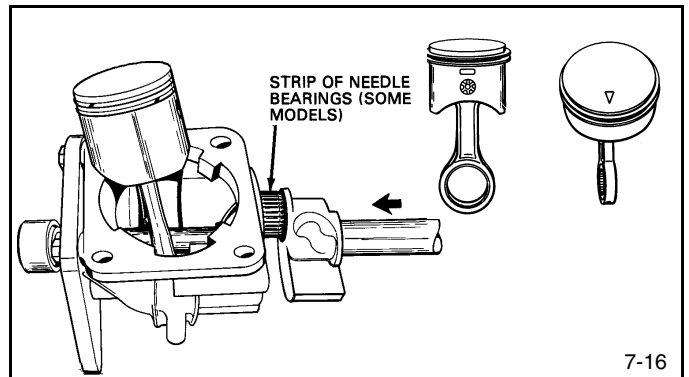
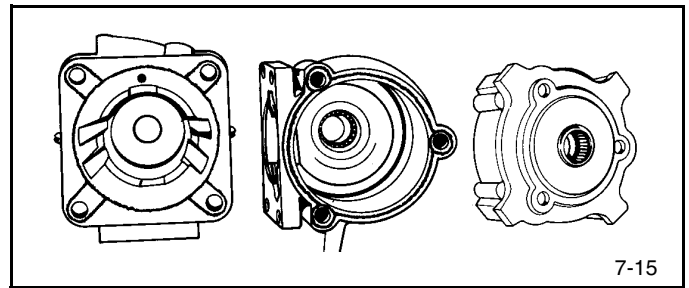

10. Use a piston and rod holder (dimensions are in Chapter 9 tool section) to prevent damage to the rod when installing the cylinder. Make sure the ring end gaps are staggered and the cylinder is in the correct position. Use fingers or ring compressor (part # 670391) (do not align the opening in the ring compressor with ring end gaps) to compress the piston rings and push the cylinder onto the piston. Remove ring compressor by sliding opening of tool past the connecting rod. Do not rotate or twist the cylinder (diag. 7-18).

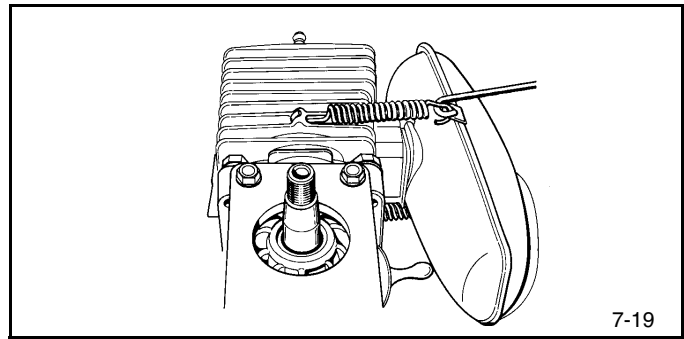

11. Install Torx bolts and alternately torque the bolts to 80-95 inch pounds (9.04 Nm - 10.7 Nm), or on engines with studs instead of bolts: push the cylinder down to a depth where the nuts can be started on the studs. Finger tighten the nuts, use a wrench to snug, and torque the nuts to 70 - 100 inch pounds (7.9 Nm - 11.3 Nm) using a crowfoot on the torque wrench.

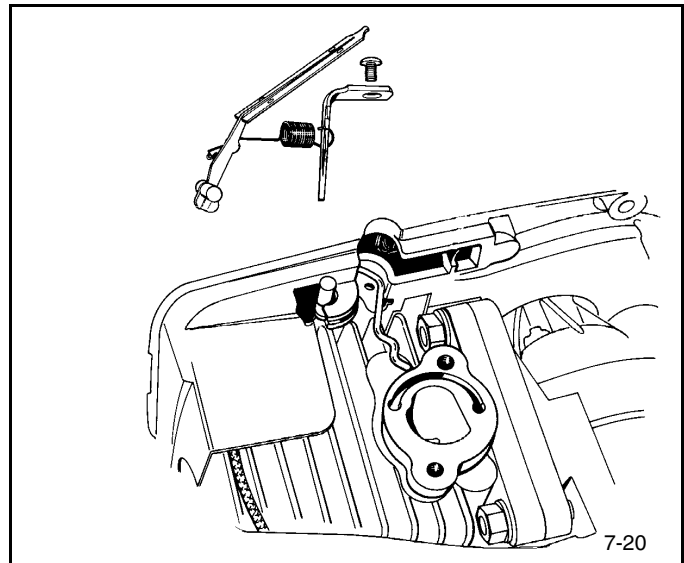

12. Install the exhaust gasket, muffler, spark arrestor if applicable, bolts or muffler springs. Torque the muffler bolts to 85 - 105 inch pounds (9.6 Nm - 11.8 Nm) of torque if applicable. The longer ends of the springs hook into the bosses on the cylinder. Use heavy gauge wire (as shown in the tool section) to stretch and hook the muffler springs (diag. 7-19). Install the muffler heat shield if applicable. Remove the engine holder.

13. Attach the blower housing base using the three screws removed from the engine holder and torque the screws to 30-40 inch pounds (3.3 Nm - 4.5 Nm).

14. On TC Type I models, install the governor air vane assembly into the blower housing base as shown. Some models use a spring clip to hold the air vane in position. Insert and tighten the speed adjusting lever hold-down screw to the blower housing base. Hook the long end of the governor spring into the notch on the neck of the air vane. The short end hooks into the hole in the speed adjusting lever as shown (diag. 7-20).

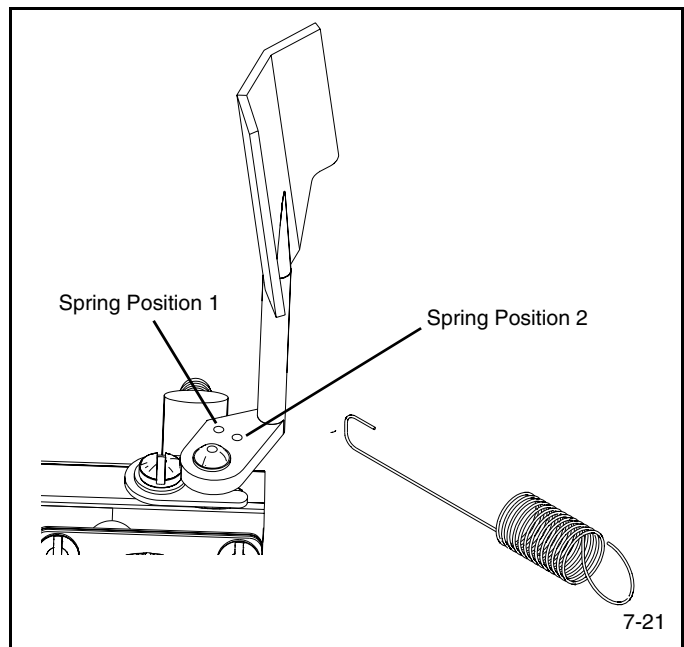

15. Insert one end of the throttle link in the hole in the air vane and the other end in the hole closest to the throttle shaft. Install the air baffle (if equipped), gaskets, spacer, and carburetor. (See Carburetor Assembly instructions on page 22, Chapter 3.) Assemble gaskets correctly, do not plug the pulse passage. Torque the bolts to 30-40 inch pounds (3.3 Nm - 4.5 Nm). On TC Type II models, attach and torque the air vane to the carburetor throttle shaft before installation. Hook the long end of the governor spring in the hole in the air vane and the short end in the hole in the speed control bracket. The spring hooks from beneath both components. Use the illustration (diag. 7-21) and the following spring location chart if the air vane has more than one governor spring hole and uses a colored spring with a square and round end.

SPRING COLOR	SPRING POSITION
Orange or Green	1
Pink, Red, or Black	2

16. Install the flywheel key and flywheel. Install the flywheel washer and nut, use a strapwrench (part # 670305) to hold the flywheel, and torque the nut to 15-20 foot pounds (1.6 Nm - 2.2 Nm).
17. Attach the ignition module, use the proper air gap gauge between the flywheel magnets and the module laminations (use .0125" (.317 mm) gauge part # 670297 for all TC200 Type I engines, TC300 Type II rotary mower engines and all TM. All other TC300 Type II applications require a .030" (.762 mm) air gap dimension (use gauge part # 670321). Torque the module mounting screws to 30-40 inch pounds (3.3 Nm - 4.5 Nm). Remove the air gap gauge, rotate the flywheel to assure it does not strike the ignition module. Attach ignition grounding lead to the module terminal (diag. 7-22).

**NOTE**

*When using .030" (.762 mm) air gap gauge, it is critical to push the module against the flywheel magnet before tightening the mounting screw.*

18. Install the blower housing and rewind assembly. Replace the debris guard if applicable.
19. Connect the fuel line at the carburetor, position the fuel line clamp on the fuel fitting, and attach the fuel tank to the engine using the mounting spring. On TC Type II engines, hook the upper fuel tank mounting tab over the blower housing stud and the carburetor studs. Make sure the "O" ring is in position between the fuel tank and the carburetor. Tighten the retaining nuts, install filter(s), and attach the air cleaner cover.
20. Reset the governor and/or speed control using the procedure in Chapter 4 under "Service".
21. Install the spark plug and connect the high tension lead.

**DISASSEMBLY PROCEDURE—TM**

1. Remove the high tension lead boot from the spark plug by twisting and pulling.
2. Remove the spark plug using a 3/4" (19 mm) deep well socket.
3. Drain the fuel from the tank by sliding the fuel line clamp off the fuel tank fitting, twist and pull the fuel line off and drain the fuel into an approved container outdoors and away from any open flame or combustion source. Be sure engine is cool.

**⚠WARNING**

To avoid death or serious injury, DO NOT pour fuel from engine or siphon fuel by mouth.

4. Remove the two screws on the filter cover, the filter element(s), and then the two hex nuts and spacers, if equipped on the carburetor studs (diag. 7-23).
5. Remove the self-locking nut and washer on the blower housing and remove the fuel tank.

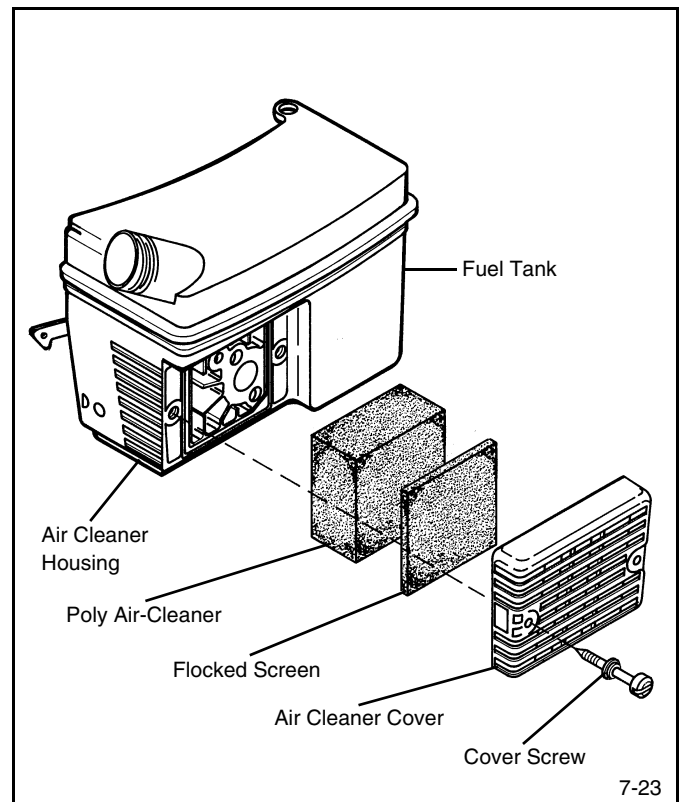
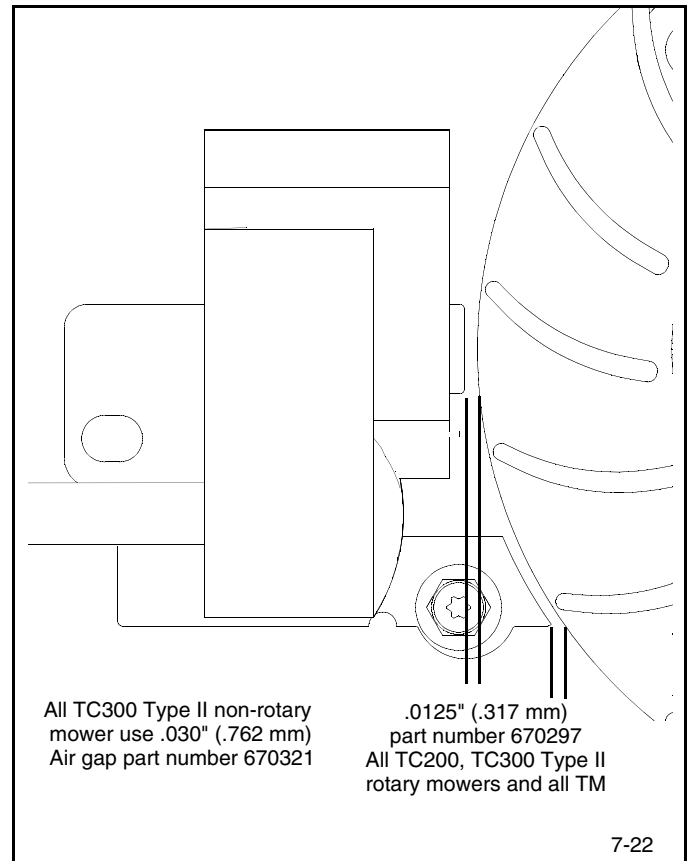

6. Remove the rewind starter assembly by removing three machine screws (diag. 7-24).
7. Remove the ignition grounding lead off the ignition module and remove the ignition module using a 1/4" socket or Torx T15 drive.
8. Use the strap wrench (part # 670305) to hold the flywheel and loosen the flywheel nut until it is flush with the end of the crankshaft.
9. Use flywheel puller (part # 670299) to pop the flywheel off the crankshaft taper, unthread and remove the puller. Remove the flywheel nut, washer, flywheel and flywheel key (diag. 7-25).

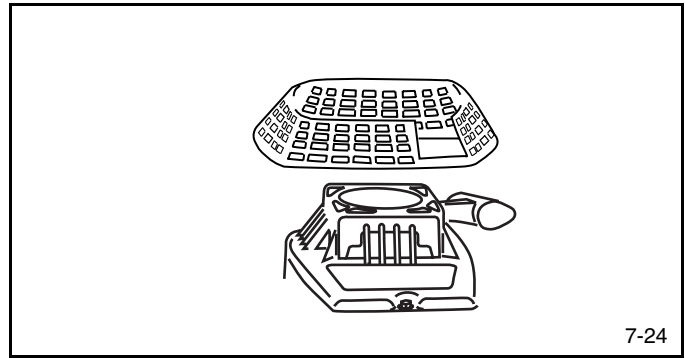

**NOTE**

*Do not use a knock-off tool on the crankshaft when removing the flywheel. Permanent engine damage may result.*

10. Mark or note the location of the throttle link, governor spring hook-up, and speed control to aid in assembly. Remove the carburetor, spacer, gaskets, and air baffle if equipped.
11. Remove the blower housing base by removing the three 5/16" hex head screws and if equipped, the two 1/4" hex head screws for the muffler heat shield.
12. Place engine in a soft-jawed bench vise.

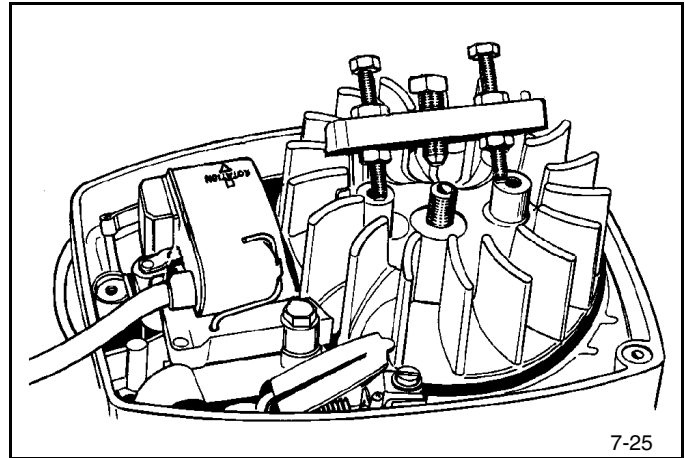

**NOTE**

*DO NOT over tighten engine in vise. Permanent engine damage may result.*

13. Remove the two shoulder bolts holding the muffler and remove the muffler.
14. Remove the compression release valve using a 1/2" deep socket.
15. Remove the four Torx bolts holding the crankcase halves together using a Torx T30 driver (part # 670320). Remove the crankcase cover (diag. 7-26).
16. Pull the crankshaft, piston and rod assembly squarely out of the cylinder using caution so the rod does not bend (diag. 7-27).

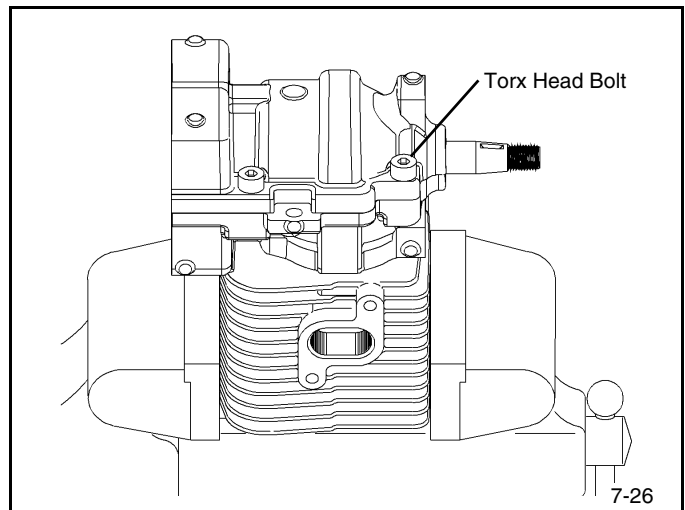

17. Remove both oil seals from the crankshaft.

**BEARING AND SEAL SERVICE—TM**

The crankshaft bearings can only be replaced as part of the crankshaft, piston and rod assembly. Follow the "Disassembly" and "Assembly" procedures for TM engines.

The crankshaft oil seals can be replaced by separating the crankcase and cover. Follow the "Disassembly" and "Assembly" procedures for TM engines.

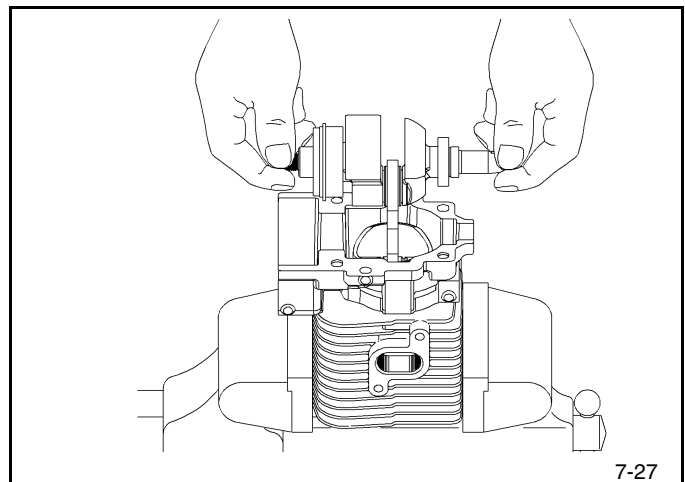



## ASSEMBLY—TM

1. Remove old gasket material. Be careful not to damage, scratch or burr the sealing surfaces. Clean the crankcase, cylinder, piston assembly, crankshaft, and crankcase cover using cleaning solvent and blow dry with compressed air.
2. Install the crankcase flywheel end oil seal using seal protector part # 670301 on the seal. The oil lip/spring side of the seal must face toward the crankshaft bearing. Press until the oil seal touches the bearing.
3. Install crankcase PTO end oil seal using seal protector / installer part # 670275 to protect the seal during installation. The oil lip/spring side of the seal must face toward the crankshaft bearing. Press until the oil seal touches the bearing.

### NOTE

*Lube piston skirt and cylinder bore with clean two-cycle oil prior to piston installation.*

4. Place ring compressor (part # 670391) in the cylinder with the outer taper centered in the cylinder and the opening in ring compressor facing the PTO end. Make sure the ring end gaps are staggered and away from the opening in the ring compressor. Use ring compressor to compress the piston rings and push the piston into the cylinder while aligning the center line of the crankshaft with crankcase (diag. 7-28).
5. Rotate the ring compressor to align the opening with the connecting rod and remove the ring compressor (diag. 7-29).
6. Do not rotate or twist the crankshaft assembly. Insert the piston until the crankshaft bearings seat in the crankcase. PTO end bearing retaining ring must seat in groove of crankcase (diag. 7-30).

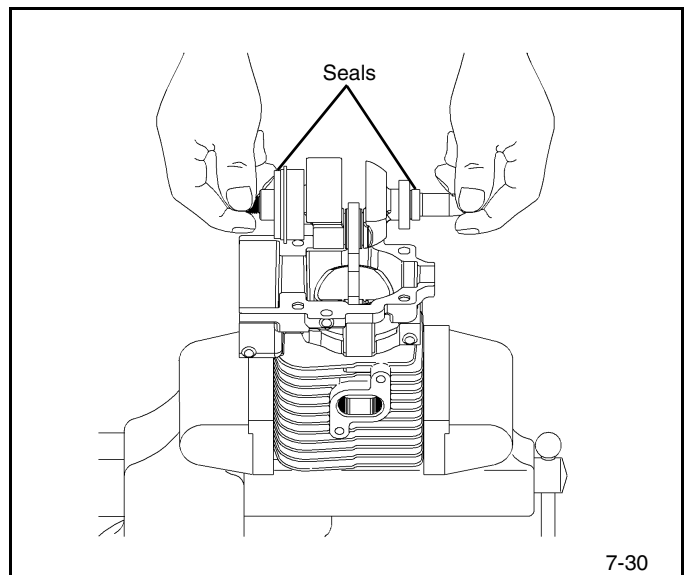
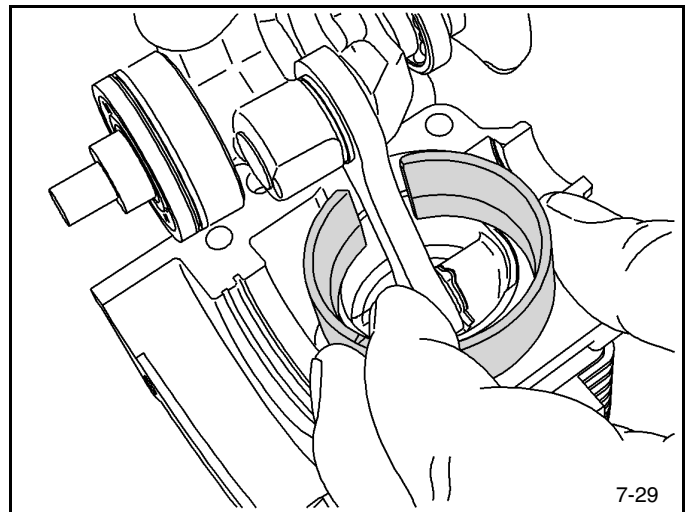
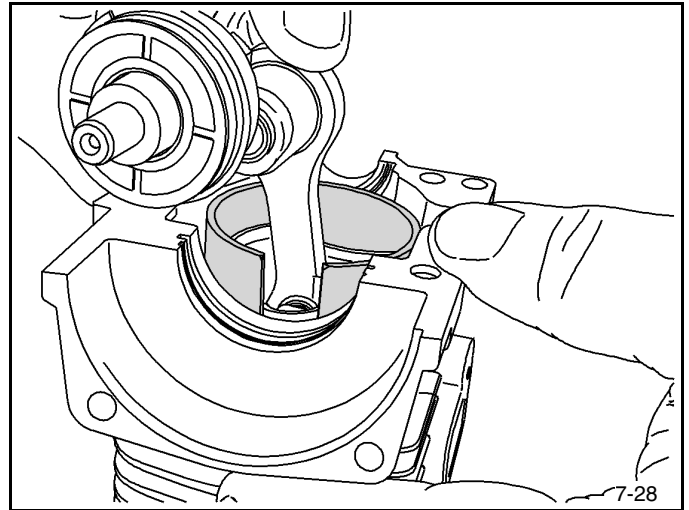

7. Clean both gasket surfaces using isopropyl alcohol before application of the gasket eliminator.
8. Apply Loctite #515 gasket sealant eliminator (Tecumseh part #510334) to the crankcase surface to seal the crankcase cover. Apply a continuous bead of Loctite (.062" [1.57 mm] bead width) on the crankcase surface according to the pattern. Loctite must not enter the crankcase (diag. 7-31).
9. Align the crankcase cover to the proper position using the mounting bolts as a guide. Once cover screws are snug, tap cover down using a soft mallet to help displace the gasket eliminator. Torque cover screws to recommended torque specifications. Tighten the bolts to achieve 105 inch pounds (11.8 Nm) of torque (diag. 7-32).
10. Install the compression release. Torque to 100 inch pounds (11.3 Nm).
11. Install the exhaust gasket, muffler, spark arrestor if applicable, and bolts. Torque the muffler bolts to 110 inch pounds (12.4 Nm).
12. Attach the blower housing base using three screws and torque the screws to 30-40 inch pounds (3.3 Nm - 4.5 Nm).
13. Attach and torque the air vane to the carburetor throttle shaft before installation.
14. On early TM engines, install the air baffle, gaskets, spacer, and carburetor. Assemble gaskets correctly, do not block the pulse passage. Torque the two hex nuts to 30-40 inch pounds (3.3 Nm - 4.5 Nm). (See Carburetor Assembly instructions on page 22, Chapter 3.)
15. On later TM engines, install long carburetor screws through the back of the spacer. Ensure that hex heads of the screw are properly seated in the spacer. Install the air baffle, gaskets and spacer on the engine. Install gaskets correctly, do not block the pulse passage. Torque the two hex screws to 30-40 inch pounds (3.3 Nm - 4.5 Nm).
16. Install the flywheel key and flywheel. Install the flywheel washer and nut, use a strapwrench (part #670305) to hold the flywheel, and torque the nut to 15-20 foot pounds (1.6 Nm - 2.2 Nm).

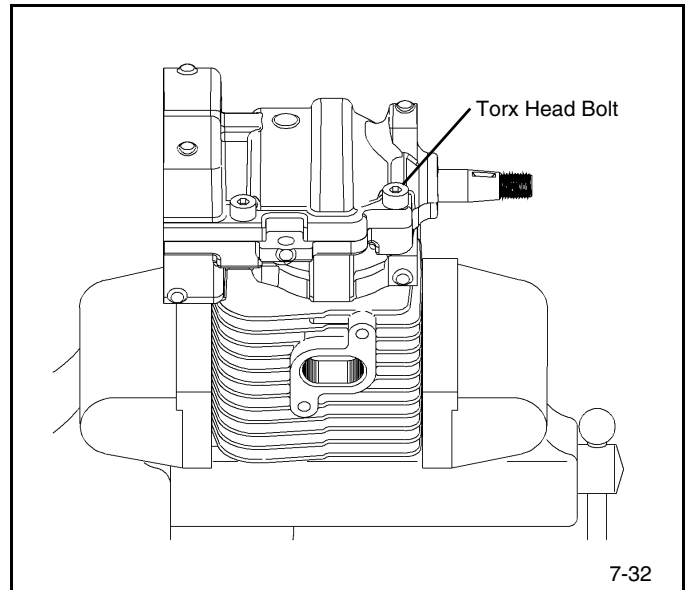
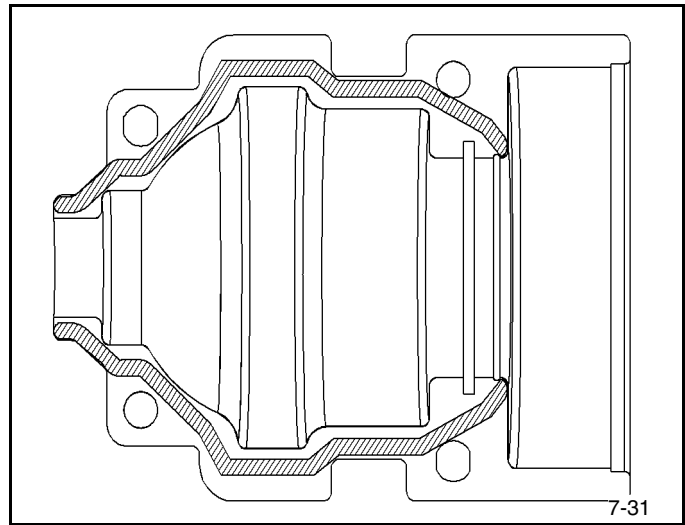

Go to next page.

17. Attach the ignition module, use the air gap gauge between the flywheel magnets and the module laminations (use .0125" [.317 mm] gauge part # 670297). Torque the module mounting screws to 30-40 inch pounds (3.3 Nm - 4.5 Nm). Remove the air gap gauge, rotate the flywheel to assure it does not strike the ignition module. Attach ignition grounding lead to the module terminal (diag. 7-33).
18. Install the blower housing and rewind assembly. Replace the debris guard if applicable. (diag. 7-33).
19. On later TM engines, install gasket and carburetor. Install sleeve spacers over carburetor screws. (diag. 7-34).
20. Hook the long end of the governor spring in the hole in the air vane and the short end in the hole in the speed control bracket. The spring hooks from beneath both components. Use the illustration (diag. 7-35) and the following spring location chart if the air vane has more than one governor spring hole and uses a colored spring with a square and round end.

SPRING COLOR	SPRING POSITION
Orange or Green	1
Pink, Red, or Black	2

21. Hook the upper fuel tank mounting tab over the blower housing stud and the carburetor studs. Make sure the "O" ring is in position between the fuel tank and the carburetor. Torque two hex nuts to 30-40 inch pounds (3.3 Nm - 4.5 Nm). (See Carburetor Assembly instructions on page 22, Chapter 3.) Install filter(s), and attach the air cleaner cover. Connect the fuel line at the tank, position the fuel line clamp on the fuel fitting

**NOTE**

*Make sure sleeve spacers are installed. If they are not installed, the retaining nuts may loosen.*

22. Reset the governor and/or speed control using the procedure in Chapter 4 under "Service".
23. Install the spark plug and connect the high tension lead.

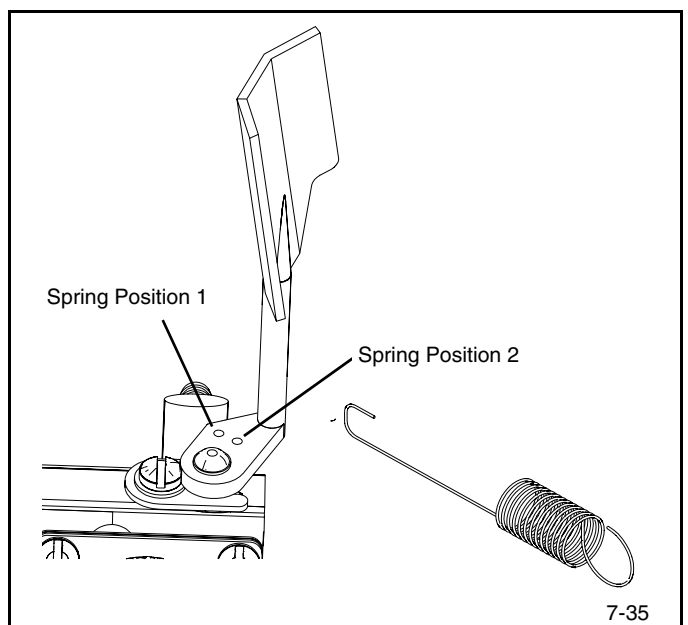
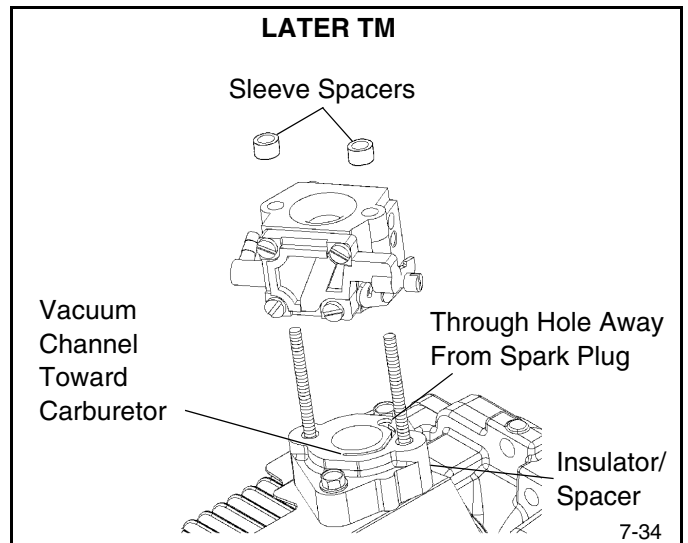
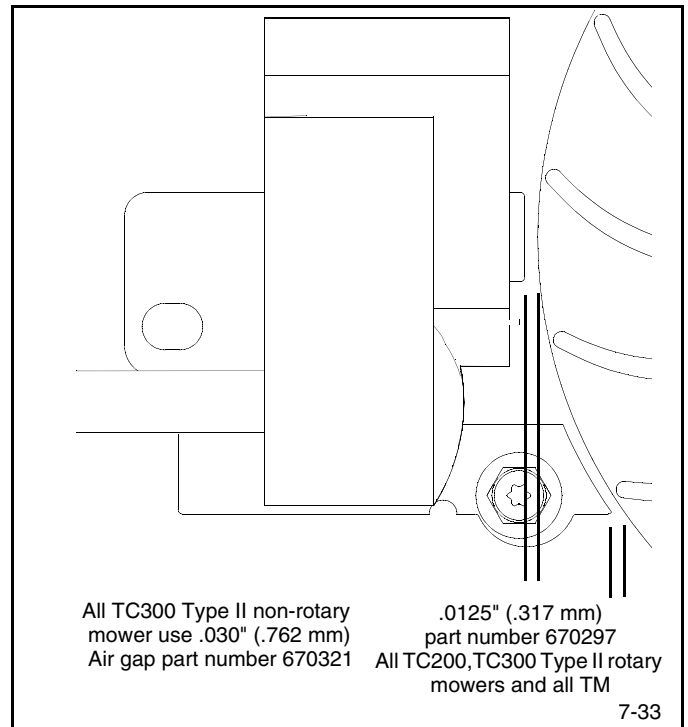

# CHAPTER 8

## ENGINE SPECIFICATIONS AND SEARS CRAFTSMAN CROSS-REFERENCE

### TORQUE SPECIFICATIONS

The torque specifications listed in this chart are to be used for replacing components after disassembly, not for checking an existing engine bolt torque. Checking a torque value on a new or used engine may be lower due to torque relaxation that occurs on all engines from thermal expansion and contraction. However, sufficient clamping force exists and a re-torque is not necessary.

	Inch Lbs.	Ft. Lbs.	Nm
Crankcase Cover to Crankcase— TC Type I/II	88.0	7.0	10.0
Cylinder Block to Crankcase— TC Type I/II	88.0	7.0	10.0
Crankcase Cover to Cylinder—TM	105.0	9.0	12.0
Spark Plug	230.0	19.0	26.0
Flywheel Nut—TC Type I/II	210.0	17.5	24.0
Flywheel Nut—TM	220.0	18.0	25.0
Starter Pawl to Flywheel	73.0	6.0	8.5
Solid State Mounting Bolts	35.0	3.0	4.0
Muffler to Cylinder—TC Type I/II	95.0	8.0	11.0
Muffler to Cylinder—TM	110.0	9.0	12.5
Muffler Heat Shield—TM	25.0	2.0	2.8
Blower Housing Base to Crankcase	35.0	3.0	4.0
Starter Retainer Screw	35.0	3.0	4.0
Speed Control to Base— TC Type II/TM	35.0	3.0	4.0
Air Vane to Carburetor	4.0	—	.5
Carburetor to Block Nut— TC Type II and some TM	35.0	3.0	4.0
Spacer To Cylinder—TM	30.0	2.5	3.5
Carb to Spacer—TM	35.0	3.0	4.0
Filter/Tank to Carburetor	23.0	2.0	2.6
Fuel Tank to Housing	23.0	2.0	2.6
A/C Cover—TC Type II/TM	4.0	—	.5
Compression Release—TM	100.0	8.5	11.0

# ENGINE SPECIFICATIONS

All Dimensions are in inches	TC200		TC300 Type II		TM	
	US	Metric mm	US	Metric mm	US	Metric mm
HP (Approx.)	1.6	1.19 Kw	2.0	1.49 Kw	2.0	1.49 Kw
Bore	1.4370 1.4380	36.49 36.52	1.7495 1.7505	44.43 44.46	1.7495 1.7505	44.43 44.46
Stroke	1.25	31.7	1.25	31.7	1.25	31.7
Displacement (in <sup>2</sup> ) (cc)	2.0	32.78 cc	3.0	49.17 cc	3.0	49.17 cc
Spark Plug Gap	.030	.762	.030	.762	.030	.762
Ignition Module Air Gap	.0125	.317	.030 Note (A)	.762	.0125	.317
Piston Ring End Gap	.004 .014	.101 .355	.005 .015	.127 .381	.005 .015	.127 .381
Piston Diameter	1.4330 1.4345	36.398 36.436	1.7450 1.7465	44.303 44.361	1.7450 1.7465	44.303 44.361
Piston Ring Groove Width Top/Bottom	.0485 .0495	1.231 1.257	.0485 .0495	1.2319 1.2573	.0485 .0495	1.2319 1.2573
Piston Ring Width	.046 .047	1.168 1.193	.046 .047	1.1684 1.1938	.046 .047	1.1684 1.1938
Crankpin Journal Diameter	.5985 .5990 Note (B)	15.201 15.214	.5985 .5990 Note (B)	15.201 15.214	N/A	N/A
Main Bearing Diameter P.T.O. Side	.6248 .6253 Note (C)	15.869 15.882	.6248 .6253 Note (C)	15.869 15.882	N/A	N/A
Main Bearing Diameter Flywheel	.4993 .5003	12.682 12.702	.4993 .5003	12.682 12.707	N/A	N/A
Crankshaft End Play	.004 .012 Note (D)	.1016 .305	.004 .012 Note (D)	.1016 .305	N/A	N/A

**Note (A)** - TC300 rotary mower applications use .0125" (.317 mm) air gap.

**Note (B)** - Mechanically retained needle bearings use .6850/.6855 (17.399 mm / 17.411 mm)  
or .6870/.6875 (17.449 mm / 17.462 mm)

**Note (C)** - Check to determine bearing diameters .7498/.7503 (19.044 mm / 19.057 mm),  
.6695/.6699 (17.005 mm / 17.015 mm), .5898/.5903 (14.980 mm / 14.993 mm)

**Note (D)** - Engine with P.T.O. ball bearings no end play.

## SEARS CRAFTSMAN CROSS REFERENCE

143.042070	TM049XA	3604A or 3604B
143.042072	TM049XA	3621B
143.681001	TC300	3010A
143.681021	TC300	3013A
143.941600	TC200	2103C
143.961670	TC200	2124D
143.961672	TC200	2103D
143.971670	TC200	2103E
143.971674	TC200	2124E
143.972070	TC300	3153E
143.982070	TC300	3176F
143.982072	TC300	3173F
143.992070	TC300	3187F
200.651001	TC200	2019C
200.681001	TC300	3010A
200.681021	TC300	3013A
200.681061	TC300	3021A
200.691001	TC300	3019A
200.691011	TC200	2040D
200.701011	TC200	2045E
200.701021	TC300	3027B
200.701031	TC300	3013B
200.701041	TCH300	3305
200.701051	TC300	3031B
200.711021	TCH300	3305A
200.711031	TC300	3013C
200.721001	TC200	2103
200.731031	TC300	3013E

# CHAPTER 9 EDUCATIONAL MATERIALS AND TOOLS

## TECHNICIAN'S HANDBOOKS

### 692508

Covers the diagnosis and repair of Tecumseh 2-cycle engines. Except the TC/TM Engine and 840-850.

### 692509

Covers the diagnosis and repair of the Tecumseh 4-cycle L-head engines.

### 691462A

Covers the diagnosis and repair of Tecumseh 4-cycle cast iron engines.

### 691218

Covers the diagnosis and repair of Peerless® power train components.

### 694782

Contains technical information for the repair of the TC/TM series, 2-cycle engines.

### 694988

Contains diagnosis and technical information for the repair of TVS840, HSK/HXL845/850, 2-cycle engines.

### 695244A

Covers the diagnosis and repair of the OHV 4-cycle overhead valve engines.

### 695578

Covers the diagnosis and repair of the Vector/VLV Series, 4-cycle engines.

### 696325

Covers the diagnosis and repair of the V-Twin engines.

## VIDEO PROGRAMS

### 69633 TVT, VTX, OV691EA

This video provides a complete teardown and reassembly guide for the OV691EA (TVT691) twin cylinder engine.

### 695148

Teardown and reassembly of the 900 series transaxles. This video will show a complete step-by-step procedure for teardown and reassembly of the 900, 910 and 920 series transaxles.

### 695285

An in-depth look at the 800 series transaxles. Detailing the teardown and reassembly procedures for the 800, 801 and 820 transaxles.

### 696250

An in depth look at the manual transaxle MST Series. This film will help you understand correct disassembly, repair and reassembly procedures.

## SPECIAL BOOKLETS

### INSTRUCTIONAL GUIDE

#### 692738

Assists in the use and understanding of the Tecumseh Master Parts Manual. Illustrates time saving features incorporated into the manual.

### 4-CYCLE ENGINE FAILURE ANALYSIS

#### 695590

This booklet is designed as a tool for the average technician to correctly assess the cause of failure.

### CARBURETOR IDENTIFICATION, TROUBLESHOOTING AND SERVICE BOOKLET

#### 695907

This booklet is designed as a quick reference to carburetion problems and related repair procedures.

### IGNITION SYSTEMS TROUBLESHOOTING BOOKLET

#### 694903

This booklet contains information on the identification, possible problems and related repair procedures of Tecumseh Ignition Systems.

### SERVICE TOOLS BOOKLET

#### 694862

This booklet depicts all specialty tools offered by Tecumseh which can be used on 2 and 4 cycle engines and Peerless units.

### QUICK REFERENCE CHART BOOKLET

#### 695933

This booklet contains the quick reference information found on Tecumseh wall charts.

This booklet is designed to be used as a work bench quick reference guide when servicing Tecumseh engines and motion drive systems.

## TOOLS

**FLYWHEEL PULLER**

**670299**

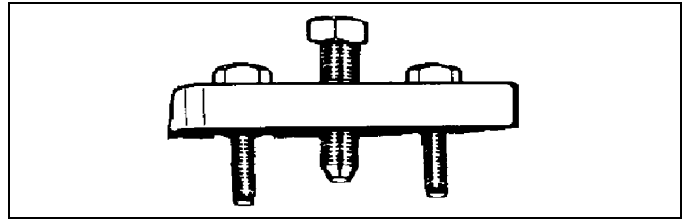

**STRAP WRENCH**

**670305**

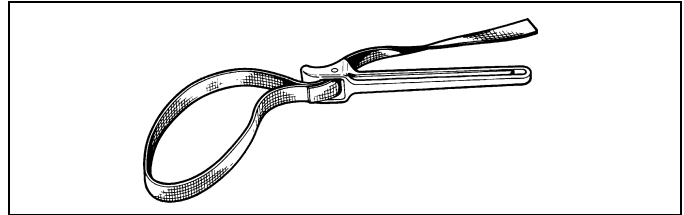

**HEAVY GAUGE WIRE HOOK FOR REMOVING MUFFLER SPRINGS**

1/4"  
(6.35 mm)

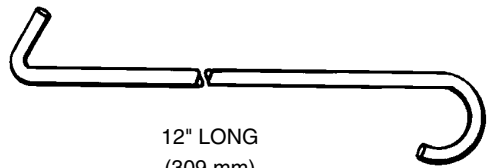

12" LONG  
(309 mm)

**PISTON AND ROD HOLDER**

A piece of 3/8" (9.5 mm) wood, 1-1/2" (38.1 mm) wide by 4" (101 mm) long with a slot 3/8" (9.5 mm) wide by 2" (50 mm) long cut out of the center will hold the piston and rod.

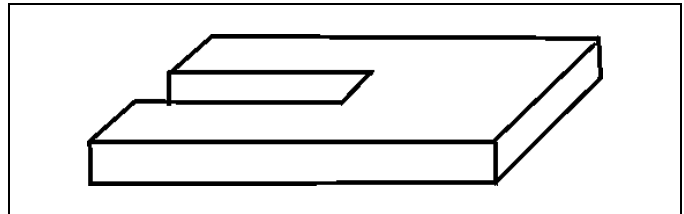

**SPARK TESTER**

**670366**

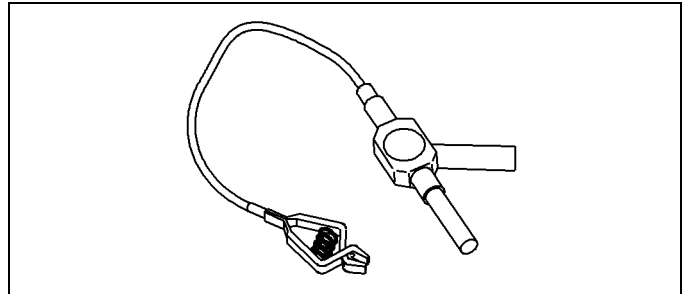

**RING COMPRESSOR**

**670391**

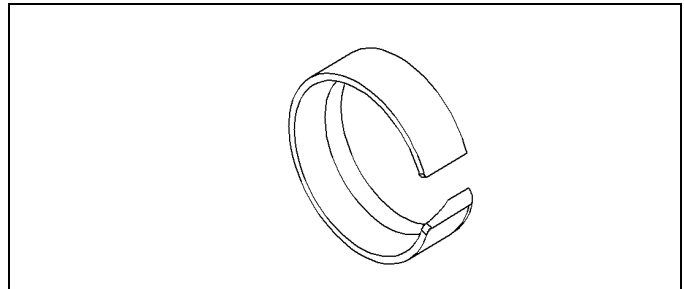



**ENGINE HOLDER****670300**

To assist in reassembly of the engine block and its components an Engine Holder, part # 670300, has been developed. Attach to the crankcase of the engine with the blower housing base screws and insert the other end into a bench vise to hold crankcase while inserting engine components. Use on TC200 Type I and TC300 Type II engines.

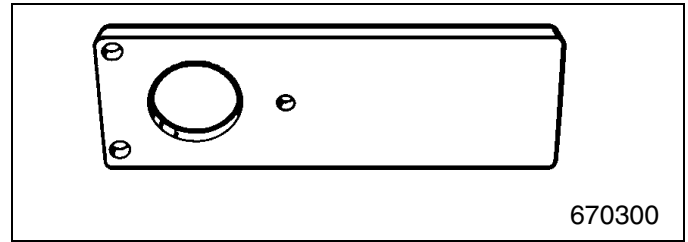

670300

**AIR GAP GAUGE****670297**

Used on all TC200 Type I, TC300 Type II rotary mower applications and all TM.

**AIR GAP GAUGE****670321**

Used on TC300 Type II non-rotary mower engine applications.

**SEAL PROTECTOR AND INSTALLER****670303**

Used on the PTO oil seal. TC Type I/II

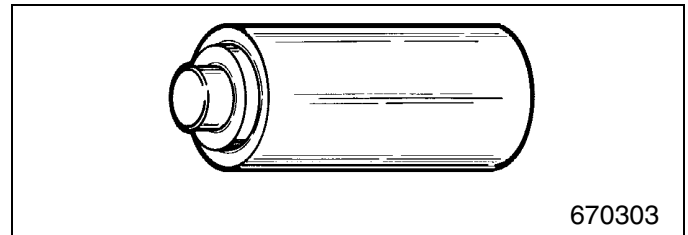

670303

**BEARING INSTALLER****670304A**

Used to install the PTO bearing. TC Type I/II

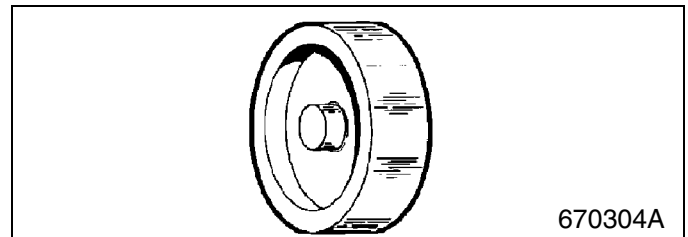

670304A

**SEAL PROTECTOR AND INSTALLER****670301**

Used on the flywheel end oil seal. TC Type I/II/TM

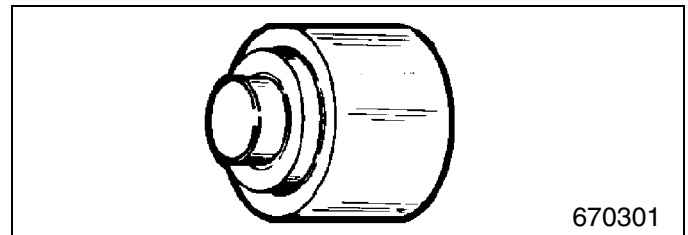

670301

**BEARING INSTALLER****670302**

Used to install the bearing in the flywheel end. TC Type I/II

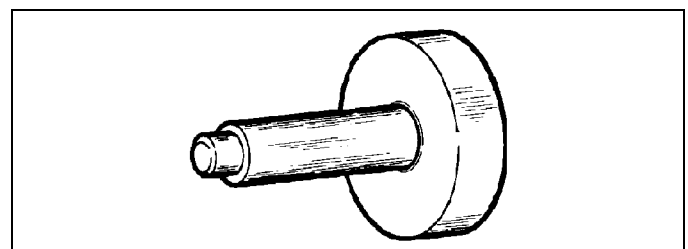

**SEAL PROTECTOR AND INSTALLER**

**670275**

Used on the PTO end oil seal. TC Type III

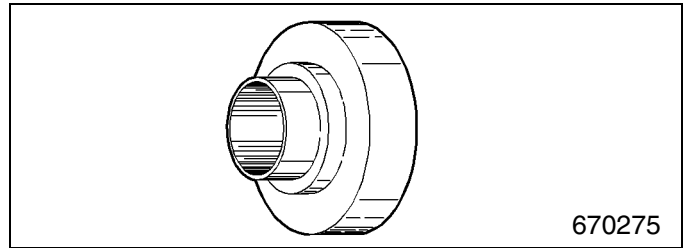

**TORX DRIVERS**

Torx 8	670334
Torx 10	670333
Torx 15	670323
Torx 20	670324
Torx 25	670319
Torx 30	670320

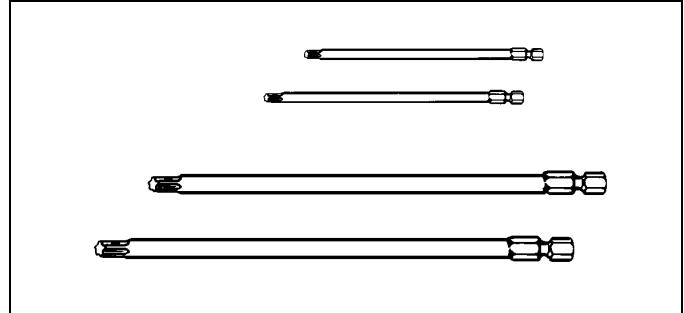

**SPECIAL PART**

**510334**

Loctite Gasket Sealant Eliminator No. 515 will be sold by Tecumseh under the part # 510334.

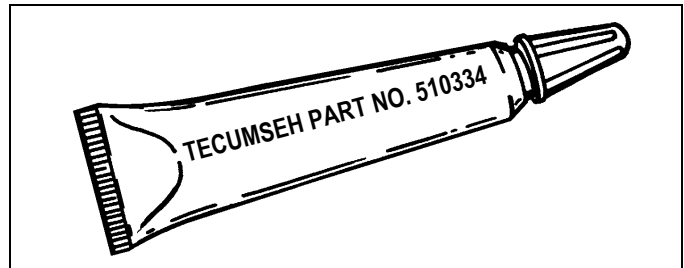

**VIBRATION TACHOMETER**

**670156**

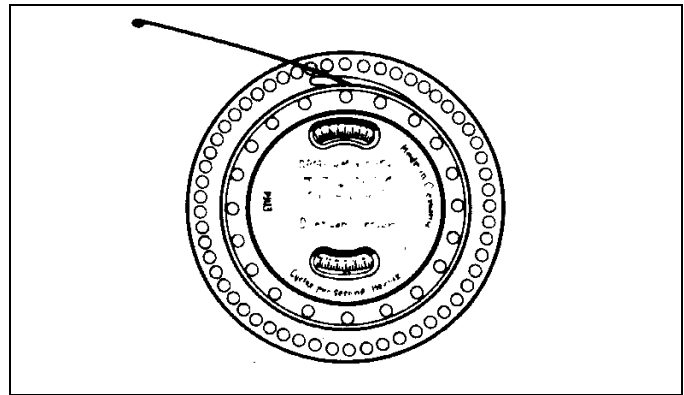

**METERING LEVER GAGE**

**670325**

Used to set carburetor metering lever.

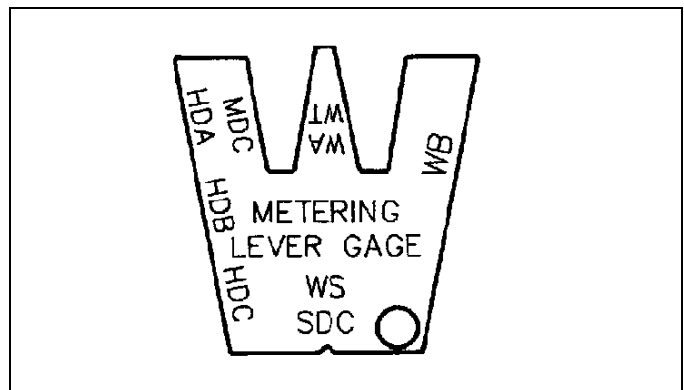

**This manual covers all TC and TM models.**

---

**Other illustrated Tecumseh 2-Cycle Engine, 4-Cycle Engine  
and Transmission Technician's Handbooks and wall charts  
are available through Tecumseh.**

**For complete listing write or call**

---



**ENGINES & TRANSMISSIONS**

**Tecumseh Power Company**  
900 North Street  
Grafton, WI 53024  
Phone: 262-377-2700  
Fax: 262-377-4485

**Tecumseh Europa S.p.A.**  
Strada delle Cacce, 99  
10135 Torino, Italy  
Tel. (39) 0 11 391-8411  
Telefax (39) 0 11 3910031

**740109**



[www.TecumsehPower.com](http://www.TecumsehPower.com)