

Language, Literacy & Vocabulary!



Windows on Literacy®

Teacher's Guide for Force and Motion Early Science

Includes:

- Lesson Plans
- Learning Masters
- Pre- and Post-Test Assessments
- Take-Home Book Masters

Copyright ©2008 The Hampton-Brown Company, Inc., a wholly owned subsidiary of The National Geographic Society, publishing under the imprints National Geographic School Publishing and Hampton-Brown.

All rights reserved. No part of this book may be reproduced or transmitted in any form or by any means, electronic or mechanical, including photocopying, recording, or by an information storage and retrieval system, without permission in writing from the Publisher.

National Geographic and the Yellow Border are registered trademarks of the National Geographic Society.

National Geographic School Publishing
Hampton-Brown
P.O. Box 223220
Carmel, California 93922
www.NGSP.com

Printed in the United States of America.

ISBN 978-07362-57237

08 09 10 11 12 13 14 15 16 17

10 9 8 7 6 5 4 3 2 1

Language, Literacy & Vocabulary!



Windows on Literacy®

Program Overview

About the Program	2
Accessible Academic Content . . .	4
Flexible Use	6

Force and Motion Lessons

Lesson Overview	8
Lesson 1	10
Lesson 2	12
Lesson 3	14
Lesson 4	16
Lesson 5	18

Learning Masters

What I Learned	22
How I Learned	23
Theme Song	24
Learning Masters	25
Family Focus	29

Pre- and Post-Test Assessments

Instructions	32
Answer Key	33
Student Profile	34
Class Profile	35
Pre-Test	36
Post-Test	38

Take-Home Book Masters

About the Program

Content and Literacy Development for Diverse Language Learners

National Geographic's *Windows on Literacy: Language, Literacy & Vocabulary* program is designed for today's classroom—diverse, challenging, and complex. Many children come to school without the basic background knowledge and oral language development needed for academic success. *Language, Literacy & Vocabulary* provides the extra support young learners need to experience success from the start.

National Geographic's *Language, Literacy & Vocabulary* program offers rich opportunities for beginning learners to build background knowledge, develop vocabulary and oral language, and learn grade-level content. Throughout the nation, teachers told us they needed materials that scaffolded the learning so that children from diverse language backgrounds, at-risk readers, and children with learning challenges would have opportunities to achieve their full potential. The *Language, Literacy & Vocabulary* program meets this need through:

- Thematic units built around essential key concepts in science, social studies, and math
- Academic vocabulary development
- Age-appropriate and engaging nonfiction texts
- Considerate text with strong picture-text match
- Scaffolded, multilevel instruction for students at different levels of language proficiency
- Springboards to related reading and writing
- Customized instruction for English language learners (ELLs)
- Research-based instructional strategies
- Rich and varied teacher support and tools

Consulting Author: Linda Hoyt



Linda Hoyt is an educational consultant who strives to help teachers and school districts implement best practices in literacy instruction. She has had a rich array of experiences in education, ranging from classroom teaching to working as a reading specialist, curriculum developer, Title 1 teacher, staff developer, and Title 1 District Coordinator. She is the author of numerous books, articles, and videos and conducts presentations and workshops on literacy throughout the country.

Program Advisor: Mary Hawley

Mary Hawley is an educational consultant who has worked with teachers, educators, and publishers to implement best practices for teaching students with diverse language backgrounds. She has taught English as a Second Language in Mexico, worked with migrant and refugee children in Indiana, and studied in Latin America. In recent years, she has been instrumental in developing Spanish reading programs and products for English language learners.

Program Reviewers

Susan Brandt, Director of Staff Development and Support Programs,
Arlington Heights School District 25, Arlington Heights, Illinois

Theresa Castelan, English Language Development Resource Teacher,
Clovis Unified School District, Clovis, California

Dr. Beverly Ann Chin, Professor of English, University of Montana

Danielle Clayton, Director of English Learners, Kings Canyon Unified
School District, Reedley, California

Paula Olson, retired teacher, Fairfax County Public Schools, Fairfax, Virginia

Sheryl Powell, Pre-Kindergarten Teacher, Wells Branch Elementary School,
Austin, Texas

Accessible Academic Content

Success From the Start!

Achieving academic success is essential for children to make adequate yearly progress and for continued academic growth. Conclusive data and research show that children who fall behind on their acquisition of academic content and vocabulary during the K–2 years will fall further behind as they advance through the grade levels. To help children achieve success from the start and prevent them from falling behind, *Windows on Literacy: Language, Literacy & Vocabulary* gives children access to the core grade-level content they need for standards-based academic success through these features:

- Explicit instruction in core academic content and vocabulary to build a foundation for future success
- Focused, targeted, standards-based content
- Alignment with TESOL standards
- Multiple exposures to and applications of academic vocabulary
- Carefully leveled developmental texts
- Picture glossaries of key content vocabulary
- Simple, engaging, and visually striking student book pages
- Strong picture-text match
- Familiar language and simple sentence structures
- Multiple opportunities for oral language development
- Theme Builders for building background and developing oral language
- Opportunities for writing and related reading

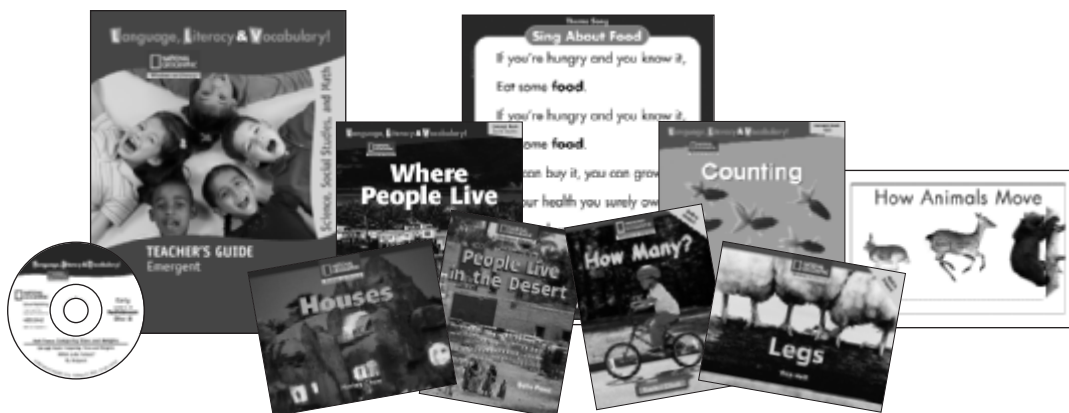

One Program for Your Diverse Classroom

Windows on Literacy: Language, Literacy & Vocabulary recognizes that every classroom includes diverse language learners as well as children whose background knowledge and oral language require development. Teachers told us they wanted one program that they could use with English language learners, children with reading and vocabulary challenges, and children with learning issues that affect their ability to acquire and process language. With appropriate modifications for different needs, *Language, Literacy & Vocabulary* gives teachers a sound, research-based instructional plan to meet the common needs among diverse language learners.

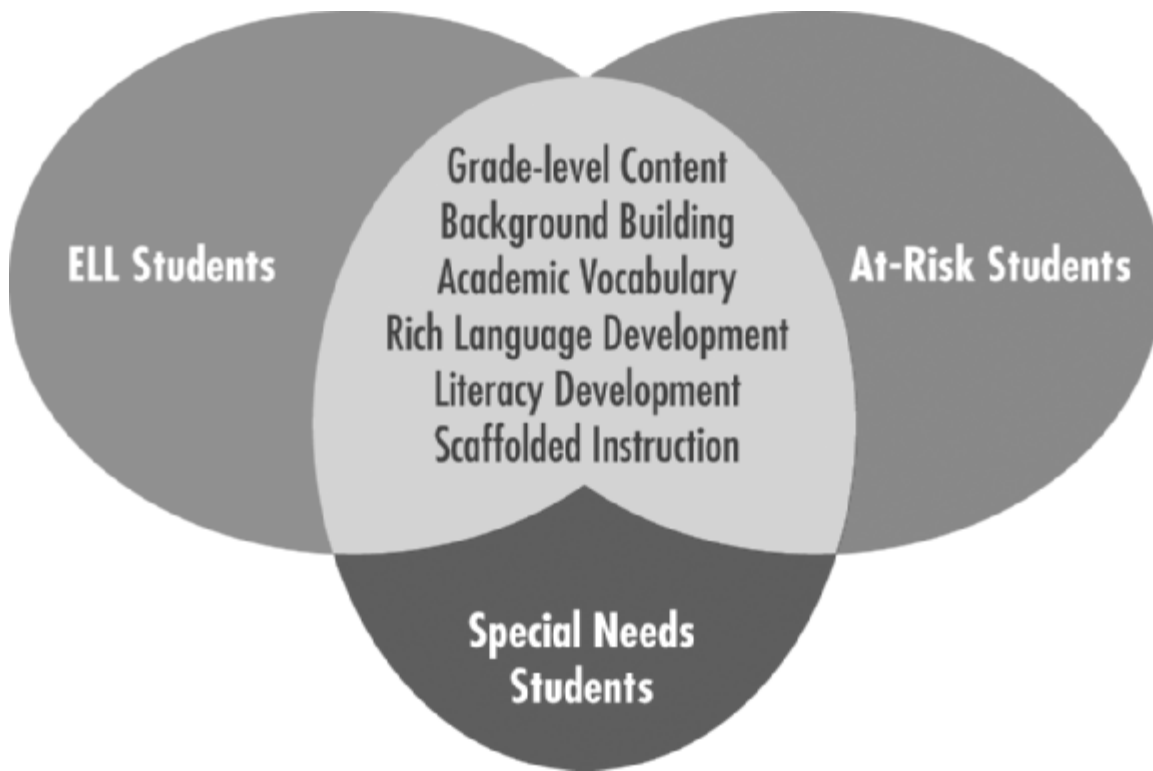

Flexible Use

Windows on Literacy: Language, Literacy & Vocabulary is designed to be used in a variety of classroom situations. This flexibility allows you to custom fit the program to match your scheduling and program needs.

Regular Classrooms

The chart below shows the suggested pacing for use in the regular classroom. Each theme can be completed in five days.

Pacing Guide: One Week for One Theme	
Day 1 • Lesson 1	Administer Pre-Test Read Concept Book Introduce Concepts and Vocabulary Model the Reading
Day 2 • Lesson 2	Reread Concept Book Develop Concepts and Vocabulary Introduce Comprehension Strategy Small Group Reading Modeled Writing
Day 3 • Lesson 3	Read First Related Nonfiction Book Develop Concepts and Vocabulary Small Group Reading Practice Comprehension Strategy Shared Writing
Day 4 • Lesson 4	Read Second Related Nonfiction Book Review Concepts and Vocabulary Small Group Reading Apply Comprehension Strategy Guided Writing
Day 5 • Lesson 5	Rereading and Assessment Guided Writing Optional Reading Home Connection Administer Post-Test

After-School Programs

Language, Literacy & Vocabulary works within a variety of after-school programs. Whether your after-school program meets every day or only three days a week, the program can easily be adjusted to meet your scheduling needs.

- For programs that meet every day, one theme can be completed each week of the program. Use the Pacing Guide on page 6.
- For programs that meet three times per week, one theme can be completed every two weeks. Use the suggested plan shown below.

Pacing Guide: Two Weeks for One Theme

Week 1 · Day 1 · Lesson 1	Week 2 · Day 1 · Lesson 4
Pre-Test Read Concept Book Introduce Concepts and Vocabulary Model the Reading	Read Second Related Nonfiction Book Review Concepts and Vocabulary Small Group Reading Apply Comprehension Strategy
Week 1 · Day 2 · Lesson 2	Week 2 · Day 2 · Begin Lesson 5
Reread Concept Book Develop Concepts and Vocabulary Introduce Comprehension Strategy Small Group Reading Modeled Writing	Assess and Extend Rereading and Assessment Begin Guided Writing
Week 1 · Day 3 · Lesson 3	Week 2 · Day 3 · Complete Lesson 5
Read First Related Nonfiction Book Develop Concepts and Vocabulary Small Group Reading Practice Comprehension Strategy Shared Writing	Complete Guided Writing Optional Reading Home Connection Post-Test

Summer School Programs

Language, Literacy & Vocabulary is the perfect fit for your summer school program. When time is short and results matter, your class time must be productive. The five-day lesson plan allows you to complete one theme during each week of your summer school program. Whether your summer school plan includes a four-, five-, or six-week program, you can select developmentally appropriate themes that focus on the content areas of math, science, and social studies while developing strong literacy skills.

Four-Week Program

Choose four themes.

Five-Week Program

Choose five themes.

Six-Week Program

Choose six themes.

Overview

Force and Motion

STANDARDS

ACADEMIC LANGUAGE /ELD

- Use academic vocabulary related to the study of force and motion
- Use appropriate language forms to discuss force and motion and to ask questions
- Develop fluency in reading, writing, listening to, and speaking English

SCIENCE

- Understand that force can make things move
- Classify different types of forces
- Understand that a magnet attracts some metal things

READING/LANGUAGE ARTS

- Learn and apply the comprehension strategy: Asking Questions
- Use the text features: Highlighted Words and Chart
- Write about force and motion
- Learn and use vocabulary related to force and motion

Before Theme Assessment

To compare progress before and after teaching this theme, use the Pre-Test and Post-Test Assessments, pages 32–39.

Theme Materials

Concept Book

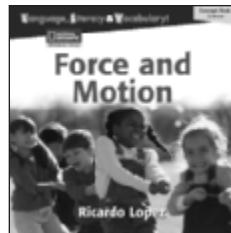

Nonfiction Books



Level 8



Level 8

Theme Builder



Learning Masters

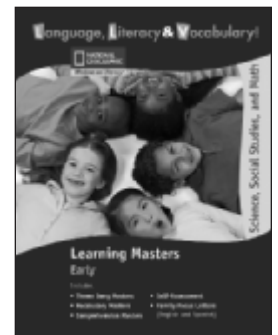

Audiolesson on CD



Take-Home Book Masters

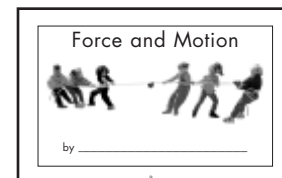

Optional Reading

Windows on Literacy Content-Based Fiction

The Fishing Game Level 7

Helping Toby's Team Level 8

Windows on Literacy Nonfiction

Press a Button Level 6

Wind Power Level 16

Machines Make Fun Rides
Level 16

Magnets Level 17

Instructional Highlights

Key Concepts

- A force is a push or a pull that makes an object move.
- A magnet can pull, or attract, some metal things.
- Different types of forces can be classified.

Comprehension Strategy

Asking Questions

Key Concept Words

attract move
force pull
magnet push
metal

Text Features

Highlighted Words
Chart

Theme Planner

Lesson 1*

Teacher's Guide
pp. 10–11

Read *Force and Motion*

- Administer Pre-Test, p. 36
- Introduce Concepts and Vocabulary
- Model the Reading

Lesson 2

Teacher's Guide
pp. 12–13

Reread *Force and Motion*

- Develop Concepts and Vocabulary
- Introduce the Comprehension Strategy: Asking Questions
- Small Group Reading
- Modeled Writing

Lesson 3

Teacher's Guide
pp. 14–15

Read *Push or Pull?*

- Develop Concepts and Vocabulary
- Small Group Reading
- Practice the Comprehension Strategy: Asking Questions
- Shared Writing

Lesson 4

Teacher's Guide
pp. 16–17

Read *My Magnet*

- Review Concepts and Vocabulary
- Small Group Reading
- Apply the Comprehension Strategy: Asking Questions
- Guided Writing

Lesson 5

Teacher's Guide
pp. 18–19

Assess and Extend

- Administer Post-Test, p. 38
- Rereading
- Guided Writing
- Assessment Tools
- Optional Reading
- Home Connection

Lesson 1

Read *Force and Motion*

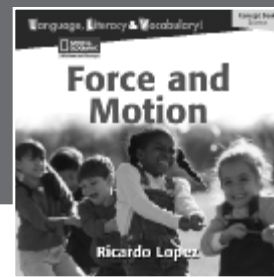

OBJECTIVES

- Understand that a force is a push or pull that makes an object move
- Learn and use vocabulary related to force and motion
- Use photos to predict vocabulary
- Use text features, such as highlighted words, to comprehend text

Materials

Realia: coin, book, plant, cup

Theme Builder

Force and Motion

Learning Masters page 24



Audiolesson 2

Theme Builder (Song)



Theme Builder (Scene)



Introduce Concepts and Vocabulary

Introduce Theme Question

Ask children: What is the difference between pushing and pulling? Explain that they will learn about different forces that can be used to move things and the language to use when talking about forces.

Have children draw pictures of one object that is moved by pushing and one object that is moved by pulling. Then put their pictures on a bulletin board. Explain that you push the pushpin to attach the picture and you pull the pushpin to remove the picture.

Develop Oral Language

Display a number of different-sized objects, such as a coin, a book, a plant, and a cup. Slowly push the cup along the surface and model the sentence: I can push the cup.

Next, slowly pull the cup toward you. Model the sentence: I can pull the cup.

Help children understand that both pushing and pulling are ways to make an object move. Invite learning partners to use the language forms for cause and effect as they take turns pushing and pulling the remaining objects.

What caused the (book) to move?

(Name) pushed it.

Tell children that in order to put the objects in motion, you used force.

Introduce the Theme Song

Display the Theme Song on the *Theme Builder* (tune: “There’s a Hole in the Bucket”). Sing the song

as you make pushing motions with your hands and body. Repeat, inviting children to sing and use pushing gestures along with you. Group children in pairs, and have them use *Learning Masters* page 24 to practice using the language of force and motion.

Introduce Key Vocabulary

Use the Think and Discuss scene to teach Key Concept Words and model language forms.

What causes the wagon to move?

The girl pulls the wagon.

What causes the clips to stick to the magnet?

The magnet attracts the clips.

Repeat with various classroom objects. As you introduce words, jot them down on chart paper. Display this Word Bank throughout the theme. Invite pairs of children to practice using the words and the language forms of cause and effect.

attract	magnet	move	push
force	metal	pull	

Build Background

Display the Think and Discuss scene on the *Theme Builder* again. Ask children what they notice. As children share observations, guide them to use the words *push* and *pull* to discuss forces. Then have children work together in pairs to talk about the scene and practice using the language forms for describing forces.

Model the Reading

Preview the Book

Distribute copies of *Force and Motion*. Read aloud the title and the author's name. As you page through the book, point out:

- The pages have labels or sentences.
- Some of the words on the pages are highlighted.
- All pages show objects being moved by forces.

Predict Vocabulary

Encourage children to use pictures to predict vocabulary: Which words do you expect to see in this book?

Display a page and cover the words: Which words do you expect to see on this page?

Children may mention the objects on the page—such as a shovel, a wagon, and a lawnmower. Point to the Word Bank and encourage children to use the words as they talk about the photos in the book.

Read Aloud

Invite children to follow along as you read *Force and Motion* aloud. As you read, pause to think aloud. Encourage children to ask questions and make observations.

Pages 6–7

Think Aloud I see that the word *push* is highlighted in the text, so I know that's an important word. When I look at the photos, I see that they all show things being pushed.

Pages 8–9

Think Aloud Now I see that the word *pull* is highlighted. I'm guessing that all the photos on this page will show things being pulled. I read the sentences and see that I'm right!

Pages 10–11

Think Aloud I see the word *magnet* is highlighted, so I think I'll be looking at magnets and reading about them. It's fun to see what a magnet attracts and what it doesn't.

Pages 14–15

Think Aloud I've seen a lot of things that can be pushed and pulled. I can use what I know about them to decide if the force that's needed to move the things on this page is pushing or pulling.

Page 16

Think Aloud This Picture Glossary helps me remember what each word means by showing me pictures to go along with each word.

Reread for Fluency

Have children reread the entire book independently to build fluency. See *Customize the Reading*.

Customize Instruction for ELLs

Newcomers/Beginning Have children respond to simple commands such as: "Push the book to a partner." "Pull the desk here."

Developing Move an object by either pushing or pulling it. Ask children to tell in complete sentences whether you pushed or pulled the object.

Expanding/Bridging Move an object by either pushing or pulling it. Ask children to use complete sentences to describe the object and how you moved it.

Name _____

Theme Song

There's a force that I'm using

To move things,

To move things.

There's a force that I'm using.

The force is a _____.



Song to the tune of
"There's a Hole in the Bucket."

push

pull

Customize the Reading

Children can read and talk about *Force and Motion* on their own to build fluency.

- Children who are not yet able to read the book can look at the photos and decide if the objects are being pushed or pulled.
- Children who need extra support can reread the book while listening to the audiobook.
- Children who can read the book might read independently or aloud with partners.

Lesson 2

Reread *Force and Motion*

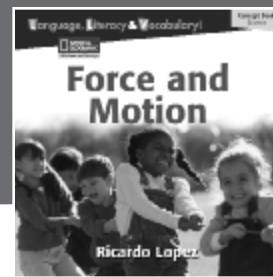

OBJECTIVES

- Understand that motion is caused by the force of pushing or pulling
- Use vocabulary to understand force and motion
- Learn the comprehension strategy: Asking Questions
- Write about an object that can be pushed or pulled

Materials

Realia: classroom objects

Theme Builder

Force and Motion

Learning Masters pages 25 and 26

Audiolesson 2

Theme Builder (Graphic Organizer)

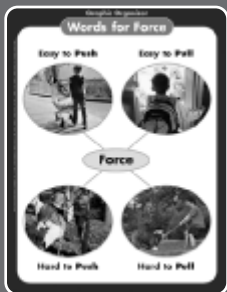

Develop Concepts and Vocabulary

Develop Oral Language

Ask children to name objects around the classroom that can be pushed or pulled. Then have children name objects that are attracted by a magnet. Encourage children to use these language forms:

I can push _____.

I can pull _____.

It's hard to push or pull _____.

A magnet attracts _____.

Revisit the Theme Song Display the song on the *Theme Builder*. This time, replace *push* with *pull* as you make a pulling motion with your hands and body. Invite children to use pulling gestures as they sing with you.

Build Background

Display the graphic organizer on the *Theme Builder*. Cover each picture, showing only the labels.

Point to a label and ask children to predict what the picture might be. Uncover the picture and have children use the object's name in a sentence using the language forms for cause and effect:

What causes the (*grocery cart*) to move?

The (*girl pushes*) it.

Repeat for the other labels.

Introduce the Comprehension Strategy

Introduce Asking Questions

When children ask questions, they generate questions as they read, look for answers that may or may not be in the text, and self-monitor their comprehension.

Think Aloud When I read a book, I often wonder about things I am reading and seeing in the pictures. That's called **asking questions**. I ask myself questions about what the words mean, what is happening in the book, and other things I want to learn. I look for answers to my questions in the text.

Model Asking Questions

Turn to pages 4–5 and model the comprehension strategy and language forms for asking questions.

Think Aloud Before I read, I wondered:

Do I understand the page? The label on page 5 says "wagon." When I look at the picture, I see that a small girl is pulling a big man in a wagon. How is this happening?

While I read, I wondered about the kind of force used. The text tells me that pushing and pulling are forces that make something move. The girl must be using a pulling force to move him.

After I read, I wondered: What else do I want to know? I wonder how hard it is for her to pull the wagon.

For additional practice in asking questions, have partners complete *Learning Masters* page 25.

Small Group Reading

As children read, invite them to share what they notice. Use some of the suggestions below to encourage observations and talk about the book.

Pages 4–5

Support Comprehension Remind children that when they read, they should ask themselves questions. Encourage them to use the language forms:

When I look at the pictures, I wonder _____.

When I read the labels, I ask myself _____.

After I read all of the text on the page, I ask _____.

Pages 6–9

Support Comprehension Have children look at the photos on these pages and read the text. Then ask them to tell how the photos on pages 6–7 and 8–9 are alike and different.

Pages 10–11

Support Comprehension Invite children to ask questions about magnets.

Check Understanding Does a magnet have a force? (*yes*) What kind of force does a magnet have? (*a pulling force*)

Pages 12–13

Support Comprehension Be sure children understand that the heavier an object is, the more force it needs to be moved. Have children look at the pictures and suggest other things that make an object hard to move.

Pages 14–15

Check Understanding Children can use this scene to apply what they have learned. Remind children to use the Word Bank to help them talk about how the objects are moved.

Discuss the Book

Invite children to use the words in the Word Bank to discuss what they have learned. Can they name two forces of motion? Can they name objects that are attracted by a magnet?

Children can complete *Learning Masters* page 26.

Reread for Fluency

Have children reread the entire book independently to build fluency. See *Customize the Reading*.

Modeled Writing

Display the graphic organizer on the *Theme Builder* with only one picture uncovered. Begin by modeling how to use different words to describe forces. Children can observe as you model the writing process. First, decide what to write.

Think Aloud The graphic organizer shows a girl and a shopping cart. I'll write a sentence about it. First, I'll decide what kind of force is used to move the cart: a push or a pull. I can use our Word Bank list if I need help with spelling.

The girl pushes a shopping cart to make it move.

Think Aloud I ask myself a question about moving this cart. I wonder if the cart is hard to move. The girl seems to be walking in an easy way, so I think she does not need to use too much force to push the cart. I'll write another sentence about what I just discovered.

The cart is not too hard to push.

I'll write more sentences about what I learned.

The wheels on the shopping cart help the girl. They make it easier to push the cart.

Learning Masters/page 25

Name _____

Asking Questions

Read pages 12–13 in *Force and Motion*. Then complete this page.

Before I read, I wondered

While I read, I wondered

After I read, I wondered

Customize the Reading

Children reread and talk about *Force and Motion*, using one of the following options:

- Look through the pages, naming the force that moves the object.
- Reread the book while following along with the audiolession.
- Read independently or read aloud with a partner.

Learning Masters/page 26

Name _____

Force and Motion

Use the words in the Word Bank to complete the sentences. Draw a picture that shows how force makes something move. Write a sentence for your picture.

Word Bank

1. Some objects need more _____ in order to move them.

push	pull
force	magnet
2. A _____ attracts some metal objects.
3. To move a wheelbarrow, you _____ it.
4. To open a drawer, you _____ it.

Lesson 3

Read *Push or Pull?*

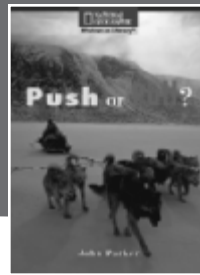

OBJECTIVES

- Read to gain fluency in oral and silent reading
- Practice the comprehension strategy: Asking Questions
- Understand that a force is a push or a pull that makes an object move
- Use highlighted words and other text features to comprehend text
- Notice organization to aid comprehension

Materials

Realia: classroom objects
Theme Builder
Push or Pull?
Learning Masters page 27
Audiolesson 2

Develop Concepts and Vocabulary

Develop Oral Language

Model the Key Concept Words *move*, *push*, and *pull* by asking a question. Model a question and answer:

Why does a bike move?

A child pushes the pedals.

In pairs, children can make up their own question and response, using the language you have modeled. Then ask volunteers to share their sentences.

Revisit the Theme Song Display the song on the *Theme Builder*. This time, sing both verses. Have children hold up an object that can

be pushed *or* pulled and make appropriate gestures as they sing.

Build Background

Distribute copies of *Push or Pull?* Invite children to name the object the person is traveling on and tell what they know about this way to travel.

Have partners draw pictures of objects from the book. Ask them to draw an arrow pointing away from the object if a pulling force is used to move it, and an arrow pointing toward the object if a pushing force is used to move it. Encourage partners to talk about their pictures.

Small Group Reading

Get Ready to Read

Preview the Book Read aloud the title, the author's name, and the Think and Discuss question on the back cover: Push or pull? Page through the book and do the following:

- Point out that each set of pages begins with a question and ends with an answer.
- Talk about the photos. Ask children what they know about each object.
- Ask children to predict what they will learn.

Predict Vocabulary Encourage children to use photos to predict vocabulary: Which words do you expect to see in this book?

Display a page and cover the words: Which words do you expect to see on this page?

List the words that children mention. Add Key Concept Words in the book that children do not mention.

Text Feature: Highlighted Words

Introduce Point out the highlighted word on page 3. Words are highlighted to call attention to them. When you see a highlighted word, it means that the word is important.

Model Read the sentence on page 3, emphasizing the word *pushes*. "The wind *pushes* the sailboat." The word is important because it answers the question on page 2. It also answers the question in the title.

Practice Have learning partners take turns reading the questions and emphasizing the highlighted word that helps give the answer.

Read the Book

As children read, invite them to share what they notice. Use some of the suggestions below to encourage observations and talk about the book.

Pages 2–3

Key Concept Words *move, push*

Support Comprehension Make sure children understand that the wind blows into the sails, which pushes the boat forward.

Check Understanding What would happen to the boat if there was no wind? (*The boat might not move.*)

Pages 4–7

Key Concept Word *pull*

Support Comprehension Count aloud with children the number of dogs that are pulling the sled. Make sure children understand that all of the dogs create enough force to move the sled, its driver, and the equipment on the sled. For page 7, ask: What makes the waterwheel move? Does the waterwheel need a lot of or a little force in order to move?

Pages 8–11

Practice the Comprehension Strategy

Encourage children to **Ask Questions** to help them understand these pages.

I saw a front-end loader near my house. It made a lot of noise. I wonder why that is.

Lead children to understand that the noise is the engine, which causes the machine to work.

Page 16

Support Comprehension Have children discuss how the pictures are arranged. Ask: How does this arrangement help you understand the book?

Discuss the Book

Invite children to use words in the Word Bank to discuss what they have learned. What did they learn about pushing and pulling? What things do they push and pull at home?

Use *Learning Masters* page 27.

Reread for Fluency

Have children reread the entire book independently to build fluency. See *Customize the Reading*.

Shared Writing

Have children name objects that can be moved. As a group, choose an object. Have children suggest words and sentences that help answer the question: “How can this object be moved?” Then model writing with input from the children.

You might model how to:

- Refer to the Word Bank for words and spellings.
- Use correct punctuation when asking a question and when giving an answer.

Customize Instruction for ELLs

Newcomers/Beginning Give children examples of objects that can be pushed and/or pulled. Have children say *push*, *pull*, or *push and pull*.

Developing Have children make a two-column chart and list objects that can be pushed and objects that can be pulled.

Expanding/Bridging Have children suggest other questions they have about how objects can be moved.

Name _____
Push or Pull?

Look at each picture.
Which force moves the object—a push or a pull?
Write **push** or **pull** under the picture.

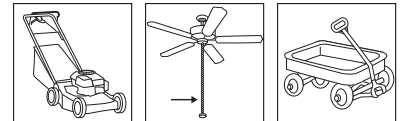
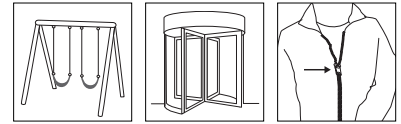

Customize the Reading

Children can reread and talk about *Push or Pull?* using one of the following options:

- Look through the pages, pointing to and naming objects that can only be pushed.
- Reread the book while following along with the audiolesson.
- Read independently or aloud with a partner.

Lesson 4

Read My Magnet



OBJECTIVES

- Read to gain fluency in oral and silent reading
- Apply the comprehension strategy: Asking Questions
- Understand that a magnet can pull, or attract, some metal things
- Use a chart and other text features to comprehend text
- Make and confirm predictions during reading

Materials

Realia: magnets of different shapes, small metal and nonmetal objects

Theme Builder

My Magnet

Learning Masters page 28

Take-Home Book Masters:
Force and Motion



Audiolesson 2

Review Concepts and Vocabulary

Develop Oral Language

Model the Key Concept Words *magnet* and *attract*. For example, hold a paper clip to a magnet. This magnet can attract a paper clip.

Then pick up a piece of paper and hold it to the magnet. This magnet cannot attract a piece of paper.

Ask pairs of children to try attracting metal and nonmetal objects with magnets. Encourage them to say sentences aloud that use these language forms:

This magnet can attract _____.

This magnet cannot attract _____.

Revisit the Theme Song Display the song on the *Theme Builder*. This time, replace *push* with *pull*. As children sing, invite them to point to items that are attracted to magnets.

Build Background

Distribute copies of *My Magnet* and talk together about the cover. Point out that the girl has used a magnet to attract paper clips. Ask children to share times when they played with a magnet and to tell what was attracted to the magnet. What was the most surprising thing that the magnet attracted?

Small Group Reading

Get Ready to Read

Preview the Book Read aloud the title, the author's name, and the Think and Discuss question on the back cover: What kinds of things does a magnet attract?

Page through the book and invite children to share what they notice.

- Point out the chart with pictures, used to answer a question.
- Discuss the objects in the photos and ask children to tell what they know about each object.
- Ask children to predict what they will learn.

Predict Vocabulary Encourage children to use photos to predict vocabulary: Which words do you expect to see in this book?

Display a page and cover the words: Which words do you expect to see on this page?

List words that children mention. Add Key Concept Words in the book that children do not mention.

Text Features: Chart

Introduce Point to the chart on page 16. This is a chart. It gives us information to help answer the question above it. This chart has two columns. The pictures in one column are of objects that a magnet attracts. The pictures in the other column are of objects that a magnet does not attract.

Model Point to the paper clip. I know that a paper clip *is* attracted by the magnet because it's in the column named "The magnet attracts these things."

Practice Name some of the objects on the chart and ask children if they are attracted or are not attracted to the magnet and how they know this.

Read the Book

As children read, invite them to share what they notice. Use some of the suggestions below to encourage observations and talk about the book.

Pages 2–3

Key Concept Words *magnet, attract*

Support Comprehension Point to the magnet on page 2. Ask children to predict what the girl will do with it.

Pages 4–6

Support Comprehension Point out that the girl is now curious about other objects that the magnet will attract.

Check Understanding Do you think the magnet will attract the dinosaur? (*no*) Why or why not? (*It is not made of metal.*)

Pages 7–8

Support Comprehension Have children study the object on page 7 and make a prediction about whether the magnet will attract the object or not. Then have them look at page 8 to confirm their prediction.

Pages 9–13

Support Comprehension Have children predict whether or not the magnet will attract each object. Encourage children to explain their predictions before confirming them.

Pages 14–16

Apply the Comprehension Strategy

Have children **Ask Questions** about what they are reading using these language forms:

Before I read, I wondered _____.

While I read, I wondered _____.

After I read, I wondered _____.

Discuss the Book

Invite children to use the words in the Word Bank to discuss what they have learned. Were their predictions about the objects that would be attracted by the magnet correct? What objects do magnets attract?

Use *Learning Masters* page 28.

Reread for Fluency

Have children reread the entire book independently to build fluency. See *Customize the Reading*.

Name _____

My Magnet

Cut out each picture.
Place each picture in the correct column of the chart.

Magnet Attracts	Magnet Does Not Attract

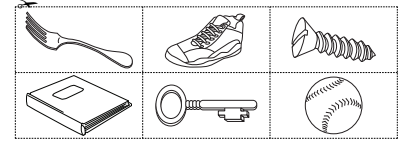

Guided Writing

Distribute copies of the *Take-Home Book Masters*. Read the title and page through the book. Explain that the children are the authors. They will write books about the forces that make objects move.

Work with children to:

- Read the Contents and the page headings.
- Name the pictured objects and tell if they are moved by pushing or pulling.

- Share writing ideas for each set of pages.

Record children's writing ideas for the pages of their books on chart paper. For example, children may want to suggest other objects that can be moved by pushing and pulling. Then have children begin writing. Display the Word Bank for spelling reference. Provide additional support as needed.

Customize the Reading

Children reread and talk about *My Magnet* using one of the following options:

- Look through the pages, naming other objects in the girl's room that the magnet might attract.
- Reread the book while following along with the audiolesson.
- Read independently or aloud with a partner.

Force and Motion



by _____

OBJECTIVES

- Use Key Concepts and Key Concept Words in writing
- Demonstrate oral language proficiency
- Demonstrate comprehension of theme selections
- Read related titles to reinforce Key Concepts and vocabulary

Materials

Take-Home Book Masters:
Force and Motion

Learning Masters pages 22–23, 29–30

Take-Home Book Masters**Force and Motion**

by

Rereading and Assessments

Allow time for children to independently reread the theme selections. Display the Word Bank for children's reference as they read.

As children reread, meet with individuals. Use the Post-Test on pages 38–39 to evaluate children's progress and to update their records.

Guided Writing

Children continue writing the Take-Home Books they began in Lesson 4. Review the group list of writing ideas. Also display the Word Bank.

Page through the theme books to review the text features, including highlighted words and charts. Talk about text features that children could add to their Take-Home Books. For instance, they might add their own chart showing things that move by pushing and by pulling.

Point out that good writers:

- Think about word choice. Remind children that *push* and *pull* are opposites.
- Check their words carefully. Remind children to use the Word Bank if they have spelling questions.

- Use the correct punctuation. Remind children that a question ends with a question mark and a statement ends with a period.

Have children review the Contents for labels to use to complete the Picture Glossary. For help with writing About the Author, ask children such questions as:

- What kinds of toys do you have that move? How do they move?
- What's the biggest magnet you've ever seen?
- What is something you think would be hard to move?

As children write, circulate to coach and support individuals. Then have partners share their finished books. Challenge them to identify text features and facts in each other's books.

Customize Instruction for ELLs

Newcomers/Beginning Have children dictate sentences and labels for the pictures they draw.

Developing Provide sentence frames for children, such as: What causes the _____ to move? The _____ (pushes/pulls) it.

Expanding/Bridging Have children write their own questions and answers, or complete sentences on their own. They can add labels or captions as necessary.

Assessment Tools

Self-Assessment

Allow children to reflect and assess their own learning by completing *Learning Masters* pages 22–23.

- What I Learned, page 22
- How I Learned, page 23

Reading

In addition to the Pre-Test and Post-Test Assessments, the following assessment tools, available online, can help you evaluate and record children's progress in reading.

- Retelling Guide and Scoring Rubric
- Fluency Scoring Guide
- Oral Reading Record

Writing

Use the completed Take-Home Books available online and the following tools to assess children's development as writers.

- Writing Rubric
- Developmental Checklist,

Content Assessment

Provide children with several photos of plants at different stages. Ask children to put the photos in the order that shows how plants grow and change. Invite them to describe each photo using the words and language forms they have learned.

Vocabulary and Oral Language

Use the following resources, available online, in addition to the Think and Discuss scene on the *Theme Builder*, to assess oral language development.

- Content Vocabulary Checklist
- Oral Language Developmental Checklist

Optional Reading

Reading related titles allows children to explore concepts and vocabulary at different levels. It also allows them to use reading strategies in different types of texts. Encourage children to compare the theme books to the books listed in the next column.

Optional Titles

These related *Windows on Literacy* titles reinforce Key Concepts of the *Force and Motion* theme.

Nonfiction Titles

Press a Button Level 6

Wind Power Level 16

Machines Make Fun Rides
Level 16

Magnets Level 17

Fiction Titles

The Fishing Game Level 7

Helping Toby's Team Level 8

Home Connection

The Family Focus letters on *Learning Masters* pages 29–30 summarize key concepts about force and motion. In the Share and

Learn activity, family members test objects at home to see if they move by pulling or pushing.

Learning Masters/pages 22–23

Name _____

What I Learned

What important things did you learn in this theme?

I learned that

I learned that

I learned that

Related Fiction Titles

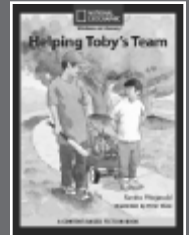

Learning Masters/pages 29–30

Name _____

Family Focus

Dear Family,
Your child has been reading the books *Force and Motion, Push or Pull?*, and *My Magnet* in our unit of study on forces that make things move. Please use this page to talk with your child about the different ways that force causes movement.

Words to Know

- attract
- move
- force
- pull
- magnet
- push
- metal

Your child has written a take-home book. Invite your child to read the book to you. Use these questions to discuss the book together:

- What forces are described in the book?
- Can any of the objects in the book be both pushed and pulled?
- What kind of material does a magnet attract?
- What does weight have to do with force?

Key Concepts

Your child has been learning these important ideas:

- A force is a push or a pull that makes an object move.
- A magnet can pull, or attract, some metal things.
- Different types of forces can be classified.

Share and Learn

Walk around your home with your child. Look for objects that move by pulling or pushing. Write their names in the appropriate column of the chart below. You might ask: Does this object require a lot of force or a little force to make it move?

Things That Move by Pushing Things That Move by Pulling

Things That Move by Pushing	Things That Move by Pulling

Language, Literacy & Vocabulary!



Windows on Literacy®

Learning Masters Early: Force and Motion

Name _____

What I Learned

What important things did you learn in this theme?

I learned that

I learned that

I learned that

How I Learned

Good readers do these things when they read.
Draw an X by the things you did when you read this text.

- I made connections.
- I thought about what would happen next.
- I asked questions before I read.
- I asked questions while I read.
- I made pictures in my mind.
- I picked out the most important ideas.
- I figured things out without the author telling me.

Give advice to another reader.

Name _____

Theme Song

There's a force that I'm using

To move things,

To move things.

There's a force that I'm using.

The force is a _____.



push

pull

*Sing to the tune of
"There's a Hole in the Bucket."*

Name _____

Asking Questions

Read pages 12–13 in *Force and Motion*.
Then complete this page.

Before I read, I wondered

While I read, I wondered

After I read, I wondered

Force and Motion

Use the words in the Word Bank to complete the sentences.
Draw a picture that shows how force makes something move.
Write a sentence for your picture.

Word Bank

push	pull
force	magnet

1. Some objects need more _____
in order to move them.

2. A _____ attracts some metal objects.

3. To move a wheelbarrow, you _____ it.

4. To open a drawer, you _____ it.

Name _____

Push or Pull?

Look at each picture.

Which force moves the object—a push or a pull?

Write **push** or **pull** under the picture.

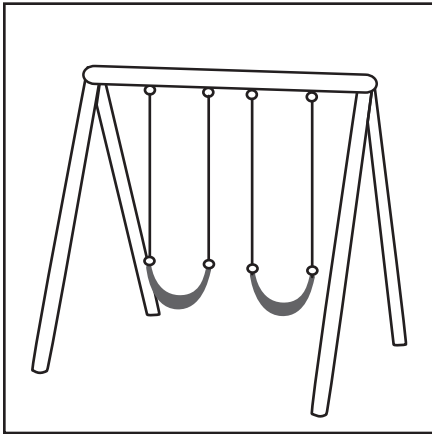

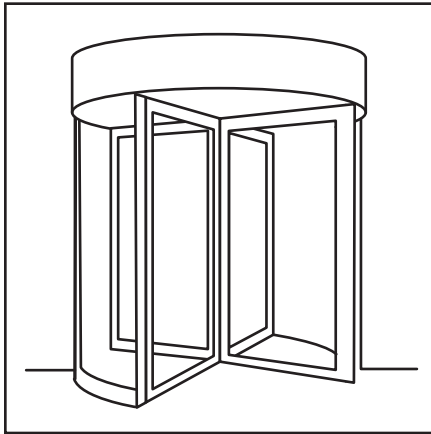

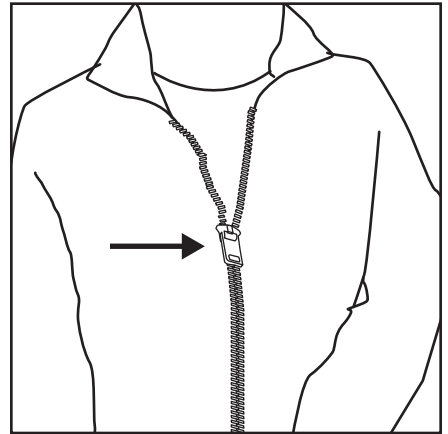

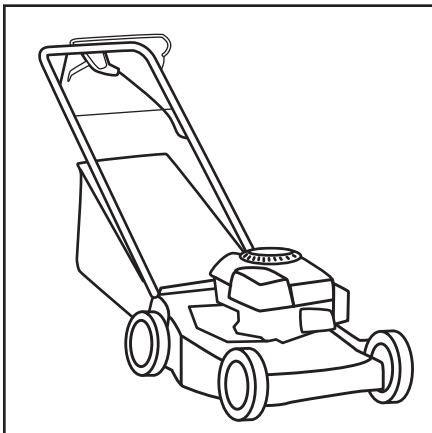

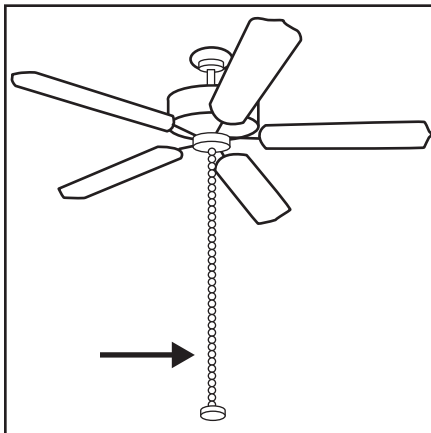

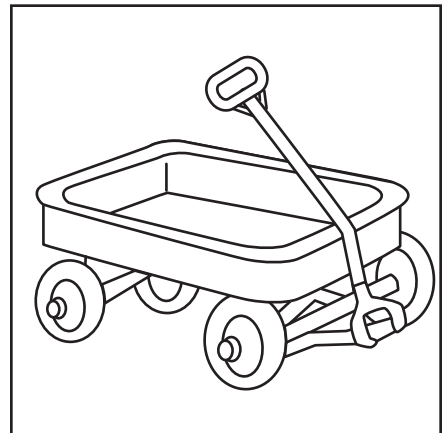

Name _____

My Magnet

Cut out each picture.

Place each picture in the correct column of the chart.

Magnet Attracts	Magnet Does Not Attract

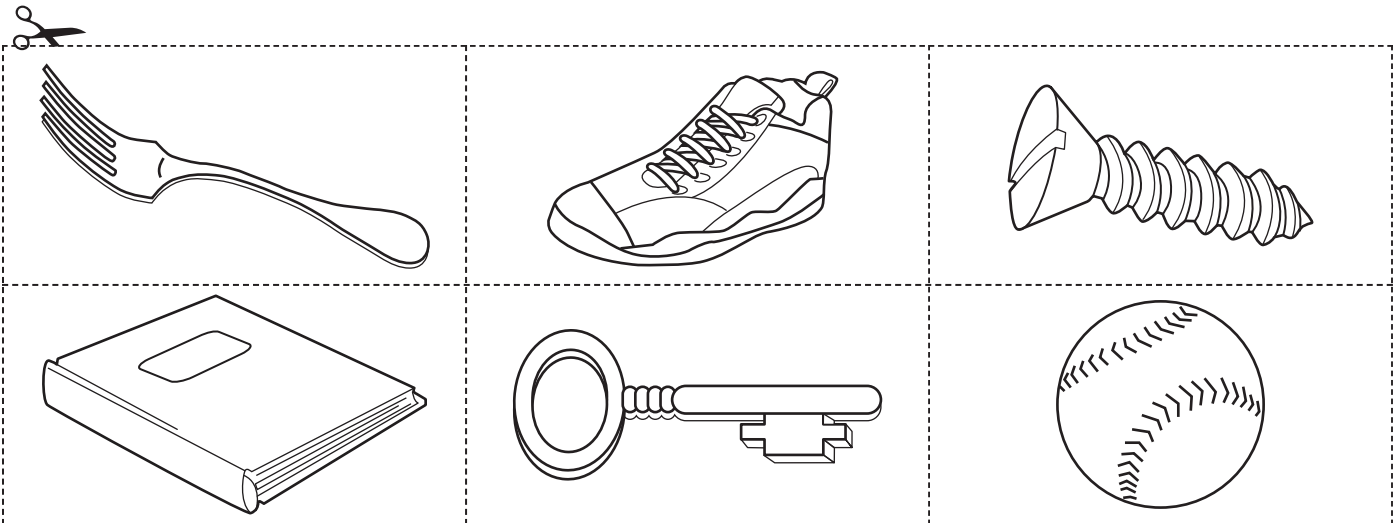

Family Focus

Dear Family,

Your child has been reading the books *Force and Motion, Push or Pull?*, and *My Magnet* in our unit of study on forces that make things move. Please use this page to talk with your child about the different ways that force causes movement.

Words to Know

• attract	• move
• force	• pull
• magnet	• push
• metal	

Your child has written a take-home book. Invite your child to read the book to you. Use these questions to discuss the book together:

- What forces are described in the book?
- Can any of the objects in the book be both pushed and pulled?
- What kind of material does a magnet attract?
- What does weight have to do with force?

Key Concepts

Your child has been learning these important ideas:

- A force is a push or a pull that makes an object move.
- A magnet can pull, or attract, some metal things.
- Different types of forces can be classified.

Share and Learn

Walk around your home with your child. Look for objects that move by pulling or pushing. Write their names in the appropriate column of the chart below. You might ask: *Does this object require a lot of force or a little force to make it move?*

Things That Move by Pushing	Things That Move by Pulling

Enfoque en la familia

Estimada familia,

Su escolar ha estado leyendo los libros *Force and Motion (La fuerza y el movimiento)*, *Push or Pull? (Empujar o jalar?)* y *My Magnet (Mi imán)* en nuestra unidad de estudio sobre las fuerzas que desplazan las cosas. Favor de usar esta página para hablar con su escolar sobre las maneras diferentes en que la fuerza causa el movimiento.

Su escolar ha escrito un libro para llevar a la casa. Pídale a su escolar que le lea el libro. Use estas preguntas para discutir el libro juntos.

- ¿Cuáles son las fuerzas descritas en el libro?
- ¿Es posible empujar y jalar algunos de los objetos en el libro?
- ¿Qué clase de material atrae un imán?
- ¿Qué tiene que ver el peso con la fuerza?

Vocabulario

<ul style="list-style-type: none"> • atraer (attract) • desplazar (move) • empujar (push) • fuerza (force) 	<ul style="list-style-type: none"> • imán (magnet) • jalar (pull) • metal (metal)
--	--

Ideas clave

Su escolar ha estado aprendiendo estas ideas importantes:

- Una fuerza es un empujón o jalón que desplaza un objeto.
- Un imán puede jalar, o atraer, algunas cosas hechas de metal.
- Se pueden clasificar los tipos distintos de fuerzas.

Compartir y aprender

Camine por su casa con su escolar. Busquen objetos que se desplazan al empujar o al jalar. Escriban sus nombres en la columna apropiada de la tabla abajo. Puede preguntarle: *¿Tienes que usar poca fuerza o mucha fuerza para desplazar el objeto?*

Cosas que se desplazan al empujar	Cosas que se desplazan al jalar

Language, Literacy & Vocabulary!



Windows on Literacy®

Assessments

Early: Force and Motion

Administering the Tests

About the Pre-Test and Post-Test

The Pre-Test and Post-Test measure students' performance in four skill domains:

- Concept Words
- Key Concepts
- Comprehension Strategies
- Text Features

The Pre-Test gives information about each student's baseline proficiency with the theme of study. Analyzing student results will help you select appropriate teaching strategies and target areas of need. The Post-Test, when compared with the Pre-Test data, captures students' gains and serves as a useful tool in documenting student progress.

Administering the Test

- 1 Before distributing the test, be sure that students have their Concept and Related Nonfiction books accessible. These texts are often referred to in both the Pre- and Post-Tests.
- 2 Distribute the test.
- 3 Look to make sure that each student is working on the correct page. Read all directions and test items out loud to students. Have students work individually on sections and allow a reasonable amount of time for them to complete each item.
- 4 Collect all tests and score them using the Answer Key on page 33.

Answer Key

Scoring the Pre-Test and Post-Test

Each item is worth one point. There are ten points total. Open-ended answers such as a drawing need to show an understanding of the key word or concept to receive the point. Do not penalize students for incorrect spelling or grammar.

Pre-Test

Concept Words (1–4)	Key Concepts (5 & 6)	Comprehension Strategy (7 & 8)	Text Features (9 & 10)
<i>1 point each</i>	<i>1 point each</i>	<i>1 point each</i>	<i>1 point each</i>
1. (d)	5. (a)	7. Answers will vary.	9. sailboat and waterwheel
2. (c)	6. (b)	8. Answers will vary.	10. sled and train
3. (a)			
4. (b)			

Post-Test

Concept Words (1–4)	Key Concepts (5 & 6)	Comprehension Strategy (7 & 8)	Text Features (9 & 10)
<i>1 point each</i>	<i>1 point each</i>	<i>1 point each</i>	<i>1 point each</i>
1. (d)	5. (a)	7. Answers will vary.	9. Answers will vary.
2. (b)	6. (b)	8. Answers will vary.	10. Answers will vary.
3. (a)			
4. (c)			

Student Profile for Pre-Test and Post-Test

Name _____

Test & Date	Concept Words	Key Concepts	Compr. Strategy	Text Features	Point Score	Percent Score
Pre-Test						
Date: _____	/4	/2	/2	/2	/10	%
Post-Test						
Date: _____	/4	/2	/2	/2	/10	%

Pre-Test

Name _____ Date _____

Concept Words

Listen to the words. Draw a line to the correct picture.

1. push

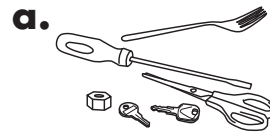

2. magnet



3. metal

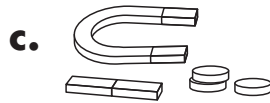

4. pull



Key Concepts

Circle the correct picture.

5. attract

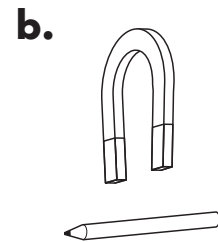

6. force



Pre-Test

Name _____ Date _____

Comprehension Strategy

Read pages 10–11 in *Force and Motion*.
Write down two more things you want to learn about magnets.

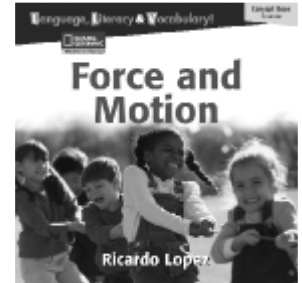

7. I want to know _____

8. I want to know _____

Text Features

Below you see an empty **push and pull** chart. Draw lines from each picture to the correct side of the chart. The first one is done for you.

9. Push	10. Pull

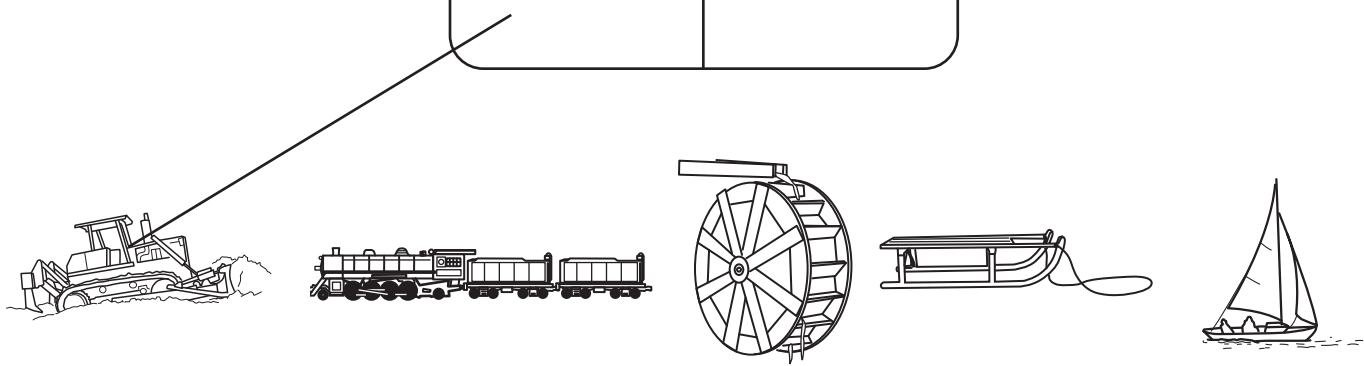

Post-Test

Name _____ Date _____

Concept Words

Listen to the words. Draw a line to the correct picture.

1. push



2. pull



3. attract

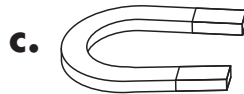

4. magnet



Key Concepts

Circle the correct picture.

5. This shows "move."

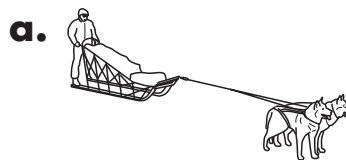

6. This shows "push."



Post-Test

Name _____ Date _____

Comprehension Strategy

Read pages 8–9 in *Force and Motion*.
What does this make you think about?

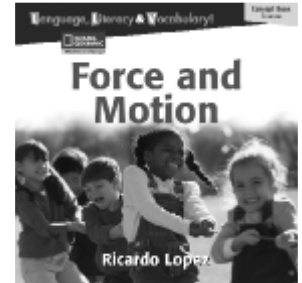

7. I wonder _____

8. This I wonder _____

Text Features

Below, draw something new that a magnet attracts. Then draw something new that a magnet does not attract.

9. Magnet Attracts	10. Magnet Does Not Attract

Language, Literacy & Vocabulary!



Windows on Literacy®

Take-Home Book Masters Early: Force and Motion

Force and Motion



by



Contents

Push	4
Pull	6
How Much Force?	8
Magnets	10
Picture Glossary	12

About the Author

2



Push



4

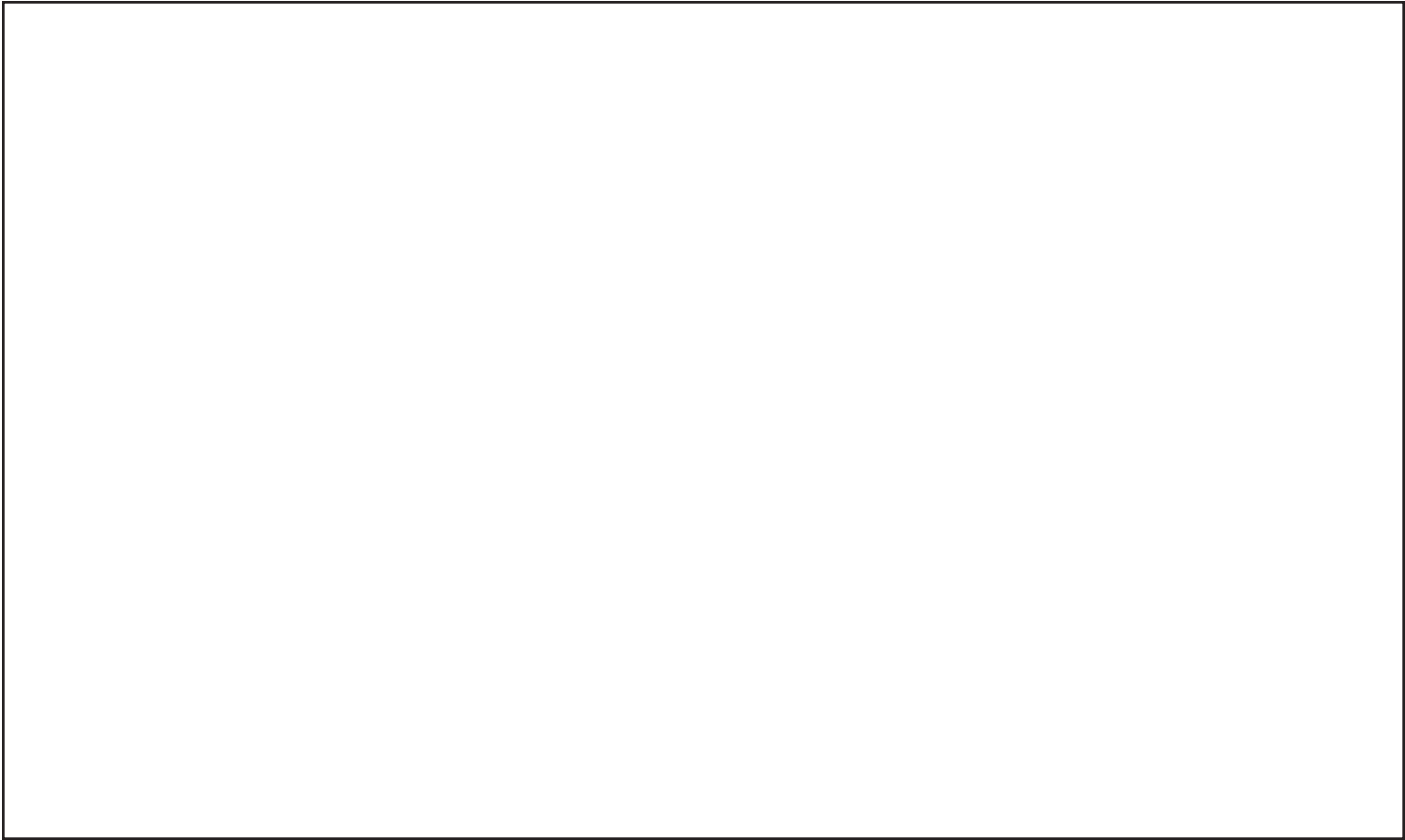

5

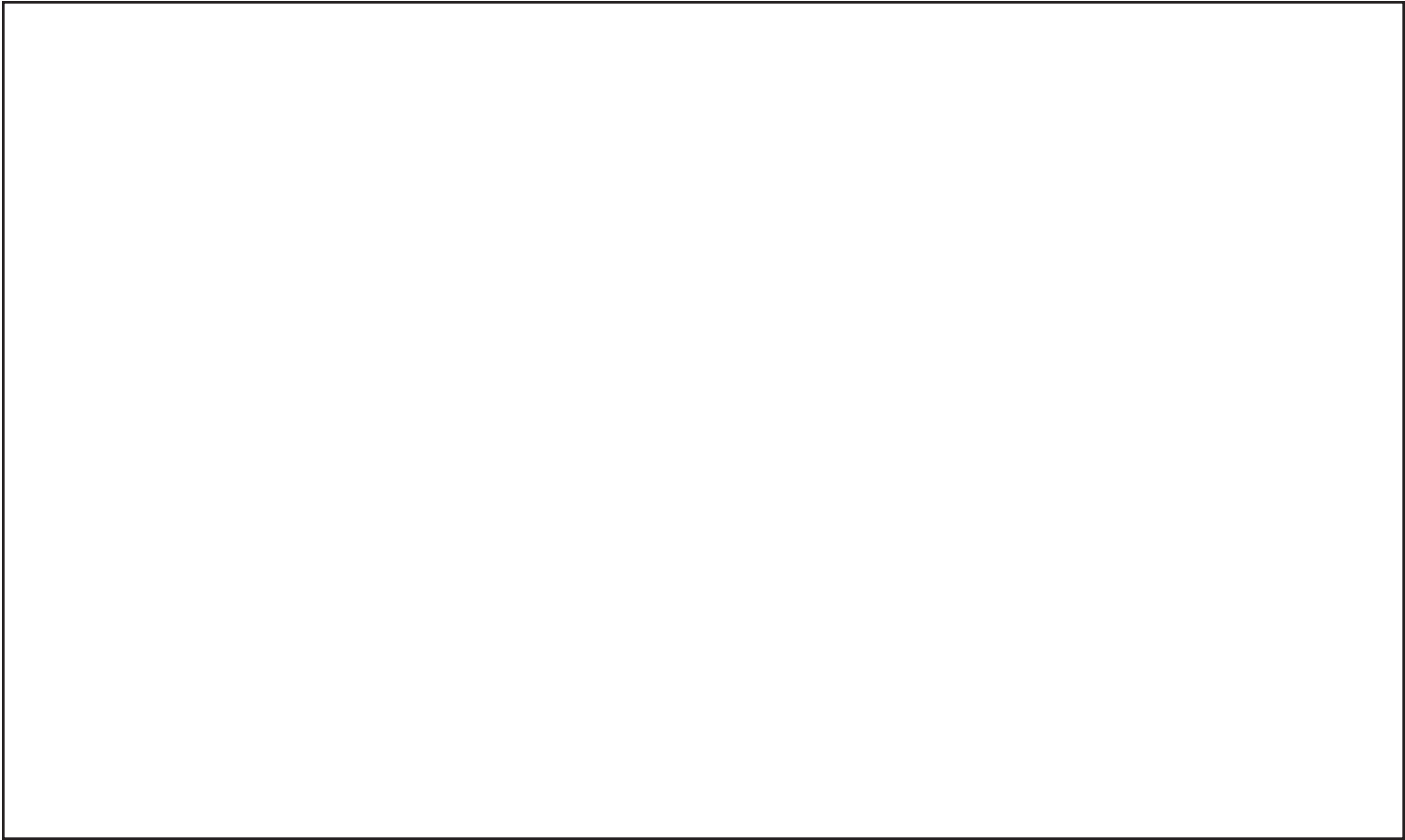

7

Pull



6



How Much Force?

Less Force



More Force



8

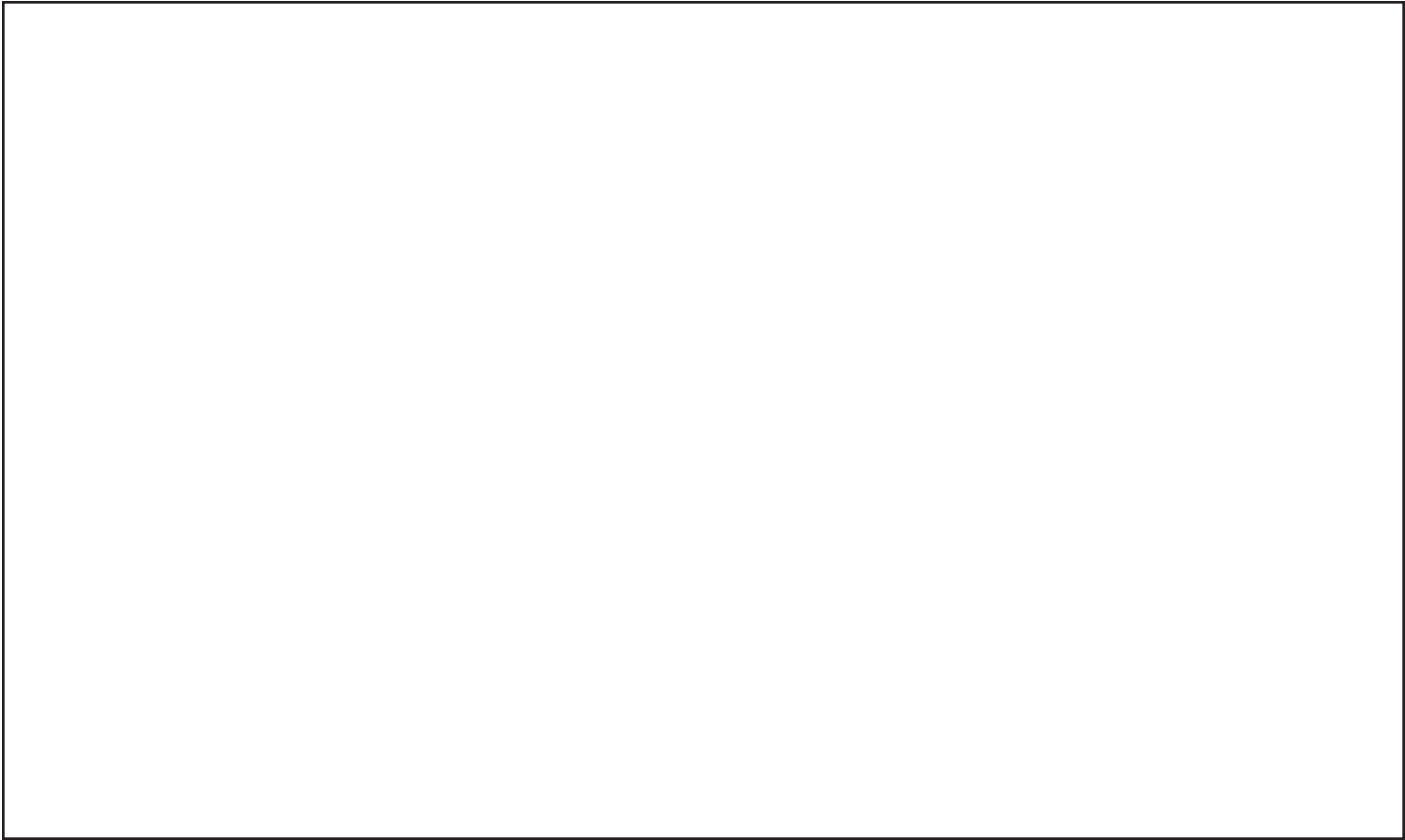

9



11

Magnets

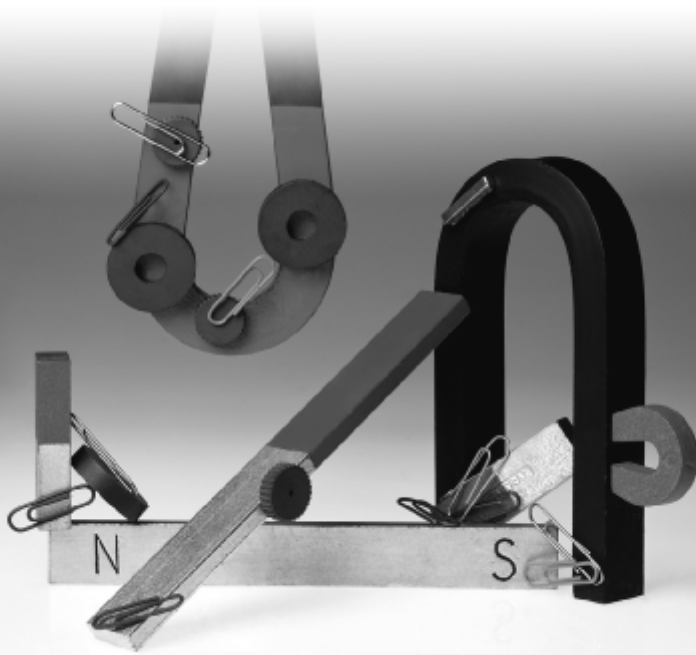

10



Picture Glossary



12

Early Themes

