

# Teaching Mathematics with Manipulatives



# Mathematics

Applications and Concepts

Course 2



New York, New York   Columbus, Ohio   Chicago, Illinois   Peoria, Illinois   Woodland Hills, California

## Manipulatives

Glencoe offers three types of kits to enhance the use of manipulatives in your Middle School Mathematics classroom.

- The **Glencoe Mathematics Overhead Manipulative Resources** contains translucent manipulatives designed for use with an overhead projector.
- The **Glencoe Mathematics Classroom Manipulative Kit** contains classroom sets of frequently used manipulatives in algebra, geometry, measurement, probability, and statistics.
- The **Glencoe Mathematics Student Manipulative Kit** contains an individual set of manipulatives often used in Student Edition activities.

The manipulatives contained in each of these kits are listed on page vi of this booklet.

Each of these kits can be ordered from Glencoe by calling (800) 334-7344.

Glencoe Mathematics Overhead Manipulative Kit	0-07-830593-4
Glencoe Mathematics Classroom Manipulative Kit	0-02-833116-8
Glencoe Mathematics Student Manipulative Kit	0-02-833654-2



The McGraw-Hill Companies

Copyright © by The McGraw-Hill Companies, Inc. All rights reserved. Permission is granted to reproduce the material contained herein on the condition that such materials be reproduced only for classroom use; be provided to students, teachers, and families without charge; and be used solely in conjunction with the *Glencoe Mathematics: Applications and Concepts, Course 2*, program. Any other reproduction, for sale or other use, is expressly prohibited.

Send all inquiries to:  
Glencoe/McGraw-Hill  
8787 Orion Place  
Columbus, OH 43240-4027

ISBN: 0-07-860125-8

*Teaching Mathematics with Manipulatives*

Printed in the United States of America.

1 2 3 4 5 6 7 8 9 10 045 11 10 09 08 07 06 05 04 03

# Contents

<b>Easy-to-Make Manipulatives</b>	<b>Page</b>		
Base-Ten Models . . . . .	1	2-6 Using Overhead Manipulatives: Quartiles . . . . .	39
Decimal Models . . . . .	2	2-8 Using Overhead Manipulatives: How Much is a Handful? . . . . .	41
Fraction Models: Bars . . . . .	3	<b>CHAPTER 3</b>	
Fraction Models: Circles . . . . .	4	Teaching Notes and Overview . . . . .	42
Counters . . . . .	5	3-3 Mini Project: Coordinate Plane Puzzle . . . . .	44
Integer Counters . . . . .	6	3-4a Hands-On Lab Recording Sheet . . . . .	45
Pattern for Cup . . . . .	7	3-5a Hands-On Lab Recording Sheet . . . . .	46
Integer Mat . . . . .	8	3-6 Using Overhead Manipulatives: Multiplying Integers . . . . .	47
Equation Mat . . . . .	9	<b>CHAPTER 4</b>	
Quarter-Inch Grid . . . . .	10	Teaching Notes and Overview . . . . .	49
Centimeter Grid . . . . .	11	4-2a Hands-On Lab Recording Sheet . . . . .	51
Square Dot Paper . . . . .	12	4-3 Mini-Project: Solving Multiplication Equations . . . . .	52
Isometric Dot Paper . . . . .	13	4-4 Using Overhead Manipulatives: Solving Two-Step Equations . . . . .	53
Tangram . . . . .	14	4-6a Hands-On Lab Recording Sheet . . . . .	55
Number Lines . . . . .	15	4-6 Using Overhead Manipulatives: A Function of Time . . . . .	56
First Quadrant Grids . . . . .	16	<b>CHAPTER 5</b>	
Coordinate Planes . . . . .	17	Teaching Notes and Overview . . . . .	58
Percent Models . . . . .	18	5-1a Hands-On Lab Recording Sheet . . . . .	59
Spinners . . . . .	19	5-5 Using Overhead Manipulatives: Percent . . . . .	60
Number Cube Patterns . . . . .	20	<b>CHAPTER 6</b>	
Protractors . . . . .	21	Teaching Notes and Overview . . . . .	61
Rectangular Prism Pattern . . . . .	22	6-4 Using Overhead Manipulatives: Multiplying Fractions and Mixed Numbers . . . . .	62
Cube Pattern . . . . .	23	6-8 Mini-Project: Perimeter . . . . .	64
Cylinder Pattern . . . . .	24	6-9a Hands-On Lab Recording Sheet . . . . .	65
Cone Pattern . . . . .	25	<b>CHAPTER 7</b>	
Pyramid Pattern . . . . .	26	Teaching Notes and Overview . . . . .	66
Pattern Blocks . . . . .	27	7-1 Using Overhead Manipulatives: Equal Ratios . . . . .	68
Circle Graph Template . . . . .	28	7-2b Hands-On Lab Recording Sheet . . . . .	70
Problem-Solving Guide . . . . .	29	7-3b Hands-On Lab Recording Sheet . . . . .	71
		7-4 Mini-Project: Scale Drawings . . . . .	72
		7-8a Hands-On Lab Recording Sheet . . . . .	73
<b>Activities</b>	<b>Page</b>		
<b>CHAPTER 1</b>			
Teaching Notes and Overview . . . . .	30		
1-2 Mini-Project: Modeling Powers and Exponents . . . . .	31		
1-4 Using Overhead Manipulatives: Variables and Expressions . . . . .	32		
1-7b Hands-On Lab Recording Sheet . . . . .	34		
<b>CHAPTER 2</b>			
Teaching Notes and Overview . . . . .	35		
2-2 Mini-Project: Story Graph . . . . .	37		
2-4b Hands-On Lab Recording Sheet . . . . .	38		

**CHAPTER 8**

	Teaching Notes and Overview . . . . .	74
<b>8-1</b>	Mini-Project: Percent and Estimation . . . . .	75
<b>8-3a</b>	Hands-On Lab Recording Sheet . . . . .	76
<b>8-4</b>	Using Overhead Manipulatives: Percent of Change . . . . .	77

**CHAPTER 9**

	Teaching Notes and Overview . . . . .	79
<b>9-4</b>	Using Overhead Manipulatives: Exploring Permutations . . . . .	81
<b>9-5a</b>	Hands-On Lab Recording Sheet . . . . .	83
<b>9-6</b>	Mini-Project: Theoretical and Experimental Probability . . . . .	84
<b>9-6b</b>	Hands-On Lab Recording Sheet . . . . .	85

**CHAPTER 10**

	Teaching Notes and Overview . . . . .	86
<b>10-1a</b>	Hands-On Lab Recording Sheet . . . . .	90
<b>10-1b</b>	Hands-On Lab Recording Sheet . . . . .	91
<b>10-2</b>	Using Overhead Manipulatives: Jelly Bean Statistics . . . . .	92
<b>10-3b</b>	Hands-On Lab Recording Sheet . . . . .	93
<b>10-4b</b>	Hands-On Lab Recording Sheet . . . . .	94
<b>10-5</b>	Using Overhead Manipulatives: Investigating Triangles and Quadrilaterals . . . . .	95
<b>10-7</b>	Mini-Project: Quadrilateral Tessellations . . . . .	97

<b>10-7</b>	Using Overhead Manipulatives: Angles of a Polygon . . . . .	98
<b>10-7</b>	Using Overhead Manipulatives: Inscribed Polygons . . . . .	100
<b>10-8b</b>	Using Overhead Manipulatives: Dilations . . . . .	102
<b>10-9b</b>	Hands-On Lab Recording Sheet . . . . .	104

**CHAPTER 11**

	Teaching Notes and Overview . . . . .	105
<b>11-3a</b>	Hands-On Lab Recording Sheet . . . . .	107
<b>11-4</b>	Using Overhead Manipulatives: Area . . . . .	108
<b>11-5a</b>	Hands-On Lab Recording Sheet . . . . .	110
<b>11-6</b>	Mini-Project: Areas of Circles, Rectangles, and Squares . . . . .	111
<b>11-8</b>	Using Overhead Manipulatives: Probability and Area Models . . . . .	112

**CHAPTER 12**

	Teaching Notes and Overview . . . . .	114
<b>12-1a</b>	Hands-On Lab Recording Sheet . . . . .	116
<b>12-2</b>	Using Overhead Manipulatives: Volume of Pyramids . . . . .	117
<b>12-3</b>	Mini-Project: Volume of Solids . . . . .	119
<b>12-4a</b>	Hands-On Lab Recording Sheet . . . . .	120
<b>12-4b</b>	Hands-On Lab Recording Sheet . . . . .	121

## Teacher's Guide to Using *Teaching Mathematics with Manipulatives*

**T**he book contains two sections of masters— Easy-to-Make Manipulatives and activities for Middle School Mathematics. Tabs help you locate the activities for each chapter. A complete list of manipulatives available in each of the three types of Glencoe Mathematics Manipulative Kits appears on the next page.

### **Easy-to-Make Manipulatives**

The first section of this book contains masters for making your own manipulatives. To make more durable manipulatives, consider using card stock. To make algebra tiles similar to those shown in the Student Edition, have students use markers to color the tiles appropriately or use colored card stock.

You can also make transparencies of frequently used items such as grid paper and number lines.

### **Activity Masters**

Each chapter begins with **Teaching Notes and Overview** that summarizes the activities for the chapter and includes sample answers. There are three types of masters.

**Mini-Projects** are short projects that enable students to independently investigate mathematical concepts.

**Using Overhead Manipulatives** provides instructions for the teacher to demonstrate an alternate approach to the concepts of the lesson by using manipulatives on the overhead projector.

**Student Recording Sheets** accompany the Hands-On Lab Activities found in the Student Edition. Students can easily record the results of the activity on prepared grids, charts, and figures.

# **Glencoe Mathematics Manipulatives**

<b>Glencoe Mathematics Overhead Manipulative Resources</b> ISBN: 0-07-830593-4		
<b>Transparencies</b>		<b>Overhead Manipulatives</b>
integer mat equation mat product mat inequality mat dot paper isometric dot paper coordinate grids	centimeter grid number lines lined paper regular polygons polynomial models integer models equation models	algebra tiles spinners two-dimensional cups red and yellow counters decimal models (base-ten blocks) compass protractor geoboard/geobands geometric shapes transparency pens in 4 colors

<b>Glencoe Mathematics Classroom Manipulative Kit</b> ISBN: 0-02-833116-8		
<b>Algebra</b>	<b>Measurement, Probability, and Statistics</b>	<b>Geometry</b>
algebra tiles counters cups centimeter cubes equation mat/product mat coordinate grid stamp and ink pad	base-ten models marbles measuring cups number cubes protractors rulers scissors spinners stopwatches tape measures	compasses geoboards geobands geomirrors isometric dot grid stamp pattern blocks tangrams

<b>Glencoe Mathematics Student Manipulative Kit</b> ISBN: 0-02-833654-2	
algebra tiles red and yellow counters cups equation /product mat compass/ruler	protractor scissors geoboard geobands tape measure

NAME \_\_\_\_\_

# Base-Ten Models





--	--	--	--	--	--	--	--	--	--

NAME \_\_\_\_\_

# Decimal Models

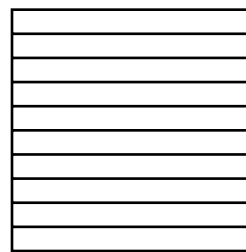
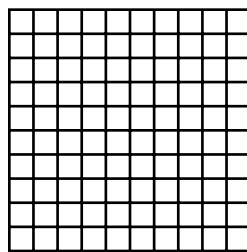
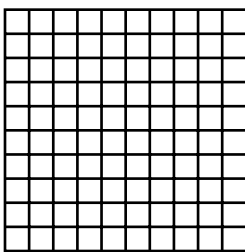
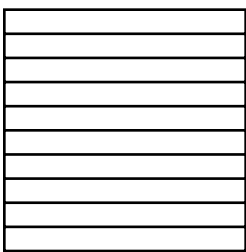
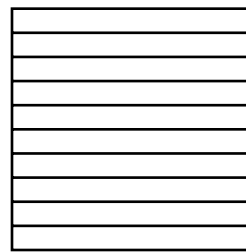
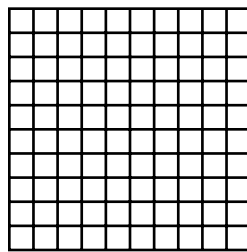
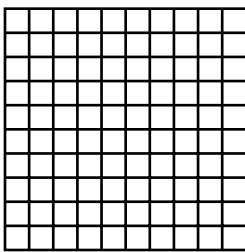
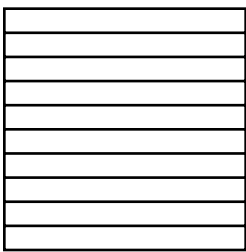
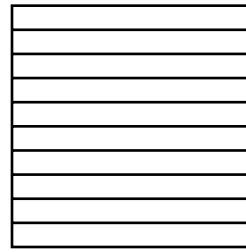
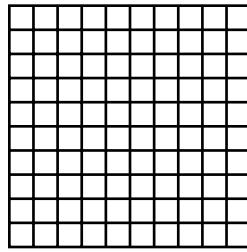
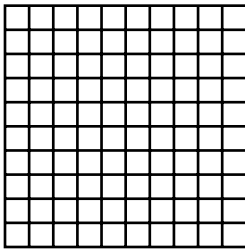
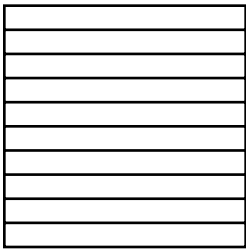
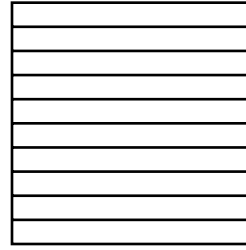
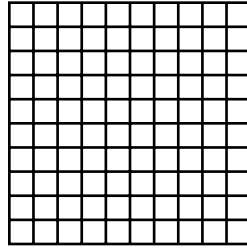
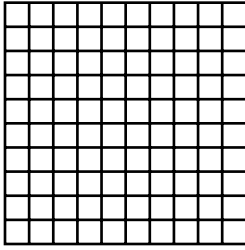
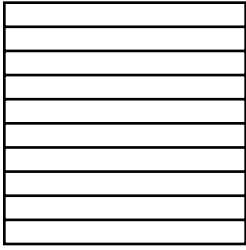
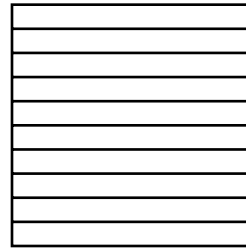
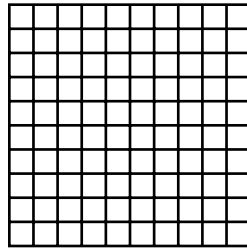
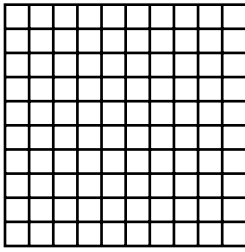
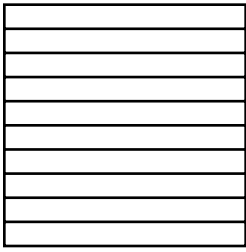



NAME \_\_\_\_\_

## Fraction Models: Bars

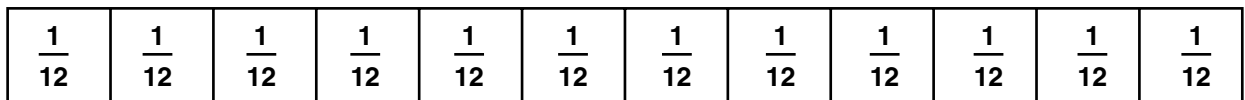
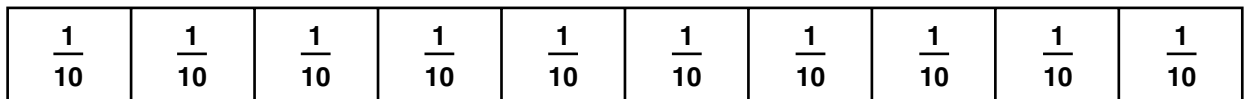
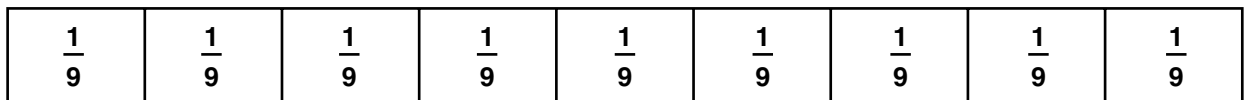
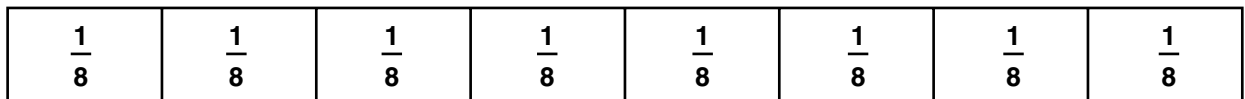
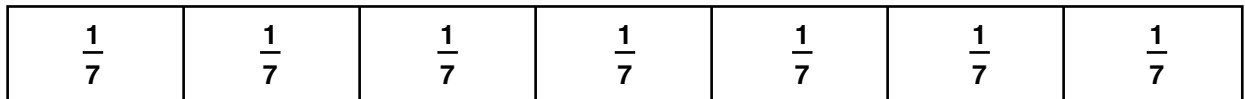
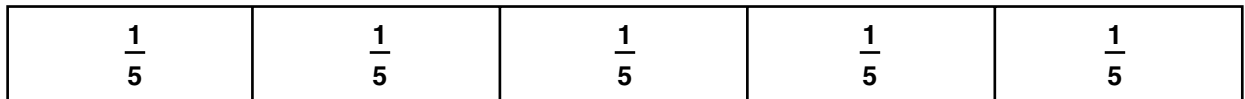
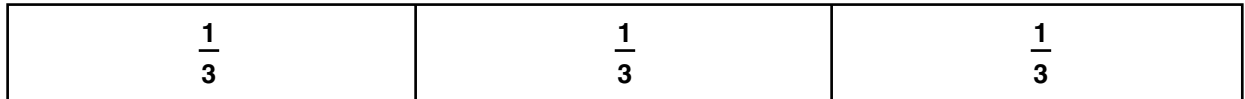

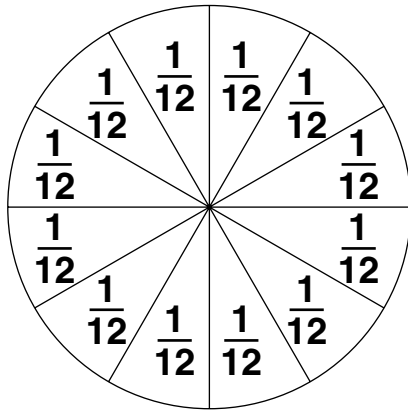
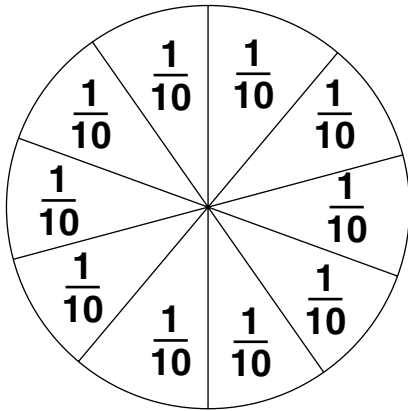
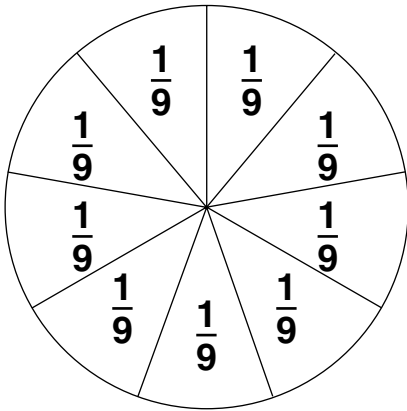
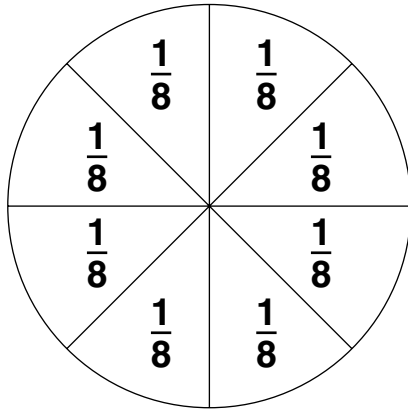
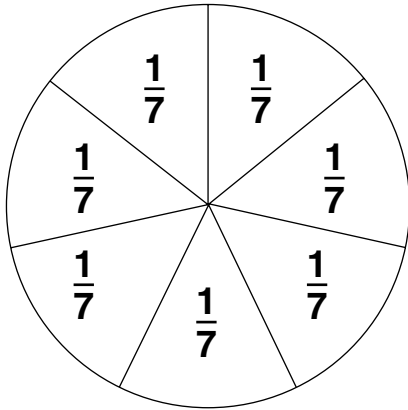
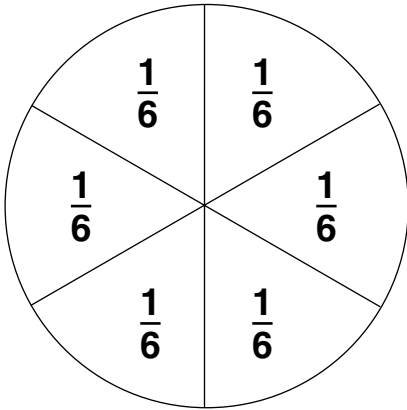
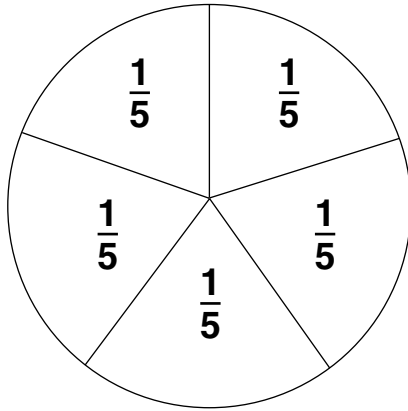
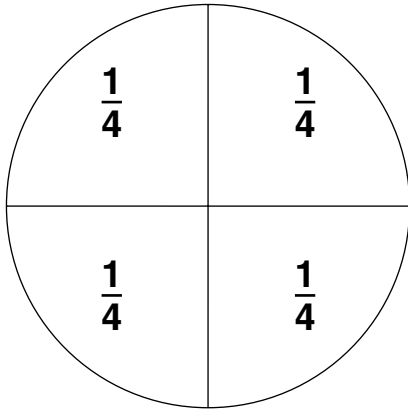
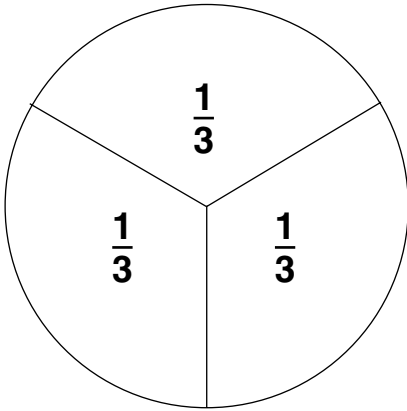
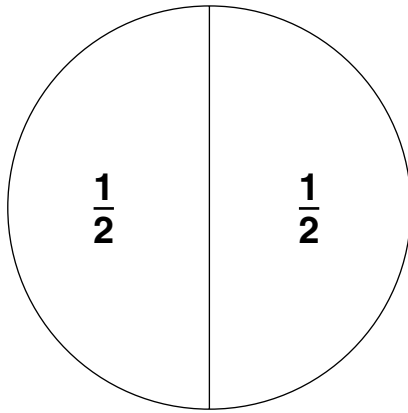
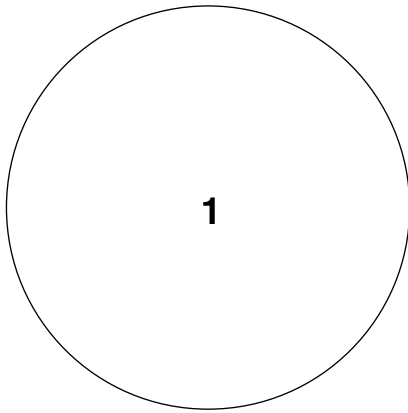
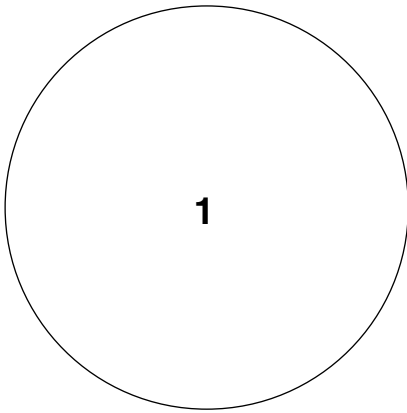

NAME \_\_\_\_\_

# Counters

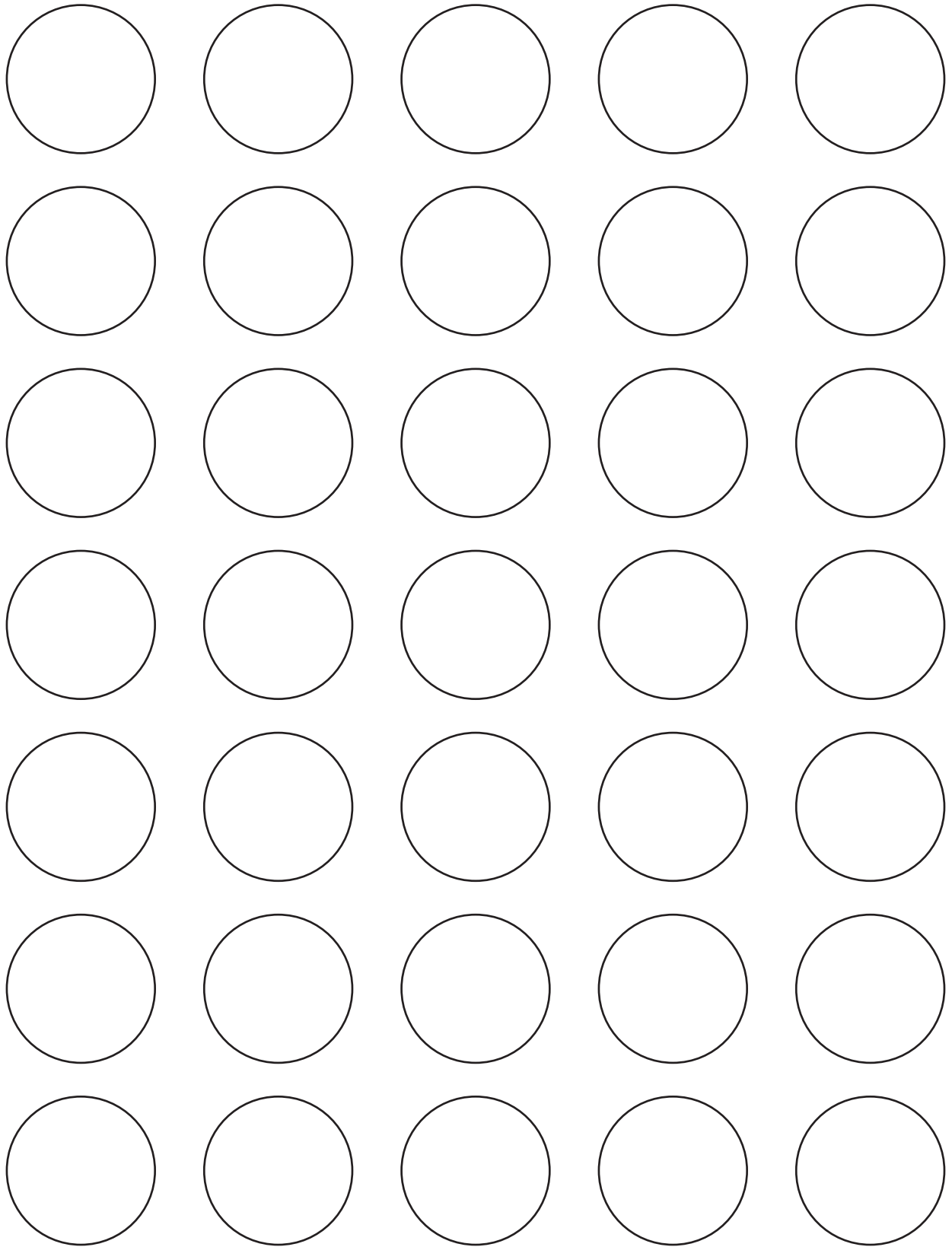

NAME \_\_\_\_\_

# Integer Counters

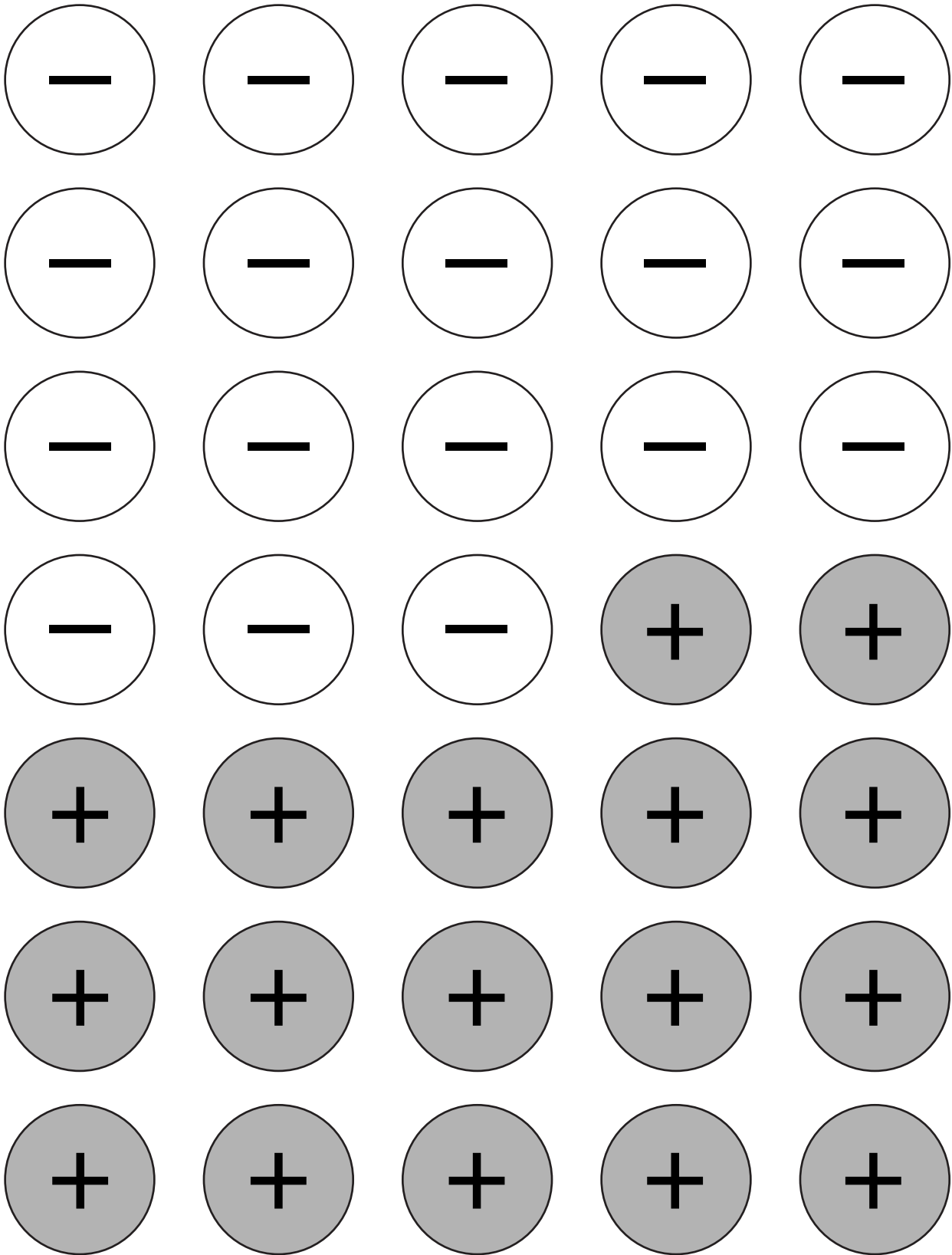

NAME \_\_\_\_\_

# Pattern for Cup

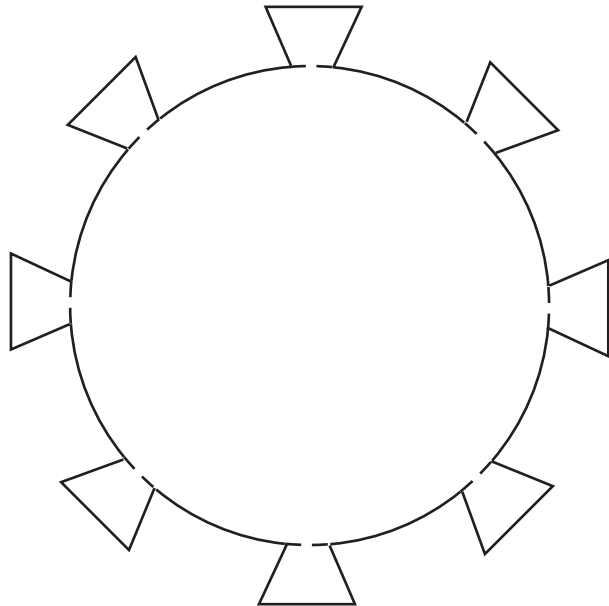
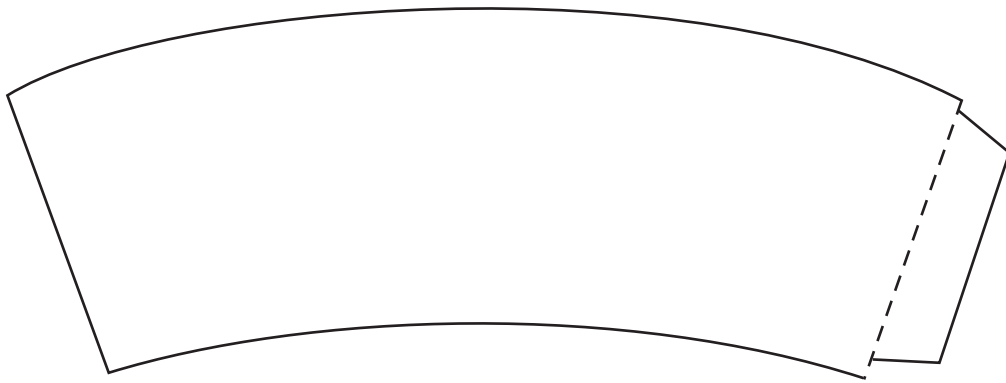
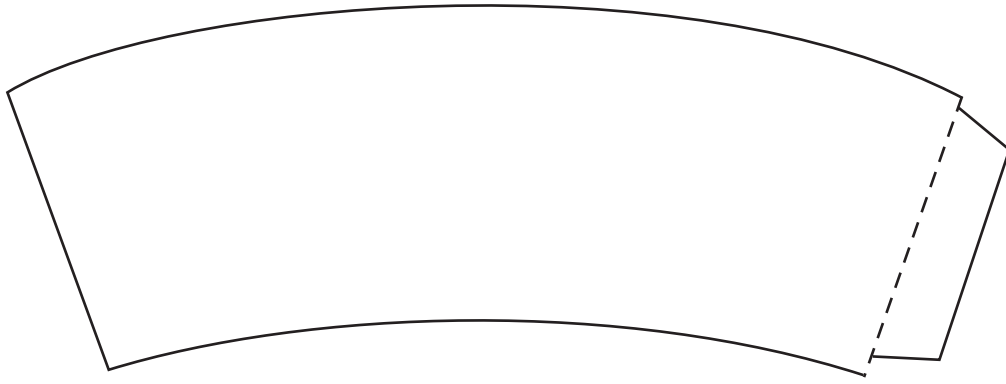

NAME \_\_\_\_\_

***Integer Mat***

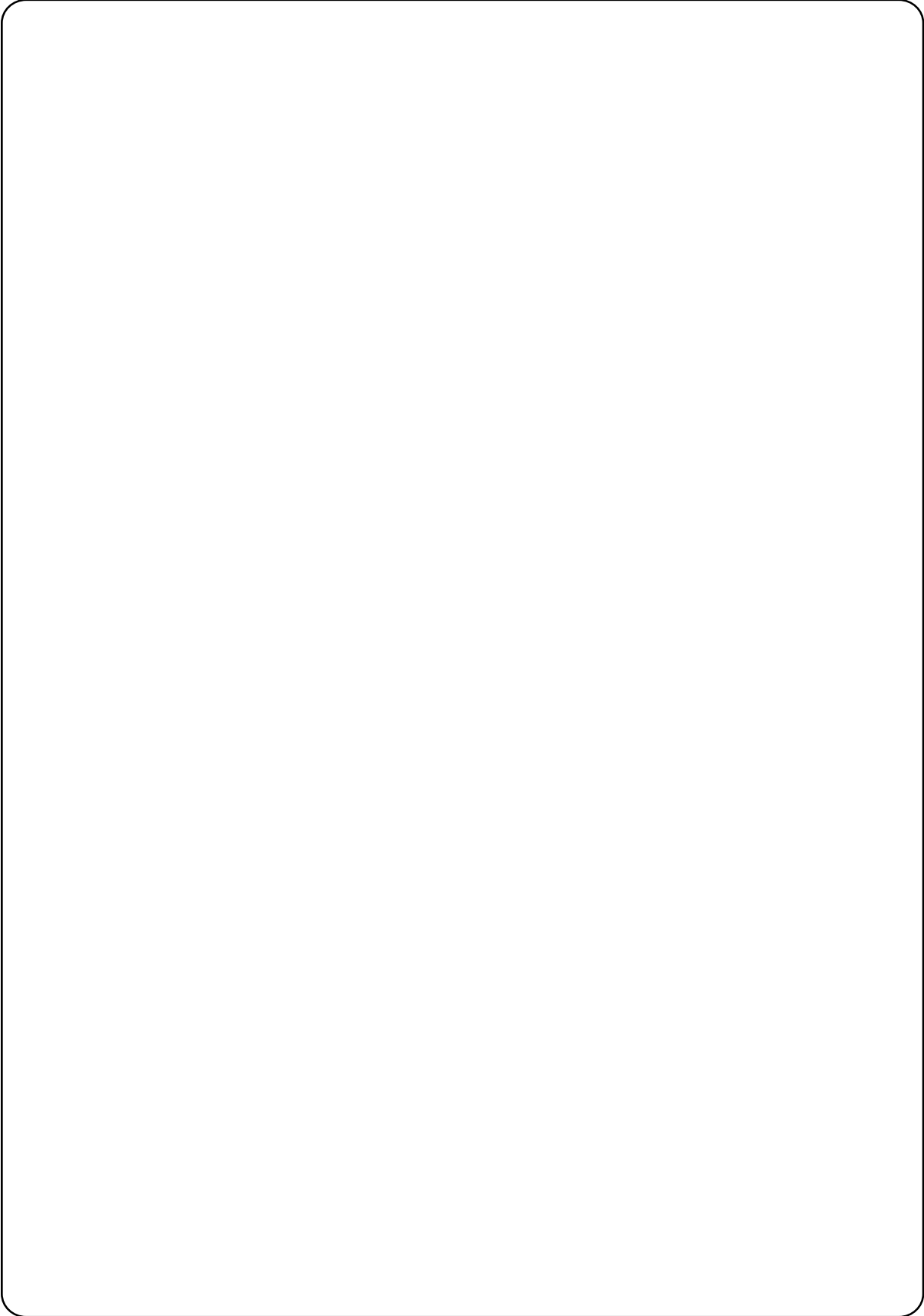

NAME \_\_\_\_\_

# Equation Mat



||



NAME \_\_\_\_\_

# Quarter-Inch Grid

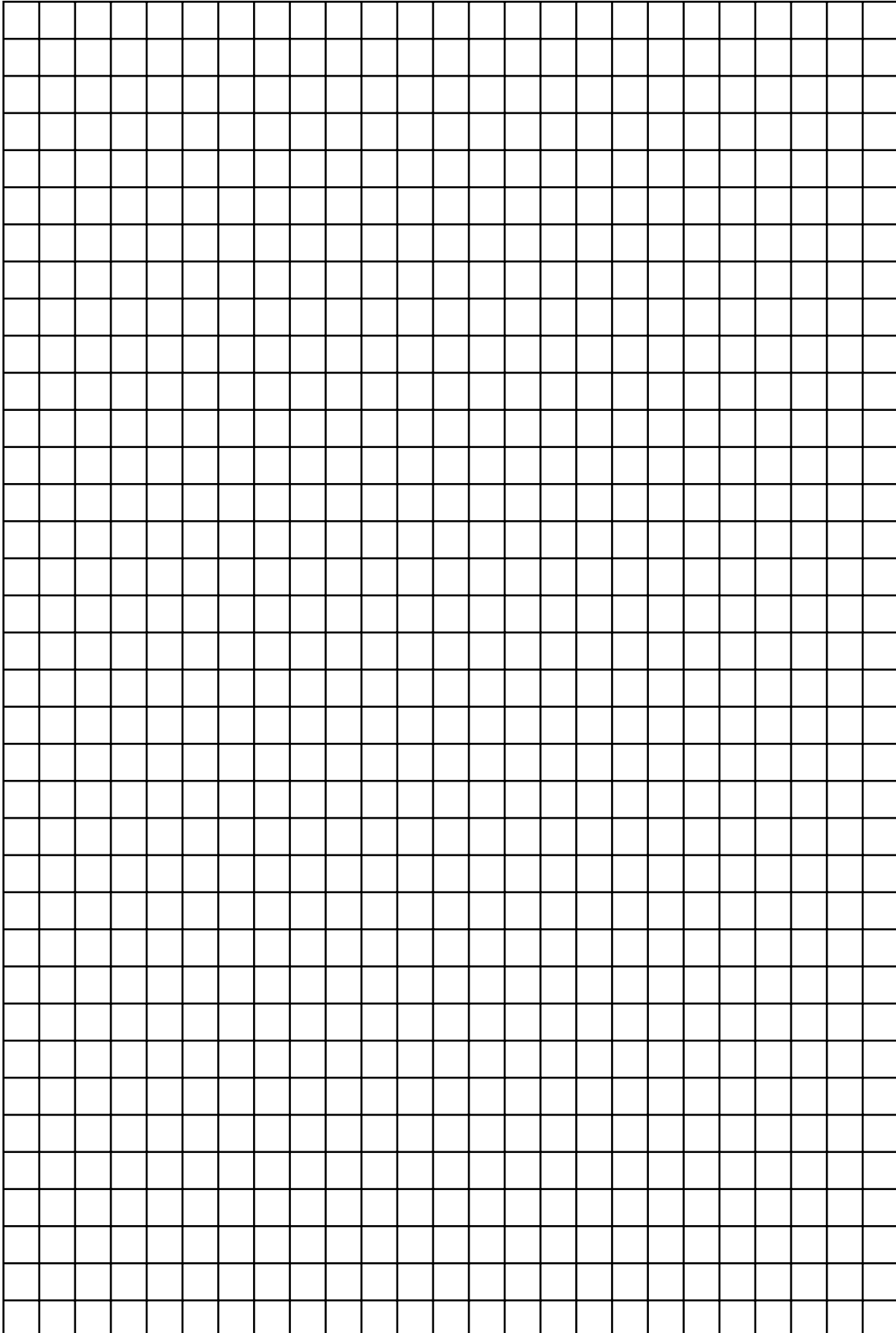



NAME \_\_\_\_\_

# Centimeter Grid

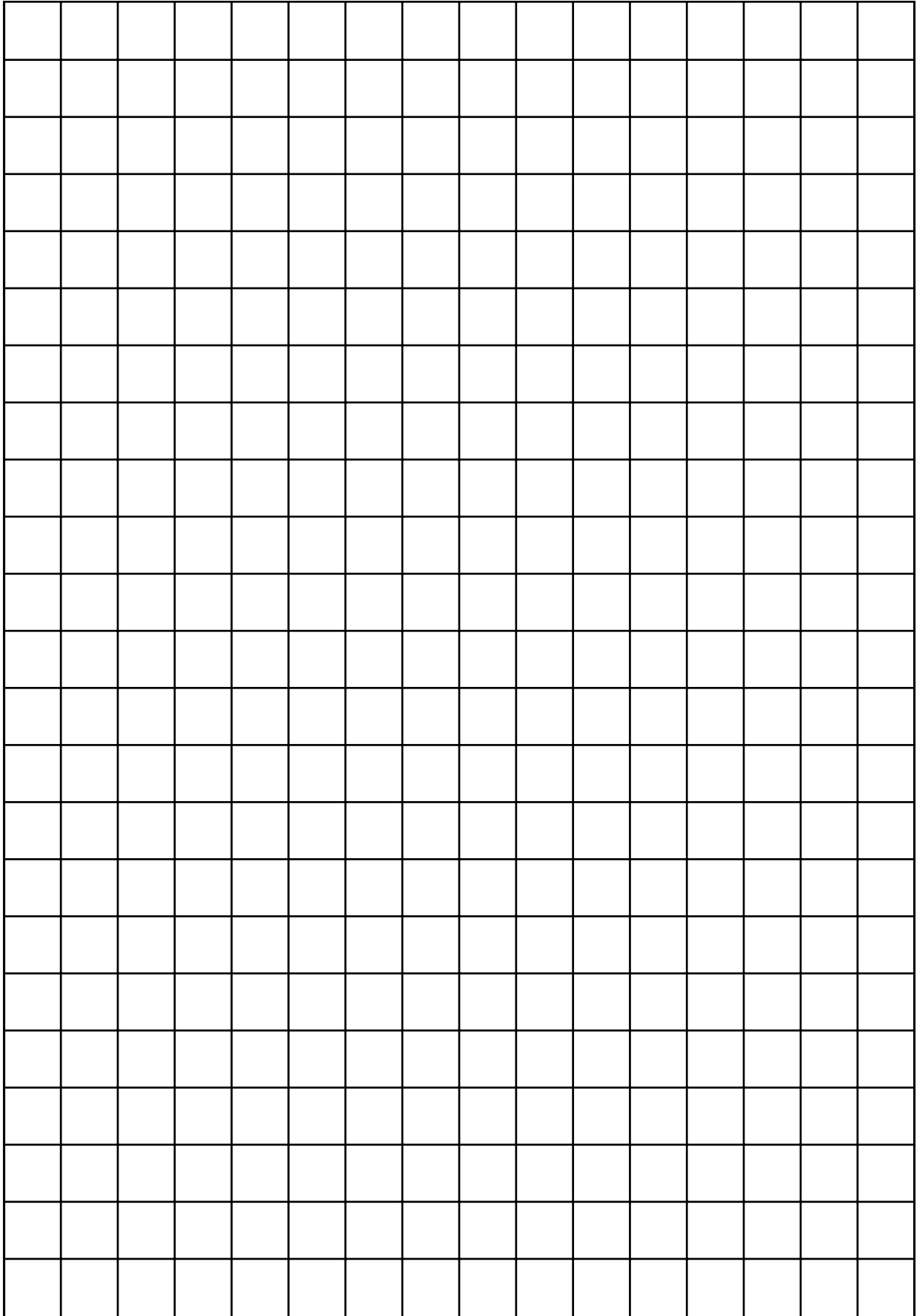

NAME \_\_\_\_\_

# Square Dot Paper

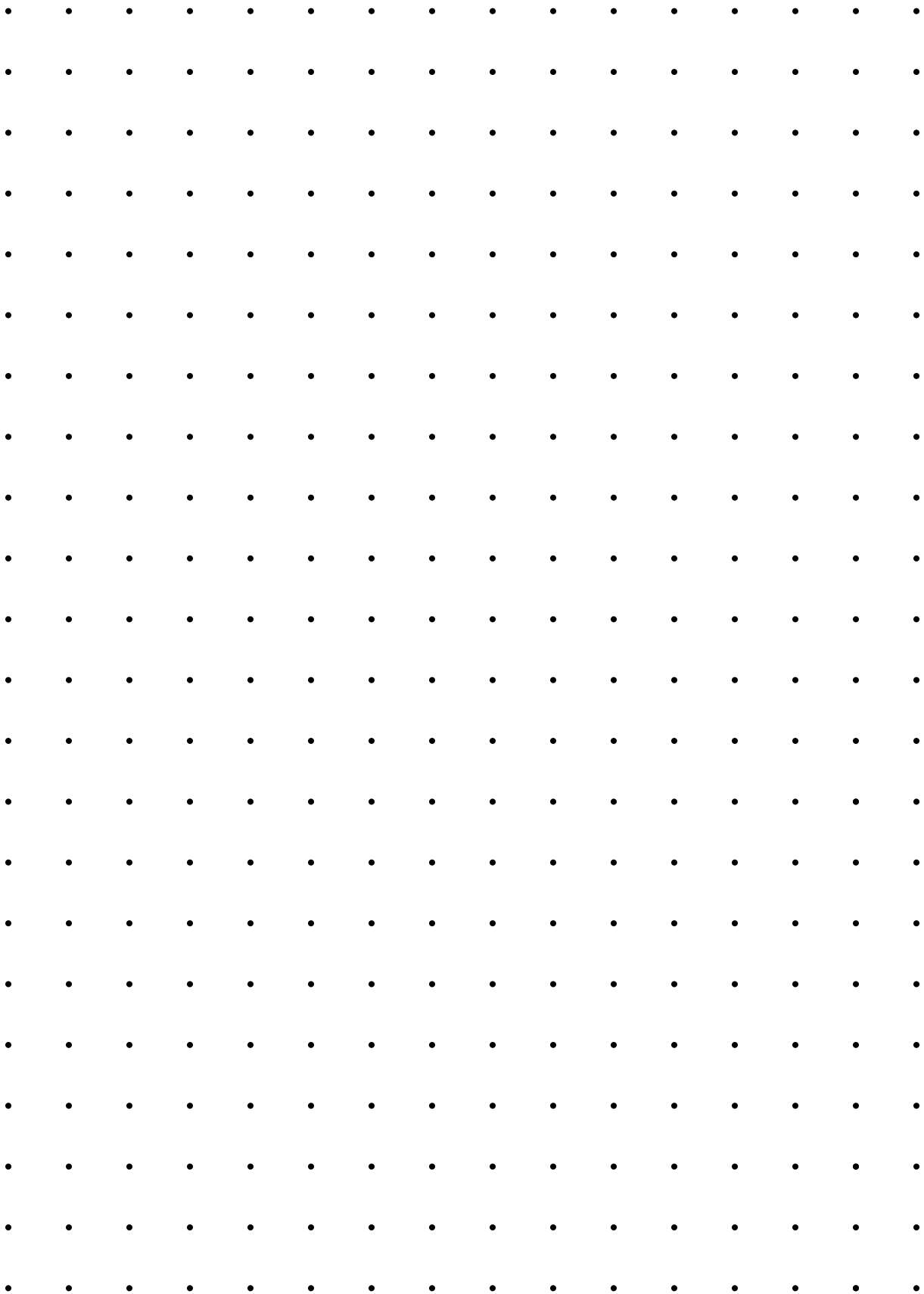

NAME \_\_\_\_\_

# Isometric Dot Paper

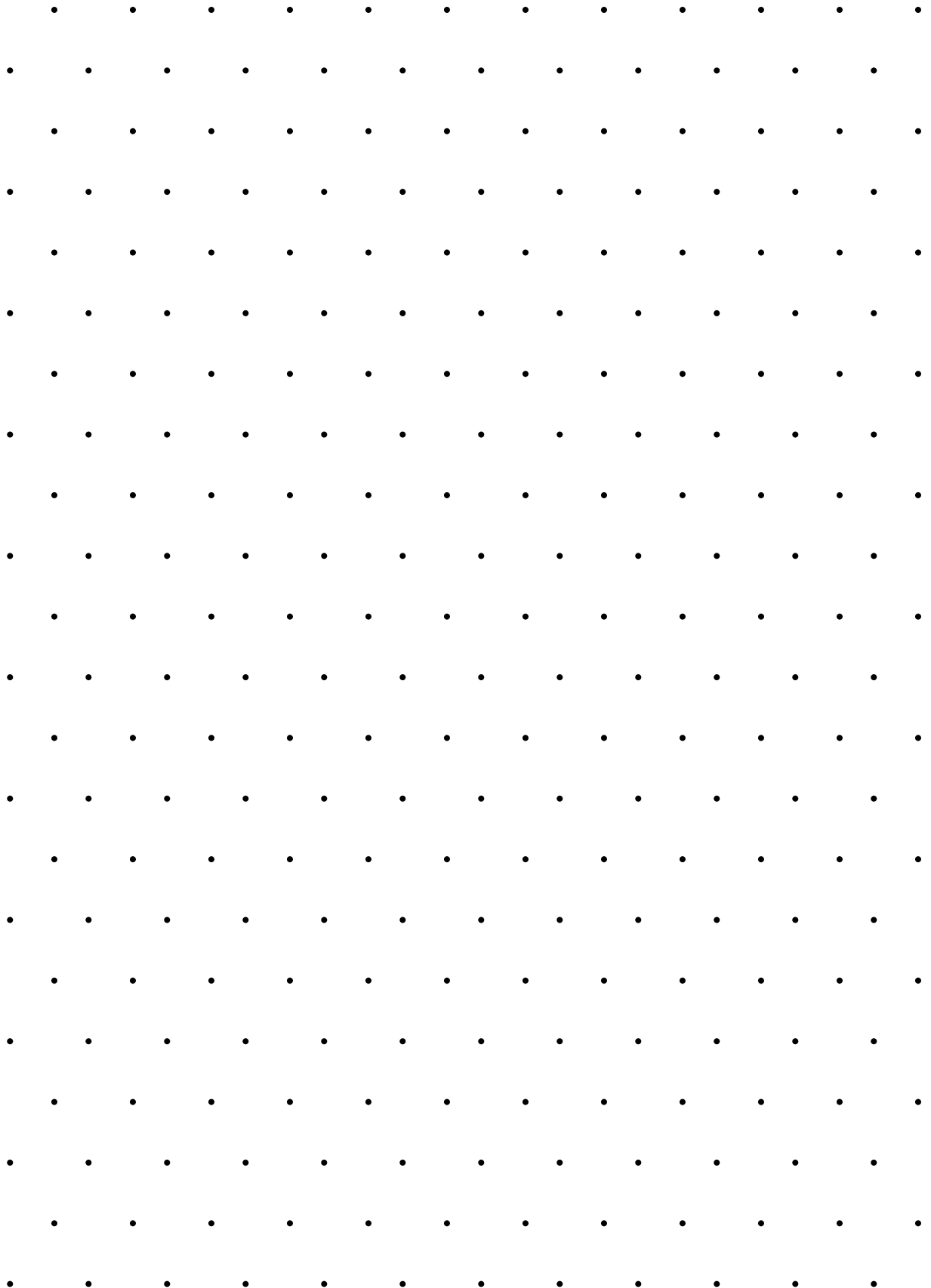

NAME \_\_\_\_\_

# Tangram

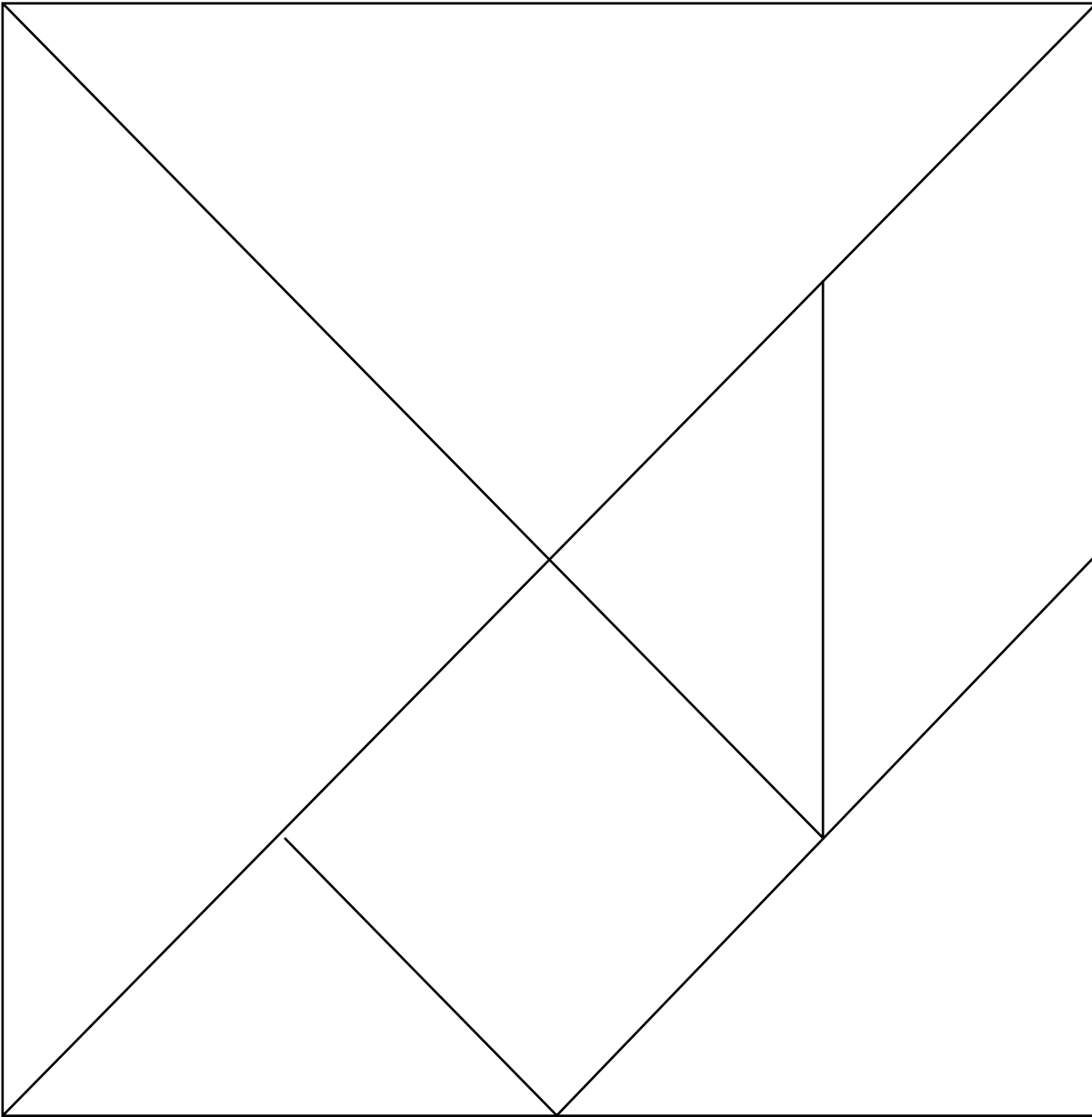

NAME \_\_\_\_\_

# Number Lines

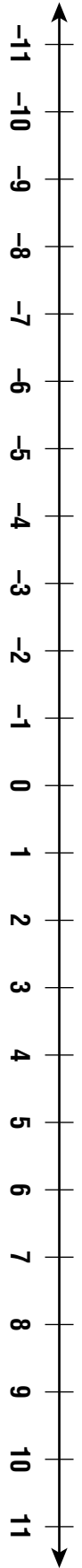
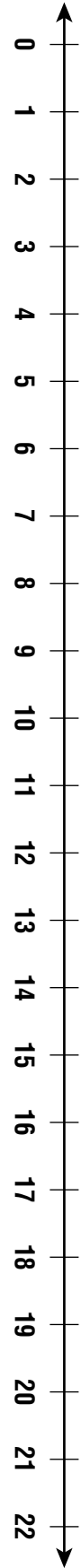
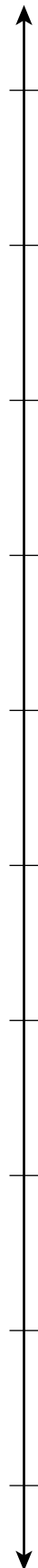
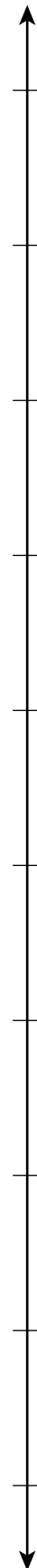
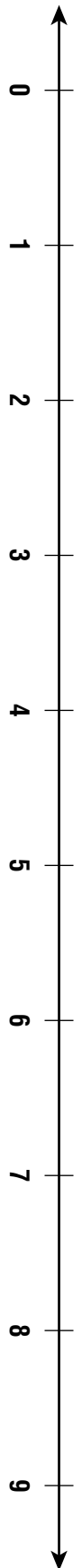

NAME \_\_\_\_\_

# First-Quadrant Grids

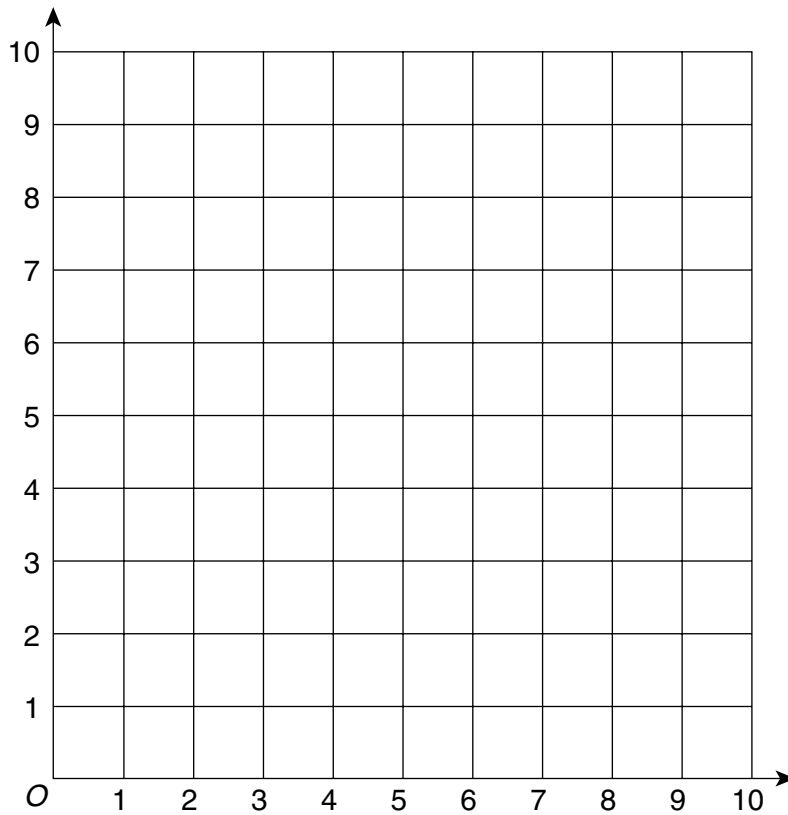
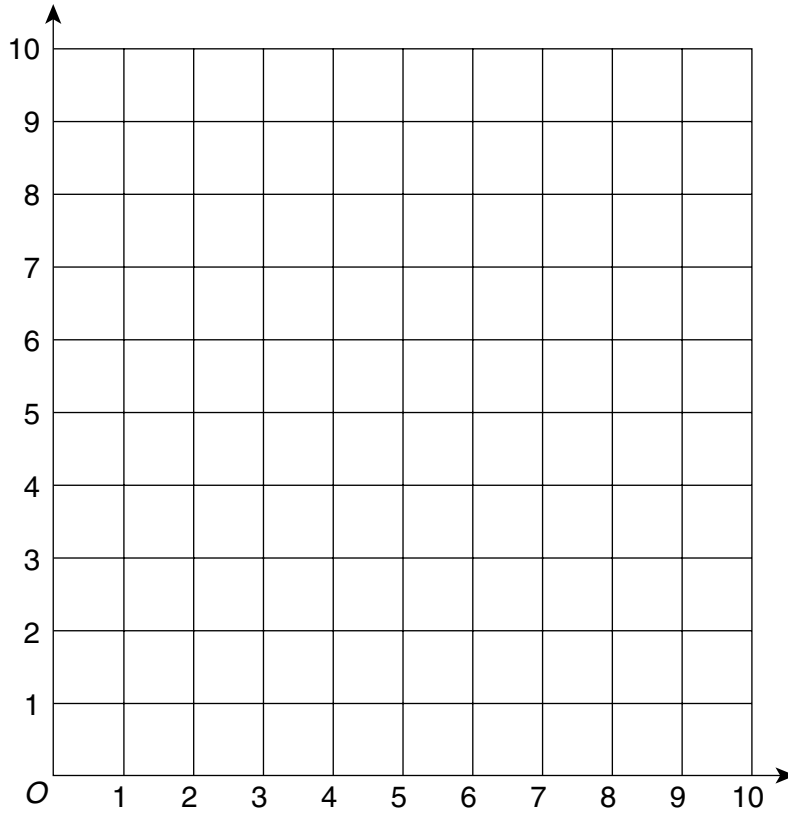

NAME \_\_\_\_\_

# Coordinate Planes

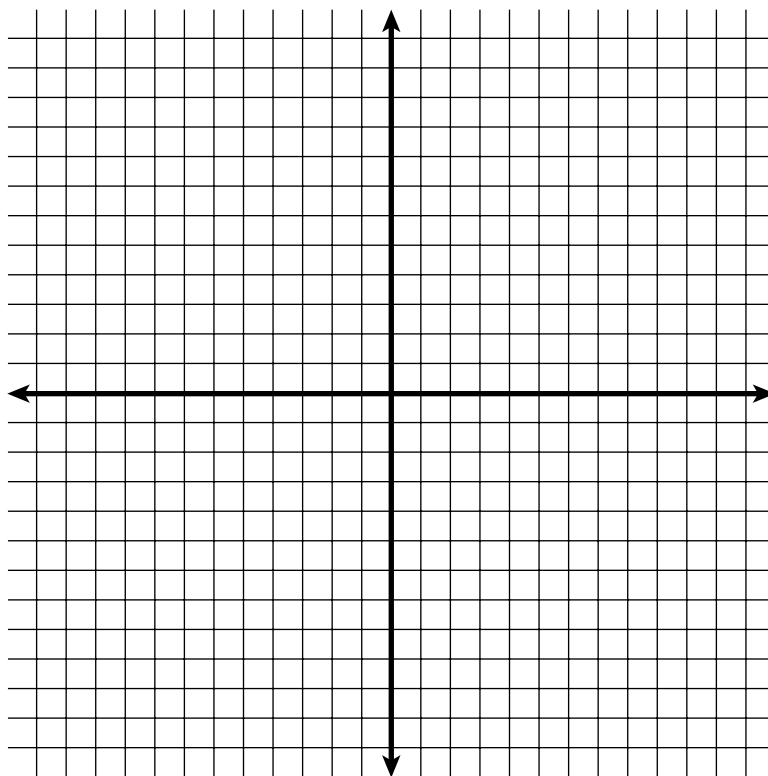
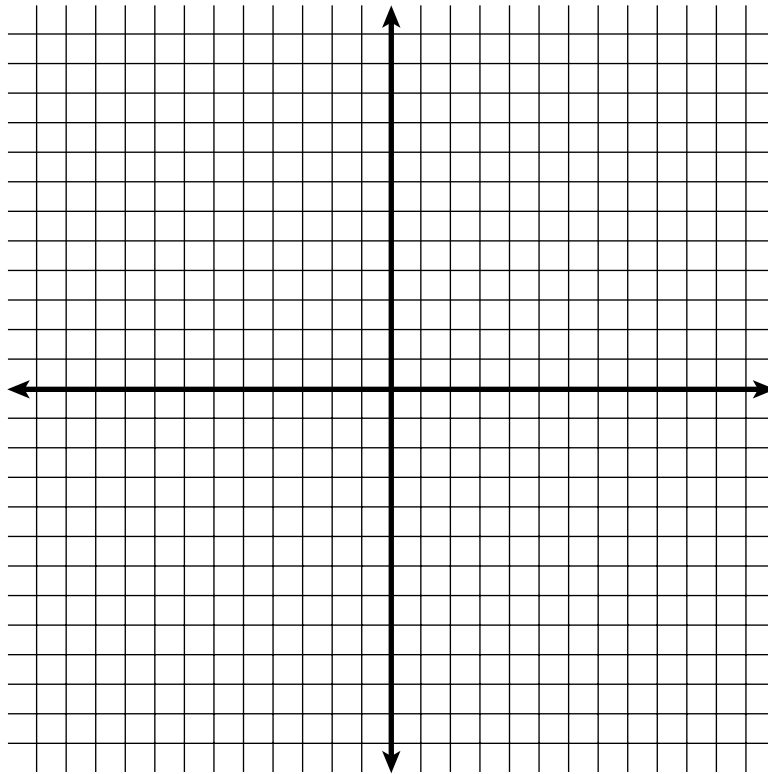

NAME \_\_\_\_\_

# Percent Models

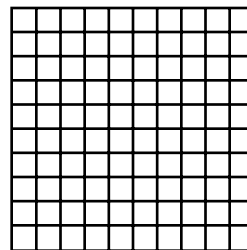
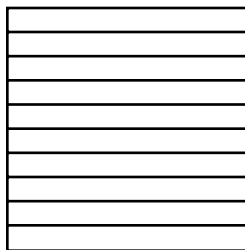
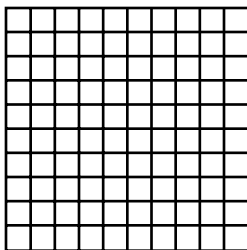
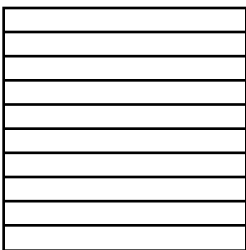
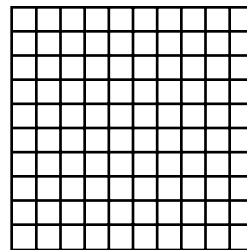
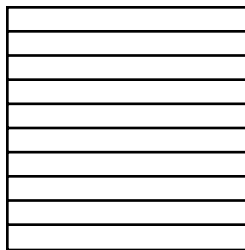
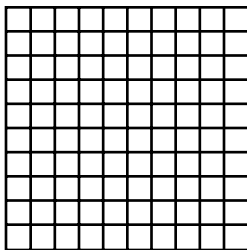
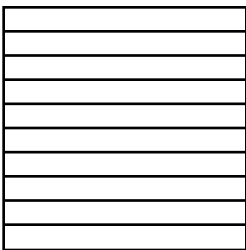
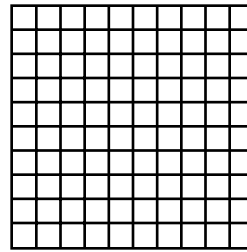
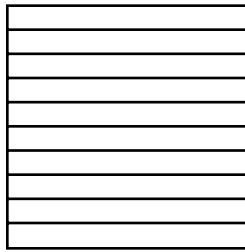
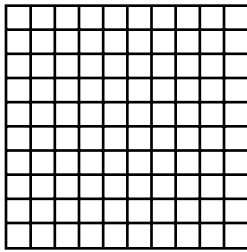
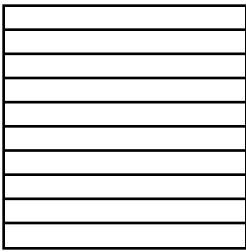
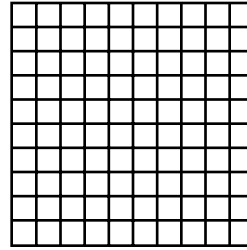
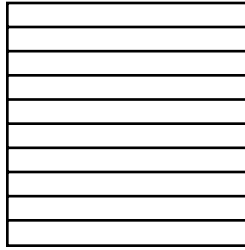
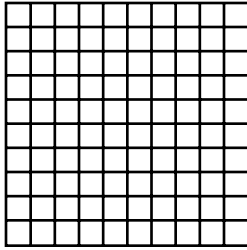
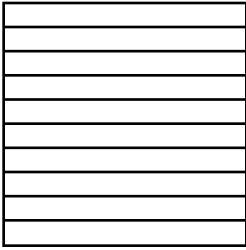
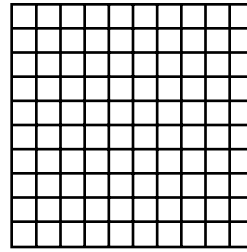
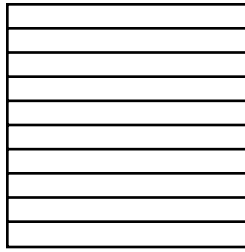
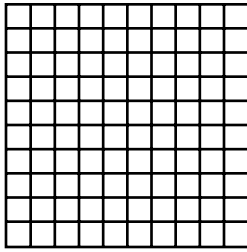
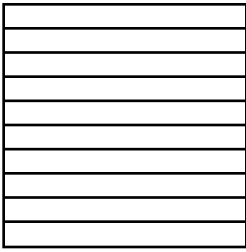



NAME \_\_\_\_\_

# Spinners

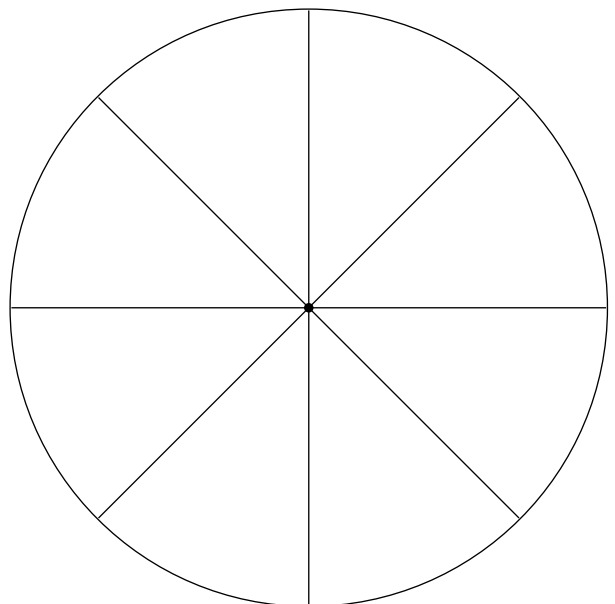
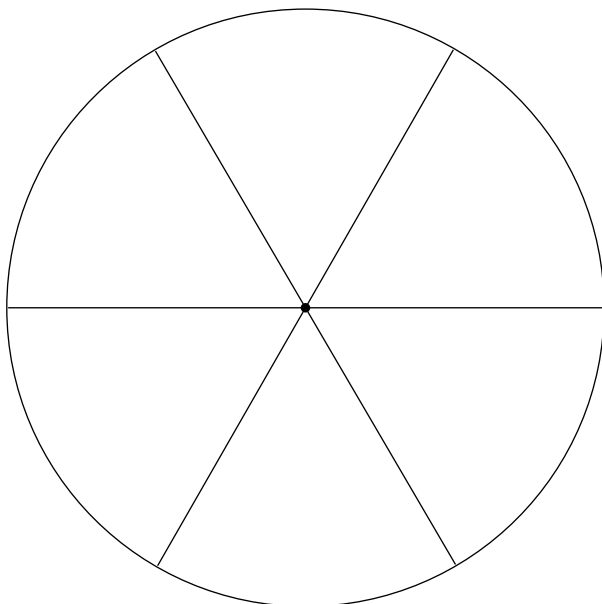
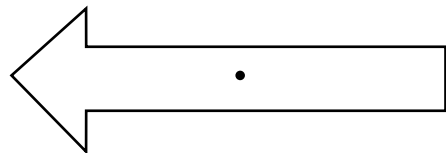
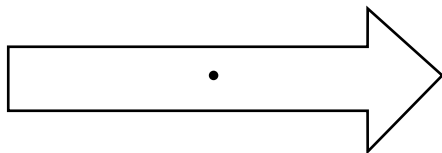
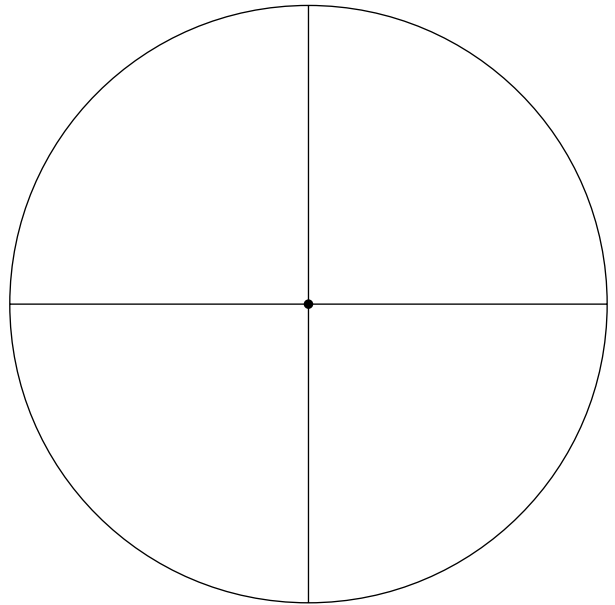
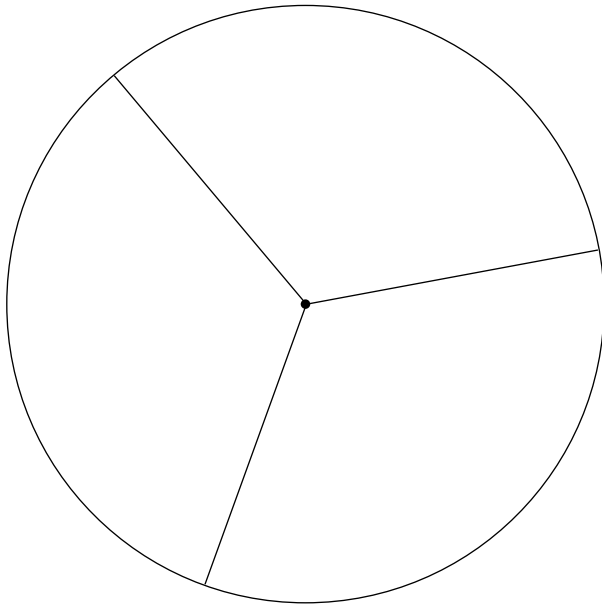
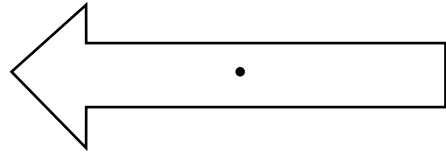
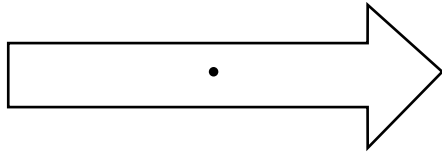

NAME \_\_\_\_\_

# Number Cube Patterns

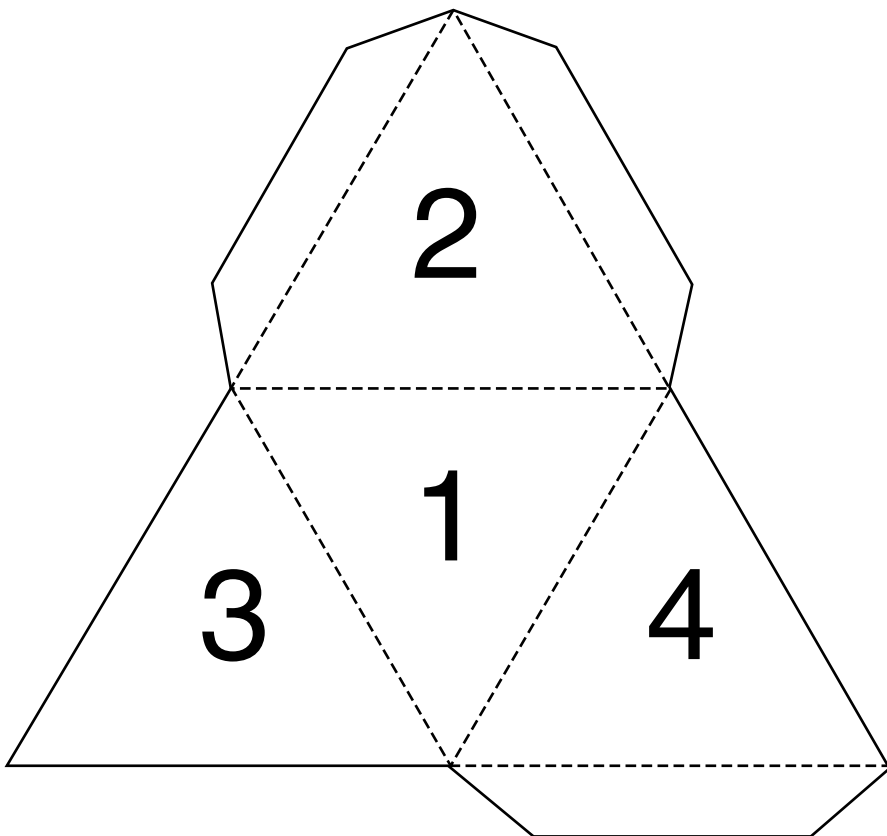
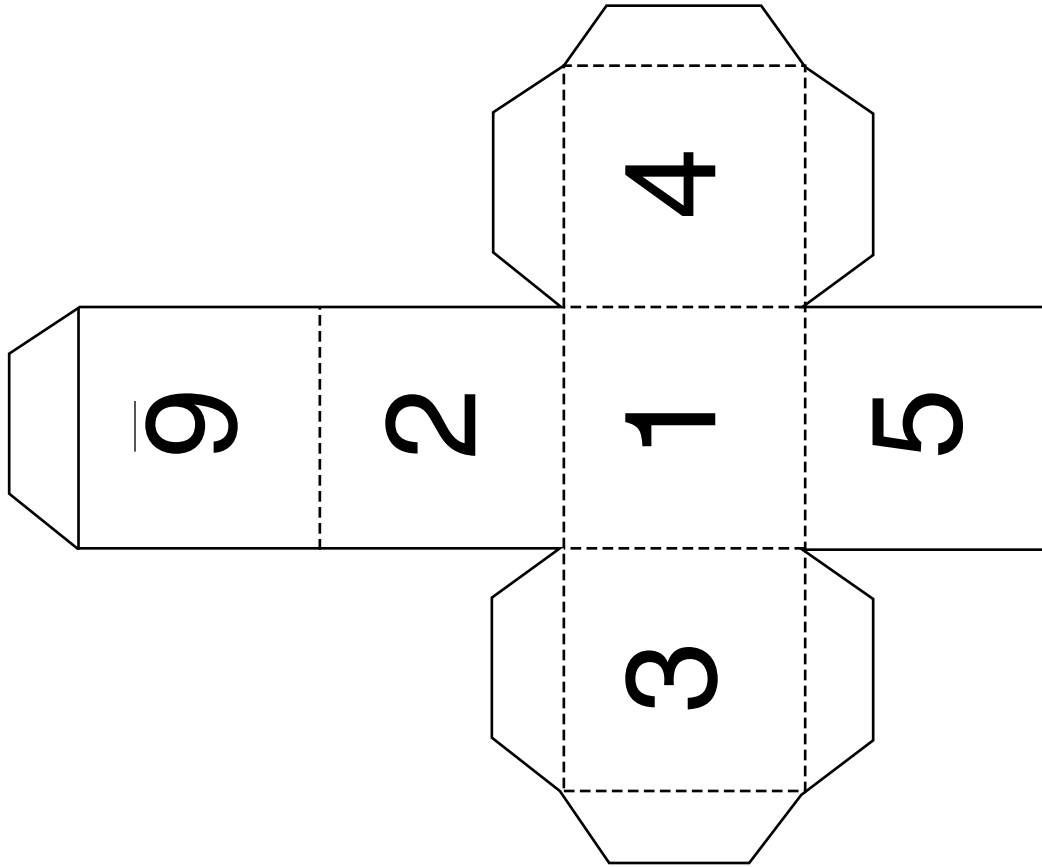

NAME \_\_\_\_\_

# Protractors

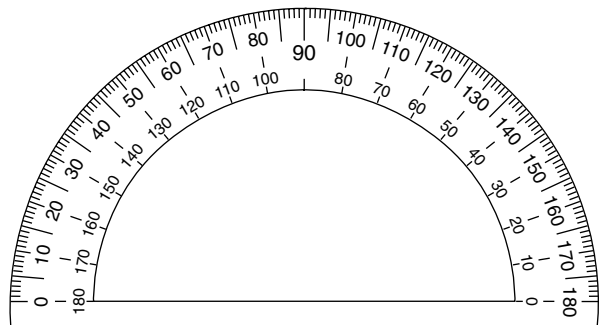
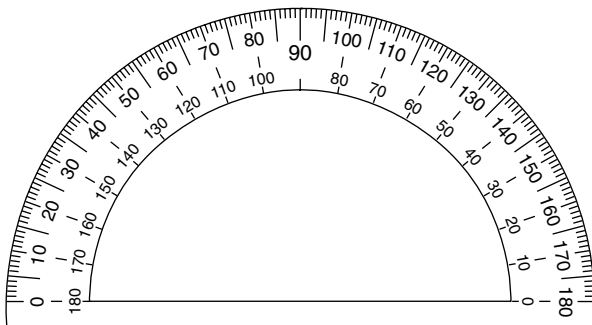
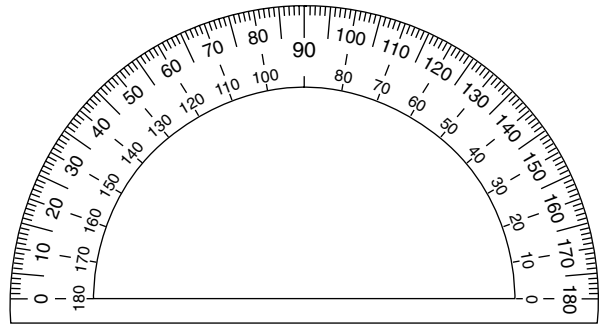
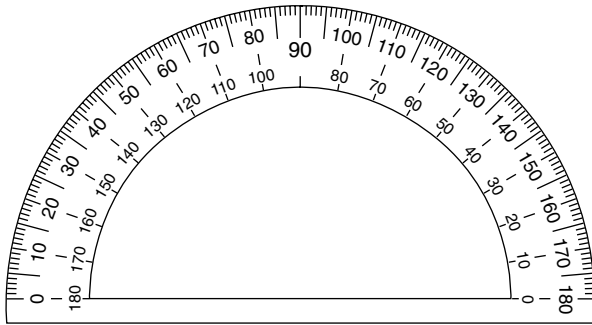
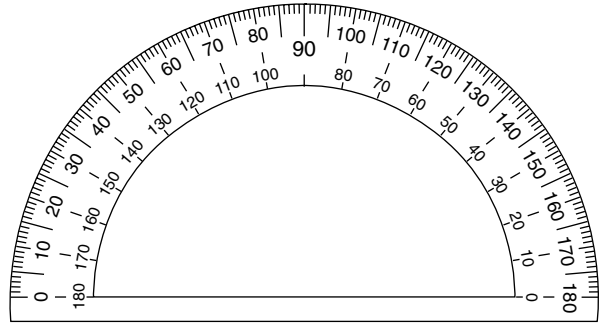
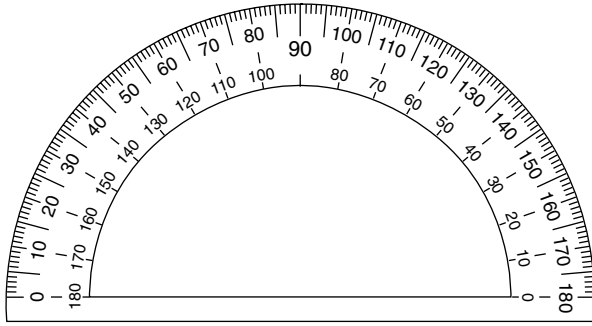

NAME \_\_\_\_\_

# Rectangular Prism Pattern

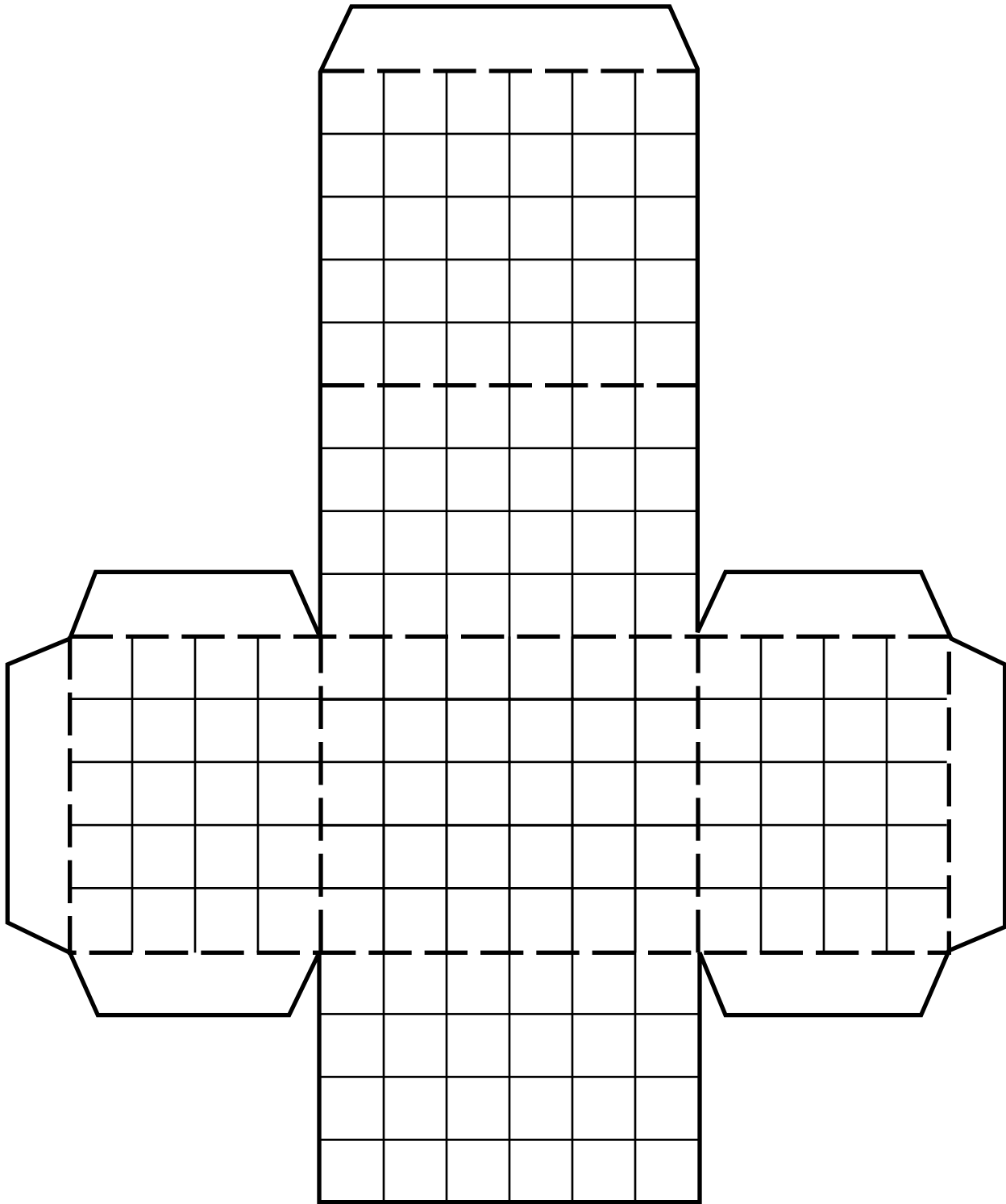

NAME \_\_\_\_\_

# Cube Pattern

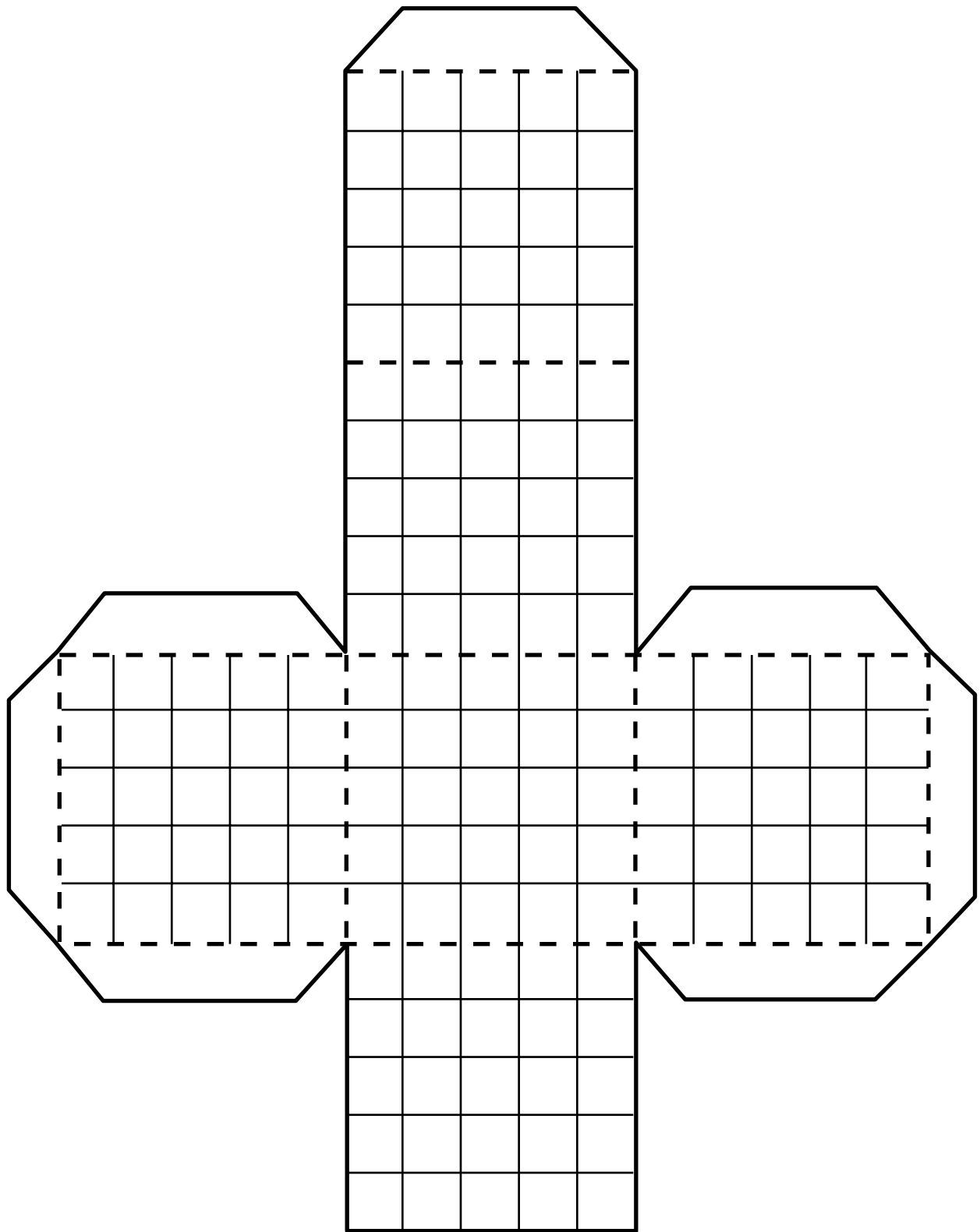

NAME \_\_\_\_\_

# Cylinder Pattern

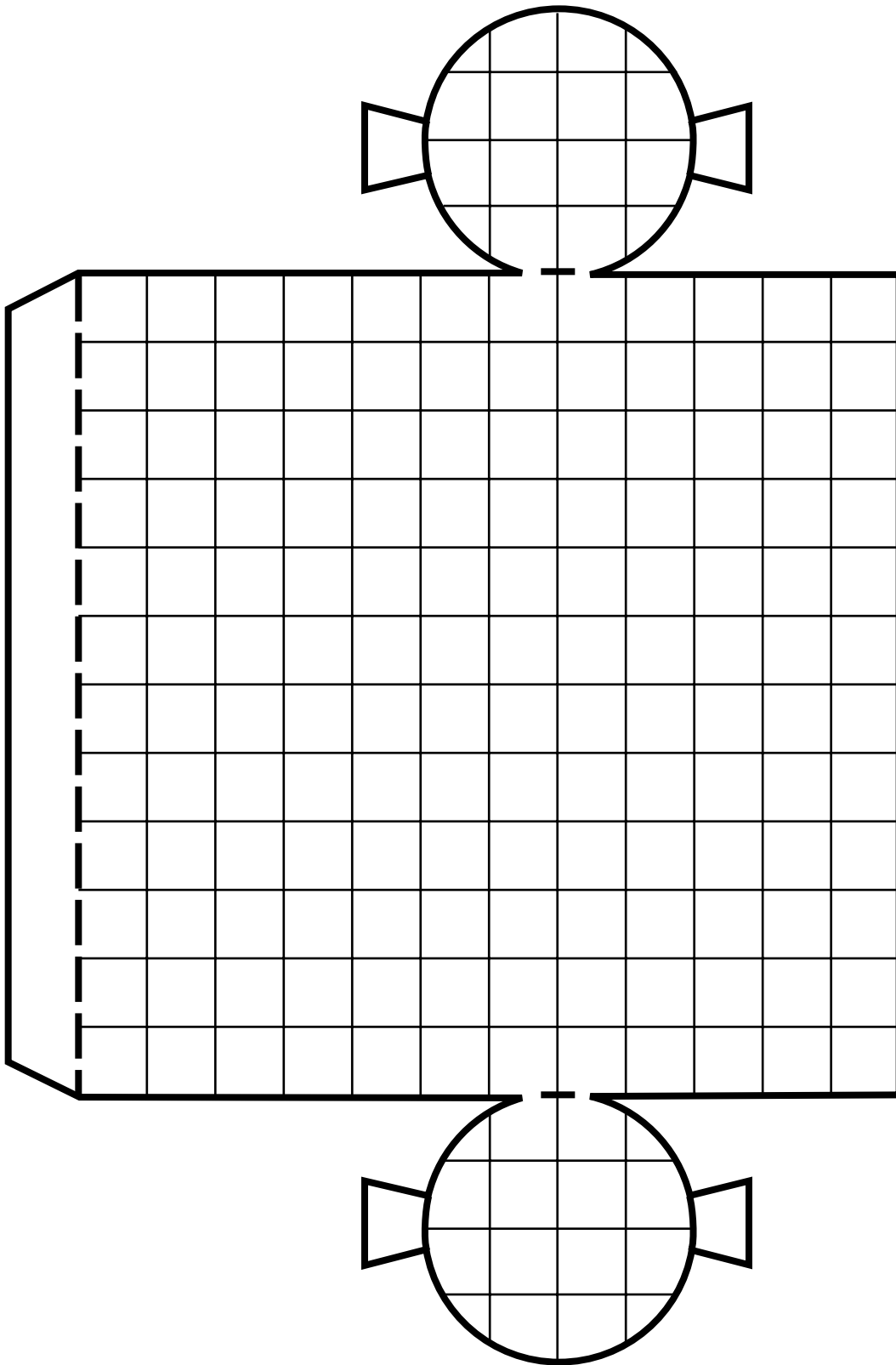

NAME \_\_\_\_\_

# Cone Pattern

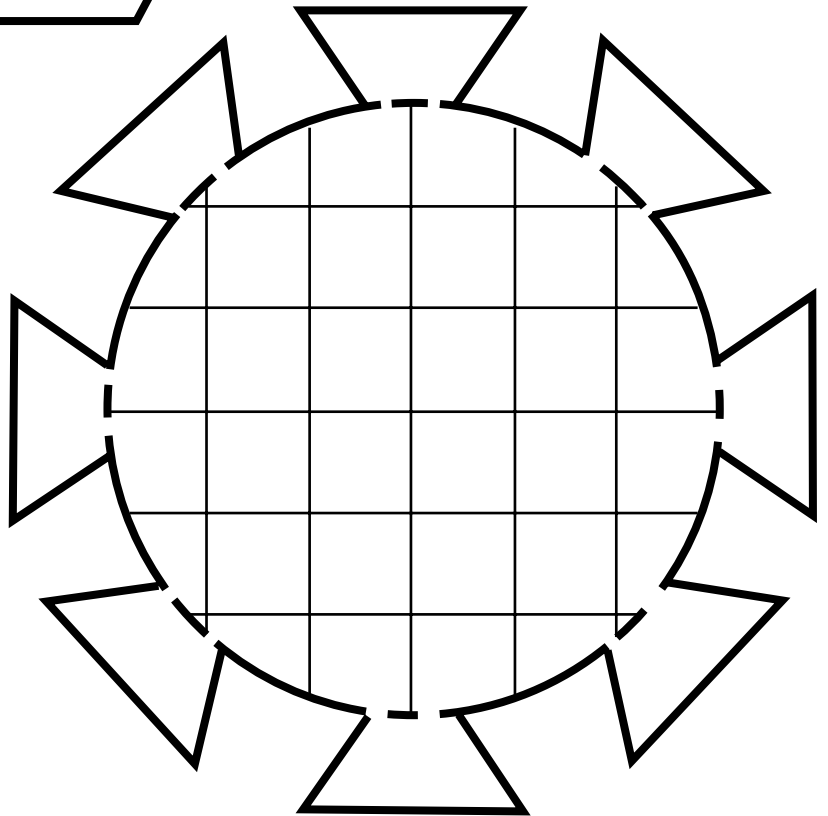
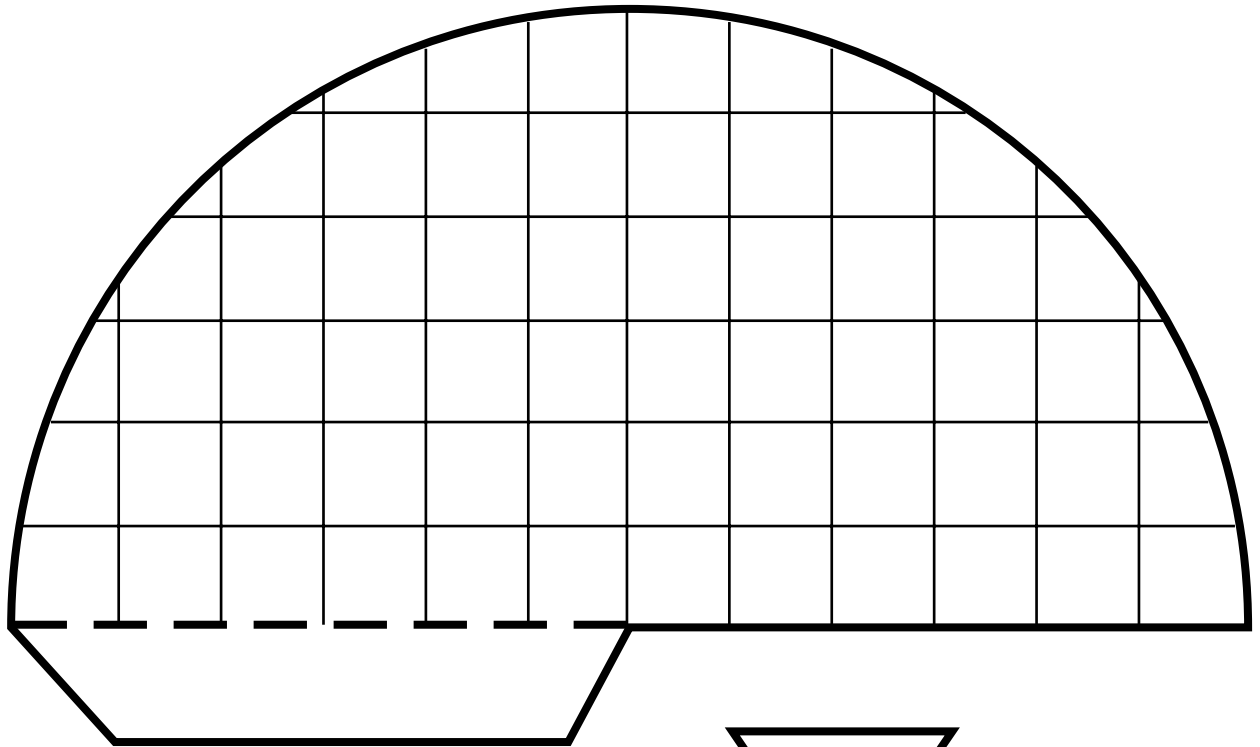

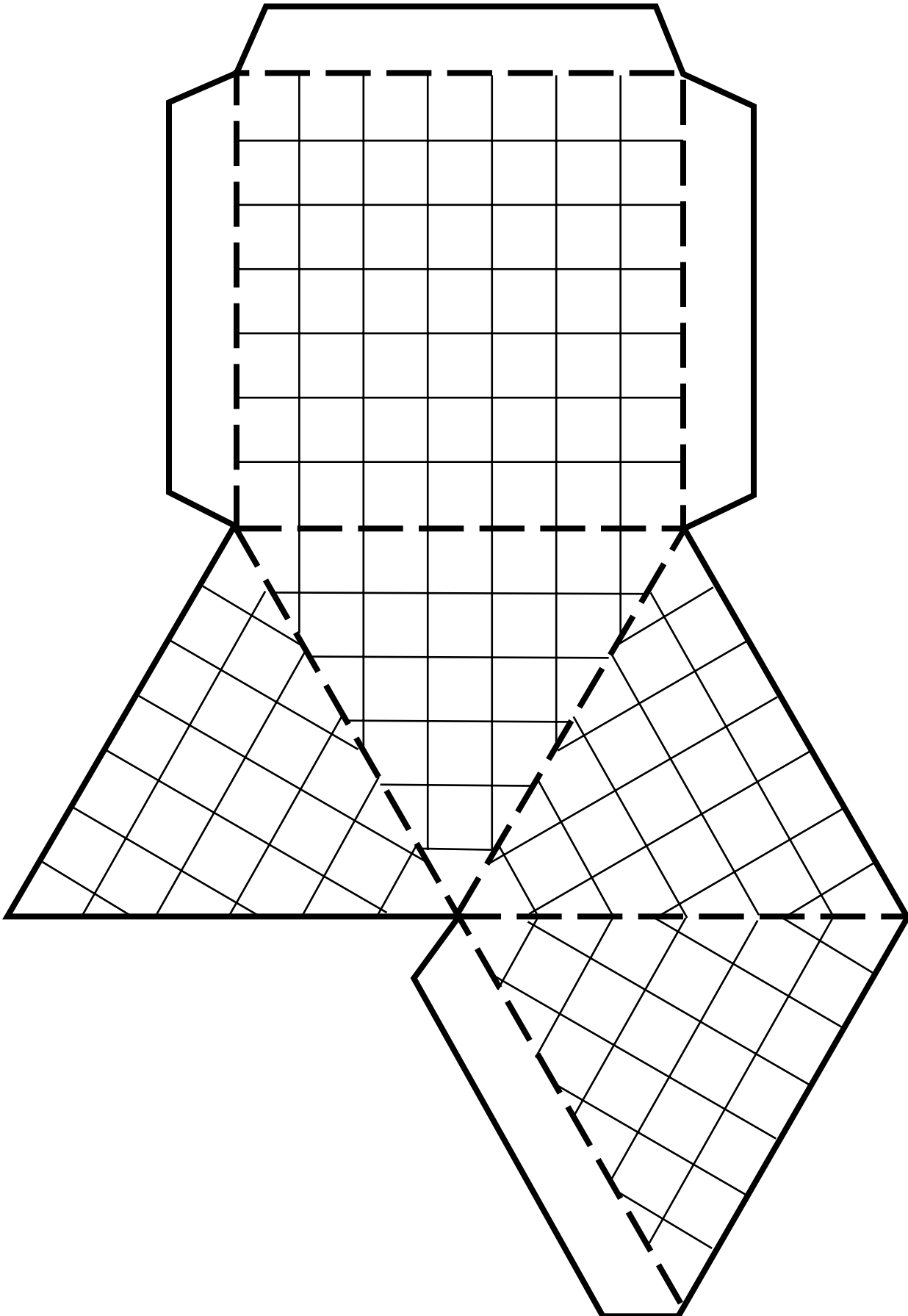



NAME \_\_\_\_\_

# Pattern Blocks

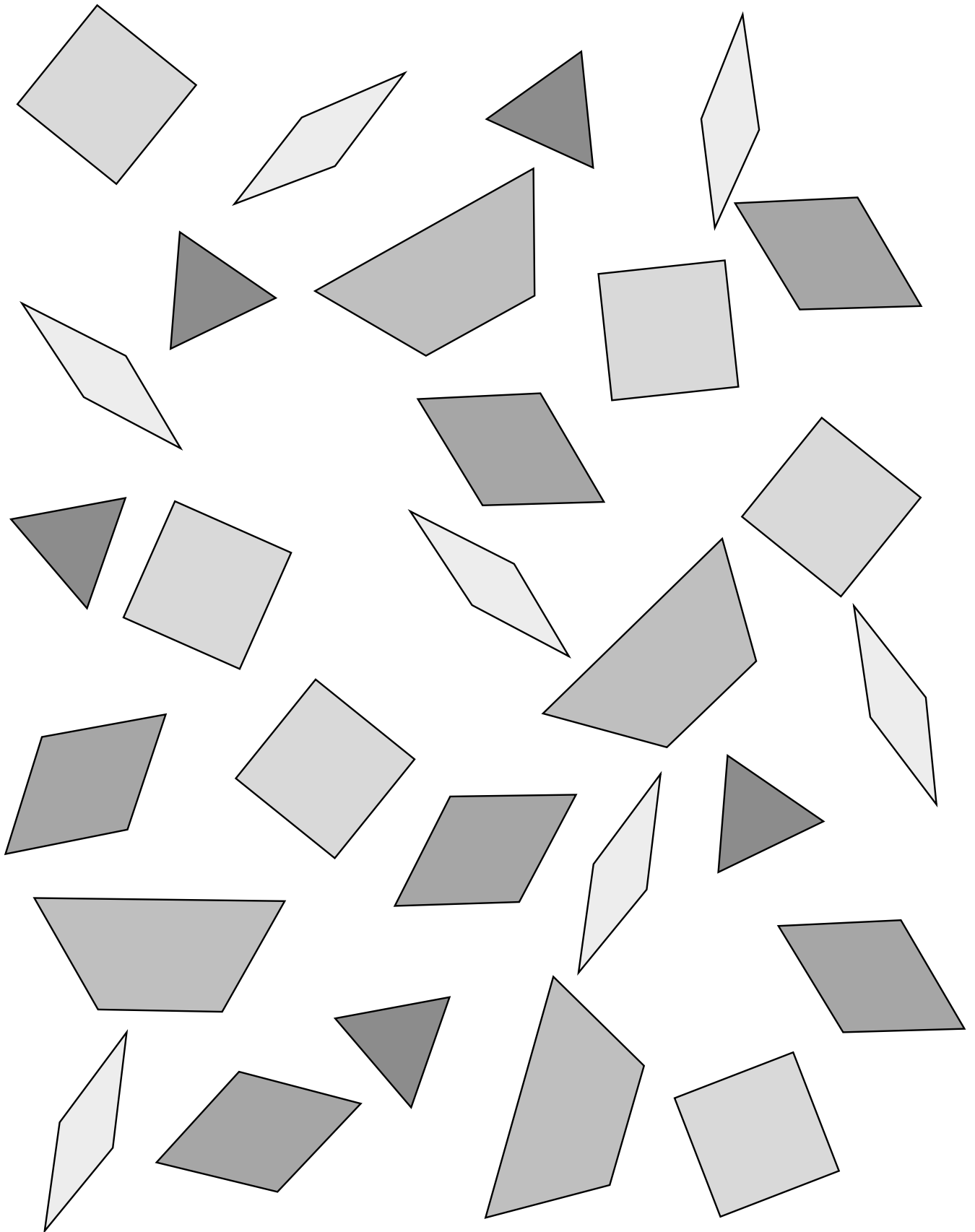

NAME \_\_\_\_\_

# Circle Graph Template

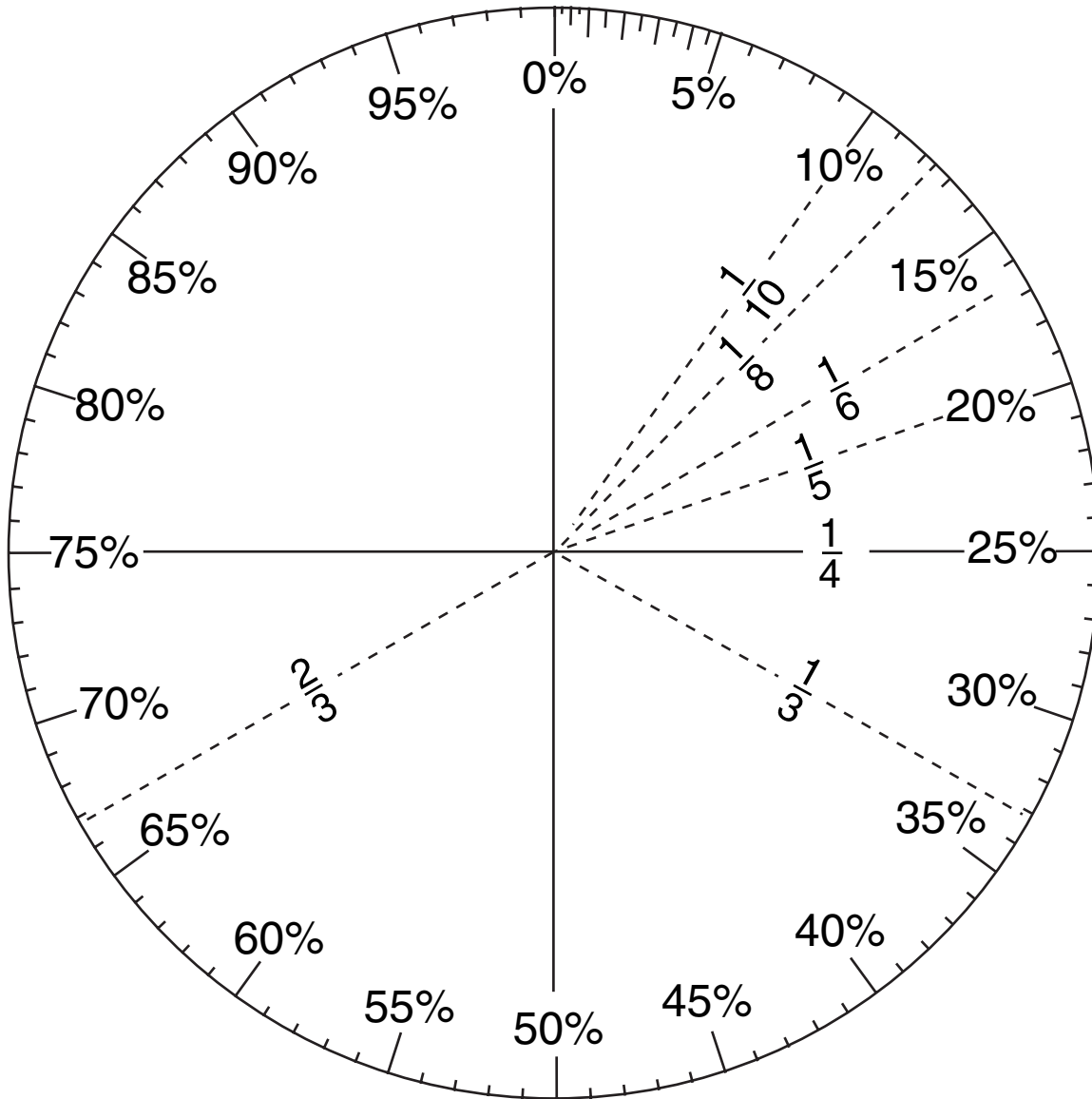

Problem:

**Explore**

**Plan**

**Solve**

**Examine**

**These steps  
can help  
you solve  
problems.**

# Decimal Patterns and Algebra

## Teaching Notes and Overview



### Mini-Project

#### Modeling Powers and Exponents

(p. 31 of this booklet)

**Use With** Lesson 1-2.

**Objective** Use centimeter cubes to model powers and exponents.

#### Materials

centimeter cubes  
grid paper

Students use centimeter cubes to model powers and exponents. On grid paper, they sketch the top and side view of each model.

#### Answers

1. top



side



2. top

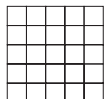

side

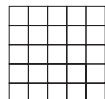

3. top

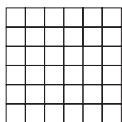

side



### Using Overhead Manipulatives

#### Variables and Expressions

(pp. 32–33 of this booklet)

**Use With** Lesson 1-4.

**Objective** Use cups and counters to model algebraic expressions.

#### Materials

counters\*  
cups\*  
integer mat transparency\*

\* = available in Overhead Manipulative Resources Kit

- Students use cups and counters to model and solve algebraic expressions.
- An Extension activity asks students to model and solve an algebraic expression using different values for the variable.

#### Answers

Answers appear on the teacher demonstration instructions on pages 32–33.



### Hands-On Lab Recording Sheet

#### Exploring Sequences

(p. 34 of this booklet)

**Use With** Lesson 1-7b. This corresponds to the activity on page 37 in the Student Edition.

**Objective** Explore patterns in sequences using paper folding.

#### Materials

calculator  
piece of paper  
colored pencils

A table is provided for students to record their data. Space is also given for students to write and explain their answers.

#### Answers

See Teacher Wraparound Edition p. 37.



# Mini-Project

(Use with Lesson 1-2)

## Modeling Powers and Exponents

### Materials

centimeter cubes, grid paper

You can build a square or a cube using centimeter cubes.  $3^2$  is a three-by-three square and is 1 centimeter cube high. You need 9 centimeter cubes to build  $3^2$ .

The top view of  $3^2$  is shown at the left below. The side view of  $3^2$  is shown at the right below.

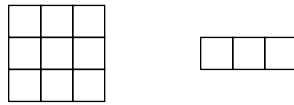

You need 64 centimeter cubes to build  $4^3$ . The top view is shown at the left below. The side view is shown at the right below.

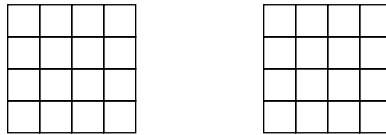

**Use centimeter cubes to build each square or cube. On grid paper, sketch the top view and the side view.**

1.  $2^3$

top view

side view

2.  $5^3$

top view

side view

3.  $6^2$

top view

side view



# Using Overhead Manipulatives

(Use with Lesson 1-4)

## Variables and Expressions

**Objective** Use cups and counters to model algebraic expressions.

**Materials**

- counters\*
- cups\*
- integer mat transparency\*

\* = available in Overhead Manipulative Resources Kit

### Teacher Demonstration

- Tell students that the phrase *the sum of two and some number* is an algebraic expression. The number 2 in this phrase is a **constant**, a number that you know, and “some number” is an **unknown value**. The phrase can be represented by a cup for the unknown value and 2 counters for the number 2. Place a cup and 2 counters on the integer mat.

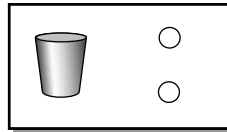

- Place 6 counters in the cup. The cup now has a value of 6. Remove the counters from the cup and count all the counters. There are a total of 8 counters. Thus, the expression has a value of 8.

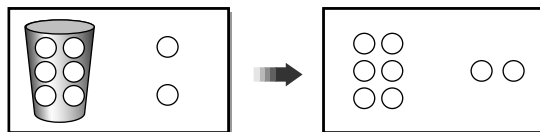

- Ask students what the value of the expression would be if 4 counters were placed in the cup and if no counters were placed in the cup. Model the correct answers if necessary. **(6, 2)**
- Clear the mat.

- Tell students that the phrase *three times some number* is also an algebraic expression. Ask students how this phrase can be expressed mathematically. **(Use three cups.)** Stress that the same number of counters must be placed in each cup. Place 2 counters in each cup. Empty the cups and count all the counters. There are 6. The expression has a value of 6.

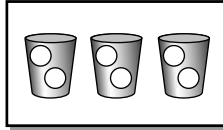

- Ask students what the value of the expression is if 1 counter is placed in each cup; if 5 counters are placed in each cup. Demonstrate the correct answers if necessary. **(3, 15)**

**Have students complete Exercises 1–5.**

**Model each phrase with cups and counters. Then put four counters in each cup. How many counters are there in all? Record your answers by drawing pictures of your models.**

1. the sum of 3 and a number **(7)**
2. 3 times a number **(12)**
3. 5 more than a number **(9)**
4. twice a number plus 1 **(9)**
5. Write a sentence to describe what the cup represents.

**(Sample answer: The cup represents the variable or unknown quantity.)**

**Extension**

Model the phrase *four more than three times some number* as a third example. Use 3 cups to represent “three times some number”, and use 4 counters to represent the number 4. Place 5 counters in each cup. Empty the cups and count all the counters. There are 19. The expression has a value of 19. Ask students what the value of the expression is if 1 counter is placed in each cup; if 3 counters are in each cup. **(7, 13)**



# Hands-On Lab Recording Sheet

(Use with the activity on page 37 in Lesson 1-7b of the Student Edition)

## Exploring Sequences

### Materials

calculator, piece of paper, colored pencils

### Investigate

Work with a partner. Complete the table.

Number of Folds	Layers of Paper	Fraction of Paper Not Shaded
1	2	$\frac{1}{2}$
2	4	$\frac{1}{4}$
3	8	
4		
5		

### Writing Math

Work with a partner.

- Examine** the sequence of numbers in the “Layers” column of your table. Is the sequence arithmetic or geometric? Then write a rule to find the next three terms.
- Examine** the sequence of numbers in the “Fraction” column of your table. Is the sequence arithmetic or geometric? Then write a rule to find the next three terms. (*Hint:* Write each fraction as a decimal.)
- Assume you could continue the paper-folding process indefinitely. Suppose your unfolded piece of paper is 0.002 inch thick. Add a column to your table and find the thickness of the paper for the first five folds.
- How many folds would it take until the paper is as tall as you?
- Explain** the relationship between the number of layers and the fraction of the shaded region.



# Statistics: Analyzing Data

## Teaching Notes and Overview



### Mini-Project

#### Story Graph

(p. 37 of this booklet)

**Use With** Lesson 2-2.

**Objective** Interpret and describe a line graph.

#### Materials

none

Students interpret a given line graph and describe it by writing a story that fits the data shown.

#### Sample Answer

I left my house at 4:15 P.M. to go to the store for Mom. She asked me to buy some milk and tortillas for dinner. I walked 5 minutes before meeting my friend, Lina. We talked for 5 minutes. Then I continued walking to the store at the same pace I had been walking. I arrived at the store 10 minutes later. It took me 10 minutes to buy milk and tortillas. On the way home, I walked a little faster because Mom wanted the groceries by 5 P.M. I made it home in 10 minutes. I was early.



### Hands-On Lab Recording Sheet

#### Are You Average?

(p. 38 of this booklet)

**Use With** Lesson 2-4b. This corresponds to the activity on page 73 in the Student Edition.

**Objective** Use mean, median, mode, and range to describe a set of data.

#### Materials

markers  
ruler

Students work in groups to collect data, create a frequency table, and create an appropriate graph to display their data. Students are asked to explain why they chose the type of graph they did for their data.

#### Answers

See Teacher Wraparound Edition p. 73.



### Using Overhead Manipulatives

#### Quartiles

(pp. 39–40 of this booklet)

**Use With** Lesson 2-6.

**Objective** Graph quartiles and determine the interquartile range.

#### Materials

blank transparencies, prepared as described below  
transparency pens\*

\* = available in Overhead Manipulative Resources Kit

- Students find and graph the upper and lower quartiles and the interquartile range of a given set of data.
- An Extension activity asks students to find and graph the upper and lower quartiles and the interquartile range of a second set of data, then compare the two sets of data.

#### Answers

Answers appear on the teacher demonstration instructions on pages 39–40.



## **Using Overhead Manipulatives**

### **How Much is a Handful?**

(p. 41 of this booklet)

**Use With** Lesson 2-8.

**Objective** Use data to make predictions.

#### **Materials**

transparency pens\*

11 blank transparencies

40 counters\*

\* = available in Overhead Manipulative Resources Kit

- Students collect data by tracing their hands on a transparency and counting the number of counters it takes to cover the shape.
- Based on the data they have gathered, students then make predictions about the number of counters needed to cover the hands of other students and adults.

#### **Answers**

Answers appear on the teacher demonstration instructions on page 41.



# Mini-Project

(Use with Lesson 2-2)

## Story Graph

Make up a story to fit this graph. The graph describes the distance you are from your house with respect to time. The story should include where you begin, end, and stop along the way. Make sure you also mention how long it takes you to travel from place to place and how long you stay at each place.

To help you understand what is happening, you may want to act out the graph. Use seconds instead of minutes and ignore the distance scale.

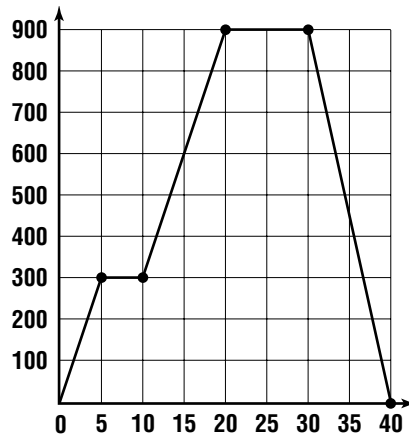

---

---

---

---

---

---

---

---

---

---

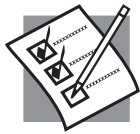

# Hands-On Lab Recording Sheet

(Use with the activity on page 73 in Lesson 2-4b of the Student Edition)

## Are You Average?

### Materials

markers, ruler

### Investigate

*Work in groups of four. Use the space provided below for your frequency table.*

- Find the mean, median, mode, and range of the data for each question if appropriate. Which measure best describes each set of data? Justify your answer.
- Create appropriate graphs to display your data from all ten questions. Each group will present their graphs with a description of what the “average” student in your classroom is like.

### Writing Math

1. **Explain** why results may vary if you survey another class in your school.
2. **Explain** why your group selected the graph that you did to display your data. Could you have used another type of graph? Explain.
3. The word *bias* means to influence. **Describe** any factors that could have unfairly influenced the responses given by your classmates. Is there a way to limit bias in a survey?



# Using Overhead Manipulatives

(Use with Lesson 2-6)

## Quartiles

**Objective** Graph quartiles and determine the interquartile range.

**Materials**

- blank transparencies, prepared as described below
- transparency pens\*

\* = available in Overhead Manipulative Resources Kit

### Teacher Demonstration

- Prepare blank transparencies with copies of the tables shown below and in the Extension.
- Show students the first table. Tell them that the table shows various suspension bridges in the United States and the length of their main span.
- Tell students that in a large set of data, it is helpful to separate the data into four equal parts called *quartiles*. Tell them you are going to find and graph the quartiles for these data.
- Ask students to list the data in order from least to greatest. **(533, 549, 564, 610, 655, 655, 701, 704, 853, 1,067, 1,158, 1,280, 1,298)** Write the data in order below the table.
- Ask students how to find the median of the data. **(Find the data number that is in the middle when the data are arranged in order from least to greatest.)** Then have them find the median. **(701)** Circle the median and point out that it separates the data into two equal groups.
- On the list of data, place an arrow between 564 and 610 and between 1,158 and 1,067 as shown. Find their means and tell students that these numbers represent the median of the lower half, the *lower quartile*, and the median of the upper half, the *upper quartile*, of the data.

Name, Location	Length of Main Span (m)
Ambassador International, Detroit	564
Benjamin Franklin, Philadelphia	533
Bronx-Whitestone, New York City	701
Delaware Memorial, Wilmington, Delaware	655
George Washington, New York City	1,067
Golden Gate, San Francisco	1,280
Mackinac Straits, Michigan	1,158
Tacoma Narrows II, Tacoma, Washington	853
San Francisco-Oakland Bay, San Francisco	704
Seaway Skyway, Ogdensburg, New York	655
Throgs Neck, New York City	549
Verrazano-Narrows, New York	1,298
Walt Whitman, Philadelphia	610

Source: Federal Highway Administration

533 549 564 610 655 655 701 704 853 1,067 1,158 1,280 1,298

$$\begin{array}{ccc} \uparrow & \uparrow & \uparrow \\ \frac{564 + 610}{2} = 587 & \text{median} & \frac{1,067 + 1,158}{2} = 1,112.5 \end{array}$$

- Point out that half of the data numbers, the middle half, lie between the lower and upper quartiles, 587 and 1,112.5. Tell them that the range of the middle half of the data is called the *interquartile range*. Ask students to find the interquartile range of these data. **(525.5)**
- Below the data, draw a number line from 500 to 1,300. Graph the median of the data above the number line. Then show students as you graph the least value, the greatest value, the upper quartile, and the lower quartile above the number line.

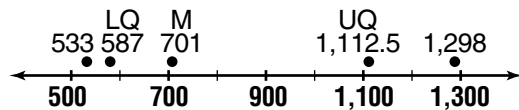

- Point out that the numbers graphed separate the data into four groups. Ask how many of the numbers in the data set fall in each group. **(3)**

**Extension**

Show students the table below. Tell them that the table shows various suspension bridges internationally and the lengths of their main spans.

Have students find the median, upper quartile, lower quartile, least value, and greatest value for the data. **(1,043.5; 1,377; 988; 668; 1,990)** Then have them graph those values. Finally, compare the number lines for the two sets of data. Ask students what conclusions they can make from the data. **(Sample answer: The middle half of the data for international bridges is less spread out. International bridges generally have longer spans than those in the United States.)**

Name, Location	Length of Main Span (m)
Akashi Kaiko, Japan	1,990
First Bosphorus, Istanbul, Turkey	1,074
Forth Road, Queensferry, Scotland	1,006
Humber, Hull, Britain	1,410
Kita Bisan-Seto, Japan	990
Minami Bisan-Seto, Japan	1,100
Ohnaruto, Japan	876
Pierre Laporte, Quebec, Canada	668
Ponte 25 de Abril, Lisbon, Portugal	1,013
Second Bosphorus, Istanbul, Turkey	1,090
Severn, Beachley, England	988
Shimotsui Straits, Japan	940
Storebelt, Denmark	1,624
Tsing Ma Bridge, Hong Kong	1,377

Source: Federal Highway Administration



# Using Overhead Manipulatives

(Use with Lesson 2-8)

## How Much is a Handful?

**Objective** Use data to make predictions.

**Materials**

- transparency pens\*
- 11 blank transparencies
- 40 counters\*

\* = available in Overhead Manipulative Resources Kit

### Teacher Demonstration

- Ask four volunteers to trace the outline of their hand on a transparency.
- Place one of the outlines on the overhead and cover the shape with counters. Count the counters used and record on a fifth transparency. Repeat the procedure for each of the three outlines.
- Find the mode, median, and mean of the data. Ask the students which of these “averages” is most representative of the data.
- Discuss the most effective way to present the data. Alternatives include the frequency table, bar graph, line plot, or stem-and-leaf plot. Use the sixth blank transparency to prepare the data in the agreed-upon manner.
- Ask students to predict how many counters would be needed to cover a hand outline for a student in the same grade but not in the class.
- Have students randomly choose four students who are not in your class and trace the outline of their hands on a transparency. Record the counters needed to cover the shape. Have students compare the number of counters with their prediction.
- Trace your own hand on a transparency and find the number of counters needed to cover the shape. Ask how this number compares with the other data. **(In most cases, it will be greater than the average of the student data.)**
- Ask whether you could use the information about the teacher’s hand to predict about how many counters would cover other adults’ hands. **(Data from one adult would not be sufficient to predict for other adults.)**

# Algebra: Integers

## Teaching Notes and Overview



### Mini-Project

#### Coordinate Plane Puzzle

(p. 44 of this booklet)

**Use With** Lesson 3-3.

**Objective** Locate points for ordered pairs on a coordinate plane

#### Materials

none

Given ordered pairs, students locate the appropriate points labeled on a coordinate plane. Students solve the puzzle by matching each point with the correct ordered pair.

#### Answer

WE ARE COORDINATED!



### Hands-On Lab Recording Sheet

#### Adding Integers

(p. 45 of this booklet)

**Use With** Lesson 3-4a. This corresponds to the activity on pages 118–119 in the Student Edition.

**Objective** Use counters to model the addition of integers.

#### Materials

counters  
integer mat

Students use counters to add integers. Space is provided for students to explain their work. They will write their own addition sentences and draw conclusions on how to add integers.

#### Answers

See Teacher Wraparound Edition  
pp. 118–119.



### Hands-On Lab Recording Sheet

#### Subtracting Integers

(p. 46 of this booklet)

**Use With** Lesson 3-5a. This corresponds to the activity on pages 126–127 in the Student Edition.

**Objective** Use counters to model the subtraction of integers.

#### Materials

counters  
integer mat

Students use counters to subtract integers. Space is provided for students to explain their work. They will write their own subtraction sentences and draw conclusions on how to subtract integers.

#### Answers

See Teacher Wraparound Edition  
pp. 126–127.





## **Using Overhead Manipulatives**

### **Multiplying Integers**

(pp. 47–48 of this booklet)

**Use With** Lesson 3-6.

**Objective** Multiply integers by using models.

#### **Materials**

counters\*

integer mat transparency\*

transparency pen\*

\* = available in Overhead Manipulative Resources Kit

This demonstration contains two activities.

- Demonstration 1 shows how to model the multiplication of two positive integers or a positive and a negative integer.
- Demonstration 2 shows how to model the multiplication of two negative integers.
- Extension questions ask students to model and solve integer multiplication problems independently.

#### **Answers**

Answers appear on the teacher demonstration instructions on pages 47–48.



# Mini-Project

(Use with Lesson 3-3)

## Coordinate Plane Puzzle

Use the coordinate plane to find the point for each ordered pair below. Then write the letter for each point under its ordered pair at the bottom of the page. When you have filled in all the letters, you will know what two points on a grid said to each other.

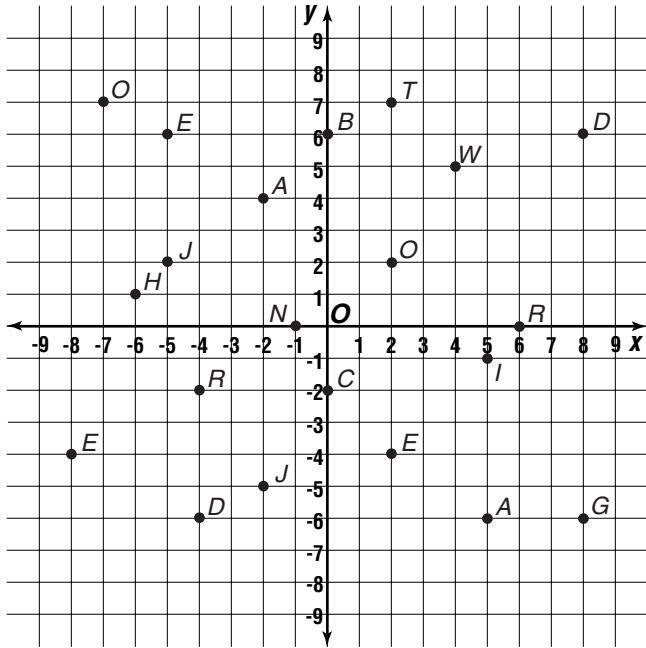

(4, 5)   (-5, 6)                      (5, -6)   (-4, -2)   (2, -4)

\_\_\_\_\_                      \_\_\_\_\_                      \_\_\_\_\_  
 (0, -2)   (2, 2)   (-7, 7)   (6, 0)   (-4, -6)   (5, -1)   (-1, 0)   (-2, 4)   (2, 7)   (-8, -4)   (8, 6)



# Hands-On Lab Recording Sheet

(Use with the activity on pages 118–119 in Lesson 3-4a of the Student Edition)

## Adding Integers

### Materials

counters, integer mat

### Your Turn

Use counters to find each sum.

a.  $5 + 6$

b.  $-3 + (-5)$

c.  $-5 + (-4)$

d.  $7 + 3$

e.  $-2 + (-5)$

f.  $-8 + (-6)$

g.  $-6 + 5$

h.  $3 + (-6)$

i.  $-2 + 7$

j.  $8 + (-3)$

k.  $-9 + 1$

l.  $-4 + 10$

### Writing Math

1. **Write** two addition sentences where the sum is positive. In each sentence, one addend should be positive and the other negative.
2. **Write** two addition sentences where the sum is negative. In each sentence, one addend should be positive and the other negative.
3. **MAKE A CONJECTURE** Write a rule that will help you determine the sign when finding the sum of integers.

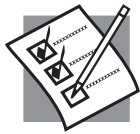

NAME \_\_\_\_\_ DATE \_\_\_\_\_ PERIOD \_\_\_\_\_

# Hands-On Lab Recording Sheet

(Use with the activity on pages 126–127 in Lesson 3-5a of the Student Edition)

## Subtracting Integers

### Materials

counters, integer mat

### Your Turn

Use counters to find each difference.

a.  $7 - 6$

b.  $5 - (-3)$

c.  $6 - (-3)$

d.  $5 - 8$

e.  $-6 - (-3)$

f.  $-7 - 3$

g.  $-5 - (-7)$

### Writing Math

*Work with a partner.*

1. **Write** two subtraction sentences where the difference is positive. Make sure you use a combination of positive and negative integers.
2. **Write** two subtraction sentences where the difference is negative. Make sure you use a combination of positive and negative integers.
3. **MAKE A CONJECTURE** Write a rule that will help you determine the sign of the difference of two integers.



# Using Overhead Manipulatives

(Use with Lesson 3-6)

## Multiplying Integers

**Objective** Multiply integers by using models.

**Materials**

counters\*

integer mat transparency\*

transparency pen\*

\* = available in Overhead Manipulative Resources Kit

### Teacher Demonstration for Activity 1

- Review with students the meaning of the two colors of counters. If necessary, mark the yellow counters to show they are “positive” counters and the red counters to show they are “negative” counters.
- Remind students that  $3 \times 2$  means *three sets of two items*. Tell students that modeling  $3 \times 2$  means to place 3 sets of 2 positive counters on the mat. Model  $3 \times 2$ . Ask students to complete:  $3 \times 2 = \underline{\quad? \quad}$ . **(6)**



- Place 3 sets of 2 negative counters on the mat. Ask students to state the multiplication sentence that has been modeled. **( $3 \times (-2) = -6$ )**



### Teacher Demonstration for Activity 2

- Clear the mat. Write  $-3 \times 2$  at the base of the mat. Tell students that since  $-3$  is the opposite of 3,  $-3 \times 2$  means to *remove* 3 sets of 2 positive counters.
- Place 6 zero pairs on the mat. Ask students to state the value of the mat. **(0)**

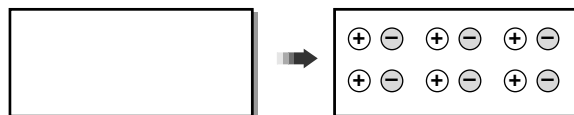

- Remove 3 sets of 2 positive counters. Ask students to state the value of the mat. **(-6)**

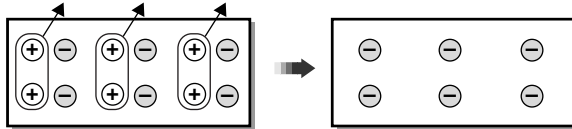

- Ask students to complete the sentence  $-3 \times 2 = \underline{\quad? \quad}$ . **(-6)**
- Clear the mat. Write  $-3 \times (-2)$  at the base of the mat. Ask students how many zero pairs must be placed on the mat to model  $-3 \times (-2)$ . **(6)**
- Place 6 zero pairs on the mat. Ask students whether positive or negative counters should be removed to model  $-3 \times (-2)$ . **(negative)** Remove 3 sets of 2 red counter. Ask students the value of the mat. **(6)**

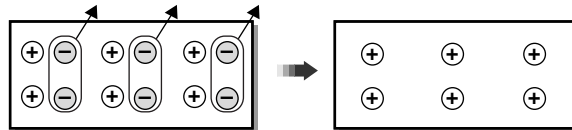

- Ask students to complete the sentence  $-3 \times (-2) = \underline{\quad? \quad}$ . **(6)**

### **Have students complete Exercises 1-7.**

Use counters to find each product. Use your result to write a multiplication sentence.

- $2 \times 3$  ( $2 \times 3 = 6$ )
- $2 \times (-4)$  ( $2 \times (-4) = -8$ )
- $-2 \times (-3)$  ( $-2 \times (-3) = 6$ )
- $3 \times (-4)$  ( $3 \times (-4) = -12$ )
- $4 \times 0$  ( $4 \times 0 = 0$ )
- $-1 \times (-5)$  ( $-1 \times (-5) = 5$ )
- Find  $9 \times (-3)$  without using models. **(-27)**

### **Extension**

Ask students to model each multiplication and then write a multiplication sentence.

- $4 \times 3$  ( $4 \times 3 = 12$ )  
 $-4 \times (-3)$  ( $-4 \times (-3) = 12$ )  
 $4 \times (-3)$  ( $4 \times (-3) = -12$ )  
 $-4 \times 3$  ( $-4 \times 3 = -12$ )

# Algebra: Linear Equations and Functions

## Teaching Notes and Overview



### Hands-On Lab Recording Sheet

Solving Equations Using Models  
(p. 51 of this booklet)

**Use With** Lesson 4-2a. This corresponds to the activity on pages 154–155 in the Student Edition.

**Objective** Solve equations using algebra tiles.

#### Materials

cups and counters  
equation mat

Students use algebra tiles to model and solve addition and subtraction equations. Space is provided for students to explain their answers and draw conclusions.

#### Answers

See Teacher Wraparound Edition pp. 154–155.



### Mini-Project

#### Solving Multiplication Equations

(p. 52 of this booklet)

**Use With** Lesson 4-3.

**Objective** Model and solve multiplication equations.

#### Materials

cups and counters  
equation mat

Students use cups and counters to model and solve multiplication equations. Space is provided for students to sketch their models and write their answers.

#### Answers

1–2. Answers will vary.

3. 3

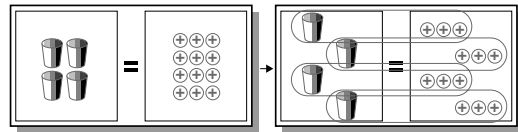

4.  $-7$

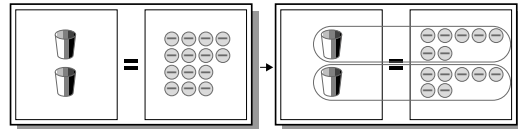

5.  $-5$

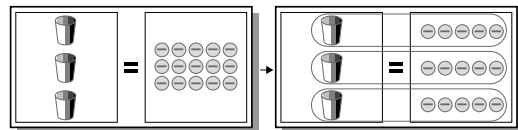

6.  $-2$



### Using Overhead Manipulatives

Solving Two-Step Equations  
(pp. 53–54 of this booklet)

**Use With** Lesson 4-4.

**Objective** Solve two-step equations by using models.

#### Materials

cups\*  
counters\*  
equation mat transparency\*

\* = available in Overhead Manipulative Resources Kit

- Students solve a two-step equation as it is modeled on the overhead.
- An Extension activity asks students to explain in writing how the modeling equations uses the work backward strategy.

#### Answers

Answers appear on the teacher demonstration instructions on pages 53–54.



## **Hands-On Lab Recording Sheet**

**Functions and Graphs**  
(p. 55 of this booklet)

**Use With** Lesson 4-6a. This corresponds to the activity on page 176 in the Student Edition.

**Objective** Graph a function on a scatter plot.

### **Materials**

stop watch  
uncooked spaghetti

Students will perform the “wave” with various numbers of students in the class. They are provided with a graph on which they can record their data. They use the graph to find a pattern, make predictions, and explain their reasoning.

### **Answers**

See Teacher Wraparound Edition p. 176.



## **Using Overhead Manipulatives**

**A Function of Time**

(pp. 56–57 of this booklet)

**Use With** Lesson 4-6.

**Objective** Use a function rule to find the output of a function.

### **Materials**

coordinate grid transparency\*  
transparency pen\*  
transparency prepared with the two tables  
shown in the demonstration

\* = available in Overhead Manipulative Resources Kit

- Students use given data for the input values and the function rule to find the output values of a function.
- Students then use the graph of the function to make predictions.
- An Extension activity asks students to give examples of other functions of time.

### **Answers**

Answers appear on the teacher demonstration instructions on pages 56–57.





# Hands-On Lab Recording Sheet

(Use with the activity on pages 154–155 in Lesson 4-2a of the Student Edition)

## Solving Equations Using Models

### Materials

cups and counters, equation mat

### Investigate

The scale at the right is balanced, and the bag contains a certain number of blocks.

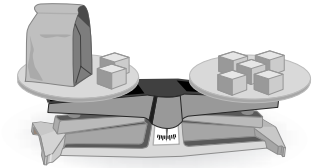

1. Suppose you cannot look in the bag. How can you find the number of blocks in the bag?
2. In what way is a balanced scale like an equation?
3. What does it mean to solve *an equation*?

### Your Turn

Solve each equation using models.

a.  $x + 1 = 3$

b.  $x + 3 = 7$

c.  $x + 4 = 4$

d.  $x + 3 = -2$

e.  $x + 4 = 1$

f.  $-2 = x + 1$

g.  $x - 3 = -2$

h.  $x - 1 = -3$

i.  $4 = x - 2$

### Writing Math

1. How is solving an equation similar to keeping a scale in balance.
2. For any equation, how can you determine how many counters to add or subtract from each side?
3. **Identify** the property of numbers that is illustrated by a zero pair.
4. **Identify** the property of numbers that allows you to add or subtract zero without changing the value of a number.
5. **MAKE A CONJECTURE** Write a rule that you can use to solve an equation like  $x + 3 = 2$  without using models.



# Mini-Project

(Use with Lesson 4-3)

## Solving Multiplication Equations

Write the equation modeled by the cups and counters.

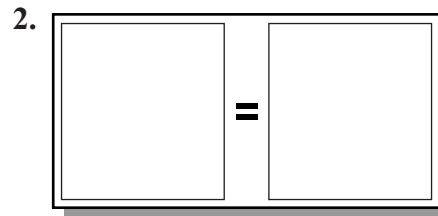
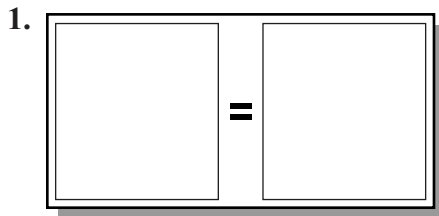

\_\_\_\_\_

\_\_\_\_\_

Solve each equation using cups and counters. Sketch the arrangement in the boxes.

3.  $4x = 12$

$x = \underline{\hspace{2cm}}$

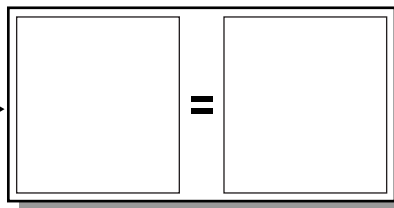
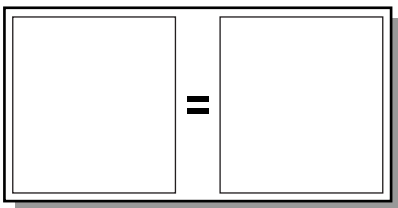

4.  $2x = -14$

$x = \underline{\hspace{2cm}}$

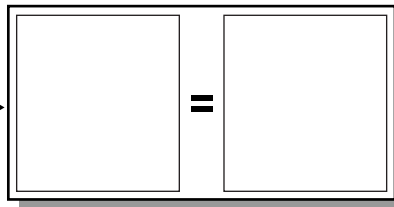
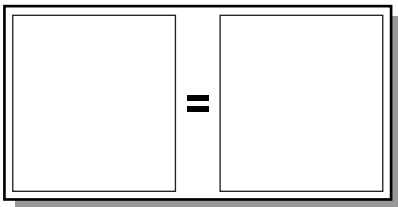

5.  $3x = -15$

$x = \underline{\hspace{2cm}}$

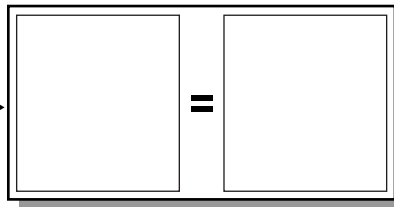
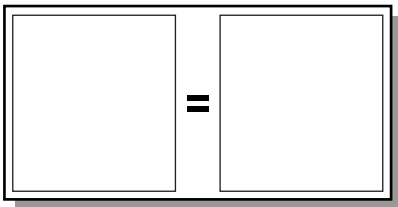

Solve without using models.

6.  $5x = -10$

$x = \underline{\hspace{2cm}}$



# Using Overhead Manipulatives

(Use with Lesson 4-4)

## Solving Two-Step Equations

**Objective** Solve two-step equations by using models.

**Materials**

- cups\*
- counters\*
- equation mat transparency\*

\* = available in Overhead Manipulative Resources Kit

**Teacher Demonstration**

- Remind students that, in modeling, red counters represent negative integers, yellow counters represent positive integers, and a cup represents  $x$ .
- Review the use of zero pairs. Ask students what happens to an equation if a zero pair is added to or subtracted from a side. **(An equivalent equation results.)**
- Place 3 cups and 2 yellow counters on the left side of an equation mat and place 4 red counters on the right side. Ask students what equation is modeled. **( $3x + 2 = -4$ )**

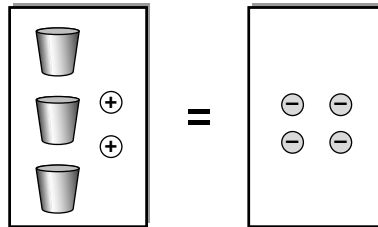

- Add 2 red counters to each side of the equation mat. Point out that you do this to create zero pairs on the left side. Remove the zero pairs. Ask students why you can remove the zero pairs. **(Their value is 0.)**

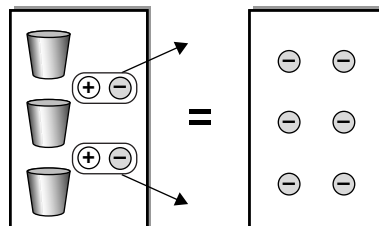

- Ask students what equation is represented on the mat. ( $3x = -6$ )
- Pair up an equal number of counters with each cup.

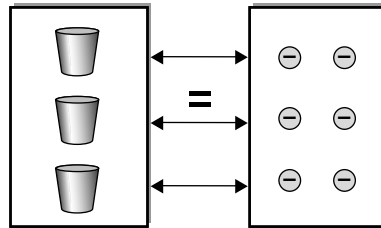

- Ask students what the solution of the equation  $3x + 2 = -4$  is. ( $-2$ )

**Extension**

Have students write a few sentences explaining how the modeling demonstrated in this lab uses the work backward strategy presented in Lesson 4-4a. (**Sample answer: Modeling the solution to two-step equations uses the reverse of the order of operations.**)



# Hands-On Lab Recording Sheet

(Use with the activity on page 176 in Lesson 4-6a of the Student Edition)

## Functions and Graphs

### Materials

stop watch, uncooked spaghetti

### Writing Math

Work with a partner.

- Graph** the ordered pairs (number of students, time) on the coordinate grid at the right.
- Describe** how the points appear on your graph.

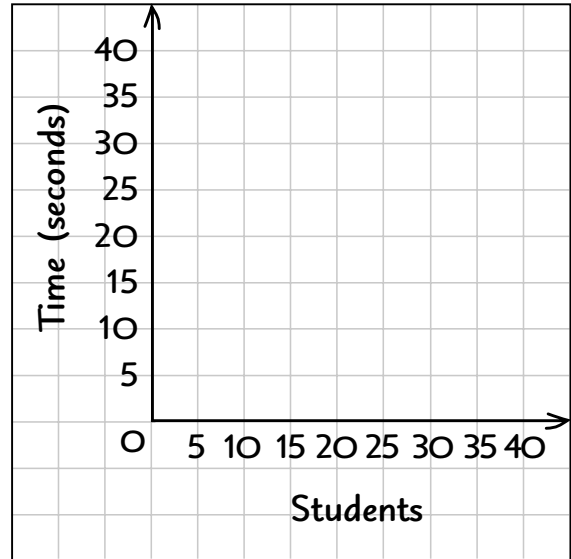

- Place one piece of uncooked spaghetti on your graph so that it covers as many of the points as possible. **Predict** how long it would take 30 students to complete the “wave.” Make a prediction for 50 students.

- Find a pattern** in the data and use the pattern to predict how long it would take the students in your school to complete the “wave.” Explain your reasoning.

- A *function* describes the relationship between two quantities. In a function, one quantity *depends* on the other. **Complete the sentence:** The time it takes to do the “wave” depends on     ?    .



# Using Overhead Manipulatives

(Use with Lesson 4-6)

## A Function of Time

**Objective** Use a function rule to find the output of a function.

**Materials**

- coordinate grid transparency\*
- transparency pen\*
- transparency prepared with the two tables shown below

\* = available in Overhead Manipulative Resources Kit

**Teacher Demonstration**

- Tell students that a certain secretary can type an average of 55 words per minute. Ask students to use this information to complete the table.

Minutes	Minutes $\times$ Average Number of Words per Minute	Total Words
1	$1 \times ?$	(55)
2	$2 \times ?$	(110)
3	$3 \times ?$	(165)
4	$4 \times ?$	(220)
5	$5 \times ?$	(275)

- Tell students that in this example the minutes are called the *input* values, the total words processed are called *output* values, and the middle column contains the *function rule*.
- Graph the ordered pairs (minutes, words) on the coordinate grid transparency. Draw a line passing through the points.
- Ask students how they could use the graph to estimate the number of words typed in 8 minutes. **(Extend the line; 440 words.)**
- Say, “Let  $t$  be the time in minutes. What is the expression for the total number of words typed in  $t$  minutes?” **( $55t$ )**

- Tell students that another secretary can type an average of 70 words per minute. Repeat the activity using the information below.

Minutes	Minutes $\times$ Average Number of Words per Minute	Total Words
1	$1 \times ?$	(70)
2	$2 \times ?$	(140)
3	$3 \times ?$	(210)
4	$4 \times ?$	(280)
5	$5 \times ?$	(350)

**Extension**

Have students give examples of other functions of time. **(Sample answer: revolutions per minute)**

# Fractions, Decimals, and Percents

## Teaching Notes and Overview



### Hands-On Lab Recording Sheet

#### Exploring Factors

(p. 59 of this booklet)

**Use With** Lesson 5-1a. This corresponds to the activity on page 196 in the Student Edition.

**Objective** Discover factors of whole numbers.

#### Materials

15 index cards cut in half  
markers

Students work as a class to determine factors of whole numbers by identifying patterns. Space is provided for students to explain their answers and make predictions.

#### Answers

See Teacher Wraparound Edition p. 196.



### Using Overhead Manipulatives

#### Percent

(p. 60 of this booklet)

**Use With** Lesson 5-5.

**Objective** Illustrate the meaning of percent using models.

#### Materials

centimeter grid transparency\*  
transparency pens\*

\* = available in Overhead Manipulative Resources Kit

- Using a model on the centimeter grid transparency, students write a ratio of the number of shaded squares to the total number of squares.
- Students make conclusions about the meaning of percent based on the model.

#### Answers

Answers appear on the teacher demonstration instructions on page 60.





# Hands-On Lab Recording Sheet

(Use with the activity on page 196 in Lesson 5-1a of the Student Edition)

## Exploring Factors

### Materials

15 index cards cut in half, markers

### Writing Math

*Work as a class.*

1. How many students are standing at the end of the activity? Which cards are they holding?
2. **LOOK FOR A PATTERN** Suppose there were 100 students holding index cards. Extend the pattern in Exercise 1 to predict the numbers that would be held by students standing at the end of the activity.
3. **Explain** the relationship between the numbers on the front and the back of the cards.
4. Separate the cards into two groups: one group with exactly two numbers on the back of the card and one group with more than two numbers. **Describe** any special characteristics of each group.



# Using Overhead Manipulatives

(Use with Lesson 5-5)

## Percent

**Objective** Illustrate the meaning of percent using models.

**Materials**

- centimeter grid transparency\*
- transparency pens\*

\* = available in Overhead Manipulative Resources Kit

### Teacher Demonstration

- On the centimeter grid transparency, outline a 10-by-10 square. Using a different colored pen, shade 25 of the squares as shown.

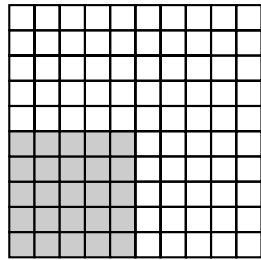

- Ask, “How many small squares are in the model?” **(100)**
- Ask, “How many small squares are shaded?” **(25)**
- Ask students to write a ratio of shaded squares to squares in the model.  $\left(\frac{25}{100}\right)$
- Tell students that the model represents 25 percent. Ask them to make a conjecture about the meaning of the word *percent*. **(Sample answer: Percent is a ratio comparing a number to 100.)**

# Applying Fractions

## Teaching Notes and Overview



### Using Overhead Manipulatives

#### Multiplying Fractions and Mixed Numbers

(pp. 62–63 of this booklet)

**Use With** Lesson 6-4.

**Objective** Use models to multiply fractions and mixed numbers.

#### Materials

blank transparency

ruler\*

transparency pens\*

\* = available in Overhead Manipulative Resources Kit

This demonstration contains three activities.

- Demonstration 1 shows the multiplication of two fractions.
- Demonstration 2 shows the multiplication of a whole number and a fraction.
- Demonstration 3 shows the multiplication of a fraction and a mixed number.
- Students are asked to find products of fractions and mixed numbers independently.
- An Extension activity asks students to model the multiplication of two mixed numbers.

#### Answers

Answers appear on the teacher demonstration instructions on pages 62–63.



### Mini-Project

#### Perimeter

(p. 64 of this booklet)

**Use With** Lesson 6-8.

**Objective** Measure the sides of figures and find the perimeter.

#### Materials

ruler

Given several figures, students measure the sides, label them, and then find the perimeter.

#### Answers

$$1. P = 1\frac{1}{4} + 1\frac{1}{4} + 1\frac{1}{4} + 1\frac{1}{4} = 5 \text{ in.}$$

$$2. P = \frac{3}{4} + 1\frac{3}{8} + 2 + 1\frac{7}{8} = 6 \text{ in.}$$

$$3. P = 1\frac{1}{8} + 1\frac{1}{8} + 1\frac{7}{8} + 1\frac{1}{8} = 5\frac{1}{4} \text{ in.}$$

$$4. P = 1 + 1 + 1\frac{1}{4} = 3\frac{1}{4} \text{ in.}$$

$$5. P = 1\frac{1}{8} + \frac{5}{8} + 1 + 1\frac{1}{8} + 2\frac{3}{8} = 6\frac{1}{4} \text{ in.}$$

$$6. P = \frac{5}{8} + 1 + 1 + \frac{5}{8} + \frac{7}{8} + 1\frac{1}{4} + \frac{7}{8} = 6\frac{1}{4} \text{ in.}$$



### Hands-On Lab Recording Sheet

#### Circumference

(p. 65 of this booklet)

**Use With** Lesson 6-9a. This corresponds to the activity on page 274 in the Student Edition.

**Objective** Find a relationship between circumference and diameter.

#### Materials

ruler

measuring tape

circular objects

Students find the diameter and circumference of various circular objects and record their measurements in a table. A graph is provided for students to graph their data, find the slope of the line, and discover a relationship between circumference and diameter.

#### Answers

See Teacher Wraparound Edition p. 274.



# Using Overhead Manipulatives

(Use with Lesson 6-4)

## Multiplying Fractions and Mixed Numbers

**Objective** Use models to multiply fractions and mixed numbers.

**Materials**

- blank transparency
- ruler\*
- transparency pens\*

\* = available in Overhead Manipulative Resources Kit

### Teacher Demonstration for Activity 1

- Use the ruler and a black transparency pen to draw a square like the one shown. Divide the square vertically into halves and horizontally into fourths.
  - Tell students you are going to model  $\frac{1}{2} \times \frac{1}{4}$ .
  - Color one half of the square blue.
  - Color one fourth of the square red.
  - Count the small rectangles that are shaded both colors. Ask students what number is represented.
- $\left(\frac{1}{8}\right)$  Write  $\frac{1}{2} \times \frac{1}{4} = \frac{1}{8}$  below the model.

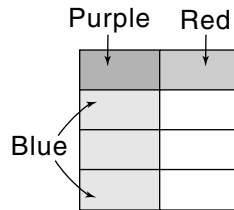
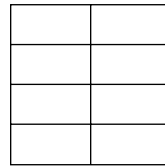

### Teacher Demonstration for Activity 2

- Use the ruler and a black transparency pen to draw 2 squares side-by-side. Divide them horizontally into fifths.
  - Tell students you are going to model  $2 \times \frac{3}{5}$ .
  - Color the 2 squares blue.
  - Color three-fifths of the squares red.
  - Count the small rectangles that are shaded both colors. Point out that 6 small rectangles are shaded and each has an area of  $\frac{1}{5}$  of a unit square. Ask students to add the areas.
- $\left(\frac{6}{5} \text{ or } 1\frac{1}{5}\right)$  Write  $2 \times \frac{3}{5} = \frac{6}{5}$  or  $1\frac{1}{5}$  below the model.

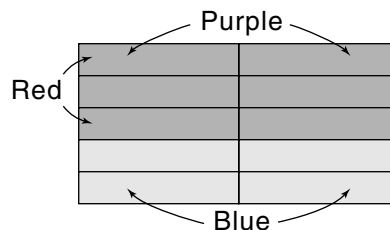
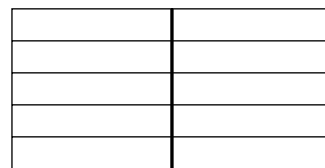

**Teacher Demonstration for Activity 3**

- Draw 2 unit squares side-by-side. Divide them vertically into fourths and horizontally into thirds.

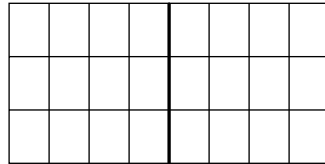

- Tell students you are going to model  $1\frac{1}{4} \times \frac{2}{3}$ .
- Color  $\frac{1}{4}$  of the squares blue.
- Color  $\frac{2}{3}$  of the squares red.
- Count the small rectangles that are shaded both colors. Point out that 10 of the small rectangles are shaded and each has an area of  $\frac{1}{12}$  of a unit square. Ask students to add the areas. ( $\frac{10}{12}$  or  $\frac{5}{6}$ ) Write  $1\frac{1}{4} \times \frac{2}{3} = \frac{10}{12}$  or  $\frac{5}{6}$  below the model.

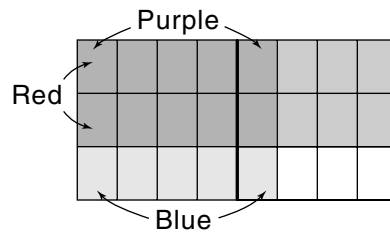
**Have students complete Exercises 1–7.**

Use area models to find each product.

1.  $\frac{1}{2} \times \frac{1}{3}$  ( $\frac{1}{6}$ )

2.  $\frac{2}{3} \times \frac{3}{4}$  ( $\frac{6}{12}$  or  $\frac{1}{2}$ )

3.  $3 \times \frac{1}{2}$  ( $\frac{3}{2}$  or  $1\frac{1}{2}$ )

4.  $2 \times \frac{3}{4}$  ( $\frac{6}{4}$  or  $1\frac{1}{2}$ )

5.  $1\frac{1}{3} \times \frac{1}{4}$  ( $\frac{4}{12}$  or  $\frac{1}{3}$ )

6.  $3\frac{1}{2} \times \frac{1}{2}$  ( $\frac{7}{4}$  or  $1\frac{3}{4}$ )

7. Find  $2\frac{1}{2} \times 1\frac{1}{3}$ . Use area models if necessary. ( $\frac{20}{6}$  or  $3\frac{1}{3}$ )

**Extension**

- Ask students how to suggest a model to show the product  $1\frac{1}{2} \times 1\frac{1}{3}$ . (**Make a drawing 2 squares across and 2 squares down. Shade  $1\frac{1}{2}$  of the squares vertically and  $1\frac{1}{3}$  horizontally.**) Draw the model. Have students find the product. ( $\frac{6}{3}$  or 2)

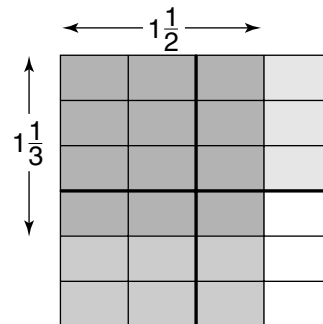



# Mini-Project

(Use with Lesson 6-8)

## Perimeter

Measure the segments in each figure to the nearest eighth of an inch. Label the segments with their measurements. Then find the perimeter of each figure.

1.

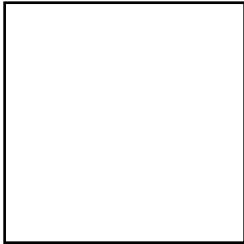

Perimeter = \_\_\_\_\_

2.

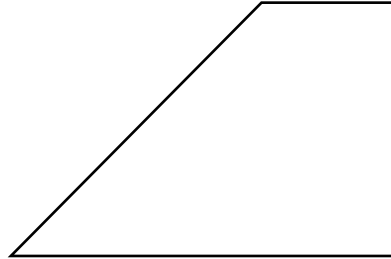

Perimeter = \_\_\_\_\_

3.

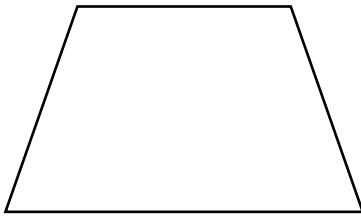

Perimeter = \_\_\_\_\_

4.

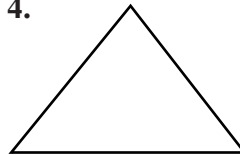

Perimeter = \_\_\_\_\_

5.

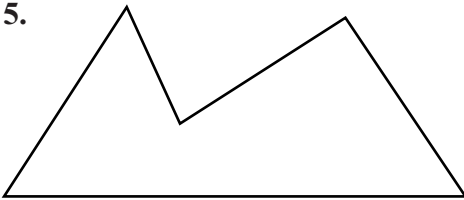

Perimeter = \_\_\_\_\_

6.

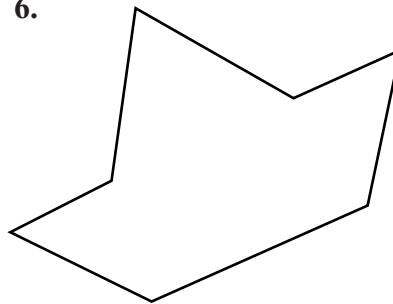

Perimeter = \_\_\_\_\_

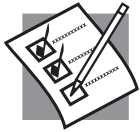

# Hands-On Lab Recording Sheet

(Use with the activity on page 274 in Lesson 6-9a of the Student Edition)

## Circumference

### Materials

ruler, measuring tape, circular objects

### Investigate

Work with a partner. Record your data in the table below.

Object	Diameter (cm)	Circumference (cm)	Circumference $\div$ Diameter

### Write About It

Work with a partner.

- For each object, divide the circumference by the diameter. Record the results in the table above. Round to the nearest tenth if necessary.
- What do you notice about the ratios?
- Graph** the ordered pair (diameter, circumference) on the coordinate plane for each object. What do you find?
- Select two points on the graph and find the slope between them. Select two different points and find the slope. What do you observe about the slopes?
- Use the graph to predict the circumference of a circular object that has a diameter of 18 centimeters.
- Write** a rule describing how you would find the circumference  $C$  of a circle if you know the diameter  $d$ .

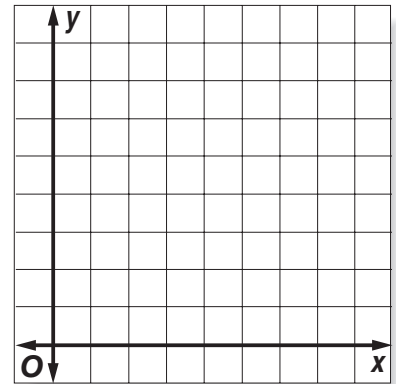

# Ratios and Proportions

## Teaching Notes and Overview



### Using Overhead Manipulatives

#### Equal Ratios

(pp. 68–69 of this booklet)

**Use With** Lesson 7-1.

**Objective** Explore the meaning of ratio and proportion.

#### Materials

counters\*  
blank transparency  
transparency pen\*

\* = available in Overhead Manipulative Resources Kit

- Students use counters to model ratios by finding equivalent fractions.
- An Extension activity asks students to work in pairs to find equivalent ratios.

#### Answers

Answers appear on the teacher demonstration instructions on pages 68-69.



### Hands-On Lab Recording Sheet

#### Rate of Change

(p. 70 of this booklet)

**Use With** Lesson 7-2b. This corresponds to the activity on page 296 in the Student Edition.

**Objective** Investigate rate of change.

#### Materials

square tiles

Students use tiles to build models and find the perimeter of each model. A table and coordinate plane is provided for students to record and graph their data. Students explore rate of change by finding the slope of the graph.

#### Answers

See Teacher Wraparound Edition p. 296.



### Hands-On Lab Recording Sheet

#### Wildlife Sampling

(p. 71 of this booklet)

**Use With** Lesson 7-3b. This corresponds to the activity on page 301 in the Student Edition.

**Objective** Use proportions to estimate.

#### Materials

small bowl  
dried beans  
paper cup  
markers

Using dried beans in a bowl to represent deer in a forest, students model the capture-recapture technique used to estimate animal populations. A table is provided for students to record their data, as well as space for them to explain their results.

#### Answers

See Teacher Wraparound Edition p. 301.





### **Mini-Project**

#### **Scale Drawings**

(p. 72 of this booklet)

**Use With** Lesson 7-4.

**Objective** Create a scale drawing.

#### **Materials**

ruler

Using the grid provided, students create a scale drawing of a room they would like to build. The drawing includes everything they wish to include in the room drawn to scale. Students must label their drawing and list the objects in the room and their actual size.

#### **Answers**

1. See students' work. Make sure drawings are the correct scale based on this information and the scale of the grid.
- 2–3. Answers will vary.



### **Hands-On Lab Recording Sheet**

#### **Using a Percent Model**

(p. 73 of this booklet)

**Use With** Lesson 7-8a. This corresponds to the activity on page 322 in the Student Edition.

**Objective** Use a percent model to find a part.

#### **Materials**

none

Grids are provided for students to draw models to find the percent of a number.

#### **Answers**

See Teacher Wraparound Edition p. 322.



# Using Overhead Manipulatives

(Use with Lesson 7-1)

## Equal Ratios

**Objective** Explore the meaning of ratio and proportion.

**Materials**

- counters\*
- blank transparency
- transparency pen\*

\* = available in Overhead Manipulative Resources Kit

### Teacher Demonstration

- Define *ratio* as the comparison of two numbers.
- Place 6 counters in a pile on a blank transparency. Label this pile X. Place 2 counters in a second pile. Label this pile Y. Divide pile X into two groups of 3 and pile Y into two groups of 1. Point out that for every three counters in pile X, there is one counter in pile Y. Tell students that piles X and Y have a ratio of 3 to 1.



- Clear the screen. Divide a blank transparency into 2 rows with 4 columns in each row. Label the sections as shown below. Place 3 counters in section A and 4 counters in section B. Ask students to name the ratio of the counters in A and B. **(3 to 4)**

A 	J 	L 	N 
B 	K 	M 	P 

- Place 6 counters in section J. Ask students how many counters must be placed in K so that the ratio of J to K is 3 to 4. **(8)**
- Place 12 counters in section M. Ask students how many counters must be placed in L so that the ratio of L to M is 3 to 4. **(9)**

- Place 15 counters in section N. Ask students how many counters must be placed in P so that the ratio of N to P is 3 to 4. **(20)**
- Ask students how they decided how many counters to place in sections K, L, and P. **(Sample answer: Write equivalent fractions.  $\frac{3}{4} = \frac{6}{8} = \frac{9}{12} = \frac{15}{20}$ )**
- Ask, “If there were 72 counters in section M, how many counters would be needed in section L?” **(54)**

**Extension**

In pairs, have students work together asking how many counters should be placed in sections K, L, and P as they change the number of counters in sections J, M, and N.



# Hands-On Lab Recording Sheet

(Use with the activity on page 296 in Lesson 7-2b of the Student Edition)

## Rate of Change

### Materials

square tiles

### Investigate

Work in groups of three. Record your data in the table below. Then graph the ordered pairs  $(x, y)$  on the coordinate plane.

Model	Number of Tiles ( $x$ )	Perimeter ( $y$ )
1	1	4
2	3	8
3		
4		
5		

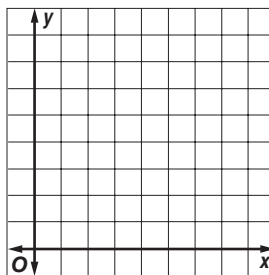

### Writing Math

1. What do you notice about the points?
2. Find the ratio  $\frac{\text{change in perimeter}}{\text{change in tiles}}$  between the second and third points, the third and fourth points, and the fourth and fifth points. Each ratio is a rate of change. **Describe** what you observe.
3. **Complete:** As the number of tiles increases by 2 units, the perimeter of the models increases by   ?   units.
4. Refer to the table at the right that appeared in Lesson 4-7.  
Find the ratio  $\frac{\text{change in earnings}}{\text{change in hours worked}}$  for Greg and Monica.  
How do these values compare to the slopes that you found in Lesson 4-7?

Hours Worked	Earnings (\$)	
	Greg	Monica
1	4	5
2	8	10
3	12	15
4	16	20

5. **Make a conjecture** about the relationship between rate of change and a graph of the two quantities.



# Hands-On Lab Recording Sheet

(Use with the activity on page 301 in Lesson 7-3b of the Student Edition)

## Wildlife Sampling

### Materials

small bowl, dried beans, paper cup, markers

### Investigate

Work in groups of three. Record your data in the table below.

Original Number Captured _____			
Trial	Sample	Recaptured	$P$
A			
B			
C			
D			
E			
F			
G			
H			
I			
J			
<b>Total</b>			

### Write About It

Work in groups of three.

1. Find the average of the estimates in column  $P$ . Is this a good estimate of the number of beans in the bowl? **Explain** your reasoning.
  
2. **Count** the actual number of beans in the bowl. How does this number compare to your estimate?



# Mini-Project

(Use with Lesson 7-4)

## Scale Drawings

### The Room of Your Dreams

**What if you could build a room of any size and put anything you wanted in it?**

**Use the grid as a blueprint. Title your drawing and choose a scale. Then sketch the things you would put in your room, such as a bed, a desk, closet, TV, windows, a door. You can make the furnishings larger or smaller than usual. Make sure you draw everything to scale. Label everything in the room.**

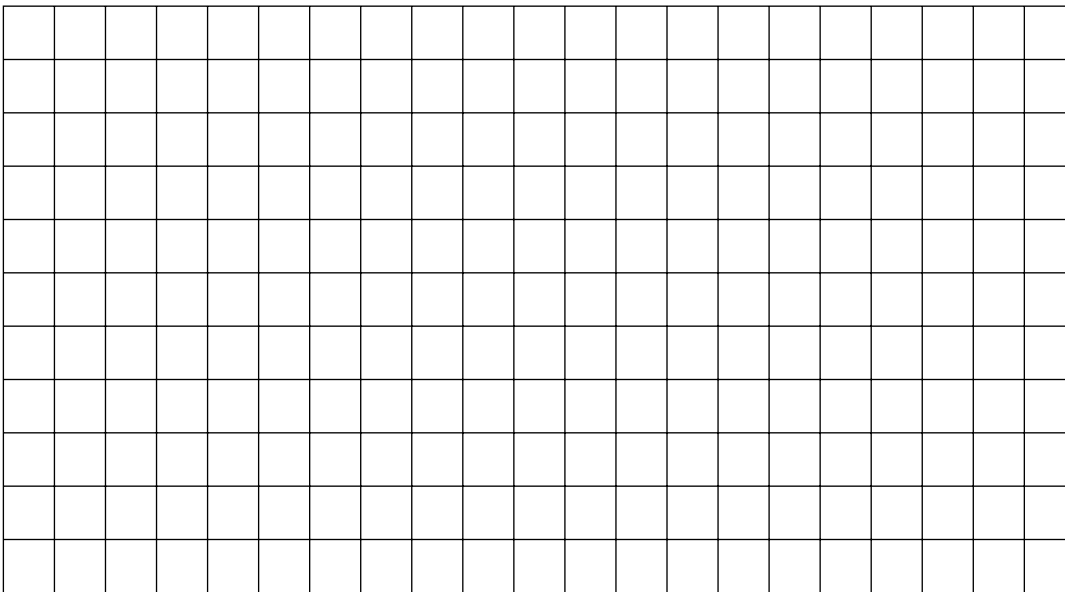

1. List the objects in your room and their actual size.

---

---

---

2. Why did you want these things in your room? \_\_\_\_\_

---

3. Why did you choose these sizes? \_\_\_\_\_

---

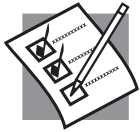

# Hands-On Lab Recording Sheet

(Use with the activity on page 322 in Lesson 7-8a of the Student Edition)

## Using a Percent Model

**Materials:**

none

**Your Turn** Draw a model to find each part.

a. 70% of 50

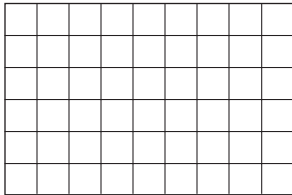

b. 45% of 20

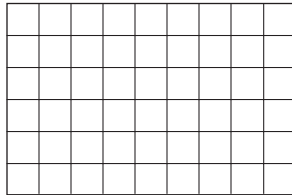

c. 20% of 75

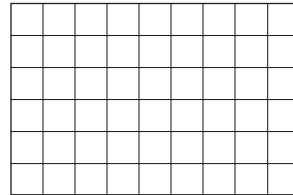

## Writing Math

1. Suppose your whole family had dinner with you and the total bill was \$50. How could you change your model to find the tip?

2. Write a sentence that describes what is represented by the model at the right.

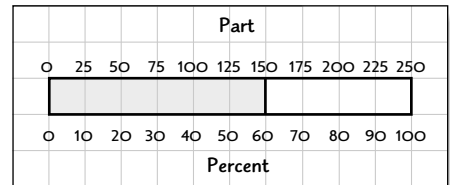

3. Write a percent problem that can be represented and solved using a model.

4. Make a conjecture about how you could use a model to estimate the percent represented by the ratio 8 out of 50.

# Applying Percent

## Teaching Notes and Overview



### Mini-Project

#### Percent and Estimation

(p. 75 of this booklet)

**Use With** Lesson 8-1.

**Objective** Create a scale drawing.

#### Materials

ruler

Using the grid provided, students create a scale drawing of a room they would like to build. The drawing includes everything they wish to include in the room drawn to scale. Students must label their drawing and list the objects in the room and their actual size.

#### Answers

1. See students' work. Make sure drawings are the correct scale based on this information and the scale of the grid.
- 2–3. Answers will vary.



### Hands-On Lab

#### Recording Sheet

#### Sampling

(p. 76 of this booklet)

**Use With** Lesson 8-3a. This corresponds to the activity on page 344 in the Student Edition.

**Objective** Investigate rate of change.

#### Materials

square tiles

Students use tiles to build models and find the perimeter of each model. A table and coordinate plane is provided for students to record and graph their data. Students explore rate of change by finding the slope of the graph.

#### Answers

See Teacher Wraparound Edition p. 344.



### Using Overhead Manipulatives

#### Percent of Change

(pp. 77–78 of this booklet)

**Use With** Lesson 8-4.

**Objective** Use dot paper to show percent of increase and percent of decrease.

#### Materials

rectangular dot paper transparency\*  
transparency pens\*

\* = available in Overhead Manipulative Resources Kit

- Students use models on dot paper to show and find percent of increase and percent of decrease.
- An Extension activity asks students to use a given figure to show an increase and decrease of  $33\frac{1}{3}\%$ .

#### Answers

Answers appear on the teacher demonstration instructions on pages 77–78.





# Mini-Project

(Lesson 8-1)

## Percent and Estimation

Estimate the percent of the shaded portion for each figure. Then count grid squares to find the actual percent shaded.

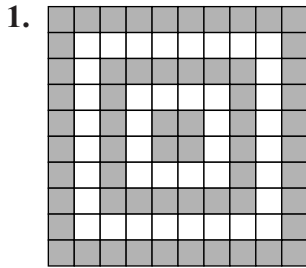

Estimate: \_\_\_\_\_

Actual: \_\_\_\_\_

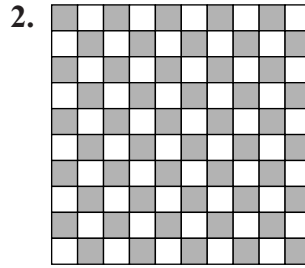

Estimate: \_\_\_\_\_

Actual: \_\_\_\_\_

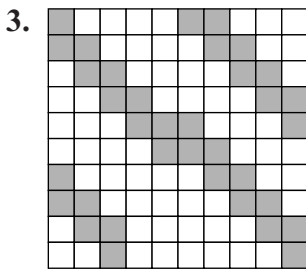

Estimate: \_\_\_\_\_

Actual: \_\_\_\_\_

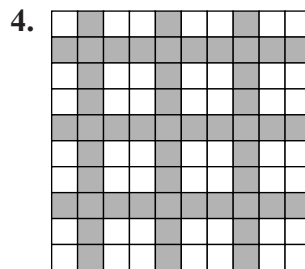

Estimate: \_\_\_\_\_

Actual: \_\_\_\_\_

5. How did your estimates compare with the actual percents?

\_\_\_\_\_

6. Shade your own grid. Estimate the percent shaded and count to find the exact percent.

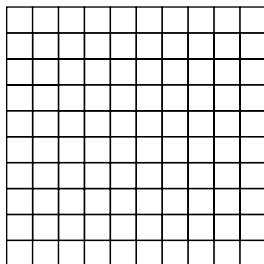

Estimate: \_\_\_\_\_

Actual: \_\_\_\_\_



# Hands-On Lab Recording Sheet

(Use with the activity on page 344 in Lesson 8-3a of the Student Edition)

## Sampling

### Materials:

none

### Writing Math

*Work in groups of three.*

**State whether each sample is random. Explain.**

1. To determine the favorite spectator sport for women over 25 years old, 350 women over 25 are surveyed at a professional basketball game.
2. To collect data about the study habits of middle school students in the Franklin School District, the name of every middle school student in the district is placed in a bag and 250 names are randomly selected.

**For Exercises 3-7, refer to the information below.**

Suppose you are to survey students in your school.

3. Formulate a hypothesis about students' activities.
4. Design and conduct a survey. Describe the technique that you used to get a random sample.
5. Use the back of this sheet to organize and display the results of your survey in a table or graph.
6. Analyze ways in which the wording of your questions might have changed the outcome of the survey.
7. Use the results of your survey to evaluate your hypothesis.



# Using Overhead Manipulatives

(Use with Lesson 8-4)

## Percent of Change

**Objective** Use dot paper to show percent of increase and percent of decrease.

**Materials**

- rectangular dot paper transparency\*
- transparency pens\*

\* = available in Overhead Manipulative Resources Kit

### Teacher Demonstration

- Ask students for the meaning behind expressions such as *a 5% increase in salary* and *a 20% decrease in cost*. Explain that such percents are referred to as percents of increase and decrease.
- Explain that percent increase and percent decrease can be modeled with dot paper.
- Make a 2-by-5 rectangle like the one shown below in Figure A. Tell students you want to decrease the area of the rectangle by 10%. Separate the rectangle into 10 equal parts as in Figure B.

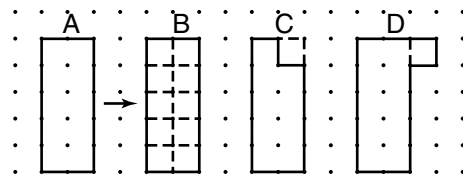

- Remove 10%, or  $\frac{1}{10}$  from the original figure to show a *decrease* of 10%. See Figure C.
- Next, add 10%, or  $\frac{1}{10}$  to the original figure. Tell students that Figure D shows an *increase* of 10% from the original figure.
- Say, “When we decreased the area by 10%, what percent remained?” **(90%)**
- Ask, “If there is a 10% increase in area, what is the ratio of the new area to the old area?”  $\left(\frac{11}{10}\right)$  Then ask students to write the ratio as a percent. **(110%)**
- Ask, “If there is a 10% decrease in area, what is the ratio of the new area to the old area?”  $\left(\frac{9}{10}\right)$  Ask students to write the ratio as a percent. **(90%)**

**Have students complete Exercise 1.**

1. Refer to the figures at the right. By what percent was the original figure decreased? Explain how you determined the percent.

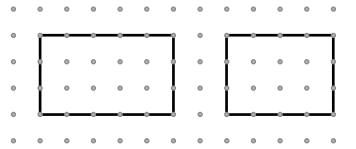

**(20%; If the rectangle is divided into 5 sections, then 1 of the sections was removed. The decrease is  $\frac{1}{5}$ , or 20%.)**

**Extension**

Use Figures X, Y, and Z below. Ask students how to determine by what percent the original figure was increased or decreased. **(X: 4 of Y's sections were removed, so the decrease is 4 of 8, or 50%. Z: Y's 8 sections were expanded by 4 sections, so the increase is 4 of 8, or 50%.)**

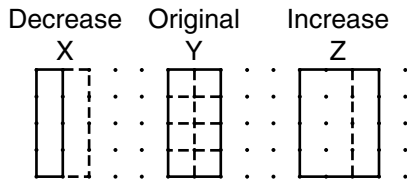

Show students Figure R. Ask them what fraction is equal to  $33\frac{1}{3}\%$ .  **$\left(\frac{1}{3}\right)$**  Ask students how to use Figure R to draw figures that show an increase of  $33\frac{1}{3}\%$  or a decrease of  $33\frac{1}{3}\%$ . **(Divide the figure into 12 equal sections. Show an increase of  $33\frac{1}{3}\%$  by adding 4 sections to the original figure. Show a decrease of  $33\frac{1}{3}\%$  by removing 4 sections from the original figure.)**

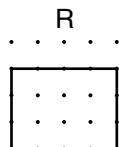

# Probability

## Teaching Notes and Overview



### Using Overhead Manipulatives

**Exploring Permutations**  
(pp. 81–82 of this booklet)

**Use With** Lesson 9-4.

**Objective** Explore permutations.

#### Materials

transparency pen\*  
blank transparency cut into three rectangles  
2 blank transparencies

\* = available in Overhead Manipulative Resources Kit

This demonstration contains two activities.

- Demonstration 1 shows how to list all the possible arrangements of three subjects.
- Demonstration 2 shows how to use a tree diagram to show all the possible arrangements of the three subjects.
- An Extension activity asks students to find the total number of possible arrangements of five classes.

#### Answers

Answers appear on the teacher demonstration instructions on pages 81–82.



### Hands-On Lab Recording Sheet

**Exploring Combinations**  
(p. 83 of this booklet)

**Use With** Lesson 9-5a. This corresponds to the activity on page 386 in the Student Edition.

**Objective** Find combinations.

#### Materials

5 index cards

Using index cards labeled with sundae toppings, students find combinations by choosing toppings to make different sundaes. Students will compare and contrast a combination and a permutation, as well as make conclusions on how to find a combination given a permutation.

#### Answers

See Teacher Wraparound Edition p. 386.



### Mini-Project

**Theoretical and Experimental Probability**

(p. 84 of this booklet)

**Use With** Lesson 9-6.

**Objective** Find theoretical and experimental probability.

#### Materials

coins

Students toss a coin several times and record the results. They find theoretical and experimental probability, then compare and contrast both probabilities.

#### Answers

**Sample data:** T, T, T, H, T, T, H, T, H, T

1. Sample answer: 7
2. Sample answer:  $\frac{7}{10}$
3.  $\frac{1}{2}$
4. Sample answer: No, in this case the experimental probability is much larger.
5. Sample answer: 27
6. Sample answer: 25; I would expect the coin to land tail side up half of the time.

7. Sample answer:  $\frac{27}{50}$
8.  $\frac{1}{2}$ ; They are the same.
9. Sample answer: No, but it is closer than for 10 tosses.
10. Sample answer: The experimental probability was not the same as the theoretical probability. However, the experimental probability of the second experiment was closer to the theoretical probability, suggesting that the more trials you have, the closer the experimental probability will be to the theoretical.



## **Hands-On Lab Recording Sheet**

**Experimental Probability**  
(p. 85 of this booklet)

**Use With** Lesson 9-6b. This corresponds to the activity on page 397 in the Student Edition.

**Objective** Investigate experimental probability.

### **Materials**

paper  
scissors  
spinner arrows

Students work with a partner to create a spinner and record the results of 25 spins. They combine their results with four other pairs of students to obtain the results of 100 spins. Using this data, students find experimental probabilities written as percents.

### **Answers**

See Teacher Wraparound Edition p. 397.



# Using Overhead Manipulatives

(Use with Lesson 9-4)

## Exploring Permutations

**Objective** Explore permutations.

**Materials**

- transparency pen\*
- blank transparency cut into three rectangles
- 2 blank transparencies

\*Available in Overhead Manipulative Resources

### Teacher Demonstration for Activity 1

- Write math, science, and language arts on the transparency rectangles. Also prepare a transparency with the tree diagram shown in Activity 2.
- Ask a student to choose one of the three subjects as the first class of the day. Place the card at the top of the screen. Have them choose one of the remaining subjects for the second class. Place that card below the first. Place the remaining card below the second and point out that it is the third class.
- Record the arrangement of classes on the blank transparency.
- Have students suggest other arrangements until you have found all of the possible arrangements.

### Teacher Demonstration for Activity 2

- Clear the screen. Tell students that you can also make a tree diagram to show the possible arrangements. Show them the following tree diagram. (Leave spaces where answers are given in parentheses.)

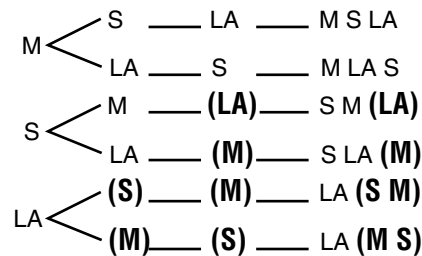

- Ask, “When we first started to make the list or the tree diagram, how many choices were there for the first class?” **(3)**
- Ask, “Once the first class was chosen, how many choices were there for the second class?” **(2)**
- Ask, “Once the first two were chosen, how many choices were there for the third class?” **(1)**

- Ask how many arrangements were possible. **(6 arrangements)**
- Ask students to explain how to use the Counting Principle to find the number of arrangements. **( $3 \times 2 \times 1 = 6$ )**
- Say, “Suppose we added a fourth class. How many arrangements would be possible?” **(24 arrangements)**

***Extension***

Have students determine the total number of possible arrangements of five classes. **(120)**





# Hands-On Lab Recording Sheet

(Use with the activity on page 386 in Lesson 9-5a of the Student Edition)

## Exploring Combinations

### Materials

5 index cards

### Investigate

*Work with a partner.*

To make a sundae, select any pair of cards. Make a list of all the different combinations that are possible. Note that the order of the toppings is not important.

### Writing Math

*Work with a partner.*

1. How many different combinations are possible with two toppings?
2. How many different sundaes could be made with two toppings if the order of the toppings *was* important? What is this type of arrangement called?
3. **Write** a fifth topping on an index card. Now find all two-topping sundae combinations. How many are there? How many sundaes can be made with two toppings if the order of the toppings was important?
4. **Compare and contrast** the way you can find a permutation with the way you find a combination.
5. **Make a conjecture** about how to find a combination given a permutation.



# Mini-Project

(Use with Lesson 9-6)

## Theoretical and Experimental Probability

**Toss a coin ten times. Record the results of each toss in the table.**

Toss	1	2	3	4	5	6	7	8	9	10
Result										

- How many times did the coin land with the tail side up? \_\_\_\_\_
- Compute the experimental probability of the coin landing tail side up.  
\_\_\_\_\_
- What is the theoretical probability of the coin landing tail side up? \_\_\_\_\_
- Is the experimental probability the same as the theoretical probability?  
\_\_\_\_\_

**Toss a coin 40 more times. Count the number of times the coin lands tail side up.**

- Including your first 10 tosses, how many times did the coin land tail side up? \_\_\_\_\_
- How many times did you expect the coin to land tail side up? \_\_\_\_\_  
Why did you choose this number? \_\_\_\_\_  
\_\_\_\_\_
- What is the experimental probability for 50 tosses? \_\_\_\_\_
- What is the theoretical probability for 50 tosses? \_\_\_\_\_  
How does this compare to the theoretical probability for 10 tosses? \_\_\_\_\_
- Is the experimental probability for 50 tosses the same as the theoretical probability for 50 tosses? \_\_\_\_\_  
\_\_\_\_\_
- Write a summary statement. Describe any connections you notice. Mention the number of trials, the experimental probability, and the theoretical probability. \_\_\_\_\_  
\_\_\_\_\_  
\_\_\_\_\_  
\_\_\_\_\_  
\_\_\_\_\_

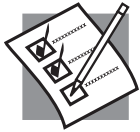

# Hands-On Lab Recording Sheet

(Use with the activity on page 397 in Lesson 9-6b of the Student Edition)

## Experimental Probability

### Materials

paper, scissors, spinner arrows

### Investigate

*Work with a partner.*

Spin the spinner 25 times to model Shannon shooting 25 free throws. Record your results in the table below. If the spinner lands on a line, spin again. Combine your data with four other groups so you have 100 data points.

Outcome	Tally	Total
Made Free Throw		
Missed Free Throw		

### Writing Math

*Work with a partner.*

- 1. Explain** why you combined your data with four other groups.
- From your table, what is the experimental probability of making a free throw?
- How does the experimental probability compare with Shannon's past performance?
- What is the experimental probability of making two free throws in a row?  
**Explain** how you found your answer.
- Suppose Shannon did shoot 100 free throws in a row. What factors would influence her making *or* not making 75 free throws? **Explain** your reasoning.
- 6. Describe** the size of both sections of the spinner.
- 7. Describe** another way to simulate Shannon shooting free throws.
- 8. Draw** a spinner that simulates a free-throw shooter making 60% of her free throws.

# Geometry

## Teaching Notes and Overview



### Hands-On Lab Recording Sheet

#### Measuring Angles

(p. 90 of this booklet)

**Use With** Lesson 10-1a. This corresponds to the activity on page 412 in the Student Edition.

**Objective** Measure angles.

#### Materials

protractor

Students will learn how to use a protractor to measure angles.

#### Answers

See Teacher Wraparound Edition p. 412.



### Hands-On Lab Recording Sheet

#### Constructing and Bisecting Angles

(p. 91 of this booklet)

**Use With** Lesson 10-1b. This corresponds to the activity on pages 416–417 in the Student Edition.

**Objective** Construct and bisect angles.

#### Materials

straightedge  
compass

Students will use a protractor, straightedge, and compass to construct and bisect angles.

#### Answers

See Teacher Wraparound Edition pp. 416–417.



### Using Overhead Manipulatives

#### Jelly Bean Statistics

(p. 92 of this booklet)

**Use With** Lesson 10-2.

**Objective** Make a circle graph.

#### Materials

transparency pen\*  
straightedge\*  
compass\*  
2 blank transparencies

\* = available in Overhead Manipulative Resources Kit

- This demonstration shows how to create a frequency table and circle graph using the students' favorite colors.
- An Extension activity asks students to find the number of degrees in each section of the circle using the percents for each section.

#### Answers

Answers appear on the teacher demonstration instructions on page 92.



### Hands-On Lab Recording Sheet

#### Constructing Parallel Lines

(p. 93 of this booklet)

**Use With** Lesson 10-3b. This corresponds to the activity on pages 426–427 in the Student Edition.

**Objective** Construct parallel lines, and find angle relationships.

**Materials**

straightedge  
compass  
protractor  
colored pencils  
notebook paper

Students work with a partner to construct parallel lines and identify angle relationships. They also use angle relationships to find the measures of unknown angles.

**Answers**

See Teacher Wraparound Edition pp. 426–427.



### **Hands-On Lab Recording Sheet**

**Constructing Triangles**  
(p. 94 of this booklet)

**Use With** Lesson 10-4b. This corresponds to the activity on pages 432–433 in the Student Edition.

**Objective** Construct equilateral and isosceles triangles.

**Materials**

straightedge  
compass  
protractor  
ruler

Students work with a partner to construct an equilateral triangle and an isosceles triangle. Students use their drawings to make conclusions about the measure of the angles in an equilateral triangle and an isosceles triangle.

**Answers**

See Teacher Wraparound Edition pp. 432–433.



### **Using Overhead Manipulatives**

**Investigating Triangles and  
Quadrilaterals**

(pp. 95–96 of this booklet)

**Use With** Lesson 10-5.

**Objective** Discover characteristics of various kinds of triangles and quadrilaterals.

**Materials**

4 × 6 index cards  
scissors  
brass fasteners  
ruler\*  
protractor\*  
blank transparency  
transparency pens\*

\* = available in Overhead Manipulative Resources Kit

This demonstration contains two activities.

- Demonstration 1 shows the relationship between the sides of a triangle and the measures of its angles.
- Demonstration 2 shows the relationship between the sides of a quadrilateral and the measures of its angles.
- An Extension activity asks students to find examples of the use of triangles to make a shape rigid.

**Answers**

Answers appear on the teacher demonstration instructions on pages 95–96.



### **Mini-Project**

**Quadrilateral Tessellations**

(p. 97 of this booklet)

**Use With** Lesson 10-7.

**Objective** Create a tessellation using quadrilaterals.

**Materials**

protractor  
tracing paper  
scissors

Students draw a convex quadrilateral and use it to create a tessellation. Space is provided for students to sketch their tessellation and make conclusions based on their work.

**Answers**

1-6. See students' work.

7.  $360^\circ$

8. Yes; the sum of the angles of a convex quadrilateral is  $360^\circ$ . This means the vertices can be put together so there are no gaps. This is what we need to make a tessellation.



## Using Overhead Manipulatives

**Angles of a Polygon**  
(pp. 98–99 of this booklet)

**Use With** Lesson 10-7.

**Objective** Find the sum of the angle measures of polygons.

**Materials**

protractor\*  
straightedge\*  
transparency pens\*  
blank transparency  
scissors  
construction paper

\* = available in Overhead Manipulative Resources Kit

This demonstration contains two activities.

- Demonstration 1 shows how to form a straight angle using the three angles of any triangle.

- Demonstration 2 shows the relationship between the number of sides of a polygon to the sum of the measures of its angles.
- Students are asked to find the sum of the measures of the angles of polygons with various numbers of sides.

**Answers**

Answers appear on the teacher demonstration instructions on pages 98–99.



## Using Overhead Manipulatives

**Inscribed Polygons**  
(pp. 100–101 of this booklet)

**Use With** Lesson 10-7.

**Objective** Inscribe triangles, squares, and hexagons in circles.

**Materials**

compass\*  
straightedge\*  
wax paper  
ruler\*  
transparency pens\*  
protractor\*  
scissors

\* = available in Overhead Manipulative Resources Kit

This demonstration contains three activities.

- Demonstration 1 shows how to inscribe a square in a circle by using paper folding.
- Demonstration 2 shows how to use a compass and a straightedge to inscribe a square in a circle.
- Demonstration 3 shows how to inscribe other regular polygons in a circle using a compass and straightedge.
- Students will inscribe an equilateral triangle in a circle independently and explain the steps they used.

**Answers**

Answers appear on the teacher demonstration instructions on pages 100–101.



## Using Overhead Manipulatives

### Dilations

(pp. 102–103 of this booklet)

**Use With** Lesson 10-8b.

**Objective** Enlarge a figure on a coordinate plane.

### Materials

transparency pens\*  
 straightedge\*  
 transparency of a simple picture or a small cartoon  
 centimeter grid transparency

\* = available in Overhead Manipulative Resources Kit

- This demonstration shows how to enlarge a cartoon or picture using a centimeter grid transparency.
- An Extension activity demonstrates how to reduce a cartoon or picture using a centimeter grid transparency.

**Answers**

Answers appear on the teacher demonstration instructions on pages 102–103.



## Hands-On Lab Recording Sheet

### Rotations

(p. 104 of this booklet)

**Use With** Lesson 10-9b. This corresponds to the activity on pages 460–461 in the Student Edition.

**Objective** Graph rotations on a coordinate plane.

### Materials

graph paper  
 protractor  
 ruler

Students will graph and describe rotations. They will also identify different types of transformations.

**Answers**

See Teacher Wraparound Edition pp. 460–461.







# Hands-On Lab Recording Sheet

(Use with the activity on pages 416–417 in Lesson 10-1b of the Student Edition)

## Constructing and Bisecting Angles

### Materials

straightedge, compass

**ACTIVITY 1** *Work with a partner. Use a separate sheet of paper for your drawings.*

### Your Turn

Use the space below for your drawings.

- Draw an obtuse angle. Then construct an angle congruent to it.

**ACTIVITY 2** *Work with a partner. Use a separate sheet of paper for your drawings.*

### Your Turn

Use the space below for your drawings.

- Draw a right angle. Then bisect it.

### Writing Math

*Work with a partner.*

- Explain** how you could verify that  $\angle ABC$  and  $\angle MLK$  in Activity 1 are congruent.
- Explain** how you could verify that  $\angle DEF$  in Activity 2 is bisected.
- A straight angle has a measure of  $180^\circ$ . What kind of angle is formed if you bisect a straight angle?
- Use a compass and a straightedge to construct perpendicular lines.



# Using Overhead Manipulatives

(Use with Lesson 10-2)

## Jelly Bean Statistics

**Objective** Make a circle graph.

**Materials**

- transparency pen\*
- compass\*
- straightedge\*
- 2 blank transparencies

\* = available in Overhead Manipulative Resources Kit

### Teacher Demonstration

- Survey the class to find each member's favorite color. Record responses on a frequency table.

- Keeping the colors together, arrange the first letter of the colors in a circle like the one shown. Use a compass to draw a circle the same size.

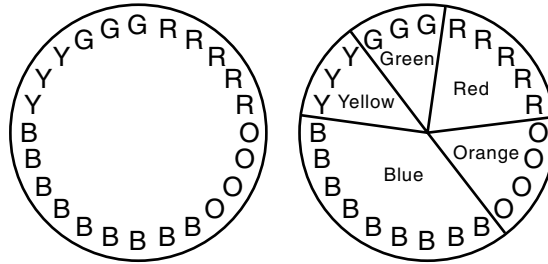

- On the circle, mark sections to indicate the separation of colors. Draw a radius from each mark on the circle to the center as shown.

- Label each section by color.
- Tell students that this is a circle graph. It is a different way to present the information that was contained in the frequency table.
- Ask students if there is a relationship between the number of tally marks in the frequency table and the size of the section of the circle by color. **(The more tally marks, the greater the section.)**
- Have students use the percent proportion or percent equation to find the percent represented by each color. Label the percent in each section on the graph.
- Ask students to explain how the ratio of each color to the whole is represented on the circle graph. **(The ratio of each color to the whole is shown by the portion of the graph used for that color.)**
- Point out that the graph shows the same information as the frequency table. Discuss the advantages and disadvantages of each.

### Extension

Ask students to find the number of degrees in each section of the circle using the percents found above. Have them compare the number of degrees in each section with the actual circle graph.

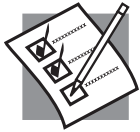

# Hands-On Lab Recording Sheet

(Use with the activity on pages 426–427 in Lesson 10-3b of the Student Edition)

## Constructing Parallel Lines

### Materials

straightedge, compass, protractor, colored pencils, notebook paper

**ACTIVITY 1** *Work with a partner. Use a separate sheet of paper for your drawings.*

### Your Turn

- Draw a line below. Then construct a line parallel to it.

**ACTIVITY 2** *Work with a partner. Use a separate sheet of paper for your drawings.*

### Writing Math

- Explain** why you think  $\angle 1$ ,  $\angle 2$ ,  $\angle 7$ , and  $\angle 8$  are called exterior angles.
- Explain** why you think  $\angle 3$ ,  $\angle 4$ ,  $\angle 5$ , and  $\angle 6$  are called interior angles.
- What are  $\angle 2$  and  $\angle 4$  called?
- If you know only one angle measure in the figure, **explain** how you can find the measures of the other angles without measuring.
- Predict the measure of the other angles in the figure at the right using the  $45^\circ$  angle. Then copy the figure onto notebook paper and check by using a protractor.

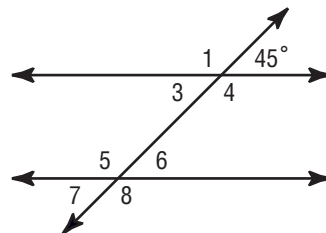

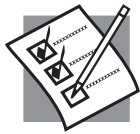

# Hands-On Lab Recording Sheet

(Use with the activity on pages 432–433 in Lesson 10-4b of the Student Edition)

## Constructing Triangles

### Materials

straightedge, compass, protractor, ruler

**ACTIVITY 1** *Work with a partner. Use a separate sheet of paper for your drawings.*

### Your Turn

- a. Construct equilateral triangle  $TUV$  with sides measuring 3 inches.

**ACTIVITY 2** *Work with a partner. Use a separate sheet of paper for your drawings.*

### Your Turn

- b. Construct isosceles triangle  $XYZ$  with sides measuring 3 inches, 5 inches, and 5 inches.

### Writing Math

*Work with a partner.*

1. **Measure** the angles in the equilateral triangle you constructed with a protractor. Compare your measurements with other groups.
2. **Make a conjecture** about the measure of the angles of an equilateral triangle.
3. **Measure** the angles in the isosceles triangle you constructed with a protractor. Compare your measurements with other groups.
4. **Make a conjecture** about the measure of the angles of an isosceles triangle.



# Using Overhead Manipulatives

(Use with Lesson 10-5)

## Investigating Triangles and Quadrilaterals

**Objective** Discover characteristics of various kinds of triangles and quadrilaterals.

**Materials**

- $4 \times 6$  index cards
- scissors
- brass fasteners
- ruler\*
- protractor\*
- blank transparency
- transparency pens\*

\* = available in Overhead Manipulative Resources Kit

### Teacher Demonstration for Activity 1

- Cut  $\frac{1}{2}$ -inch wide strips from the index cards. You will need four 3-inch long strips, four 5-inch long strips, and four 6-inch long strips. Place the strips on top of a blank transparency and label by length.
- Ask students to suggest three strips you can use to make a triangle with three congruent sides. Use the strips and fasteners to make the triangle. Place it on the transparency and label it Triangle *A*. Measure the angles of the triangle and record.
- Repeat for at least two other triangles with three congruent sides.
- Ask students to suggest three strips you can use to make a triangle with exactly two congruent sides. Make the triangle and label it Triangle *B*. Measure the angles of the triangle and record.
- Repeat for at least two other triangles with exactly two congruent sides.
- Ask students to suggest three strips you can use to make a triangle with no congruent sides. Make the triangle and label it Triangle *C*. Measure the angles of the triangle and record.
- Repeat for at least two other triangles with no congruent sides.
- Ask students what conclusions they can make about the angles of a triangle with three congruent sides. **(All the angles have the same measure,  $60^\circ$ .)** Ask what conclusions they can make about the angles of a triangle with exactly two congruent sides. **(The angles opposite the congruent sides have the same measure.)** Ask what conclusions they can make about the angles of a triangle with no congruent sides. **(None of the angles have the same measure.)**

**Teacher Demonstration for Activity 2**

- Ask students to suggest four congruent strips you can use to make a quadrilateral. Join them with brass fasteners to form a quadrilateral with four right angles. Label it quadrilateral  $D$ . Record the measure of the angles and sides.
- Shift the figure into a different-shaped quadrilateral. Label it quadrilateral  $E$ . Have a student measure its angles. Record the angle measures. Ask students what pattern they notice. **(The two opposite angles have the same measure; the sum of adjacent angles is always  $180^\circ$ .)**
- Have students suggest two sets of congruent strips. Use the strips to make a quadrilateral with four right angles. Label it quadrilateral  $F$  and record the measures of its angles.
- Shift the figure into a different-shaped quadrilateral. Label it quadrilateral  $G$ . Have a student measure its angles. Record the angle measures. Ask students what pattern they notice. **(The two opposite angles have the same measure; the sum of adjacent angles is always  $180^\circ$ .)**
- Repeat this activity using different strips. Have students compare the findings with those above.
- Point out that you were able to shift the quadrilaterals so that the angles changed. Ask students whether they think you can shift a triangle into a different triangle. Make several different triangles and demonstrate that they cannot be shifted.

**Have students complete Exercises 1–2.**

1. Suppose you were building a bookcase. The outside is in the shape of a rectangle.
  - a. Would you expect the rectangle to be rigid or would you expect it to shift? **(shift)**
  - b. How could you make the bookcase more rigid? **(Add a diagonal support, which makes two triangles.)**
2. **Make a conjecture** about why triangles are often used in the construction of buildings. **(Triangles are rigid shapes and do not shift.)**

**Extension**

Have students look for other examples of the use of triangles to make a shape rigid. **(Sample answer: bridge construction)**



# Mini-Project

*(Use with Lesson 10-7)*

## **Quadrilateral Tessellations**

1. A convex polygon is a polygon whose diagonals lie entirely within the polygon. Draw a convex quadrilateral with four different angles.
  
  
  
  
  
  
  
  
  
  
2. Measure the angles of your quadrilateral with a protractor. Write the measure of each angle on the drawing.
3. Use tracing paper to make at least 8 copies of your quadrilateral.
4. Use scissors to carefully cut out your 8 quadrilaterals.
5. Rearrange the quadrilaterals until they form a tessellation pattern.
6. Sketch the tessellation pattern you found.

7. What is the sum of the angles of your quadrilateral? \_\_\_\_\_

8. Do you think any convex quadrilateral will tessellate? \_\_\_\_\_

Why or why not? \_\_\_\_\_

---

---

---

---



# Using Overhead Manipulatives

(Use with Lesson 10-7)

## Angles of a Polygon

**Objective** Find the sum of the angle measures of polygons.

### Materials

- protractor\*
- straightedge\*
- transparency pens\*
- blank transparency
- scissors
- construction paper

\* = available in Overhead Manipulative Resources Kit

### Teacher Demonstration for Activity 1

- Cut out of construction paper three triangles: one acute, one right (use the corner of the construction paper), and one obtuse.



- Using the acute triangle, tear off the angles and arrange as shown.
- Ask students what type of angle is formed. **(a straight angle)**
- Ask students what the measure of this type of angle is. **( $180^\circ$ )**
- Using the right and obtuse triangles, repeat the steps above.

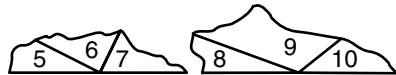

- Ask students to state a conclusion about the sum of the measures of the angles of any triangle. **(The sum is always  $180^\circ$ .)**

### Teacher Demonstration for Activity 2

- Draw a convex pentagon.
- Pick one vertex and draw all the diagonals possible from that vertex.

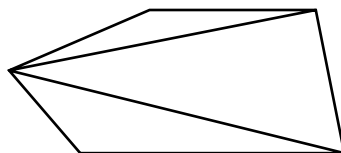



- Ask students how many triangles are formed. **(3)**
- Ask students if the sum of the measures of the angles of the pentagon are equal to the sum of the measures of the triangles formed. **(yes)**
- Ask students to find the sum of the measures of the angles of the pentagon. **(540°)**
- Ask students to relate the number of sides of the pentagon with the sum of the measures of the angles of the pentagon. **(The sum of the measures of the angles of the pentagon is 180° times the difference between the number of sides and two.)**

***Have students complete Exercises 1–2.***

1. Find the sum of the measures of the angles of a figure with the given number of sides.  
a. 5 **(540°)**      b. 6 **(720°)**      c. 8 **(1,080°)**      d. 10 **(1,440°)**
2. If  $n$  is the number of sides of a figure, write an algebraic expression that tells the sum of the measures of the angles of the figure. **(180( $n - 2$ ))**

***Extension***

Ask students to find the sum of the measures of the angles of a convex polygon if it has 15 sides; 22 sides;  $n$  sides. **(2,340°; 3,600°; 180°( $n - 2$ ))**



# Using Overhead Manipulatives

(Use with Lesson 10-7)

## Inscribed Polygons

**Objective** Inscribe triangles, squares, and hexagons in circles.

**Materials**

- compass\*
- wax paper
- transparency pens\*
- scissors
- straightedge\*
- ruler\*
- protractor\*

\* = available in Overhead Manipulative Resources Kit

### Teacher Demonstration for Activity 1

- Tell students that a polygon is an *inscribed* polygon if each of its vertices lies on a circle. Place a piece of wax paper on the screen. Use the compass to draw a circle. Then cut out the circle. Tell students that you are going to inscribe a square in a circle by using paper folding.
- Place the circle on the screen and fold it in half and in half again.
- Open the circle and use the straightedge to draw line segments along the folds. Ask students what the line segments do to the circle. **(Divide it into 4 equal sections.)** Connect the points where the segments intersect the circle.

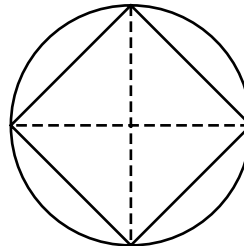

### Teacher Demonstration for Activity 2

- Tell students you can also use a compass and straightedge to inscribe a square in a circle. Draw a circle on a blank transparency. Mark the center of the circle.
- Draw a diameter through the center of the circle. Ask students how to construct a segment through the center of the circle perpendicular to the diameter you have drawn. **(Use a compass to draw arcs on the line, equidistant from the center. Open the compass a little more and draw arcs above and below the line using the points on the line where the arc intersects the line. Connect the points where those arcs intersect.)**
- Use the straightedge to connect the points where the diameter and its perpendicular meet the circle. Connect the points in order.

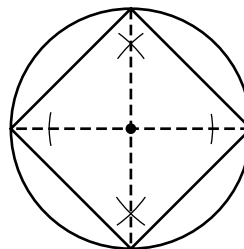

- Have a student use the protractor to measure the angles of the quadrilaterals. Have another student use the ruler to measure the sides. Ask students what they find. **(The angles measure  $90^\circ$  and the sides are congruent.)**

**Have students complete Exercise 1.**

1. Explain how the paper folding method is similar to using a compass and straightedge. **(Sample answer: Folding the circle once is like drawing a diameter; folding it the second time is like drawing the perpendicular line.)**

**Teacher Demonstration for Activity 3**

- Tell students that you can also inscribe other regular polygons in a circle using a compass and straightedge.
- Draw a circle with the compass. Put a point on the circle.
- With the same setting, place the compass on the point. Draw a small arc that intersects the circle. Place the compass on the point where the arc intersects the circle. Draw another small arc that intersects the circle. Continue this process until you come back to the original point.

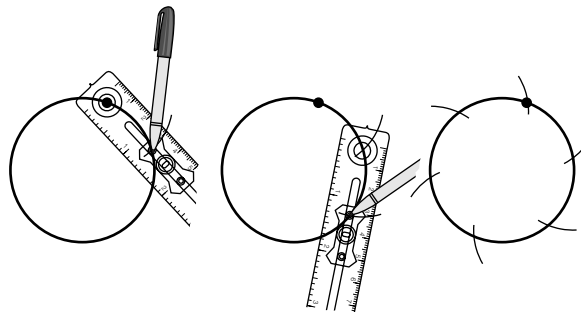

- Use a straightedge to connect the points of intersection in order. Ask the students what is true about all of the segments. **(They are congruent.)**
- Have a student use the protractor to measure the angles of the hexagon. Ask students what they find. **(The angles measure  $120^\circ$ .)**
- Ask students if this is a regular hexagon. **(yes)**



**Have students complete Exercise 2.**

2. Inscribe an equilateral triangle in a circle. Explain the steps you used. *(Hint: Modify the steps you used to inscribe a hexagon in a circle.)* **(Sample answer: Follow the same steps to inscribe a hexagon in a circle, but connect every other intersection point with a line segment.)**



# Using Overhead Manipulatives

(Use with Lesson 10-8b)

## Dilations

**Objective** Enlarge a figure on a coordinate plane.

### Materials

- transparency pens\*
- straightedge\*
- transparency of a simple picture or a small cartoon
- centimeter grid transparency

\* = available in Overhead Manipulative Resources Kit

### Teacher Demonstration

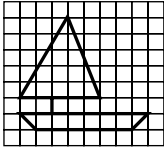
- Place the centimeter grid transparency over a transparency of a cartoon or picture. Tape the two transparencies together to avoid slippage.
- 
- Tape a blank transparency on top of the centimeter grid transparency. Use a colored transparency pen to draw horizontal lines every 2 squares. Then draw vertical lines every 2 squares.
  - Remove the transparency of the picture and the centimeter grid transparency.
  - Sketch the parts of the figure contained in each small square of the original picture onto each large square of the grid created.

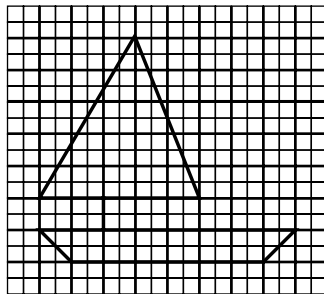

- Ask students if the picture was enlarged or reduced and by how much.  
**(Enlarged; figure is four times as large as original.)**

**Have students complete Exercises 1–2.**

1. Is the enlargement similar to the original drawing? Explain your reasoning.  
**(Yes; each part of the drawing is proportional to the enlargement.)**
2. What type of grid would you use to *reduce* a picture? **(one with smaller squares)**

**Extension**

- Put the enlarged picture aside and remove the original picture from the centimeter grid transparency.
- Tape a blank transparency on top of the centimeter grid transparency. Use a colored transparency pen to draw horizontal lines every 3 squares. Then draw vertical lines every 3 squares.
- Place the grid you have just created over the transparency of the original picture. Tape the two together to avoid slippage.
- Sketch the parts of the figure contained in each 3-by-3 square of the original picture onto each small square of the centimeter grid transparency.

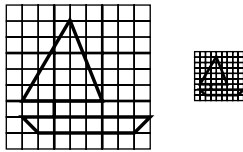

- Ask students if the picture was enlarged or reduced and by how much.  
**(Reduced; figure is one ninth the size of the original.)**

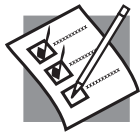

# Hands-On Lab Recording Sheet

(Use with the activity on pages 460–461 in Lesson 10-9b of the Student Edition)

## Rotations

### Materials

graph paper, protractor, ruler

### Your Turn

- Rotate  $\triangle DEF$   $90^\circ$  counterclockwise about the origin. Then graph  $\triangle D'E'F'$ .
- Rotate  $\triangle D'E'F'$  from Part a above  $90^\circ$  counterclockwise about the origin. Then graph  $\triangle D''E''F''$ .

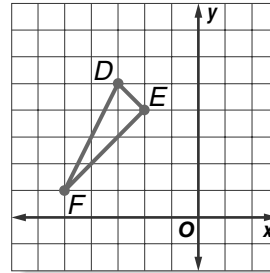

### Your Turn

Refer to page 461. Identify the transformation as a *translation*, *reflection*, or *rotation*. Write your answers below.

- |    |    |
|----|----|
| c. | d. |
| e. | f. |

### Writing Math

*Work with a partner.*

- Rotate  $\triangle DEF$  from Example 1a  $180^\circ$  counterclockwise. Compare your rotated figure with your answer from Example 1b.
- Make a conjecture** about rotating figures  $180^\circ$ .
- Without rotating  $\triangle DEF$   $360^\circ$ , **make a conjecture** about rotating figures  $360^\circ$ . Describe the figure after a  $360^\circ$  rotation.
- A  $60^\circ$  *counterclockwise* rotation is the same as a  $-300^\circ$  *clockwise* rotation. Find an equivalent rotation of a  $90^\circ$  counterclockwise rotation.
- Complete the following sentence. Since you can rotate figures in clockwise or counterclockwise directions, a  $270^\circ$  counterclockwise rotation produces the same result as a ? clockwise rotation.

# Geometry: Measuring Two-Dimensional Figures

## Teaching Notes and Overview



### Hands-On Lab Recording Sheet

**The Pythagorean Theorem**  
(p. 107 of this booklet)

**Use With** Lesson 11-3a. This corresponds to the activity on page 478 in the Student Edition.

**Objective** Find the relationship among the sides of a right triangle.

#### Materials

centimeter grid paper  
ruler  
scissors

Students will cut out a right triangle and three squares with side lengths to correspond to the lengths of the sides of the triangle. Using these figures, students will find the relationship among the sides of a right triangle. They will repeat the activity with two other right triangles and summarize their findings.

#### Answers

See Teacher Wraparound Edition p. 478.



### Using Overhead Manipulatives

**Area**  
(pp. 108–109 of this booklet)

**Use With** Lesson 11-4.

**Objective** Use models to find the areas of rectangles and parallelograms.

#### Materials

centimeter grid transparency\*  
transparency pens\*  
tracing paper  
scissors

\* = available in Overhead Manipulative Resources Kit

This demonstration contains two activities.

- Demonstration 1 shows how to find the area of a rectangle on a centimeter grid.
- Students will find the area of rectangles independently.
- Demonstration 2 shows how to find the area of a parallelogram on a centimeter grid.
- Students will find the area of parallelograms independently.
- An Extension activity asks students to explain how the area of a parallelogram changes if the measure of the base and height are doubled.

#### Answers

Answers appear on the teacher demonstration instructions on pages 108–109.



### Hands-On Lab Recording Sheet

**Triangles and Trapezoids**  
(p. 110 of this booklet)

**Use With** Lesson 11-5a. This corresponds to the activity on page 488 in the Student Edition.

**Objective** Find the areas of triangles and trapezoids.

**Materials**

centimeter grid paper  
 straightedge  
 scissors  
 tape

Using two triangles to form a parallelogram, students develop the formula for the area of a triangle. Students then use two trapezoids to form a parallelogram to find the formula for the area of a trapezoid.

**Answers**

See Teacher Wraparound Edition p. 488.

**Mini-Project****Areas of Circles, Rectangles, and Squares**

(p. 111 of this booklet)

**Use With** Lesson 11-6.

**Objective** Find the area of shaded regions within inscribed figures.

**Materials**

none

Students apply the formulas for the areas of circles, rectangles, and squares. Using diagrams of inscribed figures, they will find the area of the shaded region.

**Answers**

1.  $30.54 \text{ ft}^2$
2.  $171.90 \text{ yd}^2$
3.  $97.10 \text{ cm}^2$
4.  $13.73 \text{ in}^2$

**Using Overhead Manipulatives****Probability and Area Models**

(pp. 112–113 of this booklet)

**Use With** Lesson 11-8.

**Objective** Estimate the area of a figure by using probability.

**Materials**

centimeter grid transparency\*  
 ruler\*  
 compass\*  
 counters\*  
 blank transparency  
 transparency pen\*

\* = available in Overhead Manipulative Resources Kit

- The class collects data by dropping counters onto the grid transparency with a circle on it. The number of counters that fall inside the circle each time is recorded in a table.
- Students use the probability of a counter landing in the circle to estimate the area of the circle.
- Students complete the activity independently using a triangle and a trapezoid, rather than a circle.

**Answers**

Answers appear on the teacher demonstration instructions on pages 112–113.





NAME \_\_\_\_\_ DATE \_\_\_\_\_ PERIOD \_\_\_\_\_

## Hands-On Lab Recording Sheet

(Use with the activity on page 478 in Lesson 11-3a of the Student Edition)

### *The Pythagorean Theorem*

#### **Materials**

centimeter grid paper, ruler, scissors

#### **Writing Math**

*Work with a partner.*

1. What relationship exists among the areas of the three squares?

**Repeat the activity for each right triangle whose perpendicular sides have the following measures. Write an equation to show your findings.**

2. 6 cm, 8 cm

3. 5 cm, 12 cm

4. **Write** a sentence or two summarizing your findings.

5. **MAKE A CONJECTURE** Determine the length of the third side of a right triangle if the perpendicular sides of the triangle are 9 inches and 12 inches long.



# Using Overhead Manipulatives

(Use with Lesson 11-4)

## Area

**Objective** Use models to find the areas of rectangles and parallelograms.

**Materials**

- centimeter grid transparency\*
- transparency pens\*
- tracing paper
- scissors

\* = available in Overhead Manipulative Resources Kit

### Teacher Demonstration for Activity 1

- Define the **area** of a geometric figure as the number of square units needed to cover the surface of the figure.
- On the centimeter grid transparency, draw a rectangle with a length of 7 units and width of 3 units.
- Ask students to count the number of squares contained within the boundaries of the rectangle. **(21)** Ask students what the area of the rectangle is. **(21 square units)**

### Have students complete Exercises 1–7.

Find the area of each rectangle. Draw rectangles if necessary.

1. length, 8; width, 3 **(24 units<sup>2</sup>)**
2. length, 5; width, 2 **(10 units<sup>2</sup>)**
3. length, 10; width, 8 **(80 units<sup>2</sup>)**
4. length, 9; width, 4 **(36 units<sup>2</sup>)**
5. length, 20; width, 10 **(200 units<sup>2</sup>)**
6. length, 15; width, 9 **(135 units<sup>2</sup>)**
7. Let  $\ell$  represent the length,  $w$  represent the width, and  $A$  represent the area of a rectangle. Write an equation that shows how to find the area if you know the length and width. **( $A = \ell w$ )**

### Teacher Demonstration for Activity 2

- Define a **parallelogram** as a four-sided figure whose opposite sides are parallel.
- Define the **base** and **height** of a parallelogram. Draw a parallelogram with a base of 7 units and a height of 3 units. Use a different colored transparency pen to draw a line to represent the height as shown. Ask students to find the measure of the base and height of the parallelogram. **(height: 3 units; base: 7 units)**

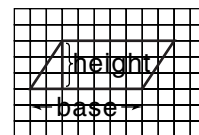

- Trace the parallelogram onto a sheet of tracing paper. Using scissors, cut out the parallelogram. Then cut along the line for the height.
- Place the cut out parallelogram on the centimeter grid transparency and move the triangle to the opposite end of the parallelogram to form a rectangle.
- Remind students that the rectangle in Activity 1 has a length of 7 units and a width of 3 units, and that the parallelogram in Activity 2 has a base of 7 units and a height of 3 units. Ask students to compare the area of these two figures. **(The areas are the same.)**

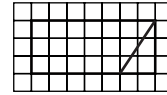

**Have students complete Exercises 8–16.**

**Find the area of each parallelogram by drawing the figure on grid paper, cutting it out, and counting the squares in the newly formed rectangle.**

8.

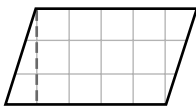
**(15 units<sup>2</sup>)**

9.

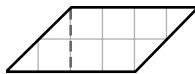
**(8 units<sup>2</sup>)**

10.

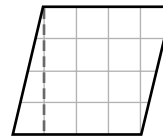
**(16 units<sup>2</sup>)**

11. In Exercises 8–10, how are the base and height of the original parallelogram related to the length and width of the newly formed rectangle? **(The base and height of the parallelogram are the same as the length and width of the rectangle.)**

**Find the area of each parallelogram. Use models if necessary.**

12. base, 6; height, 3 **(18 units<sup>2</sup>)**
13. base, 8; height, 4 **(32 units<sup>2</sup>)**
14. base, 5; height, 5 **(25 units<sup>2</sup>)**
15. base, 10; height, 6 **(60 units<sup>2</sup>)**
16. Let  $b$  represent the base,  $h$  represent the height, and  $A$  represent the area of a parallelogram. Write an equation that shows how to find the area if you know the base and height. **( $A = bh$ )**

### **Extension**

Ask students to explain how the area of a parallelogram changes if the measure of the base and height are doubled. Encourage them to use drawings in their explanations.

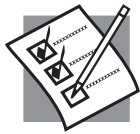

# Hands-On Lab Recording Sheet

(Use with the activity on page 488 in Lesson 11-5a of the Student Edition)

## Triangles and Trapezoids

### Materials

centimeter grid paper, straightedge, scissors, tape

### Writing Math

*Work with a partner.*

1. What figure is formed by the two triangles?
2. Write the formula for the area of the figure. Then find the area.
3. What is the area of each of the triangles? How do you know?
4. Repeat the activity, drawing a different triangle in Step 1. Then find the area of each triangle.
5. Compare the area of a triangle to the area of a parallelogram with the same base and height.
6. **MAKE A CONJECTURE** Write a formula for the area of a triangle with base  $b$  and height  $h$ .

### **For Exercises 7–9, refer to the information below.**

On grid paper, cut out two identical trapezoids. Label the bases  $b_1$  and  $b_2$ , respectively, and label the heights  $h$ . Then turn one trapezoid upside down and tape it to the other trapezoid as shown.

7. Write an expression to represent the base of the parallelogram.
8. Write a formula for the area  $A$  of the parallelogram using  $b_1$ ,  $b_2$ , and  $h$ .
9. **MAKE A CONJECTURE** Write a formula for the area  $A$  of a trapezoid with bases  $b_1$  and  $b_2$ , and height  $h$ .



# Mini-Project

(Use with Lesson 11-6)

## Areas of Circles, Rectangles, and Squares

The rectangle has a length of 8 inches and a width of 6 inches. The radius of the circle is 3 inches.

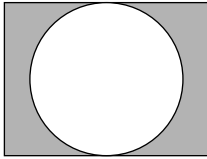

$$\text{Shaded Area} = (\text{area of rectangle}) - (\text{area of circle})$$

$$\text{Shaded Area} = (\text{length} \cdot \text{width}) - (\pi r^2)$$

$$\text{Shaded Area} = (8 \cdot 6) - \pi(3^2)$$

$$\text{Shaded Area} = 48 - 28.27$$

$$\text{Shaded Area} = 19.73 \text{ sq. in.}$$

**Find the area of the shaded regions. Round to the nearest hundredth.**

1.

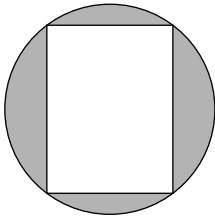

$$\text{radius} = 5 \text{ ft}$$

$$\text{length} = 8 \text{ ft}$$

$$\text{width} = 6 \text{ ft}$$

shaded region = \_\_\_\_\_

2.

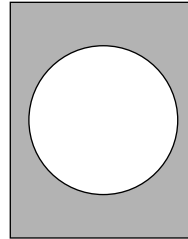

$$\text{radius} = 6 \text{ yd}$$

$$\text{length} = 15 \text{ yd}$$

$$\text{width} = 19 \text{ yd}$$

shaded region = \_\_\_\_\_

3.

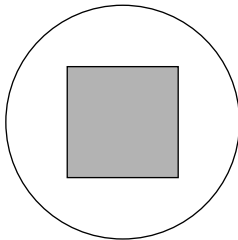

$$\text{radius} = 6 \text{ cm}$$

$$\text{side} = 4 \text{ cm}$$

shaded region = \_\_\_\_\_

4.

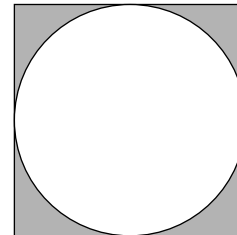

$$\text{radius} = 4 \text{ in.}$$

$$\text{side} = 8 \text{ in.}$$

shaded region = \_\_\_\_\_



# Using Overhead Manipulatives

(Use with Lesson 11-8)

## Probability and Area Models

**Objective** Estimate the area of a figure by using probability.

### Materials

- centimeter grid transparency\*
- ruler\*
- compass\*
- counters\*
- blank transparency
- transparency pen\*

\* = available in Overhead Manipulative Resources Kit

### Teacher Demonstration

- On the grid transparency, draw a square that has sides 16 centimeters long. Inside the square, draw a circle with a radius of 5 centimeters.
- Hold 20 counters about 5 inches above the transparency and drop them onto the transparency.
- Count the number of counters that landed completely within the square. (This includes those that landed within the circle.) Count the number that landed completely inside the circle. Do not count those that landed on the circle itself. These two numbers make up the first sample. Record the results in a table like the one below.

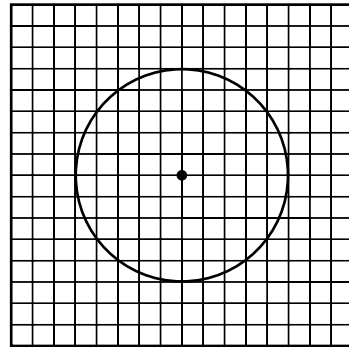

Sample	1	2	3	4	5	6	7	8	9	10	Total
Counters in the square											
Counters in the circle											

- Repeat the two previous steps nine more times, recording the results each time.
- Add the results of the ten samples to find the total number of counters that fell within the square and the total number that fell within the circle.
- Using the totals from the table, have students find the ratio of the total number of counters that fell completely within the circle to the total number of counters that fell completely within the square.

- Tell students that the ratio represents the probability that a counter lands in the circle. This probability can be used to estimate the area of the circle using the following equation.

$$\text{probability} = \frac{\text{area of circle}}{\text{area of square}}$$

- Substitute the probability into the left side of the equation. Have students find the area of the square. **(256 cm<sup>2</sup>)** Substitute it in the denominator of the right side of the equation. Then have students solve the equation to find the area of the circle.
- Have students count the number of grid squares inside the circle to get an estimate of its area. Have them combine two or three partial squares to get a better estimate of the area. Ask how this estimate compares to the experimental probability estimate. **(About 75 cm<sup>2</sup>; they are about the same.)**
- Have students use the radius of 5 centimeters and the formula  $A = \pi r^2$  to find the area of the circle **(about 78.5 cm<sup>2</sup>)** Ask them how the result compares to the probability estimate. **(The results should be similar.)**

***Have students complete Exercises 1–3.***

1. Repeat this activity with a triangle inside the square. **(See students' work.)**
2. Repeat this activity with a trapezoid inside the square. **(See students' work.)**
3. Find the probability that a randomly-dropped counter will fall in the shaded region.  $\left(\frac{2}{7}\right)$

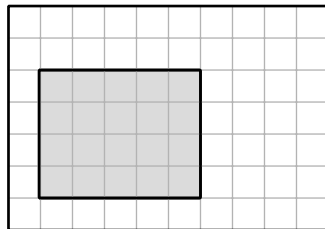

***Extension***

Repeat this activity using other shapes inside the square.

# Geometry: Measuring Three-Dimensional Figures

## Teaching Notes and Overview



### Hands-On Lab Recording Sheet

**Building Three-Dimensional Figures**  
(p. 116 of this booklet)

**Use With** Lesson 12-1a. This corresponds to the activity on pages 512–513 in the Student Edition.

**Objective** Build three-dimensional figures given the top, side, and front views.

#### Materials

cubes

Students will use cubes to build three-dimensional figures given the top, side, and front views. Space is provided for students to sketch their figures. Working with partners, students will create and exchange their own top, side, and front views for their partner to build the appropriate figure.

#### Answers

See Teacher Wraparound Edition pp. 512–513.



### Using Overhead Manipulatives

**Volume of Pyramids**  
(pp. 117–118 of this booklet)

**Use With** Lesson 12-2.

**Objective** Compare the volume of a pyramid with the volume of a prism.

#### Materials

centimeter grid transparency\*  
centimeter grid paper  
transparency pens\*  
rice  
scissors  
tape

\* = available in Overhead Manipulative Resources Kit

- This demonstration shows how to use nets to create a prism and a pyramid.
- By filling the prism and the pyramid with rice, students will compare their volumes.
- An Extension activity asks students to repeat the activity with a different base and height, then compare the results.

#### Answers

Answers appear on the teacher demonstration instructions on pages 117–118.



### Mini-Project

**Volume of Solids**  
(p. 119 of this booklet)

**Use With** Lesson 12-3.

**Objective** Compare the volumes of solids.

#### Materials

paper  
scissors  
tape  
rice

Students trace and cut out nets to create solids. They fill the solids with rice to compare their volumes.



**Answers**

1. Sample answers: rectangular prism; cone; rectangular prism, triangular prism, cylinder, pyramid, and cone
2. rectangular prism; cone; rectangular prism, cylinder, triangular prism, pyramid, and cone
3. Sample answers: Cylinder and triangular prism switched places; a little; Solids do not always have as much volume as they appear to have.



### **Hands-On Lab Recording Sheet**

**Nets and Surface Area**  
(p. 120 of this booklet)

**Use With** Lesson 12-4a. This corresponds to the activity on pages 530–531 in the Student Edition.

**Objective** Use nets to find the surface area of rectangular prisms.

**Materials**

rectangular dot paper  
scissors

Students will draw nets for given figures, find the areas of the nets, and cut them out to build the figures. Students will derive and apply the formula for the surface area of a prism.

**Answers**

See Teacher Wraparound Edition pp. 530–531.



### **Hands-On Lab Recording Sheet**

**Changes in Volume and Surface Area**

(p. 121 of this booklet)

**Use With** Lesson 12-4b. This corresponds to the activity on pages 536–537 in the Student Edition.

**Objective** Investigate changes in volume and surface area.

**Materials**

isometric dot paper

Students will change the dimensions of three-dimensional figures and record the volumes and surface areas. Students will use their data to make conclusions about how changing the dimensions of three-dimensional figures affects volume and surface area.

**Answers**

See Teacher Wraparound Edition pp. 536–537.

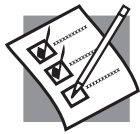

# Hands-On Lab Recording Sheet

(Use with the activity on pages 512–513 in Lesson 12-1a of the Student Edition)

## Building Three-Dimensional Figures

### Materials

cubes

### Your Turn

Use the space below for your sketches.

- a. \_\_\_\_\_ b. \_\_\_\_\_ c. \_\_\_\_\_
- d. \_\_\_\_\_ e. \_\_\_\_\_

### Writing Math

*Work with a partner.*

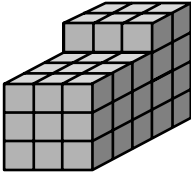
- Build** a model with cubes and draw the top, side, and front views. Give the drawing of the views to your partner and have him or her build the figure with cubes. Repeat with your partner making the drawings and you building the figure.
- Explain** how you began building the figures.
- Determine** whether there is more than one way to build each model. Explain your reasoning.
- The figure at the right represents a building with a section that is 15 stories tall and another section that is 20 stories tall. Which view would you use to show the difference in height of each section?  

- Build** two different models that would look the same from two views, but not the third view. Draw a top view, side view, and front view of each model.
- Describe** a real-life situation where it might be necessary to draw a top, side, and front view of a three-dimensional figure.



# Using Overhead Manipulatives

(Use with Lesson 12-2)

## Volume of Pyramids

**Objective** Compare the volume of a pyramid with the volume of a prism.

### Materials

- centimeter grid transparency\*
- centimeter grid paper
- transparency pens\*
- rice
- scissors
- tape

\*Available in Overhead Manipulative Resources

### Teacher Demonstration

- Prepare the centimeter grid transparency copy with a of the following figure. Cut out the same figure from centimeter grid paper and fold on the dashed lines. Also cut out the net for the pyramid shown several steps later.
- Show students the transparency. Ask them what 3-dimensional figure would be formed by folding the sides up. (**open prism**) Place the figure cut from grid paper on the transparency to show students that it represents the same figure. Fold the sides up and secure with tape to form a model of an open prism.
- On the grid transparency, use a different colored pen to draw the net for a pyramid using the same base. (The height of each triangular face should be about 5.6 cm.)
- Place the figure cut from grid paper on the transparency to show students that it represents the same figure. Fold the sides up and secure with tape to form a model of a pyramid. Point out that the base and height are the same as for the prism.

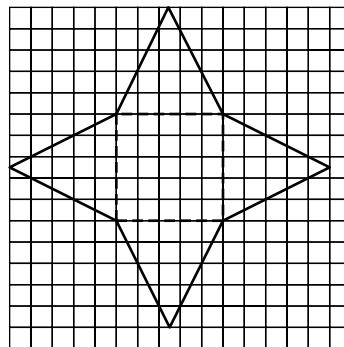
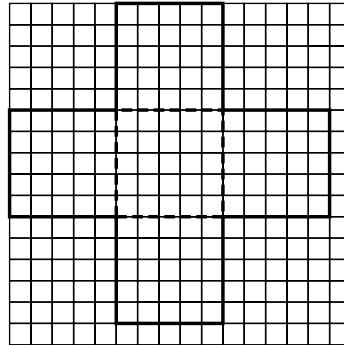

- Ask students to estimate the ratio of the volume of the prism to the volume of the pyramid.
- Make an opening in the base of the pyramid. Fill the pyramid with rice. Then pour the rice into the prism. Repeat until the prism is full.

***Have students complete Exercises 1–5.***

1. How many pyramids of rice did it take to fill the prism?  
**(Sample answer: about 3)**
2. Compare the heights of the prism and the pyramid.  
**(They are equal.)**
3. Compare the areas of the bases of each solid. **(They are equal.)**
4. Compare the volume of the prism and the pyramid.  
**(The volume of the prism is three times the volume of the pyramid.)**
5. Write a formula for the volume of a pyramid. ( $V = \frac{1}{3}\ell wh$ )

***Extension***

Repeat the activity above with a different base and height. Have students compare the results. **(The results are the same.)**



# Mini-Project

(Use with Lesson 12-3)

## Volume of Solids

Create a rectangular prism, triangular prism, pyramid, cone, and cylinder using the patterns. Trace the patterns on paper. Cut them out. Tape the edges together.

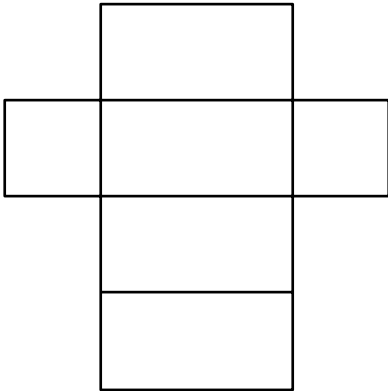

rectangular prism

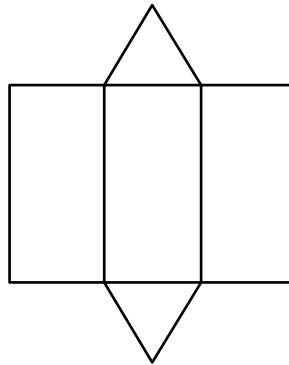

triangular prism

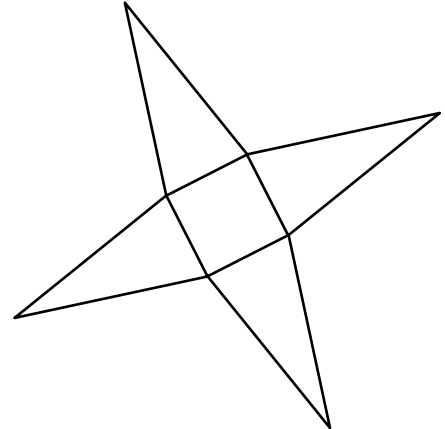

pyramid

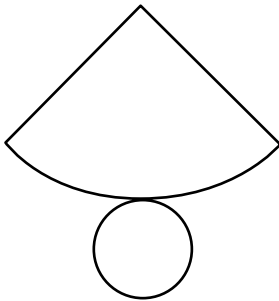

cone

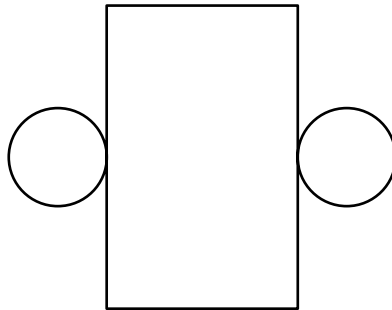

cylinder

- Which solid do you think has the greatest volume? \_\_\_\_\_  
the least? \_\_\_\_\_ Arrange the solids from greatest volume to least  
volume and record the order. \_\_\_\_\_

**Make an opening in each solid. Fill each solid with rice. Compare the amount of rice it takes to fill each solid.**

- Which solid holds the most rice? \_\_\_\_\_ the least rice? \_\_\_\_\_  
Record the solids in order from most rice to least rice. \_\_\_\_\_

- How did the order in Exercise 2 change from the order in Exercise 1?  
\_\_\_\_\_

Did this change surprise you? Explain. \_\_\_\_\_

Name something you learned about the volume of solids. \_\_\_\_\_

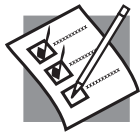

# Hands-On Lab Recording Sheet

(Use with the activity on pages 530–531 in Lesson 12-4a of the Student Edition)

## Nets and Surface Area

### Materials

rectangular dot paper, scissors

### Your Turn

In the space below, list the area of each net.

- a. \_\_\_\_\_ b. \_\_\_\_\_ c. \_\_\_\_\_

### Writing Math

Work in groups of three.

- The net shown on page 530 is made of rectangles. How many rectangles are in the net?
- Explain how you can find the total area of the rectangles.
- The *surface area* of a prism is the total area of its net. Write an equation that shows how to find the surface area of the prism at the right if you know the length  $\ell$ , width  $w$ , and height  $h$ .

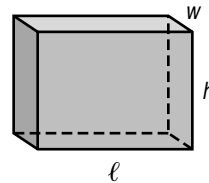

- Find the surface areas of cubes whose edges are 1 unit, 2 units, and 3 units and graph the ordered pairs (side length, surface area) on a coordinate plane. Describe the graph.
- Describe** what happens to the surface area of a cube as its dimensions are doubled? tripled?
- Describe** how you would find the surface area of a square-based pyramid.

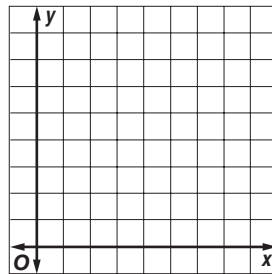

In the space below, draw a net for each figure.

7. \_\_\_\_\_ 8. \_\_\_\_\_

- Explain** how the formula for the surface area of a tetrahedron differs from the formula for the surface area of a square-based pyramid.

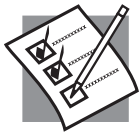

# Hands-On Lab Recording Sheet

(Use with the activity on pages 536–537 in Lesson 12-4b of the Student Edition)

## Changes in Volume and Surface Area

### Materials

isometric dot paper

### Your Turn

a. Complete the table below.

Side Length (units)	Volume (units <sup>3</sup> )	Surface Area (units <sup>2</sup> )	Ratio of Side Length to Volume	Ratio of Side Length to Surface Area
1	$1^3 = 1$	$6(1^2) = 6$	1 : 1	1 : 6
2				
3				
4				
5				
$s$				

### Your Turn

b. Complete the table below.

Side Length (units)	Volume (units <sup>3</sup> )	Surface Area (units <sup>2</sup> )	Ratio of Side Length to Volume	Ratio of Side Length to Surface Area
8	$8^3 = 512$	$6(8^2) = 384$	8 : 512	8 : 384
4				
2				
$s$				

### Writing Math

Work with a partner.

- Write a formula for the volume  $V$  of a cube with side length  $s$ .
- Write a formula for the surface area  $A$  of a cube with side length  $s$ .

Complete each sentence.

- If the side length of a cube is doubled, the volume is ? times greater.
- If the side length of a cube is doubled, the surface area is ? times greater.
- If the side length of a cube is tripled, the volume increases by ? times and the surface area increases by ? times.
- If the side length of a cube decreases by  $\frac{1}{2}$ , the surface area decreases by ?.