

**15-Ton Max. Capacity  
Under 8 Feet Wide**

- Rated Capacity Limiter ... Standard
- Capacity on Outriggers ... 30,000 lbs
- Pick and Carry Capacity ... up to 17,000 lbs
- Height ... 8'
- Width ... 7' 10-1/2"
- Boom Rotation ... 360 Degree Continuous
- Sheave Height ... up to 73' 8"
- Horizontal Reach ... up to 66'
- 4-Wheel Steer ... Standard
- 4-Wheel Drive ... Optional
- Powershift Transmission ... Standard
- Fully Hydraulic Controls for Smooth Precise Operations
- Independent Outrigger Controls
- Dual Fuel Standard, Diesel Optional

**BRODERSON**  
Manufacturing Corp



# IC-200-2H

## CAPACITIES APPLY TO OPERATION ON FIRM LEVEL SURFACE

| LOAD RADIUS FEET              | MAIN BOOM OR EXTENSION CAPACITIES IN POUNDS |               |            |               |      |      |      |
|-------------------------------|---|---------------|------------|---------------|------|------|------|
|                               | 360° ROTATION                               |               | OVER FRONT |               |      |      |      |
|                               | ON RUBBER                                   | ON OUTRIGGERS | ON RUBBER  | ON OUTRIGGERS |      |      |      |
| 6                             | 16200                                       | 30000         | 17000      | 30000         |      |      |      |
| 8                             | 13200                                       | 24000         | 13800      | 24000         |      |      |      |
| 10                            | 10600                                       | 19800         | 11500      | 19800         |      |      |      |
| 12                            | 7800  | 16100         | 9600       | 16100         |      |      |      |
| 14                            | 6100  | 13500         | 7900       | 13500         |      |      |      |
| 16                            | 4900  | 11200         | 6300       | 11200         |      |      |      |
| 18                            | 4000  | 10000         | 5100       | 10000         |      |      |      |
| 20                            | 3300  | 8800          | 4300       | 8800          |      |      |      |
| 22                            | 2800  | 7700          | 3600       | 7800          |      |      |      |
| 24                            | 2350  | 6600          | 3000       | 6900          |      |      |      |
| 26                            | 2050  | 5750          | 2600       | 6200          |      |      |      |
| 28                            | 1800  | 5150          | 2300       | 5700          |      |      |      |
| 30                            | 1600  | 4650          | 2100       | 5300          |      |      |      |
| 32                            | 1400  | 4200          | 1850       | 4900          |      |      |      |
| 36                            | 1150  | 3400          | 1500       | 4200          |      |      |      |
| 40                            | 900   | 3050          | 1200       | 3600          |      |      |      |
| 44                            | 650   | 2600          | 950        | 3100          |      |      |      |
| 48                            | 450   | 2200          | 750        | 2700          |      |      |      |
| 51                            | 250   | 1900          | 600        | 2400          |      |      |      |
| 15' BOOM EXT. EXTENSION ANGLE | 15-FOOT BOOM EXTENSION - STRAIGHT OR OFFSET |               |            |               |      |      |      |
|                               | MAIN BOOM ANGLE                             |               |            |               |      |      |      |
|                               | 0°  | 15°           | 30°        | 40°           | 50°  | 60°  | 70°  |
| 0°                            | ---   | 3100          | 3450       | 3900          | 4650 | 6000 | 7500 |
| 15°                           | ---   | 3000          | 3100       | 3300          | 3650 | 4250 | 5200 |
| 30°                           | ---   | ---           | 3000       | 3050          | 3200 | 3450 | 3900 |

LOAD RADIUS IS THE HORIZONTAL DISTANCE FROM THE CENTER OF ROTATION OF THE UNLOADED CRANE TO THE VERTICAL LOAD LINE WITH THE LOAD APPLIED.

EXCEEDING CAPACITY RATINGS OR APPLYING SIDE LOADS TO THE BOOM OR BOOM EXTENSION IS MISUSE, IS HAZARDOUS, AND VOIDS WARRANTY.

CAUTION BOOM EXTENSION LOADS MUST NOT EXCEED MAIN BOOM CAPACITY. DO NOT PICK AND CARRY WITH LOADS ON BOOM EXTENSION. CAPACITIES ON OUTRIGGERS ARE 85% OF TIPPING LOADS. CAPACITIES ON RUBBER ARE 75% OF TIPPING LOADS. CAPACITIES BELOW BOLD LINE ARE LIMITED BY TIPPING. OTHER CAPACITIES ARE LIMITED BY STRUCTURAL OR HYDRAULIC CAPABILITY.

BOOM EXTENSION DEDUCT: 400 LBS. WHEN STOWED ON MAIN BOOM.

USE SINGLE PART LOAD LINE FOR LOADS TO 7500 LBS. (WT. 125 LBS.)



USE TWO PART LOAD LINE FOR LOADS TO 15000 LBS. (WT. 124 LBS.)



USE FOUR PART LOAD LINE FOR LOADS TO 30000 LBS. (WT. 210 LBS.)

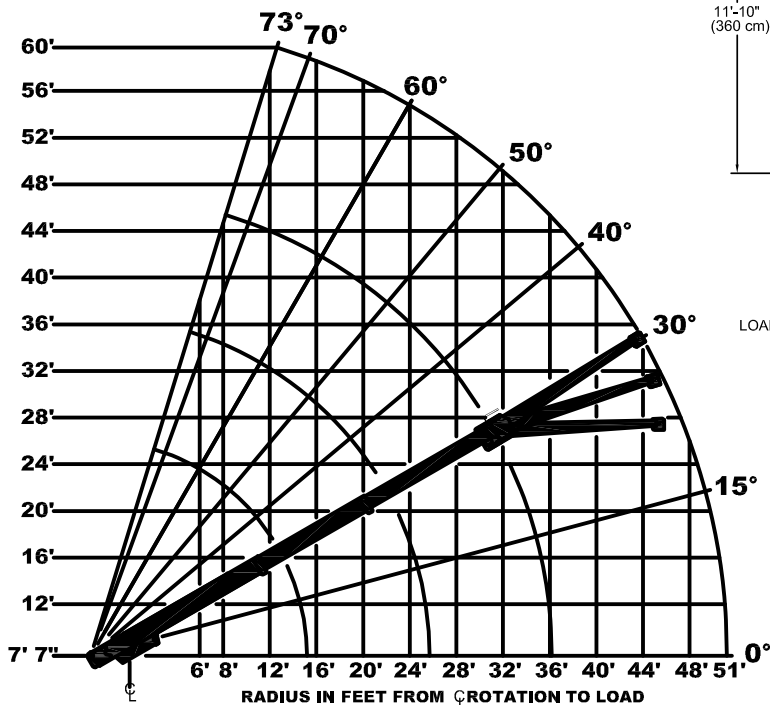

## IC-200-2H Chart

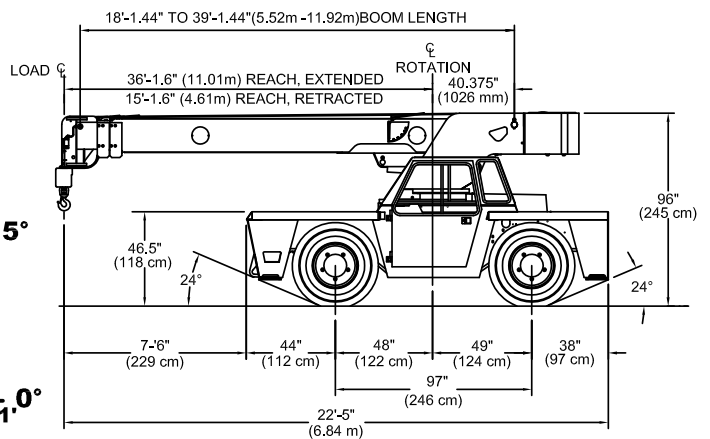
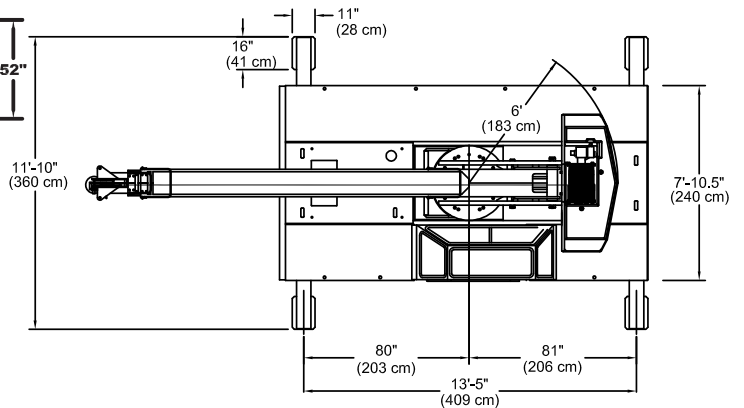
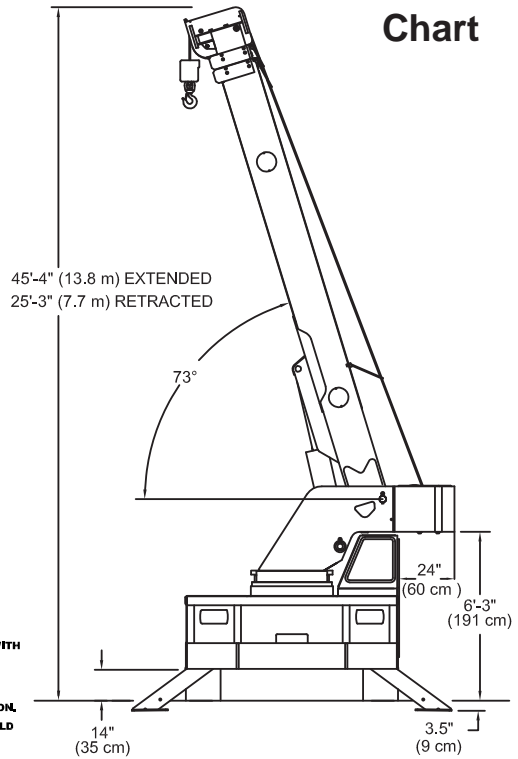

# IC-200-3H

| LOAD RADIUS FEET | CAPACITIES IN POUNDS FOR OPERATION ON FIRM LEVEL SURFACE |       |               |       |                |       |               |       |
|------------------|--|-------|---------------|-------|----------------|-------|---------------|-------|
|                  | MAIN BOOM ONLY   |       |               |       | BOOM EXTENSION |       |               |       |
|                  | ON RUBBER  |       | ON OUTRIGGERS |       | ON RUBBER      |       | ON OUTRIGGERS |       |
|                  | 360°   | FRONT | 360°          | FRONT | 360°           | FRONT | 360°          | FRONT |
| 6                | 16000  | 16400 | 30000         | 30000 | ---            | ---   | ---           | ---   |
| 8                | 12500  | 13000 | 22400         | 22400 | ---            | ---   | ---           | ---   |
| 10               | 10000  | 10500 | 18500         | 18500 | 7500           | 7500  | 7500          | 7500  |
| 12               | 8050   | 8700  | 15700         | 15700 | 7500           | 7500  | 7500          | 7500  |
| 14               | 6500   | 7200  | 13500         | 13500 | 7500           | 7500  | 7500          | 7500  |
| 16               | 5300   | 6200  | 10800         | 10800 | 6150           | 7500  | 7500          | 7500  |
| 18               | 4450   | 5400  | 9550          | 9550  | 5000           | 6450  | 7500          | 7500  |
| 20               | 3700   | 4700  | 8550          | 8550  | 4200           | 5400  | 7500          | 7500  |
| 22               | 3150   | 4200  | 7700          | 7700  | 3550           | 4650  | 6850          | 6850  |
| 24               | 2650   | 3700  | 6950          | 6950  | 3050           | 4000  | 6250          | 6250  |
| 26               | 2300   | 3200  | 6300          | 6350  | 2650           | 3500  | 5750          | 5750  |
| 28               | 1950   | 2800  | 5550          | 5800  | 2300           | 3100  | 5300          | 5300  |
| 30               | 1700   | 2450  | 4800          | 5300  | 2000           | 2700  | 4900          | 4900  |
| 32               | 1450   | 2150  | 4200          | 4900  | 1700           | 2400  | 4550          | 4550  |
| 34               | 1250   | 1850  | 3700          | 4500  | 1500           | 2100  | 4250          | 4250  |
| 38               | 900  | 1300  | 2950          | 3850  | 1150           | 1650  | 3500          | 3750  |
| 42               | 650  | 950   | 2400          | 3350  | 850            | 1300  | 2950          | 3350  |
| 46               | 400  | 650   | 1850          | 2900  | 600            | 1050  | 2450          | 2950  |
| 50               | 0  | 550   | 1750          | 2500  | 400            | 800   | 2050          | 2600  |
| 54               | ---  | ---   | ---           | ---   | 0              | 600   | 1700          | 2300  |
| 58               | ---  | ---   | ---           | ---   | 0              | 400   | 1350          | 2000  |
| 62               | ---  | ---   | ---           | ---   | 0              | 300   | 1150          | 1750  |
| 66               | ---  | ---   | ---           | ---   | 0              | 0     | 900           | 1500  |

| BOOM EXT. ANGLE | BOOM EXTENSION - STRAIGHT OR OFFSET |      |      |      |      |      |      |  |
|-----------------|-------------------------------------|------|------|------|------|------|------|--|
|                 | MAIN BOOM ANGLE                     |      |      |      |      |      |      |  |
|                 | 0°                                  | 15°  | 30°  | 40°  | 50°  | 60°  | 70°  |  |
| 0°              | 3000                                | 3100 | 3450 | 3900 | 4650 | 6000 | 7500 |  |
| 15°             | ---                                 | 3000 | 3000 | 3000 | 3000 | 3700 | 5000 |  |
| 30°             | ---                                 | ---  | 2500 | 2500 | 2600 | 3100 | 3800 |  |

LOAD RADIUS IS THE HORIZONTAL DISTANCE FROM THE CENTER OF ROTATION OF THE UNLOADED CRANE TO THE VERTICAL LOAD LINE WITH THE LOAD APPLIED.

EXCEEDING CAPACITY RATINGS OR APPLYING SIDE LOADS TO THE BOOM OR BOOM EXTENSION IS MISUSE, IS HAZARDOUS, AND VOIDS WARRANTY.

CAUTION BOOM EXTENSION LOADS MUST NOT EXCEED MAIN BOOM CAPACITY. DO NOT PICK AND CARRY WITH LOADS ON BOOM EXTENSION. CAPACITIES ON OUTRIGGERS ARE 85% OF TIPPING LOADS. CAPACITIES ON RUBBER ARE 75% OF TIPPING LOADS. CAPACITIES BELOW BOLD LINE ARE LIMITED BY TIPPING. OTHER CAPACITIES ARE LIMITED BY STRUCTURAL OR HYDRAULIC CAPABILITY.

BOOM EXTENSION DEDUCT: 400 LBS. WHEN STOWED ON MAIN BOOM.

## IC-200-3H Chart

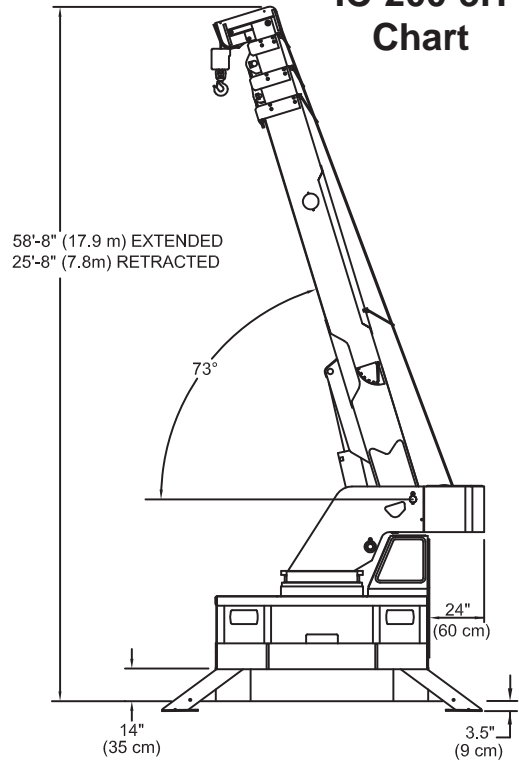

USE SINGLE PART LOAD LINE FOR LOADS TO 7500 LBS. (WT. 125 LBS.)



USE TWO PART LOAD LINE FOR LOADS TO 15000 LBS. (WT. 200 LBS.)



USE FOUR PART LOAD LINE FOR LOADS TO 30000 LBS. (WT. 210 LBS.)

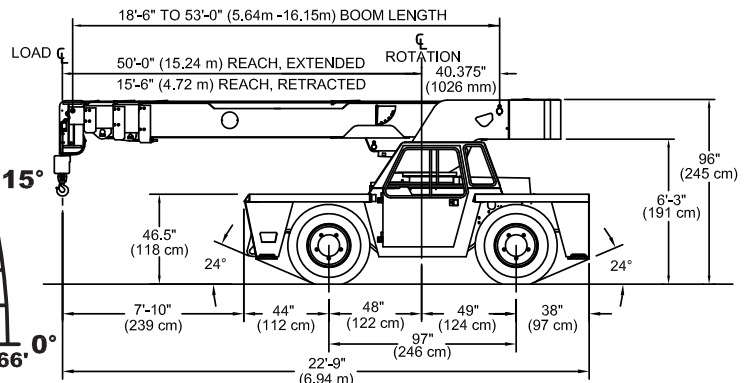
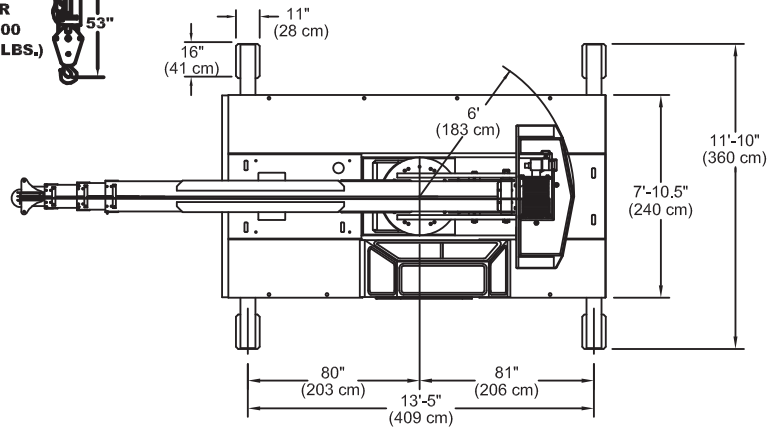
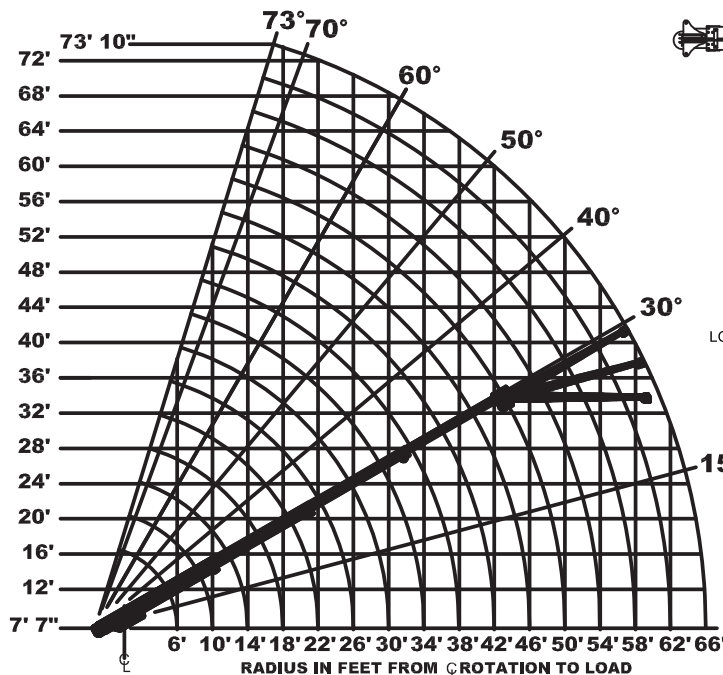

# IC-200-H

## Specifications

### GENERAL:

|                        |   |   |
|------------------------|---|---|
| <b>Weight:</b>         | <b>IC-200-2H</b><br>28,500 lbs<br>(12,940 kg) | <b>IC-200-3H</b><br>31,080 lbs<br>(14,110 kg) |
| <b>Boom Movement:</b>  |   |   |
| <b>Rotation</b>        | Continuous                                    | Continuous                                    |
| <b>Elevation</b>       | 0° to 73°                                     | 0° to 73°                                     |
| <b>Extension</b>       | 21' 0" (6.4m)                                 | 34' 6" (10.5m)                                |
| <b>Boom Speeds:</b>    |   |   |
| <b>Rotation</b>        | 1.9 RPM                                       | 1.8 RPM                                       |
| <b>Elevation</b>       | 20 sec.                                       | 20 sec.                                       |
| <b>Extension</b>       | 36 sec.                                       | 55 sec.                                       |
| <b>Gradeability:</b>   | 54% (28 Degrees)                              |   |
| <b>Turning Radius:</b> | 14' 5" (4.42m)                                |   |

### ENGINE:

|                           |                   |                  |
|---------------------------|-------------------|------------------|
|                           | <b>Standard</b>   | <b>Optional</b>  |
| <b>Make</b>               | GM*               | Cummins**        |
| <b>Model</b>              | 4.3L V-6          | QSB3.3           |
| <b>Type</b>               | Gasoline          | Turbo-Diesel     |
| <b>No. Cyl.</b>           | 6                 | 4                |
| <b>Displacement</b>       | 262 CID (4.3L)    | 199 CID (3.3L)   |
| <b>HP @ Gov. Speed</b>    | 93 H.P. (69 kW)   | 100 H.P. (75 kW) |
| <b>Fuel Tank Capacity</b> | 30 Gallons (113L) |                  |

\*Electronic Fuel Injection with Dual Fuel & Engine Management System, US EPA Tier 2

\*\*Charge Air Cooled & Grid Heater US EPA Tier 4i Emissions Certified

### TRANSMISSION:

Powershift transmission with 4-speeds forward and reverse. Provides powershifts at any engine speed in any gear. All shifting is done with a single lever electrical control mounted on the steering column. Equipped with torque convertor and transmission oil cooler. Torque convertor has stall ratio of 2.2:1.

|                    |        |        |        |
|--------------------|--------|--------|--------|
| <b>Gear Ratio:</b> |        |        |        |
| First              | 5.72:1 | Second | 3.23:1 |
| Third              | 1.77:1 | Fourth | 1.00:1 |

### AXLES:

#### Front Axle:

Planetary drive/steer front axle with 15.78 to 1.0 ratio. Differential equipped with "limited slip" feature. Front axle mounted rigidly to frame.

|             |                     |                      |
|-------------|---------------------|----------------------|
| <b>Gear</b> | <b>Travel Speed</b> | <b>Drawbar Pull*</b> |
| First       | 3 MPH               | 17,000*              |
| Second      | 5 MPH               | 8,900*               |
| Third       | 10 MPH              | 5,100*               |
| Fourth      | 18 MPH              | 2,700*               |

\*Drawbar pull is calculated for GM 4.3L engine.

#### Rear Axle:

##### Standard (2-Wheel Drive):

Steering axle with 1-1/2 degree oscillation in either direction.

##### Optional (4-Wheel Drive):

Planetary drive/steer axle with 24.98 to 1.0 ratio. Differential is not "limited slip" in rear axle. 1-1/2 degree oscillation in either direction. Axle ratio compatible with 4-wheel drive transmission output for front axle match. Transmission equipped with electrohydraulic control for shifting between 2-wheel drive and 4-wheel drive.

### STEERING:

Full hydraulic steering unit with two 3-inch (7.6 cm) cylinders attached to each axle. Allows limited steering when engine is not running. A switch on the control panel is used to select rear-wheel steering, four-wheel steering or crab steering. Electronic sensors and control box automatically align the steering when a new mode is selected.

### BRAKES:

**Service:** Split-system, 4-wheel hydraulic-boosted multiple-plate wet disc brakes.

**Parking:** Hand lever actuated disc-type parking brake on transmission.

**TIRES:** 15x22.5, 16-ply rating.

### OPERATOR COMPARTMENT:

Provides one-position access to all chassis and crane functions. Includes adjustable operator's seat, retracting seat belts, fire extinguisher and bubble level.

### CHASSIS:

#### Cargo Deck:

66 square feet (6 m<sup>2</sup>) of deck area. 17,000 lbs (7,700 kg) capacity on deck when load is centered over or between axles. Steps located on front corners.

#### Lifting Rings:

Lifting rings at each corner of load deck so sling can be attached for lifting crane.

#### Outriggers:

Four hydraulic outriggers of box beam construction with direct-connected holding valves. Independent controls for each outrigger. Outrigger pad dimension: 11" x 16" (28cm x 41cm).

#### Accessory Storage Box:

Storage box is 14" (35cm) deep x 10-1/2" (26cm) long x 36-1/2" (93cm) wide, located in front cargo deck.

### ELECTRICAL:

#### 12 Volt System

##### Lighting Package:

One pair headlights with high and low beams, tail, brake and turn signal lights and back-up lights in rear, front turn signals and emergency flasher switch at operator's station.

##### Instrument Package:

Fuel gauge and hourmeter records hours only during actual engine operations. Also includes warning lights for low oil and transmission pressure, check engine, high coolant and transmission temperature, turn signals, high beams, hazard lights, parking brake and four-wheel drive.

##### Back-Up Alarm:

Provides pulsating sound when transmission is in reverse.

##### Outrigger Alarm System:

Two-tone alarm is activated when "outrigger down" controls are operated.

### HYDRAULIC SYSTEM:

Tandem pump, direct-driven by engine crankshaft, rated at 29 GPM (110 L/min) and 34 GPM (129 L/min) at rated RPM. Hydraulic oil tank capacity of 54 gallons (204 L).

### BOOM ASSEMBLY:

Three or four section boom assembly equipped with bearing pads, double-acting hydraulic cylinders with direct-connected holding valves and boom angle indicator on each side of boom.

### Boom Rotation:

Heavy-duty ball bearing rotation gear with external teeth. Rotation is powered by hydraulic motor and worm gear drive.

### Boom Hoist:

Turret mounted planetary gear hoist hydraulically powered with a baredrum line pull of 10,000 lbs. (4536 kg) at a line speed of 100 FPM (30 m/min). Includes downhaul weight, swivel hook and sheave block for 4-part line and 240 ft (73m) (2H) and 291 ft (89m) (3H) of 1/2" (13mm) hoist rope.

### Anti-Two-Block Device:

Prevents damage to hoist rope and/or crane components from pulling load hook against tip.

### Sheave Block, Four Part Line:

Double sheave block for 4-part line requirements.

### Rated Capacity Limiter:

Warns operator of impending overload with audible and visual signals. Prevents overloads by stopping boom functions that cause overloads.

# IC-200-H

## Options

Listed below are brief descriptions of options available for this product.  
Consult the IC-200-H Engineering Spec for additional information.

### MODEL:

**IC-200-2H Industrial Crane** with  
15' 2"-36' 2" (4.6 m-11m) Boom

**IC-200-3H Industrial Crane** with  
15' 6"-50' 0" (4.7m-15.2m) Boom

### ENGINE OPTIONS:

#### Diesel Engine

Cummins QSB3.3 Turbo, Tier 4i

#### Spark Arrester Muffler

Installed in addition to standard muffler.

#### Engine Heater

Engine coolant heater installed to circulate warm water through engine, plugs into 120 volt AC.

### AXLE & STEERING OPTIONS:

**4-Wheel Steer & 2-Wheel Drive**

**4-Wheel Steer & 4-Wheel Drive**

### TIRE OPTIONS:

**Non-Marking Tires**

**Foam Filling of Tires**

**Spare Tire & Wheel**

### CHASSIS OPTIONS:

#### Auxiliary Winch

Mounted behind front bumper, hydraulically driven with control in operator's console.

#### Pintle Hook:

**Pintle Hook, Rear**

**Pintle Hook, Front**

#### Headlight and Taillight Grilles

Welded steel protective grilles for headlights and taillights.

#### Rearview Mirrors

One mounted on right-hand deck stake and one mounted on left-hand deck stake.

### OPERATOR COMPARTMENT OPTIONS:

#### Operator Guard

Tubular steel weldment with heavy expanded steel mesh top section.

#### Operator Guard Cover

Clear vinyl cover over Operator Guard, for inclement weather operations.

#### All Weather Cab

Rigid-mounted canopy section and removable hinged door. Includes heater, electric wind-shield wiper, one sliding glass window in the door and one in the right side of canopy. Defroster fan and dome light included.

#### Cab Heater Only

Heater with two-speed fan for units without All Weather Cab.

#### Windshield Washer

Includes reservoir, pump & nozzle.

#### Floor Mat

Vinyl mat with foam backing.

#### Operator Suspension Seat

Provides additional comfort for operator.

#### Noise Reduction Kit

Includes floor mat, control valve cover and side panels of foam backed vinyl for noise reduction.

#### Air Conditioning

Air Conditioner w/134 coolant.

### ELECTRICAL OPTIONS:

#### Strobe Lights

Yellow strobe light mounted on each side of turret weight box.

#### Boom Work Lights

One work light mounted to boom to light boom tip and one work light mounted to turret to light ground under boom tip.

#### Work Lights - Rear

Two work lights recessed in rear bumper.

### BOOM ATTACHMENTS:

#### Boom Extension, 15 Ft. (4.6m) (2H Only)

Swing away and boom stowable.

#### Boom Extension, 15 Ft. (4.6m), Offsettable (2H Only)

Same as above except the boom extension is offsettable to 3 different positions; 0 degree (inline), 15 degree and 30 degree offset.

#### Boom Extension, 16 Ft. (5m), Offsettable (3H Only)

Same as above except the boom extension is 16 ft (5m).

#### Sheave Block - Two-Part Line Searcher Hook:

Nose Mount 5,000 pound (2,268 kg) capacity hook bracket.

Should you require an option or special equipment not listed please consult your dealer salesperson or BMC®.

**BRODERSON®**

Manufacturing Corp.

14741 West 106th Street

Lenexa, KS 66215 USA

Tel (913) 888-0606

Fax (913) 888-8431

www.bmccranes.com

Dimensions and values shown are  
for reference purposes only.

Specifications subject to change.

