

Technical Data

Specifications & Capacities

RTC 8040

Series II
Telescopic Boom Rough Terrain Crane
40 ton (40.00 metric ton)

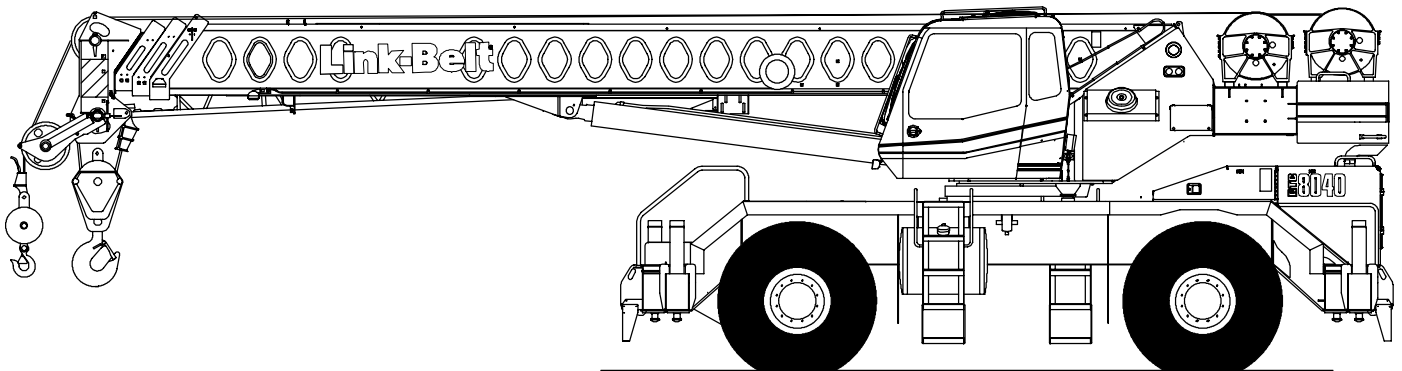

CAUTION: This material is supplied for reference use only. Operator must refer to in-cab Crane Rating Manual and Operator's Manual to determine allowable crane lifting capacities and assembly and operating procedures.

Table Of Contents

Boom, Attachments, and Upper Structure	1
Boom	1
Boom Head	1
Boom Elevation	1
Auxiliary Lifting Sheave – Optional	1
Hook Blocks and Balls – Optional	1
Fly – Optional	1
Operator’s Cab and Controls	1
Swing	2
Electrical	2
Load Hoist System	3
Load Hoist Performance	3
2M Main and Optional Auxiliary Winches	3
Hydraulic System	3
Counterweight	3
Carrier	4
General	4
Outriggers	4
Steering and Axles	4
Suspension	4
Tires and Wheels	4
Brakes	4
Electrical	4
Engine	4
Transmission	4
Carrier Speeds and Gradeability	5
Fuel Tank	5
Hydraulic System	5
Pump Drive	5
Axle Loads	6
General Dimensions	7
Working Range Diagram	8
Boom Extend Modes	9
Main Boom Lift Capacity Charts – Standard	10
Fully Extended Outriggers – 360° Rotation	10
On Tires – Stationary – Boom Centered Over Front Between Tire Tracks	11
On Tires – Pick & Carry (Creep) – Boom Centered Over Front	11
On Tires – Stationary – 360° Rotation	11
Fly Attachment Lift Capacity Charts – Optional	12
Fully Extended Outriggers – 360° Rotation	12
105 ft Main Boom Length – 2° Fly Offset	12
105 ft Main Boom Length – 20° Fly Offset	12
105 ft Main Boom Length – 40° Fly Offset	12

Main Boom Lift Capacity Charts – Optional (Metric)	13
Fully Extended Outriggers – 360° Rotation	13
On Tires – Stationary – Boom Centered Over Front Between Tire Tracks	14
On Tires – Pick & Carry (Creep) – Boom Centered Over Front	14
On Tires – Stationary – 360° Rotation	15
Fly Attachment Lift Capacity Charts – Optional (Metric)	15
Fully Extended Outriggers – 360° Rotation	15
33.53m Main Boom Length – 2° Fly Offset	15
33.53m Main Boom Length – 20° Fly Offset	15
33.53m Main Boom Length – 40° Fly Offset	15

Boom, Attachments, and Upper Structure

■ Boom

Design – Four section, box type construction of high tensile steel consisting of one base section and three telescoping sections. The vertical side plates have diamond shaped steel impressions for superior strength to weight ration. The first telescoping section extends independently by means of one double-acting, single stage hydraulic cylinder with integrated holding valves. The second and third telescoping sections extend proportionally by means of one double-acting, single stage cylinder with integrated holding valves and cables.

Boom

- 33 ft 6 in – 105 ft (10.0–32.0m) four section full power boom
- Two mode boom extension: *A-max* mode provides superior capacities by extending the first telescoping section to 57 ft (17.4m). Standard mode synchronizes all the telescoping sections proportionally to 105 ft (32.0m). Controlled from the operator's cab.
- Mechanical boom angle indicator
- Maximum tip height for *A-max* mode is 66 ft 2 in (20.2m) and standard mode is 113 ft 6 in (34.6m).

Boom Head

- Four 16.5 in (41.9cm) root diameter nylon sheaves to handle up to eight parts of line
- Easily removable wire rope guards
- Rope dead end lugs on each side of the boom head
- Boom head is designed for quick-reeve of the hook block

Boom Elevation

- One double acting hydraulic cylinder with integral holding valve
- Boom elevation: -3° to 78°

Auxiliary Lifting Sheave – Optional

- Single 16.5 in (41.9m) root diameter nylon sheave
- Easily removable wire rope guards
- Does not affect erection of the fly or use of the main head sheaves

Hook Blocks and Balls – Optional

- 40 ton (36.3mt) 4 sheave quick-reeve hook block with safety latch
- 8.5 ton (7.7mt) swivel and non-swivel hook balls with safety latch

Fly – Optional

- 28 ft 6 in (8.7m) one piece lattice fly, stowable, offsettable to 2° , 20° , and 40° . Maximum tip height is 141 ft (43.0m).
- 28 ft 6 in – 51 ft (8.7–15.5m) two piece bi-fold lattice fly, stowable, offsettable to 2° , 20° , and 40° . Maximum tip height is 163 ft (49.7m).

■ Operator's Cab and Controls

Environmental Cab – Fully enclosed, one person cab of galvaneal steel structure with acoustical insulation.

Equipped with:

- Tinted and tempered glass windows
- Extra-large fixed front window with windshield wiper and washer
- Swing up roof window with windshield wiper
- Sliding left side door with large fixed window
- Sliding rear and right side windows for ventilation
- Six way adjustable, cushioned seat with seat belt and storage compartment
- Engine dependent warm-water heater with air ducts for front windshield defroster and cab floor
- Defroster fan for the front window
- Bubble level
- Circulating fan
- Adjustable sun visor
- Dome light
- Cup holder
- Fire extinguisher
- Left side viewing mirror
- Two position travel swing lock

Air Conditioning – Optional – Integral with cab heating system utilizing the same ventilation outlets

Steering Column – Pedestal type with tilt and telescope functions for operator comfort. Column includes the following controls and indicators:

Left and right levers include:

- Horn button
 - Turn signal switch
 - Driving light switch
 - Transmission direction switch
- Panel mounted switches for:
- Travel park brake
 - Steer mode selector
 - 4 wheel drive
 - Transmission gear selector
 - Ether start
 - Hazard flasher
- Panel mounted indicator/warning lights for:
- Transmission display
 - Transmission temperature
 - Engine oil pressure
 - Travel park brake
 - Service brake
 - Turn signals
 - Rear wheel offset – optional
 - Emergency steer – optional

Armrest Controls – Two dual axis hydraulic joystick controllers or optional single axis hydraulic controllers for:

- Swing
- Boom hoist
- Main rear winch
- Auxiliary front winch – optional
- Drum rotation indication
- Drum rotation indicator activation switch
- Winch high/low speed and disable switch(es)
- Third wrap selector switch – optional
- Telescopic override switches
- Warning horn button

Outrigger Controls – Hand held control box with umbilical cord gives the operator the freedom to view operation while setting the outriggers.

Foot Controls

- Boom telescope
- Swing brake
- Engine throttle

Right Front Console – Controls and indicators for:

- | | |
|-------------------------------------|---|
| • Engine ignition | • Console dimmer switch |
| • Engine throttle lock | • Bubble level |
| • Function disable | • 12 volt power connection |
| • Swing park brake | • Air conditioning – optional |
| • Front windshield wiper and washer | • Boom floodlight – optional |
| • Cab floodlights | • Rotating beacon/Strobe light – optional |
| • Warning horn | • Third wrap indicator – optional |
| • Heating controls | |

Cab Instrumentation – Ergonomically positioned, analog instrumentation for crane operation including:

- Engine coolant temperature with warning indicator
- Hydraulic oil temperature with warning indicator
- Fuel level with warning indicator
- Tachometer

Rated Capacity Limiter – Microguard 434 graphic audio–visual warning system integrated into the dash with anti–two block and function limiter. Operating data available includes:

- Crane configuration
- Boom length and angle
- Boom head height
- Allowed load and % of allowed load
- Boom angle
- Radius of load
- Actual load
- Operator settable alarms (include):
 - Maximum and minimum boom angles
 - Maximum tip height
 - Maximum boom length
 - Swing left/right positions
 - Operator defined area (imaginary plane)

Internal RCL Light Bar – Optional – Visually informs the operator when crane is approaching maximum load capacity with a series of green, yellow, and red lights.

External RCL Light Bar – Optional – Visually informs the ground crew when crane is approaching maximum load capacity with a series of green, yellow, and red lights.

■ Swing

Motor/Planetary – Bi–directional hydraulic swing motor mounted to a planetary reducer for 360° continuous smooth swing at 2.5 rpm.

Swing Park Brake – 360°, electric over hydraulic, (spring applied/hydraulic released) multi–disc brake mounted on the speed reducer. Operated by a switch from the operator’s cab.

Swing Brake – 360°, foot operated, hydraulic applied disc brake mounted to the speed reducer.

Swing Lock – Two–position swing lock (boom over front or rear) operated from the operator’s cab.

360° Positive Swing Lock – Optional – Meets New York City requirement.

■ Electrical

Swing Alarm – Audio warning device signals when the upper is swinging.

Lights

- Two working lights on front of the cab
- One rotating amber beacon on top of the cab – optional
- One amber strobe beacon on top of the cab – optional
- Boom floodlight – optional

■ Load Hoist System

Load Hoist Performance

Main (Rear) and Auxiliary (Front) Winches – 3/4 in (19mm) Rope										
Layer	Maximum Line Pull		Normal Line Speed		High Line Speed		Layer		Total	
	lb	kg	ft/min	m/min	ft/min	m/min	ft	m	ft	m
1	15,390	6 980.8	168	51.2	337	102.7	114	34.7	114	34.7
2	14,150	6 418.3	183	55.8	366	111.6	124	37.8	238	72.5
3	13,094	5 939.3	198	60.4	396	120.7	134	40.8	372	113.4
4	12,185	5 527.0	212	64.6	425	129.5	144	43.9	516	157.3
5	11,394	5 168.2	227	69.2	455	138.7	154	46.9	670	204.2

Wire Rope Application		Diameter		Type	Maximum Permissible Load	
		in	mm		lb	kg
Main (Rear) Winch	Standard	3/4	19	18x19 rotation resistant – right regular lay (Type RB)	12,920	5 860.5
	Optional	3/4	19	36x7 rotation resistant – right regular lay (Type ZB)	15,600	7 076.2
Auxiliary (Front) Winch	Standard	3/4	19	18x19 rotation resistant – right regular lay (Type RB)	12,920	5 860.5
	Optional	3/4	19	36x7 rotation resistant – right regular lay (Type ZB)	15,600	7 076.2

2M Main and Optional Auxiliary Winches

- Bi-directional gear-type (2-speed) hydraulic motors driven through planetary reduction unit for positive control under all load conditions.
- Grooved lagging
- Power up/down mode of operation
- Hoist drum cable follower
- Drum rotation indicator
- Drum diameter: 16 in (40.6cm)
- Rope length:
 - Main: 600 ft (182.9m)
 - Auxiliary: 600 ft (182.9m)
- Maximum rope storage: 834 ft (254.2m)
- Terminator style socket and wedge

Third wrap indicator – optional – Visually and audibly warns the operator when the wire rope is on the first/bottom layer and when the wire rope is down to the last three wraps.

■ Hydraulic System

Counterbalance Valves – All hoist motors, boom extend cylinders, and boom hoist cylinders are equipped with counterbalance valves to provide load lowering and prevents accidental load drop when hydraulic power is suddenly reduced.

■ Counterweight

Total of 10,100 lb (4 581kg) of counterweight bolted to the upper structure frame with capacities for the 10,100 lb (4 581kg) configuration.

Carrier

General

- 10 ft 10.5 in (3.31m) wide
- 12 ft 7 in (3.83m) wheelbase (centerline of first axle to centerline of second axle).

Frame – Box–type, torsion resistant, welded construction made of high tensile steel. Equipped with front and rear towing and tie–down lugs, tow connections, and access ladders.

Outriggers

Boxes – Two double box, front and rear welded to carrier frame.

Beams and Jacks – Four single stage beams with Confined Area Lifting Capacities (CALC™) provide selectable outrigger extensions of full, intermediate, and retracted. Hydraulically controlled from the operator's cab with integral check valves.

Pontoons – Four lightweight, quick release, 23.50 x 27.25 in (59.69 x 69.22cm), hexagonal steel pontoons with contact area of 485 in² (3 129cm²) can be stored for road travel in storage racks on the carrier.

Main Jack Reaction – 94,800 lb (43 000.6kg) force and 196 psi (1 351.4kPa) ground bearing pressure.

Steering and Axles

Steering – Four independent modes consisting of two wheel front, two wheel rear, four wheel, and crab. Each mode is controlled from the steering wheel and is selected by a switch in the operator's cab.

Drive – Two modes: 4 x 2 and 4 x 4 for off highway travel

Axle 1 – Steered, non–driven for 4 x 2 and steered, driven for 4 x 4

Axle 2 – Steered, driven

Suspension

Front – Rigid mount to the carrier frame

Rear – The rear axle is suspended on the oscillation cylinders with motion of the axle controlled by a four bar linkage system. The oscillation cylinders lockout when the upper structure rotates 2.5° past centerline.

- Hydro–gas rear suspension – optional

Tires and Wheels

Front and Rear – Four (single) 23.5 x 25–20 ply rating, earthmover type tires on steel disc wheels

- Spare tires and wheels – optional

Brakes

Service – Full hydraulic, dual circuit, disc type brakes on all wheel ends

Parking/Emergency – Spring loaded type, acting on front axle

Electrical

Three batteries provide 12 volt operation and starting

Lights

- Front lighting includes two main headlights, and two parking/directional indicators.
- Side lighting includes two parking/directional indicators per side.
- Rear lighting includes two parking/directional indicators, two parking/brake lights, and two reversing lights.
- Other equipment includes hazard/warning system, cab light, instrument panel light, and signal horn.

Engine

Specification	Cummins 6BT 5.9L
Numbers of Cylinders	6
Cycle	4
Bore and Stroke: inch (mm)	4.02 x 4.72 (102 x 120)
Piston Displacement: in ³ (L)	359 (5.9)
Max. Brake Horsepower: hp (kW)	165 (123) @ 2,500 rpm
Peak Torque: ft lb (J)	440 (597) @ 1,500 rpm
Alternator: volts – amps	12 – 130
Crankcase Capacity: qt (L)	17.2 (16.3)
<ul style="list-style-type: none"> • Mechanically driven fan and thermostatically controlled radiator • Water/Fuel separator • 110–volt block heater • Ether injection package – optional 	

Transmission

Powershift – Fully automatic transmission with eight speeds forward and four reverse. Rear axle disconnect for two or four wheel drive. Rear axle disconnects automatically in forward fifth and higher gears.

Carrier Speeds and Gradeability

Funk		Speed			Gradeability (@ 70% Convertor efficiency)
Gear		Ratio	mph	km/h	% Grade
8th	Forward 2WD	0.74	25.7	41.3	3.3
7th		1.03	18.4	29.6	5.5
6th		1.45	13.1	21.0	8.5
5th		2.03	9.3	15.0	12.8
4th	Forward 2WD or 4WD	2.90	6.5	10.5	19.4
3rd		4.05	4.7	7.5	28.4
2nd		5.72	3.3	5.3	42.9
1st		7.99	2.4	3.8	67.4
4th	Reverse 2WD or 4WD	1.03	18.4	29.6	5.5
3rd		2.03	9.3	15.0	12.8
2nd		4.05	4.7	7.5	28.4
1st		7.99	2.4	3.8	67.4

Based on a gross vehicle weight of 80,000 lb (36 287kg).
Crane operating angle must not exceed 35° (77% grade).

Fuel Tank

One 75 gallon (283.9L) capacity tank

Hydraulic System

All functions are hydraulically powered allowing positive precise, control with independent or simultaneous operation of all functions.

Main Pumps

- Three fixed displacement gear pumps for the main and auxiliary winches, swing, boom hoist, and telescope circuits with a manual disconnect to aid during cold weather starts.
- One gear pump for the outriggers, power steering, brakes, and telescope circuits.
- One pressure compensated piston pump is used in the control, service brake, and counterweight removal circuits.
- Combined pump capacity of 139 gpm (526.2Lpm).

Hydraulic Reservoir – 131 gal (495.9L) capacity equipped with sight level gauge. Diffusers built in for deaeration.

Filtration – One 10 micron, full flow, line filter in the control circuit. All oil is filtered prior to return to sump tank. Accessible for easy filter replacement.

Pump Drive

All pumps are mechanically driven by the diesel engine. Main and auxiliary winches, swing, boom hoist, and telescope pumps are mounted to a mechanical pump disconnect on the transmission torque convertor to aid in cold weather starting.

Axle Loads

Base crane with full tank of fuel	Gross Vehicle Weight ⁽¹⁾		Upper Facing Front				Upper Facing Rear			
			Front Axles		Rear Axles		Front Axles		Rear Axles	
	lb	kg	lb	kg	lb	kg	lb	kg	lb	kg
	68,095	30 887	32,757	14 858	35,338	16 029	30,451	13 812	37,664	17 084
Cold weather starting aids – ether injection	6	3	-2	-1	8	4	-2	-1	8	4
Pintle hook, front	13	6	18	8	-5	-2	18	8	-5	-2
Pintle hook, rear	13	6	-5	-2	18	8	-5	-2	18	8
Rear steer indicator	3	1	0	0	3	1	0	0	3	1
Hydro-gas suspension	52	24	19	9	34	15	19	9	34	15
Add 23.5R25 tires	368	167	183	83	185	84	183	83	185	185
Winch roller – rear winch	93	42	-39	-18	132	60	129	59	-36	-17
Winch roller – front winch	93	42	-19	-9	112	51	109	49	-16	-7
2M auxiliary winch	19	9	-2	-1	21	10	21	10	-2	-1
600 ft (182.9m) of 3/4 in (19mm) wire rope on auxiliary winch	669	303	-88	-40	757	343	734	333	-65	-30
Air conditioning in operator's cab	315	143	74	34	241	109	231	105	84	38
360° swing lock	76	34	28	13	48	21	45	20	31	14
Emergency steer system	136	62	15	7	121	55	116	53	20	9
Fly storage brackets to boom base section for fly options	109	49	138	62	-29	-13	-33	-15	141	64
28.5 ft (8.68m) offset fly – stowed	1,184	537	1,836	833	-652	-296	-692	-314	1,876	851
28.5–51 ft (8.68–15.54m) offset fly – stowed	1,757	797	2,557	1 160	-800	-363	-860	-390	2,617	1 187
Floodlight to boom base section	10	5	21	10	-11	-5	-12	-5	22	10
40 ton (36.3mt) hook block to carrier storage box	720	327	994	451	-274	-124	-298	-135	1,108	462
8.5 ton (7.7mt) hook block to carrier storage box	360	163	497	225	-137	-62	-149	-68	509	231
Auxiliary lifting sheave	93	42	246	112	-153	-70	-156	-71	249	113

Tire	Maximum Load @ 25 mph (40.2km/h)
23.5 x 25 (20–PR)	38,800 lb (17 599kg)
23.5R25 2 Star	37,500 lb (17 010kg)

(1) Adjust gross vehicle weight and axle loading according to component weight.
 Note: All weights are ±3%.

General Dimensions

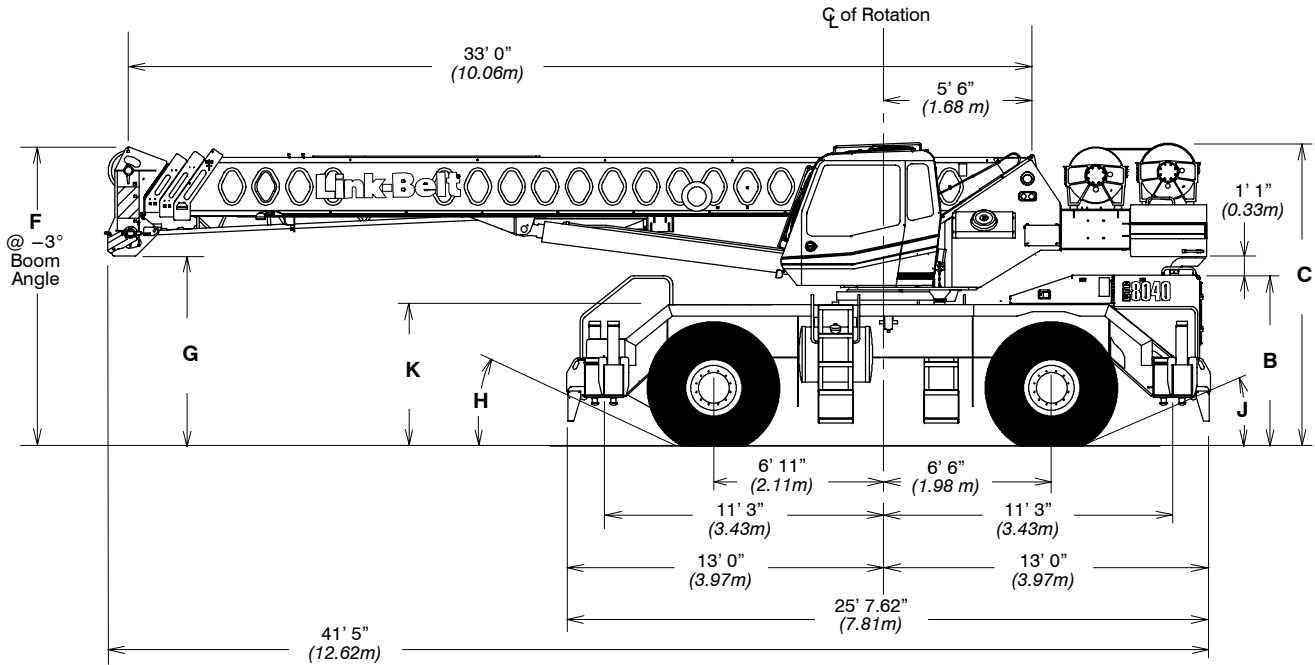

Turning Radius – Front Wheel (4x2) Steering		English	Metric
Wall to wall over carrier		39' 0"	11.9m
Wall to wall over boom		45' 7"	13.9m
Wall to wall over boom attachment		47' 8"	14.5m
Curb to curb		37' 3"	11.4m
Centerline of tire		36' 0"	11.0m

Turning Radius – All Wheel (4x4) Steering		English	Metric
Wall to wall over carrier		23' 4"	7.1m
Wall to wall over boom		33' 8"	10.3m
Wall to wall over boom attachment		33' 2"	10.1m
Curb to curb		21' 4"	6.5m
Centerline of tire		20' 0"	6.1m

Tail Swing		English	Metric
With counterweight		12' 8"	3.9m
Without counterweight		N/A	N/A

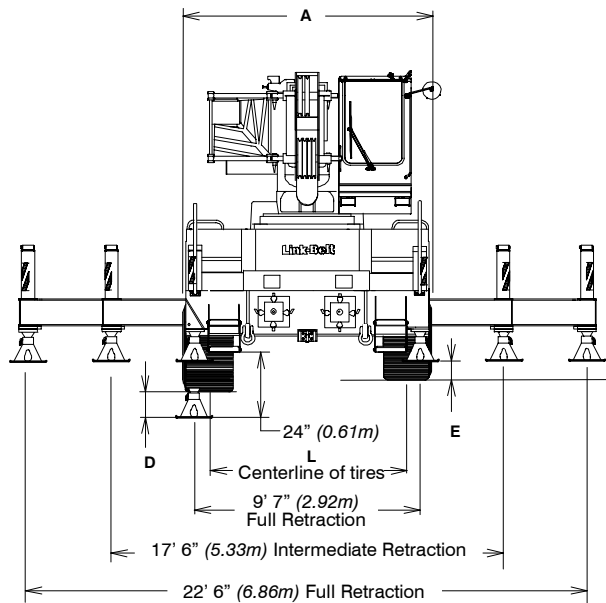

General Dimensions	Tire Size			
	23.5 x 25		23.5R25	
	English	Metric	English	Metric
A	10' 3.5"	3.14m	10' 3"	3.12m
B	6' 7.75"	2.03m	6' 9.5"	2.06m
C	11' 11.75"	3.65m	12' 1.5"	3.70m
D	7.75"	0.20m	7"	0.18m
E	10"	0.25m	11.75"	0.30m
F	10' 1.25"	3.08m	10' 3"	3.13m
G	7' 6"	2.29m	7' 7.75"	2.33m
H	24"	--	24.8"	--
J	21"	--	22"	--
K	6' 6.75"	1.69m	6' 8.5"	1.74m
L	8' 3"	2.51m	8' 3"	2.51m

Not To Scale

Working Range Diagram

Working Range Diagram On Fully Extended Outriggers

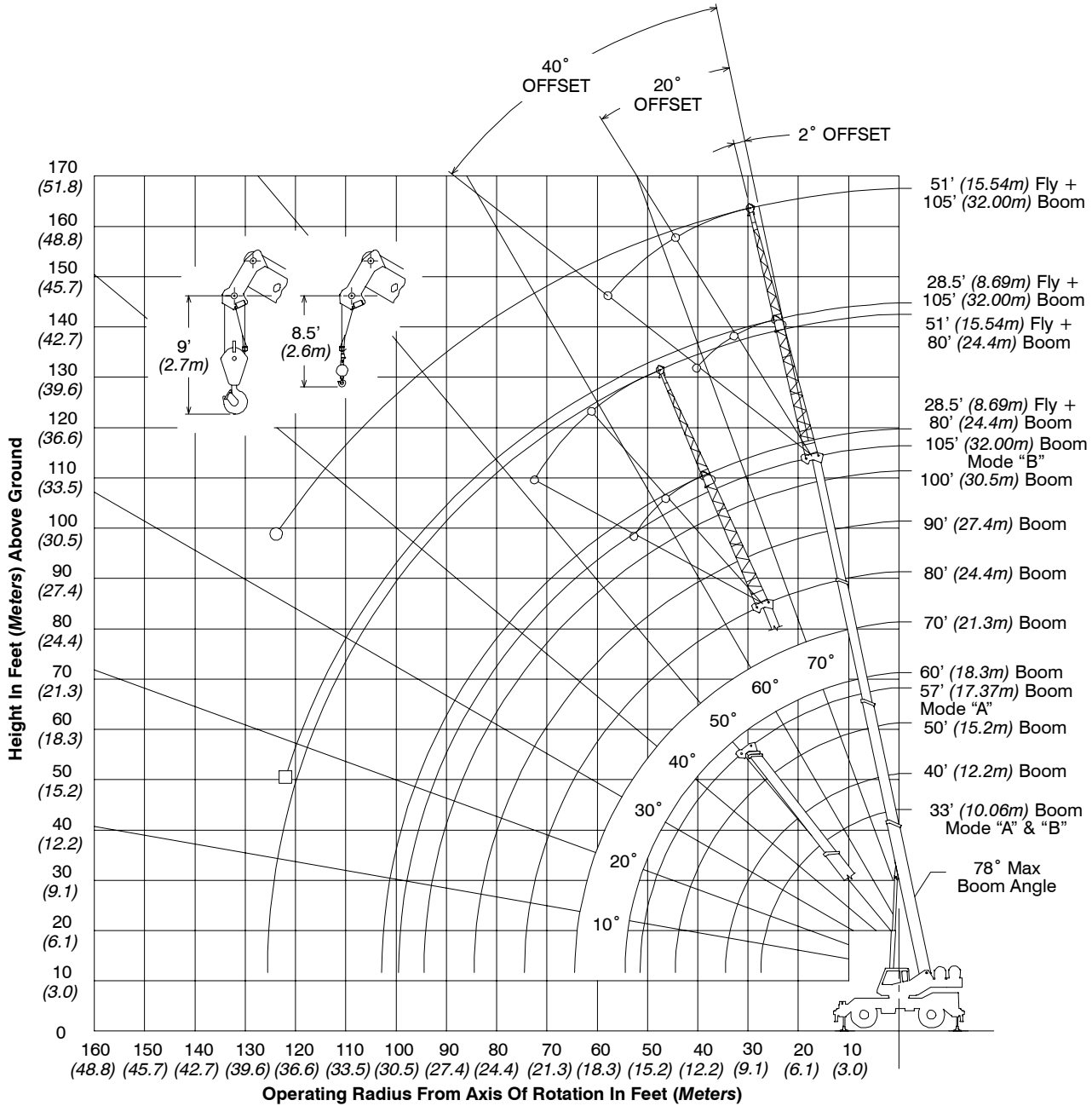
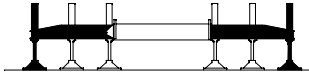

- Denotes Main Boom + 51' (15.5m) Fly-Boom Mode "B"
- Denotes Main Boom + 28.5' (8.7m) Fly-Boom Mode "B"

Boom Extend Modes

Boom Mode “A” (A-max)

Only inner mid section telescopes.

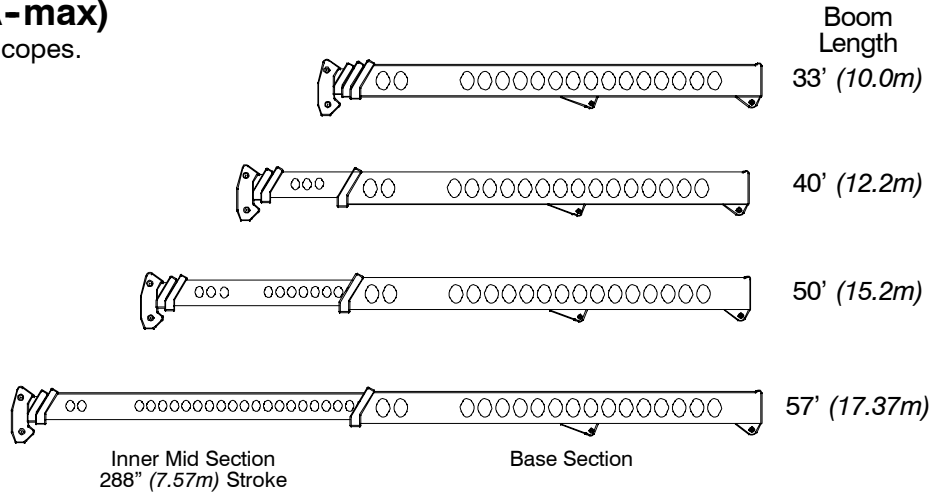

Boom Mode “B” (Standard)

Inner mid, outer mid, and tip sections telescope simultaneously.

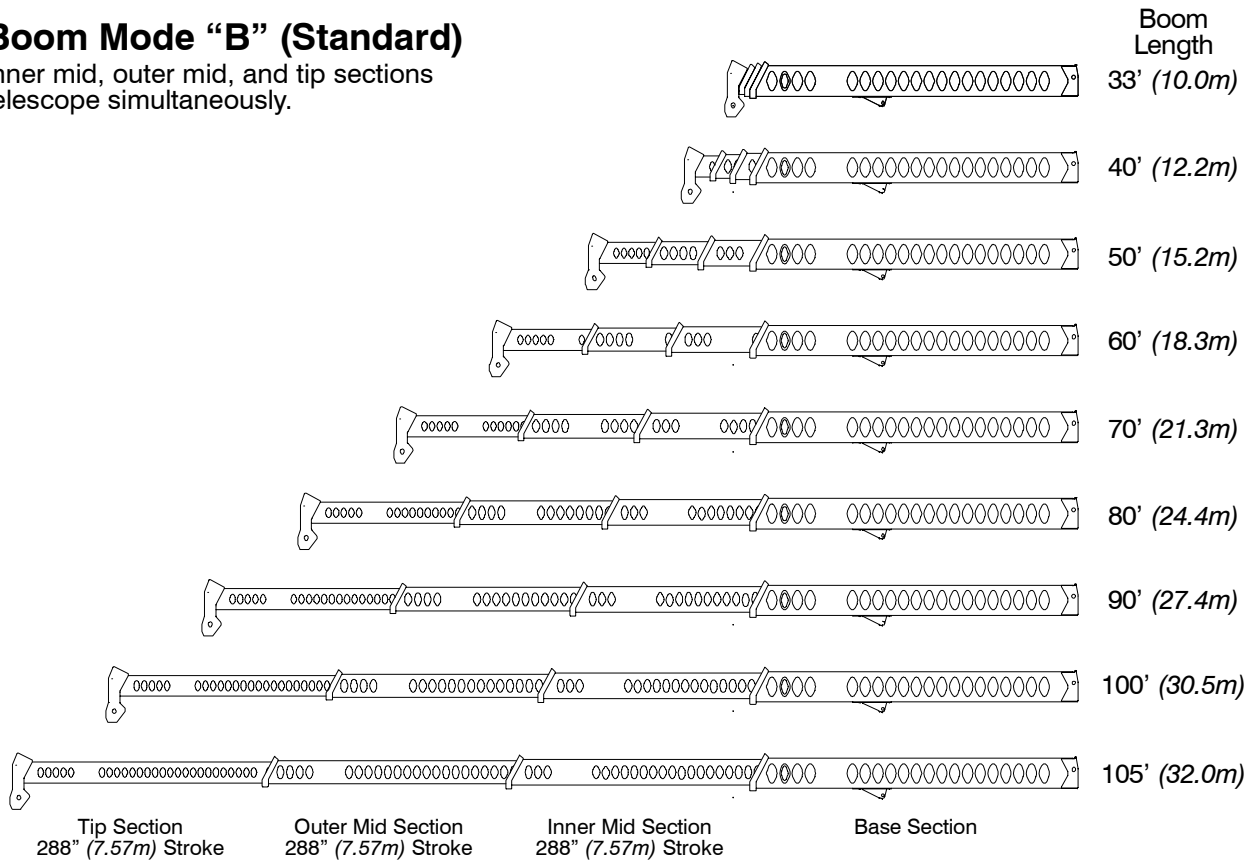

Main Boom Lift Capacity Charts – Standard

Fully Extended Outriggers – 360° Rotation (All Capacities Are Listed In Pounds)										
Radius (ft)	Boom Length (ft)									Radius (ft)
	33	40	50	57/60	70	80	90	100	105	
10	80,000	72,100	70,500	43,800**						10
12	73,800	72,100	65,600	43,800**						12
15	63,100	62,900	57,400	42,200**	35,000					15
20	47,300	47,100	46,800	35,000	35,000	30,500	27,100			20
25	36,100	35,900	35,700	35,000	35,000	26,300	23,400	20,900	17,500	25
30		29,200	29,800	30,100	30,300	22,900	20,400	18,600	17,500	30
35			24,400	24,800	25,000	20,200	18,000	16,200	15,700	35
40			19,500	19,800	19,900	18,000	16,000	14,500	13,900	40
45				15,900	16,100	16,200	14,300	13,000	12,200	45
50				13,100	13,200	13,400	13,000	11,700	10,700	50
55					11,100	11,200	11,300	10,600	9,500	55
60					9,300	9,500	9,600	9,600	8,400	60
65						8,000	8,100	8,200	7,500	65
70						6,800	7,000	7,000	6,800	70
75							6,000	6,000	6,000	75
80							5,100	5,200	5,200	80
85								4,400	4,500	85
90								3,800	3,800	90
95									3,200	95

* Special Conditions Or Wire Rope Required
** 57.0 A – max Mode

This information is not for crane operation. Operator must refer to the in-cab information for crane operation. Rated lifting capacities shown on fully extended outriggers do not exceed 85% of the tipping loads and on tires do not exceed 75% of the tipping loads.

On Tires – Stationary – Boom Centered Over Front Between Tire Tracks
(All Capacities Are Listed In Pounds)

Radius (ft)	Boom Length (ft)					Radius (ft)
	33	40	50	60	70	
10	46,800	46,400				10
12	41,200	41,000	35,000			12
15	34,900	35,000	35,000			15
20	27,400	27,900	28,300	28,500		20
25	19,900	20,600	21,100	21,300	21,500	25
30		14,700	15,300	15,500	15,700	30
35			11,500	11,900	12,000	35
40			8,900	9,200	9,400	40
45				7,200	7,500	45
50				5,700	5,900	50
55					4,700	55
60					3,800	60

On Tires – Pick & Carry (Creep) – Boom Centered Over Front
(All Capacities Are Listed In Pounds)

Radius (ft)	Boom Length (ft)					Radius (ft)
	33	40	50	60	70	
10	44,500	44,200				10
12	38,700	38,500	35,000			12
15	32,100	32,500	32,800			15
20	24,400	24,800	25,200	25,400		20
25	19,000	19,500	20,000	20,200	20,400	25
30		14,700	15,300	15,500	15,700	30
35			11,500	11,900	12,000	35
40			8,900	9,200	9,400	40
45				7,200	7,500	45
50				5,700	5,900	50
55					4,700	55
60					3,800	60

On Tires – Stationary – 360° Rotation
(All Capacities Are Listed In Pounds)

Radius (ft)	Boom Length (ft)					Radius (ft)
	33	40	50	60	70	
10	36,500	36,100				10
12	30,500	31,000	31,300			12
15	21,500	22,000	22,400			15
20	12,800	13,400	13,900	14,100		20
25	8,200	8,800	9,300	9,600	9,700	25
30		5,900	6,400	6,700	6,900	30
35			4,400	4,700	4,900	35
40			2,900	3,300	3,400	40
45				2,200	2,400	45

This information is not for crane operation. Operator must refer to the in-cab information for crane operation. Rated lifting capacities shown on fully extended outriggers do not exceed 85% of the tipping loads and on tires do not exceed 75% of the tipping loads.

Fly Attachment Lift Capacity Charts – Optional

Fully Extended Outriggers – 360° Rotation (All Capacities Are Listed In Pounds)								
105 ft Main Boom Length 2° Fly Offset			105 ft Main Boom Length 20° Fly Offset			105 ft Main Boom Length 40° Fly Offset		
Radius (ft)	Fly Length (ft)		Radius (ft)	Fly Length (ft)		Radius (ft)	Fly Length (ft)	
	28.5	51		28.5	51		28.5	51
35	9,000		40	7,900		50	5,600	
40	9,000	5,800	45	7,500		55	5,500	
45	8,700	5,700	50	7,100		60	5,300	
50	7,900	5,400	55	6,600	3,700	65	5,200	
55	7,200	5,100	60	6,100	3,500	70	4,900	2,500
60	6,600	4,800	65	5,600	3,300	75	4,600	2,400
65	6,100	4,500	70	5,200	3,200	80	4,400	2,300
70	5,600	4,100	75	4,900	3,000	85	4,100	2,300
75	5,100	3,800	80	4,600	2,900	90	3,900	2,200
80	4,600	3,500	85	4,300	2,800	95	3,500	2,200
85	4,100	3,300	90	3,800	2,700	100	3,100	2,100
90	3,600	3,000	95	3,400	2,600	105	2,700	2,100
95	3,300	2,700	100	3,000	2,400	110		2,000
100	2,900	2,400	105	2,700	2,200	115		1,800
105	2,600	2,200	110	2,400	2,000	120		1,700
110	2,300	1,900	115	2,100	1,800	125		1,400
115	2,000	1,600	120	1,800	1,600	130		800
120	1,700	1,400	125		1,300			
125		1,200	130		1,100			
130		1,000	135		1,000			

This information is not for crane operation. Operator must refer to the in-cab information for crane operation. Rated lifting capacities shown on fully extended outriggers do not exceed 85% of the tipping loads and on tires do not exceed 75% of the tipping loads.

Main Boom Lift Capacity Charts – Optional (Metric)

Fully Extended Outriggers – 360° Rotation (All Capacities Are Listed In Kilograms)										
Radius (m)	Boom Length (m)									Radius (m)
	10.06	12.2	15.2	17.37/18.3	21.3	24.4	27.4	30.5	32.0	
3.0	40 000	32 650	31 950	19 850**						3.0
3.5	34 500	32 650	30 450	19 850**						3.5
4.0	31 500	31 400	28 250	19 850**						4.0
4.5	28 950	28 850	26 300	19 350**	15 850					4.5
5.0	26 750	26 650	24 600	17 950**	15 850					5.0
6.0	21 850	21 750	21 600	15 850	15 850	14 000				6.0
7.0	18 200	18 100	17 950	15 850	15 850	12 650	11 250			7.0
8.0	15 400	15 700	15 850	15 850	15 850	11 500	10 250	9 300	7 900	8.0
9.0		13 500	13 700	13 800	13 900	10 500	9 400	8 550	7 900	9.0
10.0		11 000	11 250	11 350	11 450	9 650	8 650	7 850	7 100	10.0
12.0			8 000	8 150	8 200	8 250	7 350	6 650	6 400	12.0
14.0				6 150	6 200	6 250	6 250	5 800	5 400	14.0
16.0				4 750	4 850	4 900	4 950	4 950	4 550	16.0
18.0					3 850	3 900	3 950	3 950	3 900	18.0
20.0						3 150	3 200	3 200	3 200	20.0
22.0							2 550	2 600	2 600	22.0
24.0								2 100	2 150	24.0
26.0									1 750	26.0
28.0									1 400	28.0
30.0										30.0

* Special Conditions Or Wire Rope Required
** 17.37 A – max Mode

This information is not for crane operation. Operator must refer to the in-cab information for crane operation. Rated lifting capacities shown on fully extended outriggers do not exceed 75% of the tipping loads and on tires do not exceed 65% of the tipping loads.

On Tires – Stationary – Boom Centered Over Front Between Tire Tracks (All Capacities Are Listed In Kilograms)						
Radius (m)	Boom Length (m)					Radius (m)
	10.06	12.2	15.2	18.3	21.3	
3	21 450	21 300				3
3.5	19 300	19 150	15 850			3.5
4	17 500	17 450	15 850			4
4.5	16 050	15 950	15 850			4.5
5	14 750	14 950	15 100			5
6	12 250	12 450	12 600	12 700		6
7	9 200	9 450	9 600	9 700	9 750	7
8	7 150	7 400	7 600	7 700	7 750	8
9		5 950	6 200	6 250	6 300	9
10		4 900	5 100	5 200	5 300	10
12			3 600	3 700	3 800	12
14				2 700	2 800	14
16				2 000	2 100	16
18					1 550	18

On Tires – Pick & Carry (Creep) – Boom Centered Over Front (All Capacities Are Listed In Kilograms)						
Radius (m)	Boom Length (m)					Radius (m)
	10.06	12.2	15.2	18.3	21.3	
3	20 400	20 250				3
3.5	18 150	18 050	15 850			3.5
4	16 350	16 250	15 850			4
4.5	14 750	14 950	15 100			4.5
5	13 400	13 600	13 750			5
6	11 250	11 450	11 600	11 700		6
7	9 200	9 450	9 600	9 700	9 750	7
8	7 150	7 400	7 600	7 700	7 750	8
9		5 950	6 200	6 250	6 300	9
10		4 900	5 100	5 200	5 300	10
12			3 600	3 700	3 800	12
14				2 700	2 800	14
16				2 000	2 100	16
18					1 550	18

This information is not for crane operation. Operator must refer to the in-cab information for crane operation. Rated lifting capacities shown on fully extended outriggers do not exceed 75% of the tipping loads and on tires do not exceed 65% of the tipping loads.

On Tires – Stationary – 360° Rotation (All Capacities Are Listed In Kilograms)						
Radius (m)	Boom Length (m)					Radius (m)
	10.06	12.2	15.2	18.3	21.3	
3	16 800	16 650				3
3.5	13 350	13 500	13 650			3.5
4	10 600	10 800	10 950			4
4.5	8 650	8 900	9 000			4.5
5	7 200	7 450	7 600			5
6	5 200	5 400	5 600	5 700		6
7	3 850	4 050	4 250	4 350	4 400	7
8	2 850	3 100	3 300	3 400	3 500	8
9		2 400	2 600	2 700	2 800	9
10		1 800	2 050	2 150	2 200	10
12			1 200	1 350	1 400	12
14				750	850	14

Fly Attachment Lift Capacity Charts – Optional (Metric)

Fully Extended Outriggers – 360° Rotation (All Capacities Are Listed In Kilograms)								
33.53m Main Boom Length 2° Fly Offset			33.53m Main Boom Length 20° Fly Offset			33.53m Main Boom Length 40° Fly Offset		
Radius (m)	Fly Length (m)		Radius (m)	Fly Length (m)		Radius (m)	Fly Length (m)	
	8.69	15.54		8.69	15.54		8.69	15.54
12	4 050		14	3 350		16	2 500	
14	3 900	2 550	16	3 100		18	2 450	
16	3 400	2 350	18	2 800	1 600	20	2 350	
18	3 050	2 200	20	2 550	1 500	22	2 150	1 100
20	2 750	2 000	22	2 300	1 400	24	2 000	1 050
22	2 450	1 800	24	2 100	1 350	26	1 850	1 050
24	2 150	1 650	26	1 900	1 250	28	1 700	1 000
26	1 850	1 500	28	1 650	1 200	30	1 450	1 000
28	1 600	1 300	30	1 400	1 150	32	1 200	950
30	1 350	1 150	32	1 200	1 000	34		900
32	1 100	1 000	34	950	900	36		800
34	900	800	36	750	750	38		650
36	700	700	38		600	40		300
38		550	40		500			

This information is not for crane operation. Operator must refer to the in-cab information for crane operation. Rated lifting capacities shown on fully extended outriggers do not exceed 75% of the tipping loads and on tires do not exceed 65% of the tipping loads.

Link-Belt Construction Equipment Company Lexington, Kentucky www.linkbelt.com

®Link-Belt is a registered trademark. Copyright 2004. We are constantly improving our products and therefore reserve the right to change designs and specifications.