



TECHNICAL DATA

HIGH-MU AIR-COOLED POWER TRIODE 3CX1500D7

The Eimac 3CX1500D7 is a compact power triode with an anode dissipation rating of 1500 watts. This tube features a filament designed to operate at 5 volts, a value that is common to other power grid tubes and allows a single 3CX1500D7 to replace two 3-500Z in many applications. The high-Mu grid employed in this tube permits operation as a linear amplifier in class AB with zero or minimal bias voltage. The 3CX1500D7 may also be used in class B or C with additional bias voltage where it provides good efficiency, making it ideal as an rf amplifier for industrial and scientific applications.

GENERAL CHARACTERISTICS¹

ELECTRICAL

Filament: Thoriated Tungsten	
Voltage.....	5.0 ± 0.25 V
Current @ 6.3 volts.....	30 A
Direct Interelectrode Capacitances (grounded grid) ²	
Cin.....	18.6 pF
Cout.....	7.2 pF
Cpk.....	0.4 pF
Amplification Factor, Average.....	200
Frequency of Maximum Rating (CW).....	100 MHz

MECHANICAL

Overall Dimensions:	
Length	5.6 in; 143 mm
Diameter	3.42 in; 86.9 mm
Weight (approx.)	2.4 lb; 1.1 kg
Operating Position.....	Vertical, base up or down
Maximum Operating Temperatures:	
Ceramic/Metal Seals & Envelope.....	250°C
Anode Core	250°C
Cooling	Forced Air
Base.....	Special, Five Pin
Recommended Socket	EIMAC SK-410

¹ Characteristics and operating values are based upon performance tests. These figures may change without notice as the result of additional data or product refinement. CPI Eimac Division should be consulted before using this information for final equipment design.

² Capacitance values are for a cold tube as measured in a special shielded fixture in accordance with Electronic Industries Association Standard RS-191.



3CX1500D7

RADIO FREQUENCY LINEAR AMPLIFIER Class AB2, Cathode-Driven

ABSOLUTE MAXIMUM RATINGS:

Anode Voltage.....	6.0	Kilovolts dc
Anode Current.....	0.8	Ampere dc
Anode Dissipation.....	1.5	Kilowatts
Grid Voltage.....	-500	Volts dc
Grid Dissipation	50	Watts

TYPICAL OPERATION*, under 30 MHz:

Anode Voltage.....	3.0	4.5	kVdc
Cathode Bias Voltage.....	0	12	Vdc
Zero-Signal Anode Current .	168	98	mAdc
Anode Current (max signal)	0.72	0.64	Adc
Grid Current* ¹	247	180	mAdc
Driving Power* ¹	80	70	W
Anode Dissipation* ¹	660	930	W
Anode Output Power* ¹	1.5	1.95	kW
Input Impedance.....	73	72	Ohms
Resonant Anode Load Z* ..	2650	2900	Ohms
Intermodulation Distortion			
Products ² , 3 rd order ...	-29	-34	dB
5 th order	-43	-37	dB

* Measured data

1. Approximate Values

2. Referenced against one tone of a two-equal tone signal

RADIO FREQUENCY POWER AMPLIFIER Class B, Cathode-Driven

ABSOLUTE MAXIMUM RATINGS:

Anode Voltage.....	6.0	Kilovolts dc
Anode Current.....	0.8	Ampere dc
Anode Dissipation	1.5	Kilowatts
Grid Voltage.....	-500	Volts dc
Grid Dissipation	50	Watts

TYPICAL OPERATION, under 30 MHz:

Anode Voltage	5.0	kVdc
Anode Current.....	0.71	Adc
Cathode Bias Voltage.....	25	Vdc
Grid Current * ¹	0.20	Adc
Driving Power* ¹	95	W
Anode Dissipation	1220	W
Anode Output Power.....	2400	W
Input Impedance.....	.85	Ohms
Resonant Anode Load Impedance..	3760	Ohms

1. Approximate Values

NOTE: TYPICAL OPERATION data are obtained from direct measurement or by calculation from published characteristic curves. Adjustment of the rf grid voltage to obtain the specified anode current at the specified bias and anode voltages is assumed. If this procedure is followed, there will be little variation in output power when the tube is changed.

RANGE VALUES FOR EQUIPMENT DESIGN

	Min.	Max.	
Filament Current @ 5.0 Volts.....	29.5	32	A
Interelectrode Capacitances ¹ (grounded grid)			
Cin	16.5	21	pF
Cout	5.8	8.9	pF
Cpk.....	---	0.6	pF
Zero-Signal Anode Current (Ec = 0, Eb = 4.0 kV)	0.305	0.375	A
Cut-off Bias (Eb = 3 kV, Ib = 1.0 mA)	---	- 24.0	V

¹ Capacitance values are for a cold tube as measured in a shielded fixture in accordance with Electronic Industries Association Standard RS-191.



APPLICATION

HANDLING – This product contains a thoriated-tungsten filament and should be protected from shock and vibration. It is recommended that the tube be removed from equipment that is being shipped, to prevent damage that may occur in transit.

The center “pin” in the base of this tube is hollow and is a part of the filament support structure and is at the same potential as the filament; no electrical contact to this pin is necessary or desirable. The vacuum “nip-off” or seal is located at the end of this center “pin”; the edge on it is very sharp and can cut. Do not touch or contact this seal as any mechanical damage to it may cause loss of vacuum integrity.

MOUNTING & SOCKETING – The tube must be operated with its primary axis vertical. The base of the tube may be up or down at the option of the equipment designer. The Eimac SK-410 socket is ideal for use with this tube; other sockets may restrict airflow or increase pressure-drop and are therefore not recommended. Sockets other than the Eimac SK-410 may also apply excessive lateral force to the connecting pins on the base, and this can result in mechanical failure of the metal/ceramic seals. An air chimney is necessary to assure that air flows through the fins in the anode cooler. A cylindrically-shaped Teflon™ or Pyrex chimney around the outside of the cooler is recommended for this purpose. Connection to the anode should be made by use of a band around the anode cooler.

STORAGE – If a tube is to be stored as a spare it should be kept in its original shipping carton with the original packing material to minimize the possibility of handling damage. Before storage a new tube should be operated in the equipment for 100 to 200 hours to establish that it has not been damaged and operates properly. If the tube is still in storage 6 months later it should be operated in the equipment for 100 to 200 hours to make sure there has been no degradation. If operation is satisfactory the tube can again be stored with great assurance of being a known-good spare.

COOLING - The maximum temperature rating for the anode core and the ceramic/metal seals of this tube is 250°C and sufficient forced-air cooling must be provided to assure operation at safe tube temperatures. Tube life is usually prolonged if cooling in excess of the absolute minimum requirements is provided.

The table below shows minimum airflow requirements necessary to keep the anode temperature below 225°C with an inlet air temperature of 25°C at sea level. Air-flow is specified to be in the base-to-anode direction. This data applies to operation below 30 MHz; if the tube is used above this frequency additional cooling may be required because of increased rf losses that occur at VHF.

Airflow Direction	Anode Dissipation Watts	Airflow CFM	Approximate Pressure Drop in H ₂ O
Base to Anode	500	15	0.09
“	1000	34	0.22
“	1500	65	0.45

At higher altitudes increased airflow is required; in this case both the airflow and pressure drop values shown must be increased by the following factors: 5000 feet x 1.24; 10,000 feet x 1.46. Additional cooling of the tube base may be required especially if the anode cooling air is not directed past the base first. The preferred configuration is airflow supplied in the base-to-anode direction; cooling air may be supplied in the alternate direction, but the flow rate must be substantially higher to provide proper cooling.

The designer is cautioned that the cooling recommendations shown are absolute values for inlet air and temperature rise conditions shown with no safety factor; it is considered good engineering practice to allow additional air flow for conservatism and to make allowance for variables such as dirty air filters, dirty anode cooling fins, and pressure losses in air ducting; other factors for additional airflow are the increased anode temperature that occurs during adverse load conditions and reduced anode efficiency that may occur during amplifier tuning and loading.



Cooling air should be filtered to remove particles of foreign matter that may become embedded in the anode cooling fins and impair cooling efficiency.

Temperature-sensitive paints are available which will allow a check of temperatures before any design is finalized. EIMAC Application Bulletin AB-20, TEMPERATURE MEASUREMENTS WITH EIMAC POWER TUBES, covers this subject in detail and is available on request.

ABSOLUTE MAXIMUM RATINGS - Values shown for each type of service are based on the "absolute system" and are not to be exceeded under any service conditions. These ratings are limiting values outside which serviceability of the tube may be impaired. In order not to exceed absolute ratings the equipment designer has the responsibility of determining an average design value for each rating below the absolute value of that rating by a safety factor so that the absolute values will never be exceeded under any usual conditions of supply-voltage variation, load variation, or manufacturing variation in the equipment itself. It does not necessarily follow that combinations of absolute maximum ratings can be attained simultaneously.

FILAMENT OPERATION - This tube is designed for commercial service, with no more than one normal off/on filament cycle per day. If additional cycling is anticipated it is recommended the user contact Application Engineering at CPI/Eimac for additional information.

With a new tube, or one that has been in storage for some period of time, operation with filament voltage only, at the nominal value of 5.0 volts, applied for a period of 30 to 60 minutes is recommended before full operation begins. This allows the active getter material mounted within the filament structure to absorb any residual gas molecules which have accumulated during storage. Once normal operation has been established a minimum filament warm-up time of five seconds is normally sufficient.

At rated (nominal) filament voltage the peak emission capability of the tube is many times that needed for communications service. A reduction in filament voltage will lower the filament temperature, which will substantially increase life expectancy. The correct value of filament voltage

should be determined for the particular application. It is recommended the tube be operated at full nominal voltage for an initial stabilization period of 100 to 200 hours before any action is taken to operate at reduced voltage. The voltage should gradually be reduced until there is a slight degradation in performance (such as power output or distortion). The voltage should then be increased a few tenths of a volt above the value where performance degradation was noted for operation. The operating point should be rechecked after 24 hours. Filament voltage should be closely regulated when voltage is to be reduced below nominal in this manner, to avoid any adverse influence by normal line voltage variations. Filament voltage should be measured at the tube base or socket, using an accurate rms-responding meter.

Eimac Application Bulletin #18, EXTENDING TRANSMITTER TUBE LIFE, gives information on the effect of filament voltage on life expectancy.

When cold, the resistance of a thoriated tungsten filament is very low, therefore the initial starting (inrush) current when filament voltage is applied can be many times the normal (hot) current; this can be detrimental to the longevity of a filament structure. Filament inrush current should never exceed a value of twice the nominal rated current. The use of a special impedance-limited filament transformer or other "step-start" circuitry in the supply side (primary) of the filament transformer is recommended.

If a single 3CX1500D7 is replacing two 3-500Z, a filament choke capable of carrying 30 Amperes may be required, alternatively two 15 Amp rated chokes may be connected in parallel. Verification of the current rating of existing filament connecting leads is highly recommended if retrofitting another tube with the 3CX1500D7.

INPUT CIRCUIT – When operated as a cathode-driven amplifier, the use of a resonant circuit in the cathode is recommended. For best results with a linear amplifier, it is suggested the cathode match-ing network have a "Q" of 2 or more.

INTERMODULATION DISTORTION - Typical operating conditions and IMD values are derived from measurements made at 2 MHz and are referred to one tone of a two-tone test signal. Bias voltage and drive power values other than shown may affect distortion products, and IMD performance may vary with input circuit "Q".



ZERO-BIAS OPERATION – In linear amplifiers with an anode voltage up to and including 3000 Volts, the 3CX1500D7 may be used with no external bias voltage, although additional bias may be employed to decrease the resting (zero drive) anode current. Above 3000 Volts some cathode bias is necessary to reduce anode dissipation and increase operating efficiency. High power zener diodes or a series-connected string of forward-conducting rectifier diodes are generally suitable for obtaining bias voltage in most linear amplifier applications using this tube. In classes B and C a simple resistor in the dc cathode return can be used to obtain the necessary cathode bias; if driving power fails, plate dissipation is then kept to a low value because the tube will be operating at the normal static zero-bias conditions.

GRID OPERATION - The maximum allowable grid dissipation for the 3CX1500D7 is 50 Watts. This can be determined approximately by the product of the dc grid current and the peak positive grid voltage. This value should not be exceeded except during tuning for very short periods. A grid over-current protection circuit with interlock set to trip-off above approx. 0.3 ampere is highly recommended, the exact value should be determined empirically under actual operating conditions with a normal (non-reactive) load so that if a substantial mismatch occurs grid protection circuitry will be activated.

FAULT PROTECTION - In addition to normal cooling interlocks, grid and anode over-current interlocks, it is good practice to protect the tube from internal damage which could result from occasional arcing at high plate voltage. In all cases, some protective resistance, at least 10 Ohms, should be used in series with the tube's anode supply to absorb power supply stored energy in case an arc should occur. An electronic crowbar, which will discharge power supply capacitors in a few microseconds after the start of an arc, may be required. The test for each electrode supply is to short each electrode to ground, one at a time, through a vacuum relay switch and a 6-inch length of #30 AGW copper wire. The wire will remain intact if protection is adequate. Eimac Application Bulletin #17, **FAULT PROTECTION**, contains considerable detail and is available upon request.

INTERELECTRODE CAPACITANCE - The actual internal interelectrode capacitance of a tube is influenced by many variables in most applications, such as stray capacitance to the chassis, capacitance added by the socket used, stray capacitance between tube terminals, and wiring effects. To control the actual capacitance values within the tube, as the key component involved, the industry and the Military Services use a standard test procedure as described in Electronic Industries Association Standard RS-191. This requires the use of specially constructed test fixtures, which effectively shield all external tube leads from each other and eliminates any capacitance reading to "ground". The test is performed on a cold tube in a shielded fixture. Other factors being equal, controlling internal tube capacitance in this way normally assures good interchangeability of tubes over a period of time, even with tubes made by different manufacturers. Capacitance values shown in the manufacturer's technical data, or test specifications, normally are taken in accordance with Standard RS-191.

The equipment designer is therefore cautioned to make allowance for the actual capacitance values which will exist in any normal application. Measurements should be taken with mounting which represents approximate final layout if capacitance values are highly significant in the design.

HIGH VOLTAGE - The 3CX1500D7 operates at voltages which can be deadly, and the equipment must be designed properly and operating precautions must be followed. Equipment must be designed so that no one can come in contact with high voltages. All equipment must include safety enclosures for high-voltage circuits and terminals, with interlock switches to open the primary circuits of the power supplies and to discharge high-voltage capacitors whenever access doors are opened. Interlock switches must not be bypassed or "cheated" to allow operation with access doors open. Always remember that **HIGH VOLTAGE CAN KILL**.

RADIO-FREQUENCY RADIATION - Avoid exposure to strong rf fields even at relatively low frequency. Absorption of rf energy by human tissue is dependent on frequency. Under 300 MHz most of the energy will pass completely through



3CX1500D7

the body with little attenuation or heating effect. Public health agencies are concerned with the hazard, and the published OSHA (Occupational Safety and Health Administration) or other local recommendations to limit prolonged exposure of rf radiation should be followed.

HOT SURFACES - Air-cooled surfaces and other parts of tubes can reach temperatures of several hundred degrees C and cause serious burns if

touched for several minutes after all power is removed.

SPECIAL APPLICATIONS - If it is desired to operate this tube under conditions widely different from those given here, contact the Application Engineering Dept., CPI Eimac Division, San Carlos, Calif. 94070 U.S.A. for information and recommendations.

OPERATING HAZARDS

Proper use and safe operating practices with respect to power tubes are the responsibility of equipment manufacturers and users of such tubes. All persons who work with and are exposed to power tubes, or equipment that utilizes such tubes, must take precautions to protect themselves against possible serious bodily injury. **DO NOT BE CARELESS AROUND SUCH PRODUCTS.**

The operation of this tube may involve the following hazards, any one of which, in the absence of safe operating practices and precautions, could result in serious harm to personnel.

HIGH VOLTAGE – Normal operating voltages can be deadly. Remember that **HIGH VOLTAGE CAN KILL.**

LOW-VOLTAGE HIGH-CURRENT CIRCUITS - Personal jewelry, such as rings, should not be worn when working with filament contacts or connectors as a short circuit can produce very high current and melting, resulting in severe burns.

RF RADIATION – Exposure to strong rf fields should be avoided, even at relatively low frequencies. **CARDIAC PACEMAKERS MAY BE AFFECTED.**

HOT SURFACES – Surfaces of tubes can reach temperatures of several hundred °C and cause serious burns if touched for several minutes after all power is removed.

MATERIAL COMPLIANCE - This product and package conforms to the conditions and limitations specified in 49CFR 173.424 for radioactive material, excepted package-instruments or articles, UN2910. In addition, this product and package contains no beryllium oxide (BeO).

Please review the detailed Operating Hazards sheet enclosed with each tube, or request a copy from CPI, Eimac Division Application Engineering at 1-650-592-1221.



3CX1500D7

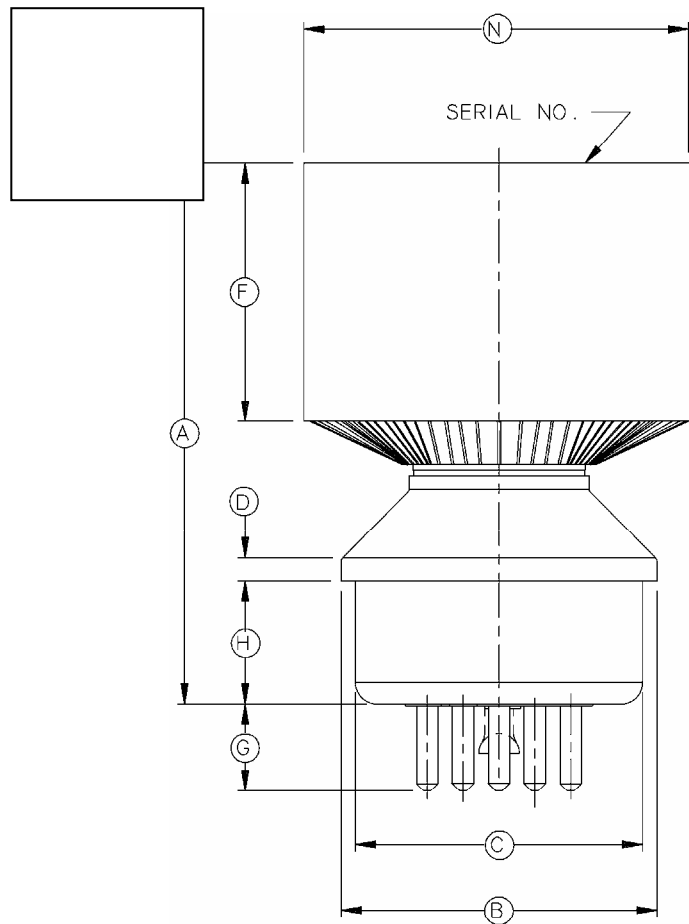

DIM.	INCHES			MILLIMETERS		
	MIN.	MAX.	REF.	MIN.	MAX.	REF.
A		4.750			120.65	
B			2.750			69.85
C			2.500			63.50
D			.212			5.38
F			2.250			57.15
G	.700	.800		17.78	20.32	
H			1.073			27.25
K			30°			
L	.185	.191		4.70	4.85	
M			1.250			31.75
N			3.420			86.87

NOTE:
1. REFERENCE DIMENSIONS ARE FOR INFORMATION ONLY AND ARE NOT REQUIRED FOR INSPECTION PURPOSES.

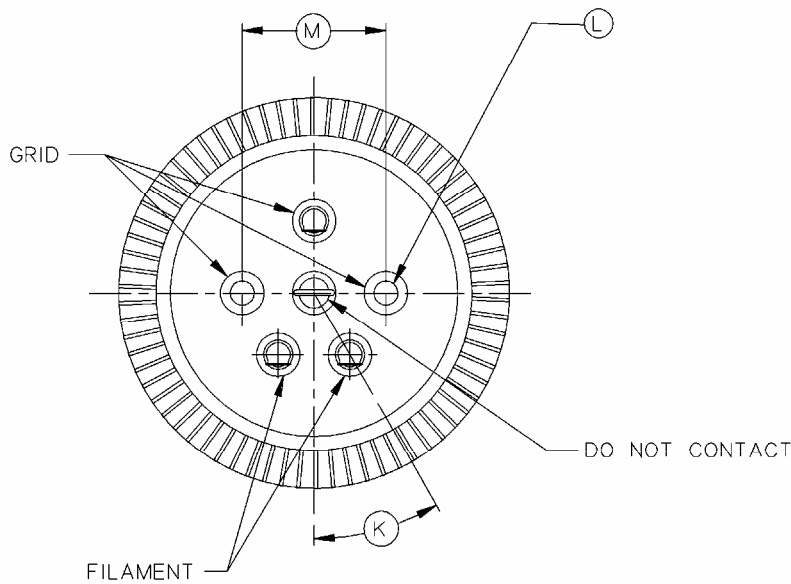

301 Industrial Road, San Carlos, CA 94070 • Tel: 650-592-1221 • Fax: 650-592-9988
04/03 Printed in USA.