

# Technical Guide

Fittings - Assembly - Fixings - Maintenance

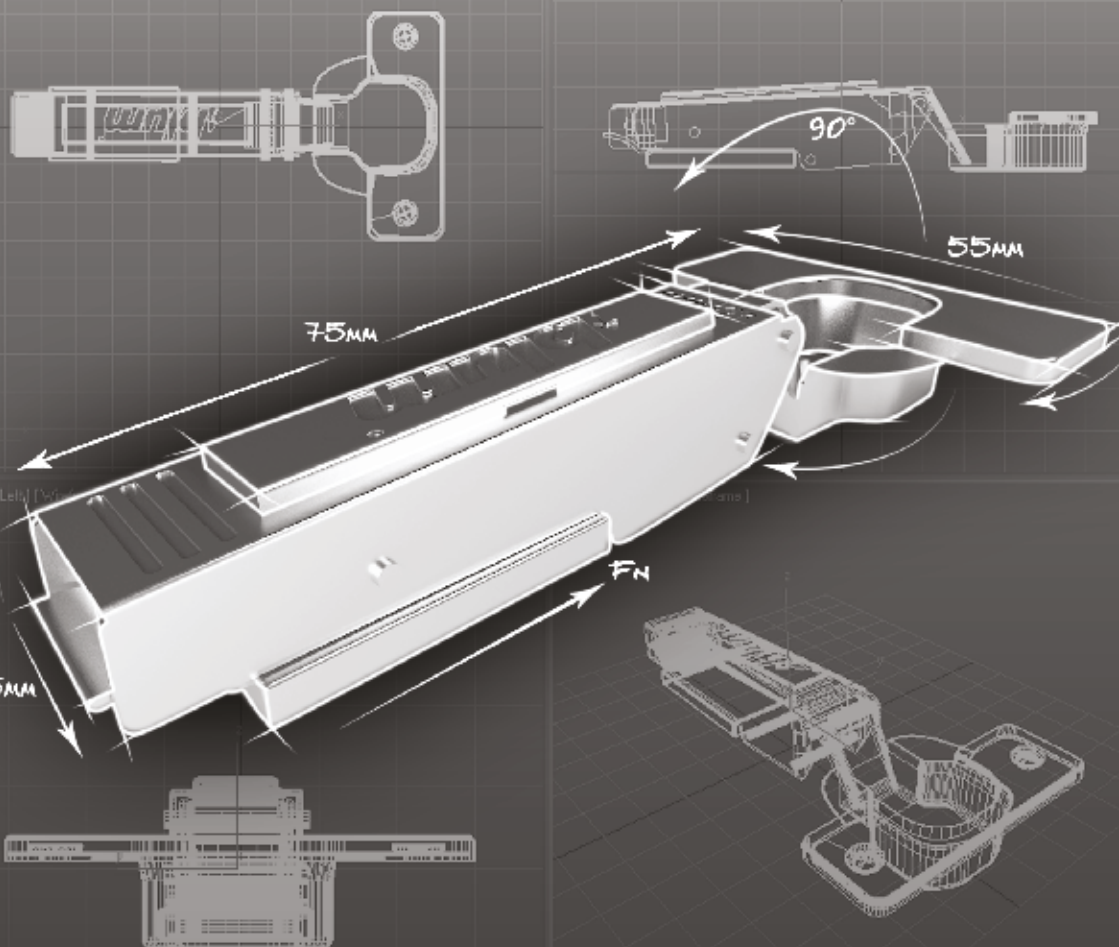

[Top] [Wireframe] [Front] [Wireframe]



# Kitchen Instruction Contents

Page 1  
Adjustable Leg & Plinth Fixing



Page 2  
Side Plinth Fixing

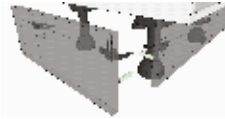

Page 3  
Drawer Box Fitting

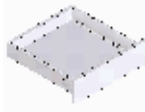

Page 4  
Drawer Front Fixing



Page 5  
Drawer Adjustment



Page 6  
Pan Drawer Front Fixing

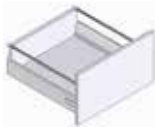

Page 7/8  
Hinge Adjustment



Page 9/10  
Hinge Jig Guidelines



Page 11  
Adjustable Wall Hanging  
Brackets



Page 12  
Wall Cabinet Fitting



Page 13  
Glass Shelf Support



Page 14  
Corner Cabinet Positioning



Page 15/16  
Corner Base Cabinet Assembly



Page 17  
Double Hinge Door Drilling



Page 18  
Corner Wall Door Width  
Reduction



Page 19/20/21  
Diagonal Corner Cabinet  
Assembly



Page 22  
Top Box Door Drilling



Page 23  
Cabinet Connection



Page 24  
General Info

Page 25  
Door Care and Maintenance



# Adjustable Legs and Plinth Fixing

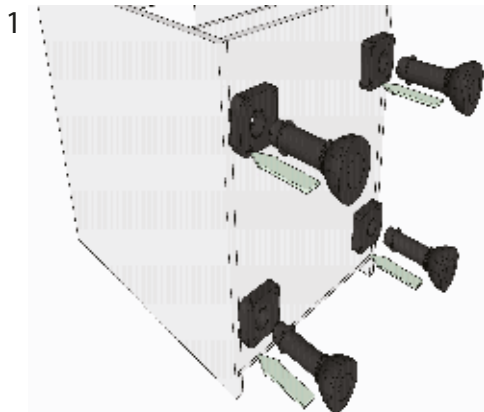

1 Lay unit on its back and slot the adjustable legs in.

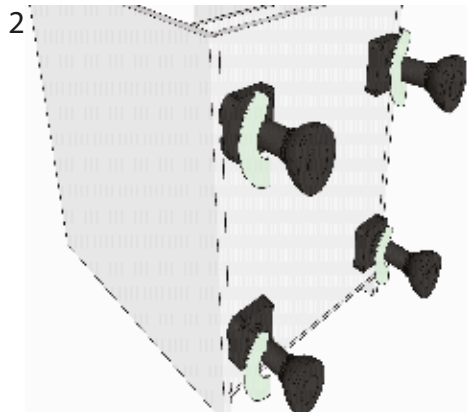

2 Rotate the legs into the locked position.

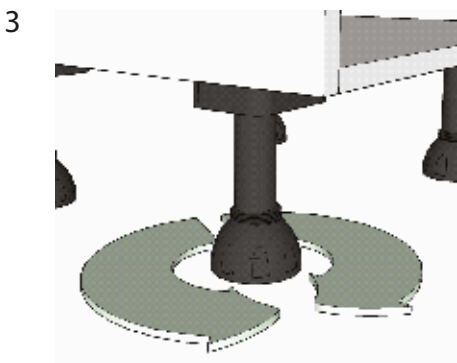

3 Stand the unit upright and turn the foot base section to adjust the level of the unit. Leg adjustment is -10mm down and +20mm up.

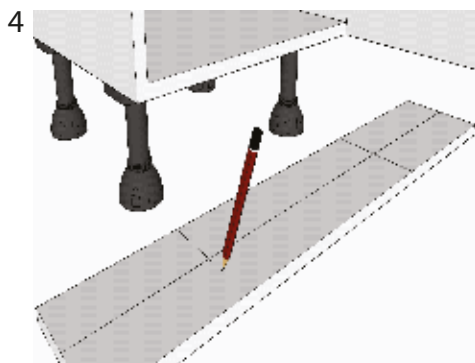

4 Lay Plinth in front of the cabinets to fit to and mark Centre of leg on plinth and the centre of the plinth.

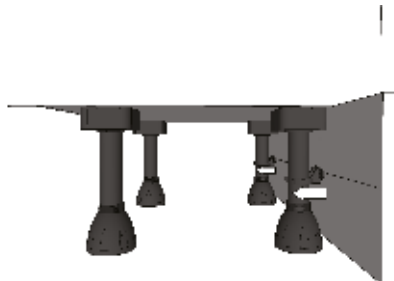
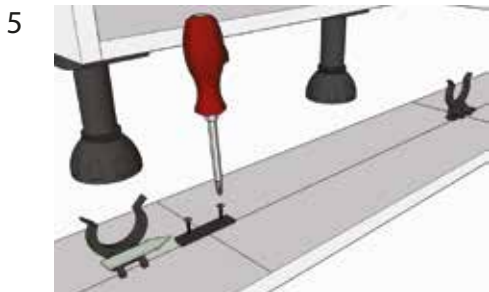

5 Screw the plinth clip back plate central to the markings made in the last step. Then slide the plinth Clips onto the back plates. Finally offer the plinth with the clips into place and slide the clips onto The back plates to line up with the legs before pushing the plinth into place allowing the clips to spring around the legs.

6

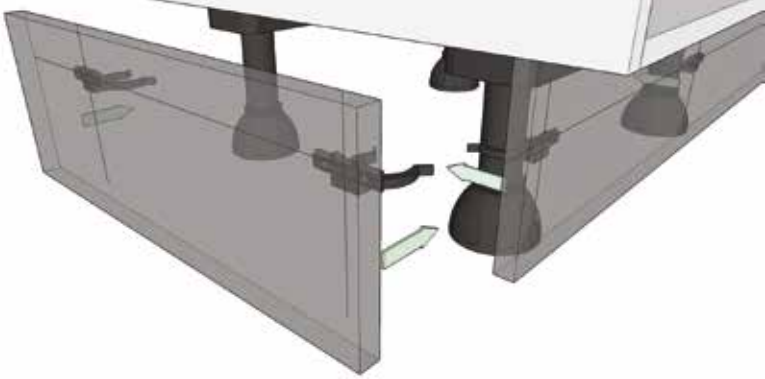

When fitting side return plinths, fit plinth clips to plinth in the previously mentioned way, making sure to fit the clips above the centre of the plinth. This will prevent the front clips from clashing

# Drawer Box Fitting

Attaching the drawer assembly onto the runners

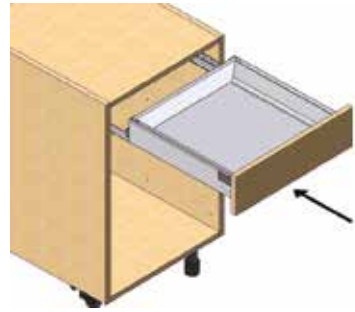
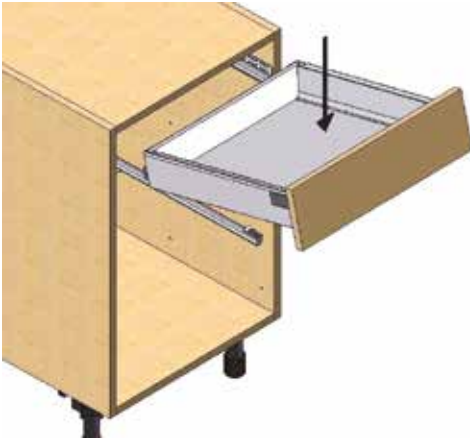

Extend the drawer runners out of the cabinet. Offer the drawer assembly onto the runners and gently lower into place. Push the drawer assembly into the cabinet. You will hear an audible 'click' when the drawer has connected correctly onto the runners

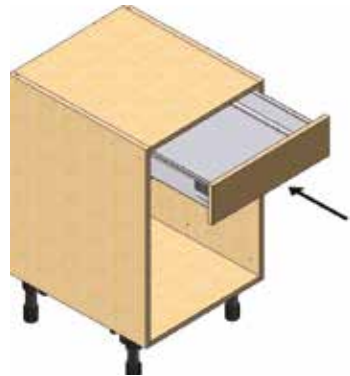

Removing the drawer assembly from the runners

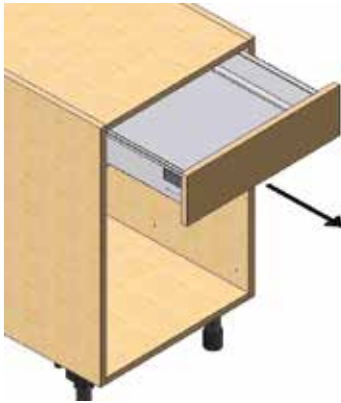

Fully extend the drawer assembly from the cabinet. Lift the drawer upwards, off the runners as shown

# Drawer Front Fixing

Please note that the drawer front clips are already located into the drawer sides for transportation reasons. Using a screw driver, turn the centre screw A to unlock the front brackets from the connection plates within the box

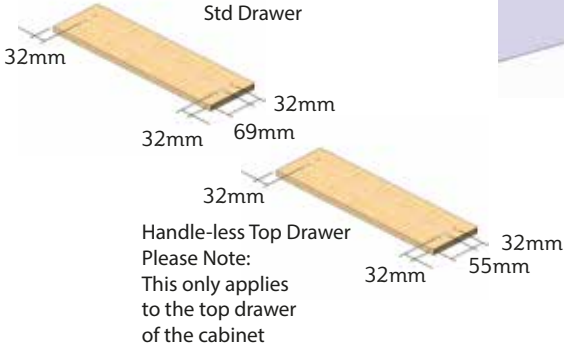

Drill 4 pilot holes for drawer front clips in Positions shown on the rear of drawer front

Screw fix drawer front clips to rear of drawer front

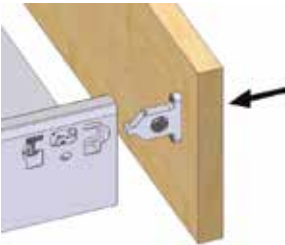

To connect the drawer front to the drawer box simply align the brackets on the drawer front with the drawer box and push onto box until it clicks into place

After adjustment clip the cover caps into place over the adjustment 'windows' on each side of the box

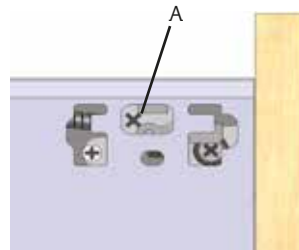
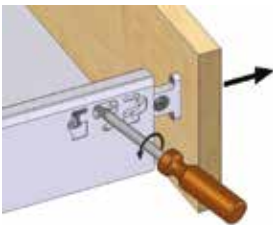

To remove the drawer front from the box. Use a screwdriver and turn the centre screw A to unlock the front brackets from the connection plates within the box

# Drawer Adjustment

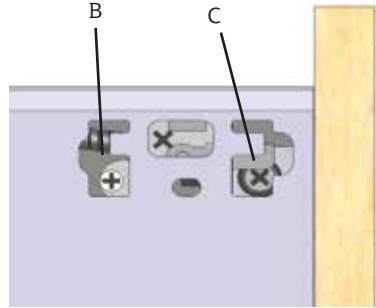
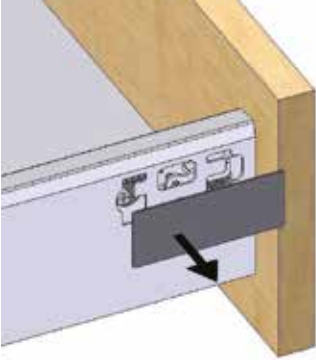

Adjustment screws B and C for drawer box adjustment

Remove cover caps from each side of the drawer box to expose the drawer adjustment screws. The cap simply clips into the drawer adjustment 'window'

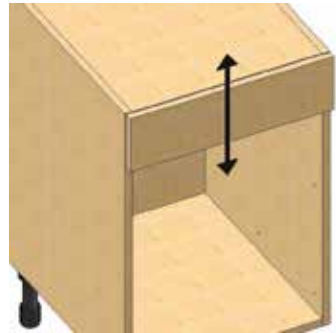
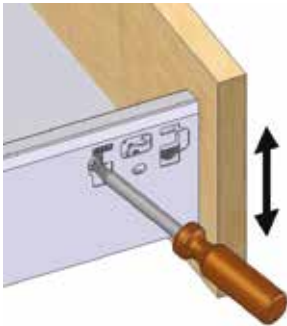

Vertical Adjustment - Turn rear adjustment screw B to give vertical adjustment to drawer box

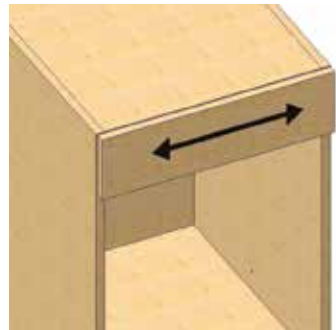
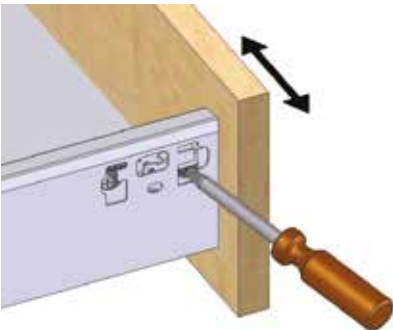

Horizontal Adjustment - Turn rear adjuster screw C to give horizontal adjustment to drawer box

# Pan Drawer Front Fixing

Pan drawers are similar to normal drawers but rails are fitted on either side of the drawer box back and the rear of the drawer front. Please Note: There is no different drilling position for the handle-less version of the pan drawer fixing.

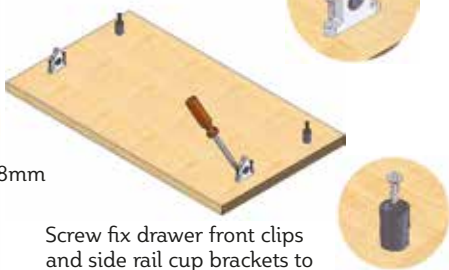
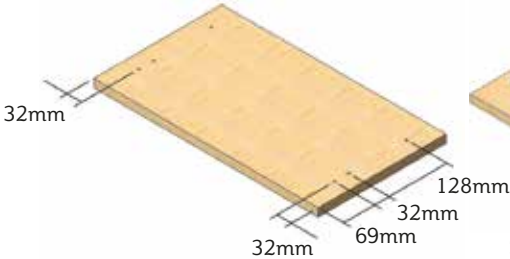
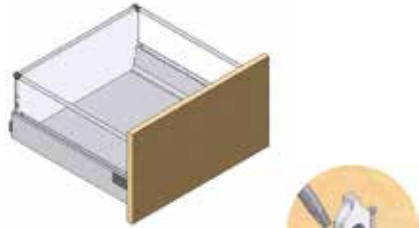

Drill 4 pilot holes for drawer front clips and 2 pilot holes for side rail cup brackets in the positions shown on rear of drawer front

Screw fix drawer front clips and side rail cup brackets to the rear of the drawer front

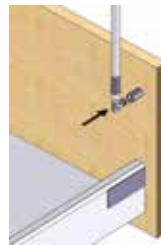

Attach pan drawer box to front as on a standard drawer

Push plastic bush on end of side rails into cup brackets on rear of drawer front

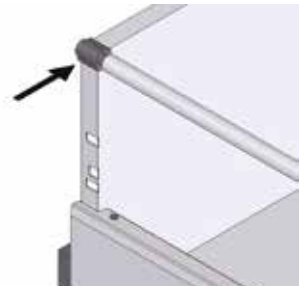
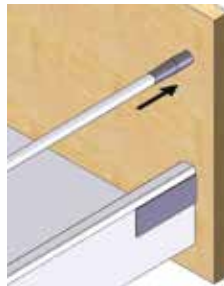
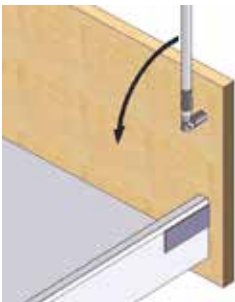

Lower side rail into position and push the rail sleeves forward to cover the front fixing bush

Push the rear rail fixing clips onto the corners of the drawer back panel and clip into place



# 107° Hinge and Hinge Plate Instructions

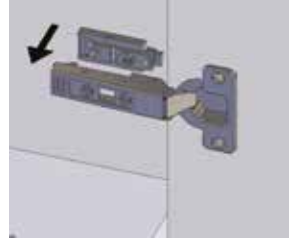
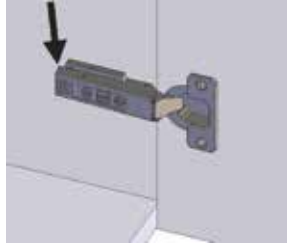
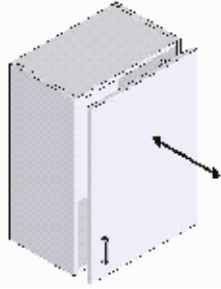

To release hinges from hinge plates, press the metal clip to the rear of the hinge plate and lift the hinge arm away from the plate

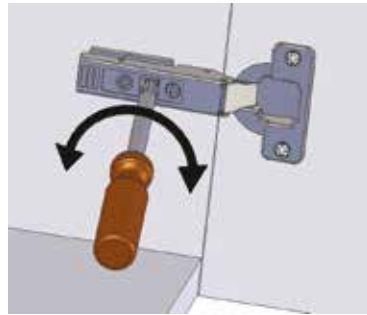
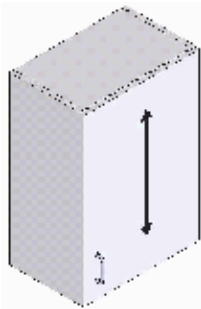

To adjust door up and down, turn the screw in the centre of the hinge (located on the plate)

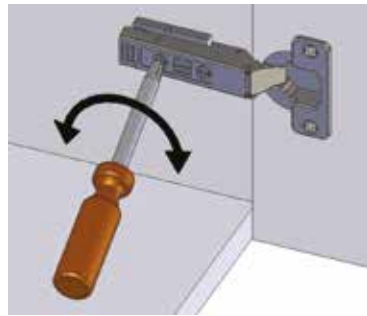
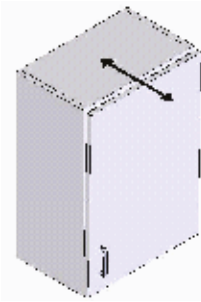

To adjust door in and out, turn the screw at the rear of the hinge

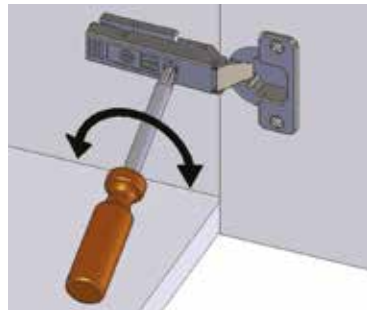
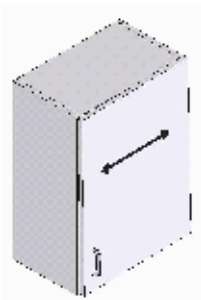

To adjust the door from side to side, turn the screw to the front of the hinge arm

# 170° Hinge & Hinge Plate Instructions

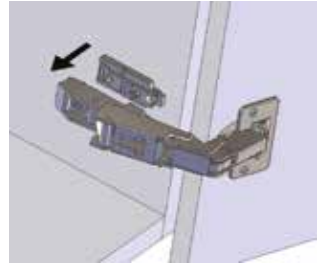
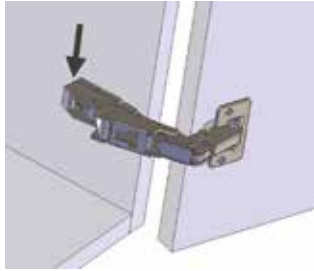
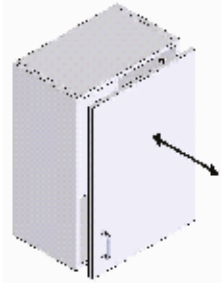

To release hinges from hinge plates, press the metal clip to the rear of the hinge plate and lift the hinge arm away from the plate

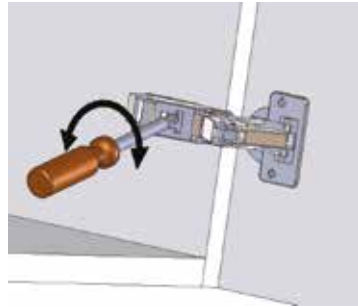
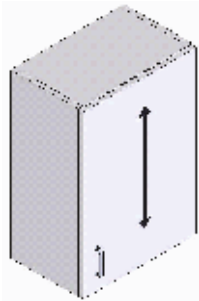

To adjust door up and down, turn the screw in the centre of the hinge (located on the plate)

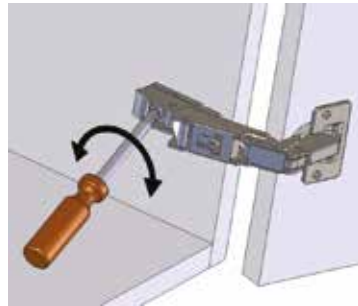
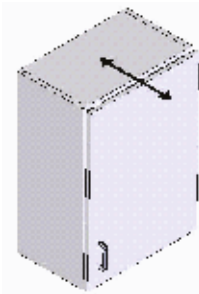

To adjust door in and out, turn the screw at the rear of the hinge

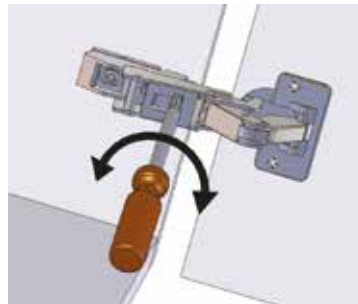
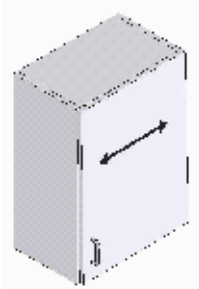

To adjust the door from side to side, turn the screw to the front of the hinge

# Hinge Jig Guidelines

## General

The hinge jig is a very useful tool for replacement doors and some appliance doors that are not factory drilled. They can be hired or purchased from us to aid drilling the doors correctly. Firstly you should familiarize yourself with the jig. Read the instructions fully and then attempt a practice run. This jig is suitable for most 35mm hinges. As well as the jig you will also need an electric hand drill, a set square and a pencil. You should carefully secure the doors to a work bench before using the jig. During the rental of this item Ultima Furniture take no liability.

## Instructions

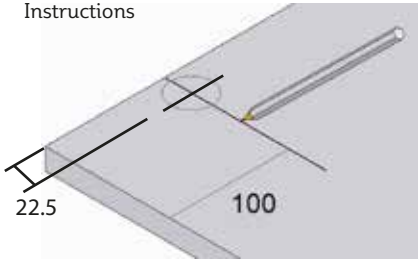

Usual centre line positions  
100mm from top and  
bottom edges

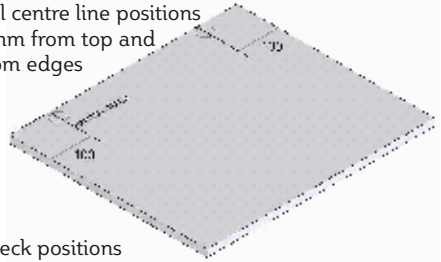

Check positions  
carefully before drilling.

Mark a line with a set square on the rear of the door which corresponds to the desired hinge hole centre.

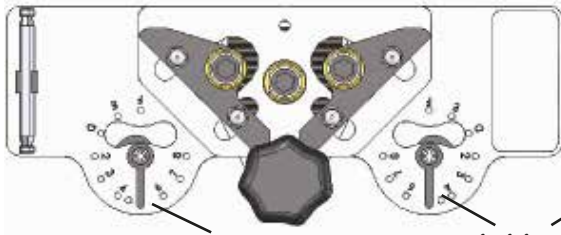

Position 5

Block levels set  
to position 5



Set the block levels on each side of the jig to level 5

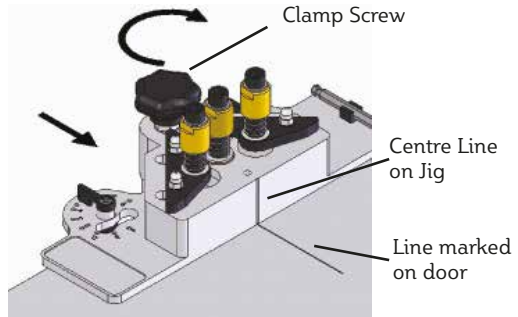
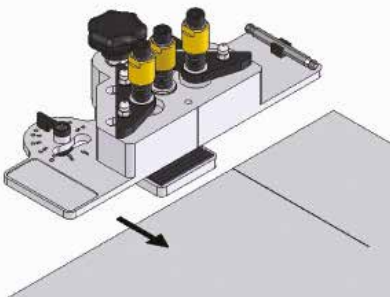

Position the jig on the door edge. The centre groove on the jig should align with the centre line marked on the door. Ensure the block buffers are tight against the door edge. Clamp the jig securely in position by turning the clamp screw as shown.

Check the block levels are set to 5 on each side of the jig

Remove the hexagonal shaft from its clamp on the jig. Insert the hexagonal shaft into an electric hand drill.

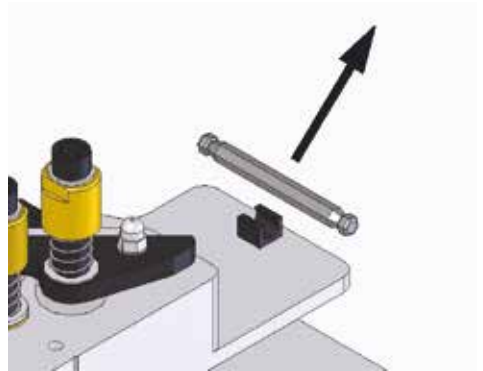

Lock the hexagonal shaft into the drill and then into the top of the centre shaft on the jig. Ensure the shaft is securely located before operating the drill.

Turn the drill on and push down

The spring below the gold hexagonal shaft should be fully compressed.

Then release the pressure. (Do not remove the shaft until the drill has stopped.)

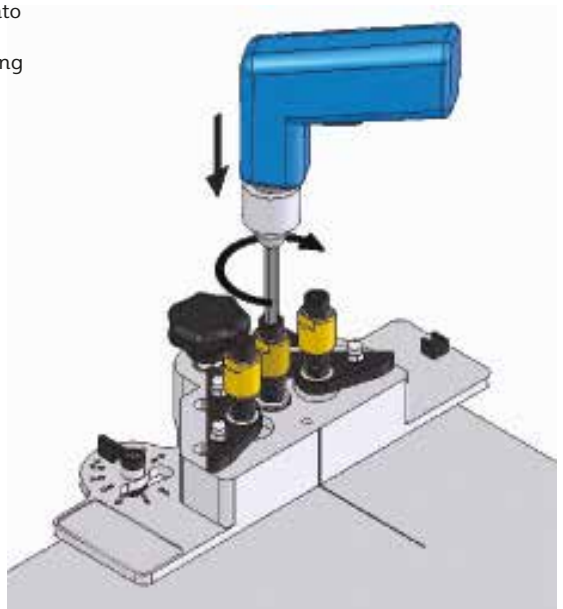

Repeat the above process for the other hinge holes.

(We would recommend that you practise on a scrap door prior to using the device on your own doors.)

Option: There are 2 brass locator holes on the jig, these are for making the screw hole positions for the hinge. (caution when using these, they may be slightly out of position due to the hinge type.)

# Adjustable Wall Hanging Brackets

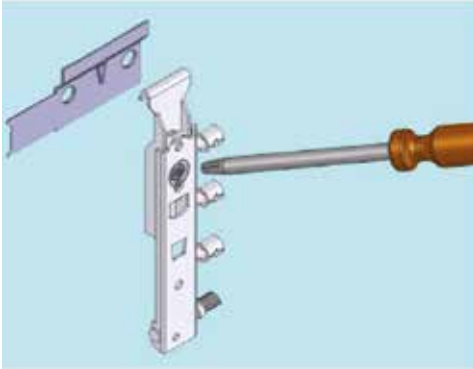

Wall units are fitted with adjustable rear hanging brackets

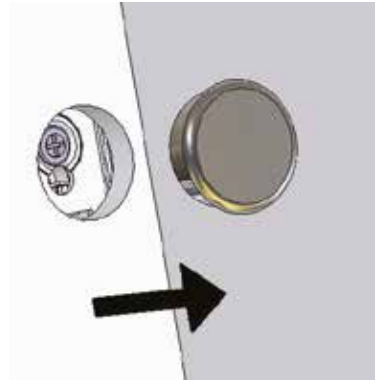

Remove cover caps on inside of cabinet.

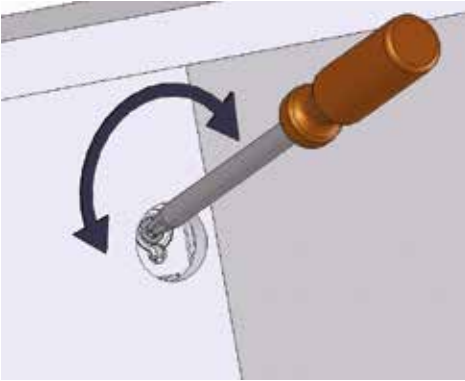

Turn the top adjustment screw to adjust the unit from front to back

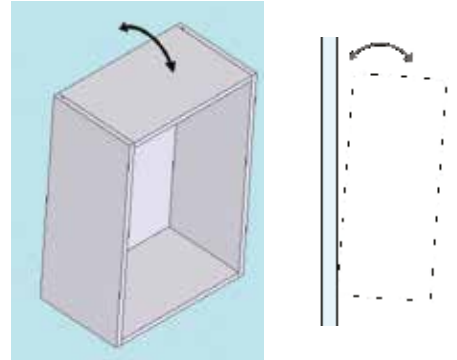

Allows unit to tilt forwards or backwards from the wall.

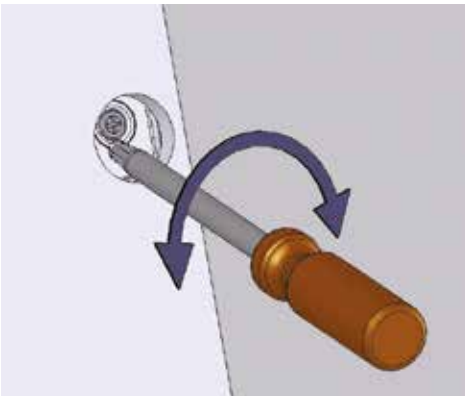

Insert screwdriver into hole below the top screw and turn to move unit up and down

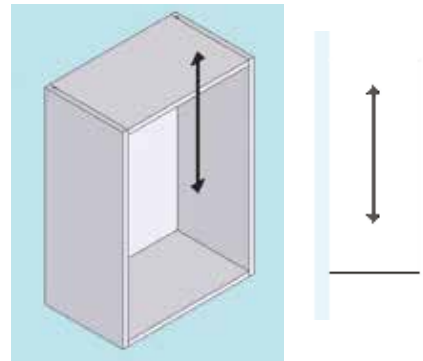

Adjusts unit for height. By adjusting at both sides the unit can be levelled.

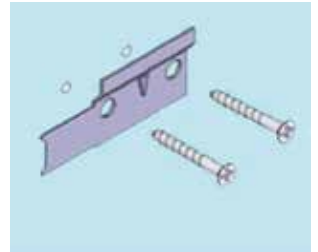
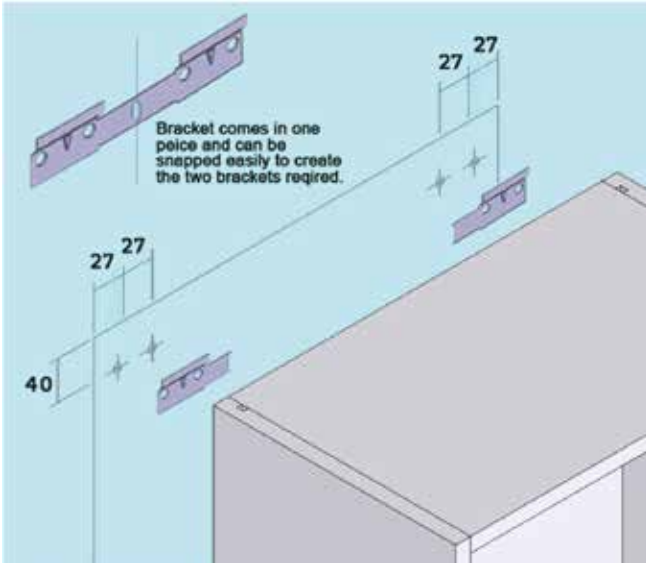

Wall units are hung on adjustable wall hanging brackets. The brackets are supplied with wall hanging plates which should be secured to the wall with suitable wall fixings. The hanging plate drilling positions are shown above

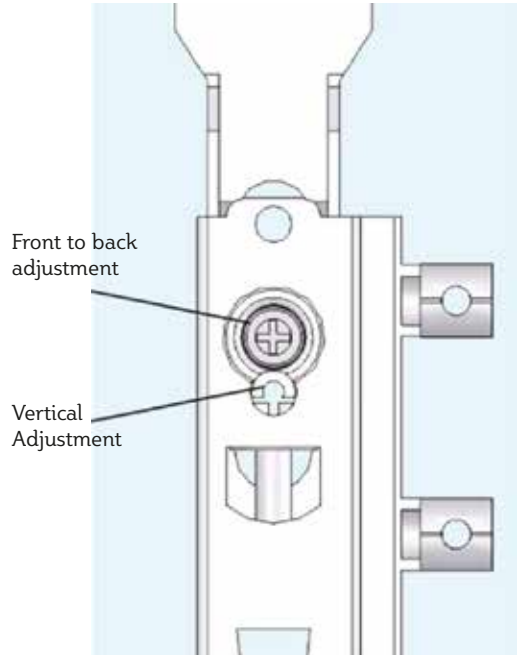
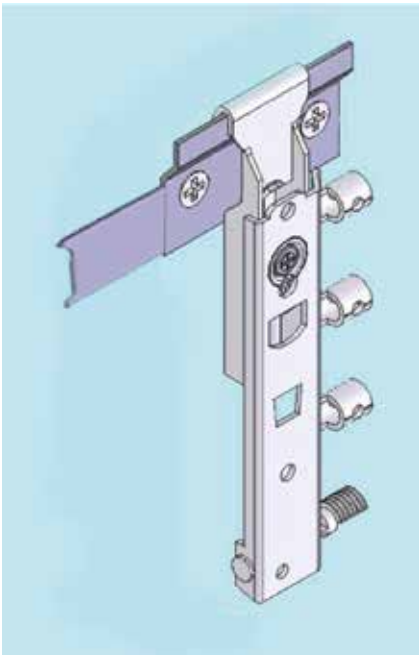

This type of shelf peg is used on shelves wider than 600mm

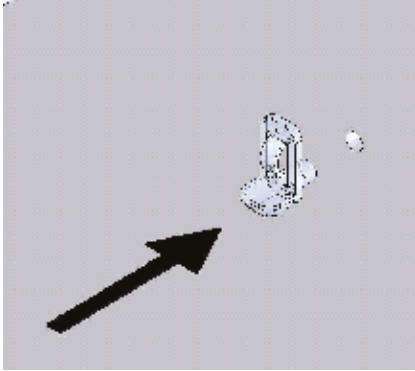

Insert shelf supports into holes in end panel.

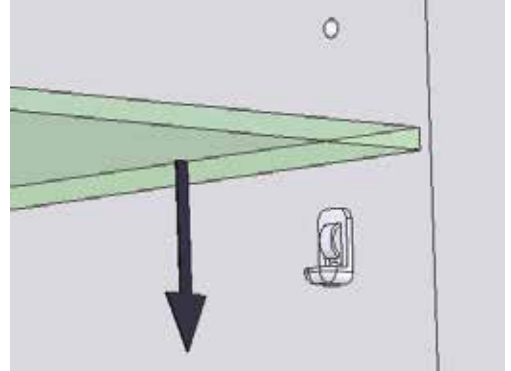

Drop shelf down into place

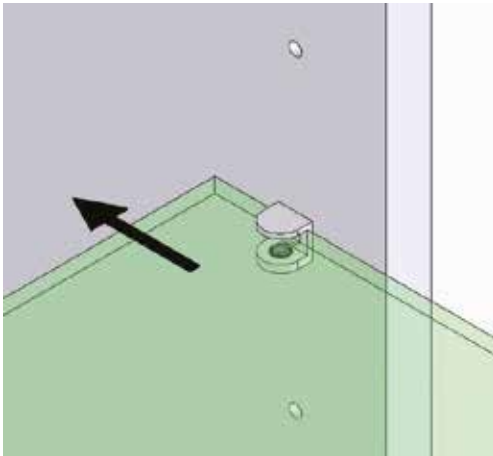

Insert glass shelf supports into holes in end panel and slide glass shelves into place.

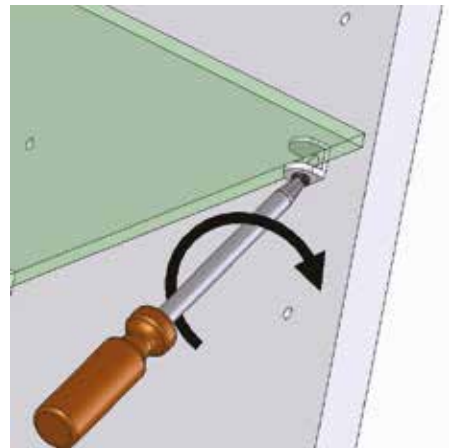

Tighten screw on underside of shelf support to hold shelf in place

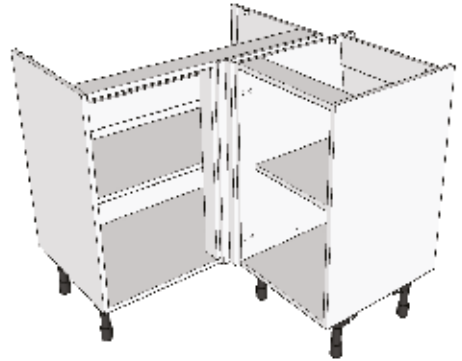
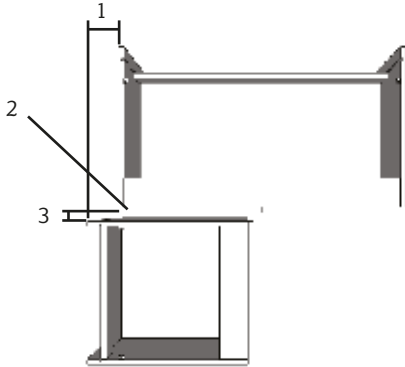

1. Position the corner blank base cabinet to a minimum of 100mm from the wall (130mm recommended). This dimension will vary depending on the handle clearance needed to avoid 'handle clash' between the two cabinets. If using 130mm recommendation, corner post will be 70mm square.
2. If using a corner fillet remove the blanking panel and fit the corner fillet as shown. Re-fit the blanking panel butting it up to the back edge of the fillet. Trim if required.
3. Fit the adjoining cabinet into position as shown allowing a minimum gap between the two cabinets. Again remember to allow for handle clashing.

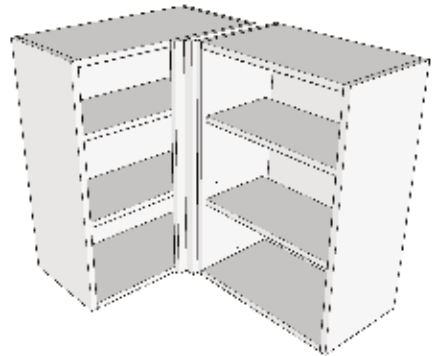
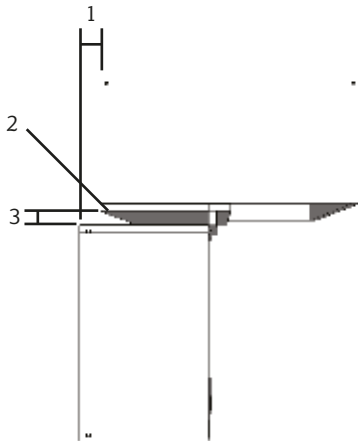

1. Position the corner blank wall cabinet to a minimum of 20mm from the wall (30mm recommended). This dimension will vary depending on the handle clearance needed to avoid 'handle clash' between the two cabinets. If using 30mm recommendation, corner post will be 30mm square.
2. If using a corner fillet remove the blanking panel and fit the corner fillet as shown. Re-fit the blanking panel butting it up to the back edge of the fillet. Trim if required.
3. Fit the adjoining cabinet into position as shown allowing a minimum gap between the two cabinets. Again remember to allow for handle clashing.

Please note that if your corner base solution has a minimum 40mm corner post you will not need to use a corner post in the wall situation (so that everything lines up), fit the adjacent cabinet up to the blank panel.



# Corner Base Unit Assembly

## Double Hinged Doors

Parts supplied:

- A - Left hand end panel
- B - Right hand end panel
- C - Top panel
- D - Base panel with legs attached
- E - Left hand back panel
- F - Diagonal rear back panel
- G - Right hand back panel
- H - Shelf panel
- J - Door double hinged
- K - Door single hinged

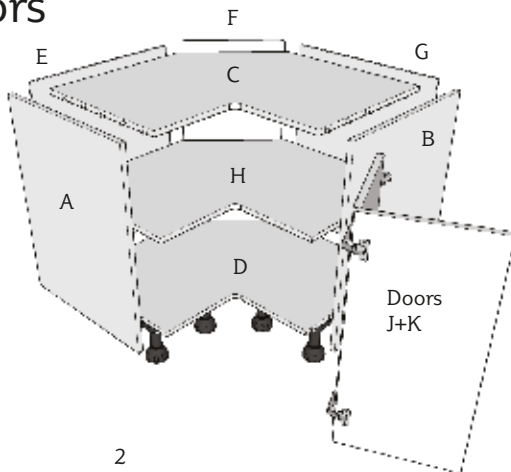

1

2

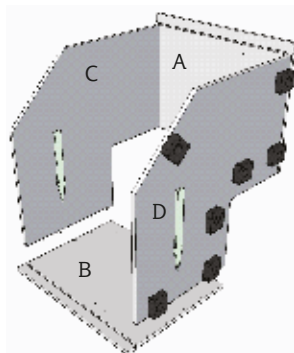
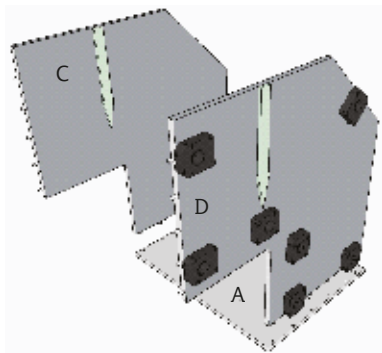

Lay left hand end panel A flat apply glue to dowel and insert top and base panels C & D, ensuring that dowels fully enter holes.

Apply glue to dowel holes in right hand end panel B and push into place, ensure that dowels fully enter holes.

3

4

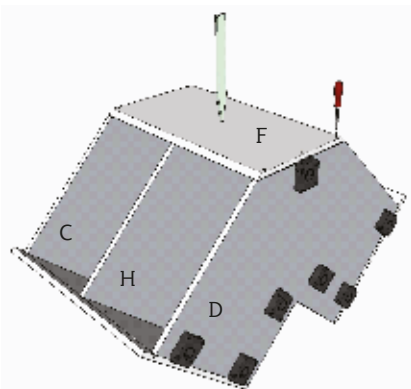
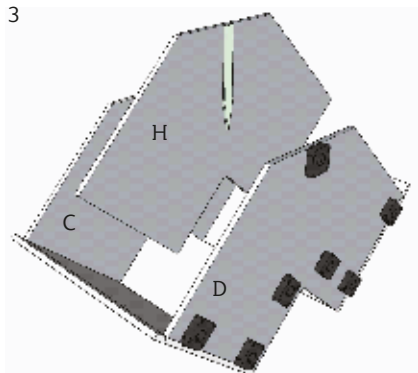

Lay unit onto its front edges. (ensuring that front edges are protected)  
Fit corner shelf panel H into place through back space.

Position rear angled back panel F and screw fix to back edges of top and base panels C & D. (ensure that all edges are aligned)

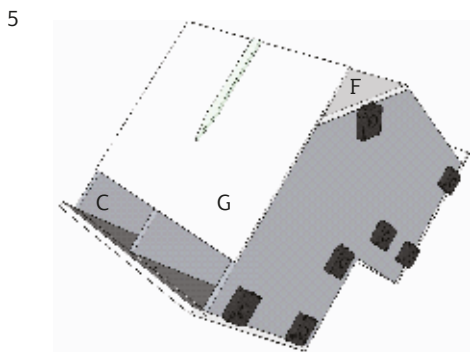

Slide back panel G into place locating in the groove in side panel.

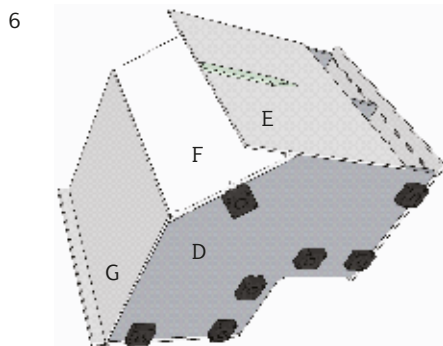

Slide back panel E into place locating in the groove in side panel A.

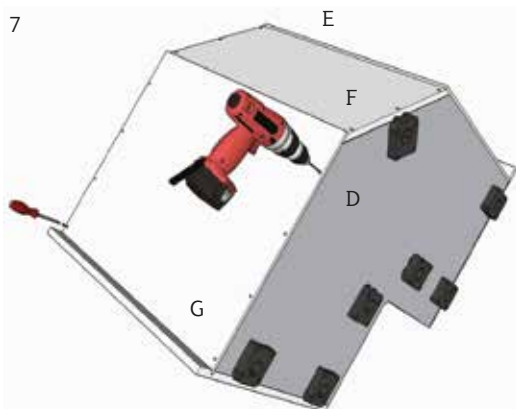

Drill pilot holes through back panels E & G and screw to rear edges of top and base panels C & D.

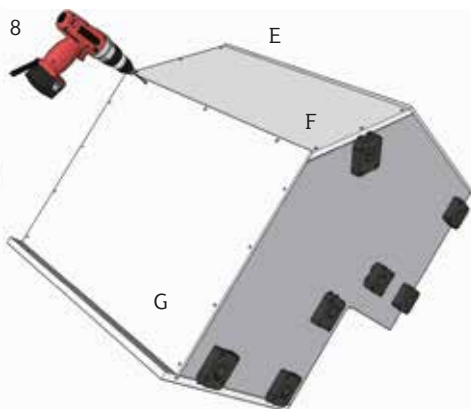

Carefully drill pilot holes through sides of back panels E & G.

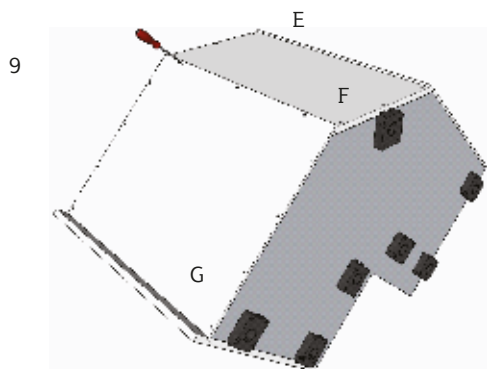

Screw fix into the diagonal edges of the rear back panel F. Use only short screws to avoid screwing through the diagonal edge.

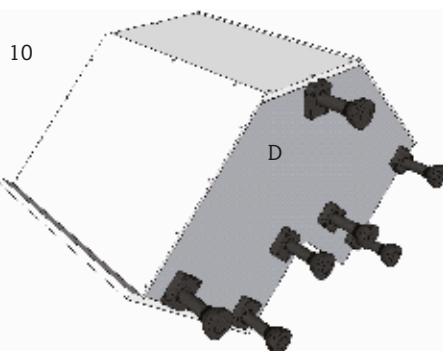

Fit legs on base panel D.

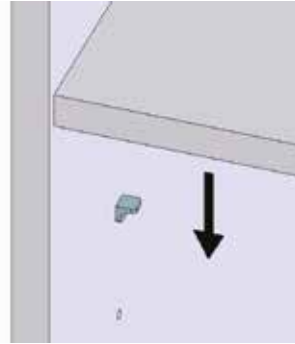
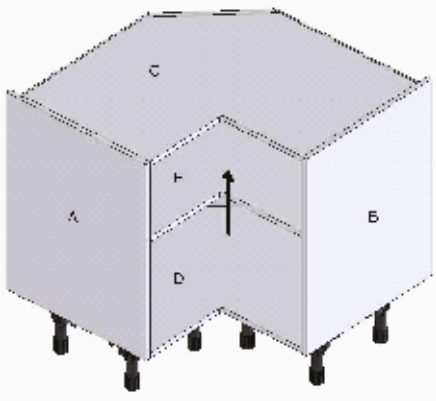

Stand unit upright and lift shelf H upwards. Insert shelf supports into holes in end panels A & B and rear diagonal back panel F, then lower shelf onto supports.

## Door Fitting: Double Hinged Doors

1

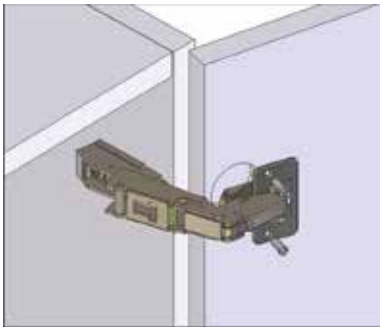

Clip 165 degree hinges onto hinge plates on either left or right hand end panel. Secure the hinge cups to holes in rear of the door with screws shown

2

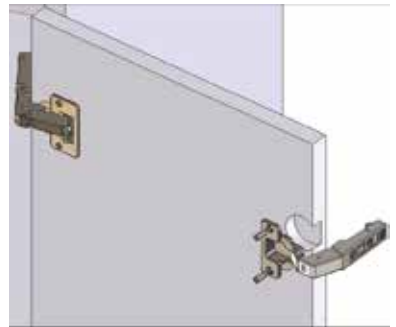

Fit corner door hinges to rear of corner doors. Secure hinge cups to holes in rear of door as shown

3

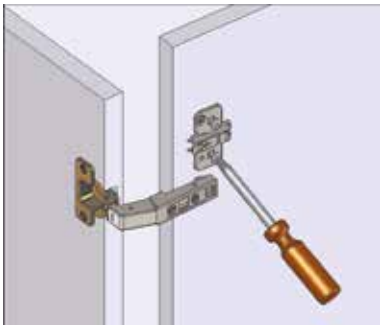

Drill rear of the second door for hinge plates as shown and screw fix

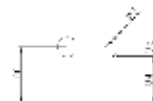
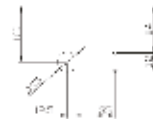

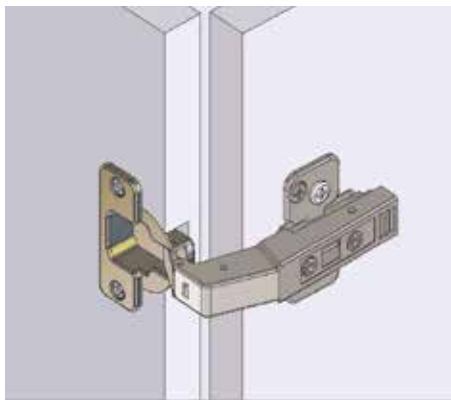

Clip hinges to the plates on the rear of the second door

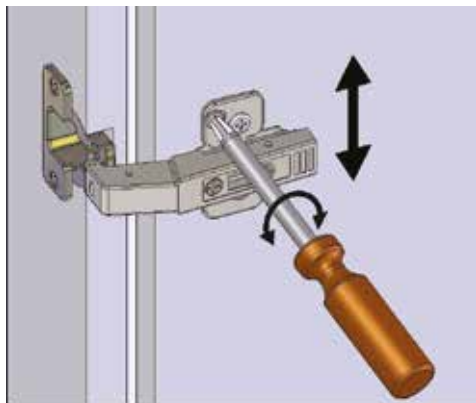

For hinge adjustment see the hinge fitting page.  
Note: - the hinge plates on the second door can be adjusted vertically by turning the plate screw as shown

# Corner Angled Base Unit Assembly

Parts supplied:

- A - Left hand end panel
- B - Right hand end panel
- C - Top panel
- D - Base panel with legs attached
- E - Left hand back panel
- F - Diagonal rear back panel
- G - Right hand back panel
- H - Shelf Panel
- J - Door with hinges

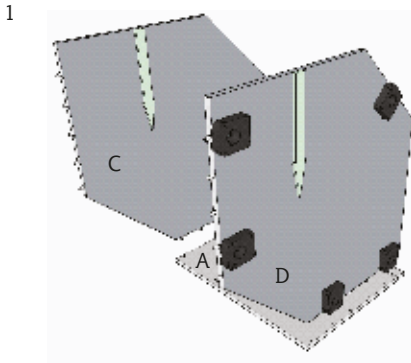
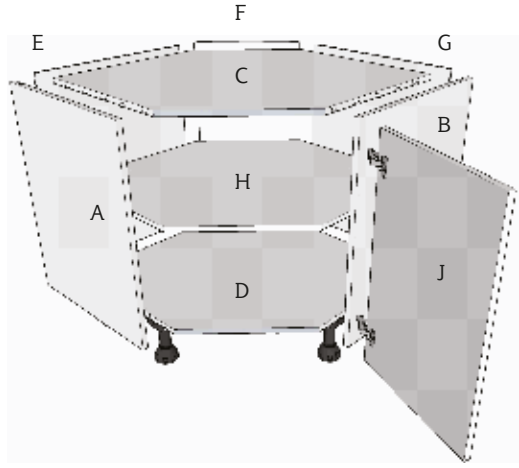

Lay left hand end panel A flat, apply glue to dowel holes top and base panels C & D, ensure that fully enter holes.

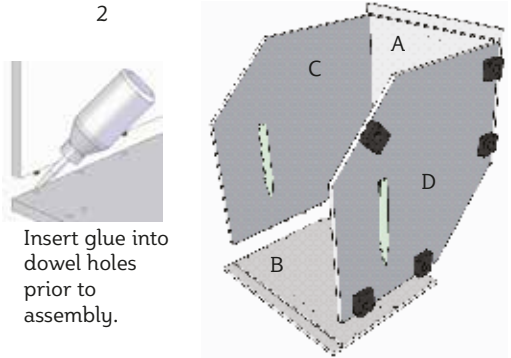

Apply glue to dowel holes in right hand end and insert B and push into place, ensure that dowels fully enter holes.

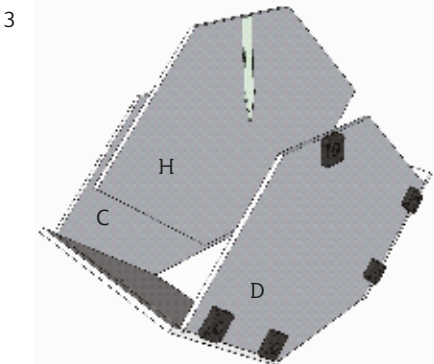

Lay unit onto its front edges. (ensuring that front edges are protected)  
Fit corner shelf panel H into place through back space.

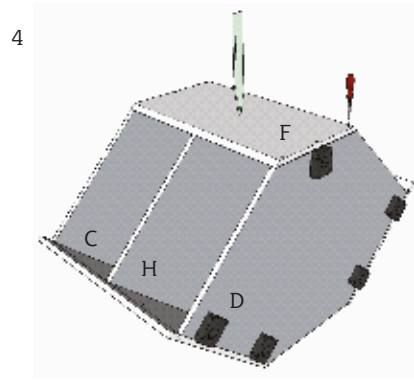

Position rear angled back panel F and screw fix to back edges of top and base panels C & D. (ensure that all edges are aligned)

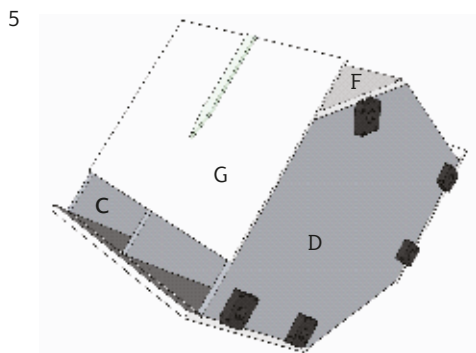

Slide back panel G into place locating in the groove in side panel A.

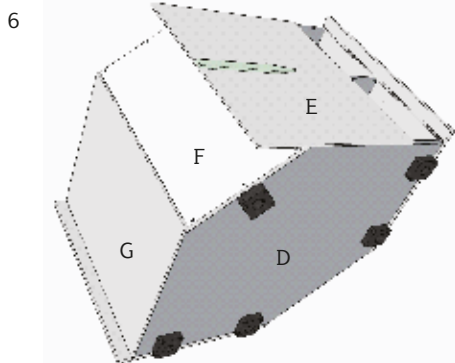

Slide back panel E into place locating in the groove in side panel B

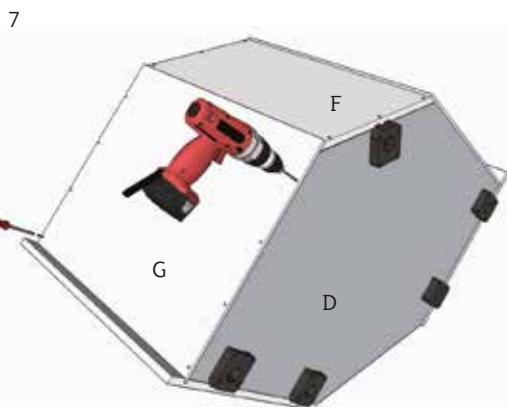

Pilot drill holes through back panels E & G and screw fix to rear edges of top and base panels C & D.

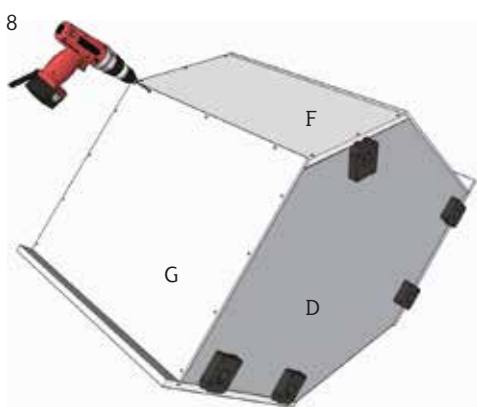

Carefully pilot drill holes through sides of back panels E & G.

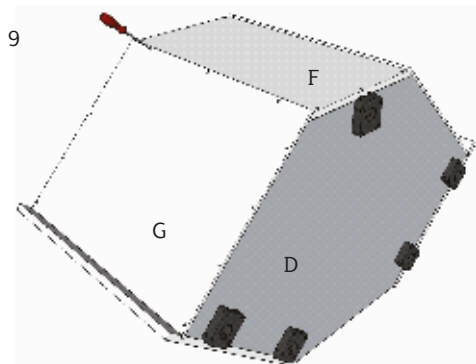

Screw fix into the diagonal edges of the rear back panel F. Use only short screws to avoid screwing through the diagonal edge.

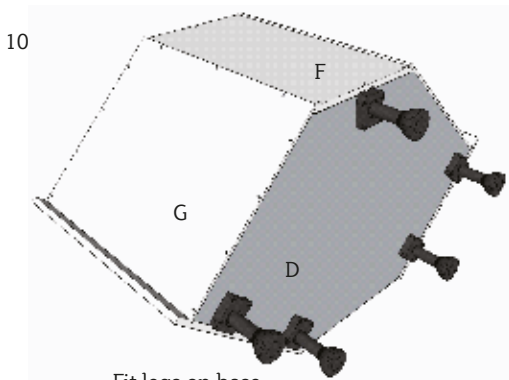

Fit legs on base panel D.

11

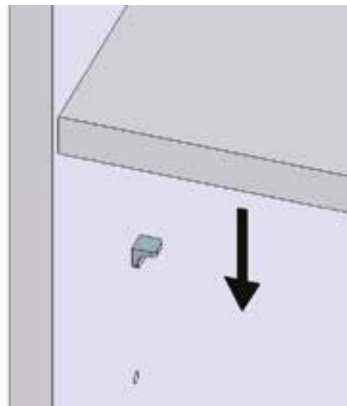
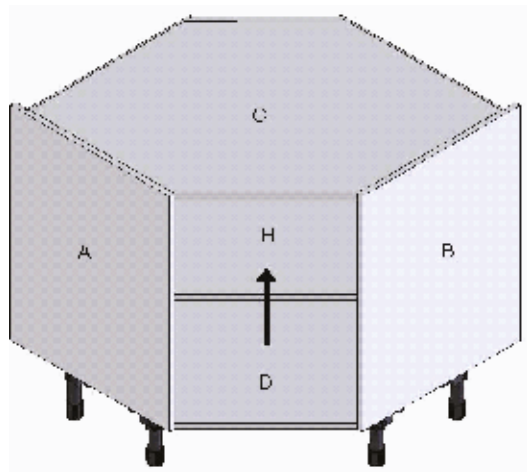

Stand unit upright and lift shelf H upwards. Insert shelf supports into holes in end panels A & B and rear diagonal back panel F, then lower shelf onto supports.

## Door Fixing

Clip hinges onto hinge plates on either left or right hand end panel. If drilling for hinges yourself follow pages 9 and 10 of the guide. Fit hinge into cup hole as drilled. For hinge adjustment please refer to pages 7 and 8 of this technical guide

# Top Box Door Drilling

Please drill your top box door as shown using a 5mm diameter drill bit. Only drill to a depth of 12mm. If your cabinet door is 600mm wide you will only need to drill one set of holes to correspond with the flap stay on your cabinet. If the cabinet is 800mm or wider both sets of drilling will be required.

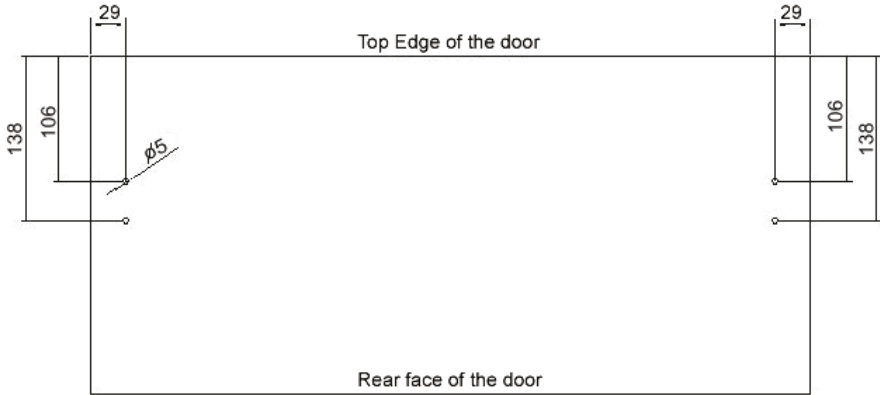

# Flap Stay Tensioning

To adjust the tension of the flap stay friction joint, you will need an allen key. Open the door to its extent turn the allen key to lock the joint open, then turn the allen key back the opposite way to release the joint enough so tat when you attempt to close the door, the joint releases and shuts under the friction of the flap stay and soft close (if fitted).

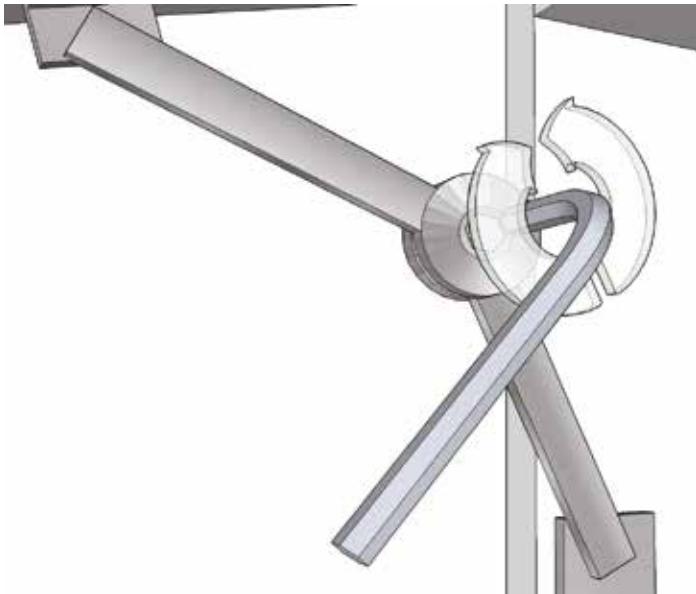





Once the cabinets are in position, level them up using the adjustment on the foot (section 1).

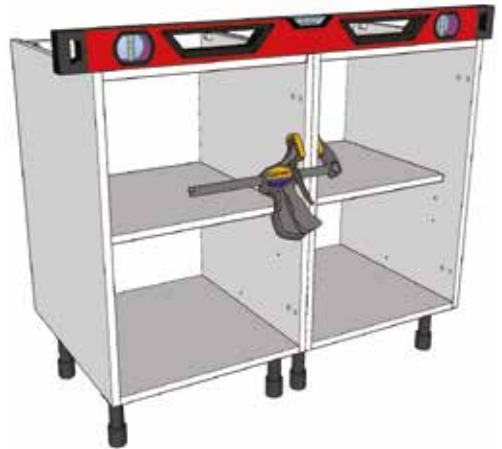

Clamp the units together



Drill the cabinets at top and bottom near to the front edge of the cabinet. The hole drilled needs to be diameter 5mm to suit the cabinet connector supplied in the fittings box.

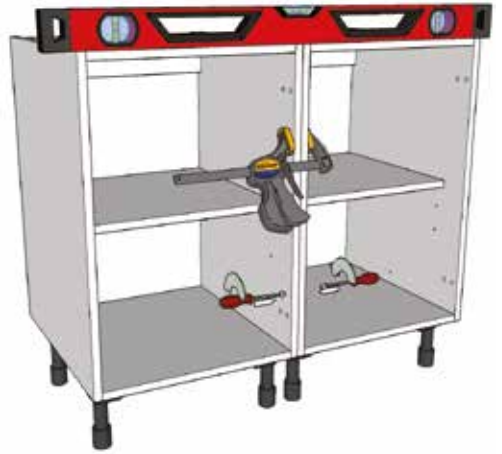

Fit the 2 part cabinet connectors in the holes drilled and tighten to secure the cabinets together.

## Cornice Fitting

- Cornice is supplied in a continuous length which will need to be cut and fitted using mitre joints where required. Fit the cornice around the top of the run of wall cabinets. Screw the cornice down to the cabinets through the cornice if possible or using an l shape bracket and screws (Not Supplied).

## Pelmet Fitting

- To fit light pelmet follow the same process as with the cornice but fit underneath the run of wall cabinets.

## Fridge/Freezer Appliance Towers

- Fridge and Freezer appliance towers are supplied with a transit back panel which will need to be removed once the cabinet is fitted in situ. This will allow the appliance to be fitted back into the cabinet correctly.

## Worktop Fitting

- Laminate and Timber worktops are supplied in pre set lengths and will need to be cut and fitted to suit the kitchen. Note worktop fixtures and fittings are not supplied.

## Revo 90 L Shape Corner Base Cabinet

- The Revo 90 Corner Base Cabinet is slightly different to the other L Shape Corner Base Cabinets. It is 18mm bigger in height to incorporate the mechanism and is fitted with 100mm legs instead of the usual 150mm legs. The cabinet will need to be packed up on these 100mm legs to get to the required height so that all of the cabinets line up underneath the worktop. They cannot be fitted with 150mm legs as this will make the cabinet too tall.

## Leg adjustment

- The cabinet legs can be adjusted -10mm down and +20mm up.

## Foil doors

- For product cleaning only use a 5% soap, 95% water (liquid soap) solution, wiping with a damp (not wet) cloth. Finally drying with a soft clean cloth. Dust with a soft cloth only.
- Do not use wax-furniture polish, abrasive or aggressive cleaners, bleach or other hypochlorate (chlorine) based cleaners, multi-purpose cleaners, dilutes, acetone, alcohol, solvent or similar product on the door as this will damage the surface.
- Cooking splashes should be wiped up immediately using a damp cloth.

## Stainless steel doors

- For product cleaning only use a 5% soap, 95% water (liquid soap) solution, wiping with a damp (not wet) cloth. Finally drying with a soft clean cloth, or alternatively clean the surface with Second Nature stainless steel cleaner or E-cloth (available from your kitchen retailer). Dust with a soft cloth only.
- Do not use wax-furniture polish, abrasive or aggressive cleaners, bleach or other hypochlorate (chlorine) based cleaners, multi-purpose cleaners, dilutes, acetone, alcohol, solvent or similar product on the door as this will damage the surface.
- Cooking splashes should be wiped up immediately using a damp cloth.
- A light coat of baby oil can be used to enhance the appearance of the door if required.

## Timber doors

- For product cleaning only use a 5% soap, 95% water (liquid soap) solution, wiping with a damp (not wet) cloth. Finally drying with a soft clean cloth. Dust with a soft cloth only, following the grain pattern of the wood.
- Do not use abrasive or aggressive cleaners, multi-purpose cleaners, dilutes, acetone, alcohol, solvent or similar products on the door as will damage the surface.
- It is advisable to use a damp (not wet) cloth to remove fingerprints and marks, followed at once with a clean and dry soft cloth. Cooking splashes should be wiped up immediately using a damp cloth.

(Note: Sanded versions of Ranges are unfinished therefore care of these doors will depend on the type of finish applied, eg paint, stain, wax etc., and you should contact your supplier of surfacing finish for care guidance)

## Vinyl doors

- For product cleaning only use a 5% soap, 95% water (liquid soap) solution, wiping with a damp (not wet) cloth. Finally drying with a soft clean cloth. Dust with a soft cloth only.
- Do not use wax-furniture polish, abrasive or aggressive cleaners, bleach or other hypochlorate (chlorine) based cleaners, multi-purpose cleaners, dilutes, acetone, alcohol, solvent or similar product on the door as this will damage the surface.
- Cooking splashes should be wiped up immediately using a damp cloth.
- If the doors are supplied with a protective film on the face they must not be directly exposed to sunlight. It is recommended the film is removed as soon as possible.

## Laminate doors

- For product cleaning only use a 5% soap, 95% water (liquid soap) solution, wiping with a damp (not wet) cloth. Finally drying with a soft clean cloth. Dust with a soft cloth only.
- Do not use wax-furniture polish, abrasive or aggressive cleaners, bleach or other hypochlorate (chlorine) based cleaners, multi-purpose cleaners, dilutes, acetone, alcohol, solvent or similar product on the door as this will damage the surface.
- Cooking splashes should be wiped up immediately using a damp cloth.

Note: Newly plastered rooms should be left to environmentally stabilize before storage and installation of doors, whatever their material.

A large, empty rectangular box with rounded corners, intended for writing notes. The box is outlined in a thin black line and occupies most of the page area below the header.