

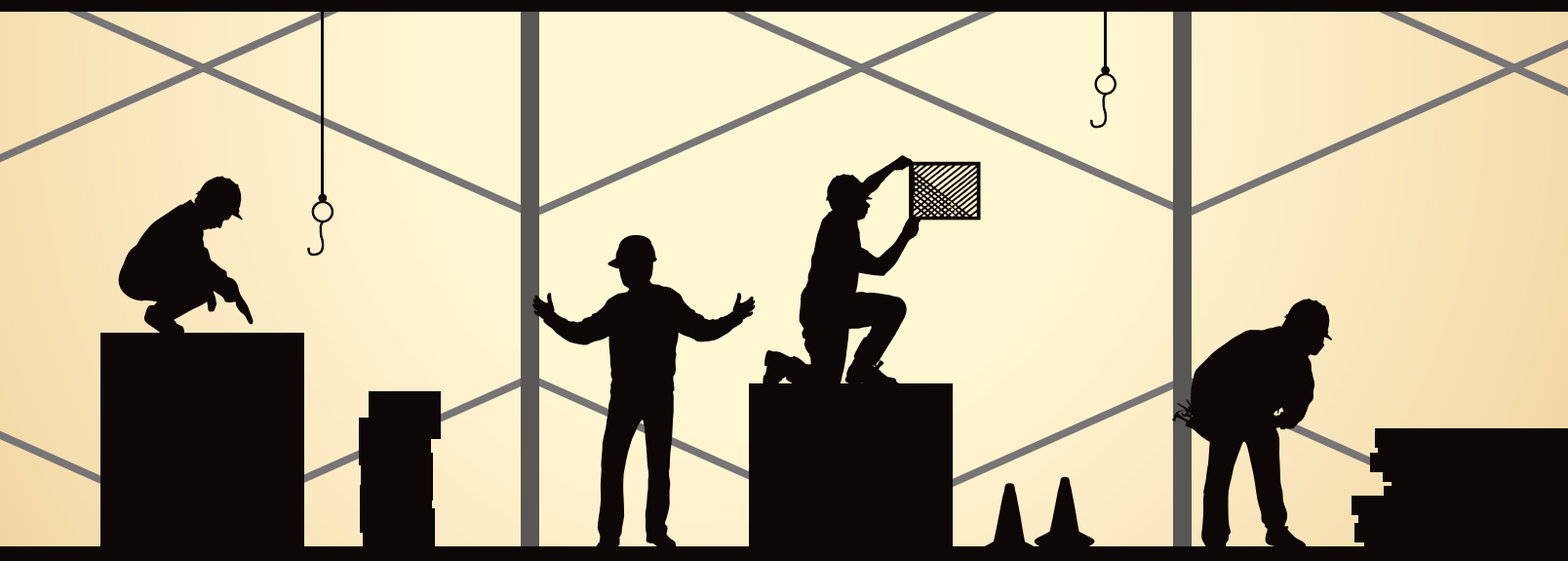

**GP**  
**Georgia-Pacific**  
Gypsum  
Building Reputations Together™

**DensGlass®**  
Shaftliner for Shaftwall/Stairwell Systems



## Product Overview

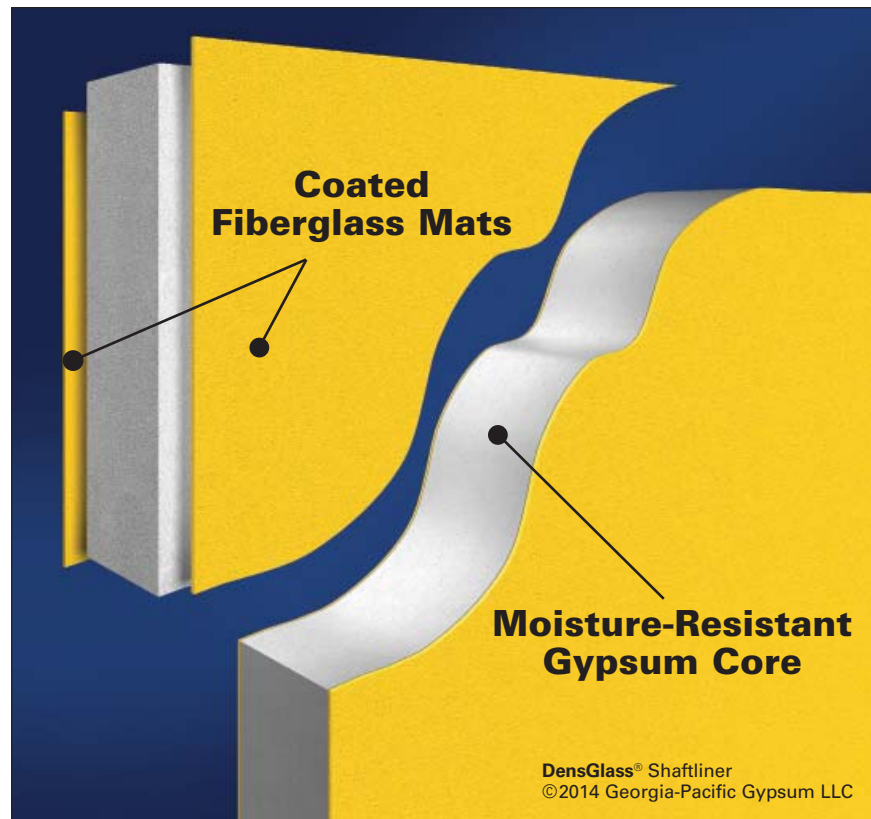

### Table of Contents

Product Overview . . . . .	2
Architectural Specifications . . . . .	4
Installation Instructions . . . . .	5
Recommendations . . . . .	6
Design Summary Vertical . . . . .	7
Design Summary Horizontal . . . . .	9
2-Hour Vertical and Horizontal Shaftwalls Around Horizontal Membranes and Ducts . . . . .	9
Hoistway Enclosures . . . . .	9
Maximum Horizontal Spans . . . . .	10
Maximum Section Properties . . . . .	10
Limiting Heights . . . . .	11
Sound Chart . . . . .	11
Door Frame Details . . . . .	12
Wall Frame Details . . . . .	13
Rails/Chute/Beam Details . . . . .	14
HVAC Duct Detail . . . . .	15
Delivery, Handling and Storage . . . . .	15
Recommendations and Limitations for Use . . . . .	15

DensGlass® Shaftliner has fiberglass mats for superior mold and moisture resistance compared to paper-faced shaftliners.

- Fiberglass mats eliminate a potential food source for mold and may reduce remediation and scheduling delays associated with paper-faced shaftliners.
- Replaces traditional paper-faced shaftliner.
- Backed with a limited warranty against delamination and deterioration for up to 12 months of exposure to normal weather conditions.\*

\*For complete warranty details, visit [www.gpgypsum.com](http://www.gpgypsum.com).

When tested, as manufactured, in accordance with ASTM D 3273, DensGlass Shaftliner panels have scored a 10, the highest level of performance for mold resistance under the ASTM D 3273 test method.

The score of 10, in the ASTM D 3273 test, indicates no mold growth in a 4-week controlled laboratory test. The mold resistance of any building product when used in actual job site conditions may not produce the same results as were achieved in the controlled, laboratory setting. No material can be considered mold proof. When properly used with good design, handling and construction practices, Dens® Brand gypsum products provide increased mold resistance compared to standard paper-faced wallboard. For additional information, go to [www.buildgp.com/safetyinfo](http://www.buildgp.com/safetyinfo).

DensGlass Shaftliner is listed as a GREENGUARD microbial-resistant product by UL Environment. This listing means DensGlass Shaftliner, which features fiberglass mats instead of paper facings used on the surface of traditional gypsum board products, resists mold growth. The microbial-resistant test is based on D 6329, a guide set by ASTM International, which develops testing guidelines and procedures for building materials, products, systems and services.

## DensGlass® Shaftliner Panel

In buildings around the world, our lightweight, maintenance-free shaftwall/stairwell enclosures serve as the perfect substitute for heavy and expensive masonry construction in building cores. In addition, DensGlass Shaftliner shaftwall/stairwell assemblies save space, go up quickly and don't delay construction during cold weather.

Space-saving DensGlass Shaftliner shaftwall/stairwell enclosures are designed for elevator and air shafts, stairwells and mechanical services in industrial areas where greater heights are common and as firewalls between office, warehouse and manufacturing areas. They are also used as horizontal membranes for corridor and stairway ceilings and across mechanical equipment where fire ratings are required and normal suspension support may be difficult.

### Easy Installation

Because the shaftwall assemblies are built from one side only, there's no need to access the inside of the shaft. The strong, C-T, C-H or I steel members go up quickly. Most configurations require only two steel components and two types of gypsum board. That makes the systems ideal for furred chases and interior partitions where fire ratings are required for exterior walls and access is restricted. Engineered for durability, the systems withstand the air-pressure surges of high-speed elevators as well as the lateral impact of stairway doors.

### Built-In Economy

Gypsum shaftwall/stairwell systems typically cost less than masonry. Cost savings can be even greater when masonry requires a finish. Contractors also save money, since the shaftwall/stairwell enclosures don't require expensive structural framing or concrete construction.

### Building Code

Georgia-Pacific Gypsum shaftwall/stairwell systems conform to the requirements of the IBC which now contain the addition of two model building and fire code changes that impact the stairwell shaft construction. An additional (third) exit stairway is now required for buildings more than 420 feet high. Hardening of exit stairway and passageway enclosures, and elevator shaft enclosures, are required for all buildings more than 420 feet high and for buildings 75-420 feet high where failure of the enclosure would substantially jeopardize human life; and in essential facilities such as hospitals. This assembly may also require the installation of DensArmor Plus® Abuse-Resistant or Impact-Resistant panels.

### Reliable Steel Components

The two primary framing components in the DensGlass Shaftliner shaftwall/stairwell system are slotted C-T, C-H or I studs and J tracks, manufactured from galvanized steel that meets the requirements of ASTM C 645 and A 924.

The 2-1/2" (64 mm) steel framing system retains the popular 3-1/2" (89 mm) wall thickness with a two-hour fire rating (see pages 7 and 8) to accommodate standard door framing dimensions. The steel stud offers a unique feature — slotting in the web of the stud. Tests have demonstrated that these slots effectively improve resistance to thermal and noise transmissions.

The 2-1/2" (64 mm) stud provides a 1-1/2" (38 mm) air cavity for services. Studs are friction-fitted between top and bottom J tracks. Use J tracks for all closure details, including duct and door openings, abutments, intersections, etc. No other special metal components are required.

Studs are automatically spaced 24" (610 mm) o.c. maximum with our special shaftliner panels.

*The data relating to fire and sound tested assemblies is based on the characteristics, properties and performance of materials and systems obtained under controlled test conditions as set forth under the appropriate ASTM standard, such as E 119 (fire), E 90 (sound) or E 72 (structural).*

---

## Georgia-Pacific Gypsum and Sustainability

Georgia-Pacific Gypsum's definition of sustainability is meeting the needs of society today without jeopardizing our ability to do so in the future. We are committed to using resources efficiently to provide innovative products and solutions that meet the needs of customers and society, while operating in a manner that is environmentally and socially responsible, and economically sound.

We continue to focus on:

- Improving energy efficiency at our manufacturing plants
- Seeking out opportunities to reduce water use, and to reuse water more efficiently
- Finding cost effective ways to further reduce air emissions
- Recovering and reusing materials that otherwise would end up in landfills.

Green building codes, standards, and programs are establishing themselves across the country. They promote the use of products that contribute to the performance of the building, along with minimizing environmental and human health impacts over the life of the building or home. Because we embrace product performance and operate in an environmentally, socially, and economically sound manner, owners and architects can feel good about the structures they build using our products.

Many of our products contribute to LEED® and other green building codes, standards, or program credits or requirements. To find out more, please refer to the Sustainable Materials Data Sheets (SMDS) at [www.gpgypsum.com](http://www.gpgypsum.com) for recycled content, regional materials, and low emitting materials information or use our on-line LEED calculator to calculate contribution for a specific credit. For general information on sustainability, click the "Sustainability" tab on the website.

---

## Architectural Specifications

Georgia-Pacific Gypsum's 3-part guide specifications are downloadable, as rewritable Microsoft® Word documents, in both CSI and ARCOM MasterSpec® formats. Georgia-Pacific Gypsum specifications and 3-D Revit® compatible models can be found at [www.gpdesignstudio.com](http://www.gpdesignstudio.com). Downloadable specifications are also available online from Building Systems Design, Inc. at [www.bssoftlink.com](http://www.bssoftlink.com), and ARCOM Product Masterspec at [www.masterspec.com](http://www.masterspec.com).

## Installation Instructions

1. Lay out per construction drawings. Secure J track as perimeter framing on floor and plumb to ceiling and sides. Attach with suitable fasteners, spaced not more than 24" (610 mm) o.c.
2. Plan the stud layout 24" (610 mm) o.c. and adjust the spacing at either end so that the terminal stud will not fall closer than 8" (203 mm) from the end (is recommended). Pieces less than 8" (203 mm) may pose handling and flexibility concerns such as cracking and breaking.
3. 1" (25.4 mm) DensGlass® Shaftliner panels should be cut no more than 3/4" (19 mm) for WHI designs or 1" (25.4 mm) for UL designs less than the total height of the framed section. Plumb the first panel flush against the web of the J track and secure with 1-5/8" (41 mm) Type S screws 24" (610 mm) o.c. or bend out tabs in J track to secure panels in place. DensGlass Shaftliner panels can be installed with either side facing out, however some authorities may require labeling to be visible.
4. Insert a C-T, C-H or I stud, cut 3/4" (19 mm) less than the overall height, into the top and bottom J tracks and fit tightly over the previously installed 1" (25.4 mm) panel.
5. Install the next 1" (25.4 mm) DensGlass Shaftliner panel inside the J tracks and within the tabs of the C-T, C-H or I stud. Note that the edges of the panel are beveled to help guide the panel into the slotted and tabbed section of the stud.
6. Progressively install succeeding studs and panels as described above until the wall section is enclosed. The final panel section may be secured with 1-5/8" (41 mm) Type S screws or tabs from the J track at 24" (610 mm) o.c.
7. For doors, ducts or other large penetrations or openings, install J track as perimeter framing. Use true 20-gauge (33 mils) track with a 3" (76 mm) back leg for elevator doors and block cavity with 12" (305 mm) wide gypsum board filler strips for doors exceeding 7'-0" (2134 mm) height. Attach metal intersections with a 3/8" (9.5 mm) pan head screw.
8. 1" (25.4 mm) DensGlass Shaftliner panels may be abutted, spliced or stacked within the cavity. The shorter panel should be minimum 2' (610 mm) long or longer to engage two stud tabs on each panel edge. Joints of adjacent panels should be alternately stacked or staggered to prevent a continuous horizontal joint. This is not required for UL V473 1 hour Shaftwall.
9. Fire tests were conducted without back blocking of shaftliner joints. Install factory cut edges back to back for all WHI designs and UL 1 hour V473.
- \*10. For WHI GP/WA 120-01 finished one side, install the base layer of 1/2" (12.7 mm) ToughRock® Fireguard C® or 1/2" (12.7 mm) DensArmor Plus® Fireguard C® gypsum board horizontally with 1" (25 mm) Type S or S-12 screws spaced 24" (610 mm) o.c. starting 3" (76 mm) from top and bottom. (5/8" (15.9 mm) DensArmor Plus® Fireguard® gypsum board may be used in lieu of 1/2" (12.7 mm) ToughRock Fireguard C gypsum board, if desired.) The horizontal joints should be offset from any splice joints in the shaftliner panels by at least 12" (305 mm). Install the face layer vertically with 1-5/8" (41 mm) Type S or S-12 screws spaced 12" (305 mm) o.c. starting 6" (152 mm) from top and bottom. (All edge and end joints should be offset from the base layer by 24" (610 mm) o.c.)
- \*11. For WHI GP/WA 120-02, finished both sides, each side must be installed vertically with joints offset, 1" (25 mm) Type S or S-12 screws spaced 12" (305 mm) starting 6" (152 mm) from top and bottom. Offset edges and ends on opposite sides 24" (610 mm) o.c.
- \*12. For WHI GP/WA 60-01, finished one side, apply the 5/8" (15.9 mm) ToughRock® Fireguard X™ or 5/8" (15.9 mm) DensArmor Plus Fireguard gypsum board horizontally or vertically with 1" (25 mm) Type S or S-12 screws spaced 12" (305 mm) o.c.
- \*13. For UL V473, 2 hour finished one side, install the base layer of 5/8" (15.9 mm) ToughRock® Fireguard X™ or 5/8" (15.9 mm) DensArmor Plus Fireguard horizontally or vertically with 1" (25 mm) Type S screws spaced 24" (610 mm) o.c. Face layer shall be applied horizontally or vertically, attached with 1-5/8" (41 mm) Type S screws spaced 12" (305 mm) o.c. (All end and edge joints should be offset from the base layer by 24" (610 mm) o.c.)
- \*14. For UL V473, 1 hour, apply 5/8" (15.9 mm) ToughRock® Fireguard X™ or 5/8" (15.9 mm) DensArmor Plus Fireguard gypsum board horizontally or vertically. Vertical joints centered over studs. Attach with 1" (25 mm) Type S or S-12 screws spaced 8" (203 mm) o.c.
15. When used as HVAC ducts, consult with HVAC engineer regarding level of caulking and sealant required. All joints on face layers are to be taped and finished and fasteners finished with joint compound meeting ASTM C 475. All penetration openings are to be filled with firestopping sealants.
16. For more information on firestopping through penetrations in shaftwall systems or head of wall shaftwall details, consult the UL directory or other fire testing agencies' listings.

*\*Consult the UL or WHI listing or test report for complete assembly information.*

See individual fire test listings for approved studs. (Drawings are not to scale.)

### C-T Stud Detail

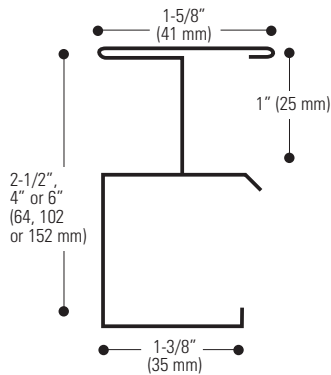

### C-H Stud Detail

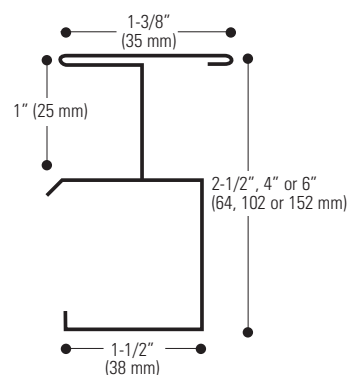

### I Stud Detail

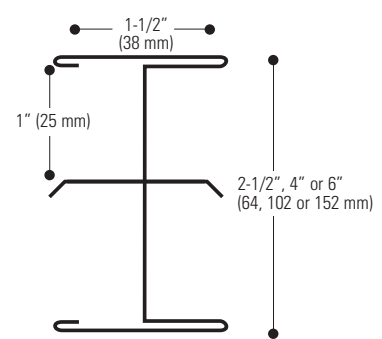

### J Track

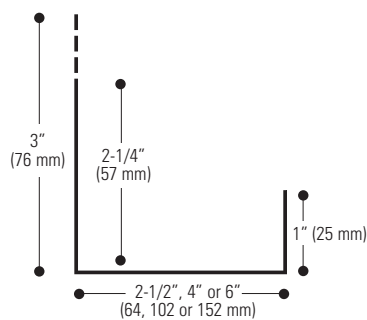

### J-L Corner

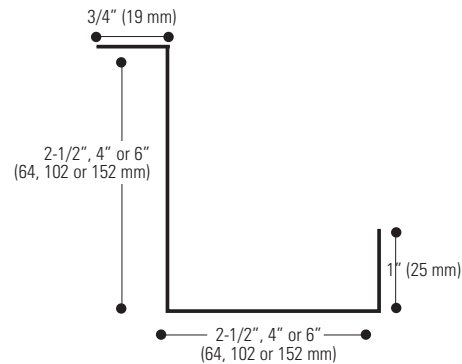

## Recommendations

- Use a fastening plate to secure the J track whenever fasteners are closer than 4" (102 mm) to the end of the assembly. Setting the plate at the time of concrete construction will avoid spalling by mechanical fasteners.
- In structural steel-frame construction, install J track sections before applying spray-on fireproofing.
- Items to be anchored to the wall (cabinets, sinks, handrails, etc.) should be fastened to the C-T, C-H or I studs or to plates secured behind or between layers of 1/2" (12.7 mm) ToughRock® Fireguard C® gypsum board. (See hand rail illustration on page 14.)
- Joint compounds should be applied at ambient temperatures above 50°F (10°C) with adequate ventilation.
- Use Type S screws for true 25-gauge (18 mils) steel framing. Use Type S-12 screws for true 20-gauge (33 mils) (or heavier) steel framing.
- It is important that the job structural engineer approves the type, size and maximum spacing of track fasteners to meet the design load requirements.



## Design Summary Vertical

DensGlass® Shaftliner is UL and ULC classified as **Type DGUSL** and included in numerous assembly designs investigated by UL and ULC for hourly fire resistance ratings.

In addition, DensGlass Shaftliner is classified as “Type X” in accordance with ASTM C 1658 and may replace 1” gypsum shaftliner panels specified as Type X in generic fire-rated wall assemblies. Generic systems in the GA-600 Fire Resistance Design Manual are applicable to the products of any manufacturer, including Georgia-Pacific Gypsum, provided they meet certain standards set forth in such manual, such as Type X gypsum board per applicable ASTM standard with specified thickness and size described in the design. “Type X” as used in this technical guide designates gypsum board manufactured and tested in accordance with specific ASTM standards for increased fire resistance beyond regular gypsum boards. Please consult the ASTM standard for the specific product (for example, ASTM C 1658 for glass mat gypsum panels) for further information and significance of use.

**The following design assemblies are for illustrative purposes only. Consult the appropriate fire resistance directory or test report for complete assembly information. For additional fire safety information concerning DensGlass Shaftliner, visit [www.buildgp.com/safetyinfo](http://www.buildgp.com/safetyinfo).**

**Proprietary GA-600 Designs:** Assemblies listed as proprietary in the GA-600 Fire Resistance Design Manual only list one product per manufacturer and may not include all products referenced in the illustrations below. Please consult the specified UL, ULC, cUL or other fire listing or test for a complete list of approved products.

### 1-Hour Fire Rating

Design Reference: WHI Design GP/WA 60-01 GA WP 6855

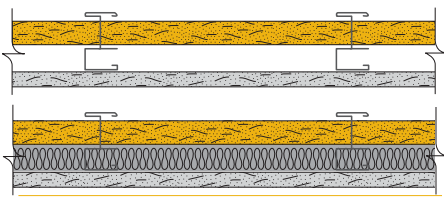

### 43 STC Sound Trans.

Test Reference: RAL TL 09-357  
Approx. Weight: 7 psf (34 Kg/m<sup>2</sup>)

Fiberglass sound insulation thickness is 1” (25 mm), 2-1/2” (64 mm) and 3-1/2” (89 mm) for C-T, C-H or I studs of 2-1/2” (64 mm), 4” (102 mm) and 6” (152 mm) respectively. Finished one side. Components: 1” (25.4 mm) DensGlass Shaftliner panel, studs and one layer of 5/8” (15.9 mm) ToughRock® Fireguard X™ or 5/8” (15.9 mm) DensArmor Plus® Fireguard® gypsum board installed vertically.

C-T, C-H or I Stud	2-1/2” (64 mm)	4” (102 mm)	6” (152 mm)
Wall Thickness	3-1/8” (80 mm)	4-5/8” (118 mm)	6-5/8” (168 mm)

### 1-Hour Fire Rating

Design Reference: UL V473, cUL V473, GA WP 6851

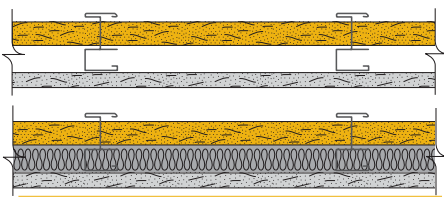

### 43 STC Sound Trans.

Test Reference: RAL TL 09-357  
Approx. Weight: 7 psf (34 Kg/m<sup>2</sup>)

Fiberglass sound insulation thickness is 1” (25 mm), 2-1/2” (64 mm) and 3-1/2” (89 mm) for C-T or C-H stud(s) of 2-1/2” (64 mm), 4” (102 mm) and 6” (152 mm) respectively. Finished one side. Components: 1” (25.4 mm) DensGlass Shaftliner panel, studs and one layer of 5/8” (15.9 mm) ToughRock® Fireguard X™ or 5/8” (15.9 mm) DensArmor Plus® Fireguard gypsum board installed vertically.

C-T or C-H Stud	2-1/2” (64 mm)	4” (102 mm)	6” (152 mm)
Wall Thickness	3-1/8” (80 mm)	4-5/8” (118 mm)	6-5/8” (168 mm)

### 2-Hour Fire Rating

Design Reference: UL V473, cUL V473, GA WP 7054

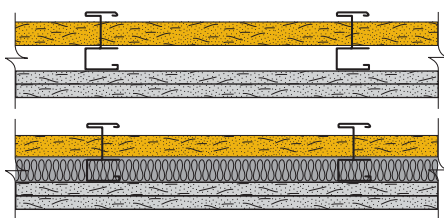

### 51 STC Sound Trans.

Test Reference: RAL TL 09-358  
Approx. Weight: 10 psf (49 Kg/m<sup>2</sup>)

Fiberglass sound insulation thickness is 1” (25.4 mm), 2-1/2” (64 mm) and 3-1/2” (89 mm) for C-T or C-H studs of 2-1/2” (64 mm), 4” (102 mm) and 6” (152 mm) respectively. Finished one side. Components: 1” (25.4 mm) DensGlass Shaftliner panel, C-T or C-H studs and two layers of 5/8” (15.9 mm) DensArmor Plus Fireguard or 5/8” (15.9 mm) ToughRock® Fireguard X™ gypsum board installed horizontally for base layer and vertically for face layer. Edges and ends offset 24” (610 mm) o.c.

C-T or C-H Stud	2-1/2” (64 mm)	4” (102 mm)	6” (152 mm)
Wall Thickness	3-3/4” (95 mm)	5-1/4” (133 mm)	7-1/4” (184 mm)

## Design Summary Vertical continued

### 2-Hour Fire Rating

Design Reference: UL V473, ULC W481, cUL V473, GA WP 7059

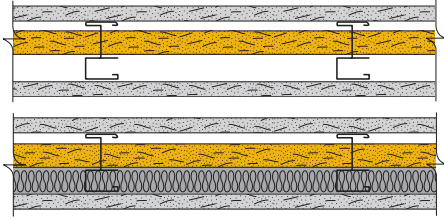

### 46 STC Sound Trans.

Test Reference: RAL TL 09-359  
Approx. Weight: 10 psf (49 Kg/m<sup>2</sup>)

Fiberglass sound insulation thickness is 1" (25.4 mm), 2-1/2" (64 mm), and 3-1/2" (89 mm) for C-T or C-H studs of 2-1/2" (64 mm), 4" (102 mm), and 6" (152 mm) respectively. Finished both sides. Components: 1" (25.4 mm) DensGlass® Shaftliner, C-T or C-H studs and 5/8" (15.9 mm) ToughRock® Fireguard X™ or 5/8" (15.9 mm) DensArmor Plus® Fireguard® board installed horizontally or vertically. Edges and ends offset 24" (610 mm) o.c.

C-T or C-H Stud	2-1/2" (64 mm)	4" (102 mm)	6" (152 mm)
Wall Thickness	3-3/4" (95 mm)	5-1/4" (133 mm)	7-1/4" (184 mm)

### 2-Hour Fire Rating

Design Reference: WHI Design GP/WA 120-01, GA WP 7054.4

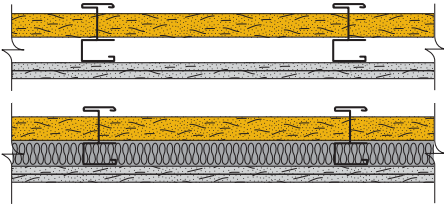

### 50 STC Sound Trans.

Test Reference: RAL TL 09-360  
Approx. Weight: 9 psf (44 Kg/m<sup>2</sup>)

Fiberglass sound insulation thickness is 1" (25 mm), 2-1/2" (64 mm) and 3-1/2" (89 mm) for C-T, C-H or I studs of 2-1/2" (64 mm), 4" (102 mm) and 6" (152 mm) respectively. Finished one side. Components: 1" (25.4 mm) DensGlass® Shaftliner panel, C-T studs and two layers of 1/2" (12.7 mm) DensArmor Plus® Fireguard C® or 1/2" (12.7 mm) ToughRock® Fireguard C® gypsum board installed horizontally for base layer and vertically for face layer. Edges and ends offset 24" (610 mm) o.c.

C-T, C-H or I Stud	2-1/2" (64 mm)	4" (102 mm)	6" (152 mm)
Wall Thickness	3-1/2" (89 mm)	5" (127 mm)	7" (178 mm)

### 2-Hour Fire Rating

Design Reference: WHI Design GP/WA 120-02, GA WP 7073

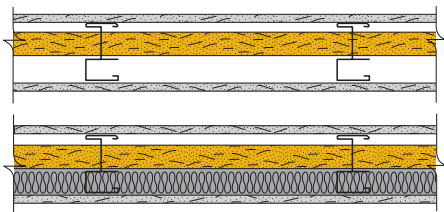

### 46 STC Sound Trans.

Test Reference: RAL TL 09-359  
Approx. Weight: 9 psf (44 Kg/m<sup>2</sup>)

Fiberglass sound insulation thickness is 1" (25 mm), 2-1/2" (64 mm) and 3-1/2" (89 mm) for C-T, C-H or I studs of 2-1/2" (64 mm), 4" (102 mm) and 6" (152 mm) respectively. Finished both sides. Components: 1" (25.4 mm) DensGlass® Shaftliner, C-T or C-H studs and 1/2" (12.7 mm) DensArmor Plus Fireguard C or 1/2" (12.7 mm) ToughRock Fireguard C gypsum board installed horizontally or vertically. Edges and ends offset 24" (610 mm) o.c.

C-T, C-H or I Stud	2-1/2" (64 mm)	4" (102 mm)	6" (152 mm)
Wall Thickness	3-1/2" (89 mm)	5" (127 mm)	7" (178 mm)

### 3-Hour Fire Rating

Design Reference: WHI GP/WA 180-01, GA WP 7422

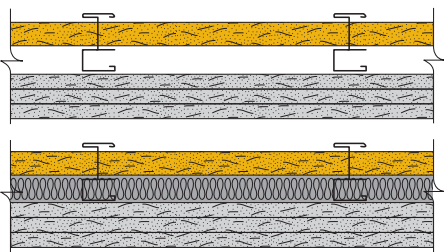

### 51 STC Sound Trans.

Test Reference: RAL TL 09-358  
Approx. Weight: 12 psf (59 Kg/m<sup>2</sup>)

Fiberglass sound insulation thickness is 1" (25 mm), 2-1/2" (64 mm) and 3-1/2" (89 mm) for C-T, C-H or I studs of 2-1/2" (64 mm), 4" (102 mm) and 6" (152 mm) respectively. Finished one side. Components: 1" (25.4 mm) DensGlass Shaftliner panel, studs and three layers of 5/8" (15.9 mm) ToughRock Fireguard C gypsum board or 5/8" (15.9 mm) DensArmor Plus Fireguard C installed horizontally or vertically per test reference. Edges and ends offset 24" (610 mm) o.c.

C-T, C-H or I Stud	2-1/2" (64 mm)	4" (102 mm)	6" (152 mm)
Wall Thickness	4-3/8" (111 mm)	5-7/8" (149 mm)	7-7/8" (200 mm)



## Design Summary Horizontal – Shaftwall Assemblies

### 2-Hour Fire Rating

Design Reference: WHI-495-PSH-0128

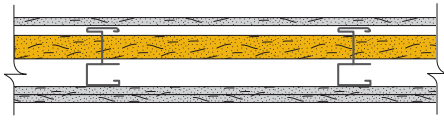

Approx. Weight: 11 psf (54 Kg/m<sup>2</sup>)

Designed for ceiling or duct shaft and composed of 1" (25.4 mm) DensGlass® Shaftliner panel supported by 2-1/2" (64 mm), 4" (102 mm) or 6" (152 mm) C-T studs and three layers of 1/2" (12.7 mm) ToughRock® Fireguard C® or 1/2" (12.7 mm) DensArmor Plus® Fireguard C® gypsum board.

### 2-Hour Fire Rating

Design Reference: WHI-495-PSH-0153, WHI-495-PSH-0197

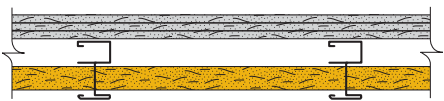

Approx. Weight: 11 psf (54 Kg/m<sup>2</sup>)

Designed to separate a room from structure or space above and composed of 1" (25.4 mm) DensGlass Shaftliner panel supported by 2-1/2" (64 mm), 4" (102 mm) or 6" (152 mm) C-T studs and three layers of 1/2" (12.7 mm) ToughRock Fireguard C or 1/2" (12.7 mm) DensArmor Plus Fireguard C gypsum board.

### 2-Hour Fire Rating

Design Reference: WHI-495-PSH-0183, WHI-495-PSH-0196, WHI Design GP/CC 120-01

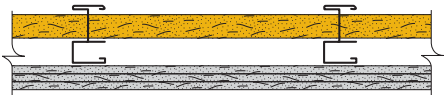

Approx. Weight: 11 psf (54 Kg/m<sup>2</sup>)

Designed to separate a room from structure or space above and composed of 1" (25.4 mm) DensGlass Shaftliner panel supported by 2-1/2" (64 mm), 4" (102 mm) or 6" (152 mm) C-T studs and three layers of 1/2" (12.7 mm) ToughRock Fireguard C or 1/2" (12.7 mm) DensArmor Plus Fireguard C gypsum board.

## 2-Hour Vertical and Horizontal Shaftwalls Around Horizontal Membranes and Ducts

### DensGlass® Shaftliner Components

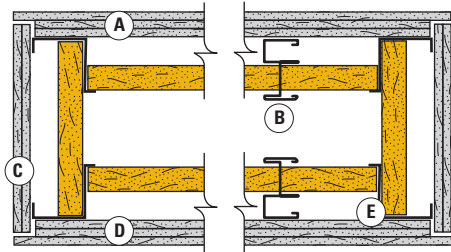

- A. WHI 495-PSH-0153
- B. C-T, C-H or I stud
- C. WHI GP/WA 120-01
- D. WHI GP/CC 120-01
- E. J-L corner or back to back J

1/2" (12.7 mm) DensArmor Plus® Fireguard C®, 1/2" (12.7 mm) ToughRock® Fireguard C®, 5/8" (15.9 mm) DensArmor Plus® Fireguard® and 5/8" (15.9 mm) ToughRock® Fireguard X™ gypsum boards are manufactured to meet or exceed applicable sections of ASTM C 1658 and ASTM C 1396.

These products may be used for other related corridor and party walls, often eliminating the need to stock more than one type at the job site. Depending on the fire rating, one or more layers are installed on the C-T studs with drywall screws. Screws are not required to secure either layer to the top or bottom J tracks. Refer to the sections covering specific fire ratings for the number of layers required and the detailed attachment procedures.

1" (25.4 mm) DensGlass Shaftliner panels are manufactured to meet or exceed ASTM C 1658 and ASTM C 1396. Panels are made in a normal width of 23-7/8" (606 mm) with double beveled edges. DensGlass Shaftliner panels install easily within the flanges of the C-T studs. Screws may be installed at the top J track to hold the panel in place.

Drive 1-5/8" (41 mm) Type S screws 24" (610 mm) o.c. maximum through the shaftliner to the J track at corner and abutments or use the turnout tabs to secure the panel in place.

These details are typical uses of the 2-hour vertical wall system, as well as horizontal membranes for 2-hour ceiling and duct protection.

## DensGlass® Shaftliner Assemblies Meet IBC Requirement for Interior Exit Stairways and Elevator Hoistway Enclosures

Two DensGlass Shaftliner assemblies (see next page) have been shown to meet the prescriptive requirements in Section 403.2.3 of the International Building Code (IBC) structural integrity of interior exit stairway enclosures and elevator hoistway enclosures. The code calls for the "hardening" of these wall assembly enclosures by meeting both soft body and hard body impact criteria as measured by ASTM C 1629.

This prescriptive requirement (meeting soft body and hard body impact requirements) in section 403.2.3 applies to high-rise buildings that are considered high occupancy or essential as defined by code (Category III and IV), and all buildings that are more than 420 feet (128 m) in height.

## Stairways and Elevator Hoistway Enclosures *continued*

### Design Reference UL V 473

Two 2-hour fire-rated assemblies, consisting of 5/8" gypsum panels and 1" gypsum shaftliner panels as shown.

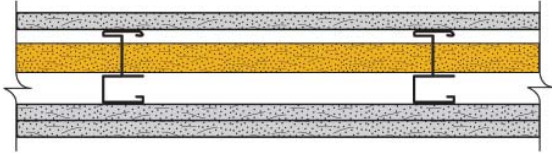

Summary of test results for Single Layer on Shaftliner Side:  
DensGlass® Shaftliner ASTM C 1629 Testing

Shaft Side Single Layer <sup>†</sup>	Soft Body Impact Level (0-3)	Hard Body Impact Level (0-3)
DensArmor Plus® Impact-Resistant	3	3

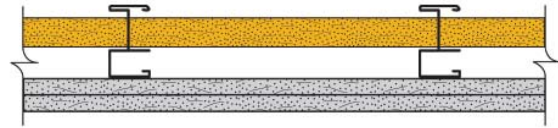

Summary of test results for 2 Layer on Tenant Side:  
DensGlass Shaftliner ASTM C 1629 Testing

Tenant Side Double Layer <sup>†</sup>	Soft Body Impact Level (0-3)	Hard Body Impact Level (0-3)
DensArmor Plus® Impact-Resistant/ DensArmor Plus Impact-Resistant	3*	3
DensArmor Plus Impact-Resistant/ ToughRock® Fireguard X™ Abuse-Resistant	3*	3
DensArmor Plus Impact-Resistant/ DensArmor Plus Abuse-Resistant	3*	3
DensArmor Plus Impact-Resistant/ ToughRock® Fireguard X™	3	3
DensArmor Plus Impact-Resistant/ DensArmor Plus® Fireguard®	3	3

<sup>†</sup> Each layer comprised of 5/8" panel.

\* Determined by Timber Products Inspection, Inc. (testing company) based on testing of the weakest components.

## Maximum Horizontal Spans

When used as a horizontal membrane, the stud length should not exceed those in the following table.

C-T Stud	Nominal Gauge	Vertical Shaftwall 1-Hour*		Vertical Shaftwall 2-Hour*		Horizontal Shaftwalls 2-Hour	
		L/240	L/360	L/240	L/360	L/240	L/360
2-1/2" (64 mm)	25 (18 mils)	9' 4" (2845 mm)	8' 2" (2489 mm)	8' 8" (2642 mm)	7' 7" (2311 mm)	8' 1" (2464 mm)	7' 1" (2159 mm)
2-1/2" (64 mm)	20 (33 mils)	11' 1" (3378 mm)	9' 8" (2946 mm)	10' 4" (3150 mm)	9' 0" (2743 mm)	9' 8" (2946 mm)	8' 5" (2565 mm)
4" (102 mm)	25 (18 mils)	13' 2" (4013 mm)	11' 6" (3505 mm)	12' 4" (3759 mm)	10' 9" (3277 mm)	11' 6" (3505 mm)	10' 0" (3048 mm)
4" (102 mm)	20 (33 mils)	15' 6" (4724 mm)	13' 7" (4140 mm)	14' 7" (4445 mm)	12' 9" (3886 mm)	13' 7" (4140 mm)	11' 10" (3607 mm)
6" (152 mm)	25 (18 mils)	17' 11" (5461 mm)	15' 8" (4775 mm)	16' 9" (5105 mm)	14' 7" (4445 mm)	15' 7" (4750 mm)	13' 7" (4140 mm)
6" (152 mm)	20 (33 mils)	21' 1" (6426 mm)	18' 6" (5639 mm)	19' 9" (6020 mm)	17' 3" (5258 mm)	18' 6" (5639 mm)	16' 2" (4928 mm)

Span calculations based on stud properties. Use 20-gauge (33 mils) J track.

\*Based on Model Building Code interpretation (ICBO ER-2541) for use in corridor, ceilings and stair soffits.

## Maximum Section Properties

Based on AISI Specifications for the Design of Cold-Formed Steel Structural Members.

C-T Stud Size	T	W	A	I <sub>x</sub>	S <sub>x</sub> (C)	S <sub>x</sub> (T)
2-1/2" (64 mm) – 25 gauge (18 mils)	0.0179	0.470	0.118	0.132	0.095	0.118
2-1/2" (64 mm) – 20 gauge (33 mils)	0.0329	0.820	0.218	0.242	0.175	0.217
4" (102 mm) – 25 gauge (18 mils)	0.0179	0.580	0.145	0.374	0.171	0.207
4" (102 mm) – 20 gauge (33 mils)	0.0329	1.020	0.267	0.687	0.341	0.380
6" (152 mm) – 25 gauge (18 mils)	0.0179	0.715	0.181	0.957	0.299	0.347
6" (152 mm) – 20 gauge (33 mils)	0.0329	1.260	0.333	1.759	0.543	0.637

T = Minimum Uncoated Base Steel Thickness (inches)  
W = Weight (pounds per linear foot)

A = Sectional Area (inches)  
I<sub>x</sub> = Moment of Inertia (inches)

S<sub>x</sub>(C) = Section Modulus 'C' flange (inches)  
S<sub>x</sub>(T) = Section Modulus 'T' flange (inches)

## Limiting Heights for 1-, 2- and 3-Hour Systems

C-T Stud Depth	Stud & Track Gauge	Design Deflection Limit	Uniform Load (PSF)							
			For 1-hr.				For 2- to 3-hr.			
			5	7.5	10	15	5	7.5	10	15
2.5" (64 mm)	25 (18 mils)	L/120	14' 2" (4318 mm)	12' 5" (3785 mm)	11' 3" (3429 mm)	9' 4" (2845 mm)	15' 6" (4724 mm)	13' 3" (4037 mm)	11' 6" (3505 mm)	9' 5" (2870 mm)
		L/180	12' 5" (3785 mm)	10' 10" (3302 mm)	9' 10" (2997 mm)	8' 7" (2616 mm)	13' 7" (4140 mm)	11' 10" (3607 mm)	10' 9" (3277 mm)	9' 5" (2870 mm)
		L/240	11' 3" (3429 mm)	9' 10" (2997 mm)	8' 11" (2718 mm)	7' 10" (2388 mm)	12' 4" (3759 mm)	10' 9" (3277 mm)	9' 9" (2972 mm)	8' 6" (2591 mm)
		L/360	9' 10" (2997 mm)	8' 7" (2616 mm)	7' 10" (2388 mm)	6' 10" (2083 mm)	10' 9" (3277 mm)	9' 5" (2870 mm)	8' 6" (2591 mm)	7' 6" (2286 mm)
2.5" (64 mm)	20 (33 mils)	L/120	15' 10" (4826 mm)	13' 10" (4216 mm)	12' 6" (3810 mm)	10' 11" (3327 mm)	17' 4" (5283 mm)	15' 1" (4597 mm)	13' 9" (4191 mm)	12' 0" (3658 mm)
		L/180	13' 10" (4216 mm)	12' 1" (3683 mm)	10' 11" (3327 mm)	9' 7" (2921 mm)	15' 1" (4597 mm)	13' 2" (4013 mm)	12' 0" (3658 mm)	10' 6" (3200 mm)
		L/240	12' 6" (3810 mm)	10' 11" (3327 mm)	9' 11" (3027 mm)	8' 8" (2642 mm)	13' 9" (4191 mm)	12' 0" (3658 mm)	10' 11" (3327 mm)	9' 6" (2896 mm)
		L/360	10' 11" (3327 mm)	9' 7" (2921 mm)	8' 8" (2642 mm)	7' 7" (2311 mm)	12' 0" (3658 mm)	10' 6" (3200 mm)	9' 6" (2896 mm)	8' 4" (2540 mm)
4" (102 mm)	25 (18 mils)	L/120	19' 1" (5817 mm)	15' 11" (4851 mm)	13' 10" (4216 mm)	11' 3" (3429 mm)	19' 7" (5969 mm)	15' 11" (4851 mm)	13' 10" (4216 mm)	11' 3" (3429 mm)
		L/180	16' 8" (5080 mm)	14' 6" (4470 mm)	13' 2" (4013 mm)	11' 3" (3429 mm)	18' 3" (5563 mm)	15' 11" (4851 mm)	13' 10" (4216 mm)	11' 3" (3429 mm)
		L/240	15' 1" (4597 mm)	13' 2" (4013 mm)	12' 0" (3658 mm)	10' 6" (3200 mm)	16' 7" (5055 mm)	14' 5" (4394 mm)	13' 2" (4013 mm)	11' 3" (3429 mm)
		L/360	13' 2" (4013 mm)	11' 6" (3505 mm)	10' 6" (3200 mm)	9' 2" (2794 mm)	14' 5" (4394 mm)	12' 8" (3861 mm)	11' 6" (3505 mm)	11' 3" (3429 mm)
4" (102 mm)	20 (33 mils)	L/120	21' 8" (6604 mm)	18' 11" (5766 mm)	17' 2" (5232 mm)	15' 0" (4572 mm)	23' 8" (7214 mm)	20' 8" (6299 mm)	18' 9" (5715 mm)	15' 6" (4724 mm)
		L/180	18' 11" (5766 mm)	16' 6" (5029 mm)	15' 0" (4572 mm)	13' 1" (3988 mm)	20' 8" (6299 mm)	18' 1" (5518 mm)	16' 5" (5004 mm)	14' 4" (4369 mm)
		L/240	17' 2" (5232 mm)	15' 0" (4572 mm)	13' 8" (4166 mm)	11' 11" (3632 mm)	18' 9" (5715 mm)	16' 5" (5004 mm)	14' 11" (4547 mm)	13' 0" (3962 mm)
		L/360	15' 0" (4572 mm)	13' 1" (3988 mm)	11' 11" (3632 mm)	10' 5" (3175 mm)	16' 5" (5004 mm)	14' 4" (4369 mm)	13' 0" (3962 mm)	11' 5" (3480 mm)
6" (152 mm)	25 (18 mils)	L/120	22' 7" (6883 mm)	18' 9" (5715 mm)	16' 3" (4953 mm)	12' 0" (3658 mm)	22' 11" (6985 mm)	18' 9" (5715 mm)	16' 3" (4953 mm)	12' 0" (3658 mm)
		L/180	19' 9" (6020 mm)	17' 3" (5258 mm)	15' 8" (4775 mm)	12' 0" (3658 mm)	21' 8" (6604 mm)	18' 9" (5715 mm)	16' 3" (4953 mm)	12' 0" (3658 mm)
		L/240	17' 11" (5461 mm)	15' 8" (4775 mm)	14' 3" (4343 mm)	12' 0" (3658 mm)	19' 8" (5994 mm)	17' 2" (5232 mm)	15' 7" (4750 mm)	12' 0" (3658 mm)
		L/360	15' 8" (4775 mm)	13' 8" (4166 mm)	12' 5" (3785 mm)	10' 10" (3302 mm)	17' 2" (5232 mm)	15' 0" (4572 mm)	13' 8" (4166 mm)	11' 11" (3632 mm)
6" (152 mm)	20 (33 mils)	L/120	27' 4" (8331 mm)	23' 11" (6985 mm)	21' 8" (6604 mm)	19' 0" (5791 mm)	30' 0" (9144 mm)	26' 2" (7976 mm)	23' 7" (7188 mm)	19' 3" (5867 mm)
		L/180	23' 11" (6985 mm)	21' 11" (6680 mm)	19' 0" (5791 mm)	16' 7" (5055 mm)	26' 2" (7976 mm)	22' 11" (6985 mm)	20' 9" (6325 mm)	18' 2" (5537 mm)
		L/240	21' 8" (6604 mm)	19' 0" (5791 mm)	17' 3" (5258 mm)	15' 1" (4597 mm)	23' 9" (7239 mm)	20' 9" (6325 mm)	18' 11" (5766 mm)	16' 6" (5029 mm)
		L/360	19' 0" (5791 mm)	16' 7" (5055 mm)	15' 1" (4597 mm)	13' 2" (4013 mm)	20' 9" (6325 mm)	18' 2" (5537 mm)	16' 6" (5029 mm)	14' 5" (4394 mm)

## Sound Chart

Fire Rated Assembly No.	Stud Size	Insulation Thickness	Resilient Channel	STC	Sound Report No.
UL V473 - 1 hr./WHI GP/WA 60/01	2-1/2"	1-1/2"	No	43	RAL TL09-357
UL V473 - 1 hr./WHI GP/WA 60/01	2-1/2"	1-1/2"	Yes	48	RAL TL09-363
UL V473 - 1 hr./WHI GP/WA 60/01	4"	2-1/2"	No	47	RAL TL10-22
UL V473 - 1 hr./WHI GP/WA 60/01	4"	2-1/2"	Yes	52	RAL TL10-27
UL 473 - 2 hr.	2-1/2"	1-1/2"	No	51	RAL TL09-358
UL 473 - 2 hr.	2-1/2"	1-1/2"	Yes	54	RAL TL09-364
UL 473 - 2 hr.	4"	2-1/2"	No	52	RAL TL10-21
UL 473 - 2 hr.	4"	2-1/2"	Yes	56	RAL TL10-28
WHI GP/WA 120-01	2-1/2"	1-1/2"	No	50	RAL TL09-360
WHI GP/WA 120-01	2-1/2"	1-1/2"	Yes	52	RAL TL09-362
WHI GP/WA 120-01	4"	2-1/2"	No	52	RAL TL10-24
WHI GP/WA 120-01	4"	2-1/2"	Yes	56	RAL TL10-26
WHI GP/WA 120-02	2-1/2"	1-1/2"	No	46	RAL TL09-359
WHI GP/WA 120-02	2-1/2"	1-1/2"	Yes	51	RAL TL09-361
WHI GP/WA 120-02	4"	2-1/2"	No	52	RAL TL10-23
WHI GP/WA 120-02	4"	2-1/2"	Yes	55	RAL TL10-25

## Door Frame Details

There are numerous elevator door frame combinations and special conditions that cannot be detailed beyond general conditions in this catalog. The interface of the shaftwall system and elevator door frame should be addressed in the shop drawings of the elevator and/or frame manufacturer literature.

- A. C-T, C-H or I studs 24" (610 mm) o.c.
- B. Pan head screws on both sides of door framing
- C. J track - 20 (33 mils) or 25 gauge (18 mils), as required
- D. Intersection Detail
- E. Gypsum board filler strips may be required where jambs are in place prior to walls to allow proper fastening of gypsum board J-track
- F. 20-gauge (33 mils) J track
- G. 20-gauge (33 mils) J track screwed to jamb anchor clips
- H. Solid gypsum board filler strips as required for frames
- I. 1" (25.4 mm) DensGlass® Shaftliner panel
- J. 1/2" (12.7 mm) DensArmor Plus® Fireguard C® interior panel or 1/2" (12.7 mm) ToughRock® Fireguard C® gypsum board
- K. Acoustical Sealant
- L. Power actuated fasteners 24" (610 mm) o.c.

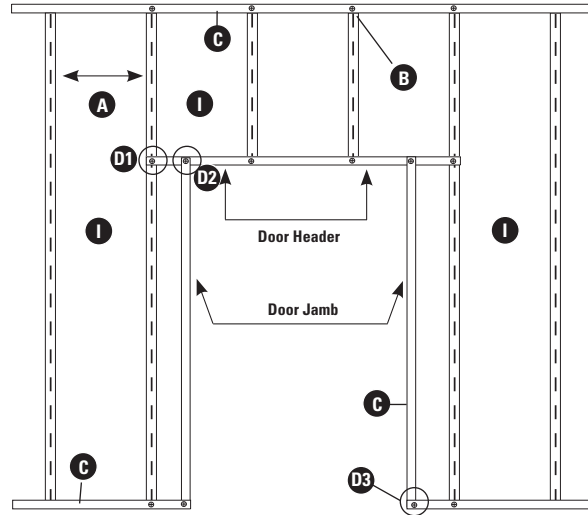

### Door Header

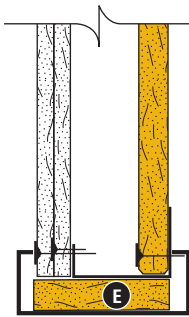

### Door Jamb, Typical

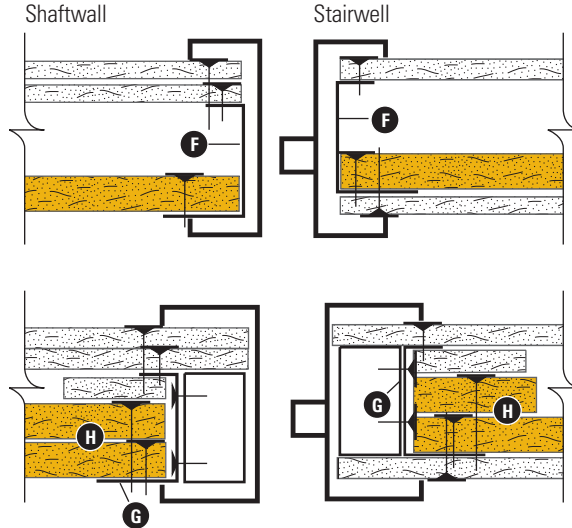

### Intersection Details

Detail 1 (D1)

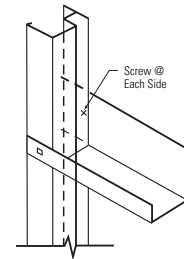

Detail 2 (D2)

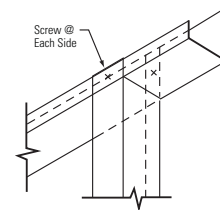

Detail 3 (D3)

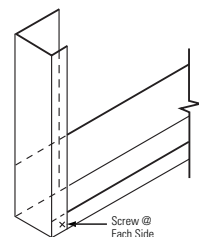

### View of Top of Wall

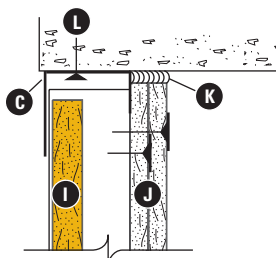

### View of Base

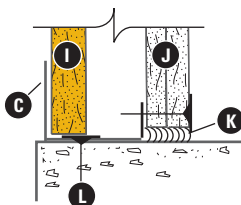

## Wall Frame Details

- A. Alternate to bending tabs: use 1-5/8" (41 mm) Type S screws at 24" (610 mm) o.c.
- B. Tabs in J track bent out at 24" (610 mm), alternate to using screws
- C. J track - 20 (33 mils) or 25 (18 mils) gauge
- D. Attached to J track prior to installation.
- E. Metal C stud or J track where span is over 24" (610 mm), alternate to using screws
- F. Spray-on fireproofing
- G. 1/2" (12.7 mm) DensArmor Plus® Fireguard C® or 1/2" (12.7 mm) ToughRock® Fireguard C® gypsum board
- H. 1" (25.4 mm) DensGlass® Shaftliner panel
- I. Acoustical Sealant
- J. Control joint
- K. Corner bead
- L. Column

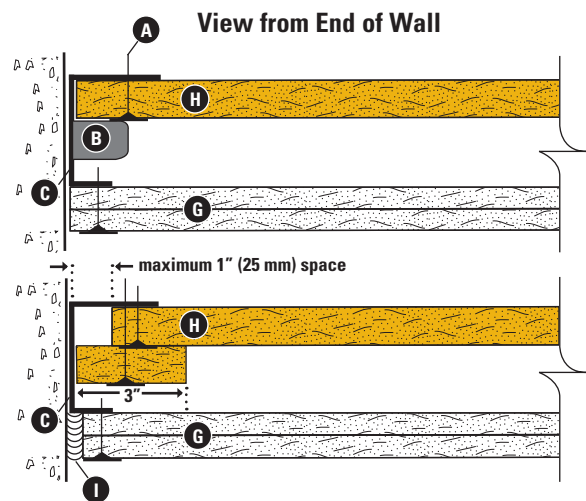
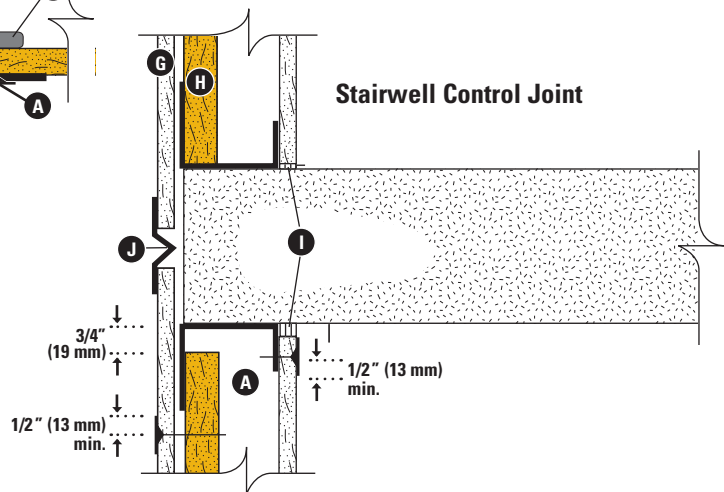
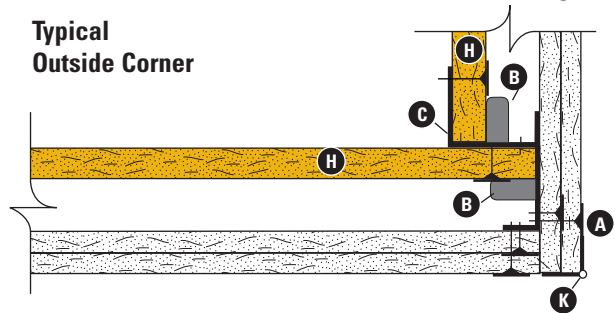
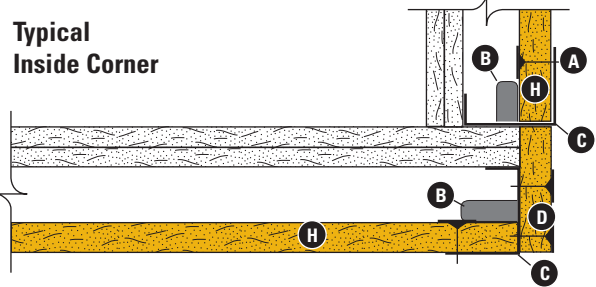
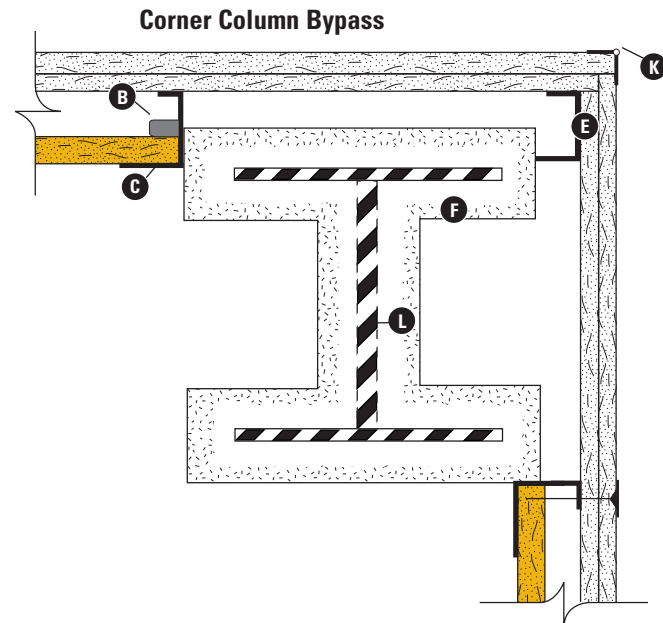
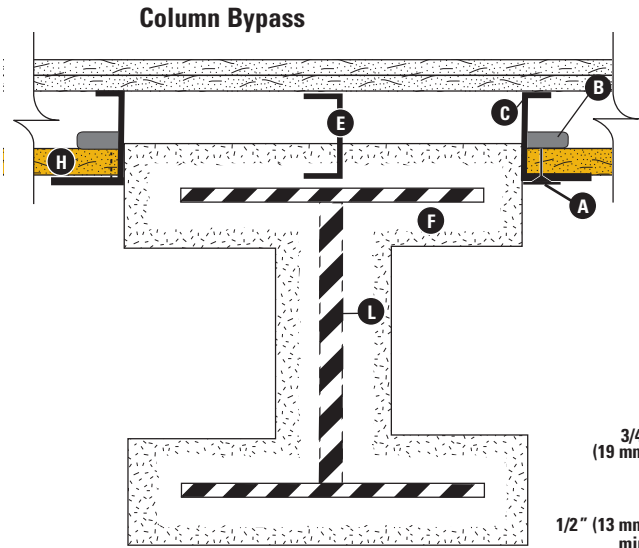

## Rails/Chute/Beam Details

- A. 1" (25.4 mm) DensGlass® Shaftliner panel
- B. Additional attachment of 1" (25.4 mm) DensGlass Shaftliner panel, inside or outside item A
- C. 1/2" (12.7 mm) DensArmor Plus® Fireguard C® or 1/2" (12.7 mm) ToughRock® Fireguard C® gypsum board
- D. Typical call indicator box
- E. Spray-on fireproofing
- F. Fasteners 24" (610 mm) o.c.
- G. J track
- H. Handrail
- I. 6" (152 mm) wide 16-gauge (54 mils) steel backing plate screwed to C-T Studs

### Call Box/Outlet Box/Mail Chute

4" (102 mm) minimum height behind box and screw attached to tabs or flanges of C-T studs or J track.

Attachment needed either inside or outside shaft cavity. Top layer optional.

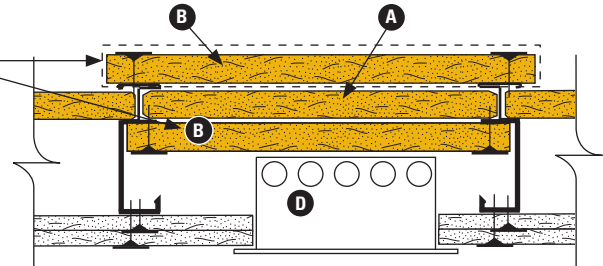

### Steel Beam

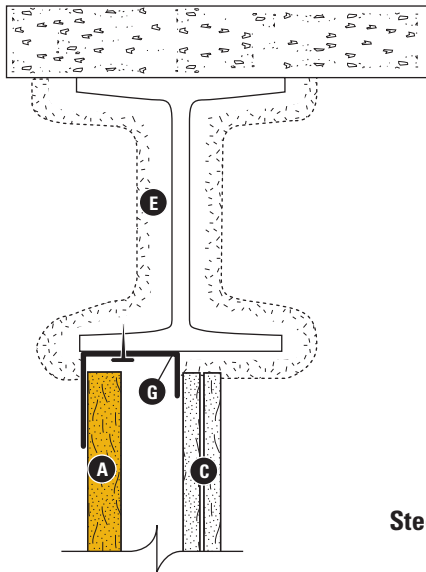

### Heavy-Duty Handrail

Backing for attachment of a wide variety of items in commercial and industrial usage, typically uses 16-gauge (54 mils) steel strips attached to the framing. Special loads should be given particular attention.

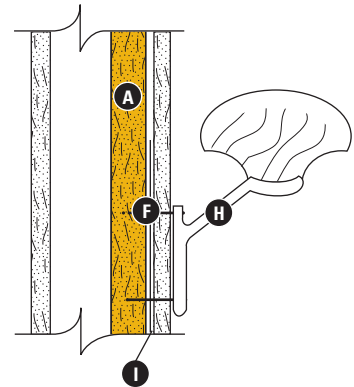

### Steel Beam Offset

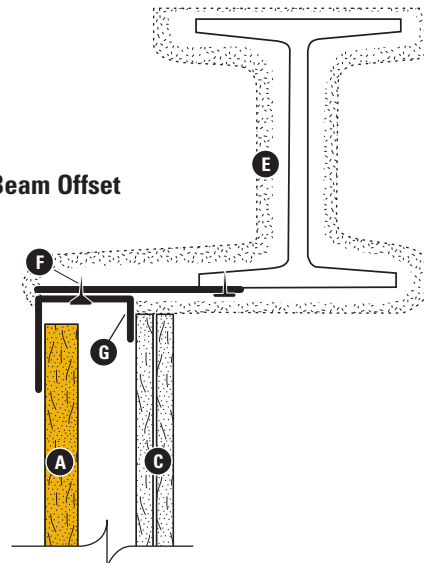



## HVAC Duct Detail

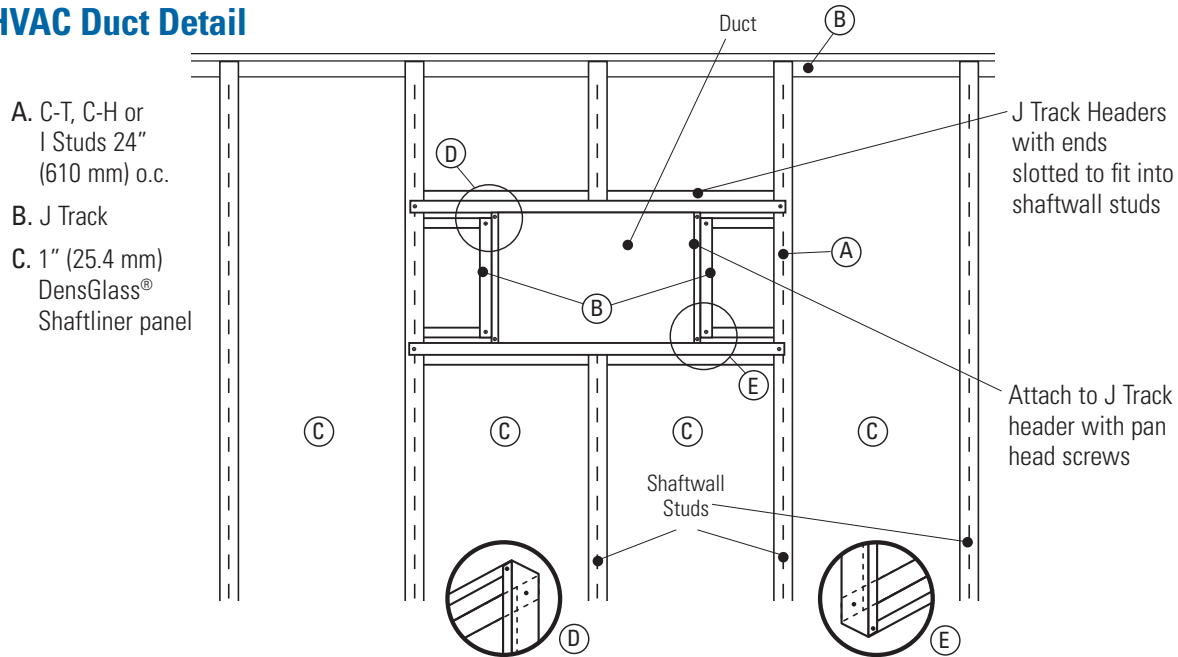

## Delivery, Handling and Storage

All materials shall be delivered in original bundles bearing the brand name, if any; applicable standard designation; and name of the manufacturer or supplier for whom the product is manufactured. The plastic packaging used to wrap gypsum panel products for rail and/or truck shipment is intended to provide temporary protection from moisture exposure during transit only and is not intended to provide protection during storage after delivery. Such plastic packaging shall be removed immediately upon receipt of the shipment. **WARNING:** Failure to remove protective plastic shipping covers can result in condensation which can lead to damage, including mold.

All materials should be kept dry. Gypsum panel products shall be neatly stacked flat with care taken to prevent sagging or damage to edges, ends and surfaces. Gypsum panel products and accessories shall be properly supported on risers on a level platform, and fully protected from weather, direct sunlight exposure, and condensation. Gypsum panel products shall be stacked flat rather than on edge or end. **WARNING:** Gypsum panel products stacked on edge or end can be unstable and present a serious hazard in the workplace should they accidentally topple.

Refer to Handling Gypsum Panel Products, GA-801, for proper storage and handling requirements.

*Reference: Application and Finishing of Gypsum Panel Products, GA-216, Gypsum Association.*

## Recommendations and Limitations for Use

The following limitations together with the installation, handling, storage and other guidelines and recommendations contained in this guide are important to ensure the proper use and benefits of DensGlass® Shaftliner. Failure to strictly adhere to such recommendations and limitations may void the limited warranty provided by Georgia-Pacific Gypsum for such product. For additional details, please go to [www.gpgypsum.com](http://www.gpgypsum.com) and select DensGlass Shaftliner for warranty information.

- Non-load-bearing.
- Can be used as exhaust ducts where temperatures do not exceed 125°F (52°C).
- Not to be used as an unlined air supply duct.
- Not designed for exposure to constant high-moisture conditions or direct water after building is complete.
- Elevator door assemblies require support independent of shaftwall partitions.
- Good construction practice calls for partition control joints to coincide with that of the building structure.
- Limiting loads and heights not to exceed design specification or data provided herein or by metal component supplier.
- Provide flexible sealant/caulk at partition perimeters and penetrations to avoid air leakage/whistling and dust collection.

## High-Performance Gypsum Products from Georgia-Pacific

<b>DensDeck® Roof Board</b>	Fiberglass mat roof board used as the ideal thermal barrier and cover board to improve resistance to wind uplift, hail, foot traffic, fire and mold in a broad range of commercial roofing applications. Look for DensDeck Prime and DensDeck DuraGuard Roof Boards, too.
<b>DensGlass® Sheathing</b>	The original and universal standard of exterior gypsum sheathing offers superior weather resistance, with a 12-month weather exposure limited warranty. Look for the familiar GOLD color. GREENGUARD listed for microbial resistance.
<b>DensGlass® Shaftliner</b>	These specially-designed panels are perfect for moisture-prone vertical or horizontal shafts, interior stairwells and area separation wall assemblies. 12-month weather exposure limited warranty. GREENGUARD listed for microbial resistance.
<b>DensArmor Plus® Interior Panel</b>	High-performance interior panel accelerates scheduling because it can be installed before the building is dried-in. 12-month weather exposure limited warranty. GREENGUARD and GREENGUARD Gold certified for low VOC emissions. Listed in CHPS® High Performance Product Database as a low emitting product. GREENGUARD listed for microbial resistance.
<b>DensArmor Plus® Abuse-Resistant Interior Panel</b>	With the same benefits as the DensArmor Plus® Interior Panel, these also offer added resistance to scuffs, abrasions and surface indentations; ideal for healthcare facilities and schools. GREENGUARD and GREENGUARD Gold certified for low VOC emissions. Listed in CHPS® High Performance Product Database as a low emitting product. GREENGUARD listed for microbial resistance.
<b>DensArmor Plus® Impact-Resistant Interior Panel</b>	With even greater durability than abuse-resistant panels, these have an embedded impact-resistant mesh for the ultimate resistance in high traffic areas; ideal for healthcare facilities, schools and correctional institutions. GREENGUARD and GREENGUARD Gold certified for low VOC emissions. Listed in CHPS® High Performance Product Database as a low emitting product. GREENGUARD listed for microbial resistance.
<b>DensShield® Tile Backer</b>	Acrylic-coated tile backer stops moisture at the surface. Lightweight and strong, they are built for speed on the job site. Conforms to requirements of 2012 IBC/IRC Code. GREENGUARD listed for microbial resistance.
<b>ToughRock® Gypsum Board</b>	Paper-faced line of gypsum panels for a variety of applications including interior wall and ceiling applications, abuse-resistant boards, and panels for use in fire-rated assemblies. ToughRock products are GREENGUARD and GREENGUARD Gold certified for low VOC emissions. Listed in CHPS® High Performance Product Database as a low emitting product.
<b>ToughRock® Mold-Guard™ Gypsum Board</b>	ToughRock Mold-Guard Gypsum Board products have enhanced mold resistance in comparison to regular ToughRock® Gypsum Boards. They are GREENGUARD and GREENGUARD Gold Certified for low VOC emissions and are listed in the CHPS® High Performance Product Database as a low emitting product. The ToughRock Mold-Guard Gypsum Board is also listed as GREENGUARD microbial resistant.



### Georgia-Pacific Gypsum

U.S.A. Georgia-Pacific Gypsum LLC  
Georgia-Pacific Gypsum II LLC  
CANADA Georgia-Pacific Canada LP

#### SALES INFORMATION AND ORDER PLACEMENT

U.S.A. West: **1-800-824-7503**  
Midwest: **1-800-876-4746**  
South Central: **1-800-231-6060**  
Southeast: **1-800-327-2344**  
Northeast: **1-800-947-4497**

CANADA Canada Toll Free: **1-800-387-6823**  
Quebec Toll Free: **1-800-361-0486**

#### TECHNICAL HOTLINE

U.S.A. and Canada: **1-800-225-6119**



#### TRADEMARKS –

Unless otherwise noted, all trademarks are owned by or licensed to Georgia-Pacific Gypsum LLC. LEED, USGBC and related logo are trademarks owned by the U.S. Green Building Council and are used by permission. Collaborative for High Performance Schools and CHPS are trademarks owned by Collaborative for High Performance Schools Inc. MICROSOFT is a registered trademark of Microsoft Corporation. MASTERSPEC is a registered trademark of The American Institute of Architects. REVIT is a registered trademark of Autodesk, Inc.

#### =WARRANTIES, REMEDIES AND TERMS OF SALE –

For current warranty information, please go to [www.gpgypsum.com](http://www.gpgypsum.com) and select the applicable product. All sales by Georgia-Pacific are subject to our Terms of Sale available at [www.gpgypsum.com](http://www.gpgypsum.com).

#### UPDATES AND CURRENT INFORMATION –

The information in this document may change without notice. Visit our website at [www.gpgypsum.com](http://www.gpgypsum.com) for updates and current information.

**CAUTION: For product fire, safety and use information, go to [buildgpc.com/safetyinfo](http://buildgpc.com/safetyinfo) or call 1-800-225-6119.**

#### HANDLING AND USE –

**CAUTION** This product contains fiberglass facings which may cause skin irritation. Dust and fibers produced during the handling and installation of the product may cause skin, eye and respiratory tract irritation. Avoid breathing dust and minimize contact with skin and eyes. Wear long sleeve shirts, long pants and eye protection. Always maintain adequate ventilation. Use a dust mask or NIOSH/MSHA approved respirator as appropriate in dusty or poorly ventilated areas.

#### FIRE SAFETY CAUTION –

Passing a fire test in a controlled laboratory setting and/or certifying or labeling a product as having a one-hour, two-hour, or any other fire resistance or protection rating and, therefore, as acceptable for use in certain fire rated assemblies/systems, does not mean that either a particular assembly/system incorporating the product, or any given piece of the product itself, will necessarily provide one-hour fire resistance, two-hour fire resistance, or any other specified fire resistance or protection in an actual fire. In the event of an actual fire, you should immediately take any and all actions necessary for your safety and the safety of others without regard for any fire rating of any product or assembly/system.

[www.gpgypsum.com](http://www.gpgypsum.com)