

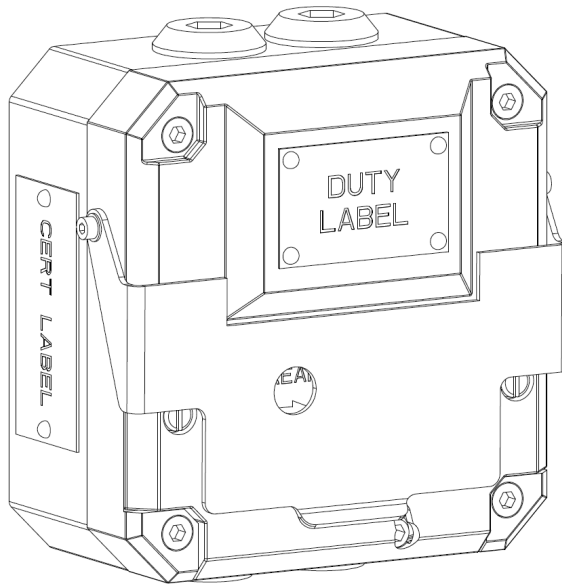

Technical Manual for the Manual Alarm Call Point – BG



Please note that every care has been taken to ensure the accuracy of our technical manual. We do not, however, accept responsibility for damage, loss or expense resulting from any error or omission. We reserve the right to make alterations in line with technical advances and industry standards.

1. INTRODUCTION

These fire alarm call point units have been designed for use in harsh environmental conditions.

2. INSTALLATION

General

When installing and operating explosion-protected electrical equipment, requirements for selection, installation and operation should be referred to eg. IEC 60079-14 worldwide and the 'National Electrical Code' in North America. Additional national and/or local requirements may apply.

Ensure that all nuts, bolts and fixings are secure.

Ensure that only the correct UL listed stopping plugs are used to blank off unused gland entry points and that the NEMA/IP rating of the unit is maintained.

The BG is mounted via 4 x Ø 0.24" (6mm) fixing holes in the base. The cover assembly must be removed to gain access to the fixing holes.

The fixing holes have been designed to accept an M5 caphead screw or bolt. MEDC recommend the use of stainless steel screws.

Cable Termination

Unscrew the 4 off screws holding the cover assembly to the base and pull away from the base. Remove to gain access to the interior of the base.

Cable termination should be in accordance with specifications applying to the application. MEDC recommend that all cables and cores should be fully identified.

Ensure that only correct UL Listed cable glands are used and that the assembly is shrouded and correctly earthed.

All cable glands should be of an equivalent NEMA/IP rating to that of the call point and integrated with the unit such that this rating is maintained.

The internal earth terminal (where fitted), must be used for the equipment grounding connection and the external terminal is for a supplementary bonding connection where local codes or authorities permit or require such a connection.

Once termination is complete, carefully push the cover assembly back onto the base, avoiding damage to the mating surfaces. Tighten the 4 off screws in the cover assembly evenly. To maintain the IP rating of the unit, the recommended torque on the cover screws is between 22.5 - 26.5 lbf-in (2.5 - 3.0Nm).

WARNING: EXPLOSION HAZARD – Do not disconnect equipment unless power has been removed or the area is known to be non-hazardous

WARNING: EXPLOSION HAZARD – Substitution of any component may impair suitability for Class 1, Division 2

AVERTISSEMENT: RISQUE D'EXPLOSION – Ne pas débrancher l'équipement à moins que l'alimentation ait été coupée ou que la zone soit connue comme étant non dangereuse.

AVERTISSEMENT: RISQUE D'EXPLOSION – La substitution d'un quelconque composant peut affecter la conformité selon la classe 1, division 2.

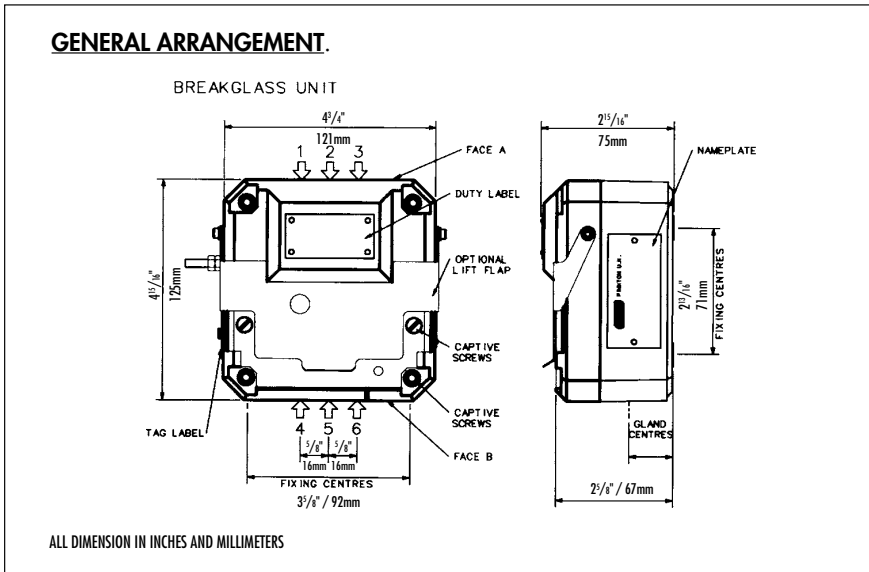

3. OPERATION

The call point is operated by breaking the glass. Due to the design of the unit, there is no need to use a hammer as the operator is protected from the broken glass by a transparent vinyl sheet.

The glass, once used, must be replaced for subsequent operations. Remove the small cover held in place by the 2 off slotted screws. Take out the glass carefully and discard. Remember to check for loose fragments. Place a new glass into the unit and replace the cover.

Testing the unit can be performed by inserting the test key provided into the hole situated on the bottom-right hand side of the glass cover. Engage the key into the test cam and turn in a clockwise direction (60° approx.). This will simulate the glass breaking. Return the key to it's initial position to reset.

MEDC does not recommend forcing the test key further than 80° clockwise or 0° anti-clockwise as this may lead to premature failure of the test cam.

4. MAINTENANCE

During the working life of the call point, little or no maintenance is required. However, if abnormal or unusual environmental conditions occur due to plant damage or accident etc., then visual inspection is recommended.

If a fault should occur, it is recommended that the unit be returned to MEDC for repair. All parts are replaceable.

If you have acquired a significant quantity of units, it is recommended that spares are also made available. Please discuss your requirements with the Technical Sales Engineers at MEDC.

5. CERTIFICATION/APPROVALS

Please refer to marking on the unit for specific approval details.

- UL listed for use in Class I, Division 2, Groups A, B, C & D.
USA (USL) and Canada (CNL)
- Standards UL38. UL50. ANSI/ISA 12.12.01. CSA-C22.2 No.14.
- Suitable for hazardous location fire-alarm applications.

6. CERTIFIED TEMPERATURE

-25°C to +55°C
-13°F to +131°F

7. Functional Safety

Introduction

The BG Call Point has been designed for use in potentially explosive atmospheres and harsh environmental conditions. The glass reinforced polyester enclosures are suitable for use offshore or onshore, where light weight combined with corrosion resistance is required.

The function of the BG is to raise an alarm manually once verification of a fire or emergency condition exists, by breaking the Glass.

The BG Break glass Unit is configured with either a single series Resistor (R1) or an R1 and end of line resistor known as R2. No Current passes through R1 in either configuration until the glass has been broken and the switch contacts have closed. Upon closure of the switch the current is then sent through R1 and hence changes the resistive value in the circuit which triggers the alarm. The R2 resistor always has a current flowing through which provides the reference resistive value for the circuit. The circuit can diagnose an open circuit failure in R1 without having to trigger the system via a continuity check which is a form of diagnostics for determining if an R1 resistor has failed Open Circuit. This form of diagnostics does however require a proof test to be conducted in order to identify the failure and depending on the set up of the system the defective Resistor may not be easily traceable if there are several BG break glass Units in the system. The end of line resistor R2 is used for the purpose of detecting an open or short circuit in the supply conductors.

The safety function of the Call Point is to raise the alarm when the Glass is Broken

Under No fault (Normal) Operating conditions the BG Break Glass Unit will raise the alarm upon operating the switch via breaking the glass.

Under fault conditions the failure mode of the Break Glass is a failure to raise the alarm. For the failure rate associated with this failure mode please refer to the table below.

Assessment of Functional Safety

The BG Call Point is intended for use in a safety system conforming to the requirements of IEC61508.

Sira Test & certification Ltd has conducted a Failure Modes Effect and Diagnostic Analysis (FMEDA) of the BG Break Glass unit against the requirements of IEC61508-2 using a proof test interval of 8760hrs.

The Call Point is classed as a Type A device.

BGI BREAKGLASS UNIT			
Safety Function of BG Break Glass Unit: <i>'To raise the alarm upon breaking the glass'</i>			
Architectural constraints:	Type A HFT=0 SFF= 97%	Proof Test Interval =8760Hrs MTTR = 8 Hrs	SIL3
Random hardware failures:	$\lambda_{DD} = 0$ $\lambda_{DU} = 5.72E-07$	$\lambda_{SD} = 0$ $\lambda_{SU} = 2.04E-05$	
Probability of failure on demand:	PFD _{AVG} =2.51E-03 (Low Demand Mode)		SIL2
Probability of Dangerous failure on safety function:	PFH = 5.72E-07 (High Demand Mode)		SIL2
Hardware safety integrity compliance ^[1]		Route 1 _H	
Systematic safety integrity compliance		Route 1 _S	
Systematic Capability		SC2	
Overall SIL-capability achieved		SIL 2 (Low Demand) SIL 2 (High Demand)	

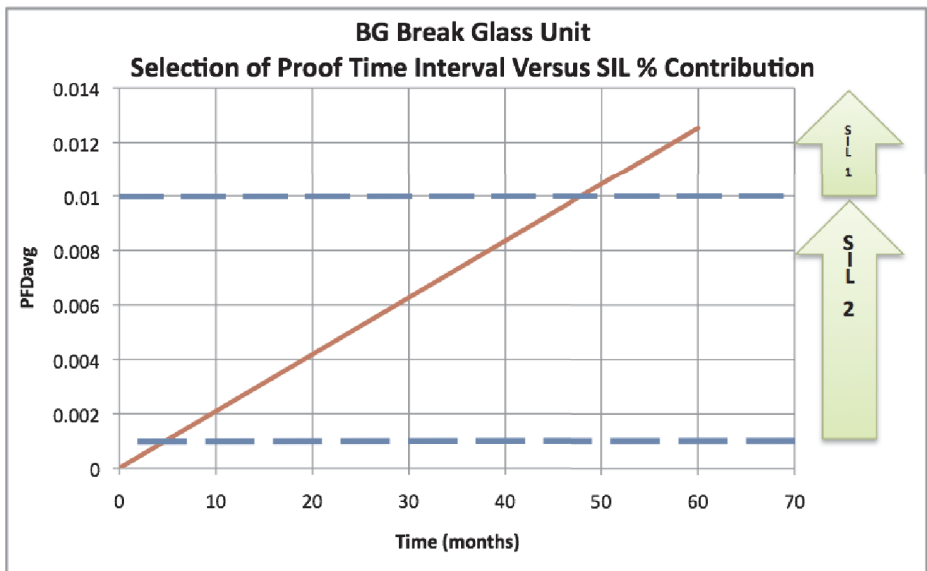

Conditions of Safe use

The following conditions apply to the installation, operation and maintenance of the assessed equipment. Failure to observe these may compromise the safety integrity of the assessed equipment:

1. The user shall comply with the requirements given in the manufacturer's user documentation (This Safety Manual and Technical manual) in regard to all relevant functional safety aspects such as application of use, installation, operation, maintenance, proof tests, maximum ratings, environmental conditions, repair, etc;
2. Selection of this equipment for use in safety functions and the installation, configuration, overall validation, maintenance and repair shall only be carried out by competent personnel, observing all the manufacturer's conditions and recommendations in the user documentation.
3. **All information associated with any field failures of this product should be collected under a dependability management process (e.g., IEC 60300-3-2) and reported to the manufacturer.**
4. The unit should be tested at regular intervals to identify any malfunctions; in accordance with this safety manual.

Eaton MEDC Ltd, Unit B, Sutton Parkway, Oddicroft Lane,
Sutton in Ashfield, United Kingdom NG17 5FB
Tel: +44 (0)1623 444444 Fax: +44 (0)1623 444531
Email: MEDCSales@Eaton.com MEDCOrders@Eaton.com
Web: www.medc.com

MEDC Stock No:
TM110-ISS.F