

**ARMY TM 11-5855-262-23&P-2  
AIR FORCE TO 12S10-2PVS7-12  
MARINE CORPS TM 09500A-23&P/2A  
NAVSEA SW215-AT-MAB-010**

---

**TECHNICAL MANUAL**

**UNIT AND DIRECT SUPPORT  
MAINTENANCE MANUAL INCLUDING  
REPAIR PARTS AND SPECIAL TOOLS LIST**

**NIGHT VISION GOGGLES (NVG)  
AN/PVS-7B  
(NSN 5855-01-228-0937) (EIC: IPS)  
AND  
AN/PVS-7D  
(NSN 5855-01-422-5413) (EIC: N/A)**

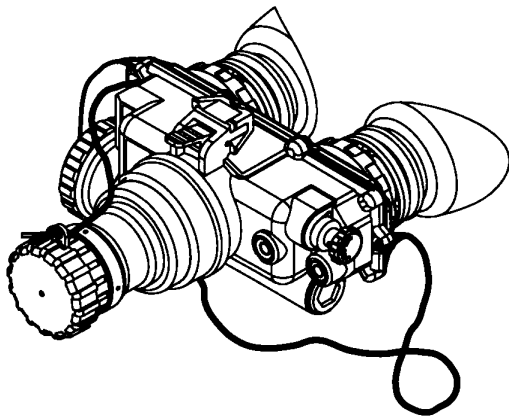

**Introduction, page 1-1**

**Equipment Description and Data, page 1-9**

**Preventive Maintenance Checks and Services, page 2-3**

**Image Intensifier Inspection Criteria, page 2-3**

**Unit Troubleshooting, page 2-3**

**Unit Maintenance Procedures, page 2-3**

**Direct Support Servicing, page 3-2**

**Direct Support Troubleshooting, page 3-3**

**Direct Support Maintenance Procedures, page 3-17**

**DISTRIBUTION STATEMENT C.** Distribution authorized to U.S. Government agencies and their contractors. This publication is required for administration and operational purposes, as determined 8 July 1991. Other requests for this document shall be referred to either: Commander, U.S. Army Communications-Electronics Command and Fort Monmouth, ATTN: AMSEL-LC-LEO-E-ED-P, Fort Monmouth, NJ 07703-5000; or Commander, Warner-Robins Air Logistics Center/LYE, 380 2nd Street, Suite 104, Robins AFB, GA 31098-1638; or Commandant of the Marine Corps (ARD), Washington, DC 20380-0001; or Commanding Officer, Naval Ship Weapons Systems Engineering Station (Code L700), Port Hueneme, CA 93043-5007.

**DESTRUCTION NOTICE** – For unclassified, limited documents, destroy by any method that will prevent disclosure of contents or reconstruction of the document.

---

**DEPARTMENTS OF THE ARMY, THE NAVY, THE  
AIR FORCE AND HEADQUARTERS, MARINE CORPS  
1 June 2000**

PCN 184 095002 00

**WARNING**

**Equipment Limitations**

To avoid physical and equipment damage when using the Night Vision Goggles (NVG), carefully read and understand the following safety precautions.

- The NVG requires some night light (moonlight, starlight, etc.) to operate. The level of performance depends upon the level of light.
- Night light is reduced by passing cloud cover, while operating under trees, in building shadows, etc.
- The NVG is less effective viewing into shadows and other darkened areas.
- The NVG is less effective through rain, fog, sleet, snow, smoke, and other reflective material.
- The NVG will not “see” through dense smoke.
- Adjust vehicular speed to prevent overdriving the range of view when conditions of possible reduction or loss of vision exist.

**WARNING**

Do not carry batteries in pockets containing metal objects such as coins, keys, etc. Metal objects can cause the batteries to short circuit and become very hot. In the case of lithium batteries, a short circuit could cause them to explode.

**WARNING**

**Danger of Explosion**

The BA-5567/U lithium battery contains sulfur dioxide gas under pressure and should be handled in the following manner:

- Do not heat, puncture, disassemble, short circuit, attempt to recharge, or otherwise tamper with the batteries.
- Turn off the equipment if the battery compartment becomes unduly hot. If possible, wait until the batteries have cooled before removing them.
- The batteries have safety vents to prevent explosion. When they are venting gas, you will smell it (very irritating) or hear the sound of gas escaping. When the safety vents have operated, the batteries are fairly safe from bursting, but will be hot and must be handled with care.
- If you inhale sulfur dioxide, seek medical attention.

**WARNING**

**Toxic Material**

The image intensifier's phosphor screen contains toxic materials.

- If an image intensifier breaks, be extremely careful to avoid inhaling the phosphor screen material. Do not allow the material to come in contact with the mouth or open wounds on the skin.
- If the phosphor screen material contacts your skin, wash it off immediately with soap and water.
- If you inhale/swallow any phosphor screen material, drink a lot of water, induce vomiting, and seek medical attention as soon as possible.

**WARNING**

Do not use any battery other than a BA-5567/U, AA alkaline, or 1.5 volt AA L91 lithium battery in the NVG. DO NOT use any battery(ies) providing a (combined) voltage greater than 3.0 volts.

**WARNING**

The IR source is a light that is invisible to the unaided eye for use during conditions of extreme darkness. However, the light from the IR source can be detected by the enemy using night vision devices. The IR spot/flood lens accessory does not reduce the ability of an enemy to detect the illuminator.

**WARNING**

The compass illuminator can be seen by other night vision users.

**WARNING**

**Personnel Injury**

- Serious injury may result if the nitrogen tank valve breaks off due to tank upset. If the tank valve breaks, the tank can be propelled by the escaping gas and strike you or others.
- Always secure the tank to an upright support before removing the tank valve guard and attaching the regulator valve to the tank.

**WARNING**

It is critical that the goggles be turned off manually before placing them in the flipped up position in order to avoid detection by the enemy.

**WARNING**

When installing the headmount over the protective mask, be careful not to break the protective mask seal around your face.

**WARNING**

Do not use contaminated eyecups. They must be replaced.

**FIRST AID**

For first aid or artificial respiration, see FM 21-11, First Aid for Soldiers.

TECHNICAL MANUAL  
No. TM 11-5855-262-23&P-2  
TECHNICAL ORDER  
No. 12S10-2PVS7-12  
TECHNICAL MANUAL  
No. 09500A-23&P/2A  
TECHNICAL MANUAL  
No. SW215-AT-MAB-010

DEPARTMENTS OF THE ARMY,  
THE AIR FORCE,  
THE NAVY, AND  
HEADQUARTERS, MARINE CORPS  
Washington, DC  
1 June 2000

**UNIT AND DIRECT SUPPORT MAINTENANCE MANUAL  
INCLUDING REPAIR PARTS AND SPECIAL TOOLS LIST**

**NIGHT VISION GOGGLES (NVG)  
AN/PVS-7B (NSN 5855-01-228-0937) (EIC: IPS)  
AND  
AN/PVS-7D (NSN 5855-01-422-5413) (EIC: N/A)**

**REPORTING ERRORS AND RECOMMENDING IMPROVEMENTS**

You can help improve this manual. If you find any mistakes or if you know of a way to improve the procedures, please let us know. Mail your letter, DA Form 2028 (Recommended Changes to Publications and Blank Forms), or DA Form 2028-2 located in the back of this manual direct to: Commander U.S. Army Communications-Electronics Command and Fort Monmouth, ATTN: AMSEL-LC-LEO-D-CS-CFO, Fort Monmouth, New Jersey 07703-5000. The Fax number is 732-532-1413, DSN 992-1413. You may also email your recommendations to [AMSEL-LC-LEO-PUBS-CHG@cecom3.monmouth.army.mil](mailto:AMSEL-LC-LEO-PUBS-CHG@cecom3.monmouth.army.mil).

For Air Force, submit AFTO Form 22 (Technical Order System Publication Improvement Report and Reply) in accordance with paragraph 6-5, Section VI, TO 00-5-1. Forward to Warner-Robins Air Logistics Center/LYGO, 380 2<sup>nd</sup> Street, Suite 104, Robins AFB, GA 31098-1638.

For Marine Corps, send NAVMC 10772 to: Commander, Marine Corps Logistics Base (Code 826), 814 Radford Blvd, Albany, GA 31704-5000.

For Navy, send NAVSEA Form 9086/10 to: Commanding Officer, Naval Ship Weapon Systems Engineering Station (Code 5H00), Port Hueneme, CA 93043-5007.

A reply will be furnished to you.

\*Supersedes TM 11-5855-262-23&P-2 dated 15 March 1993

## TABLE OF CONTENTS

<u>Paragraph</u>	<u>Title</u>	<u>Page</u>
	How to Use This Manual .....	vii
CHAPTER 1	<b>INTRODUCTION</b> .....	1-1
Section I	General Information .....	1-1
1-1	Scope .....	1-1
1-2	Maintenance Forms, Records, and Reports .....	1-2
1-3	Destruction of Electronic Materiel to Prevent Enemy Use .....	1-2
1-4	Preparation for Storage or Shipment.....	1-2
1-5	Official Nomenclature, Names, and Designations .....	1-2
1-6	Reporting Equipment Improvement Recommendations (EIR) .....	1-4
1-7	Warranty Information .....	1-4
1-8	Corrosion Prevention and Control (CPC) .....	1-8
Section II	<b>Equipment Description and Data</b> .....	1-9
1-9	Equipment Characteristics, Capabilities, and Features .....	1-9
1-10	Location and Description of Major Components .....	1-10
1-11	Configuration of Image Intensifier .....	1-15
1-12	Equipment Data .....	1-16
Section III	Principles of Operation.....	1-18
1-13	Mechanical Functions .....	1-18
1-14	Optical Functions .....	1-19
1-15	Electronic Circuit Functions.....	1-19
CHAPTER 2	UNIT MAINTENANCE INSTRUCTIONS .....	2-1
Section I	Repair Parts, Tools, Special Tools, TMDE, and Support Equipment .....	2-1
2-1	Common Tools and Equipment.....	2-1
2-2	Special Tools, TMDE, and Support Equipment .....	2-2
2-3	Repair Parts.....	2-2
Section II	Service Upon Receipt .....	2-2
2-4	Site and Shelter Requirements .....	2-2
2-5	Service Upon Receipt of Material.....	2-2
2-6	Installation.....	2-3
Section III	<b>Preventive Maintenance Checks and Services</b> .....	2-3
2-7	Preventive Maintenance Checks and Services (PMCS) Table .....	2-3
2-8	<b>Inspection Criteria for Proper Image Intensifier Operation</b> .....	2-3
Section IV	<b>Troubleshooting</b> .....	2-3
2-9	Troubleshooting .....	2-3
2-10	Resolution Check Using TS-4348/UV Test Set .....	2-3

## TABLE OF CONTENTS - Continued

<u>Paragraph</u>	<u>Title</u>	<u>Page</u>
Section V	<b>Maintenance Procedures</b> .....	2-3
2-11	Removal and Installation of Components .....	2-3
2-12	Removal and Installation of Battery Cap and Battery Cap Retainer .....	2-4
2-13	Removal and Installation of Browpads .....	2-4
2-14	Removal and Installation of Neck Pad .....	2-4
2-15	Removal and Installation of Chinstrap .....	2-6
2-16	Removal and Installation of Cross-strap .....	2-6
2-17	Removal and Installation of Power Switch Knob .....	2-8
2-18	Removal and Installation of Magnet on Metal Helmet Mount .....	2-8
2-19	Repainting and Refinishing Requirements .....	2-10
2-20	Lubrication Requirements .....	2-10
Section VI	Preparation for Storage and Shipment .....	2-10
2-21	Packing the NVG .....	2-10
CHAPTER 3	DIRECT SUPPORT MAINTENANCE INSTRUCTIONS .....	3-1
Section I	Repair Parts, Tools, Special Tools, TMDE, and Support Equipment .....	3-1
3-1	Common Tools and Equipment .....	3-1
3-2	Special Tools, TMDE, and Support Equipment .....	3-1
3-3	Repair Parts .....	3-2
Section II	Service Upon Receipt .....	3-2
3-4	Site and Shelter Requirements .....	3-2
3-5	Service Upon Receipt of Material .....	3-2
Section III	<b>Servicing</b> .....	3-2
3-6	Scope .....	3-2
Section IV	<b>Troubleshooting</b> .....	3-3
3-7	Troubleshooting .....	3-3
3-8	TS-3895A/UV Preparation for Use .....	3-6
3-9	Testing the NVG Using TS-3895A/UV .....	3-6
3-10	Electrical Troubleshooting .....	3-10
3-11	Black Spot Check .....	3-12
Section V	<b>Maintenance Procedures</b> .....	3-17
3-12	Removal and Installation of Objective Lens .....	3-17
3-13	Objective Lens Infinity Focus Adjustment .....	3-20

**TABLE OF CONTENTS - Continued**

<u>Paragraph</u>	<u>Title</u>	<u>Page</u>	<u>Figure</u>
3-14	Removal and Installation of Image Intensifier .....	3-20	
3-15	Removal and Installation of Collimator .....	3-22	
3-16	Removal and Installation of Wired Housing .....	3-26	
3-17	Removal and Installation of Rear Cover .....	3-28	
3-18	Purging .....	3-29	
3-19	Operational Checks .....	3-33	
Section VI	Preparation for Storage and Shipment .....	3-33	
3-20	Packing the NVG .....	3-33	
3-21	Shipping the Image Intensifier.....	3-33	
APPENDIX A	REFERENCES		
A-1	Scope .....	A-1	
A-2	Forms .....	A-1	
A-3	Field Manuals .....	A-1	
A-4	Technical Manuals .....	A-1	
A-5	Miscellaneous Publications .....	A-1	
A-6	Marine Corps Use .....	A-2	
A-7	Air Force Use .....	A-2	
APPENDIX B	MAINTENANCE ALLOCATION CHART (MAC) (ARMY ONLY)		
Section I	Introduction .....	B-1	
B-1	The Army Maintenance System, MAC .....	B-1	
B-2	Maintenance Functions .....	B-1	
B-3	Explanation of Columns in the MAC, Section II .....	B-2	
B-4	Explanation of Columns in Tools and Test Equipment Requirements, Section III .....	B-3	
B-5	Explanation of Columns in Remarks, Section IV .....	B-3	
Section II	Maintenance Allocation Chart for AN/PVS-7B and AN/PVS-7D ...	B-4	
Section III	Tools and Test Equipment Requirements for AN/PVS-7B and AN/PVS-7D .....	B-5	
Section IV	Remarks .....	B-6	
APPENDIX C	REPAIR PARTS AND SPECIAL TOOLS LIST		
Section I	Introduction .....	C-1	
C-1	Scope .....	C-1	
C-2	General .....	C-1	
C-3	Explanation of Columns (Sections II and III).....	C-1	
C-4	Explanation of Columns (Section IV) .....	C-4	
C-5	Special Information .....	C-5	
C-6	How to Locate Repair Parts .....	C-5	
C-7	Abbreviations .....	C-6	
Section II	Repair Parts List .....	C-8	
Group 00	Night Vision Goggles (NVG), AN/PVS-7B and AN/PVS-7D.....	C-8	C-1
Group 01	Goggle Assembly.....	C-10	C-2
Group 02	Headset Assembly .....	C-12	C-3
Section III	Special Tools List.....	C-14	
Group 10	Special Tools .....	C-14	C-4
Section IV	Cross-Reference Indexes .....	C-16	



**TABLE OF CONTENTS - Continued**

<u>Paragraph</u>	<u>Title</u>	<u>Page</u>	<u>Figure</u>
APPENDIX D	EXPENDABLE AND DURABLE ITEMS LIST		
Section I	Introduction.....	D-1	
D-1	Scope .....	D-1	
D-2	Explanation of Columns.....	D-1	
Section II	Expendable and Durable Items List .....	D-2	
APPENDIX E	ILLUSTRATED LIST OF MANUFACTURED ITEMS		
Section I	Introduction.....	E-1	
Section II	Manufactured Items Part Number Index .....	E-1	
Section III	Manufactured Items Illustrations .....	E-2	E-1
E-1	Black Spot Test Stand .....	E-2	E-1
GLOSSARY	.....	Glossary-1	
Section I	Abbreviations.....	Glossary-1	
Section II	Definitions of Unusual Terms.....	Glossary-2	
ALPHABETICAL INDEX	.....	Index-1	

## HOW TO USE THIS MANUAL

- **Usage**

You must familiarize yourself with the entire maintenance procedure before beginning the maintenance task. Read and follow all Warnings, Cautions and Notes.

- **Manual Overview**

The contents of each chapter are listed at the beginning of the chapter. This listing includes the paragraph title and page number. Additional references to the contents of this manual can be found in the index at the back of the manual. This manual also contains the Repair Parts and Special Tools List (RPSTL) in Appendix C for ordering repair parts. Appendix C gives details for using the RPSTL.

- **Special Feature**

A locator is provided on the right-hand border of the front cover. This gives the location of the information most frequently used. To find the topic UNIT TROUBLESHOOTING, open the manual to the correct page by using the black tab on the side of the manual that lines up with the topic UNIT TROUBLESHOOTING.

## CHAPTER 1 INTRODUCTION

---

	<u>Page</u>
Overview.....	1-1
Scope .....	1-1
Maintenance Forms, Records, and Reports .....	1-2
Destruction of Electronic Materiel to Prevent Enemy Use .....	1-2
Preparation for Storage or Shipment.....	1-2
Official Nomenclature, Names, and Designations .....	1-2
Reporting Equipment Improvement Recommendations (EIR) .....	1-4
Warranty Information .....	1-4
Corrosion Prevention and Control (CPC) .....	1-8
Equipment Characteristics, Capabilities, and Features .....	1-9
Location and Description of Major Components.....	1-10
Configuration of Image Intensifier .....	1-15
Equipment Data .....	1-16
Mechanical Functions .....	1-18
Optical Functions .....	1-19
Electronic Circuit Function .....	1-19

### **OVERVIEW**

Chapter 1 of this technical manual is intended to give you information regarding the type of equipment, its characteristics, and the principles of operation that will help you maintain it properly. Figure 1-2 (Sheets 1 through 4), shows the storage locations of components in the carrying cases.

### **Section I. General Information.**

#### **1-1 SCOPE**

- a. Type of Manual: Unit and Direct Support Maintenance including Repair Parts and Special Tools List (RPSTL).
- b. Model Number and Equipment Name: Night Vision Goggles (NVG), AN/PVS-7B and AN/PVS-7D.
- c. Purpose of Equipment: The NVG are self-contained night vision devices that enable improved night vision using ambient light from the night sky (moon, stars, skyglow, etc.).

## **1-2 MAINTENANCE FORMS, RECORDS, AND REPORTS**

Department of the Army forms and procedures used for equipment maintenance will be those prescribed by DA Pam 738-750, as contained in Maintenance Management Update. Refer to the latest issue of DA Pam 25-30 to determine whether there are new editions, changes or additional publications or forms pertaining to this equipment.

Marine Corps personnel refer to the on-line Marine Corps Publication Distribution System (MCPDS).

Marine Corps Ground Equipment Record Procedures. Marine Corps personnel refer to TM 4700-15/1 for disposition of forms and records required for Marine Corps equipment.

## **1-3 DESTRUCTION OF ELECTRONIC MATERIEL TO PREVENT ENEMY USE**

For procedures to destroy this equipment to prevent its use by the enemy, refer to TM 750-244-2, Procedures for Destruction of Electronic Materiel to Prevent Enemy Use (Electronics Command). **Marine users**, render the NVG inoperable by smashing, scattering or burying disassembled pieces, burning, or destroying by weapons fire.

## **1-4 PREPARATION FOR STORAGE OR SHIPMENT**

See Chapter 2, paragraph 2-21, for instruction regarding preparation for storage or shipment of the NVG and Chapter 3, paragraph 3-21 for packing and shipping the image intensifier.

## **1-5 OFFICIAL NOMENCLATURE, NAMES, AND DESIGNATIONS**

Table 1-1 provides a cross-reference of common names and official terms. Except in the Appendices, the common names will be used. The official names are used in the Appendices because they reflect the provisioning nomenclature.

**1-5 OFFICIAL NOMENCLATURE, NAMES, AND DESIGNATIONS - Continued****Table 1-1. Nomenclature Cross-Reference List.**

COMMON NAME	OFFICIAL NOMENCLATURE
3X Magnifier	Magnifier Lens Assembly
Batteries	Battery, Nonrechargeable
Battery Cap	Battery Cap Assembly
Battery Cap Retainer	Retainer, Electrical
Carrying Case	Case, Infrared Equipment
Carrying Case Strap	Strapping
Chinstrap	Strap, Helmet
Collimator	Collimator, Infrared
Compass	Compass Assembly
Cross Strap	Strapping
Demist Shields	Demist Shield Assy
Eyecup	Eyecup
Goggles	Goggle Assembly
Headmount	Headset Assembly
Helmet Mount	Mount, Viewer
Image Intensifier	Image Intensifier, Night Vision
IR Spot/Flood Lens	Lens Assembly, Focusing
LIF	Filter, Infrared Light
Medium Browpad	Browpad Assy, Medium
Neck Cord	Cord, Fibrous
Neck Pad	Neck Pad Assembly
Objective Lens	Mount Assy, Objective
Objective Lens Cap	Cap, Protective, Dust
O-Ring	Packing, Preformed
Power Switch	Switch, Knob Assembly
Purge Device	Device, Purge
Purge Screw	Screw, Machine
Rear Cover	Rear Cover Assembly
Sacrificial Window	Window, Sacrificial
Screw	Screw, Machine
Shipping and Storage Case	Case, Shipping/Storage
Side Strap	Strap, Webbing
Tethering Cord	Clip, Retaining
Thick Browpad	Browpad Assy, Thick
Thin Browpad	Browpad Assy, Thin
Washer	Washer, Flat
Wired Housing	Wired Housing Assembly

## **1-6 REPORTING EQUIPMENT IMPROVEMENT RECOMMENDATIONS (EIR)**

If your NVG needs improvement, let us know. Send us an EIR. You, the user, are the only one who can tell us what you don't like about the design. Put it on an SF 368 Product Quality Deficiency Report. Mail it to Commander, U.S. Army Communications-Electronics Command and Fort Monmouth, ATTN: AMSEL-LC-LEO-D-CS-CFO, Fort Monmouth, New Jersey 07703-5000. We will send you a reply.

MARINE CORPS PERSONNEL are encouraged to submit SF 368 in accordance with MCO 4855.10 (Quality Deficiency Report).

## **1-7 WARRANTY INFORMATION**

NVGs are warranted by the manufacturer to conform to design and manufacturing requirements, to remain free from defects in materials and workmanship, and to conform to performance specifications. The warranty expiration date is printed on a label affixed to the end item and a separate label affixed to the image intensifier. The Direct Support (DS)/Intermediate maintenance level personnel make the determination of a warranty defect. If a warranty defect is detected, the product (either the end item or the image intensifier) is returned directly to the manufacturer for warranty service in accordance with applicable service (Army, Navy, and Marine Corps) procedures. Warranty defects may consist of the following:

- Image intensifier does not light up.
- Image tube fails the low light resolution and/or high light resolution.
- Image intensifier exhibits any one, or more, of the operational defects described in "Inspection Criteria for Image Intensifier Operation" as defined in the Operator's Maintenance Manual (such as, shading, edge glow, flashing, flickering or intermittent operation).
- Fails the electrical troubleshooting test.
- Obvious mechanical malfunction with no evidence of severe trauma that indicates customer damage.

The manufacturer will use the same list of criteria in verifying a defect covered by the warranty.

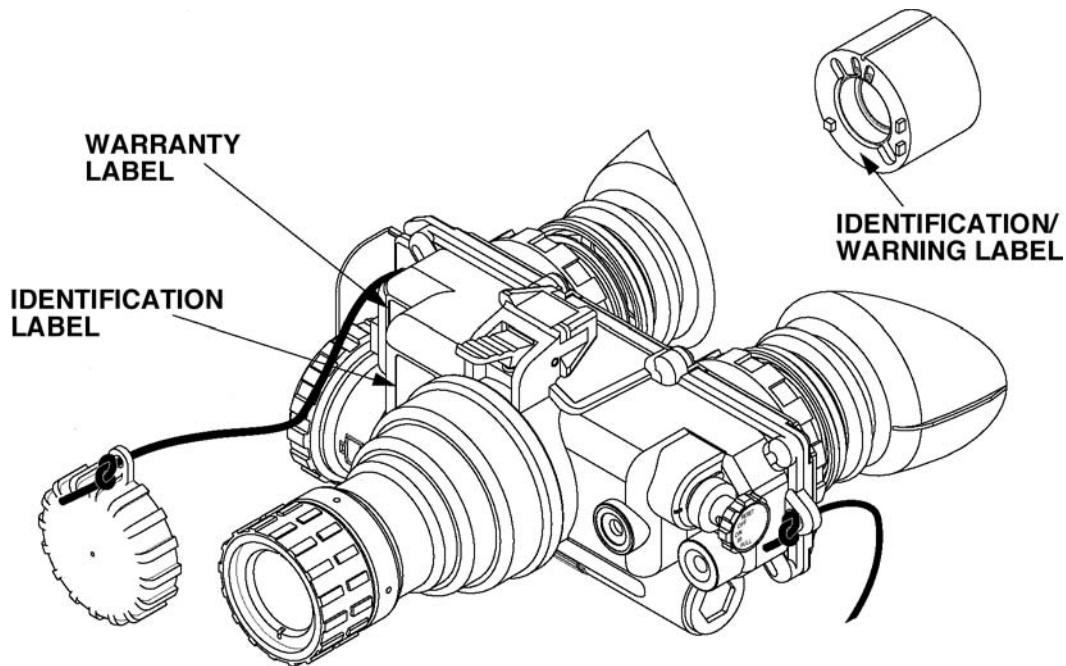
**1-7 WARRANTY INFORMATION - Continued**

**Figure 1-1. Warranty Expiration Label Location.**

**NOTE**

This warranty does not cover any product that has been subject to misuse, neglect, accident, installation or maintenance in violation of the instructions in the Operator's or Maintenance Technical Manuals. Also, a maintenance testing fee of \$100.00 per image intensifier or \$150.00 per end item will be charged to the appropriate activity for returns which are determined to have no evidence of a defect or have been subjected to misuse, neglect, etc. **Therefore, all PMCS and troubleshooting procedures must be performed before determining that the end item or image intensifier requires warranty action.**

**a. Turn-in Procedures.**

(1) The operator, after completing the PMCS and Troubleshooting, annotates the fault on DA Form 2404 (Army) or OPNAV Form 4790/138 (Navy), completes the appropriate blocks and turns the equipment into the unit maintainer. The unit maintainer will perform all applicable PMCS and Troubleshooting before determining that the end item does not show any faults or must be sent to Direct Support (DS)/Intermediate maintenance for further maintenance actions. If it is determined that the end item needs Intermediate repair, the unit maintainer will annotate DA Form 2407 (Army), OPNAV Form 4790/60 (Navy/Marine Corps), and include this form with the end item and send it to appropriate Intermediate maintenance activity. DA Pam 738-750 outlines distribution of copies.

(2) The Direct Support (DS)/Intermediate maintenance activity performs all troubleshooting and maintenance procedures in accordance with the maintenance manual. If a defect is identified and the product is under warranty, per the warranty expiration date on the label, a warranty return is initiated.

**1-7 WARRANTY INFORMATION - Continued**

**NOTE**

The NVG that fails either the service upon initial receipt of material inspection or fails prior to the expiration of the warranty must be reported on a Product Quality Deficiency Report (PQDR), SF 368. This will ensure the unit submitting the PQDR will receive credit for the NVG. DA Pam 738-750 outlines distribution of copies.

**NOTE**

If using an automated system such as SAMS or ULLS, use the equivalent electronic form, to track using the same procedure as for the hard copy DA Form 2404, 2407 or DD Form 314 etc.

**NOTE**

For units operating under SAMS, DA Form 5504 (Maintenance Request) and 5504-1 (Maintenance Request Continuation Sheet) are the only forms used to file warranty claim actions. Do not use SF 368 to report Warranty Claims. DA Pam 738-750 outlines distribution of copies.

**NAVY ONLY:** The item should be tagged (e. g. using the DD Form 1577-2). An OPNAV 4790/60, VIDS/MAF shall be filled out which will include the nature of the defect, i. e., spots, flicker, edge glow, etc. and method used to determine type and extent of defect. A product quality deficiency report, message or form SF 368, should be filed for an IN-WARRANTY item to the FST: Commander, Code 805B-Bldg 3291 NAVSURFWARCENDIV, 300 Highway 361, Crane, IN 47522-5001. No defective warranty items are to be shipped directly from the field to a contractor. If there are reoccurring problems for deficient out-of-warranty assemblies, an engineering investigation, in accordance with OPNAVINST 4790.2G, should be forwarded to the FST.

(3) Activities should follow local procedures for shipping equipment to the manufacturer. DD Form 1149 (Requisition and Invoice/Shipping Document) will accompany all shipments to the manufacturer's factory. The manufacturer will prepare a new DD Form 1149 for return shipment to the relevant activity. DA Pam 738-750 outlines distribution of copies.

**b. Return Procedures.** The manufacturer will repair and return all warranted equipment back to designated activities.

To determine the manufacturer of the item, check the identification plate for the manufacturer's (MFR) CAGEC (Commercial and Government Entity Code).

CAGEC	Manufacturer
13567 or 66868	ITT, Roanoke, VA
55311 or 51298	Litton, Tempe, AZ

**OCONUS WARRANTY PROCEDURES ARMY ONLY:**

DS/AVIM will contact one of the following POC's in lieu of contacting the manufacturer for warranty claims.

RSC, Friedrichsfeld, Germany  
POC: Mr. Mike Haase  
DSN 314-375-5348  
[mhaase@hq.amceur.army.mil](mailto:mhaase@hq.amceur.army.mil)

RSC, Korea  
POC: Mr. Harry Footit  
DSN 315-722-3571  
[footith@usfk.korea.army.mil](mailto:footith@usfk.korea.army.mil)



**1-7 WARRANTY INFORMATION - Continued**

**(1) Voice Media (Telephone).**

(a) For items manufactured by ITT (CAGEC 13567 or 66868): This is accomplished by calling ITT at 1-800-360-6054 during regular business hours 07:30 - 11:30 and 12:30 - 16:30 Eastern Standard (or Daylight Savings) Time, Monday through Friday. During non-business hours, voice mail will be operative which will direct the caller to leave name and complete commercial telephone number including appropriate area code or country/city code and a brief message. ITT will return calls within two business days. Using voice media, ITT may be able to offer on-the-spot suggestions to help solve a problem. If the problem cannot be resolved over the phone and the product is under warranty, ITT will provide the caller with a Return Authorization (RA) number and appropriate shipping instructions.

(b) For items manufactured by Litton (CAGEC 55311 or 51298): This is accomplished by calling the Litton Customer Service Representative at 1-800-569-8478 during regular business hours 07:00 – 15:30 Mountain Standard Time, Monday through Friday. The Litton Customer Service Representative can also be reached at 602-303-8956 during regular business hours. During non-business hours, voice mail is available which will direct the caller to leave a name, complete commercial telephone number, to include area code or country and city codes, and a brief message. Litton will return the call within two business days. Using voice media, Litton may be able to offer on-the-spot suggestions to solve a problem. If the problem cannot be addressed over the phone and the product is under warranty, Litton will provide the caller with a Return Goods Authorization (RGA) number and appropriate shipping instructions.

**(2) Electronic Media (E-mail).**

Because of the time zone differences, communication via E-mail may be used by any authorized customer. This procedure can be utilized 24 hours a day with E-mail access. Prepare an E-mail with the following information shown below and send it to:

Date:
Branch of Service:
UIC:
Direct Support/Intermediate Activity:
Address
Point of Contact:
Street and Number:
City:
State/Country:
Zip Code:
Commercial Telephone Number (include area code or country/city code):
Commercial FAX Number (include area code or country/city code):
E-mail Address:
Product Information:
Model:
Serial Number:
Reason for Return:

**Data Required for E-mail and FAX Communication.**

**1-7 WARRANTY INFORMATION - Continued**

(a) For items manufactured by ITT (CAGEC 13567 or 66868): Send the message to ITT at [nvwarranty@nv.de.ittind.com](mailto:nvwarranty@nv.de.ittind.com) via the internet. ITT will answer via a return message providing suggestions to help solve the problem or issue a RA number.

(b) For items manufactured by Litton (CAGEC 55311 or 51298): Send the message to Litton at [contractscs@littoneos.com](mailto:contractscs@littoneos.com) via the Internet. Litton will respond via a return message providing either a suggestion to solve a specific problem or a RGA number.

**(3) FAX Communication.**

(a) For items manufactured by ITT (CAGEC 13567 or 66868): Send a FAX with the same information as ITT requires for E-mail to ITT at FAX number (540) 366-9015.

(b) For items manufactured by Litton (CAGEC 55311 or 51298): Send a FAX with the same information, as Litton requires for E-mail to Litton at FAX number 602-966-9055. Litton will provide a response within two business days.

**c. Repair Procedures.** The manufacturer will repair and return all warranted equipment back to designated activities. An estimated cost of repair will be provided to the maintenance activity for those items that do not fall within warranty guidelines. The manufacturer will only accept written authorization from authorized personnel at DS/Intermediate maintenance activity prior to conducting repair.

**Things to do to help speed up the return of your equipment:**

1. Review your documents to make sure you have filled in all of the requested information. Your documentation must clearly explain the problem(s) you are having with the equipment.
2. Double check that your return address is legible on all of your documents, as well as, the shipping package.
3. Make sure all of the documents, except your copies, are placed inside of the package before being returned.
4. Write the RA or RGA number on the outside of your package.

**Failure to follow the above guidelines will result in a delay in the return of your equipment.**

**1-8 CORROSION PREVENTION AND CONTROL (CPC)**

Corrosion prevention and control of electronic materiel is a continuing concern. It is important that any corrosion problems with this equipment be reported so that the problem can be corrected and improvements made to prevent the problem in future equipment.

While corrosion is typically associated with rusting metal, it can also include deterioration of other materials such as contacts, injection-molded plastic, and foam inserts in the case. Unusual cracking, softening, swelling, or breaking of these other materials may be a corrosion problem.

**1-8 CORROSION PREVENTION AND CONTROL (CPC) - Continued**

If a corrosion problem is identified, report it using Standard Form 368, Product Quality Deficiency Report. Use keywords such as "corrosion," "rust," "deterioration," or "cracking" to ensure that the information is identified as a CPC problem. Submit the form to the address specified in DA Pam 738-750.

**Section II. Equipment Description and Data.****1-9 EQUIPMENT CHARACTERISTICS, CAPABILITIES, AND FEATURES****WARNING****Equipment Limitations**

To avoid physical and equipment damage when using the NVG, carefully read and understand the following safety precautions.

- The NVG requires some night light (moonlight, starlight, etc.) to operate. The level of performance depends upon the level of light.
- Night light is reduced by passing cloud cover, while operating under trees, in building shadows, etc.
- The NVG is less effective viewing into shadows and other darkened areas.
- The NVG is less effective through rain, fog, sleet, snow, smoke, and other reflective material.
- The NVG will not "see" through dense smoke.
- Adjust vehicular speed to prevent overdriving the range of view when conditions of possible reduction or loss of vision exist.

**CAUTION**

- The NVG is a precision optical instrument and must be handled carefully at all times to prevent damage.
- Be careful when leaving the helmet mount in the flipped up position or removing the helmet mount from the helmet, damage can result.

**WARNING**

The IR source is a light that is invisible to the unaided eye for use during conditions of extreme darkness. However, the light from the IR source can be detected by the enemy using night vision devices. The IR spot/flood lens accessory does not reduce the ability of an enemy to detect the illuminator.

## **1-9 EQUIPMENT CHARACTERISTICS, CAPABILITIES, AND FEATURES - Continued**

### **NOTE**

When utilizing the NVG for driving purposes, the goggles must not be used in the hand-held mode. The goggles must be worn in the headmounted or helmet mounted position.

The NVG is a hand-held, headmounted, or helmet mounted night vision system that enables walking, driving, weapon firing, short-range surveillance, map reading, vehicle maintenance, and administering first aid in both moonlight and starlight. Each unit allows for vertical adjustment (by using head strap), fore-and-aft adjustment, objective focus, eyepiece focus, and eye span distance adjustment. The goggles are also equipped with an IR source and a low-battery indicator. The NVG will not be turned off automatically when disconnected from the headmount or helmet mount. Turn off the NVG by the power switch. There is also a high light cut-off feature that cuts off power to the goggles when they are exposed to high levels of light for  $70 \pm 30$  seconds. Some units may be equipped with a removable compass and an IR spot/flood lens.

## **1-10 LOCATION AND DESCRIPTION OF MAJOR COMPONENTS**

### **a. Goggles.**

The goggles (Figure 1-2, Sheet 4) consist of four primary subassemblies: an objective lens, a wired housing, an image intensifier (not shown), and a rear cover. The wired housing contains a built-in battery compartment, attached battery cap, and the power switch. The goggles also use the accessories listed below.

(1) Demist Shields - The two demist shields are used to prevent the eyepiece lenses from becoming fogged.

(2) LIF - The LIF (Figure 1-2 Sheets 1-& 2) is to be used at all times. For replacing the filter, the container is also the wrench. The container/wrench is used to remove and replace the LIF from the objective lens.

(3) Sacrificial Window - A replaceable sacrificial window (Figure 1-2, Sheet 4) is supplied to protect the objective lens during operation in adverse conditions.

(4) IR Spot/Flood Lens – This additional authorized item (AAL) (Figure 1-2, Sheet 4) focuses the IR light for a narrow beam (spot) or wide-angle (flood) beam illumination.

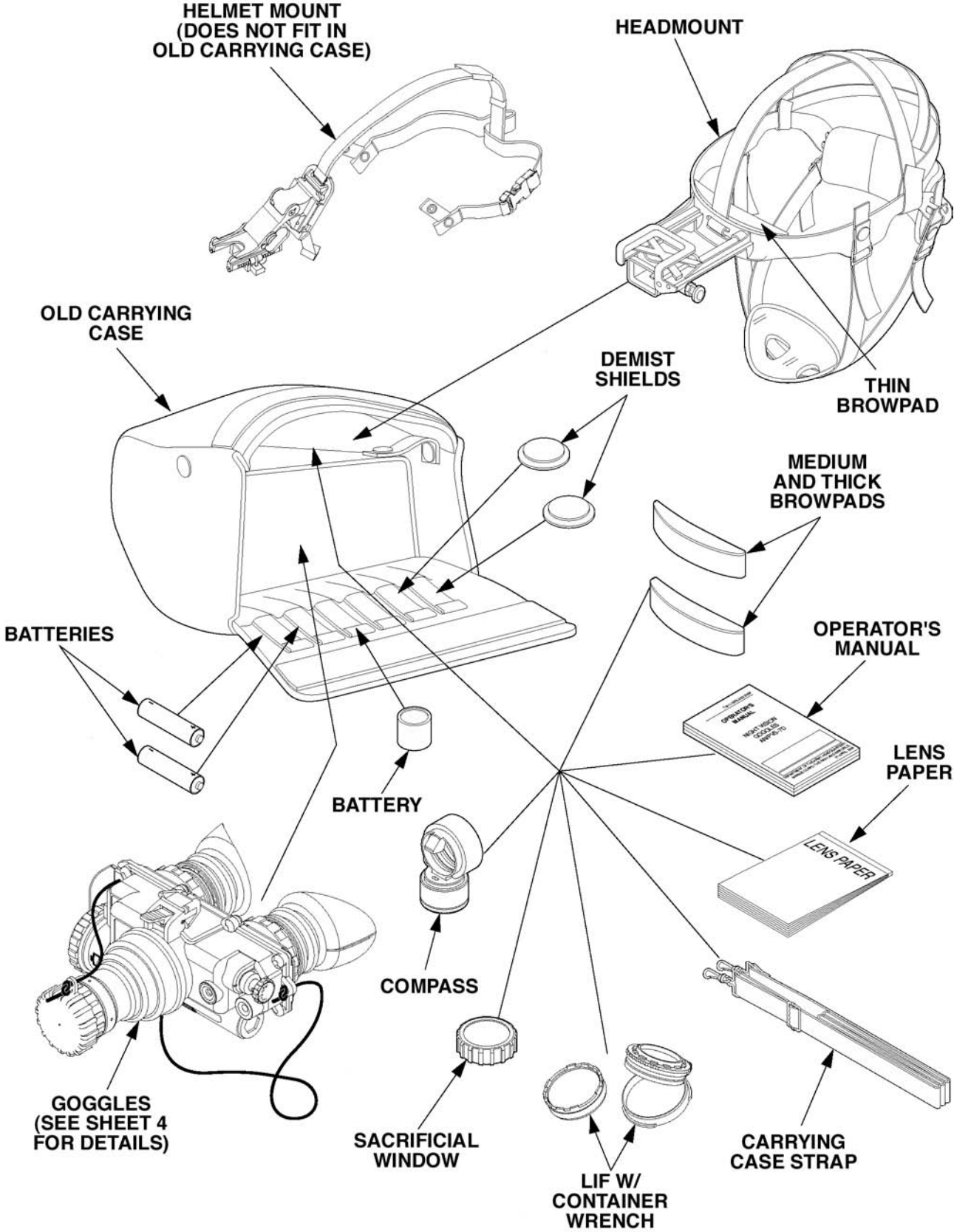

Figure 1-2. Night Vision Goggles (NVG) (Sheet 1 of 4).

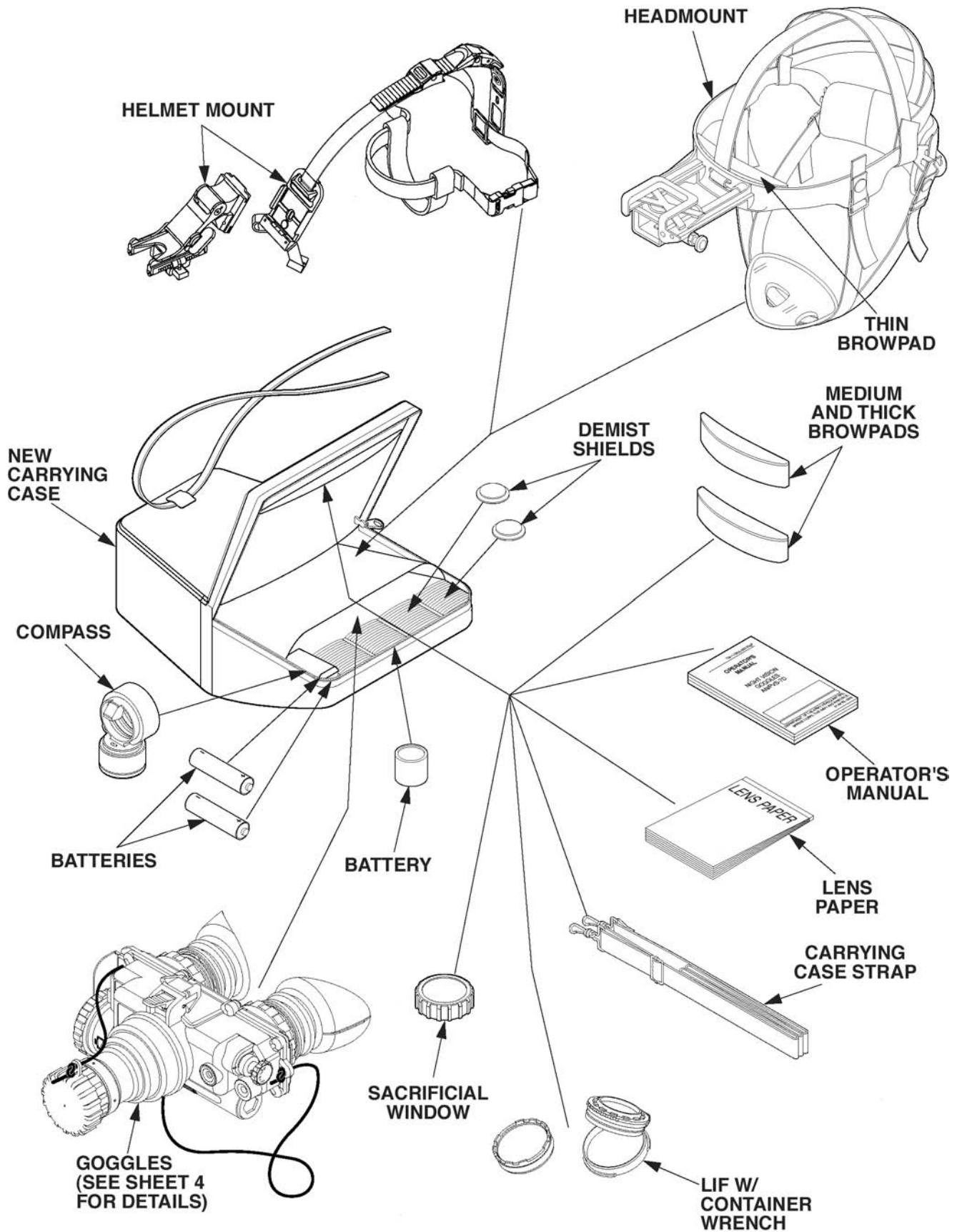

Figure 1-2. Night Vision Goggles (NVG) (Sheet 2 of 4).

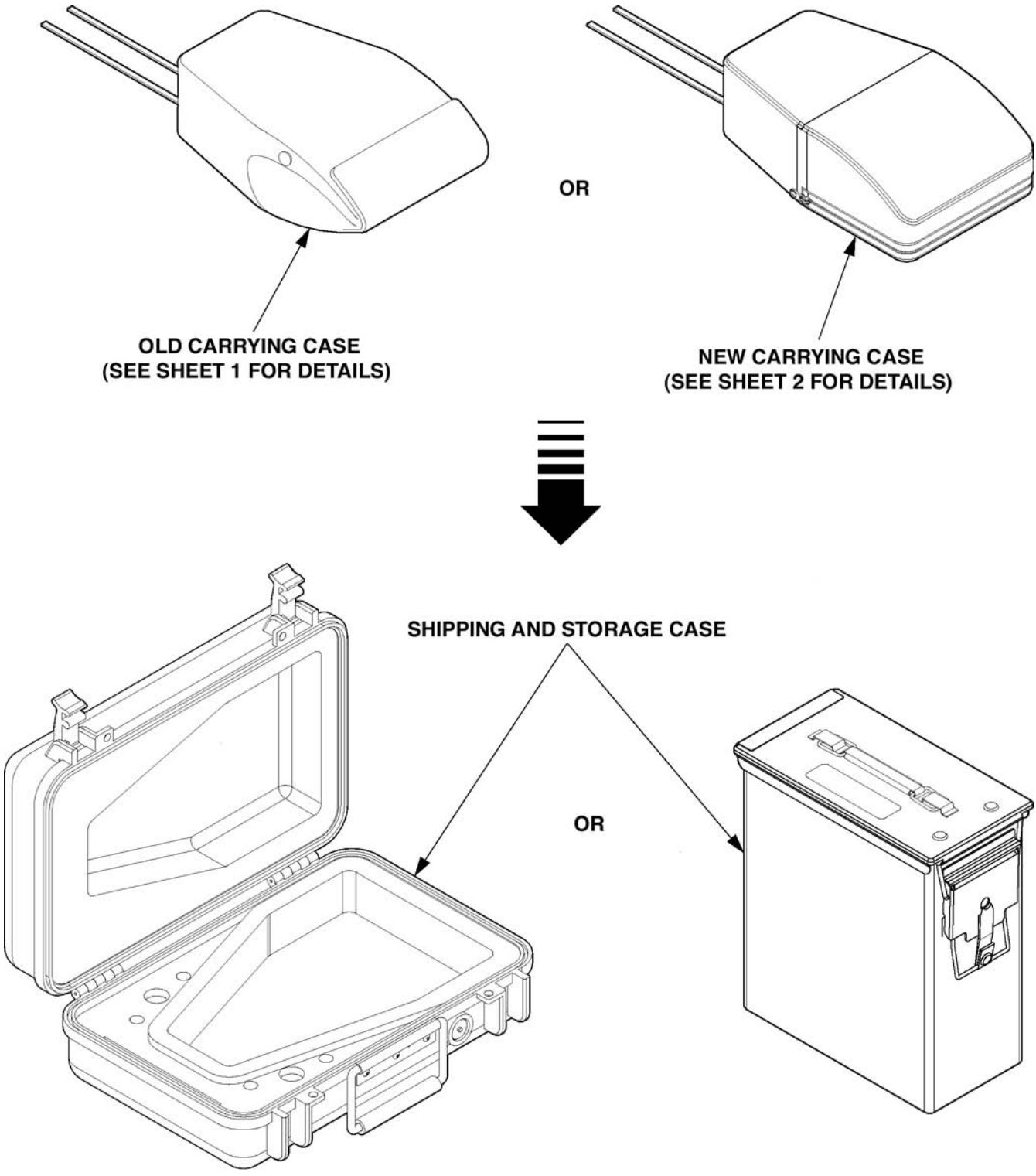

Figure 1-2. Night Vision Goggles (NVG) (Sheet 3 of 4).

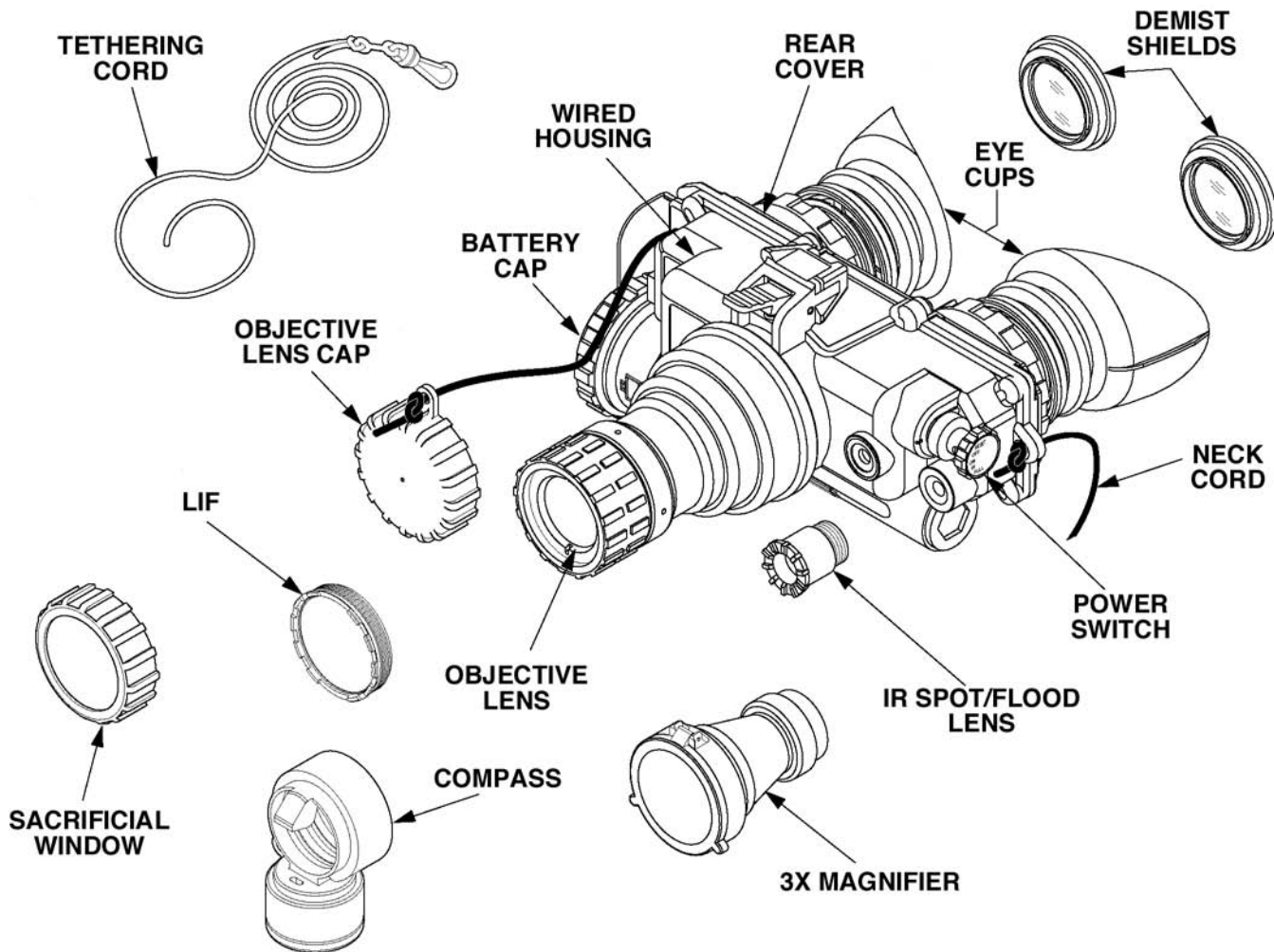

Figure 1-2. Night Vision Goggles (NVG) (Sheet 4 of 4).



## 1-10 LOCATION AND DESCRIPTION OF MAJOR COMPONENTS - Continued

(5) **Compass** – This item (Figure 1-2, Sheets 1, 2 and 4) enables the operator to see azimuth readings in the goggle’s viewing area. It is an AAL item for the AN/PVS-7B. It is a Component of End Item (COEI) of the AN/PVS-7D.

(6) **Tethering Cord** – This AAL item (Figure 1-2, Sheet 4) enables the user to attach the compass or 3X-magnifier to his/herself to guard against dropping or losing these items.

(7) **3X Magnifier** – (AAL Item) The 3X magnifier (Figure 1-2, Sheet 4) is a lens assembly, which can be added to the objective lens to extend the operator’s observation ranges.

**b. Headmount.** The headmount (Figure 1-2, Sheets 1 and 2) secures the goggles to the operator’s head for night viewing, and provides freehand support for use with a weapon, protective mask or other purposes. It is adjustable and cushioned. The thin browpad used for large heads, comes attached to the headmount and the thick or medium browpads are stored in the carrying case.

**c. Helmet Mount.** The helmet mount secures the goggles to the Personal Armor System Ground Troops (PASGT) helmet, allowing freehand support for use with a weapon, protective mask or other purposes. The new helmet mount is made of a ruggedized metal. The old one is made of plastic. The metal helmet mount is the only replacement available. There are four configurations of the helmet mount. The old helmet mount (Figure 1-2, Sheet 1) attaches to the helmet using a strap and catch assembly. The later two helmet mounts include a clip on/clip off feature, which allows for quick removal and installation. The AN/PVS-7D helmet mount (Figure 1-2, Sheet 2) consists of a goggle mount and a helmet mount bracket.

**d. Carrying Cases.** The canvas carrying case is provided for transportation and protection of the goggles, headmount, batteries and accessories. Two slide keepers are provided for belt attachment and three D-rings for shoulder and leg strap attachment. A carrying case strap is also provided which can be attached to the two D-rings on the back of the carrying case. There are two styles of carrying cases. The old case (Figure 1-2, Sheets 1 and 3 of 4) has a hook and pile closure, and the new case (Figure 1-2, Sheets 2 and 3 of 4) has a zipper closure.

**e. Shipping and Storage Case.** The NVG are supplied in a shipping and storage case (Figure 1-2, Sheet 3 of 4). Batteries (not furnished) may be stored in the shipping and storage case.

## 1-11 CONFIGURATION OF IMAGE INTENSIFIER

There are three types of image intensifiers (Figure 1-3). The MX-10130B is flat on the back end where the label is located and the two gold-colored contacts are round. The MX-10130C has raised tabs on the back end and the two contacts are oblong with a small hole in one side of each contact. The MX-10130D is mechanically identical to the MX-10130C but has higher resolution and improved visual quality.

### NOTE

The MX-10130A image intensifier (not shown) used in the AN/PVS-7A goggles will not work in the AN/PVS-7B and AN/PVS-7D.

**1-11 CONFIGURATION OF IMAGE INTENSIFIER - Continued**

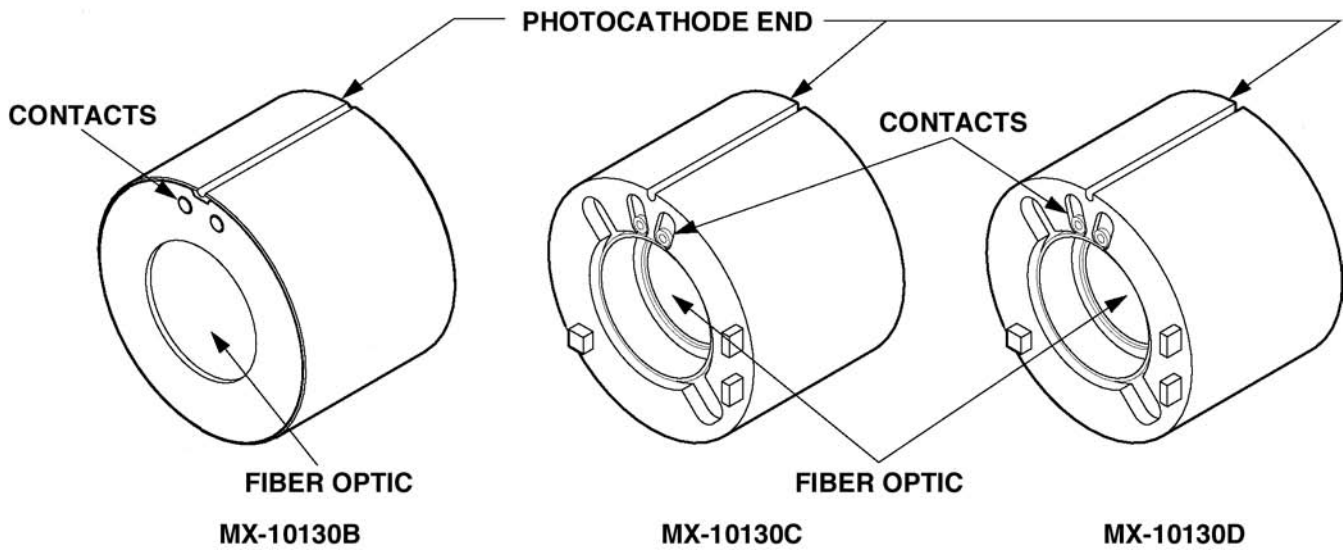

**Figure 1-3. Differences in Image Intensifier Types.**

**1-12 EQUIPMENT DATA**

The following tables provide information pertaining to the operational, electrical, mechanical, optical, and environmental characteristics for the goggles.

**Table 1-2. Operator Adjustment Limits.**

ITEM	LIMITS
Interpupillary Distance	55 to 71 mm
Diopter Focus	+2 to -6 diopters
Objective Focus	25 cm to infinity

**Table 1-3. Electrical Data.**

ITEM	DATA
Power Source	Battery (3 Vdc max)
Battery Requirements	2 ea. 1.5 Vdc AA Alkaline 6135-00-985-7845 -or- 2 ea. 1.5 Vdc AA Lithium L91 6135-01-333-6101 -or- 1 ea. 3 Vdc Lithium (BA-5567/U) 6135-01-090-5365

**1-12 EQUIPMENT DATA - Continued**

**Table 1-4. Mechanical Data.**

ITEM	CHARACTERISTICS
Shipping and Storage Case (Old)	Size: Approx. 17"w x 12"d x 7"h Weight: 6.7 lbs.
Shipping and Storage Case (New)	11.75"w x 6.25"d x 13"h Weight: 7.5 lbs.
Carrying Case (Canvas)	Size: Approx. 8"w x 4"d x 14"h
Goggles (see Note)	Weight: 1.5 lbs.

**NOTE:** Weight of NVG does not include accessories.

**Table 1-5. Optical Data.**

ITEM	DATA
Magnification	1.0X (3X with magnifier)
Field-of-View	40° (13° with 3X magnifier)
Diopter Adjustment	+2 to -6 diopters
Focus Range	25 cm (7.9") to infinity

**Table 1-6. Environmental Data.**

ITEM	DATA
Goggles Operating Temperature	-60°F to +113°F
Goggles Storage Temperature	-60°F to +160°F
Illumination Required	Overcast starlight to moonlight

Section III. Principles of Operation.

**1-13 MECHANICAL FUNCTIONS**

The mechanical functions of the goggles allow for differences in the physical features of individual operators and provide for operating the NVG. These functions include the power switch, interpupillary adjustment, eye relief adjustment, diopter adjustment, objective focus, IR spot/flood lens, compass illumination button (underneath) and a latch, to attach or remove from mounts. The mechanical controls are identified in Figure 1-4.

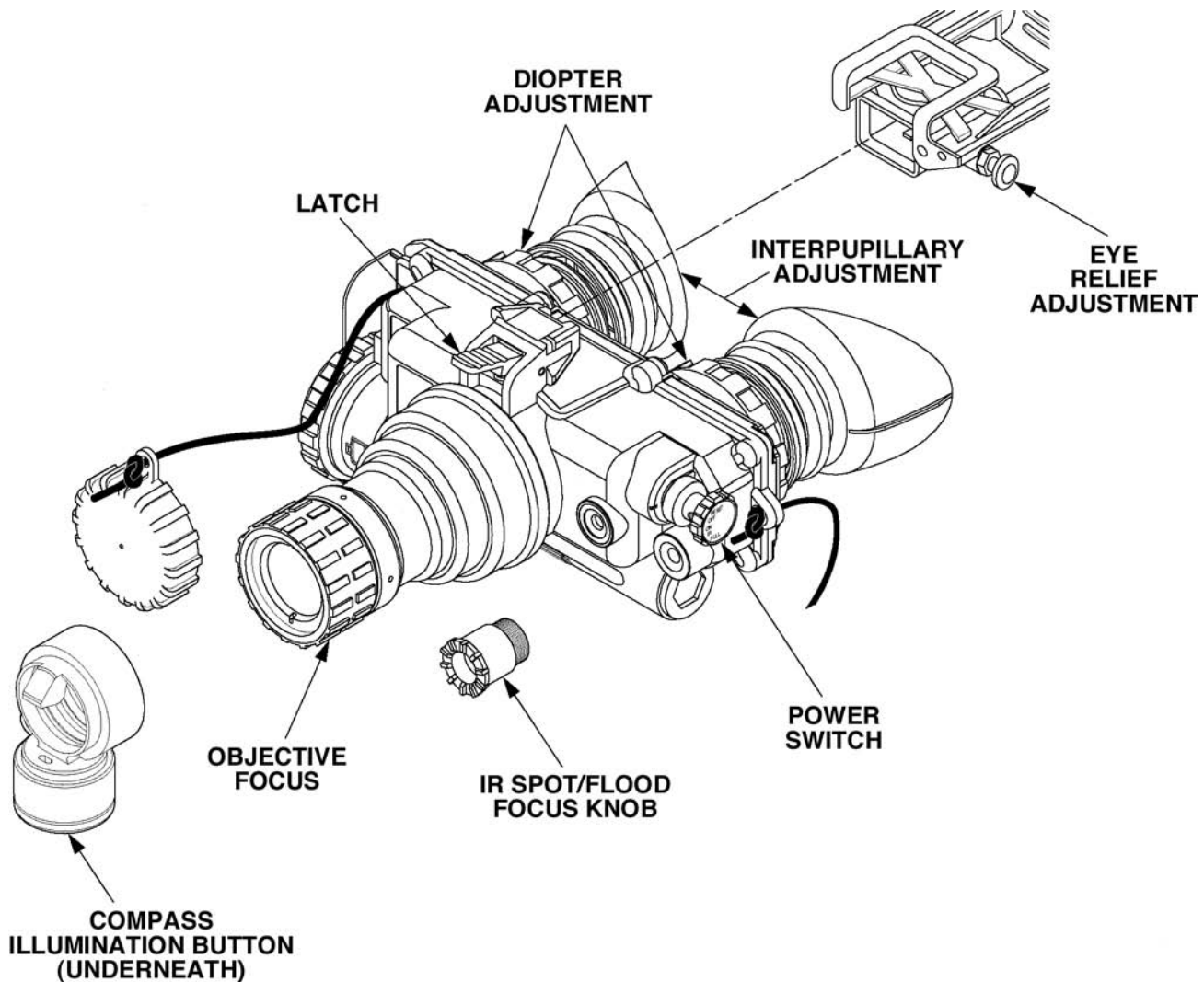

Figure 1-4. Mechanical Controls.

**1-14 OPTICAL FUNCTIONS**

The optical functions include an objective lens, an image intensifier, a collimator and two eyepiece lenses (Figure 1-5). The objective lens collects light reflected from the night scene by the moon, stars, or night sky, inverts the image and focuses that image on the image intensifier. The image intensifier converts the captured light into a visible image, which is then split and re-inverted by the collimator and transmitted to the eyepiece lenses for viewing.

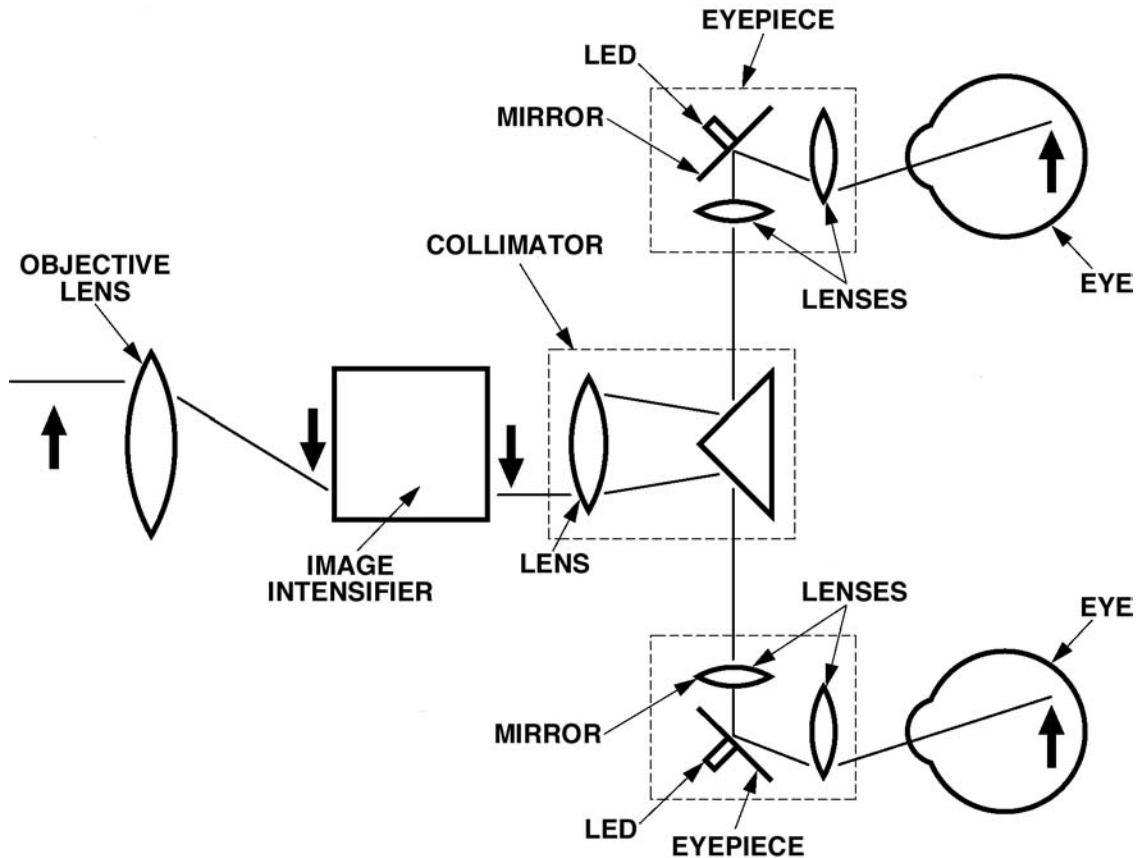

Figure 1-5. Optical Function Diagram.

**1-15 ELECTRONIC CIRCUIT FUNCTIONS**

The electronic circuit (Figure 1-6) regulates the direct current voltage from the batteries to the image intensifier and IR source as required. It also monitors the output voltage of the batteries and turns on a low-battery indicator in the right eyepiece when the battery life remaining is approximately 30 minutes (2.4 Vdc).

- a. **Power Source.** The electronic circuit is powered by replaceable batteries - either a 3.0-volt lithium battery (BA-5567/U), two AA 1.5-volt alkaline batteries, or two AA 1.5-volt lithium L91 batteries.

**1-15 ELECTRONIC CIRCUIT FUNCTIONS - Continued**

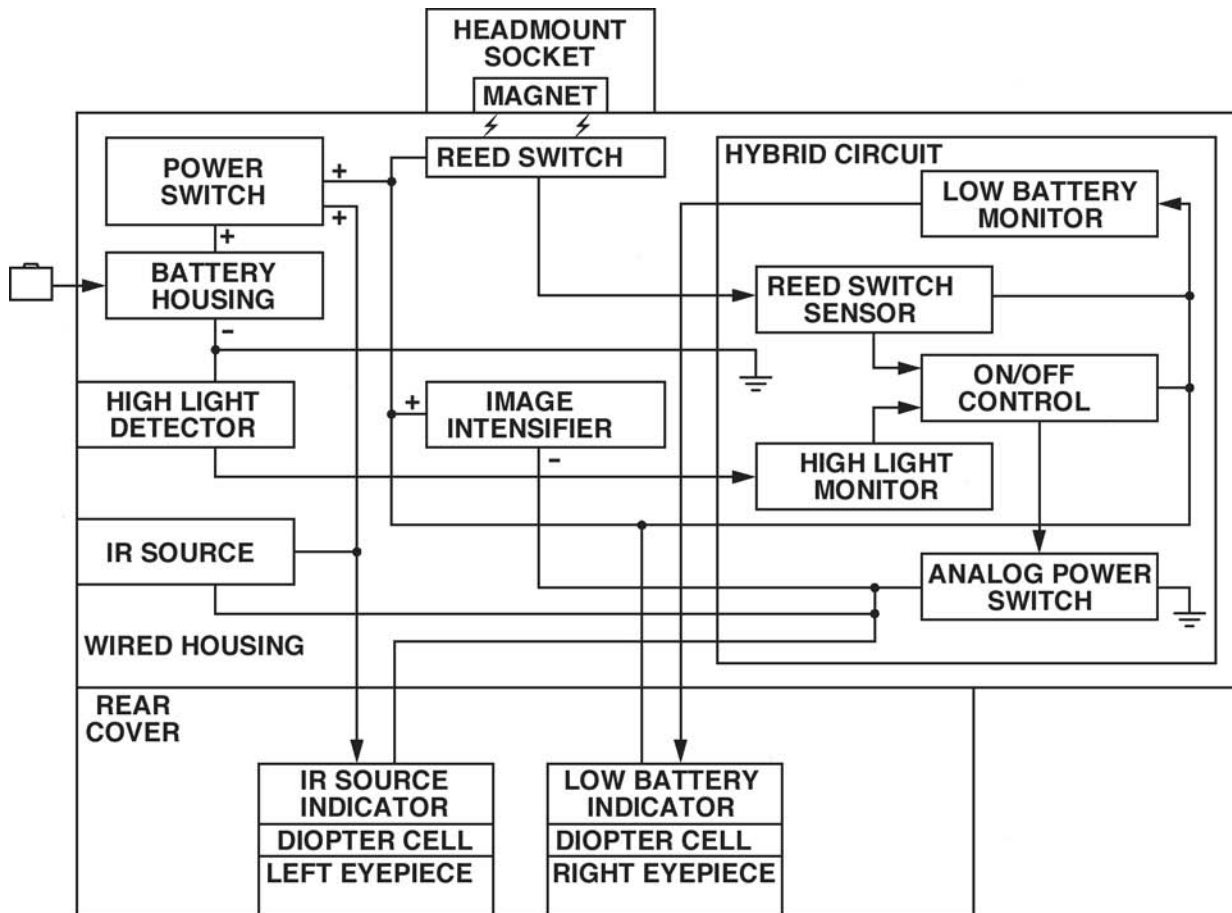

**Figure 1-6. Electronic Block Diagram.**

**b. Electrical Function.** Power from the batteries is supplied to the components through the power switch as follows:

**RESET/OFF Position** With the power switch in the OFF position, the circuit is not energized from either the image intensifier or the IR source. Also, turn the power switch to this position to rest after high light cut-off.

**ON Position** — Power is drawn from the battery compartment to energize the goggles. When the voltage drops to 2.4 Vdc, a low-battery indicator at the right eyepiece blinks indicating approximately 30 minutes of operating time.

**1-15 ELECTRONIC CIRCUIT FUNCTIONS - Continued****WARNING**

The IR source is a light that is invisible to the unaided eye for use during conditions of extreme darkness. However, the light from the IR source can be detected by the enemy using night vision devices.

**CAUTION**

Do not use excessive force to place the power switch into the momentary IR position.

**NOTE**

Some goggles contain an additional momentary IR function. For momentary IR, continue to turn the power switch clockwise; past ON and without pulling. The power switch will return to the ON position when released.

IR/PULL Position — Power is drawn from the battery compartment to energize the goggles and IR light source and a steady red indicator light in the left eyepiece.

**c. Automatic Shutoff.** When the goggles are removed from the headmount or helmet mount while in operation or flipped up in the mount, they will automatically shut off. To turn the goggles back on, turn the power switch to RESET/OFF and then to ON again.

**d. High light Cut-off.** The goggles will automatically cut off after  $70 \pm 30$  seconds of operation in daylight or bright room light, except in fluorescent lighting. Individual bright lights (headlights, flashlights, or other concentrated light sources) will not actuate the high light detector located on the front of the goggles. To turn the goggles back on, turn the power switch to RESET/OFF position and then to ON again.

## CHAPTER 2 UNIT MAINTENANCE INSTRUCTIONS

	<u>Page</u>
Overview .....	2-1
Common Tools and Equipment .....	2-1
Special Tools, TMDE, and Support Equipment.....	2-2
Repair Parts .....	2-2
Site and Shelter Requirements.....	2-2
Service Upon Receipt of Material .....	2-2
Installation.....	2-3
Preventive Maintenance Checks and Services (PMCS) Table .....	2-3
Inspection Criteria for Proper Image Intensifier Operation .....	2-3
Troubleshooting .....	2-3
Resolution Check Using the TS-4348/UV Test Set.....	2-3
Removal and Installation of Components .....	2-3
Removal and Installation of Battery Cap Assembly and Battery Cap Retainer .....	2-4
Removal and Installation of Browpads .....	2-4
Removal and Installation of Neck Pad.....	2-4
Removal and Installation of Chinstrap .....	2-6
Removal and Installation of Cross-strap.....	2-6
Removal and Installation of Power Switch Knob.....	2-8
Removal and Installation of Magnet on Metal Helmet Mount.....	2-8
Repainting and Refinishing Requirements.....	2-10
Lubrication Requirements .....	2-10
Packing the NVG.....	2-10

### **OVERVIEW**

This chapter contains maintenance procedures that are the responsibility of Unit Maintenance. Operation instructions and operator maintenance can be found in TM 11-5855-262-10-2 and are not repeated in this chapter.

The Unit level tasks include routine inspections, cleaning, visual inspection of image intensifier performance, optional resolution test using the TS-4348/UV test set, and repair by removing and replacing the headmount, headmount straps, and browpads, helmet mount, carrying case, sacrificial window, demist shields, neck cord, eyecups, objective lens cap, battery cap, IR spot/flood lens, and compass.

### **Section I. Repair Parts, Tools, Special Tools, TMDE, and Support Equipment.**

#### **2-1 COMMON TOOLS AND EQUIPMENT**

For authorized common tools and equipment, refer to the Modified Table of Organization and Equipment (MTOE), CTA 50-970, or CTA 8-100, as applicable to your unit.



## **2-2 SPECIAL TOOLS, TMDE, AND SUPPORT EQUIPMENT**

Refer to Appendix B for the Maintenance Allocation Chart (MAC) for authorized maintenance and to Appendix C for the Repair Parts and Special Tools List (RPSTL) for information on special tools, Test, Measurement, and Diagnostic Equipment (TMDE), and support equipment required at unit maintenance. In addition, instructions or a fabricated black spot test fixture are contained in Appendix E.

## **2-3 REPAIR PARTS**

Repair parts are listed and illustrated in Appendix C of this manual.

### **Section II. Service Upon Receipt.**

## **2-4 SITE AND SHELTER REQUIREMENTS**

The checks and service functions, as prescribed herein, should be accomplished in the electronic repair service area. A standard electronic workbench provides an adequate working area for NVG maintenance requirements. The surface area should be free of chemicals, vapors, and emissions that may damage external parts of the goggles. Normal sheltering from the elements (cold, rain, dust, etc.) is necessary. There should be provisions to perform certain service functions and specified tests in a dark room or dark area in which all places where light can enter (e.g., windows, doors, wall and ceiling joints) have been blocked. This blocking can be accomplished using either permanent or temporary shields such as tape or heavy curtains. The room or area should appear dark (without the evidence of light entering the area) to your unaided eye after approximately 10 minutes of dark adaptation. Use a night vision device to identify and isolate the place where light enters.

## **2-5 SERVICE UPON RECEIPT OF MATERIAL**

### **NOTE**

The NVGs are precision electro-optical instruments and must be handled carefully at all times to prevent damage.

a. Inspect the NVG for possible damage incurred during shipment. If the NVG have been damaged, report the damage on SF 364, Report of Discrepancy.

b. Check the NVG against the packing slip to see if the shipment is complete. Report all discrepancies in accordance with the instructions of DA Pam 738-750. Marine Corps personnel refer to MCO P4610.19, Reporting of Transportation Discrepancies in Shipments.

c. Refer to DA Pam 25-30 Consolidated Index of Army Publications and Blank Forms, to determine whether there are modification work orders (MWOs) pertaining to the NVG.

d. Upon receipt of a newly fielded NVG, fill out a hard copy DD Form 314 (IAW DA Pam 738-750) for that system. The first 180-day service is penned in using the warranty date minus 30 months, then pencil in when the next 180-day service is due. All used NVGs received by the unit must have a 180-day service performed. If using an automated system such as SAMS or ULLS, use the equivalent electronic form, and track using the same procedure as for the hard copy DD Form 314.

**2-6 INSTALLATION**

Installation instructions are contained in TM 11-5855-262-10-2; Operator's Manual for Night Vision Goggles (NVG), AN/PVS-7B and AN/PVS-7D.

**Section III. Preventive Maintenance Checks and Services.**

**2-7 PREVENTIVE MAINTENANCE CHECKS AND SERVICES (PMCS) TABLE**

Preventive maintenance checks and services are listed in TM 11-5855-262-10-2; Operator's Manual for Night Vision Goggles (NVG), AN/PVS-7B and AN/PVS-7D.

**2-8 INSPECTION CRITERIA FOR PROPER IMAGE INTENSIFIER OPERATION**

Inspection criteria for proper image intensifier operation are contained in TM 11-5855-262-10-2; Operator's Manual for Night Vision Goggles (NVG), AN/PVS-7B and AN/PVS-7D.

**Section IV. Troubleshooting.**

**2-9 TROUBLESHOOTING**

Information pertaining to troubleshooting the goggles is listed in TM 11-5855-262-10-2, Operator's Manual for Night Vision Goggles (NVG), AN/PVS-7B and AN/PVS-7D.

**2-10 RESOLUTION CHECK USING THE TS-4348/UV TEST SET**

Procedures designed to check the performance of the image intensifier are listed in TM 11-5855-262-10-2; Operator's Manual for Night Vision Goggles (NVG), AN/PVS-7B and AN/PVS-7D.

**Section V. Maintenance Procedures.**

The following components of the NVG are authorized for removal and replacement at the unit level.

**2-11 REMOVAL AND INSTALLATION OF COMPONENTS**

The procedures for the removal and installation of the following items can be found in TM 11-5855-262-10-2, Operator's Manual for Night Vision Goggles (NVG), AN/PVS-7B and AN/PVS-7D.

- a. Objective Lens Cap
- b. Eyecups
- c. Carrying case and carrying case strap
- d. Batteries
- e. Headmount
- f. Helmet mount
- g. Compass
- h. IR Spot/Flood Lens
- i. Neck cord

## **2-12 REMOVAL AND INSTALLATION OF BATTERY CAP AND BATTERY CAP RETAINER**

Inspect battery cap, retainer and O-ring for damage or loss. If damaged or missing, replace battery cap/ battery cap retainer or O-ring per following:

- (1) Inspect O-ring and replace if necessary.
- (2) Inspect battery cap for damage or corrosion, clean and/or replace as necessary.
- (3) Inspect battery cap retainer and replace as follows:
  - (a) Remove old battery cap retainer by cutting with wire cutters.

### **CAUTION**

If wired body pin is broken, turn in to Direct Support.

(b) Examine the battery housing for the presence of a link around the pin between the rear cover and the battery housing. If a link is present it must be removed by carefully clipping with wire cutters - do not cut the pin. Examine the pin between the rear cover and the battery housing. If the pin is missing or damaged - turn the goggles over to direct support. If the pin is present, slide a sleeve onto the wire, insert one end of the wire around the pin, and then back down through the sleeve. Align the sleeve and the wire so that the sleeve is approximately one-eighth inch away from the pin and one-eighth inch of the short end of the wire protrudes from under the sleeve. Once positioned, crimp the sleeve with needle nose pliers, so that the sleeve firmly holds both parts of wire in place. Repeat the process at the other end of the wire around the battery cap stud.

## **2-13 REMOVAL AND INSTALLATION OF BROWPADS**

- (1) Remove old browpad (Figure 2-1) by grasping the headband and peeling off the old browpad.
- (2) Replace browpad by gently pressing on the new browpad and smoothing out any wrinkles in new browpad.

## **2-14 REMOVAL AND INSTALLATION OF NECK PAD**

- (1) Remove vertical adjustment (Figure 2-1) from sliding bar buckle at rear of neck pad.
- (2) Remove right chinstrap from sliding bar buckle on right side of neck pad. Remove left snap assembly from left side of neck pad.
- (3) Unlace neck pad straps (Figure 2-2) from strap retaining tabs in headband (Figure 2-1).
- (4) Replace neck pad by lacing straps as shown in Figure 2-2. Lift upper strap retention tab to allow neck pad strap to be inserted into fastener area.

**2-14 REMOVAL AND INSTALLATION OF NECK PAD - Continued**

- (5) Slip neck pad strap under upper strap retention tab. Straighten strap, pulling strap under lower strap retention tab.
- (6) Repeat steps (4) and (5) for the other side of the neck pad and headband.

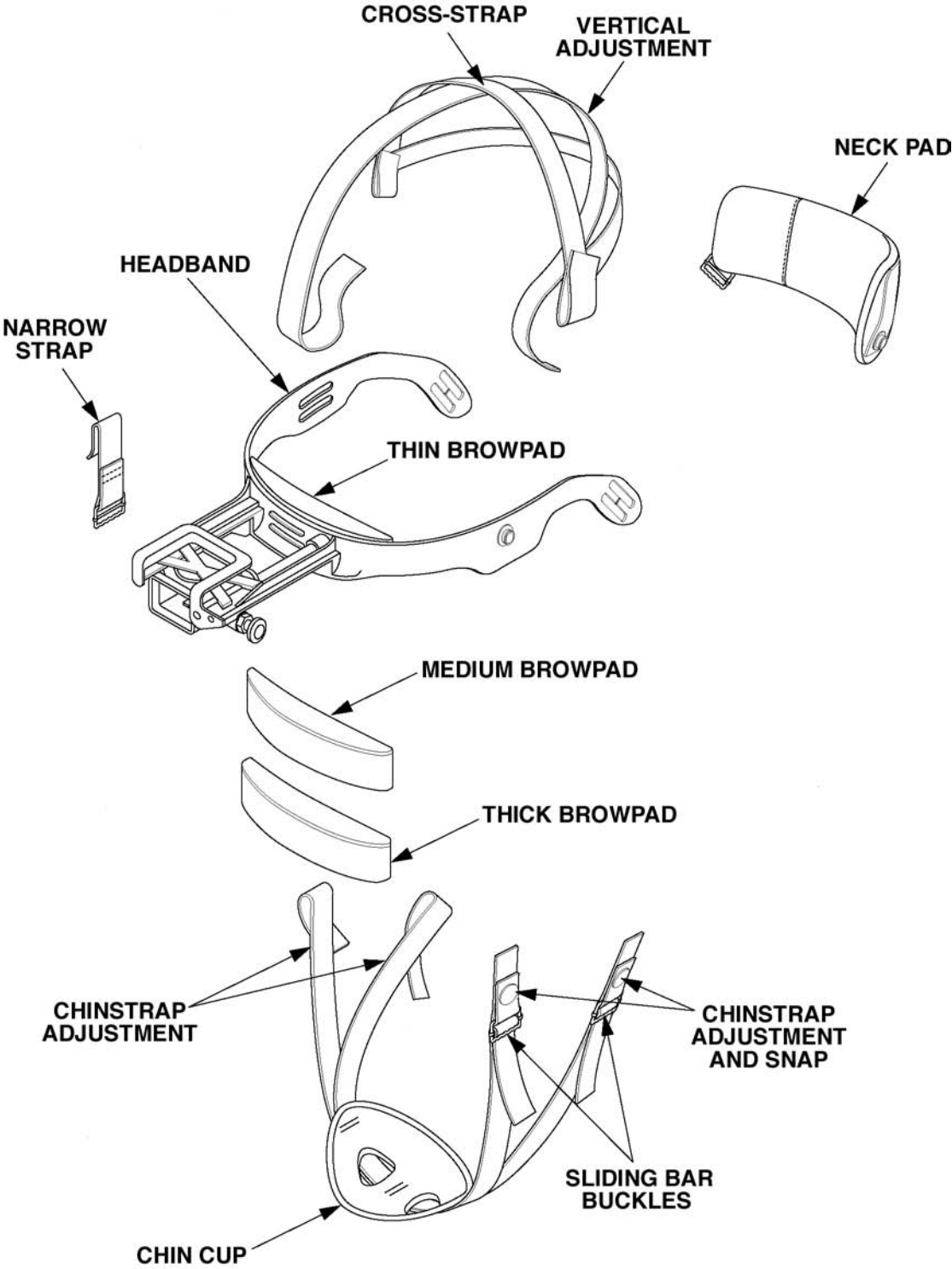
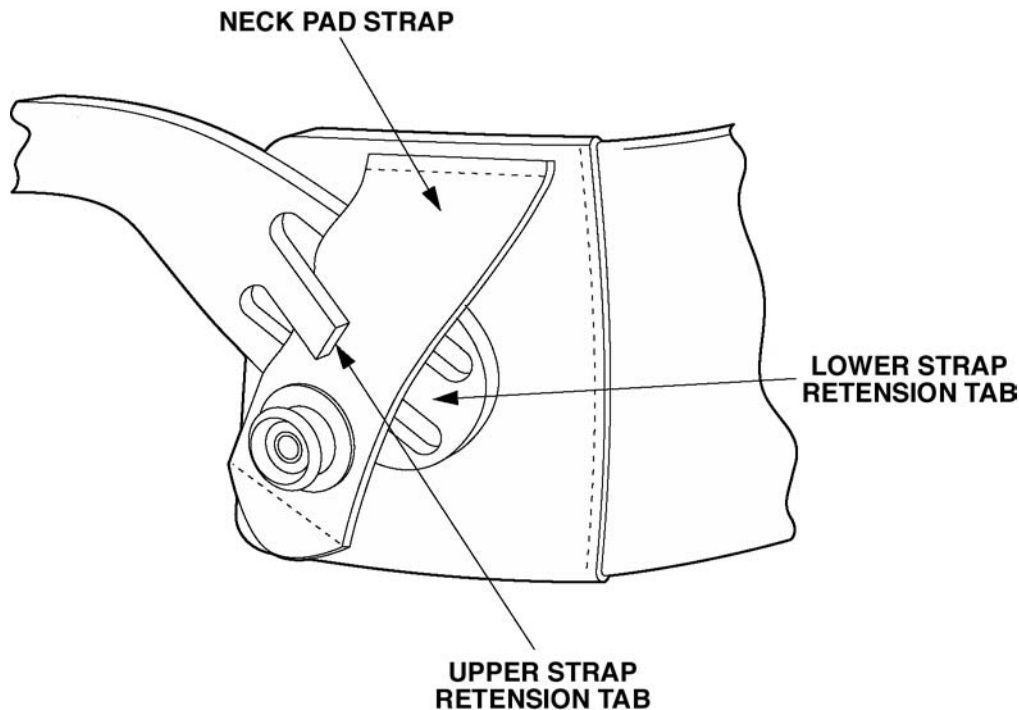

Figure 2-1. Headmount Components Removal and Replacement.

**2-14 REMOVAL AND INSTALLATION OF NECK PAD - Continued**



**Figure 2-2. Lacing of Right and Left Neck Pad Straps.**

**2-15 REMOVAL AND INSTALLATION OF CHINSTRAP**

(1) Remove chinstrap (Figure 2-1) by unsnapping the two snaps from the left side of the headband and neck pad. Unbuckle the chinstraps from narrow strap assembly and the right side of neck pad.

(2) Replace the chinstrap by installing the two snaps on the left side of the headband and neck pad. Lace the two right straps into their respective sliding bar buckles on the right side of the headband and neck pad for correct lacing. (Figure 2-3)

**2-16 REMOVAL AND INSTALLATION OF CROSS-STRAP**

(1) Remove browpad (para 2-13).

(2) Remove neck pad (para 2-14).

(3) Remove cross-strap front strap from headband (Figure 2-1) by unthreading strap from headband slots.

(4) Slide strap free of headband by sliding the left and right strap loops off at rear of headmount.

**2-16 REMOVAL AND INSTALLATION OF CROSS-STRAP - Continued****NOTE**

The elastic straps should be on top of the vertical adjustment strap when headmount is properly installed.

- (5) Replace cross-strap by installing the left and right strap loops onto the headband. Thread cross-strap front strap through front top headband slot from inside headband. Pull strap out and thread back through bottom slot.

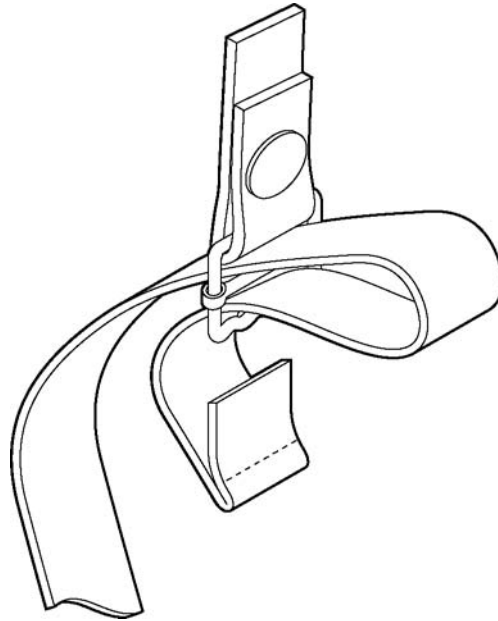

**Figure 2-3. Lacing of Sliding Bar Buckles.**

- (6) Replace neck pad (para 2-14).
- (7) Attach chinstrap right rear strap to right sliding bar buckle on neck pad.
- (8) Attach chinstrap assembly (Figure 2-1) left rear snap to mating fastener on neck pad.
- (9) Attach cross-strap vertical adjustment into mating sliding bar buckle attached to center outside of neck pad.
- (10) Replace browpad (para 2-13).

## **2-17 REMOVAL AND INSTALLATION OF POWER SWITCH KNOB**

The power switch knob can be replaced without disturbing any of the goggles' assemblies. One lock pin secures the knob to the shaft.

---

### **INITIAL SETUP**

#### Test Facility

Standard workbench in the electronic repair service area

#### Tools

Hex wrench .050", (Appendix B, Item 11)

#### Materials/Parts

Power Switch Knob (Appendix C, Figure C-2, Item 12)

---

### **REMOVAL**

- (1) With a hex wrench .050", remove knob lock pin by turning counterclockwise.
- (2) Remove knob (Figure 3-9).

### **INSTALLATION**

- (1) Position knob on switch shaft. Align lock pin hole in knob with lock pin hole in shaft.
- (2) Insert lock pin into knob and use a hex wrench .050" to tighten lock pin hand tight.

## **2-18 REMOVAL AND INSTALLATION OF MAGNET ON METAL HELMET MOUNT**

### **INITIAL SETUP**

#### Test Facility

Standard workbench in the electronic repair service area

#### Tools

Hex wrench 5/64", (Appendix B, Item 11)

---

#### Materials/Parts

None

**2-18 REMOVAL AND INSTALLATION OF MAGNET ON METAL HELMET MOUNT -  
Continued****REMOVAL**

- (1) With the 5/64". hex wrench, remove the two screws located behind the socket.
- (2) Remove the magnet on the metal helmet mount.

**INSTALLATION**

- (1) Position the magnet by aligning with the holes in the metal helmet mount and insert the two screws (Figure 2-4).
- (2) Use the 5/64". hex wrench to tighten the two screws hand tight.

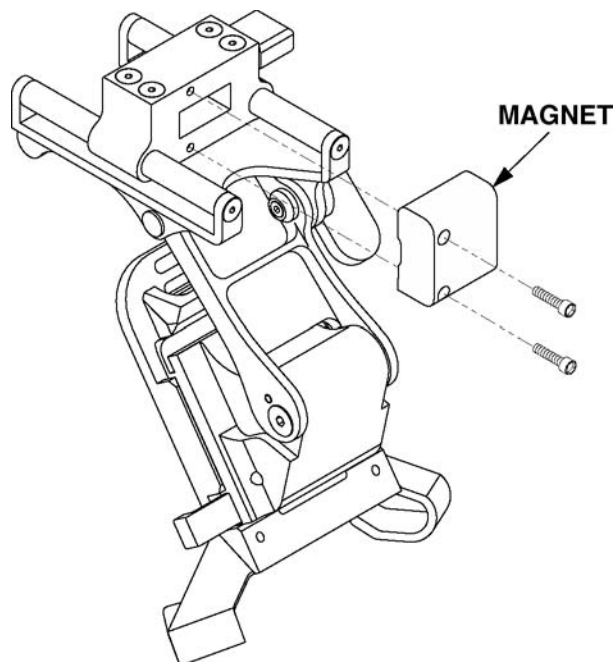

**Figure 2-4. Magnet, Metal Helmet Mount.**



**2-19 REPAINTING AND REFINISHING REQUIREMENTS**

Unit maintenance personnel are not authorized or required to repaint or refinish any component of the goggles, accessories, carrying case or shipping and storage case.

**2-20 LUBRICATION REQUIREMENTS**

The only lubrication authorized at this level is lubrication of the battery cap O-ring. See Appendix D, Item 2.

**Section VI. Preparation for Storage and Shipment.**

**2-21 PACKING THE NVG**

Packing procedures are provided in TM 11-5855-262-10-2, Operator's Manual for Night Vision Goggles (NVG), AN/PVS-7B and AN/PVS-7D.

## CHAPTER 3 DIRECT SUPPORT MAINTENANCE INSTRUCTIONS

	<u>Page</u>
Overview .....	3-1
Common Tools and Equipment .....	3-1
Special Tools, TMDE, and Support Equipment.....	3-1
Repair Parts .....	3-2
Site and Shelter Requirements.....	3-2
Service Upon Receipt of Material .....	3-2
Scope.....	3-2
Troubleshooting .....	3-3
TS-3895A/UV Preparation for Use .....	3-6
Testing the NVG Using TS-3895A/UV .....	3-6
Electrical Troubleshooting .....	3-10
Black Spot Check.....	3-12
Removal and Installation of Objective Lens.....	3-17
Objective Lens Infinity Focus Adjustment .....	3-20
Removal and Installation of Image Intensifier .....	3-20
Removal and Installation of Collimator .....	3-22
Removal and Installation of Wired Housing .....	3-26
Removal and Installation of Rear Cover .....	3-28
Purging.....	3-29
Operational Checks.....	3-33
Packing the NVG.....	3-33
Shipping the Image Intensifier.....	3-33

### **OVERVIEW**

Direct support maintenance personnel are authorized by the Maintenance Allocation Chart (MAC) to perform inspection, repair, and replacement procedures to return the goggles to operational status.

#### **Section I. Repair Parts, Tools, Special Tools, TMDE, and Support Equipment.**

### **3-1 COMMON TOOLS AND EQUIPMENT**

For authorized common tools and equipment, refer to the Modified Table of Organization and Equipment (MTOE), CTA 50-970, or CTA 8-100, as applicable to your unit.

### **3-2 SPECIAL TOOLS, TMDE, AND SUPPORT EQUIPMENT**

Refer to Appendix B for the Maintenance Allocation Chart (MAC) and to Appendix C for the Repair Parts and Special Tools List (RPSTL) for information on special tools, Test, Measurement, and Diagnostic Equipment (TMDE), and support equipment required at Direct Support Maintenance. In addition, instructions for a fabricated black spot test fixture are contained in Appendix E.

### **3-3 REPAIR PARTS**

Repair parts required by Direct Support Maintenance to maintain the NVG are listed and illustrated in Appendix C.

## **Section II. Service Upon Receipt.**

### **3-4 SITE AND SHELTER REQUIREMENTS**

Direct Support maintenance requirements for site and shelter are the same as those specified in paragraph 2-4, with the additional requirement of a clean station. The clean station is an area, which is dirt-free and environmentally controlled for temperature and humidity, such as a bench top, where you can repair and service the wired housing of the goggles. Because the clean station is where the wired housing is opened, exposing the inside lens surfaces and the optics of the image intensifier, it must be free of debris or any other material that can enter a disassembled system and contaminate it. The clean station does not require a flow hood.

### **3-5 SERVICE UPON RECEIPT OF MATERIAL**

Requirements for inspecting equipment are the same as those for Unit Maintenance (para 2-5).

## **Section III. Servicing.**

### **3-6 SCOPE**

#### **NOTE**

The TS-4348/UV Test Set can be used for the 180-day service PASS/FAIL resolution testing. When an image intensifier FAILS the resolution test using the TS-4348/UV Test Set, the system must be rechecked using the TS-3895A/UV Test Set. The TS-3895A/UV Test Set determines the final outcome of the image intensifier being tested.

Before an NVG is placed into use, it must receive the 180-day service if it is not a newly fielded system. A 180-day service is performed on the NVG by the Direct Support. This 180-day service consists of a PMCS, purging and a resolution test (using the TS-4348/UV or TS-3895A/UV). If a system Passes the resolution testing, no faults found during PMCS and is purged, then the NVG has met all requirements for the 180-day service using either test set. Refer to paragraph 2-7 for the PMCS checks. Instructions for the other servicing requirements are contained in this section.

#### **a. 180-Day Servicing.**

(1) **PMCS** – Refer to TM 11-5855-262-10-2, Operator's Manual for Night Vision Goggles (NVG), AN/PVS-7B and AN/PVS-7D.

(2) **Purging** – (para 3-18).

(3) **Resolution test** – For the TS-4348/UV, refer to TM 11-5855-262-10-2, Operator's Manual for Night Vision Goggles (NVG), AN/PVS-7B and AN/PVS-7D. For the TS-3895A/UV, refer to paragraph 3-9.

Section IV. Troubleshooting.

**3-7 TROUBLESHOOTING**

**CAUTION**

Maintenance for the NVG should be performed in an environment, which is as dust free as possible to protect optical assemblies and the image intensifier.

**a. Purpose of Troubleshooting.** Troubleshooting is required to isolate and identify defective assemblies in the NVG. Troubleshooting consists of performing inspections and operational checks to determine the symptom of the malfunction. The direct support troubleshooting table is then used to determine the probable cause, further troubleshooting instructions, and the required corrective action. Image intensifier malfunctions can be determined by using the TS-3895A/UV test set to assess image intensifier stability and resolution at high and low-illumination levels. Electrical troubleshooting consists of using a standard multimeter to determine failures in the wired housing, which could result in lack of power to the image intensifier.

**b. Direct Support Troubleshooting.** Table 3-1 is to be used as a guide for systematic and efficient procedures to isolate malfunctions in the goggles. This table cannot list all the malfunctions that may occur, all the tests and inspections needed to find the fault, or all the corrective actions needed to correct the fault. If the equipment malfunction is not listed or actions listed do not correct the fault, notify your supervisor.

**CAUTION**

Before proceeding with any corrective action, confirm that the goggles or image intensifier is out of the warranty period. Failure to utilize warranty coverage will result in excess charges to the unit (para 1-7).

**Table 3-1. Troubleshooting.**

PROBLEM	PROBABLE CAUSE	CORRECTIVE ACTION
No green glow observed in eyepiece (image intensifier not illuminated).	Batteries dead.	Replace batteries.
	Battery cap damaged.	Replace battery cap.
	Power switch not reset.	Turn power switch OFF and reset then back ON.
	Defective image intensifier or wired housing.	Perform electrical troubleshooting procedure (para 3-10).
Image not clear.	Dirty lens.	Clean the objective and eyepiece lens of the goggles by using isopropyl alcohol and cotton-tipped applicators. Moisten the applicator with the isopropyl alcohol

**3-7 TROUBLESHOOTING - Continued**

**Table 3-1. Troubleshooting - Continued.**

PROBLEM	PROBABLE CAUSE	CORRECTIVE ACTION
Image not clear (continued).		and use circular motions beginning at the center of the lenses and moving in larger circles to the outside of the lenses. Reset (para 3-13).
	Eyepiece out of focus.	Refocus eyepiece.
	Objective lens out of focus.	Refocus objective lens.
	Moisture in lenses.	Inspect for cracked housing or defective O-ring. Replace defective parts or assy and purge goggles (para 3-18).
	Optical system damaged.	Inspect each eyepiece and objective lens. Replace defective rear cover (para 3-17) or objective lens (para 3-12). If eyepieces and objective are OK, inspect collimator for scratches, cracks, chips or defects. Replace defective collimator. Check seating and alignment pin (para 3-15).
Image will not focus at or near infinity.	Objective infinity focus not adjusted.	Perform objective lens infinity focus adjustment (para 3-13).
Diopter adjustment cannot be made.	Defective rear cover.	Replace rear cover (para 3-17).
Interpupillary adjustment cannot be made.	Rear cover needs lubrication.	Remove rear cover and grease inside of rear cover with light coat of grease (para 3-17).
	Defective rear cover.	Replace rear cover (para 3-17).
IR illumination source not operative.	Defective wired housing.	Replace wired housing.

**3-7 TROUBLESHOOTING - Continued**

**Table 3-1. Troubleshooting - Continued.**

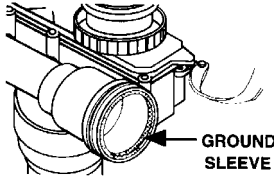
PROBLEM	PROBABLE CAUSE	CORRECTIVE ACTION
IR illumination indicator not operative.	LED dislodged.	Remove rear cover and light reinstall LED (para 3-17).
	Defective wired housing.	Replace wired housing.
Goggles do not cut off within 70 ±30 seconds in daylight or bright room light. Do not use fluorescent lighting.	Defective wired housing.	Replace wired housing.
Defective low-battery detection capability.	LED dislodged.	Remove rear cover and reinstall LED.
	Defective wired housing.	Replace wired housing.
	Defective LED indicator in eyepiece.	Replace wired housing.
Battery cap difficult to turn.	Defective battery cap.	Replace battery cap.
	Damaged threads or battery ground sleeve defective.	Replace wired housing.
		
Battery cap not secured to wired housing assy.	Battery cap's retainer link and/or strap defective or missing.	Replace battery cap retainer link or strap with wire kit. (para 2-12).
	Wired body pin is broken off.	Replace wired housing (para 3-16).
Goggles fail resolution test.	Objective infinity focus not properly set.	Set objective infinity focus (para 3-13).
	Eyepiece out of focus.	Refocus eyepiece.
	Moisture in main housing.	Inspect for cracked housing or defective O-ring. Replace defective parts or assy and purge goggles (para 3-18).
	Optical system damaged.	Inspect each eyepiece and objective lens. Replace defective rear cover or objective lens.

**3-7 TROUBLESHOOTING - Continued**

**Table 3-1. Troubleshooting - Continued.**

---

PROBLEM	PROBABLE CAUSE	CORRECTIVE ACTION
Goggles fail resolution test. (Cont)	Defective image intensifier.	Replace image intensifier (para 3-14).

---

**3-8 TS-3895A/UV PREPARATION FOR USE**

Use TM 11-5855-264-14, Operator's, Unit, Direct Support and General Support Maintenance Manual for TS-3895/UV and TS-3895A/UV Test Sets, to set up the test set and perform the self test.

**NOTE**

Before using the TS-3895A/UV, refer to TM 11-5855-264-14, to familiarize yourself with the operation, warnings, and cautions associated with that test equipment.

**3-9 TESTING THE NVG USING TS-3895A/UV**

---

**INITIAL SETUP**

Test Facility

Clean station in the electronic repair service area

Tools

None

Equipment

Test Set TS-3895A/UV (Appendix B, Item 2)  
Dispenser, Alcohol (Appendix D, Item 5)

Materials/Parts

Cotton-tipped applicators (Appendix D, Item 10)  
Isopropyl alcohol (Appendix D, Item 1)

---

**PROCEDURE**

- (1) Unpack the goggles and test set.
- (2) Clean the objective and eyepiece lenses of the goggles with cotton-tipped applicators and isopropyl alcohol.

**3-9 TESTING THE NVG USING TS-3895A/UV -Continued**

- (3) Review the location of major components (Figure 3-1).
- (4) Ensure that the test port lenses of the test set are clean and free of dirt.
- (5) Attach the large goggle adapter to either test port and cover other test port.

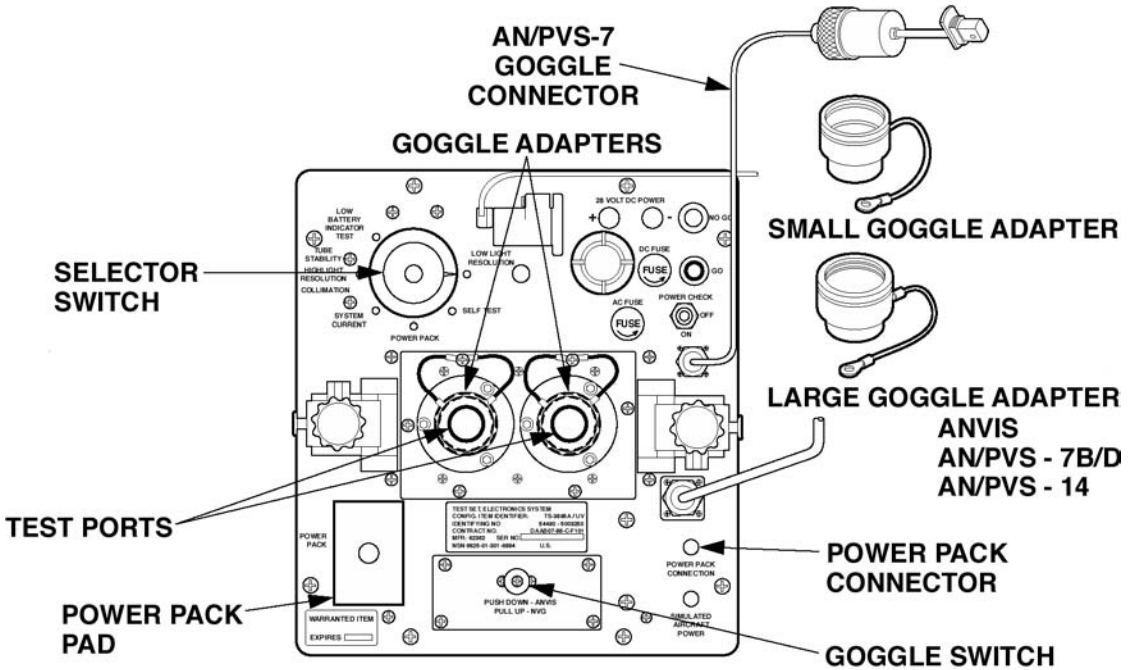
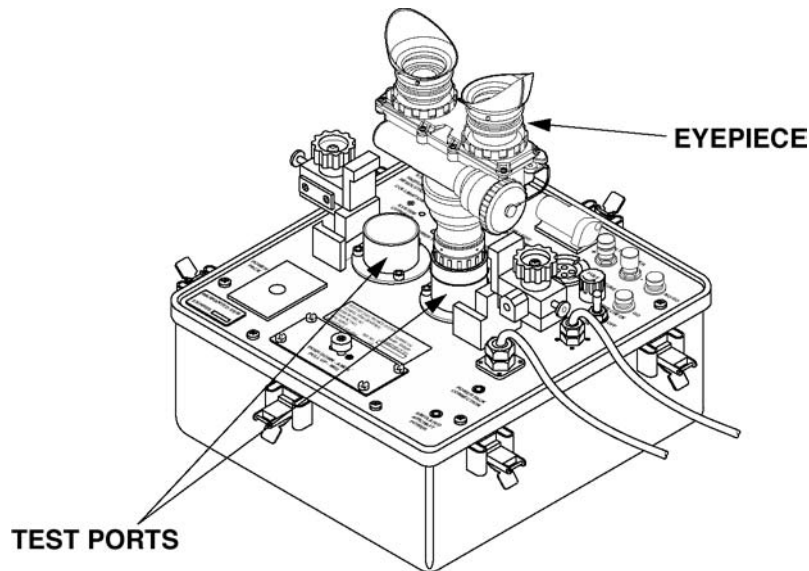

**Figure 3-1. Location of Major Components on the Test Set.**

- (6) Attach the goggles to the test set by inserting the objective lens into the adapter (Figure 3-2).



**3-9 TESTING THE NVG USING TS-3895A/UV -Continued**



**Figure 3-2. Inserting the Goggles into the Test Set.**

**LOW LIGHT RESOLUTION TEST**

**NOTE**

- The following test must be performed in a darkened area. Your eyes must be dark-adapted to perform this test. It takes a minimum of 10 minutes to become properly dark-adapted for low light resolution evaluation. However, if you have just been exposed to bright sunlight, dark adaptation will take longer.
- Do not reject goggles for resolution unless your eyes have been adequately dark-adapted.
- Review the following test procedure before entering the darkened area.

- (1) Turn the selector switch to the LOW LIGHT RESOLUTION (yellow) position (Figure 3-1).
- (2) Place the goggle switch in the down (ANVIS) position.
- (3) Turn off the room lights and let your eyes adjust to the dark.
- (4) Turn on the goggles and turn on the test set.

(5) Focus the objective lens and then the eyepiece lenses for best focus to obtain the sharpest image.

**3-9 TESTING THE NVG USING TS-3895A/UV -Continued**

(6) Look for flashing, flickering, instability, emission points, or edge glow, refer to (TM 11-5855-262-10-2). If any unacceptable conditions are noted, replace the image intensifier (para 3-14).

(7) Now observe the test pattern. You must be able to distinguish all three horizontal lines and all three vertical lines to count seeing the Element (Figure 3-3). You must be able to see Element 3 on the bottom of the test pattern for the NVG to pass.

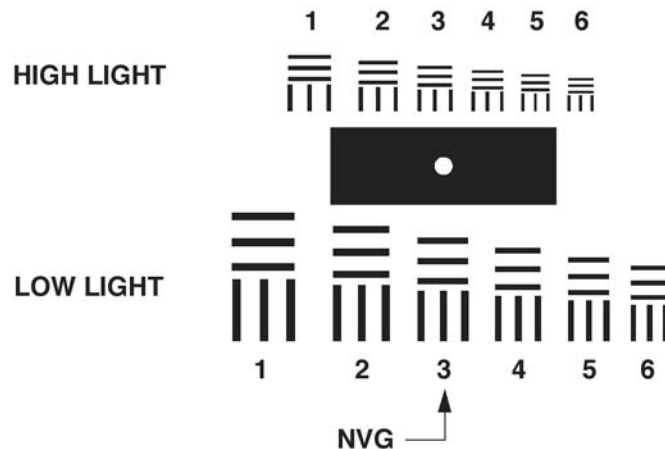

**Figure 3-3. Low Light Resolution Test Pattern.**

(8) If the goggles fail, recheck the objective and eyepiece focus to make sure you have the sharpest image.

(9) If the goggles still fail, refer to Table 3-1 Troubleshooting.

**HIGH LIGHT RESOLUTION TEST**

(1) Turn the selector switch to the HIGH LIGHT RESOLUTION (blue) position (Figure 3-1).

(2) Place the goggle switch in the down (ANVIS) position.

(3) Look for flashing, flickering, shading, or bright spots, refer to (TM 11-5855-262-10-2). If any unacceptable conditions are noted, replace the image intensifier (para 3-14).

(4) Now observe the test pattern. You must be able to distinguish all three horizontal lines and all three vertical lines to count seeing the Element (Figure 3-4). You must be able to see Element 3 on the top of the test pattern for the NVG to pass.

(5) If the goggles fail, recheck the objective lens and eyepiece lens focus to make sure you have the sharpest image.

(6) If the goggles still fail, refer to Table 3-1 Troubleshooting.

**3-9 TESTING THE NVG USING TS-3895A/UV -Continued**

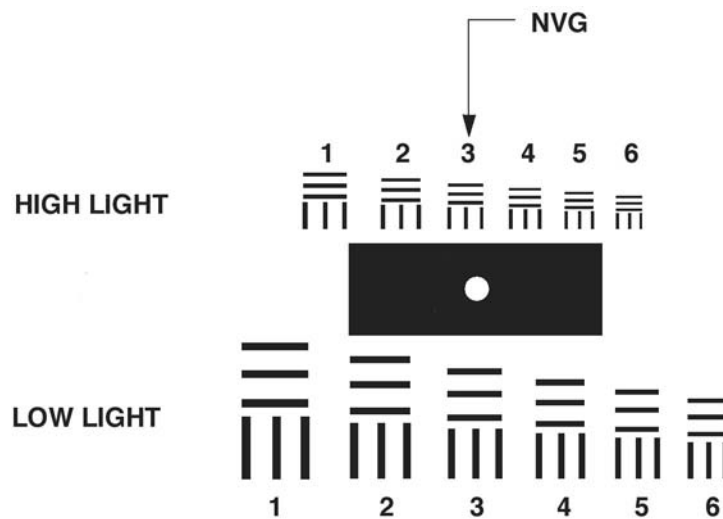

**Figure 3-4. High Light Resolution Test Pattern.**

**SHUTTING DOWN THE TS-3895A/UV TEST SET**

Refer to TM 11-5855-264-14, Operator's, Unit, Direct Support, and General Support Maintenance Manuals for TS-3895/UV and TS-3895A/UV Test Sets, to shut down the test set.

**3-10 ELECTRICAL TROUBLESHOOTING**

If image intensifier does not work after replacing batteries, with known good batteries, perform the following procedure to electrically troubleshoot the wired housing.

- (1) Remove image intensifier (para 3-14).
- (2) Set multimeter to measure 3 Vdc.
- (3) With known good batteries in battery compartments, position power switch to ON.
- (4) Apply test probes to the tube contact pins (Figure 3-5). The red test probe goes to positive (+) pin and black test probe goes to negative (-) pin.

**NOTE**

Perform voltage check within 70 ±30 seconds as high light cut-off circuit will activate in bright daylight or room light but not in fluorescent lighting. Set power switch to RESET/OFF position to reset goggles if high light cut-off occurs.

**3-10 ELECTRICAL TROUBLESHOOTING-Continued****NOTE**

Confirm the goggles or image intensifier is out of the warranty period before replacing the image intensifier (para 1-7).

(5) If 2.5 Vdc to 3.2 Vdc is present, replace image intensifier (para 3-14). If voltage is incorrect, remove and replace wired housing (para 3-16).

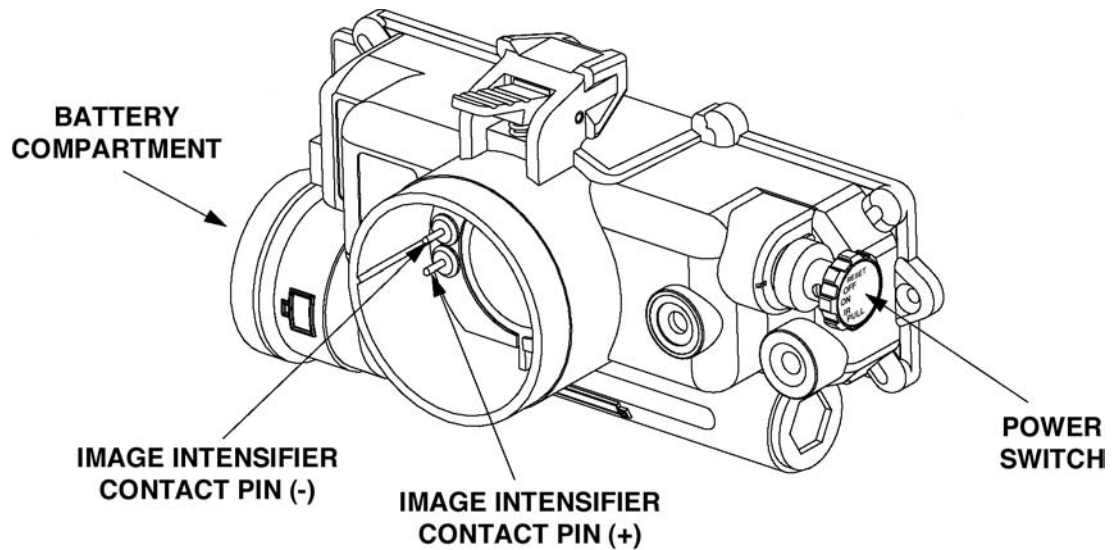

**Figure 3-5. Image Intensifier Contact Pin Location.**

### **3-11 BLACK SPOT CHECK**

Black spots are cosmetic blemishes and do not affect reliability. Generally, you can assume that the black spot was there during acceptance testing. However, occasionally the need may arise to verify the location, size, and number of spots. This test allows the maintainer to evaluate possible out-of-specification black spots, dark spots, or opaque spots in the image area against the specifications for the image intensifier.

---

#### **INITIAL SETUP**

##### Test Facility

Dark room

##### Tools

Measuring tape, (Appendix B, Item 13)  
3-volt incandescent flashlight or smaller, (Appendix B, Item 11)

##### Equipment

Black spot target (Appendix E, Item 1)  
Light source: LED on any other system such as AN/PVS-5X, or an AN/PVS-7X, or an IR light transmitter (Appendix B, Item 10)  
Tripod or fabricated Black Spot Target Test Fixture (Appendix E, Items 2-8)  
Dispenser, alcohol (Appendix D, Item 5)

##### Materials/Parts

Cotton-tipped applicators (Appendix D, Item 10)  
Isopropyl alcohol (Appendix D, Item 1)

#### **NOTE**

- The following test must be performed in a darkened area. Your eyes must be dark-adapted to perform this test. It takes approximately 10 minutes to become properly dark-adapted for low light resolution evaluation. However, if you have just been exposed to bright sunlight, dark adaptation will take longer.
  - Review the following test procedure before entering the darkened area.
  - You will need a flashlight filter, to read this procedure while in the darkened area.
-

**3-11 BLACK SPOT CHECK - Continued**

**LIGHTS ON**

- (1) Set up your dark room as shown in Figure 3-6 or Figure 3-7.

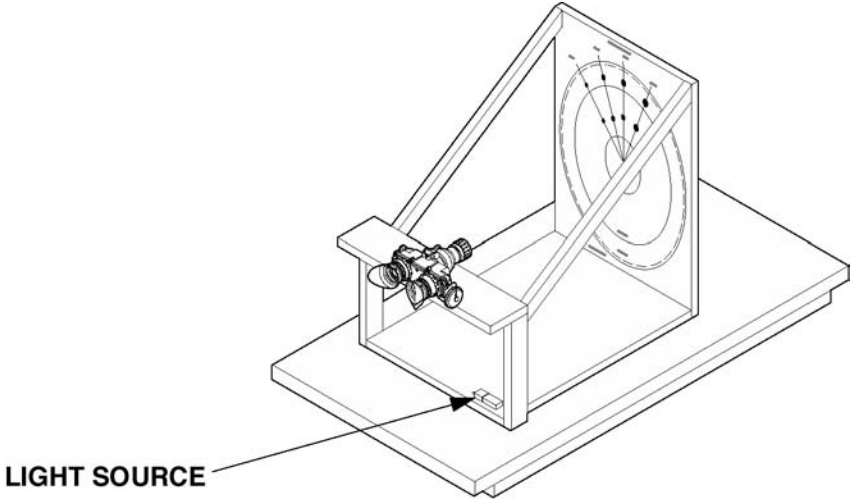

**Figure 3-6. Dark Room Setup with Test Fixture.**

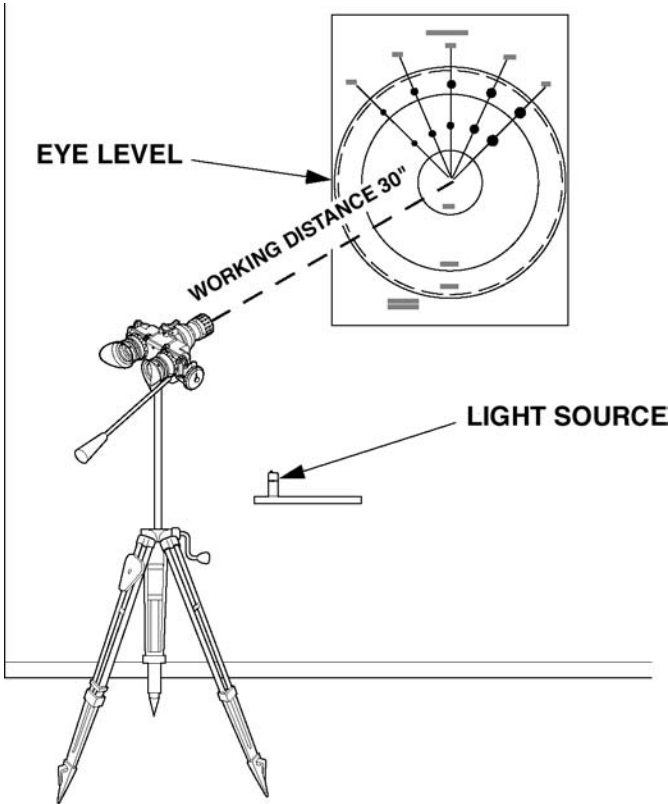

**Figure 3-7. Dark Room Setup with Tripod.**

**3-11 BLACK SPOT CHECK - Continued**

- (2) Position the Black Spot Chart so the center ring is at eye level during testing.
- (3) Clean the objective and eyepiece lenses of the systems to be tested by using isopropyl alcohol and cotton-tipped applicators. Moisten the applicator with the alcohol and use circular motions beginning at the center of the lens and moving in larger circles to the outside of the lens.
- (4) Position the goggles to be tested on the tripod or test fixture and secure it. The front surface of the objective lens of the goggles should be exactly 30 inches from the target at height of the center ring.
- (5) Position the light source behind, to the left, right, top, or bottom of the tripod to prevent shadows on the targets. Make sure that your position when looking through the goggles does not produce shadows on the target.

**LIGHTS OFF**

**NOTE**

The following test must be performed in a darkened area. Your eyes must be dark-adapted to perform this test. It takes approximately 10 minutes to become properly dark-adapted for low light resolution evaluation. However, if you have just been exposed to bright sunlight, dark adaptation will take longer.

- (1) Switch off the room lights.
- (2) Turn on the goggles.
- (3) Check the dark room for light leaks using another set of NVG (AN/PVS-5X or AN/PVS-7X) and eliminate any leaks you find. Follow good dark room techniques.
- (4) Turn on the light source and look through the goggles. Uniformly illuminate the target by moving the light source closer or farther from the target. Eliminate any shadows.
- (5) Alternately adjust the objective focus and diopter setting, **AT THE WORKING DISTANCE**, until the best focus is achieved. You must have the proper focus and the exact working distance of 30 inches from the front surface of the objective lens to achieve correct results.
- (6) Look at the edge of the spots in the center ring, and move the light source forward or back for the best spot contrast. Remember to refocus the objective each time you view a different ring of the chart.
- (7) Use the flashlight to recheck the exact position of the goggles at 30 inches ( $\pm 1$  inch). This distance from the target to the objective is critical and must be maintained during testing.

**TEST METHOD**

- (1) Center the view so it is concentric with the test target rings. (The dotted line represents a circle of 17.5 mm on the cathode surface of the image intensifier). Use the lines to the left and right of the outer circle to accomplish this.
- (2) Observe the image for black spots.

**3-11 BLACK SPOT CHECK - Continued**

**NOTE**

The total diameter of each image intensifier may vary between 17.5 mm and 18.5 mm. Evaluate only those black spots in the area of the image inside the 17.5 mm circle. The dotted line in the second ring marks this 17.5 mm area. Spots that are located outside the dotted circle are not a cause for rejecting the image intensifier.

- (3) Identify the ring of the chart that bounds the black spot you are evaluating.
- (4) Refocus the objective for the best focus on the ring of the chart identified above.
- (5) Using the allowable spot-size chart in that particular ring, determine the size of the black spot.

**NOTE**

Circular spots will correspond easily to this chart. However, irregular (non-circular) spots require you to judge the area of the spot in question against the area of the circular spot on the chart.

- (6) Count the number of spots, by spot size, in each ring and record these figures.

**PASS/FAIL CRITERIA**

- (1) Refer to Tables 3-2 and 3-3 for a listing of allowable spots and sizes to determine if the image intensifier under test should be rejected.

**Table 3-2. MX-10130B or C Allowable Black Spots and Sizes.**

SIZE AND LOCATION	.003 .006	.006 .009	.009 .012	.012 .015	LARGER THAN .015	SMALLER THAN .003
Center Ring	3	1	0	0	0	any amount
1st Ring	35	9	5	1	0	any amount
2nd Ring	35	23	8	2	0	any amount

**Table 3-3. MX-10130D Allowable Black Spots and Sizes.**

SIZE AND LOCATION	.003 .006	.006 .009	.009 .012	.012 .015	LARGER THAN .015	SMALLER THAN .003
Center Ring	0	0	0	0	0	any amount
1st Ring	2	1	0	0	0	any amount
2nd Ring	2	1	0	0	0	any amount



**3-11 BLACK SPOT CHECK - Continued**

(2) The image intensifier fails if the black spot (circular) is larger than the maximum spot size indicated on the chart for the ring in which the spot (circular) is located, or if the number of spots exceeds the number of spots allowed for that ring.

(3) The image intensifier fails if the maintenance person determines, by comparison, that the area of the non-circular spot is larger than the area of the largest circular spot designated in that ring. This will be a subjective evaluation so remember that these spots were evaluated before Government acceptance at the contractor's plant and passed. Judging the area is difficult. See Examples 1 and 2 of Figure 3-8. Do not reject an image intensifier for an irregularly shaped spot by its diameter alone.

(4) Consider two spots and the distance between them as one spot anytime that this distance between the two spots is less than the diameter of either spot. The image intensifier fails if this total dimension (diameter) is greater than the allowable spot size diameter for the ring in which the spots are located.

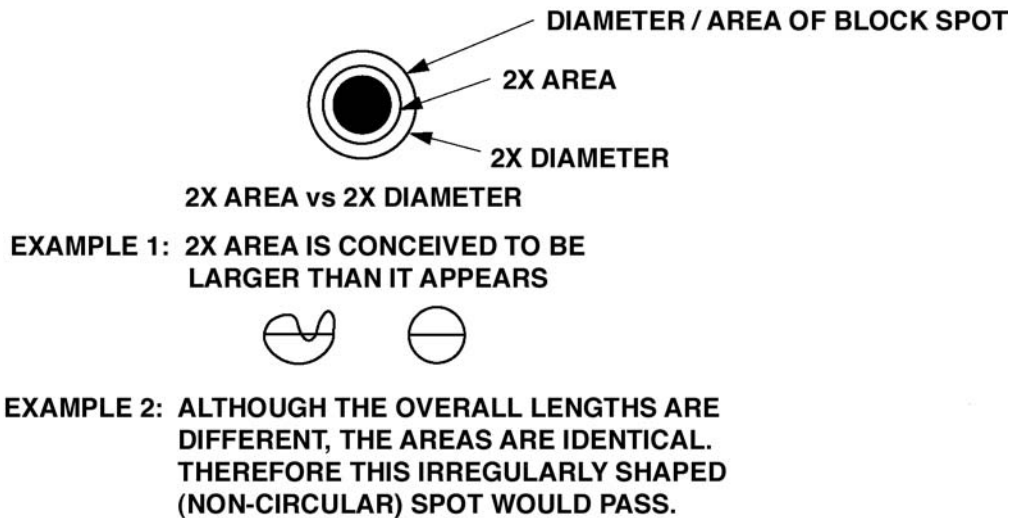

**Figure 3-8. Black Spot Evaluation.**

(5) A shaded area may surround a black spot. Consider the shaded area as part of the spot if the high light level resolution chart cannot be read through the shaded area (DS is to determine using the TS-3895A/UV). The image intensifier fails if the combined area of the spot and the shaded area exceed the maximum area of the largest spot for the ring in which the spot is located.

(6) Do not reject an image intensifier for a black spot that is located outside the dotted ring on the black spot chart.

**3-11 BLACK SPOT CHECK - Continued****NOTE**

If an image intensifier is rejected on the basis of this test for black spots, do not immediately reject the system for a defective image intensifier. It is possible that some of the spots may be caused by contamination inside the goggles and on the surfaces of the optics. You must disassemble the goggles and clean and inspect for dirt, debris, fingerprints, or other foreign material. Reassemble the goggles and recheck the image area for black spots.

**Section V. Maintenance Procedures.**

The following procedures detail the removal and installation of assemblies as authorized by the MAC located in Appendix B in this manual.

**3-12 REMOVAL AND INSTALLATION OF OBJECTIVE LENS**

The objective lens can be removed and installed without disturbing the image intensifier or wired housing. The airtight seal will be broken and the final assembly must be nitrogen purged to eliminate moisture within the goggles. The infinity focus may have to be adjusted when a new objective lens is installed (para 3-13).

**CAUTION**

To prevent damage to threads, do not use excessive force when re-threading the objective lens onto the wired housing.

**INITIAL SETUP**Test Facility

Clean station in the electronic service area

Tools

Slip joint pliers (Appendix B, Item 8)  
Dispenser, alcohol (Appendix D, Item 5)

### **3-12 REMOVAL AND INSTALLATION OF OBJECTIVE LENS - Continued**

#### Materials/Parts

- Objective lens (Appendix C, Fig. C-2 Item 1)
- O-ring (Appendix C, Fig. C-2 Item 2)
- Lubricant (silicone grease), (Appendix D, Item 2)
- Cotton-tipped applicators (Appendix D, Item 10)
- Isopropyl alcohol (Appendix D, Item 1)
- Sealing compound (Appendix D, Item 8)

---

#### **NOTE**

Confirm the NVG is out of the warranty period before replacing the objective lens (para 1-7).

#### **REMOVAL**

- (1) With objective lens (Figure 3-9) facing technician, rotate objective lens counterclockwise and remove lens from threaded part of wired housing. Be careful not to disturb location of image intensifier in wired housing.
- (2) Remove O-ring from inside large end of objective lens.

#### **INSTALLATION**

- (1) Thoroughly clean all optical surfaces with cotton-tipped applicators and isopropyl alcohol or compressed air. Mating surfaces should be cleaned with clean lint-free cloths and isopropyl alcohol before assembly. If damaged, replace with new objective lens (Figure 3-9).
- (2) Apply a light coating of lubricant on O-ring before inserting into groove in objective lens.

#### **CAUTION**

Be careful not to spread lubricant on optical surfaces, which will be difficult to reclean.

- (3) Carefully thread objective lens clockwise onto wired housing. Ensure that image intensifier is properly in place. Do not tighten.
- (4) Purge goggles (para 3-18).
- (5) Tighten objective lens to snug O-ring onto wired housing.

**3-12 REMOVAL AND INSTALLATION OF OBJECTIVE LENS - Continued**

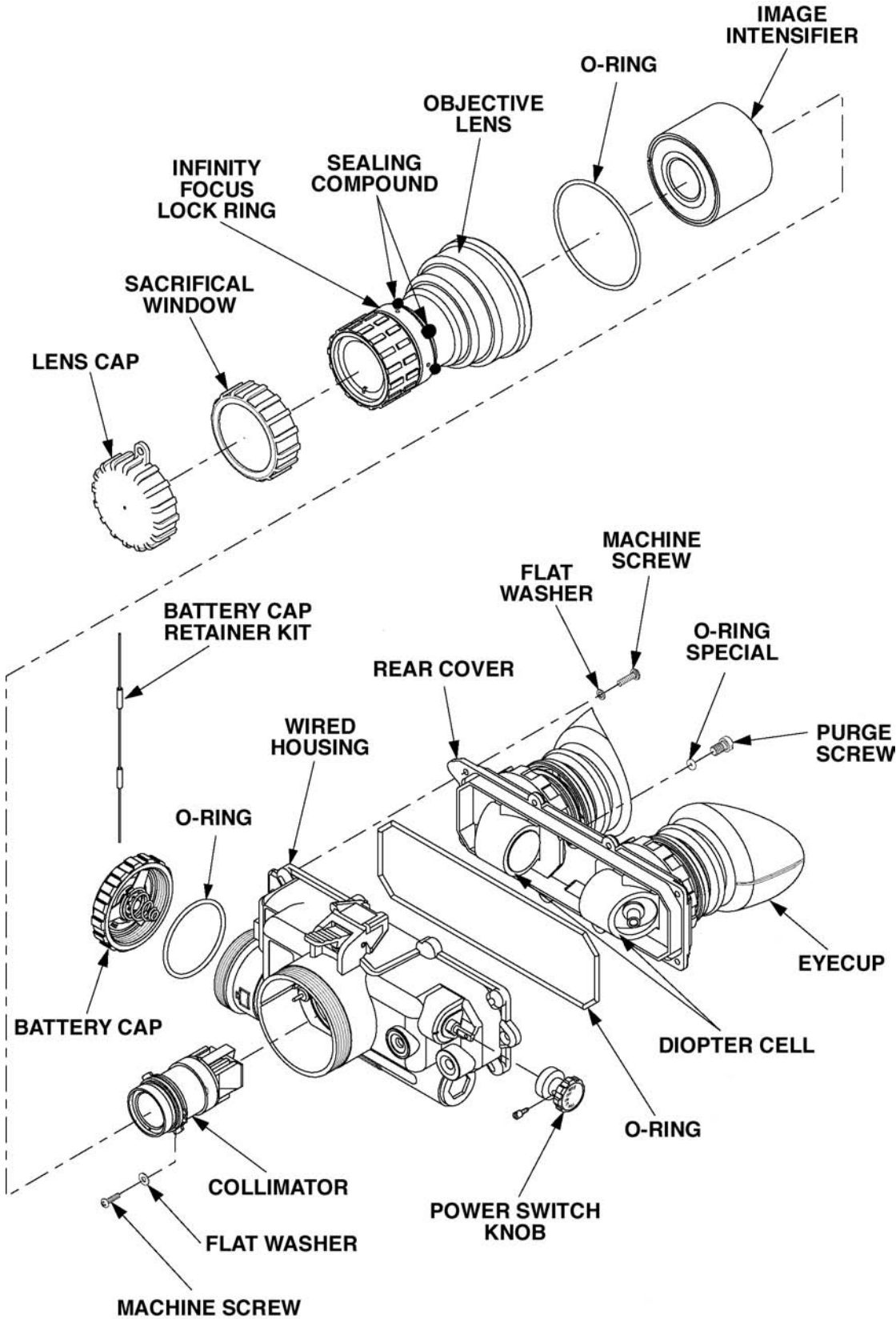

Figure 3-9. Goggles Assembly/Disassembly.

### **3-13 OBJECTIVE LENS INFINITY FOCUS ADJUSTMENT**

The infinity focus stop may have to be adjusted when a new objective lens or the image intensifier is installed on the goggles. Perform the following procedure to set the infinity focus stop.

- (1) Ensure that objective lens has been installed (para 3-12) and that the goggles have been purged (para 3-18).
- (2) Perform Initial Setup, Procedure, and low light resolution test (para 3-9).
- (3) Focus each diopter adjustment for best focus in each eyepiece.
- (4) With the objective lens facing away from the operator, rotate objective lens fully clockwise. Using a pair of slip-joint pliers (Appendix B, Item 8), loosen infinity focus lock ring (Figure 3-9) by turning lock ring fully counterclockwise. Using a cotton-tipped applicator moistened with isopropyl alcohol, clean away excess sealing compound. If necessary, rotate objective lens lock ring back and forth to help clean out the threads.
- (5) Focus the objective lens by rotating objective focus ring counterclockwise slightly past best focus (image begins to blur) of the resolution pattern shown in Figure 3-3.
- (6) Maintain objective focus setting and use your fingers to rotate infinity focus lock ring (Figure 3-11) clockwise until ring just contacts the objective focus knob.

#### **CAUTION**

Applying too much sealing compound, will damage parts.

- (7) Apply one drop of sealing compound (Appendix D, Item 8) on threads at rear of infinity focus lock ring 90 degrees apart (Figure 3-9). Allow 10 minutes for sealing compound to cure.

### **3-14 REMOVAL AND INSTALLATION OF IMAGE INTENSIFIER**

The image intensifier can be removed and installed without performing any disassembly of the wired housing. It requires only removing the objective lens. The airtight seal will be broken and the final assembly must be nitrogen purged to eliminate moisture within the goggles. The infinity focus stop may have to be adjusted when a new image intensifier or new objective lens is installed on the goggles (para 3-13).

---

#### **INITIAL SETUP**

Test Facility

Clean station in the electronic repair service area

Tools

None

**3-14 REMOVAL AND INSTALLATION OF IMAGE INTENSIFIER - Continued**Materials/Parts

Image intensifier (Appendix C, Figure C-2, Item 3)  
Cotton-tipped applicators (Appendix D, Item 10)  
Isopropyl alcohol (Appendix D, Item 1)

---

**WARNING****Toxic Material**

The image intensifier's phosphor screen contains toxic materials.

- If an image intensifier breaks, be extremely careful to avoid inhaling the phosphor screen material. Do not allow the material to come in contact with the mouth or open wounds on the skin.
- If the phosphor screen material contacts your skin, wash it off immediately with soap and water.
- If you inhale/swallow any phosphor screen material, drink a lot of water, induce vomiting, and seek medical attention as soon as possible.

**NOTE**

Confirm the image intensifier is out of the warranty period before replacing the image intensifier. If in the warranty period (para 1-7). If not in the warranty period (para 3-21).

**REMOVAL**

- (1) Remove objective lens (para 3-12).

**CAUTION**

Handle image intensifier gently to prevent damage. Set image intensifier only on contact end. Treat suspected defective image intensifiers as though they are good so they are not damaged when returned to Defense Reutilization and Marketing Office (DRMO).

- (2) Gently ease out image intensifier from within wired body housing. Pull out straight forward from housing.

- (3) If image intensifier is not defective, wrap in lens paper to protect and store in a clean dry place.

**INSTALLATION**

- (1) If image intensifier is defective, replace with a new image intensifier.

### **3-14 REMOVAL AND INSTALLATION OF IMAGE INTENSIFIER - Continued**

#### **CAUTION**

- Use care when opening shipping container to prevent damage.
- Treat defective image intensifier carefully so it can be returned to DRMO undamaged.
- Do not force the image intensifier into the wired housing.

#### **NOTE**

Retain packaging material for use when returning defective image intensifiers to DRMO.

(2) Clean both ends of image intensifier with cotton-tipped applicators and isopropyl alcohol.

(3) Slide the image intensifier (Figure 3-9), contacts end first, into the opening of the wired housing so the groove on the side of the image intensifier engages the ridge inside the opening of the wired housing.

(4) Install the objective lens.(para 3-12).

(5) Purge the goggles (para 3-18).

### **3-15 REMOVAL AND INSTALLATION OF COLLIMATOR**

The collimator can be removed and installed without disassembling the wired housing from the rear cover. The airtight seal will be broken and after the final reassembly must be purged to eliminate moisture within the goggles. The infinity focus stop may have to be adjusted when a new collimator is installed in the goggles (para 3-13).

---

### **INITIAL SETUP**

#### Test Facility

Clean station in the electronic repair service area

#### Tools

Screwdriver, cross-tipped, (Appendix B, Item 11)  
Jeweler's file  
Dispenser, alcohol (Appendix D, Item 5)

**3-15 REMOVAL AND INSTALLATION OF COLLIMATOR - Continued**Materials/Parts

Collimator (Appendix C, Figure C-2, Item 15)  
Tape, black, 1/2-inch, (Appendix B, Item 11)  
Cotton-tipped applicators (Appendix D, Item 10)  
Isopropyl alcohol (Appendix D, Item 1)

---

**NOTE**

Confirm the goggles are out of the warranty period before replacing the collimator (para 1-7).

**REMOVAL**

- (1) Remove objective lens (para 3-12).
- (2) Remove image intensifier (para 3-14). Store in clean dry place if not damaged.

**CAUTION**

To prevent damage to collimator during removal, set eyepiece interpupillary distance to maximum.

- (3) With front of wired housing (Figure 3-9) facing you, remove two screws and two washers which secure the collimator in the wired housing.
- (4) Carefully remove the collimator from the wired housing. If the collimator is not defective, store in a clean dry place.

**INSTALLATION****NOTE**

To complete the collimator installation, you will need to make a straight black line on the wall or a light-colored piece of wood or cardboard. Place a 2-foot strip of 1/2-inch black tape horizontally across the center of the board or on the wall about 2 to 4 inches above table height. Make sure the taped line is straight.

- (1) If collimator is defective, replace with a new assembly.

**CAUTION**

To prevent damage to eyepieces during installation, set eyepiece interpupillary distance to maximum.



**3-15 REMOVAL AND INSTALLATION OF COLLIMATOR - Continued**

(2) Remove the eyecups (Figure 3-9) from the eyepieces.

(3) Looking at the eyepiece end of the wired housing, turn the diopter focus rings fully counterclockwise so the eyepieces are extended all the way out.

(4) Place the collimator, prism end first, into the opening of the wired housing. Align the raised notch of the wired housing with the slot on the side of collimator (Figure 3-10).

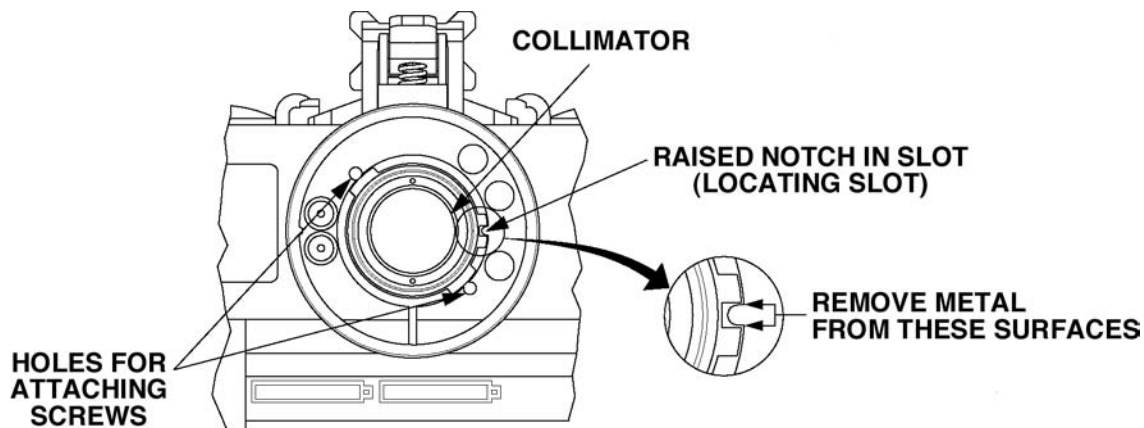

**Figure 3-10. Installing the Collimator.**

(5) Insert the two attaching screws (Figure 3-9) and two washers. Screw them in all the way but do not tighten them, leave them loose enough to allow the collimator to move slightly.

**NOTE**

The collimator will only move a very small amount.

(6) Position a table or bench so one end is 58 inches from the collimation line. The line should be within 4 inches of the height of the tabletop. Make sure the tabletop is parallel to the line. As shown in Figure 3-11, rest the eyepiece flanges on end of the tabletop so the diopter adjust rings butt against the vertical edge.

**3-15 REMOVAL AND INSTALLATION OF COLLIMATOR - Continued**

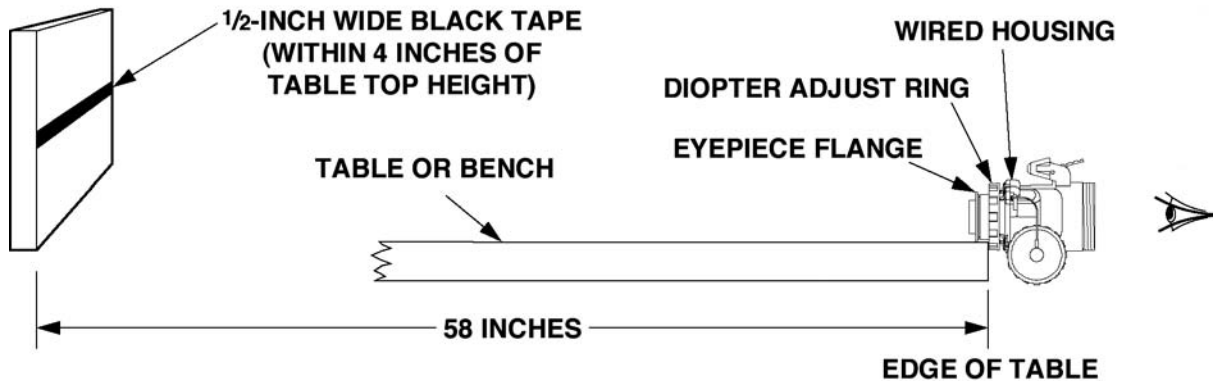

**Figure 3-11. Setting Up the Wired Housing to View the Line.**

(7) Keeping the wired housing level, aim the eyepieces at the black line and look into the opening of the wired housing and at the split image formed by the collimator. Make sure you can see the black line clearly; your eyes will need to be about 10 to 20 inches away from the collimator. Keep the line centered in the field-of-view and the split in the middle of the collimator's image (Figure 3-12).

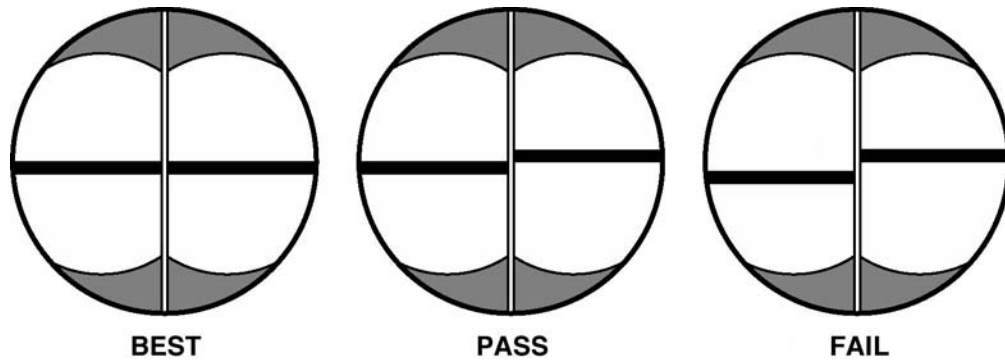

**Figure 3-12. Aligning the Split Image of the Collimation Line.**

(8) While looking at the image, carefully rotate the collimator until the black line in the left side aligns with the black line in the right side (Figure 3-12). If the collimator cannot be turned to adjust collimation, remove the two retaining screws and carefully remove the collimator. Using the jeweler's file, widen the locating slot by removing a small amount of metal from each side (Figure 3-10). The slot only needs to be widened a few thousandths of an inch. Install the collimator per steps 4 and 5 and set collimation per steps 6-9.

(9) When the image is aligned, hold the collimator in place so it does not move (be careful not to touch the optics) and tighten the two attaching screws. Do not over tighten the screws. Recheck the alignment of the left and right image to make sure the collimator did not move.

(10) Inspect the collimator for fingerprints or dirt. If necessary, clean the optics with a cotton-tipped applicator and isopropyl alcohol.

(11) Install the image intensifier. (para 3-14).

### **3-15 REMOVAL AND INSTALLATION OF COLLIMATOR - Continued**

(12) Install the objective lens (para 3-12).

(13) Purge the goggles (para 3-18).

### **3-16 REMOVAL AND INSTALLATION OF WIRED HOUSING**

The wired housing (Figure 3-9) can be removed and installed by removing the objective lens, the image intensifier and the collimator. Eight screws secure the rear cover to the back of the wired housing. The airtight seal will be broken and the final assembly must be purged to eliminate moisture within the goggles. The infinity focus stop may have to be adjusted when a new wired housing is installed (para 3-13).

---

### **INITIAL SETUP**

#### Test Facility

Clean station in the electronic repair service area

#### Tools

Screwdriver, cross-tipped (Appendix B, Item 11)  
Dispenser, alcohol (Appendix D, Item 5)

#### Materials/Parts

Wired Housing (Appendix C, Figure C-2, Item 13)  
O-ring (Appendix C, Figure C-2, Item 10)  
Lubricant (silicone grease), (Appendix D, Item 2)  
Cotton-tipped applicators (Appendix D, Item 10)  
Isopropyl alcohol (Appendix D, Item 1)

---

### **NOTE**

Confirm the goggles are out of the warranty period before replacing the wired housing (para 1-7).

### **REMOVAL**

(1) Remove objective lens (para 3-12).

(2) Remove image intensifier (para 3-14). Store in clean dry place if not defective.

### **CAUTION**

To prevent damage to eyepiece, during rear cover removal, set eyepiece interpupillary distance to maximum.

**3-16 REMOVAL AND INSTALLATION OF WIRED HOUSING - Continued**

- (3) Remove collimator (para 3-15). Store in a clean dry place.
- (4) Remove the eight screws (Figure 3-9) and washers that secure the rear cover to the wired housing.

**CAUTION**

To prevent damage to flex harness inside wired housing, gently separate the rear cover from the wired housing.

- (5) Carefully remove the two LED assemblies from the diopter cell assemblies, freeing rear cover from wired housing and its flex harness.
- (6) Remove O-ring from around rear cover. Remove battery cap and battery cap retainer link (para 2-12) from the wired housing.
- (7) Inspect O-ring for nicks, cuts, or cracks, Replace if defective.
- (8) Remove neck cord and objective lens cap(para 2-11).
- (9) Store wired housing, rear cover, O-ring, battery cap, battery cap retainer link, neck cord, and objective lens cap in clean dry place.

**INSTALLATION**

- (1) If wired housing is defective, replace with a new assembly.
- (2) Apply a light coating of lubricant ( Appendix D, Item 2); to the O-ring (Figure 3-9) and install in groove around rear cover.

**CAUTION**

To prevent damage to eyepiece during cover installation, set eyepiece interpupillary distance to maximum.

- (3) Clean diopter cell assemblies with cotton-tipped applicators and isopropyl alcohol if necessary, carefully install the LED assemblies on flex harness into each diopter cell and the battery cap and battery cap's retainer kit on securing pin on wired housing.

**CAUTION**

Make sure the O-ring is completely in its groove or it will be pinched and damaged when rear cover is installed on wired housing.

- (4) Close rear cover against wired housing.
- (5) Install eight screws and eight washers that secure rear cover to wired housing. Check for pinching of O-ring before tightening and securing screws.
- (6) Install collimator (para 3-15).

### **3-16 REMOVAL AND INSTALLATION OF WIRED HOUSING - Continued**

- (7) Reinstall image intensifier (para 3-14).
- (8) Reinstall objective lens (para 3-12).
- (9) Purge goggles (para 3-18).
- (10) Reinstall the neck cord and objective lens cap (para 2-11).
- (11) Reinstall the battery cap and battery cap retaining link (para 2-12).

#### **NOTE**

Be sure that the data plate is removed from the old wired housing and placed on the new assembly.

### **3-17 REMOVAL AND INSTALLATION OF REAR COVER**

The rear cover can be removed and installed without disturbing the front assemblies unless damaged. Eight screws secure the rear cover to the wired housing. If the rear cover is removed, the goggles must be purged to eliminate moisture inside.

---

### **INITIAL SETUP**

#### Test Facility

Clean station in the electronic repair service area

#### Tools

Screwdriver, cross-tipped (Appendix B, Item 11)  
Dispenser, alcohol (Appendix D, Item 5)

#### Materials/Parts

Rear Cover (Appendix C, Figure C-2, Item 9)  
O-ring (Appendix C, Figure C-2, Item 10)  
Lubricant (silicone grease), (Appendix D, Item 2)  
Cotton-tipped applicators (Appendix D, Item 10)  
Isopropyl alcohol (Appendix D, Item 1)

---

#### **NOTE**

Confirm the goggles are out of the warranty period before replacing the rear cover (para 1-7).

### **REMOVAL**

- (1) With the eyepieces facing you, gently remove eyecups (Figure 3-9) from rear cover.

**3-17 REMOVAL AND INSTALLATION OF REAR COVER - Continued****CAUTION**

To prevent damage to collimator during rear cover removal, set eyepiece interpupillary distance to maximum.

- (2) Remove eight screws and eight washers that secure rear cover to wired housing.

**CAUTION**

The wired housing is attached to the rear cover. To prevent damage to flex harness inside wired housing, gently separate rear cover from the wired housing.

- (3) Carefully remove the two LED assemblies from the diopter cell assemblies, freeing rear cover from wired housing and flex harness.

- (4) Remove O-ring from rear cover. Remove the battery cap and battery cap retainer (para 2-12) after separating the rear cover from the wired housing.

**INSTALLATION****CAUTION**

To prevent damage to the collimator during assembly, set eyepiece interpupillary distance to maximum.

- (1) Apply a light coating of lubricant on O-ring (Figure 3-9) before inserting it into groove in rear cover and if necessary apply a light coating of lubricant to the inside back cover of the rear cover.

**CAUTION**

Be careful not to spread lubricant on optical surfaces, which will be difficult to reclean.

- (2) Clean diopter cell and collimator assemblies with cotton-tipped applicators and isopropyl alcohol or compressed air as necessary.

- (3) Carefully install LED assemblies on flex harness into each diopter cell. Reinstall battery cap and battery cap retainer before closing rear cover against wired housing.

- (4) Install eight screws and eight washers which secure rear cover to wired housing. Check for pinching of O-ring before tightening securing screws.

- (5) With eyepieces facing you, gently push the eyecups on the eyepieces.

- (6) Purge goggles (para 3-18).

**3-18 PURGING**

The housing of the NVG (Figure 3-9) is filled with dry nitrogen and sealed to prevent dirt and moisture from degrading the optical performance during use. Perform the following procedure to purge the goggles.

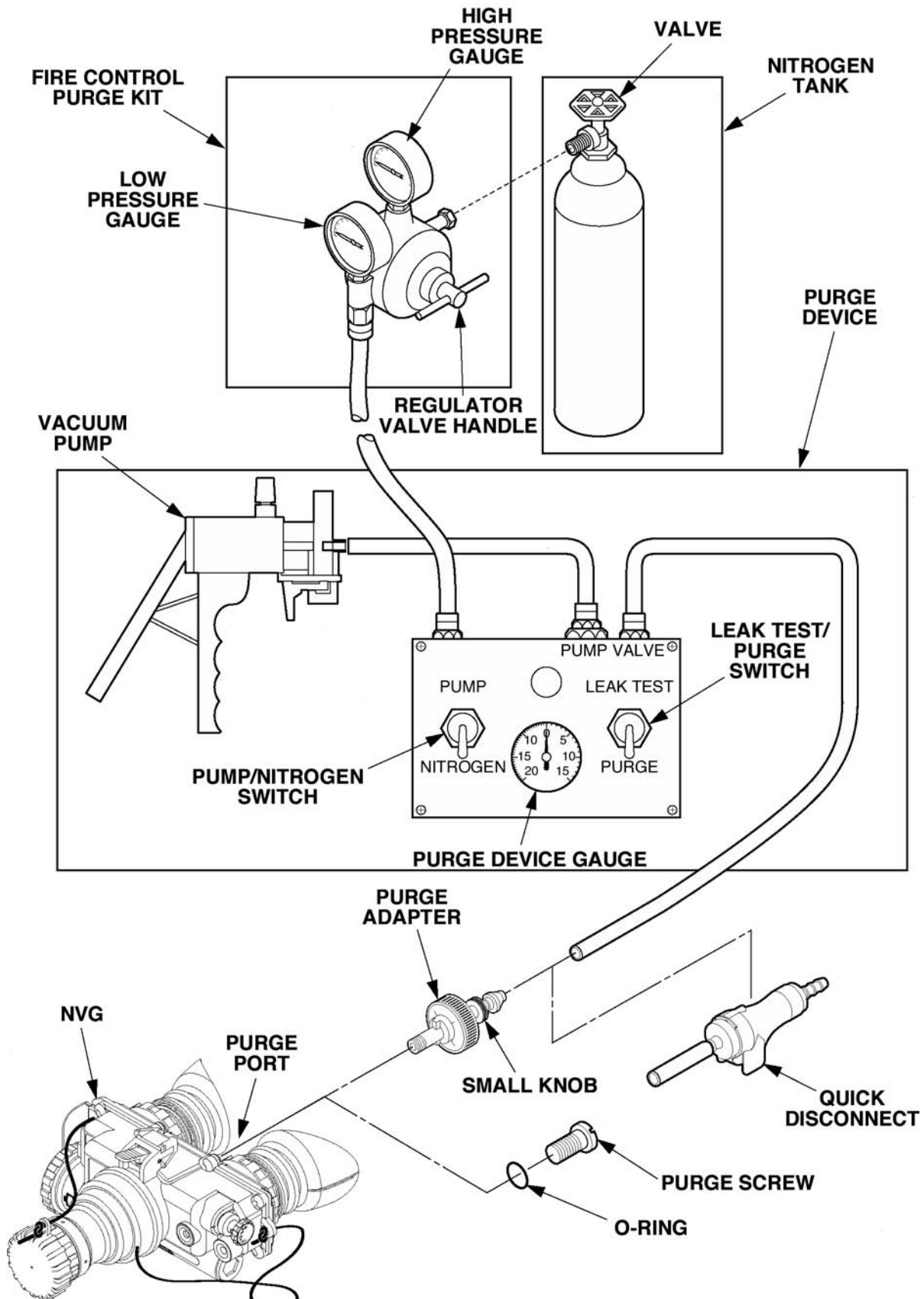

Figure 3-13. Nitrogen Purging Equipment Setup.

**3-18 PURGING - Continued****INITIAL SETUP**Test Facility

Clean station in the electronic repair service area

Tools

Screwdriver, flat tipped (Appendix B, Item 11)

Wrench (Appendix B, Item 12)

Equipment

Purge device (Appendix B, Item 5), or commercial equivalent

Fire Control Purging Kit (Appendix B, Item 9)

Purge Adapter (Appendix B, Item 7), or commercial equivalent

Quick Disconnect (optional, commercially available)

Materials/Parts

Nitrogen, Compression type: water pumped

Composition and percentage: 99.5% nitrogen by volume (Appendix D, Item 4),  
or commercial equivalent

O-ring (Appendix C, Figure C-2, Item 8)

Lubricant (silicone grease), (Appendix D, Item 2)

References

TM 750-116, General Procedures for Purging and Charging of Fire Control Instruments

---

**WARNING****Personnel Injury**

- Serious injury may result if the nitrogen tank valve breaks off due to tank upset. If the tank valve breaks, the tank can be propelled by the escaping gas and strike you or others.
- Always secure the tank to an upright support before removing the tank valve guard and attaching the regulator valve to the tank.



**3-18 PURGING – Continued**

- (1) Connect fire control purging kit, using a wrench , or equivalent, to nitrogen tank and purge device as shown in Figure 3-13 and in accordance with TM 750-116.
- (2) Ensure that valve is closed on the nitrogen tank.
- (3) Set regular valve handle for zero psi by rotating control until there is no spring pressure on control.
- (4) Remove purge screw and O-ring from the purge port of the goggles.

**CAUTION**

Do not over tighten purge adapter to prevent damage to O-ring seat.

- (5) Thread purge adapter approximately three turns into the purge port of the goggles.
- (6) Attach hose of purge device to quick disconnect, if present, and into purge adapter.
- (7) Open nitrogen tank valve. The high pressure gauge will indicate tank pressure. If the pressure is below 100 pounds, replace tank.
- (8) Set purge device PUMP/NITROGEN switch to PUMP and the LEAK TEST/PURGE switch to PURGE.
- (9) Slowly adjust regulator valve handle by turning it clockwise until low-pressure gauge indicates 3 to 3.5 psi.
- (10) Pump vacuum handle of the purge device until purge device gauge indicates greater than 15 in. Hg (Mercury).
- (11) Purge goggles by positioning purge device PUMP/NITROGEN switch to NITROGEN and observe that the purge device gauge indicates 3 to 3.5 psi. If necessary, slowly adjust regulator valve handle until purge device gauge reaches 3 to 3.5 psi.
- (12) Repeat steps 8, 10, and 11 one additional time.
- (13) Turn PUMP/NITROGEN switch to PUMP.

### **3-18 PURGING - Continued**

- (14) Set regulator valve handle for zero.
- (15) Turn off nitrogen tank valve.

#### **NOTE**

Purging the goggles is not intended to result in a positive pressure inside the housing. Consequently, it is okay to leave the purge port open briefly after removing the purge adapter and purge device hose and before installing the O-ring and purge screw.

- (16) Remove hose (using quick disconnect), then remove purge adapter from the purge port.
- (17) Inspect O-ring for signs of damage. Replace, if required. Lubricate O-ring with lubricant and install with the purge screw into the purge port of the goggles.

### **3-19 OPERATIONAL CHECKS**

Perform the following operational checks after removing and replacing or installing any assemblies of the goggles.

- (1) Perform low light and high light resolution tests (para 3-9).
- (2) Perform operational checks (TM 11-5855-262-10-2).

## **Section VI. Preparation for Storage and Shipment.**

### **3-20 PACKING THE NVG**

Packing procedures for the NVG are the same as that for unit maintenance (para 2-21).

### **3-21 SHIPPING THE IMAGE INTENSIFIER**

If an image intensifier has been replaced and it is still under warranty, refer to paragraph 1-7 for instructions.

Whenever an image intensifier has been replaced, pack the removed image intensifier in the packing and shipping material in which you received the new image intensifier or use equivalent packing material. The original packing and shipping material provides the appropriate protection for the image intensifier.

If the removed image intensifier is out of warranty, turn in the removed image intensifier along with a completed copy of DRMS Form 1930, Hazardous Waste Profile Sheet, into your local DRMO for disposal.

## APPENDIX A REFERENCES

---

### A-1 SCOPE

This appendix lists all the forms, field manuals, technical manuals, and miscellaneous publications applicable to this manual.

### A-2 FORMS

Hazardous Waste Profile Sheet .....	DRMS 1930
Inspection and Maintenance Record .....	DA 2404
Maintenance Request .....	DA 2407
Product Quality Deficiency Report .....	SF 368
Recommended Changes to Equipment Technical Publications .....	DA 2028-2
Recommended Changes to Technical Publications .....	NAVMC 10772
Recommended Changes to Publications and Blank Forms .....	DA 2028
Report of Discrepancy .....	SF 364
Requisition and Invoice/Shipping Document .....	DD 1149

### A-3 FIELD MANUALS

First Aid for Soldiers .....	FM 21-11
------------------------------	----------

### A-4 TECHNICAL MANUALS

Equipment Record Procedures .....	TM 4700-15/1
General Procedures for Purging and Charging of Fire Control Instruments .....	TM 750-116
Operator's and Unit Maintenance Manual (including Repair Parts and Special Tools List) for the Test Set, Electronic Systems Test Set TS-4348/UV .....	TM 11-5855-299-12&P
Operator's, Aviation Unit, Direct Support, and General Support Maintenance Manual for TS-3895/UV and TS-3895A/UV Test Sets .....	TM 11-5855-264-14
Operator's Manual for Night Vision Goggles (NVG), AN/PVS-7B and AN/PVS-7D Procedures for the Destruction of Electronic Materiel to Prevent Enemy Use (Electronics Command) .....	TM 11-5855-262-10-2 TM 750-244-2

### A-5 MISCELLANEOUS PUBLICATIONS

Army Medical Department Expendable/Durable Items .....	CTA 8-100
Battery Disposition/Disposal Handbook .....	TB 43-0134
Consolidated Index of Army Publications and Blank Forms .....	DA Pam 25-30
Expendable/Durable Items (Except Medical, Class V, Repair Parts, and Heraldic Items) .....	CTA 50-970
Instructions for the Safe Handling and Identification of U.S. Army Communications—Electronics Command Managed Lithium Sulphur Dioxide Batteries .....	TB 43-0130
The Army Maintenance Management System .....	DA Pam 738-750

## **TM 11-5855-262-23&P-2**

### **A-6 MARINE CORPS USE**

Equipment Record Procedures.....	TM 4700-15/1
Marine Corps Publication Distribution System .....	MCPDS
Recommended Changes to Publications/Logistics-Maintenance Data Coding .....	NAVMC 10772
Transportation and Travel Record of Transportation Discrepancies .....	MCO P4610.19
Quality Deficiency Report.....	MCO 4855.10

### **A-7 AIR FORCE USE**

General Shop Practice Requirement .....	00-25-234
Maintenance and Recoverability Coding .....	00-25-195
Quality Deficiency Report.....	00-35D-34

## APPENDIX B MAINTENANCE ALLOCATION CHART (MAC) (ARMY ONLY)

---

### Section I. Introduction.

#### **B-1 THE ARMY MAINTENANCE SYSTEM, MAC**

a. This introduction (Section I) provides a general explanation of all maintenance and repair functions authorized at various maintenance levels under the standard Army Maintenance System concept.

b. The MAC in Section II designates overall authority and responsibility for the performance of maintenance functions on the identified end item or component. The application of the maintenance functions to the end item or component will be consistent with the capacities and capabilities of the designated maintenance levels, which are shown on the MAC in column (4) as:

Unit — includes two subcolumns, C (operator/crew) and O (unit) maintenance.

Direct Support — includes an F subcolumn.

General Support — includes an H subcolumn.

Depot — includes a D subcolumn.

c. Section III lists the tools and test equipment (both special tools and common tool sets) required for each maintenance function as referenced from Section II.

d. Section IV contains supplemental instructions and explanatory notes for a particular maintenance function.

#### **B-2 MAINTENANCE FUNCTIONS**

Maintenance functions are limited to and defined as follows:

a. **Inspect.** To determine the serviceability of an item by comparing its physical, mechanical, and/or electrical characteristics with established standards through examination (e.g. by sight, sound, or feel).

b. **Test.** To verify serviceability by measuring the mechanical, pneumatic, hydraulic, or electrical characteristics of an item and comparing those characteristics with prescribed standard.

c. **Service.** Operations required periodically to keep an item in proper operating condition; i.e., to clean (includes decontaminate, when required), to preserve, to drain, to paint, or to replenish fuel, lubricants, chemical fluids, or gases.

d. **Adjust.** To maintain or regulate, within prescribed limits, by bringing into proper position, or by setting the operating characteristics to the specified parameters.

e. **Align.** To adjust specified variable elements of an item to bring about optimum or desired performance.

f. **Calibrate.** To determine and cause corrections to be made or to be adjusted on instruments or test, measuring and diagnostic equipment used in precision measurements. This consists of comparisons of two instruments, one of which is a certified standard of known accuracy, to detect and adjust any discrepancy in the accuracy being compared.

## TM 11-5855-262-23&P-2

g. Remove/Install. To remove and install the same item when required to perform service or other maintenance functions. Install may be the act of emplacing, seating or fixing into position a spare, repair part, or module (component or assembly) in a manner to allow the proper functioning of the equipment or system.

h. Replace. To remove an unserviceable item and install a serviceable counterpart in its place. "Replace" is authorized by the MAC and assigned maintenance level is shown as the 3d position of the SMR code.

i. Repair. The application of maintenance services<sup>1</sup> including fault location/ troubleshooting<sup>2</sup>, removal/installation, and disassembly/assembly<sup>3</sup> procedures, and maintenance actions<sup>4</sup> to identify troubles and restore serviceability to an item by correcting specific damage, fault, malfunction, or failure in a part, subassembly, module (component or assembly), end item, or system.

j. Overhaul. That maintenance effort (service/action) prescribed to restore an item to a completely serviceable/operational condition as required by maintenance standards in appropriate technical publications (i.e. DMWR). Overhaul is normally the highest degree of maintenance performed by the Army. Overhaul does not normally return an item to like new conditions.

k. Rebuild. Consists of those services/actions necessary for the restoration of unserviceable equipment to a like-new condition in accordance with original manufacturing standards. Rebuild is the highest degree of material maintenance applied to Army equipment. The rebuild operation includes the act of returning to zero those age measurements (hours, miles, etc.) considered in classifying Army equipment/components.

### B-3 EXPLANATION OF COLUMNS IN THE MAC, SECTION II

a. Column 1, Group Number. Column 1 lists the functional group code numbers, the purpose of which is to identify maintenance-significant components, assemblies, subassemblies, and modules with the next higher assembly.

b. Column 2, Component/Assembly. Column 2 contains the item names of components, assemblies, subassemblies, and modules for which maintenance is authorized.

c. Column 3, Maintenance Function. Column 3 lists the functions to be performed on the item listed in Column 2. (For detailed explanations of these functions, see para B-2).

d. Column 4, Maintenance Level. Column 4 specifies each level of maintenance authorized to perform the function listed in Column 3, by indicating work time required (expressed as man-hours in whole hours or decimals) in the appropriate subcolumn.

---

<sup>1</sup>Services — Inspect, test, service, adjust, align, calibrate, and/or replace.

<sup>2</sup>Fault locate/troubleshoot — The process of investigating and detecting the cause of equipment malfunctioning; the act of isolating a fault within a system or unit under test.

<sup>3</sup>Disassemble/assemble — Encompasses the step-by-step taking apart (or breakdown) of a spare/functional group coded item to the level of its least component identified as maintenance significant (i.e., assigned an SMR code) for the level of maintenance under consideration.

<sup>4</sup>Actions — Welding, grinding, riveting, straightening, facing, machining, and/or resurfacing.

This work-time figure represents the active time required to perform that maintenance function at the indicated level of maintenance. If the number or complexity of the tasks within the listed maintenance function vary at different maintenance levels, appropriate work-time figures will be shown for each level. The work-time figure represents the average time required to restore an item (assembly, subassembly, and module, end item, or system) to a serviceable condition under typical field operating conditions. This time includes preparation time (including any necessary disassembly/assembly time), troubleshooting/fault location time, and quality assurance time in addition to the time required to perform the specific tasks identified for the maintenance functions authorized in the MAC. The symbol designations for the various maintenance levels are as follows:

- C — Operator or crew maintenance
- O — Unit maintenance
- F — Direct support maintenance
- L — Specialized Repair Activity (SRA)<sup>5</sup>
- H — General support maintenance
- D — Depot maintenance

e. Column 5, Tools and Equipment. Column 5 specifies, by code, those common tool sets (not individual tools), common TMDE, and special tools, special TMDE, and special support equipment required to perform the designated function.

f. Column 6, Remarks. When applicable, this column contains a letter code, in alphabetical order, that is keyed to the remarks contained in Section IV.

#### **B-4 EXPLANATION OF COLUMNS IN TOOLS AND TEST EQUIPMENT REQUIREMENTS, SECTION III**

a. Column 1, Tool or Test Equipment Reference Code. The tool or test equipment reference code correlates a code used in the MAC, Section II, Column 5.

b. Column 2, Maintenance Level. The lowest level of maintenance authorized to use the tool or test equipment.

c. Column 3, Nomenclature. Name or identification of the tool or test equipment.

d. Column 4, National Stock Number (NSN). The NSN of the tool or test equipment.

e. Column 5, Tool Number. The manufacturer's part number.

#### **B-5 EXPLANATION OF COLUMNS IN REMARKS, SECTION IV**

a. Column 1, Reference Code. The code recorded in column 6, Section II.

b. Column 2, Remarks. This column lists information pertinent to the maintenance function being performed as indicated in the MAC, Section II.

---

<sup>5</sup>This maintenance level is not included in Section II, column 4, of the MAC. Functions to this level of maintenance are identified by a work-time figure in the "H" column of Section II, column 4, and an associated reference code is used in the Remarks column (6). This code is keyed to section IV, Remarks, and the SRA complete repair application is explained there.

Section II. Maintenance Allocation Chart for AN/PVS-7B and AN/PVS-7D.

(1) GROUP NUMBER	(2) COMPONENT/ASSEMBLY	(3) MAINTENANCE FUNCTION	(4) MAINTENANCE LEVEL					(5) TOOLS AND EQUIP REF CODE	(6) REMARKS CODE
			C	O	F	H	D		
00	AN/PVS-7B, AN/PVS-7D	INSPECT SERVICE REPAIR		0.1 0.1 0.1					A B
01	GOGGLE ASSEMBLY	INSPECT TEST REPAIR TEST REPAIR		0.2 0.3 0.2	0.4 0.9			1 11 1,2,10 3-9,12	C D C C, E, F, G
02	HEADSET ASSEMBLY	INSPECT REPLACE REPAIR		0.1 0.1 0.1					H



**Section III. Tools and Test Equipment Requirements for AN/PVS-7B and AN/PVS-7D.**

TOOL OR TEST EQUIPMENT REF CODE	MAINTENANCE LEVEL	NOMENCLATURE	NATIONAL STOCK NUMBER	TOOL NUMBER
1	O, F	Test Set, Electronic System, TS-4348/UV	6625-01-323-9584	80063-A3139775
2	F	Test Set, TS-3895A/UV	6625-01-301-6894	80063-A3134100
3	F	Multimeter	6625-01-139-2512	PSM-45 or equivalent
4	F	Tool Kit, Electronic Equipment, TK-105/G ( <b>Army</b> )	5180-00-610-8177	80058-TK105G
		<b>OR</b>		
		Tool Kit, Electronic-Optical Repair ( <b>Marine Corps</b> )	5180-01-382-1335	TAMCN:E22082E
5	F	Device, Purge	5855-01-246-6815	54490-5007665
6	F	Nitrogen, Technical 336 cubic feet	6830-01-265-4068	81348-BB-N-411
		<b>OR</b>		
		Nitrogen, Technical 81 cubic feet		
7	F	Adapter, Goggles, Night Vision	5855-01-151-4211	80063-SM-C-657451
8	F	Pliers, Slip Joint	5120-00-624-8065	39428-555A3
9	F	Purging Kit, Fire Control	4931-00-065-1110	19200-SC4931-95CLJ54
10	F	Light, Infrared Transmitter	6240-01-275-8080	80063-A3085081
11	O	Tool Kit, Electronic Equipment, TK-101/G ( <b>Army</b> )	5180-00-064-5178	80058-TK101GISSUE6
12	F	Wrench, 1 1/8" Open End Box	5120-01-335-1264	55719-OEX36B
13	F	Tape Measuring	5210-00-293-3505	81348-GGG-T-106

Section IV. Remarks.

REMARKS CODE	REMARKS
A	Service by cleaning the system.
B	Repair by replacing the shipping case, if available.
C	Dark adaptation takes at least 10 minutes (longer if exposed to bright sunlight before inspection).
D	Repair by replacing the headmount, helmet mount, carrying case, carrying case strap, tethering cord, compass, sacrificial window, IR spot/flood lens, LIF, demist shields, neck cord, eyecups, objective lens cap, battery cap, or power switch knob.
E	Repair by replacing the image intensifier, rear cover, wired housing, objective lens, or collimator.
F	Nitrogen purging is required.
G	Turn in Image Intensifier to DRMO when out of warranty (para 1-7) when Image Intensifier is still under warranty.
H	Repair by replacing the browpad, chinstrap, neck pad, or strap assemblies.

## APPENDIX C

### REPAIR PARTS AND SPECIAL TOOLS LIST

---

#### Section I. Introduction.

#### C-1 SCOPE

This Repair Parts and Special Tools List (RPSTL) authorizes spares and repair parts, special tools, special test, measurement, and diagnostic equipment (TMDE), and other special support equipment required for performance of direct support maintenance and unit support maintenance of the NVG. It authorizes the requisitioning, issue, and disposition of spares, repair parts, and special tools as indicated by the source, maintenance, and recoverability (SMR) codes.

#### C-2 GENERAL

In addition to Section I, Introduction, this Repair Parts and Special Tools List is divided into the following sections:

a. Section II. Repair Parts List. A list of spares and repair parts authorized by this RPSTL for use in the performance of maintenance. The list also includes parts that must be removed for replacing authorized parts. The parts lists are composed of functional groups in ascending alphanumeric sequence, with the parts in each group listed in ascending figure and item number sequence. Items listed are shown on the associated illustration(s)/figure(s).

b. Section III. Special Tools List. A list of special tools authorized by this RPSTL (as indicated by Basis of Issue (BOI) information in DESCRIPTION AND USABLE ON CODE column) for the performance of maintenance.

c. Section IV. National Stock Number and Part Number Index. A list, in National Item Identification Number (NIIN) sequence, of all national stock numbered items appearing in the list, followed by a list in alphanumeric sequence, of all part numbers appearing in the lists. National stock numbers and part numbers are cross-referenced to each illustration figure and item number appearance.

#### C-3 EXPLANATION OF COLUMNS (Sections II and III).

a. ITEM NO. (Column (1)). Indicates the number used to identify items called out in the illustration.

b. SMR CODE (Column (2)). The Source, Maintenance, and Recoverability (SMR) code is a 5-position code containing supply/requisitioning information, maintenance category authorization criteria, and disposition instructions, as explained in Table C-1.

#### NOTE

AIR FORCE ONLY - Refer to Tech Order 00-25-195 for SMR Applicability.

Table C-1. Application of Joint Services SMR Codes.

SOURCE			MAINTENANCE				
			USE		REPAIR		
1 <sup>ST</sup> POSITION		2 <sup>ND</sup> POSITION		3 <sup>RD</sup> POSITION		4 <sup>TH</sup> POSITION	
P	PROCURE	A	REPLENISH	O	REPLACE OR USE AT ORG LEVEL	Z	NO REPAIR (CONSUMABLE)
		B	INSURANCE				
		C	CURE DATED				
		D	INITIAL	F	REPLACE OR USE AT IMA LEVEL	B	RECONDITION BY ADJUSTMENT, CALIBRATION, LUBRICATION, PLATING, ETC.
		E	END ITEM GSE/STOCKED				
		F	GSE/NOT STOCKED				
K	REPAIR KIT COMPONENT	F	ORG/IMA	G	REPLACE OR USE AT SPECIALIZED IMA	O	REPAIR AT ORGANIZATIONAL LEVEL
		D	DEPOT	L			
		B	BOTH KITS				
M A	MANUFACTURE ASSEMBLE	O	ORG	D	REPLACE OR USE AT DEPOT	F	REPAIR AT IMA LEVEL
		F	AFLOAT				
		H	ASHORE				
		G	BOTH				
		D	DEPOT			G	
X	MISC	A	REQUEST NHA	Z	NOT REQUIRED FOR THIS APPLICATION	L	REPAIR AT SPECIALIZED IMA
		B	OBTAIN FROM SALVAGE OR ONE TIME BUY			D	REPAIR AT DEPOT OR COMMERCIAL
		C	DIAGRAMS, SCHEMATICS, INSTALL DWGS				

RECOVERABILITY		SERVICE OPTION	
5 <sup>TH</sup> POSITION		6 <sup>TH</sup> POSITION	
Z	NONREPAIRABLE CONDEMN AT INDICATED IN POSITION 3	N	CONSUMABLE GAM ITEM NOT CENTRALLY PROCURED OR STOCK NUMBERED
A	SPECIAL HANDLING FOR DISPOSAL	M	FLR ITEM WITH UNIT COST OVER \$5,000. CHANGE 5 <sup>TH</sup> POSITION TO "D"
O	REPAIRABLE ITEM CONDEMN AT ORGANIZATIONAL LEVEL	T	TRAINING DEVICE ITEM SOURCE CODED PD
H F G	REPAIRABLE ITEM CONDEMN AT IMA LEVEL	G	NORMALLY PROCURED COMMERCIAL, BUT ORGANIC CAPABILITY EXISTS FOR EMERGENCY STOP GAP REQUIREMENTS
		1	(APPLY TO ENGINES)
		2	(APPLIES TO 3 <sup>RD</sup> POSITION)
		3	DESIGNATED LOWEST DEGREE OF IMA REPAIR AUTHORITY
L	REPAIRABLE ITEM CONDEMN AT SPECIALIZED IMA	4	(APPLY TO ENGINES)
		5	(APPLIES TO 3 <sup>RD</sup> POSITION)
		6	SAME AS 1-2-3 EXCEPT ITEM IS FLR COSTING MORE THAN \$5,000
D	REPAIRABLE AT DEPOT OR COMMERCIAL	E	END-TO-END TEST BY IMA REQUIRED PRIOR TO BOM
		J	FLR OR CONSUMABLE CHANGE 5 <sup>TH</sup> POSITION TO "D" UNDER PICA/SICA PROGRAM (APPROVAL REQUIRED)

- c. NATIONAL STOCK NUMBER (Column(3)). This column lists the NSN for the associated part number and manufacturer identified in the PART NUMBER and CAGEC columns to the right.
- d. CAGEC (Column (4)). The Commercial and Government Entity Code (CAGEC) is a 5-digit code which is used to identify the manufacturer, distributor, or government agency/activity, that supplies the item.
- e. PART NUMBER (Column (5)). Indicates the primary number used by the manufacturer (individual, company, firm, corporation, or government activity), which controls the design and characteristics of the item by means of its engineering drawings, specifications, standards, and inspection requirements to identify an item or range of items.

**NOTE**

When you use an NSN to requisition an item, the item you receive may have a different part number from the number listed.

- f. DESCRIPTION AND USABLE ON CODE (UOC) (Column (6)). This column includes the following information:
  - (1) The federal item name, and when required, a minimum description to identify the item.
  - (2) The physical security classification of the item is indicated by the appropriate parenthetical entry, e. g., Phy Sec C1 (C) -Confidential, Phy Sec C1 (S) -Secret, Phy Sec C1 (T) - Top Secret).
  - (3) Items that are included in kits and sets are listed below the name of the kit or set.
  - (4) Spare/repair parts that make up an assembled item are listed immediately following the assembled item line entry.
  - (5) Part numbers for bulk materials are referenced in the column in the line entry for the item to be manufactured/fabricated.
  - (6) When the item is not used with all serial numbers of the same model, the effective serial numbers are shown on the last line of the description (before UOC).
  - (7) The UOC, when applicable (para C-5, Special Information).
  - (8) In the Special Tools List Section, the basis of issue (BOI) appears as the last line(s) in the entry for each special tool, special TMDE, and other special support equipment. When density of equipment supported exceeds density spread indicated in the basis of issue, the total authorization is increased proportionately.
  - (9) The statement "END OF FIGURE" appears just below the last item description in Column 6 for a given figure in both Section II and Section III.
- g. QTY (Column (7)). The QTY (quantity per figure column) indicates the quantity of the item used in the breakout shown on the illustration figure, which is prepared for a functional group, sub-functional group, or assembly. A "V" appearing in this column instead of a quantity indicates that the quantity is variable and the quantity may change from application to application.

**C-4. EXPLANATION OF COLUMNS**

a. NATIONAL STOCK NUMBER (NSN) INDEX.

- (1) STOCK NUMBER column. This column lists the NSN by NIIN sequence. The NIIN consists of the last nine digits of the NSN. An example is shown below.

NSN  
5855-01-432-0524  
NIIN

When using this column to locate an item, ignore the first four digits of the NSN. However, the complete NSN should be used when ordering items by stock number.

- (2) FIG. column. This column lists the number of the figure where the item is identified/located. The figures are in numerical order in Section II and Section III.
- (3) ITEM column. The item number identifies the item associated with the figure listed in the adjacent FIG. column. This item is also identified by the NSN listed on the same line.
- (4) CAGEC column. The Commercial and Government Entity (CAGE) code is a 5-digit numeric code used to identify the manufacturer, distributor, or government agency, etc., that supplies the item.
- (5) PART NUMBER column. Indicates the primary number used by the manufacturer (individual, firm, corporation, or government activity), which controls the design and characteristics of the item by means of its engineering drawings, specifications, standards, and inspection requirements to identify an item or range of items.

b. PART NUMBER INDEX. Part numbers in this index are listed by part number in ascending alphanumeric sequence (vertical arrangement of letter and number combination which places the first letter or digit of each group in order A through Z, followed by the numbers 0 through 9 and each following letter or digit in like order).

- (1) CAGEC column. The Commercial and Government entity (CAGE) code is a 5-digit numeric code used to identify the manufacturer, distributor, or government agency, etc., that supplies the item.
- (2) PART NUMBER column. Indicates the primary number used by the manufacturer (individual, firm, corporation, or government activity), which controls the design and characteristics of the item by means of its engineering drawings, specifications, standards, and inspection requirements to identify an item or range of items.
- (3) STOCK NUMBER column. This column lists the NSN for the associated part number and manufacturer identified in the PART NUMBER and CAGEC columns to the left.
- (4) FIG. column. This column lists the number of the figure where the item is identified/located in Sections II and III.
- (5) ITEM column. The item number is that number assigned to the item as it appears in the figure referenced in the adjacent figure number column.

c. FIGURE NUMBER INDEX.

- (1) FIG. column. This column lists the number of the figure where the item is identified/located. The figures are in numerical order in Section II and Section III.
- (2) ITEM column. The item number identifies the item associated with the figure listed in the adjacent FIG. column. This item is also identified by the NSN listed on the same line.
- (3) STOCK NUMBER column. This column lists the NSN by NIIN sequence. The NIIN consists of the last nine digits of the NSN. An example is shown below.

NSN
<u>5855-01-432-0524</u>
NIIN

- (4) CAGEC column. The Commercial and Government Entity (CAGE) code is a 5-digit numeric code used to identify the manufacturer, distributor, or government agency, etc., that supplies the item.
- (5) PART NUMBER column. Indicates the primary number used by the manufacturer (individual, firm, corporation, or government activity), which controls the design and characteristics of the item by means of its engineering drawings, specifications, standards, and inspection requirements to identify an item or range of items.

**C-5. SPECIAL INFORMATION.**

- a. UOC. The UOC, when applicable, appears at the right side of the Description column, next to the corresponding part number. UOC's identify parts which are not used on all models. Uncoded items are applicable to all models. Examples of UOC's (CODE) and their corresponding model numbers (USED ON) are:

CODE	USED ON
HKG	AN/PVS-7B
LDF	AN/PVS-7D

**C-6. HOW TO LOCATE REPAIR PARTS.**

- a. When National Stock Number or Part Number is Not Known:
  - (1) First. Using the table of contents, determine the assembly group or subassembly group to which the item belongs. This is necessary since figures are prepared for assembly groups and subassembly groups, and listings are divided into the same groups.
  - (2) Second. Find the figure covering the assembly group or subassembly group to which the item belongs.
  - (3) Third. Identify the item on the figure and note the item number.

## **TM 11-5855-262-23&P-2**

### **C-6. HOW TO LOCATE REPAIR PARTS – Continued.**

(4) Fourth. Refer to the Repair Parts List for the figure to find the part number for the item number noted on the figure.

(5) Fifth. Refer to the Part Number Index to find the NSN, if assigned.

b. When National Stock Number or Part Number is Known:

(1) First. Using the Index of National Stock Numbers and Part Numbers, find the pertinent National Stock Number or Part Number. The NSN index is in National Item Identification Number (NIIN) sequence (C-4. a (3)). The part numbers in the Part Number index are listed in ascending alphanumeric sequence (C-4. b). Both indexes cross-reference you to the illustration figure and item number of the item you are looking for.

(2) Second. After finding the figure and item number, verify that the item is the one you're looking for, then locate the item number in the repair parts list for the figure.

### **C-7. ABBREVIATIONS.**

NOT APPLICABLE



Section II. Repair Parts List.

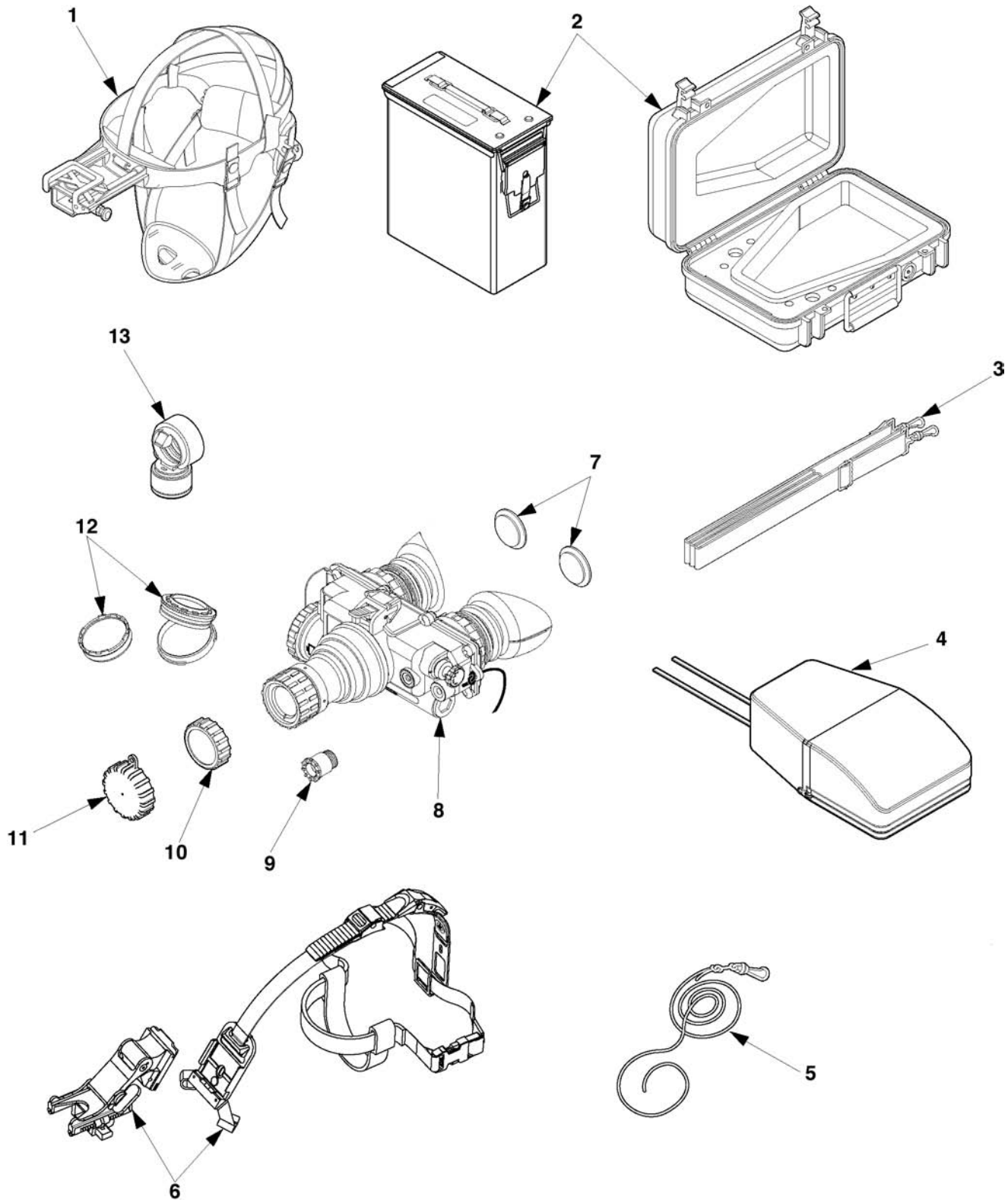

Figure C-1. Night Vision Goggles (NVG), AN/PVS-7B and AN/PVS-7D.

Section II. Repair Parts List - Continued

(1)	(2)	(3)	(4)	(5)	(6)	(7)
ITEM NO.	SMR CODE	NATIONAL STOCK NUMBER	CAGEC	PART NUMBER	DESCRIPTION AND USABLE ON CODE (UOC)	QTY
				<b>GROUP 00</b>	<b>NIGHT VISION GOGGLES AN/PVS-7B, AN/PVS-7D</b>	
					<b>FIGURE C-1</b>	
1	PAOOO	5855-01-246-8266	80063	A3144268	HEADSET ASSEMBLY (FIGURE C-3 FOR PARTS BREAKDOWN)	1
2	XBOZZ	5855-01-246-6805	80063	A3144257	CASE, SHIPPING	1
2	XBOZZ		80063	A3264350	CASE, SHIPPING	1
3	PAOZZ	5340-01-250-2431	80063	A3144267	STRAPPING	1
4	PAOZZ	5855-01-398-4284	80063	A3187392	CASE, INFRARED EQUIPMENT	1
5	PAOZZ	5340-01-451-7737	80063	A3260933	CLIP, RETAINING	1
6	PAOZZ	5855-01-457-2953	80063	A3256368	MOUNT VIEWER	1
7	PAOZZ	5855-01-246-8272	80063	A3144263	DEMIST SHIELD ASSY	2
8	XAFFF		80063	A3144261-1	GOGGLE ASSEMBLY HKG (SEE FIG C-2 FOR PARTS BREAKDOWN)	1
8	XAFFF		80063	A3144261-2	GOGGLE ASSEMBLY LDF (SEE FIG C-2 FOR PARTS BREAKDOWN)	1
9	PAOZZ	5855-01-382-5169	80063	A3187441	LENS ASSEMBLY, FOCUSING	1
10	PAOZZ	5855-01-246-8271	80063	A3144264	WINDOW, SACRIFICIAL	1
11	PAOZZ	5340-01-397-6608	80063	A3144318	CAP-, PROTECTIVE, DUST	1
12	PAOZZ	5855-01-379-1410	54490	5009737	FILTER, LIGHT INTERFER	1
13	PAOZZ	5855-01-381-6052	80063	A3187430	COMPASS ASSEMBLY	1

END OF FIGURE

Section II. Repair Parts List – Continued

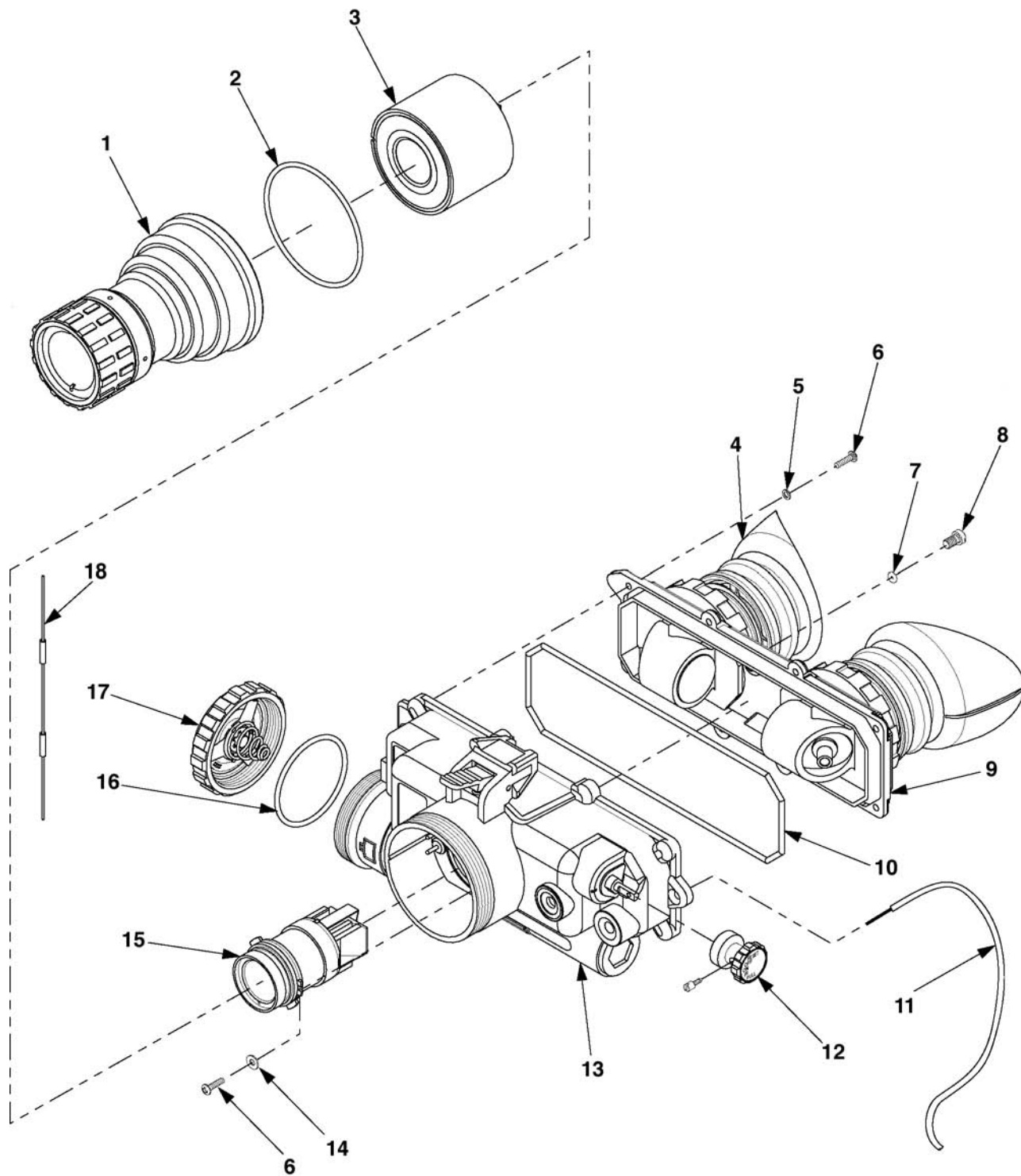

Figure C-2. Goggle Assembly, AN/PVS-7B and AN/PVS-7D.

Section II. Repair Parts List - Continued

(1)	(2)	(3)	(4)	(5)	(6)	(7)
ITEM NO.	SMR CODE	NATIONAL STOCK NUMBER	CAGEC	PART NUMBER	DESCRIPTION AND USABLE ON CODE (UOC)	QTY
				GROUP 01	GOGGLE ASSEMBLY	
					FIGURE C-2	
1	PAFZZ	5855-01-246-6807	80063	A3144305	MOUNT ASSEMBLY, OBJECTIVE	1
2	PAFZZ	5330-01-049-7374	96906	MS28775-032	PACKING, PREFORMED	1
3	PAFZA	5855-01-422-4720	80063	A3256388	IMAGE INTENSIFIER, N	1
4	PAOZZ	5855-01-246-8273	80063	A3144422	EYECUP	2
5	PAFZZ	5310-00-043-4708	80063	A3144314	WASHER, FLAT	8
6	PAFZZ	5305-00-224-0783	96906	MS51957-4B	SCREW, MACHINE	10
7	PAFZZ	5330-01-356-7219	80063	A3144316	PACKING, PREFORMED	1
8	PAFZZ	5305-01-266-9341	80063	A3144315	SCREW, MACHINE	1
9	PAFZZ	5855-01-246-6810	80063	A3144310	REAR COVER ASSEMBLY	1
10	PAFZZ	5330-01-098-1232	96906	MS28775-044	PACKING, PREFORMED	1
11	PAOZZ	4020-01-446-8097	80063	A3144306	CORD, FIBROUS	1
12	PAOZZ	5930-01-246-8264	80063	A3144404	SWITCH, KNOB ASSEMBLY	1
13	PAFZZ	5855-01-381-6048	80063	A3207330	WIRED HOUSING ASSY	1
14	PAFZZ	5310-00-433-3599	96906	MS15795-802B	WASHER, FLAT	2
15	PAFZZ	5855-01-246-6808	80063	A3172531	COLLIMATOR, INFRARED	1
16	PAOZZ	5330-00-729-4992	96906	MS28775-027	PACKING, PREFORMED	1
17	PAOZZ	5855-01-246-8265	80063	A3144394	BATTERY CAP ASSEMBLY	1
18	PAOZZ	5935-01-448-6355	80063	A3260939	RETAINER, ELECTRICAL	1

END OF FIGURE

Section II. Repair Parts List - Continued

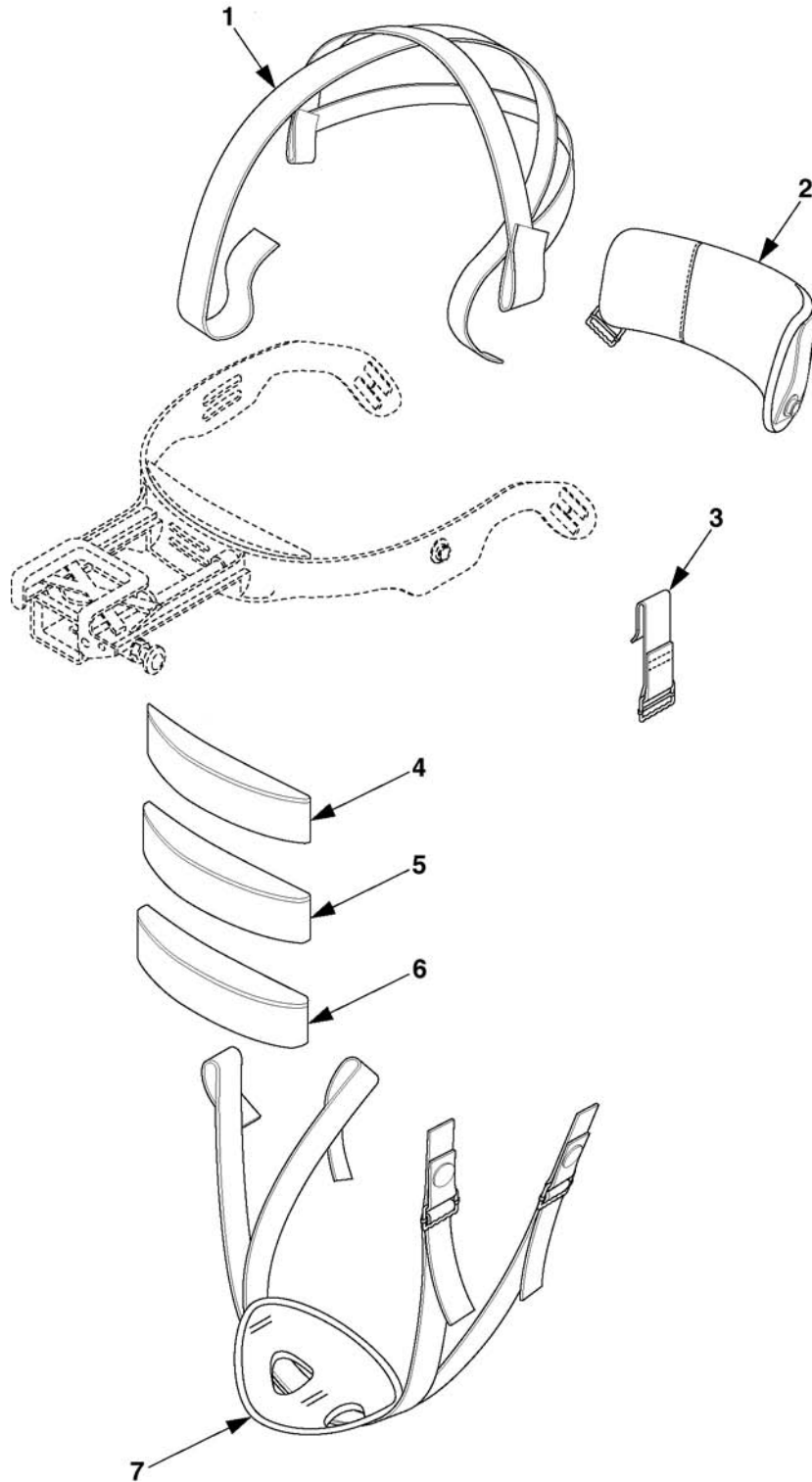

Figure C-3. Headset Assembly.

Section II. Repair Parts List - Continued

(1)	(2)	(3)	(4)	(5)	(6)	(7)
ITEM NO.	SMR CODE	NATIONAL STOCK NUMBER	CAGEC	PART NUMBER	DESCRIPTION AND USABLE ON CODE (UOC)	QTY
				GROUP 02	HEADSET ASSEMBLY	
					FIGURE C-3	
1	PAOZZ	5340-01-306-9354	80063	A3144292	STRAPPING	1
2	PAOZZ	5855-01-297-7846	80063	A3144290	NECK PAD ASSEMBLY	1
3	PAOZZ	5340-01-360-1724	80063	A3144293	STRAP, WEBBING	1
4	PAOZZ	5855-01-297-7847	80063	A3144436	BROWPAD ASSY, THICK	1
5	PAOZZ	5855-01-355-8600	80063	A3144435	BROWPAD ASSY, MEDIUM	1
6	PAOZZ	5855-01-355-8599	80063	A3144280	BROWPAD ASSY, THIN	1
7	PAOZZ	5855-01-283-2870	80063	A3144286	CHINSTRAP, HELMET	1

END OF FIGURE

Section III. Special Tools List.

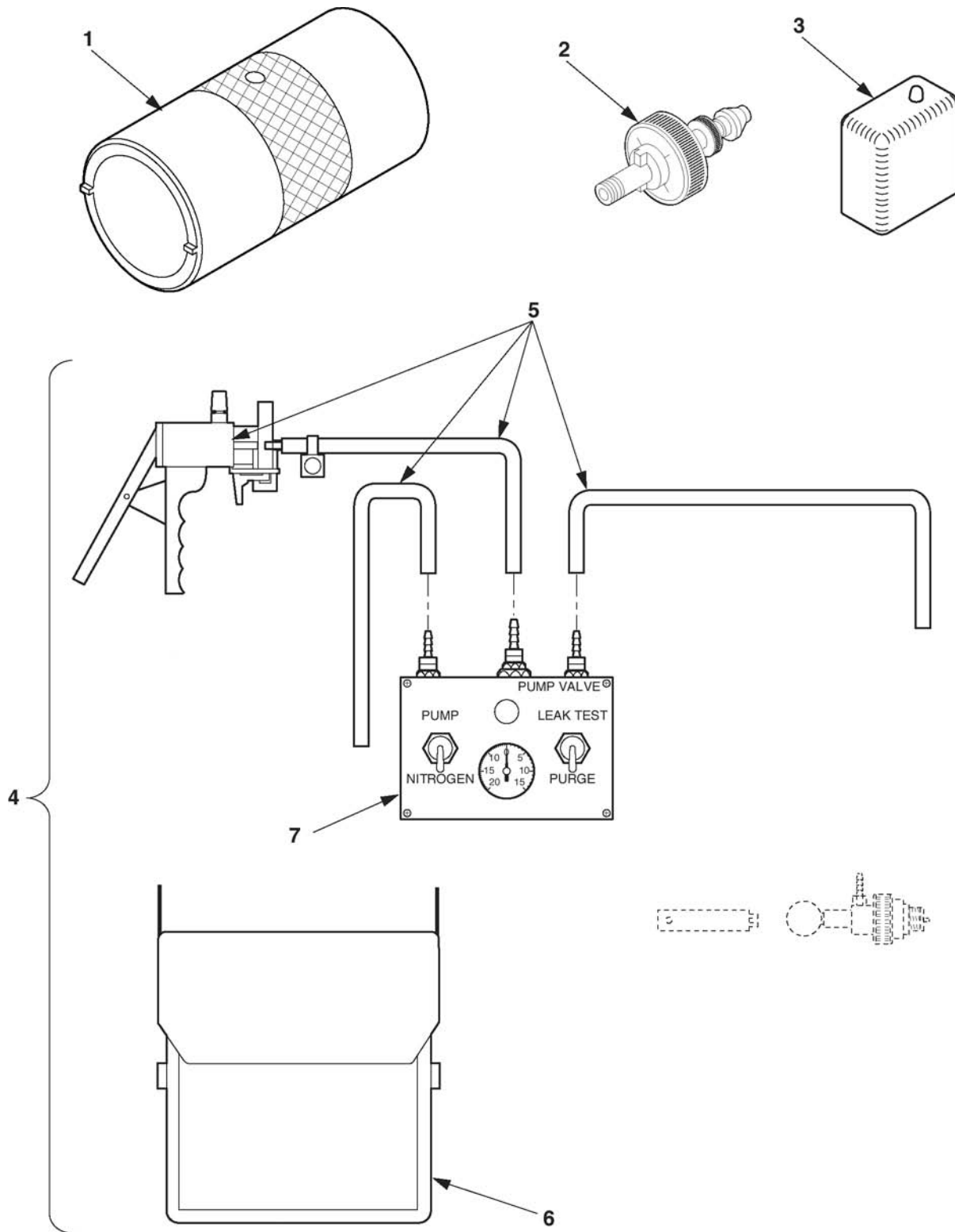

Figure C-4. Special Tools List.

Section III. Special Tools List - Continued

(1)	(2)	(3)	(4)	(5)	(6)	(7)
ITEM NO.	SMR CODE	NATIONAL STOCK NUMBER	CAGE CODE	PART NUMBER	DESCRIPTION AND USABLE ON CODE (UOC)	QTY
				GROUP 10	SPECIAL TOOLS	
					FIGURE C-4	
1	PAFZZ	5120-00-345-1406	19200	7597658	WRENCH, SPANNER BOI: 1 PER UNIT	1
2	PAFZZ	5855-01-151-4211	80063	SM-C-657451	PURGE ADAPTER	1
3	PAFZZ	6240-01-275-8080	80063	A3085081	LIGHT, INFRARED TRANSMITTER	1
4	PEFFF	5855-01-246-6815	54490	5007665	DEVICE, PURGE	1
5	PAFZZ	5855-01-250-2359	54490	5007678	HOSE SET, VACUUM	1
6	PAFZZ	5855-01-250-2361	54490	5007693	CASE, CARRYING	1
7	XAFZZ	5855-01-250-2358	54490	5007679	HOUSING, IMAGE INTEN	1

END OF FIGURE



**Section IV.**  
**CROSS-REFERENCE INDEXES**  
**NATIONAL STOCK NUMBER INDEX**

STOCK NUMBER	FIG	ITEM	CAGEC	PART NUMBER
5310-00-043-4708	C-2	5	80063	A3144314
5305-00-224-0783	C-2	6	96906	MS51957-4B
5120-00-345-1406	C-4	1	19200	7597658
5310-00-433-3599	C-2	14	96906	MS15795-802B
5330-00-729-4992	C-2	16	96906	MS28775-027
5330-01-049-7374	C-2	2	96906	MS28775-032
5330-01-098-1232	C-2	10	96906	MS28775-044
5855-01-151-4211	C-4	2	80063	SM-C-657451
5855-01-246-6805	C-1	2	80063	A3144257
5855-01-246-6807	C-2	1	80063	A3144305
5855-01-246-6808	C-2	15	80063	A3172531
5855-01-246-6810	C-2	9	80063	A3144310
5855-01-246-6815	C-4	4	54490	5007665
5930-01-246-8264	C-2	12	80063	A3144404
5855-01-246-8265	C-2	17	80063	A3144394
5855-01-246-8266	C-1	1	80063	A3144268
5855-01-246-8271	C-1	10	80063	A3144264
5855-01-246-8272	C-1	7	80063	A3144263
5855-01-246-8273	C-2	4	80063	A3144422
5855-01-250-2358	C-4	7	54490	5007679
5855-01-250-2359	C-4	5	54490	5007678
5855-01-250-2361	C-4	6	54490	5007693
5340-01-250-2431	C-1	3	80063	A3144267
5305-01-266-9341	C-2	8	80063	A3144315
6240-01-275-8080	C-4	3	80063	A3085081
5855-01-283-2870	C-3	7	80063	A3144286
5855-01-297-7846	C-3	2	80063	A3144290
5855-01-297-7847	C-3	4	80063	A3144436
5340-01-306-9354	C-3	1	80063	A3144292
5855-01-355-8599	C-3	6	80063	A3144280
5855-01-355-8600	C-3	5	80063	A3144435
5330-01-356-7219	C-2	7	80063	A3144316
5340-01-360-1724	C-3	3	80063	A3144293
5855-01-379-1410	C-1	12	54490	5009737
5855-01-381-6048	C-2	13	80063	A3207330
5855-01-381-6052	C-1	13	80063	A3187430
5855-01-382-5169	C-1	9	80063	A3187441
5340-01-397-6608	C-1	11	80063	A3144318
5855-01-398-4284	C-1	4	80063	A3187392
5855-01-422-4720	C-2	3	80063	A3256388
5855-01-457-2953	C-1	6	80063	A3256368
4020-01-446-8097	C-2	11	80063	A3144306
5935-01-448-6355	C-2	18	80063	A3260939

**Section IV. - Continued**  
**CROSS-REFERENCE INDEXES**  
**NATIONAL STOCK NUMBER INDEX - Continued**

STOCK NUMBER	FIG	ITEM	CAGEC	PART NUMBER
5340-01-451-7737	C-1	5	80063	A3260933
	C-1	2	80063	A3264350
	C-1	8	80063	A3144261-1
	C-1	8	80063	A3144261-2

**Section IV. - Continued**  
**CROSS-REFERENCE INDEXES**  
**PART NUMBER INDEX**

PART NUMBER	CAGEC	STOCK NUMBER	FIG	ITEM
5009737	54490	5855-01-379-1410	C-1	12
5007678	54490	5855-01-250-2359	C-4	5
5007679	54490	5855-01-250-2358	C-4	7
5007693	54490	5855-01-250-2361	C-4	6
7597658	19200	5120-00-345-1406	C-4	1
A3085081	80063	6240-01-275-8080	C-4	3
A3144257	80063	5855-01-246-6805	C-1	2
A3144261-1	80063		C-1	8
A3144261-2	80063		C-1	8
A3144263	80063	5855-01-246-8272	C-1	7
A3144264	80063	5855-01-246-8271	C-1	10
A3144267	80063	5340-01-250-2431	C-1	3
A3144268	80063	5855-01-246-8266	C-1	1
A3144280	80063	5855-01-355-8599	C-3	6
A3144286	80063	5855-01-283-2870	C-3	7
A3144290	80063	5855-01-297-7846	C-3	2
A3144292	80063	5340-01-306-9354	C-3	1
A3144293	80063	5340-01-360-1724	C-3	3
A3144305	80063	5855-01-246-6807	C-2	1
A3144306	80063	4020-01-446-8097	C-2	11
A3144310	80063	5855-01-246-6810	C-2	9
A3144314	80063	5310-00-043-4708	C-2	5
A3144315	80063	5305-01-266-9341	C-2	8
A3144316	80063	5330-01-356-7219	C-2	7
A3144318	80063	5340-01-397-6608	C-1	11
A3144394	80063	5855-01-246-8265	C-2	17
A3144404	80063	5930-01-246-8264	C-2	12
A3144422	80063	5855-01-246-8273	C-2	4
A3144435	80063	5855-01-355-8600	C-3	5
A3144436	80063	5855-01-297-7847	C-3	4
A3172531	80063	5855-01-246-6808	C-2	15
A3187392	80063	5855-01-398-4284	C-1	4
A3187430	80063	5855-01-381-6052	C-1	13
A3187441	80063	5855-01-382-5169	C-1	9
A3207330	80063	5855-01-381-6048	C-2	13
A3256388	80063	5855-01-422-4720	C-2	3
A3256368	80063	5855-01-457-2953	C-1	6
A3260933	80063	5340-01-451-7737	C-1	5
A3260939	80063	5935-01-448-6355	C-2	18
A3264350	80063		C-1	2
5007665	54490	5855-01-246-6815	C-4	4
MS15795-802B	96906	5310-00-433-3599	C-2	14
MS28775-027	96906	5330-00-729-4992	C-2	16

**Section IV. - Continued**  
**CROSS-REFERENCE INDEXES**  
**PART NUMBER INDEX - Continued**

PART NUMBER	CAGEC	STOCK NUMBER	FIG	ITEM
MS28775-032	96906	5330-01-049-7374	C-2	2
MS28775-044	96906	5330-01-098-1232	C-2	10
MS51957-4B	96906	5305-00-224-0783	C-2	6
SM-C-657451	80063	5855-01-151-4211	C-4	2

**Section IV-Continued**  
**CROSS-REFERENCE INDEXES**  
**FIGURE AND ITEM NUMBER INDEX**

FIG	ITEM	STOCK NUMBER	CAGEC	PART NUMBER
C-1	1	5855-01-246-8266	80063	A3144268
C-1	2	5855-01-246-6805	80063	A3144257
C-1	2		80063	A3264350
C-1	3	5340-01-250-2431	80063	A3144267
C-1	4	5855-01-398-4284	80063	A3187392
C-1	5	5340-01-451-7737	80063	A3260933
C-1	6	5855-01-457-2953	80063	A3256368
C-1	7	5855-01-246-8272	80063	A3144263
C-1	8		80063	A3144261-1
C-1	8		80063	A3144261-2
C-1	9	5855-01-382-5169	80063	A3187441
C-1	10	5855-01-246-8271	80063	A3144264
C-1	11	5340-01-397-6608	80063	A3144318
C-1	12	5855-01-379-1410	54490	5009737
C-1	13	5855-01-381-6052	80063	A3187430
C-2	1	5855-01-246-6807	80063	A3144305
C-2	2	5330-01-049-7374	96906	MS28775-032
C-2	3	5855-01-422-4720	80063	A3256388
C-2	4	5855-01-246-8273	80063	A3144422
C-2	5	5310-00-043-4708	80063	A3144314
C-2	6	5305-00-224-0783	96906	MS51957-4B
C-2	7	5330-01-356-7219	80063	A3144316
C-2	8	5305-01-266-9341	80063	A3144315
C-2	9	5855-01-246-6810	80063	A3144310
C-2	10	5330-01-098-1232	96906	MS28775-044
C-2	11	4020-01-446-8097	80063	A3144306
C-2	12	5930-01-246-8264	80063	A3144404
C-2	13	5855-01-381-6048	80063	A3207330
C-2	14	5310-00-433-3599	96906	MS15795-802B
C-2	15	5855-01-246-6808	80063	A3172531
C-2	16	5330-00-729-4992	96906	MS28775-027
C-2	17	5855-01-246-8265	80063	A3144394
C-2	18	5935-01-448-6355	80063	A3260939
C-3	1	5340-01-306-9354	80063	A3144292
C-3	2	5855-01-297-7846	80063	A3144290
C-3	3	5340-01-360-1724	80063	A3144293
C-3	4	5855-01-297-7847	80063	A3144436
C-3	5	5855-01-355-8600	80063	A3144435
C-3	6	5855-01-355-8599	80063	A3144280
C-3	7	5855-01-283-2870	80063	A3144286
C-4	1	5120-00-345-1406	19200	7597658
C-4	2	5855-01-151-4211	80063	SM-C-657451
C-4	3	6240-01-275-8080	80063	A3085081
C-4	4	5855-01-246-6815	54490	5007665

**Section IV. - Continued**  
**CROSS-REFERENCE INDEXES**

**FIGURE AND ITEM NUMBER INDEX - Continued**

FIG	ITEM	STOCK NUMBER	CAGEC	PART NUMBER
C-4	5	5855-01-250-2359	54490	5007678
C-4	6	5855-01-250-2361	54490	5007693
C-4	7	5855-01-250-2358	54490	5007679

## APPENDIX D EXPENDABLE AND DURABLE ITEMS LIST

### Section I. Introduction.

#### D-1 SCOPE

This appendix lists expendable and durable items that you will need to operate and maintain the Night Vision Goggles (NVG), AN/PVS-7B and AN/PVS-7D. This listing is for information only and is not authority to requisition the listed items. These items are authorized to you by CTA 50-970, Expendable/Durable Items (Except Medical, Class V Repair Parts, and Heraldic Items) or CTA 8-100, Army Medical Department Expendable/Durable Items.

#### D-2 EXPLANATION OF COLUMNS

**a. Item Number (Column 1).** This number is assigned to the entry in the listing for referencing when required.

**b. Level (Column 2).** This column identifies the lowest level of maintenance that requires the item.

- C — Operator/Crew
- O — Unit Maintenance
- F — Direct Support Maintenance
- H — General Support Maintenance
- D — Depot

**c. National Stock Number (Column 3).** This is the NSN assigned to the item; use it to requisition the item.

**d. Description (Column 4).** Indicates the federal item name and, if required, a description to identify the item. The last line for each item indicates the Commercial and Government Entity Code (CAGEC) code in parenthesis followed by the part number.

**e. Unit of Measure (U/M)/Unit of Issue (U/I) (Column 5).** This measure is expressed by a two-character alphabetical abbreviation (e.g., DA, IN, PR). If the unit of measure differs from the unit of issue as shown in the Army Master Data File (AMDF), requisition the lowest unit of issue that will satisfy your requirements.

Section II. Expendable and Durable Items List.

(1)	(2)	(3)	(4)	(5)
ITEM NUMBER	LEVEL	NATIONAL STOCK NUMBER	DESCRIPTION, CAGEC AND PART NUMBER	U/M U/I
1	F	6810-00-753-4993	ISOPROPYL ALCOHOL, TECHNICAL (81348) TT-I-735A	OZ
2	F	9150-01-132-8871	LUBRICANT (SILICONE GREASE)	
3	O	7930-00-926-5280	DETERGENT, GENERAL PURPOSE, SPRAY NON-AMMONIA (81348) P-D-1747	BX
4	F	6830-01-265-4068	NITROGEN, TECHNICAL (81348) BB-N-411	CY
		Or		
		6830-00-973-7283	NITROGEN, TECHNICAL (81348) BB-N-411	EA
5	F	3439-00-552-9309	DISPENSER, ALCOHOL (33092) 3316	EA
6	O	7920-00-823-9773	TOWEL, SHOP (81348) UU-T-595	MX
7	O	6640-01-459-4239	PAPER, LENS (81348) A-A-50177 TYPE I, CLASS 5	PG
8	F	8030-01-390-7555	SEALING COMPOUND (05972) 42540	BT
9	F	6830-00-602-2357	COMPRESSED AIR, TECHNICAL (81348) BB-F-1421	OZ
10	F	6515-00-303-8250	APPLICATOR, DISPOSABLE, WOOD, COTTON-TIPPED END, STERILE (81348) GG-A-616	PG



## APPENDIX E ILLUSTRATED LIST OF MANUFACTURED ITEMS

### Section I. Introduction.

a. This appendix includes complete instructions for making items authorized to be manufactured or fabricated at the unit or direct support (DS) maintenance level. The black spot test stand is authorized for Unit/DS.

b. A part number index in alphanumeric order is provided for cross-referencing the part number of the item to be manufactured to the figure which covers fabrication criteria.

c. All bulk materials needed for manufacture of an item are listed by part number or specification number in a tabular list on the illustration.

### Section II. Manufactured Items Part Number Index.

Fig. No.	Illus. No.	NSN	Description (Part Number, If Applicable)	U/M	Qty Rqd
E-1	1	5855-01-305-8524	BLACK SPOT TARGET	EA	1
E-1	2	N/A	1/2" PLYWOOD, 22 1/2" X 30 1/2" (LOCAL PROCUREMENT)	EA	1
E-1	3	N/A	1/2" PLYWOOD, 22 1/2" X 32" (LOCAL PROCUREMENT)	EA	1
E-1	4	N/A	3/4" PINE BOARD, 2" X 35 3/4" WITH 31° MITER ENDS (LOCAL PROCUREMENT)	EA	2
E-1	5	N/A	3/4" PINE BOARD, 2" X 12 1/4" (LOCAL PROCUREMENT)	EA	2
E-1	6	N/A	3/4" PINE BOARD, 5" X 24" (LOCAL PROCUREMENT)	EA	1
E-1	7	N/A	WOOD SCREWS, 3" (LOCAL PROCUREMENT)	EA	4
E-1	8	N/A	WOOD SCREWS, 1 1/4" (LOCAL PROCUREMENT)	EA	18

Section III. Manufactured Items Illustrations.

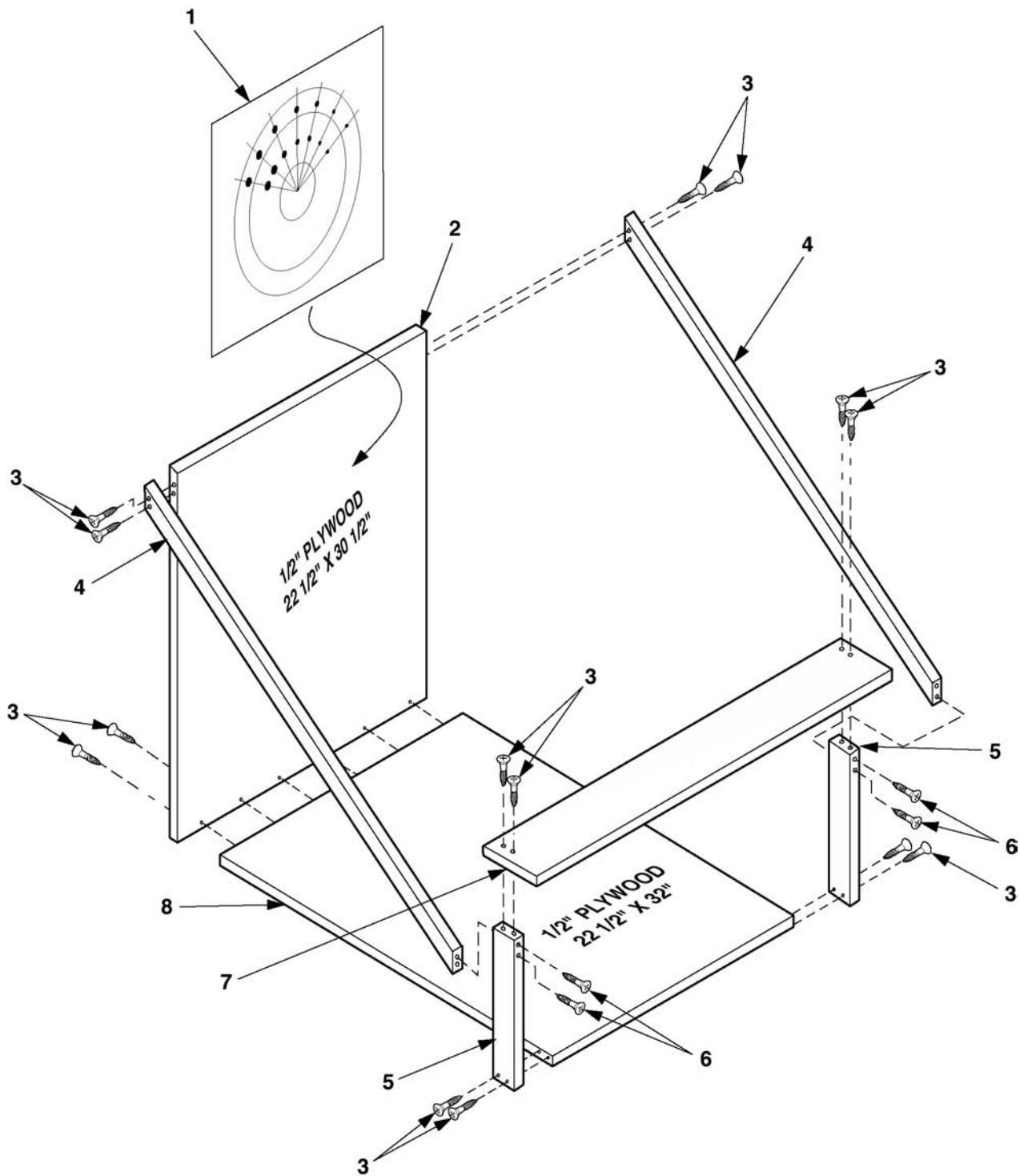

Figure E-1. Black Spot Test Stand.

## GLOSSARY

---

### Section I. Abbreviations.

AMDF	Army Master Data File
BOI	Basis of Issue
CAGEC	Commercial and Government Entity Code
cm	Centimeters
CPC	Corrosion Prevention and Control
CTA	Common Table of Allowances
DA	Department of the Army
DMWR	Depot Modification Work Request
DRMO	Defense Reutilization and Marketing Office
DS	Direct Support
EIC	End Item Code
EIR	Equipment Improvement Recommendations
FM	Field Manual
IAW	In Accordance With
IR	Infrared
lbs	Pounds
LED	Light-Emitting Diode
LIF	Light Interference Filter
MAC	Maintenance Allocation Chart
MCPDS	Marine Corps Publication Distribution System
mm	Millimeter
MTOE	Modified Table of Organization and Equipment
MWO	Modification Work Order
N/A	Not Applicable
NATO	North Atlantic Treaty Organization
NIIN	National Item Identification Number
NSN	National Stock Number
NVG	Night Vision Goggles
Pam	Pamphlet
PASGT	Personal Armor System Ground Troops
PMCS	Preventive Maintenance Checks and Services
POC	Point of Contact
PQDR	Product Quality Deficiency Report
psi	Pounds per Square Inch
Qty	Quantity
RA	Return Authorization
RGA	Return Goods Authorization
RPSTL	Repair Parts and Special Tools List
Rqd	Required
SAMS	Standard Army Maintenance System
SF	Standard Form
SMR	Source, Maintenance and Recoverability
SRA	Specialized Repair Activity
TBD	To Be Determined
TM	Technical Manual
TMDE	Test, Measurement, and Diagnostic Equipment
TO	Technical Order
U/I	Unit of Issue
ULLS	Unit Level Logistics System
U/M	Unit of Measure
UOC	Usable on Code
Vdc	Volts, direct current

## **Section II. Definitions of Unusual Terms.**

**BLACK SPOTS.** These are cosmetic blemishes in the image intensifier of the NVG or dirt or debris between the lenses. Black spots are acceptable as long as they do not interfere with image viewing. No action is required if this condition is present unless the spots interfere with the operator's ability to view the outside scene or the ability to perform the mission.

**BRIGHT SPOTS.** These are signal-induced cosmetic blemishes in the image area caused by a flaw in the film on the microchannel plate. A bright spot is a small, nonuniform bright area that may flicker or appear constant. Not all bright spots make an image intensifier rejectable. Remove the binocular from the TS-3895A/UV test set ports (keeping the goggle connector attached) and cup your hand over the lens to block out all light. If the bright spot remains, it is an emission point. If the spot disappears, place the goggles back onto the test set and turn the selector knob to HIGH LIGHT for 15 seconds and note the spot's location. Turn the selector knob to LOW LIGHT and wait another 15 seconds. If the spot disappears or is faintly visible, it is acceptable.

**BROWPADS.** Three hook-and-pile browpads are provided to adjust the headmount to fit different head sizes. The thin browpad (large head) comes attached to the headmount and the thick (small head) or medium browpads are stored in the carrying case.

**CAUTION.** Condition, practices, or procedures that must be observed to avoid damage to equipment, destruction of equipment, or a long-term health hazard.

**CHICKEN WIRE.** An irregular pattern of dark thin lines in the field-of-view either throughout the image area or in parts of the image area. Under the worst condition, these lines will form hexagonal or square-wave shaped lines.

**DARK (OR DARK AREA).** A place in which there is very little light. It does not mean total darkness. Generally, this means conditions similar to a quarter-moon or starlit night.

**DARK-ADAPTED.** Having ones eyes adjusted to the goggles' output under low light conditions. This takes at least 10 minutes. However, if you have just been exposed to bright sunlight, dark adaptation will take longer.

**DEMIST SHIELDS.** The two demist shields are used to prevent the eyepiece lenses from becoming fogged.

**DIOPTER.** A unit of measure used to define eye correction. Adjustments to the diopter adjustment will provide a clearer image in each eye.

**ELEMENT.** A collection of three vertical and three horizontal lines wherein the height and width of each line and the distance between each line is identical. There are six elements in each group of the resolution test pattern.

**EMISSION POINT.** A steady or fluctuating pinpoint of bright light in the image area and does not go away when all light is blocked from the objective lens of the goggles. The position of an emission point within the image area of the goggles does not move. An emission point should not be confused with a point light source in the distance.

**FIXED-PATTERN NOISE.** This is a cosmetic blemish in the image area characterized by a faint hexagonal (honeycomb) pattern throughout the viewing area that most often occurs at High light levels or when viewing very bright lights. Fixed-pattern noise is inherent in the structure of the fiber optics and can be seen in every image intensifier if the light level is high enough.

**FLASHING.** This is a defect in which the image appears to flicker. This occurs in the image intensifier. If there is more than one flicker, check for loose wires, loose cap, or weak batteries.

**GAIN.** This is the number of times a night vision device amplifies light input.

**GOGGLE ASSEMBLY.** The goggle assembly, hereafter referred to as goggle, is the viewing unit.

**HEADMOUNT.** The adjustable cushioned headmount secures the goggles to the operator's head for night viewing, providing freehand support for use with a weapon, protective mask or other purposes.

**IMAGE INTENSIFIER.** An electro-optical device that detects and amplifies ambient light to produce a visual image. It consists of a photocathode, microchannel plate, phosphor screen optics, and integral power supply.

**INFINITY FOCUS.** Adjustment of the objective lens so that a distant object, such as a star or the point light on a distant tower, forms the sharpest image.

**INTERMITTENT OPERATION.** This a defect in the image area of the NVG. See "flashing."

**IR SOURCE.** This is an IR Light Emitting Diode (LED). When turned on, the IR Source provides additional illumination to enhance existing light conditions. Used only for performing near by tasks.

**LIGHT-INTERFERENCE FILTER (LIF).** This is a light protection filter for the objective lens. Use of this filter will result in a slight reduction in system gain.

**MICROCHANNEL PLATE.** A current-multiplying optical disk that intensifies the electron image produced by the photo-cathode.

**NOTE.** Essential information of special importance, interest, or aid in job performance.

**OBJECTIVE LENS.** This consists of an objective lens cell and an objective focus ring. It attaches to the front of the goggles and adjusts for variations in distance to the viewed area or object.

**PHOTOCATHODE.** The input optic of an image intensifier that absorbs light energy and in turn releases electrical energy in the form of an electron image.

**SACRIFICIAL WINDOW.** A replaceable sacrificial window is supplied to protect the objective lens during operation in adverse conditions.

**SCINTILLATION.** A faint, random, sparkling effect throughout the image area. Scintillation is a normal characteristic of the image intensifier and should not be confused with emission points. Scintillation is more pronounced under low light conditions. Also called "video noise."

**SHADING.** The viewed image should be a full circle. If shading is present, you will not see a fully circular image. Shading is indicative of a dying photocathode and is caused by a defective vacuum seal of the image intensifier. Shading is very dark and you cannot see an image through it.

**WARNING.** Conditions, practices, or procedures that must be observed to avoid personal injury or loss of life.

## ALPHABETICAL INDEX

Subject ..... Para

### A

Abbreviations.....	Glossary
Adjustment	
Goggles .....	1-13
Headmount .....	1-13
Ambient light.....	1-1
Ambient temperature limits .....	1-12
Appendices	
A – References .....	A-1
B – Maintenance Allocation Chart (MAC) Army only .....	B-1
C – Repair Parts and Special Tools List.....	C-1
D Expendable and Durable Items List.....	D-1
E Illustrated List of Manufactured Items.....	E-1

### B

Battery	
AA size .....	1-12
Alkaline .....	1-12
Cap .....	2-12
Lithium .....	1-12
Voltage .....	1-15
Battery Cap and Battery Cap Retainer	
Installation.....	2-12
Removal.....	2-12
Black spots .....	3-11, Appendix E
Browpads .....	1-10
Installation.....	2-13
Removal.....	2-13

### C

Carrying case .....	1-10, 1-12, 2-11
Characteristics .....	1-9
Chinstrap	
Installation.....	2-15
Collimator assembly	
Installation.....	3-15
Removal.....	3-15
Common tools and equipment .....	2-1, 3-1
Components	
Installation.....	2-11
Removal.....	2-11

Subject ..... Para

**C - Continued**

Corrosion prevention and control..... 1-8  
 Cross reference list, nomenclature ..... 1-5  
 Cross-Strap  
     Installation ..... 2-16  
     Removal ..... 2-16

**D**

Data  
     Electrical..... 1-12  
     Environmental ..... 1-12  
     Equipment ..... 1-12  
     Mechanical ..... 1-12, 1-13  
     Optical ..... 1-12  
     Definition of Unusual Terms ..... Glossary  
 Demist shields..... 1-10  
 Destruction of electronic materiel to prevent enemy use ..... 1-3  
 Diopter ..... 1-12, 1-13

**E**

EIR..... 1-6  
 Electrical function ..... 1-15  
 Electronic circuit functions..... 1-15  
 Environmental Data..... 1-12  
 Equipment  
     Characteristics, capabilities and features..... 1-9  
     Data..... 1-12  
     Description ..... 1-10  
 Expendable and durable items list..... Appendix D  
 Eye relief ..... 1-13  
 Eyecups ..... 2-11  
 Eyepiece  
     Focus ..... 1-12  
     Function ..... 1-14

**F**

Field-of-view..... 1-12  
 Filter (See LIF)  
 Forms  
     DA 2404 ..... 1-7  
     DA 2407 ..... 1-7  
     DA Pam 25-30..... 1-2, 2-5  
     DA Pam 738-750..... 1-2  
     DD 1149..... 1-7  
     DRMS 1930..... 3-21  
     SF 364..... 2-5  
     SF 368..... 1-6

Subject ..... Para

**G**

Goggles ..... 1-10

**H**

Headmount ..... 2-11

Helmet mount ..... 2-11

High light

    Cut-off ..... 1-15

    Resolution test ..... 2-10, 3-9

**I, J**

Illustrated list of manufactured items ..... Appendix E

Image intensifier

    Inspection criteria for proper image intensifier operation ..... 2-8

    Installation ..... 3-14

    Configuration ..... 1-11

    Removal ..... 3-14

    Shipping ..... 3-21

Infinity focus adjustment ..... 3-13

Installation ..... 2-6

Interpupillary distance ..... 1-13

IR illumination ..... 1-15

IR Spot/Flood ..... 1-10, 2-11

**K**

Knob

    Installation ..... 2-17

    Power switch ..... 2-17

    Removal ..... 2-17

**L**

LED ..... 1-14

Lens cap ..... 2-11

LIF ..... 1-10

Location and description of major components ..... 1-10

Low light resolution test ..... 2-10, 3-9

Lubrication requirements ..... 2-20



# TM 11-5855-262-23&P-2

Subject ..... Para

## M

MTOE .....	3-1
Magnet, Metal Helmet Mount	
Installation .....	2-18
Removal .....	2-18
Maintenance	
Allocation Chart (MAC) .....	2-2, Appendix B
Forms, records, and reports .....	1-2, Appendix A
Major components, location and description .....	1-10
Manufactured items, illustrated list of .....	Appendix E
Mechanical Data .....	1-12
Mechanical functions .....	1-13

## N

Neck cord .....	2-11
Neck pad	
Installation .....	2-14
Removal .....	2-14
Nomenclature .....	1-5

## O

Objective lens	
Focus .....	1-12
Infinity Focus Adjustment .....	3-13
Installation .....	3-12, 1-12
Operation .....	1-14
Removal .....	3-12
Operating temperature .....	1-12
Operational checks .....	3-19
Operator adjustment limits .....	1-12
Optical functions .....	1-14

## P, Q

Packing .....	2-21, 3-20
PMCS table .....	2-7
Power	
source .....	1-15
switch .....	1-15
Preparation for storage or shipment .....	1-4
Preparation for using TS-3895A/UV .....	3-8
Purging .....	3-18

Subject ..... Para

R

Rear cover

- Installation..... 3-17
- Removal..... 3-17

References ..... Appendix A

Refinishing (See Repainting)

Repainting and refinishing requirements ..... 2-19

Repair parts ..... 2-3, 3-3

Reporting equipment improvement recommendation ..... 1-6

RPSTL..... Appendix C

Resolution check using the TS-4348/UV test set ..... 2-10

Resolution testing using the TS-3895A/UV ..... 3-9

S

Scope ..... 1-1, 3-6

Service upon receipt of materiel..... 2-5, 3-5

Site and shelter requirements ..... 2-4, 3-4

Shipment, preparation for ..... 3-21

Shipping and storage case ..... 1-10, 1-12

Special tools, TMDE, and support equipment ..... 2-2, 3-2, Appendix C

Storage, preparation for ..... 2-21

Storage temperature ..... 1-12

Switch ..... 1-15

T, U, V

Temperature limits ..... 1-12

Test Set

- TS-3895A/UV ..... 3-8, 3-9
- TS-4348/UV ..... 2-10

Tools

- Common ..... Appendix B
- Special ..... Appendix C

Troubleshooting

- Direct Support ..... 3-7
- Electrical ..... 3-10
- Table..... 3-7
- Unit ..... 2-9

W, X, Y, Z

Warranty information ..... 1-7

Weight

- Goggles ..... 1-12
- Shipping and storage case..... 1-12

Wired housing

- Installation..... 3-16
- Removal..... 3-16

By Order of the Secretary of the Army:

ERIC K. SHINSEKI  
*General, United States Army*  
*Chief of Staff*

Official:

  
JOEL B. HUDSON  
Administrative Assistant to the  
Secretary of the Army  
0017902

By Order of the Secretary of the Navy:

WALTER H. CANTRELL  
Rear Admiral, United States Navy  
*Commander, Space and Naval Warfare*  
*Systems Command*

By Order of the Secretary of the Marine Corps:

RANDALL P. SHOCKEY  
Director, Program Support  
*Marine Corps Systems Command*

By Order of the Secretary of the Air Force:

MICHAEL E. RYAN  
*General, United States Air Force*  
*Chief of Staff*

Official:

GEORGE T. BABBITT  
General, United States Air Force  
Commander, AFMC

DISTRIBUTION:

To be distributed in accordance with the initial distribution number (IDN)  
369350 requirements for TM 11-5855-262-23&P-2.

RECOMMENDED CHANGES TO EQUIPMENT TECHNICAL PUBLICATIONS



THEN ... JOT DOWN THE DOPE ABOUT IT ON THIS FORM. CAREFULLY TEAR IT OUT. FOLD IT AND DROP IT IN THE MAIL.

FROM: (PRINT YOUR UNIT'S COMPLETE ADDRESS)  
 Commander  
 Stateside Army Depot  
 ATTN: AMSTA-US  
 Stateside, N.J. 07703-5007

DATE SENT: 10 July 1975

PUBLICATION NUMBER TM 11-5840-340-20P	PUBLICATION DATE 23 Jan 74	PUBLICATION TITLE Radar Set AN/PRC-76
--	-------------------------------	--

BE EXACT PIN-POINT WHERE IT IS				IN THIS SPACE TELL WHAT IS WRONG AND WHAT SHOULD BE DONE ABOUT IT:
PAGE NO	PARA-GRAPH	FIGURE NO	TABLE NO	
2-25	2-28			<p>Recommend that the installation antenna alignment procedure be changed throughout to specify a 2<sup>0</sup> IFF antenna lag rather than 1<sup>0</sup>.</p> <p>REASON: Experience has shown that with only a 1<sup>0</sup> lag, the antenna servo system is too sensitive to wind gusting in excess of 25 knots, and has a tendency to rapidly accelerate and decelerate as it hunts, causing strain to the drive train. Hunting is minimized by adjusting the lag to 2<sup>0</sup> without degradation of operation.</p>
3-10	3-3		3-1	<p>Item 5, Functional Column. Change "2 dB" to "3 dB".</p> <p>REASON: The adjustment procedure for the TRANS POWER FAULT indicator calls for a 3 dB (500 watts) adjustment to light the TRANS POWER FAULT indicator.</p>
5-6	5-8			<p>and new step f.1 to read, "Replace cover plate removed in step above."</p> <p>REASON: To replace the cover plate.</p>
		FO-3		<p>Zone C 3. On J1-2, change "+24 VDC" to "+5 VDC".</p> <p>REASON: This is the output line of the 5 VDC power supply. +24 VDC is the input voltage.</p>

PRINTED NAME, GRADE OR TITLE AND TELEPHONE NUMBER

SSG I. M. DeSpirito 999-1776

SIGN HERE



RECOMMENDED CHANGES TO EQUIPMENT TECHNICAL PUBLICATIONS



THEN ... JOT DOWN THE DOPE ABOUT IT ON THIS FORM. CAREFULLY TEAR IT OUT. FOLD IT AND DROP IT IN THE MAIL.

**SOMETHING WRONG WITH THIS PUBLICATION**

FROM: (PRINT YOUR UNIT'S COMPLETE ADDRESS)

DATE SENT

PUBLICATION NUMBER

PUBLICATION DATE

PUBLICATION TITLE

BE EXACT PIN-POINT WHERE IT IS

IN THIS SPACE TELL WHAT IS WRONG AND WHAT SHOULD BE DONE ABOUT IT:

PAGE NO

PARA-GRAPH

FIGURE NO

TABLE NO

.....  
DOTTED LINE

.....  
TEAR A

PRINTED NAME, GRADE OR TITLE AND TELEPHONE NUMBER

SIGN HERE

**DA** FORM 2028-2  
1 JUL 79

PREVIOUS EDITIONS ARE OBSOLETE

P.S. - IF YOUR OUTFIT WANTS TO KNOW ABOUT YOUR RECOMMENDATION MAKE A CARBON COPY OF THIS AND GIVE IT TO YOUR HEADQUARTERS.

REVERSE OF DA FORM 2028-2

FILL IN YOUR  
UNIT'S ADDRESS

FOLD BACK

DEPARTMENT OF THE ARMY

---

---

OFFICIAL BUSINESS

PLEASE  
AFFIX  
STAMP  
POSTAGE  
REQUIRED

Commander  
US Army Communications-Electronics Command  
and Fort Monmouth  
ATTN: AMSEL-LC-LEO-P-MM-T  
Fort Monmouth, New Jersey 07703-5007

TEAR ALONG DOTTED LINE

# THE METRIC SYSTEM AND EQUIVALENTS

## WEIGHT MEASURE

1 Centimeter = 10 Millimeters = 0.01 Meters = 0.3937 Inches  
 1 Meter = 100 Centimeters = 1000 Millimeters = 39.37 Inches  
 1 Kilometer = 1000 Meters = 0.621 Miles

## WEIGHTS

1 Gram = 0.001 Kilograms = 1000 Milligrams = 0.035 Ounces  
 1 Kilogram = 1000 Grams = 2.2 lb.  
 1 Metric Ton = 1000 Kilograms = 1 Megagram = 1.1 Short Tons

## LIQUID MEASURE

1 Milliliter = 0.001 Liters = 0.0338 Fluid Ounces  
 1 Liter = 1000 Milliliters = 33.82 Fluid Ounces

## SQUARE MEASURE

1 Sq. Centimeter = 100 Sq. Millimeters = 0.155 Sq. Inches  
 1 Sq. Meter = 10,000 Sq. Centimeters = 10.76 Sq. Feet  
 1 Sq. Kilometer = 1,000,000 Sq. Meters = 0.386 Sq. Miles

## CUBIC MEASURE

1 Cu. Centimeter = 1000 Cu. Millimeters = 0.06 Cu. Inches  
 1 Cu. Meter = 1,000,000 Cu. Centimeters = 35.31 Cu. Feet

## TEMPERATURE

$5/9(^{\circ}\text{F} - 32) = ^{\circ}\text{C}$   
 212° Fahrenheit is equivalent to 100° Celsius  
 90° Fahrenheit is equivalent to 32.2° Celsius  
 32° Fahrenheit is equivalent to 0° Celsius  
 $9/5^{\circ}\text{C} + 32 = ^{\circ}\text{F}$

## APPROXIMATE CONVERSION FACTORS

TO CHANGE	TO	MULTIPLY BY
Inches	Centimeters	2.540
Feet	Meters	0.305
Yards	Meters	0.914
Miles	Kilometers	1.609
Square Inches	Square Centimeters	6.451
Square Feet	Square Meters	0.093
Square Yards	Square Meters	0.836
Square Miles	Square Kilometers	2.590
Acres	Square Hectometers	0.405
Cubic Feet	Cubic Meters	0.028
Cubic Yards	Cubic Meters	0.765
Fluid Ounces	Milliliters	29.573
its	Liters	0.473
arts	Liters	0.946
allons	Liters	3.785
Ounces	Grams	28.349
Pounds	Kilograms	0.454
Short Tons	Metric Tons	0.907
Pound-Feet	Newton-Meters	1.356
Pounds per Square Inch	Kilopascals	6.895
Miles per Gallon	Kilometers per Liter	0.425
Miles per Hour	Kilometers per Hour	1.609

TO CHANGE	TO	MULTIPLY BY
Centimeters	Inches	0.394
Meters	Feet	3.280
Meters	Yards	1.094
Kilometers	Miles	0.621
Square Centimeters	Square Inches	0.155
Square Meters	Square Feet	10.764
Square Meters	Square Yards	1.196
Square Kilometers	Square Miles	0.386
Square Hectometers	Acres	2.471
Cubic Meters	Cubic Feet	35.315
Cubic Meters	Cubic Yards	1.308
Milliliters	Fluid Ounces	0.034
Liters	Pints	2.113
Liters	Quarts	1.057
ers	Gallons	0.264
ms	Ounces	0.035
ograms	Pounds	2.205
Metric Tons	Short Tons	1.102
Newton-Meters	Pounds-Feet	0.738
Kilopascals	Pounds per Square Inch	0.145
ometers per Liter	Miles per Gallon	2.354
ometers per Hour	Miles per Hour	0.621

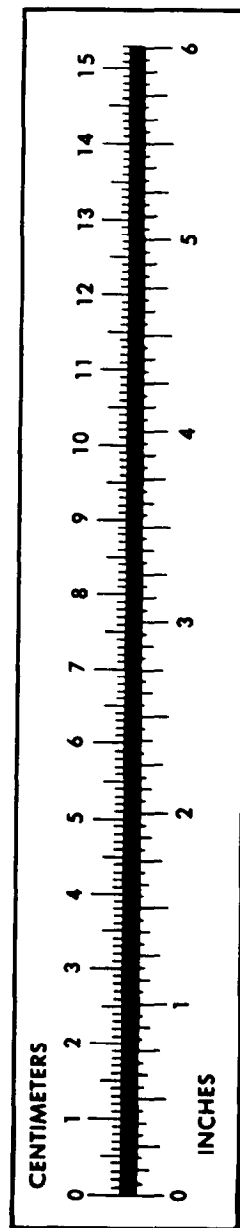

**PIN: 070424-000**