

Genie Industries



Genie[®]Z-25/8[™]

Genie[®]Z-20/8[™]

Genie[®]Z-20/8[™] **N**

Service Manual

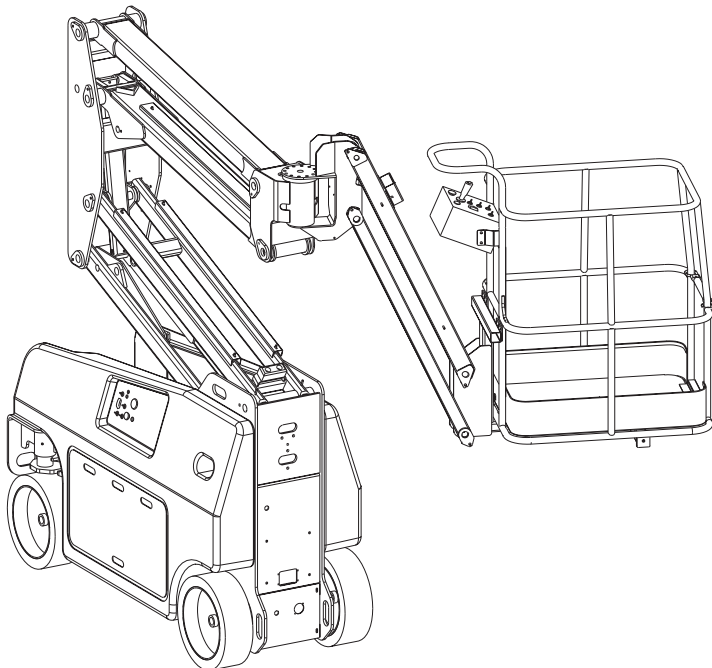

First Edition • Third Printing
Part No. 41314



Genie[®] Z-25/8[™]

Genie[®] Z-20/8[™]

Genie[®] Z-20/8[™] **N**

Important

Read, understand and obey the safety rules and operating instructions in the *Genie Z-25/8 & Genie Z-20/8 & Genie Z-20/8N Operator's Manual* before attempting any maintenance or repair procedure.

This manual provides detailed scheduled maintenance information for the machine owner and user. It also provides troubleshooting and repair procedures for qualified service professionals.

Basic mechanical, hydraulic and electrical skills are required to perform most procedures. However, several procedures require specialized skills, tools, lifting equipment and a suitable workshop. In these instances, we strongly recommend that maintenance and repair be performed at an authorized Genie dealer service center.

Genie Industries has endeavored to deliver the highest degree of accuracy possible. However, continuous improvement of our products is a Genie policy. Therefore product specifications are subject to change without notice.

Readers are encouraged to notify Genie of errors and send in suggestions for improvement. All communications will be carefully considered for future printings of this and other manuals. Please write to the technical publications team in care of Genie Industries, PO Box 97030, Redmond WA 98073-9730 USA.

If you have any questions, please call Genie Industries.

Contact us:

<http://www.genielift.com>
e-mail: techpub@genieind.com

Genie Industries

Copyright © 1997 by Genie Industries

First Edition: First Printing, September 1997
 Second Printing, February 1998
 Third Printing, April 2000

Genie and "Z" are registered trademarks of Genie Industries in the USA and many other countries.

 Printed on recycled paper

Printed in U.S.A.

Safety Rules



Danger

Failure to obey the instructions and safety rules in this manual and the *Genie Z-20/8N & Genie Z-20/8 & Genie Z-25/8 Operator's Manual* will result in death or serious injury.

Many of the hazards identified in the operator's manual are also safety hazards when maintenance and repair procedures are performed.

Do Not Perform Maintenance Unless:

- You are trained and qualified to perform maintenance on this machine.
- You read, understand and obey:
 - manufacturer's instructions and safety rules
 - employer's safety rules and worksite regulations
 - applicable governmental regulations
- You have the appropriate tools, lifting equipment and a suitable workshop.

SAFETY RULES

Personal Safety

Any person working on or around a machine must be aware of all known safety hazards. Personal safety and the continued safe operation of the machine should be your top priority.



Read each procedure thoroughly. This manual and the decals on the machine, use signal words to identify the following:



Safety alert symbol—used to alert personnel to potential personal injury hazards. Obey all safety messages that follow this symbol to avoid possible injury or death.



Red—used to indicate the presence of an imminently hazardous situation which, if not avoided, will result in death or serious injury.



Orange—used to indicate the presence of a potentially hazardous situation which, if not avoided, could result in death or serious injury.



Yellow with safety alert symbol—used to indicate the presence of a potentially hazardous situation which, if not avoided, may cause minor or moderate injury.



Yellow without safety alert symbol—used to indicate the presence of a potentially hazardous situation which, if not avoided, may result in property damage.



Indicates special operation or maintenance information.



Be sure to wear protective eye wear and other protective clothing if the situation warrants it.



Be aware of potential crushing hazards such as moving parts, free swinging or unsecured components when lifting or placing loads. Always wear approved steel-toed shoes.

Workplace Safety

Be sure to keep sparks, flames and lighted tobacco away from flammable and combustible materials like battery gases and engine fuels. Always have an approved fire extinguisher within easy reach.



Be sure that all tools and working areas are properly maintained and ready for use. Keep work surfaces clean and free of debris that could get into machine components and cause damage.



Be sure that your workshop or work area is properly ventilated and well lit.



Be sure any forklift, overhead crane or other lifting or supporting device is fully capable of supporting and stabilizing the weight to be lifted. Use only chains or straps that are in good condition and of ample capacity.



Be sure that fasteners intended for one time use (i.e., cotter pins and self-locking nuts) are not re-used. These components may fail if they are used a second time.



Be sure to properly dispose of old oil or other fluids. Use an approved container. Please be environmentally safe.

Theory of Operation

Power Source

The Genie Z-20/8N & Genie Z-20/8 & Genie Z-25/8 machines are powered by eight six-volt (255 AH) batteries. Each 4-battery pack, is wired in series/parallel to produce 24V DC. The two battery packs are then wired in series to produce 48V DC. The drive system uses 48V DC and the control system uses 24V DC.

Hydraulic System

All machine functions are performed by the hydraulic system. The hydraulic system is powered by a two-section pressure balanced gear pump. The lift and steer functions use pump #2. The drive function utilizes pump #1 combined with pump #2 for a total of 12 cc's displacement per revolution. To protect from over-pressurization of the hydraulic system, the pumps are provided with a pressure relief valve set at 3500 psi (241 bar).

Activating a machine function is accomplished by actuating or moving a toggle switch and/or control handle, which sends voltage to the appropriate directional control valve. The directional control valve determines which direction the hydraulic fluid will travel. The amount of hydraulic fluid volume is determined by the proportional valve input voltage from the boom function speed controller at the platform controls. The boom lift cylinder and the jib boom lift cylinder incorporate counterbalance valves to prevent movement in the event of a hydraulic line failure.

Electrical System

Drive speed limit switch

The drive speed limit switch, located in the boom storage area, is used to restrict drive speed when the boom is raised. An improperly functioning drive speed limit switch will allow the boom to raise and/or drive into an unsafe position.

Machine Controls

The Genie Z-20/8N & Genie Z-20/8 & Genie Z-25/8 machines are equipped with operational controls which are found in two locations: the ground controls, and platform controls. All lift and drive functions are available at the platform controls. Only boom functions are available at the ground controls. Moving a boom toggle switch in the direction indicated on the control panel decal will indicate which boom function will operate and its direction of travel.

The platform controls incorporates a boom function speed controller which, by varying the position of the controller, controls the amount of voltage sent to the proportional valve. This determines the speed at which the function will operate.

The drive controller (joystick) is fitted with a potentiometer that communicates the joystick position with the motor controller. A thumb rocker switch on the top of the joystick is used for steering.

Washing electronic components is not suggested. Instead, use compressed air to remove debris from these components.

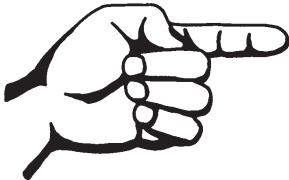

This page intentionally left blank.

Table of Contents

Introduction

Important Information	<i>ii</i>
-----------------------------	-----------

Section One Safety Rules

General Safety Rules	<i>iii</i>
Theory Of Operation	v

Section Two Specifications

Machine and Performance Specifications, Z-25/8 Models	2 - 1
Machine and Performance Specifications, Z-20/8 Models	2 - 2
Machine and Performance Specifications, Z-20/8N Models	2 - 3
Hydraulic Specifications - All Models	2 - 4
Hydraulic Hose and Fitting Torque Specifications	2 - 5

Section Three Scheduled Maintenance Inspections

Introduction	3 - 1
Table A	3 - 2
Table B	3 - 2
Table C	3 - 3
Table D	3 - 3
Maintenance Inspection Report	3 - 4

Section Four Scheduled Maintenance Procedures

Introduction	4 - 1
A-1 Inspect the Operator's and Safety Manuals	4 - 2
A-2 Inspect the Decals and Placards	4 - 2
A-3 Inspect for Damage and Loose or Missing Parts	4 - 3
A-4 Check the Hydraulic Oil Level	4 - 3

 TABLE OF CONTENTS

Section Four	Scheduled Maintenance Procedures, continued	
A-5	Check for Hydraulic Leaks	4 - 4
A-6	Test the Platform and Ground Controls	4 - 5
A-7	Test the Auxiliary Power Operation	4 - 6
A-8	Test the Tilt Sensor	4 - 6
A-9	Test the Drive Speed Limit Switch	4 - 7
A-10	Perform 30 Day Service	4 - 9
B-1	Check the Batteries	4 - 10
B-2	Inspect the Electrical Wiring	4 - 11
B-3	Inspect the Tires and Wheels (including castle nut torque)	4 - 12
B-4	Test the Key Switch	4 - 12
B-5	Test the Emergency Stop Buttons	4 - 13
B-6	Test the Ground Control Override	4 - 13
B-7	Test the Horn	4 - 14
B-8	Test the Foot Switch	4 - 14
B-9	Test the Drive Brakes	4 - 15
B-10	Test the Drive Speed - Stowed Position	4 - 16
B-11	Test the Drive Speed - Raised Position	4 - 17
B-12	Test the Alarm Package (if equipped)	4 - 18
B-13	Perform Hydraulic Oil Analysis	4 - 19
B-14	Check the Electrical Contactors	4 - 19
B-15	Replace the Hydraulic Tank Return Filter	4 - 19
C-1	Bleed the Jib Boom Rotator	4 - 21
D-1	Test or Replace the Hydraulic Oil	4 - 22

Section Five	Troubleshooting Flow Charts	
	Introduction	5 - 1
1	All Functions Will Not Operate	5 - 3
2	Pump Motor Will Not Operate	5 - 6
3	Auxiliary Functions Inoperative	5 - 8
4	All Functions Inoperative, Power Unit Starts and Runs	5 - 10
5	Ground Controls Inoperative, Platform Controls Operate Normally	5 - 11
6	Platform Controls Inoperative, Ground Controls Operate Normally	5 - 12
7	Boom Up Function Inoperative	5 - 15
8	Boom Down Function Inoperative	5 - 17
9	Jib Boom Up Function Inoperative	5 - 19
10	Jib Boom Down Function Inoperative	5 - 22
11	Jib Boom Rotate Left Function Inoperative	5 - 25
12	Jib Boom Rotate Right Function Inoperative	5 - 28
13	Steer Left Function Inoperative	5 - 31
14	Steer Right Function Inoperative	5 - 32
15	All Drive Functions Inoperative, All Other Functions Operate Normally	5 - 33
16	Drive Forward Function Inoperative	5 - 36
17	Drive Reverse Function Inoperative	5 - 37
18	Machine Will Not Drive At Full Speed	5 - 38
19	Machine Drives At Full Speed With Platform Raised	5 - 41
20	Brake Release Function Inoperative	5 - 42

TABLE OF CONTENTS

Section Six	Schematics	
	Introduction	6 - 1
	Electrical Components	6 - 2
	Electrical Symbols Legend	6 - 4
	Abbreviation Legend	6 - 5
	Electrical Schematic, Z-25/8 (before serial number 229) Z-20/8 (before serial number 125) Z-20/8N (before serial number 968)	6 - 7
	Electrical Schematic, Z-25/8 (after serial number 228) Z-20/8 (after serial number 124) Z-20/8N (after serial number 967)	6 - 8
	Ground Control Panel Wiring Diagram	6 - 9
	Platform Control Box Wiring Diagram, Z-25/8 (before serial number 229) Z-20/8 (before serial number 125) Z-20/8N (before serial number 968)	6 - 10
	Platform Control Box Wiring Diagram, Z-25/8 (after serial number 228) Z-20/8 (after serial number 124) Z-20/8N (after serial number 967)	6 - 11
	Power Cable Diagram	6 - 12
	Hydraulic Symbols Legend	6 - 14
	Hydraulic Schematic, Z-25/8 (before serial number 229) Z-20/8 (before serial number 125) Z-20/8N (before serial number 968)	6 - 15
	Hydraulic Schematic, Z-25/8 (after serial number 228) Z-20/8 (after serial number 124) Z-20/8N (after serial number 967)	6 - 16

Section Seven	Repair Procedures	
	Introduction	7 - 1
	Platform Controls	
1-1	Joystick Controller	7 - 2
1-2	Foot Switch	7 - 5
1-3	Toggle Switches	7 - 6
1-4	Control Relays	7 - 7
	Platform Components	
2-1	Platform	7 - 9
	Jib Boom Components	
3-1	Jib Boom	7 - 10
3-2	Jib Boom Cylinder	7 - 12
3-3	Jib Boom Rotator	7 - 13
	Boom Components	
4-1	Boom	7 - 17
4-2	Boom Lift Cylinder	7 - 21
	Ground Controls	
5-1	Toggle Switches, See 1-3, <i>Toggle Switches</i>	7 - 6
5-2	Control Relays, See 1-4, <i>Control Relays</i>	7 - 7
5-3	Wago® Components	7 - 22

TABLE OF CONTENTS

Section Seven Repair Procedures, continued

Hydraulic Pumps

6-1 Auxiliary Pump 7 - 23
 6-2 Main Function Pump 7 - 24

Manifolds

7-1 Function Manifold Components 7 - 26
 7-2 Valve Adjustments - Function Manifold..... 7 - 28
 7-3 Jib Boom and Jib Boom Rotate Manifold Components 7 - 30
 7-4 Brake Release Hand Pump Components 7 - 31

Steering Axle Components

8-1 Yoke and Drive Motor 7 - 32
 8-2 Steering Cylinder 7 - 34
 8-3 Steering Bellcrank 7 - 35

Non-steering Axle Components

9-1 Drive Brake 7 - 37

Specifications

Machine Specifications Z-25/8 Models

Stowed dimensions

Length	16 ft	4.9 m
Width	46 in	1.2 m
Height	79 in	2 m
Ground clearance, at machine center	5 in	12.7 cm
at pothole bars	2 in	5.1 cm

Operational dimensions

Maximum platform height	25 ft	7.6 m
Maximum platform working height	31 ft	9.4 m
Maximum horizontal reach	7 ft 11 in	2.4 m
Tailswing	18 in	45.7 cm
Noseswing	58 in	147.3 cm
Wheelbase	5 ft 4 in	1.6 m
Minimum turning circle, outside	12 ft 7 in	3.8 m
Minimum turning circle, inside	22 in	56 cm
Jib boom rotation		180°
Jib boom range of motion		144°

Platform dimensions

Length	30 in	76.2 cm
Width	46 in	116.8 cm
Maximum load capacity	500 lbs	227 kg

Fluid capacities

Hydraulic tank capacity	8 gallons	30.3 liters
Hydraulic system capacity (including tank)	10 gallons	37.9 liters

Tires and wheels

Tire size (solid rubber)	18 x 14 x 6 in 46 x 36 x 15 cm	
Tire contact area	5.8 sq in	37.4 sq cm
Load range	3200 lbs	1873 Nm
Overall tire diameter	18 in	46 cm
Wheel diameter	14 in	36 cm
Wheel width	6 in	15 cm
Castle nut torque	300 ft-lbs	407 Nm
Gradeability (boom stowed)	20%	

Performance Specifications Z-25/8 Models

Drive speeds, maximum

Boom stowed, high range	2.7 mph 40 ft/11 sec	4.3 km/h 12.2 m/11 sec
Boom stowed, low range	1.4 mph 40 ft/27.3 sec	2.25 km/h 12.2 m/27 sec
Boom raised	0.6 mph 40 ft/52 sec	0.8 km/h 12.2 m/52 sec

Boom function speeds, maximum from platform controls

Elevate up	27 to 33 seconds
Elevate down	32 to 38 seconds
Jib boom up	27 to 33 seconds
Jib boom down	17 to 23 seconds
Jib rotate, 180°	28 to 34 seconds

Continuous improvement of our products is a Genie policy. Product specifications are subject to change without notice.

SPECIFICATIONS

Machine Specifications Z-20/8 Models

Stowed dimensions

Length	11 ft 9 in	3.6 m
Width	46 in	1.2 m
Height	79 in	2 m
Ground clearance, at machine center	5 in	12.7 cm
at pothole bars	2 in	5.1 cm

Operational dimensions

Maximum platform height	20 ft	6.1 m
Maximum platform working height	26 ft	7.9 m
Maximum horizontal reach	7 ft 11 in	2.4 m
Tailswing	0 in	0 cm
Noseswing	0 in	0 cm
Wheelbase	5 ft 4 in	1.6 m
Minimum turning circle, outside	12 ft 7 in	3.8 m
Minimum turning circle, inside	22 in	56 cm
Jib boom rotation		180°
Jib boom range of motion		144°

Platform dimensions

Length	30 in	76.2 cm
Width	46 in	116.8 cm
Maximum load capacity	500 lbs	227 kg

Fluid capacities

Hydraulic tank capacity	8 gallons	30.3 liters
Hydraulic system capacity (including tank)	10 gallons	37.9 liters

Tires and wheels

Tire size (solid rubber)	18 x 14 x 6 in 46 x 36 x 15 cm	
Tire contact area	5.8 sq in	37.4 sq cm
Load range	3200 lbs	1873 Nm
Overall tire diameter	18 in	46 cm
Wheel diameter	14 in	36 cm
Wheel width	6 in	15 cm
Castle nut torque	300 ft-lbs	407 Nm
Gradeability (boom stowed)	20%	

Performance Specifications Z-20/8 Models

Drive speeds, maximum

Boom stowed, high range	2.7 mph 40 ft/11 sec	4 km/h 12.2 m/11 sec
Boom stowed, low range	1.4 mph 40 ft/27.3 sec	1.6 km/h 12.2 m/27 sec
Boom raised	0.6 mph 40 ft/52 sec	0.8 km/h 12.2 m/52 sec

Boom function speeds, maximum from platform controls

Elevate up	14 to 20 seconds
Elevate down	14 to 20 seconds
Jib boom up	27 to 33 seconds
Jib boom down	17 to 23 seconds
Jib rotate, 180°	28 to 34 seconds

Continuous improvement of our products is a Genie policy. Product specifications are subject to change without notice.

SPECIFICATIONS

Machine Specifications Z-20/8N Models

Stowed dimensions

Length	12 ft 4 in	3.8 m
Width	32 in	81.3 cm
Height	79 in	2 m
Ground clearance, at machine center	5 in	12.7 cm
at pothole bars	1.625 in	4.1 cm

Operational dimensions

Maximum platform height	20 ft	6.1 m
Maximum platform working height	26 ft	7.9 m
Maximum horizontal reach	8 ft 8 in	2.6 m
Tailswing	0 in	0 cm
Noseswing	0 in	0 cm
Wheelbase	5 ft 4 in	1.9 m
Minimum turning circle, outside	9 ft 6 in	2.9 m
Minimum turning circle, inside	20 in	51 cm
Jib boom rotation		180°
Jib boom range of motion		144°

Platform dimensions

Length	31 in	79 cm
Width	40 in	102 cm
Maximum load capacity, ANSI & CSA	400 lbs	181 kg
CE	440 lbs	200 kg

Fluid capacities

Hydraulic tank capacity	8 gallons	30.3 liters
Hydraulic system capacity (including tank)	10 gallons	37.9 liters

Tires and wheels

Tire size (solid rubber)	18 x 14 x 6 in 46 x 36 x 15 cm	
Tire contact area	5.8 sq in	37.4 sq cm
Load range	3200 lbs	1873 Nm
Overall tire diameter	18 in	46 cm
Wheel diameter	14 in	36 cm
Wheel width	6 in	15 cm
Castle nut torque	300 ft-lbs	407 Nm

Gradeability (boom stowed) 18%

Continuous improvement of our products is a Genie policy. Product specifications are subject to change without notice.

Performance Specifications Z-20/8N Models

Drive speeds, maximum

Boom stowed, high range	2.6 mph 40 ft/11 sec	4 km/h 12.2 m/11 sec
Boom stowed, low range	1.3 mph 40 ft/27.3 sec	1.6 km/h 12.2 m/27 sec
Boom raised	0.6 mph 40 ft/52 sec	0.8 km/h 12.2 m/52 sec

Boom function speeds, maximum from platform controls

Elevate up	14 to 20 seconds
Elevate down	14 to 20 seconds
Jib boom up	27 to 33 seconds
Jib boom down	17 to 23 seconds
Jib rotate, 180°	28 to 34 seconds

SPECIFICATIONS

Hydraulic Specifications All Models

Hydraulic fluid	Dexron equivalent
------------------------	-------------------

Lift/Drive pump

Z-25/8 before serial number 212

Z-20/8 before serial number 122

Z-20/8N before serial number 896:

Type:	2 section pressure balanced gear pump
-------	---------------------------------------

Displacement per revolution (pump #1)	0.37 cu in 6 cc
--	--------------------

Displacement (2500 psi/172 bar)	2 gallons per minute 7.6 liters per minute
------------------------------------	---

Displacement per revolution (pump #2)	0.37 cu in 6 cc
--	--------------------

Displacement (2500 psi/172 bar)	2 gallons per minute 7.6 liters per minute
------------------------------------	---

Lift/Drive pump

Z-25/8 after serial number 211

Z-20/8 after serial number 121

Z-20/8N after serial number 895:

Type:	2 section pressure balanced gear pump
-------	---------------------------------------

Displacement per revolution (pump #1)	0.488 cu in 8 cc
--	---------------------

Displacement (2500 psi/172 bar)	4 gallons per minute 15.2 liters per minute
------------------------------------	--

Displacement per revolution (pump #2)	0.25 cu in 4 cc
--	--------------------

Displacement (2500 psi/172 bar)	1.6 gallons per minute 6.05 liters per minute
------------------------------------	--

Auxiliary pump

Type	fixed displacement gear pump
------	------------------------------

Displacement	0.6 gpm 2.3 liters/minute
--------------	------------------------------

Auxiliary pump relief pressure	3200 psi 221 bar
-----------------------------------	---------------------

Drive motors

Displacement per revolution	22.8 cu in 374 cc
-----------------------------	----------------------

Function manifold

Steering relief valve pressure	2500 psi 172 bar
-----------------------------------	---------------------

Boom down relief valve pressure	1500 psi 103 bar
------------------------------------	---------------------

System relief valve pressure	3500 psi 241 bar
---------------------------------	---------------------

SPECIFICATIONS

Hydraulic Hose and Fitting Torque Specifications

Your machine is equipped with either 37° flared fittings and hose ends OR Parker Seal-Lok® fittings and hose ends. Machines that utilize Parker Seal-Lok® hoses and fittings require that the fittings and hose ends be torqued to specification when they are removed and installed or when new hoses or fittings are installed. Machines equipped with 37° flared fittings and hose ends do not need to be torqued to these specifications.

Hydraulic Hose and Fitting Torque Specifications						
SAE O-ring Boss Port - tube fitting				Seal-Lok® - hose end		
SAE Dash Size	Installing into...	ft. lbs.	Nm	SAE Dash Size	ft. lbs.	Nm
-4	Aluminum	11	14.9	-4	18	24.4
	Steel	16	21.7	-6	27	36.6
-6	Aluminum	23	31.2	-8	40	54.2
	Steel	35	47.5	-10	63	85.4
-8	Aluminum	40	54.2	-12	90	122
	Steel	60	81.3	-16	120	162.7
-10	Aluminum	69	93.6	-20	140	190
	Steel	105	142.4	-24	165	223.7
-12	Aluminum	93	126.1			
	Steel	140	190			
-16	Aluminum	139	188.5			
	Steel	210	284.7			
-20	Aluminum	172	233.2			
	Steel	260	352.5			
-24	Aluminum	208	282			
	Steel	315	427.1			

Torque Procedure

- 1 Replace the O-ring. The O-ring must be replaced anytime the seal has been broken. The O-ring cannot be re-used if the fitting or hose end has been tightened beyond finger tight.
- 2 Lubricate the O-ring before installation.
- 3 Be sure that the face seal O-ring is seated and retained properly.
- 4 Position the tube and nut squarely on the face seal end of the fitting and tighten the nut finger tight.
- 5 Tighten the nut or fitting to the appropriate torque per given size as shown in the table above.
- 6 Operate all machine functions and inspect the hoses and fittings and related components to be sure that there are no leaks.

NOTICE The O-rings used in the Parker Seal Lok® fittings and hose ends are a custom-size O-ring. They are not a standard SAE size O-ring. They are available in the O-ring field service kit (Genie part number 49612).

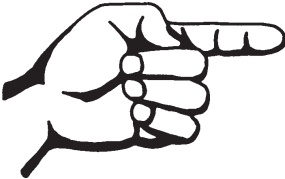

This page intentionally left blank.

Scheduled Maintenance Inspections



Observe and Obey:

- ☑ Maintenance inspections shall be completed by a person trained and qualified on the maintenance of this machine.
- ☑ Scheduled maintenance inspections shall be completed daily, quarterly, annually and every 2 years as specified on the *Maintenance Inspection Report*.

⚠WARNING Failure to properly complete each inspection when required may cause death, serious injury or substantial machine damage.

- ☑ Immediately tag and remove from service a damaged or malfunctioning machine.
- ☑ Repair any machine damage or malfunction before operating machine.
- ☑ Keep records on all inspections for three years.
- ☑ Machines that have been out of service for a period longer than 3 months must complete the quarterly inspection.

About This Section

The Schedule

There are four types of maintenance inspections that must be performed according to a schedule—daily, quarterly, annual and two year. To account for repeated procedures, the *Maintenance Tables* and the *Maintenance Inspection Report* have been divided into four subsections—A, B, C, D. Use the following chart to determine which group(s) of procedures are required to perform a scheduled inspection.

Inspection	Table or Checklist
Daily	A
Quarterly	A + B
Annual	A + B + C
Two year	A + B + C + D

Maintenance Tables

The maintenance tables contained in this section provide summary information on the specific physical requirements for each inspection.

Complete step-by-step instructions for each scheduled maintenance procedure are provided in section 4, *Scheduled Maintenance Procedures*.

Maintenance Inspection Report

The maintenance inspection report contains checklists for each type of scheduled inspection.

Make copies of the *Maintenance Inspection Report* to use for each inspection. Store completed forms for three years.

Maintenance Tables

Table A











		Tools are required	New parts required	Dealer service suggested
A-1	Inspect the Operator's and Safety Manuals			
A-2	Inspect the Decals and Placards			
A-3	Inspect for Damage and Loose or Missing Parts			
A-4	Check the Hydraulic Oil Level			
A-5	Check for Hydraulic Leaks			
A-6	Test the Platform and Ground Controls			
A-7	Test the Auxiliary Power Operation			
A-8	Test the Tilt Sensor			
A-9	Test the Drive Speed Limit Switch			
A-10	Perform 30 Day Service			

Table B

B-1	Check the Batteries			
B-2	Inspect the Electrical Wiring			
B-3	Inspect the Tires and Wheels (including castle nut torque)			
B-4	Test the Key Switch			
B-5	Test the Emergency Stop Buttons			
B-6	Test the Ground Control Override			

MAINTENANCE TABLES

Table B, continued









		Tools are required	New parts required	Dealer service suggested
B-7	Test the Horn			
B-8	Test the Foot Switch			
B-9	Test the Drive Brakes			
B-10	Test the Drive Speed - Stowed Position			
B-11	Test the Drive Speed - Raised Position			
B-12	Test the Alarm Package - Optional Equipment			
B-13	Perform Hydraulic Oil Analysis See D-1 <i>Test or Replace the Hydraulic Oil</i>			
B-14	Check the Electrical Contactors			
B-15	Replace the Hydraulic Return Filter			

Table C

C-1	Bleed the Jib Boom Rotator			
-----	----------------------------	---	--	--

Table D

D-1	Test or Replace the Hydraulic Oil			
-----	-----------------------------------	---	--	---

Maintenance Inspection Report

Model _____

Serial number _____

Date _____

Hour meter _____

Machine owner _____

Inspected by (print) _____

Inspector signature _____

Inspector title _____

Inspector company _____

Instructions

- Make copies of this page to use for each inspection.
- Select the appropriate checklist(s) for the type of inspection to be performed.

- Daily Inspection: A**
- Quarterly Inspection: A+B**
- Annual Inspection: A+B+C**
- 2 Year Inspection: A+B+C+D**

- Place a check in the appropriate box after each inspection procedure is completed.
- Use the maintenance tables in this section and the step-by-step procedures in section 4 to learn how to perform these inspections.
- If any inspection receives an "N", tag and remove the machine from service, repair and re-inspect it. After repair, place a check in the "R" box.

Legend

- Y = yes, acceptable
- N = no, remove from service
- R = repaired

Comments _____

Checklist A	Y	N	R
Refer to Table A			
A-1 Operator's and Safety manuals			
A-2 Decals and placards			
A-3 Inspect for Damage, loose or missing parts			
A-4 Hydraulic oil level			
A-5 Hydraulic leaks			
A-6 Platform and ground controls			
A-7 Auxiliary power			
A-8 Tilt sensor			
A-9 Drive Speed Limit switch			
A-10 30 Day Service			

Checklist B	Y	N	R
Refer to Table B			
B-1 Batteries			
B-2 Electrical wiring			
B-3 Tires and wheels			
B-4 Key Switch			
B-5 Emergency Stop			
B-6 Ground control override			
B-7 Horn			
B-8 Foot switch			
B-9 Drive brakes			
B-10 Drive speed - stowed			
B-11 Drive Speed - raised			
B-12 Alarm package			
B-13 Hydraulic oil analysis			
B-14 Electrical contactors			
B-15 Hydraulic tank return filter			

Checklist C	Y	N	R
Refer to Table C			
C-1 Jib boom rotator			

Checklist D	Y	N	R
Refer to Table D			
D-1 Hydraulic oil			

Scheduled Maintenance Procedures



Observe and Obey:

- ☑ Maintenance inspections shall be completed by a person trained and qualified on the maintenance of this machine.
- ☑ Scheduled maintenance inspections shall be completed daily, quarterly, annually and every 2 years as specified on the *Maintenance Inspection Report*.

⚠ WARNING Failure to properly complete each inspection when required may cause death, serious injury or substantial machine damage.

- ☑ Immediately tag and remove from service a damaged or malfunctioning machine.
- ☑ Repair any machine damage or malfunction before operating machine.
- ☑ Keep records on all inspections for three years.
- ☑ Unless otherwise specified, perform each procedure with the machine in the following configuration:
 - Machine parked on a flat level surface
 - Boom in the stowed position
 - Key switch in the OFF position with the key removed
 - Wheels chocked

About This Section

This section contains detailed procedures for each scheduled maintenance inspection.

Each procedure includes a description, safety warnings and step-by-step instructions.

Symbols Legend



Safety alert symbol—used to alert personnel to potential personal injury hazards. Obey all safety messages that follow this symbol to avoid possible injury or death.



⚠ DANGER Red—used to indicate the presence of an imminently hazardous situation which, if not avoided, will result in death or serious injury.



⚠ WARNING Orange—used to indicate the presence of a potentially hazardous situation which, if not avoided, could result in death or serious injury.



⚠ CAUTION Yellow with safety alert symbol—used to indicate the presence of a potentially hazardous situation which, if not avoided, may cause minor or moderate injury.



CAUTION Yellow without safety alert symbol—used to indicate the presence of a potentially hazardous situation which, if not avoided, may result in property damage.



NOTICE Indicates special operation or maintenance information.

- ⦿ Indicates that a specific result is expected after performing a series of steps.

Table A Procedures

A-1

Inspect the Operator's and Safety Manuals

Maintaining the operator's and safety manuals in good condition is essential to safe machine operation. Manuals are included with each machine and should be stored in the container provided in the platform. An illegible or missing manual will not provide safety and operational information necessary for a safe operating condition.

- 1 Check to be sure the storage container is present and in good condition.
- 2 Check to make sure that the operator's, responsibilities and safety manuals are present and complete in the storage container in the platform.
- 3 Examine the pages of each manual to be sure that they are legible and in good condition.
- 4 Always return the manuals to the storage container after use.

NOTICE Contact your authorized Genie distributor or Genie Industries if replacement manuals are needed.

A-2

Inspect the Decals and Placards

Maintaining all of the safety and instructional decals and placards in good condition is mandatory for safe machine operation. Decals alert operators and personnel to the many possible hazards associated with using this machine. They also provide users with operation and maintenance information. An illegible decal will fail to alert personnel of a procedure or hazard and could result in unsafe operating conditions.

- 1 Refer to the *Decals* section in the *Genie Z-20/8N & Genie Z-20/8 & Genie Z-25/8 Operator's Manual* and use the decal list and illustrations to determine that all decals and placards are in place.
- 2 Inspect all decals for legibility and damage. Replace any damaged or illegible decal immediately.

NOTICE Contact your authorized Genie distributor or Genie Industries if replacement decals are needed.

TABLE A PROCEDURES

A-3 Inspect for Damage and Loose or Missing Parts

Daily machine condition inspections are essential to safe machine operation and good machine performance. Failure to locate and repair damage, and discover loose or missing parts may result in an unsafe operating condition.

- 1 Inspect the entire machine for damage and improperly installed or missing parts including:
 - Electrical components, wiring and electrical cables
 - Hydraulic power units, hoses, fittings, cylinders and manifolds
 - Drive motors
 - Boom components and wear pads
 - Dents or damage to machine
 - Tires and wheels
 - Limit switch, alarms and horn
 - Beacon and alarms (if equipped)
 - Nuts, bolts and other fasteners
 - Platform entry mid-rail/gate
 - Brake release components
 - Slide-out component tray
 - Battery pack connections

A-4 Check the Hydraulic Oil Level

Maintaining the hydraulic oil at the proper level is essential to machine operation. Improper hydraulic oil levels can damage hydraulic components. Daily checks allow the inspector to identify changes in oil level that might indicate the presence of hydraulic system problems.

Z-25/8 before serial number 212
Z-20/8 before serial number 122
Z-20/8N before serial number 896:

- 1 Be sure that the boom is in the stowed position.
 - 2 Pull the hydraulic component tray out and visually inspect the oil level in the tank.
- ⊙ Result: The hydraulic oil level should be within 2 inches (5 cm) of the FULL mark on the tank.

Z-25/8 after serial number 211
Z-20/8 after serial number 121
Z-20/8N after serial number 895:

- 1 Raise the boom approximately 1 foot (30 mm).
- 2 Remove the mounting fasteners to the hydraulic access panel located under the boom linkage at the center of the chassis. Remove the panel.

TABLE A PROCEDURES

- 3 Lower the boom to the stowed position.
- 4 Remove the hydraulic oil filler cap/dipstick, located on top of the hydraulic tank.
- 5 Fill the hydraulic tank to the FULL line on the oil filler cap/dipstick. Do not overfill tank.

Hydraulic Oil Specifications - All Models

Hydraulic oil type	Dexron equivalent
Hydraulic tank capacity	8 gallons 30.3 liters
Hydraulic system (including tank)	10 gallons 37.9 liters

A-5 Check for Hydraulic Leaks

Detecting hydraulic fluid leaks is essential to operational safety and good machine performance. Undiscovered leaks can develop into hazardous situations, impair machine functions and damage machine components.

- 1 Inspect for hydraulic oil puddles, dripping or residue on or around the following areas:
 - Hydraulic tank—filter, fittings, hoses and chassis surface
 - Hydraulic power units, fittings, hoses, and chassis surface
 - All hydraulic cylinders
 - All hydraulic manifolds
 - Boom linkage
 - The underside of the drive chassis
 - Ground area under the machine

TABLE A PROCEDURES

A-6 Test the Platform and Ground Controls

Testing the machine functions and the Emergency Stop buttons for malfunctions is essential for safe machine operation. An unsafe working condition exists if any function fails to operate properly or either Emergency Stop button fails to stop all the machine functions. Each function should operate smoothly and be free of hesitation, jerking and unusual noise.

- 1 Turn the key switch to ground control and pull out the Emergency Stop button to the ON position.
- 2 Do not hold the function enable switch to either side. Attempt to activate each boom and platform function toggle switch.
 - ⦿ Result: No boom functions should operate.
- 3 Hold the function enable switch to either side and activate each boom and platform function toggle switch.
 - ⦿ Result: All boom and platform functions should operate through a full cycle. The descent alarm (if equipped) should sound while boom is lowering.
- 4 Turn the key switch to platform control and pull out the Emergency Stop button to the ON position at both the ground and the platform controls.
- 5 Move the lift/drive select switch (if equipped) to the lift position.
- 6 Press down the foot switch.
- 7 Activate each machine function toggle switch.
 - ⦿ Result: All boom/platform functions should operate through a full cycle.
- 8 Move the lift/drive select switch (if equipped) to the drive position.
- 9 Press down the footswitch.
- 10 Activate each drive and steer function.
 - ⦿ Result: All drive and steer functions should operate.
- 11 Push in the Emergency Stop button to the OFF position.
 - ⦿ Result: No function should operate, the machine should stop.

NOTICE

As a safety feature, selecting and operating the ground controls will override the platform controls, including the platform Emergency Stop button.

TABLE A PROCEDURES

A-7 Test the Auxiliary Power Operation

Detection of auxiliary power system malfunctions is essential for safe machine operation. An unsafe working condition exists if the auxiliary powered functions do not operate in the event of a main power loss. Auxiliary power is designed for short term emergency use only. Excessive use will result in battery drain and component damage.

- 1 Turn the key switch to ground control and pull out the Emergency Stop button to the ON position.
- 2 Lift the red auxiliary power switch cover.
- 3 Simultaneously hold the auxiliary power toggle switch ON while activating each boom function through a partial cycle.

NOTICE To conserve battery power, test each function through a partial cycle.

- ⦿ Result: Each function should operate smoothly.
- 4 Turn the key switch to platform control.
 - 5 At the platform controls, pull out the Emergency Stop button to the ON position, then press down the foot switch.
 - 6 Lift the red auxiliary power switch cover.
 - 7 Simultaneously hold the auxiliary power switch ON while activating each function control handle and toggle switch through a partial cycle.
- ⦿ Result: Each function should operate smoothly.

NOTICE Drive and steer functions will operate with auxiliary power.

A-8 Test the Tilt Sensor

The tilt sensor sounds an alarm in the platform when the incline of the drive chassis exceeds the rating on the serial plate.

NOTICE Select a level test area. The tilt alarm should not be sounding prior to test.

- 1 Turn the key switch to ground control and pull out the Emergency Stop button to the ON position at both the ground and the platform controls.
- 2 Lower the platform to the stowed position.
- 3 Locate the tilt sensor on the chassis under the boom.
- 4 Press down one side of the tilt sensor and place the tilt sensor test tool under one of the posts.
- ⦿ Result: The alarm, located in the platform, should sound after 1.5 seconds.
- 5 Raise the boom approximately 5 feet (1.5 m).

TABLE A PROCEDURES

- 6 Test all ground and platform control functions.
 - ⦿ Result: No drive functions should operate. The boom up function should not operate. The jib boom function should not operate. The jib rotate function should not operate. Activating the down function should cause the hydraulic pump to run.
- 7 Remove the tilt sensor test tool.

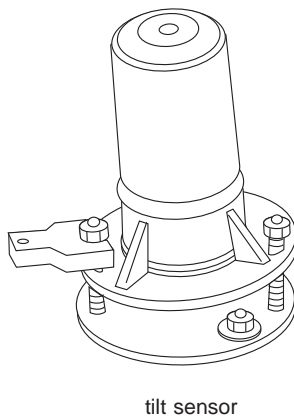

A-9 Test the Drive Speed Limit Switch

Detecting drive speed limit switch malfunctions is essential to safe machine operation. The drive speed limit switch is used to restrict drive speed when the boom is raised. An improperly functioning drive speed limit switch will allow the boom to raise and/or drive into an unsafe position.

Z-25/8 before serial number 233
Z-20/8 before serial number 125
Z-20/8N before serial number 1073:

- 1 Locate the drive speed limit switch through the access hole located below the boom rest.

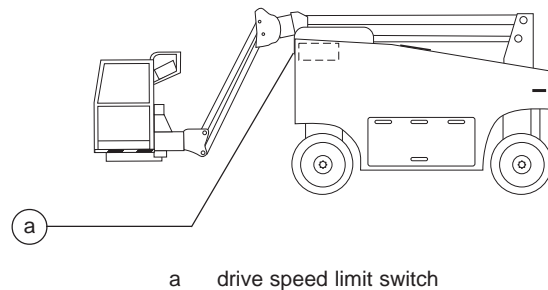

- 2 With the boom in the stowed position, visually inspect the boom limit switch for the following:
 - Broken or missing roller arm
 - Missing fasteners
 - Loose wiring

TABLE A PROCEDURES

- 3 Manually activate the drive speed limit switch.
- ⊙ Result: The drive speed limit switch roller arm should move freely and spring return to center. A distinct click should be felt and heard.
- 4 Turn the key switch to platform control and pull out the Emergency Stop button to the ON position at both ground and platform controls.
- 5 Press down the foot switch.
- 6 Move the lift/drive select switch (if equipped) to the drive position.
- 7 Slowly move the drive control handle off center.
- ⊙ Result: The machine should move at normal drive speeds.
- 8 Raise the boom approximately 12 to 14 inches (30 to 36 cm).
- 9 Slowly move the drive control handle off center.
- ⊙ Result: The machine should move at a reduced drive speed.

Raised Drive speed (maximum)

Boom raised	40 ft/40 sec	12.2 m/40 sec
-------------	--------------	---------------

Z-25/8 after serial number 232
Z-20/8 after serial number 124
Z-20/8N after serial number 1072:

- 1 Fully raise the boom and turn the machine off.
- 2 Locate the drive speed limit switch inside of the boom storage area.

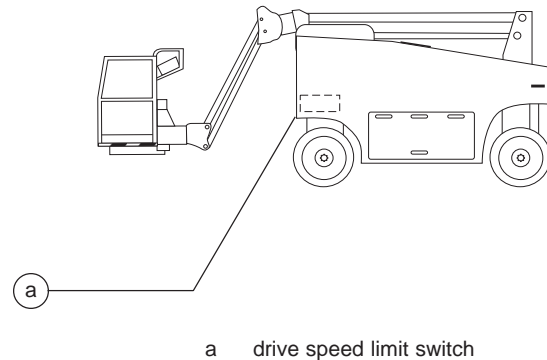

- 3 With the boom in the raised position, visually inspect the boom limit switch for the following:
 - Broken or missing arm
 - Missing fasteners
 - Loose wiring
- 4 Manually activate the drive speed limit switch.
- ⊙ Result: The drive speed limit switch arm should move freely and spring return to center. A distinct click should be felt and heard.

TABLE A PROCEDURES

- 5 Turn the key switch to ground control and pull out the Emergency Stop button to the ON position.
- 6 Lower the boom to the stowed position.
- 7 Turn the key switch to platform control and pull out the Emergency Stop button to the ON position at both ground and platform controls.
- 8 Press down the foot switch.
- 9 Move the lift/drive select switch (if equipped) to the drive position.
- 10 Slowly move the drive control handle off center.
- ⊙ Result: The machine should move at normal drive speeds.
- 11 Raise the boom approximately 12 to 14 inches (30.5 to 35.6 cm).
- 12 Slowly move the drive control handle off center.
- ⊙ Result: The machine should move at a reduced drive speed.

Raised Drive speed (maximum)

Boom raised	40 ft/40 sec	12.2 m/40 sec
-------------	--------------	---------------

A-10 Perform 30 Day Service

The 30 day maintenance procedure is a one time sequence of procedures to be performed after the first 30 days or 50 hours of usage. After this interval, refer to the maintenance tables for continued scheduled maintenance.

- 1 Perform the following maintenance procedures:
 - B-3 Inspect the Tires and Wheels
 - B-15 Replace the Hydraulic Tank Return Filter

Table B Procedures

B-1

Check the Batteries

Proper battery condition is essential to good machine performance and operational safety. Improper fluid levels or damaged cables and connections can result in engine component damage and hazardous conditions.

⚠ WARNING Bodily injury hazard. Batteries contain acid. Avoid spilling or contacting battery acid. Neutralize battery acid spills with baking soda and water.

⚠ WARNING Electrocutation hazard. Contact with hot or live circuits could result in death or serious injury. Remove all rings, watches and other jewelry.

NOTICE Perform this procedure with the batteries fully charged.

- 1 Put on protective clothing and eye wear.
- 2 Disconnect the battery packs from the machine.
- 3 Be sure that the battery cable connections are free of corrosion.

- 4 Be sure that the battery hold downs and cable connections are tight.
- 5 Remove the battery vent caps and check the specific gravity of each battery cell with a hydrometer.
 - ⦿ Result: If any battery cell displays a specific gravity of less than 1.026, the battery must be replaced.
- 6 Check the battery acid level of each battery. If needed, replenish with distilled water to the bottom of the battery fill tube. Do not overfill.
- 7 Install the battery vent caps.
- 8 Check each battery pack and verify that the batteries are wired correctly.
- 9 Connect the battery packs to the machine.

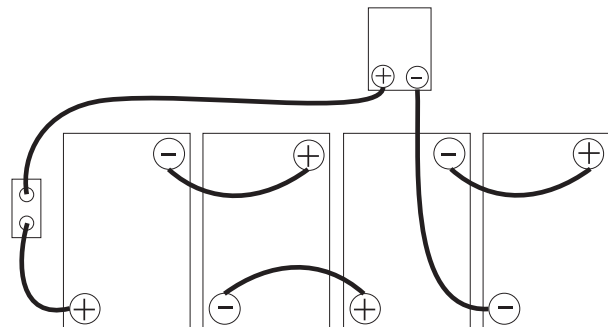

TABLE B PROCEDURES

B-2 Inspect the Electrical Wiring

Maintaining electrical wiring in good condition is essential to safe operation and good machine performance. Failure to find and replace burnt, chafed, corroded or pinched wires could result in unsafe operating conditions and may cause component damage.

⚠WARNING Electrocutation hazard. Contact with hot or live circuits could result in death or serious injury. Remove all rings, watches and other jewelry.

- 1 Inspect the following areas for burnt, chafed, corroded and loose wires:
 - Electronic control module panel
 - Hydraulic component tray
 - Ground control panel
 - Function manifold wiring
- 2 Turn the key switch to ground control and pull out the Emergency Stop button to the ON position.
- 3 Raise the boom until the platform is 10 feet (3 m) off the ground.
- 4 Inspect the boom storage area for burnt, chafed and pinched cables.
- 5 Lower the boom to the stowed position and turn the machine off.
- 6 Inspect the following areas for burnt, chafed, corroded, pinched and loose wires:
 - Boom to platform cable harness
 - Inside of the platform control box
 - Jib boom rotate manifold wiring

TABLE B PROCEDURES

B-3 Inspect the Tires and Wheels (including castle nut torque)

Maintaining the tires and wheels in good condition is essential to safe operation and good performance. Tire and/or wheel failure could result in a machine tip-over. Component damage may also result if problems are not discovered and repaired in a timely fashion.

- 1 Check the tire surface and sidewalls for cuts, cracks, punctures and unusual wear.
- 2 Check each wheel for damage, bends and cracks.
- 3 Remove the cotter pin and check each castle nut for proper torque.
- 4 Install a new cotter pin.

NOTICE Always replace the cotter pin with a new one when removing the castle nut or when checking the torque of the castle nut.

Tires and wheels

Castle nut torque, dry	300 ft-lbs	406.7 Nm
Castle nut torque, lubricated	225 ft-lbs	305 Nm

B-4 Test the Key Switch

Proper key switch action and response is essential to safe machine operation. The machine can be operated from the ground or platform controls and the activation of one or the other is accomplished with the key switch. Failure of the key switch to activate the appropriate control panel could cause a hazardous operating situation.

- 1 Pull out the Emergency Stop button to the ON position at both the ground and platform controls.
- 2 Turn the key switch to **platform control**.
- 3 Check the machine functions from the **ground controls**.
 - ⊙ Result: The machine functions should **not** operate.
- 4 Turn the key switch to **ground control**.
- 5 Check the machine functions from the **platform controls**.
 - ⊙ Result: The machine functions should **not** operate.
- 6 Turn the key switch to the OFF position.
 - ⊙ Result: No function should operate, the machine should stop.

TABLE B PROCEDURES

B-5 Test the Emergency Stop Buttons

Properly functioning Emergency Stop buttons are essential for safe machine operation. An improperly operating Emergency Stop button will fail to shut off power and stop all machine functions resulting in a hazardous situation.

NOTICE As a safety feature, selecting and operating the ground controls will override the platform controls, including the Emergency Stop button.

- 1 Turn the key switch to ground control and pull out the Emergency Stop button to the ON position.
 - 2 Push down the ground controls Emergency Stop button to the OFF position.
- ⦿ Result: No functions should operate.
- 3 Turn the key switch to platform control and pull out the Emergency Stop button to the ON position at both the ground and platform controls.
 - 4 Push down the platform controls Emergency Stop button to the OFF position.
- ⦿ Result: No machine functions should operate.

NOTICE The ground Emergency Stop button will stop all machine operation, even if the key switch is switched to platform control.

B-6 Test the Ground Control Override

A properly functioning ground control override is essential to safe machine operation. The ground control override function is intended to allow ground personnel to operate the machine from the ground controls whether or not the Emergency Stop button at the platform controls is in the ON or OFF position. This function is particularly useful if the operator at the platform controls cannot return the boom to the stowed position.

- 1 Press in the platform Emergency Stop button to the OFF position.
 - 2 Turn the key switch to ground control and pull out the Emergency Stop button to the ON position.
 - 3 Operate each boom function through a partial cycle at the ground controls.
- ⦿ Result: All boom functions should operate.

TABLE B PROCEDURES

B-7 Test the Horn

A functioning horn is essential to safe machine operation. The horn is activated at the platform controls and sounds at the ground as a warning to ground personnel. An improperly functioning horn will prevent the operator from alerting ground personnel of hazards or unsafe conditions.

- 1 Turn the key switch to platform control and pull out the Emergency Stop button to the ON position at both the ground and platform controls.
- 2 Press down the horn button at the platform controls.

⦿ Result: The horn should sound.

NOTICE If necessary, the horn can be adjusted to obtain the loudest volume by turning the adjustment screw near the wire terminals on the horn.

B-8 Test the Foot Switch

A properly functioning foot switch is essential to safe machine operation. Machine functions should activate and operate smoothly as long as the foot switch is pressed down, and promptly stop when the foot switch is released. An improperly functioning foot switch can cause an unsafe working condition.

- 1 Turn the key switch to platform control and pull out the Emergency Stop button to the ON position at both the ground and platform controls.
- 2 Move the lift/drive select switch (if equipped) to the lift or drive position.
- 3 Without pressing down the foot switch, check the machine lift/drive functions.

⦿ Result: The machine lift/drive functions should **not** operate.

- 4 Press down the foot switch.
- 5 Move the lift/drive select switch (if equipped) to the lift or drive position.

⦿ Result: The machine lift or drive functions should operate.

TABLE B PROCEDURES

B-9 Test the Drive Brakes

Proper brake action is essential to safe machine operation. The drive brake function should operate smoothly, free of hesitation, jerking and unusual noise. Hydraulically-released individual wheel brakes can appear to operate normally when not fully operational.

NOTICE Select a test area that is firm, level and free of obstructions.

- 1 Mark a test line on the ground for reference.
- 2 Turn the key switch to platform control and pull out the Emergency Stop button to the ON position at both the ground and platform controls.
- 3 Press down the foot switch.
- 4 Move the lift/drive select switch (if equipped) to the lift position.
- 5 Lower the boom into the stowed position.

- 6 Move the lift/drive select switch (if equipped) to the drive position.
- 7 Choose a point on the machine; i.e., contact patch of a tire, as a visual reference for use when crossing the test line.
- 8 Bring the machine to top drive speed before reaching the test line. Release the drive joystick when your reference point on the machine crosses the test line.
- 9 Measure the distance between the test line and your machine reference point.

Braking: paved surface

Stopping distance	3 to 4 ft	0.9 to 1.2 m
--------------------------	-----------	--------------

NOTICE The brakes must be able to hold the machine on any slope it is able to climb.

TABLE B PROCEDURES

B-10**Test the Drive Speed -
Stowed Position**

Proper drive function movement is essential to safe machine operation. The drive function should respond quickly and smoothly to operator control. Drive performance should also be free of hesitation, jerking and unusual noise over the entire proportionally controlled speed range.

NOTICE Select a test area that is firm, level and free of obstructions.

- 1 Create start and finish lines by marking two lines on the ground 40 feet (12.2 m) apart.
- 2 Turn the key switch to platform control and pull out the Emergency Stop button to the ON position at both the ground and platform controls.
- 3 Press down the foot switch.
- 4 Move the lift/drive select switch (if equipped) to the lift position.
- 5 Lower the boom into the stowed position.
- 6 Move the lift/drive select switch (if equipped) to the drive position.

NOTICE Be sure the drive speed select switch is set to the HIGH position.

- 7 Choose a point on the machine; i.e., contact patch of a tire, as a visual reference for use when crossing the start and finish lines.
- 8 Bring the machine to maximum drive speed before reaching the start line. Begin timing when your reference point on the machine crosses the start line.
- 9 Continue at full speed and note the time when the machine reference point passes over the finish line.

Drive speed:	2.7 mph	4 km/h
stowed position	40 ft/10.5 sec	12.2 m/10.5 sec

TABLE B PROCEDURES

B-11 Test the Drive Speed - Raised Position

Proper drive function movement is essential to safe machine operation. The drive function should respond quickly and smoothly to operator control. Drive performance should also be free of hesitation, jerking and unusual noise over the entire proportionally controlled speed range.

NOTICE Select a test area that is firm, level and free of obstructions.

- 1 Create start and finish lines by marking two lines on the ground 40 feet (12.2 m) apart.
- 2 Turn the key switch to platform control and pull out the Emergency Stop button to the ON position at both the ground and platform controls.
- 3 Press down the foot switch.
- 4 Move the lift/drive select switch (if equipped) to the lift position.

- 5 Raise the boom more than 5 feet (1.5 m).
- 6 Move the lift/drive select switch (if equipped) to the drive position.

NOTICE Be sure the drive speed select switch is set to the HIGH position.

- 7 Choose a point on the machine; i.e., contact patch of a tire, as a visual reference for use when crossing the start and finish lines.
- 8 Bring the machine to maximum drive speed before reaching the start line. Begin timing when your reference point on the machine crosses the start line.
- 9 Continue at full speed and note the time when the machine reference point passes over the finish line.

Drive speed:	0.6 mph	0.8 km/h
raised position	40 ft/40 sec	12.2 m/10.5 sec

TABLE B PROCEDURE

B-12 Test the Alarm Package (If Equipped)

The alarm package includes:

- Travel alarm
- Descent alarm
- Flashing beacon

Alarms and a beacon are installed to alert operators and ground personnel of machine proximity and motion. The flashing beacon is installed on the lower leveling arm and the descent and travel alarms are installed on the rear of the machine above the hydraulic component tray.

- 1 Turn the key switch to ground control and pull out the Emergency Stop button to the ON position at both the ground and platform controls.
 - ⊙ Result: The flashing beacon should be on and flashing.
- 2 Move the boom toggle switch to the DOWN position, hold for a moment and then release it.
 - ⊙ Result: The descent alarm should sound when the switch is held down.
- 3 Turn the key switch to platform control.
- 4 Move the lift/drive select switch (if equipped) to the lift position.
 - ⊙ Result: The flashing beacon should be on and flashing.
- 5 Press down the foot switch.
 - ⊙ Result: The flashing beacon should be on and flashing.
- 6 Press down the foot switch. Move the boom toggle switch to the DOWN position, hold for a moment and then release it.
 - ⊙ Result: The descent alarm should sound when the switch is held down.
- 7 Move the lift/drive select switch (if equipped) to the drive position.
- 8 Press down the foot switch.
- 9 Move the drive control handle off center, hold for a moment and then release it. Move the drive control handle off center in the opposite direction, hold for a moment and then release it.
 - ⊙ Result: The travel alarm should sound when the drive control handle is moved off center in either direction.

TABLE B PROCEDURE

B-13 Perform Hydraulic Oil Analysis

See D-1, *Test or Replace the Hydraulic Oil*.

B-14 Check the Electrical Contactors

Maintaining the electrical contactors in good condition is essential to safe machine operation. Failure to locate a worn or damaged contactor could result in an unsafe working condition and component damage.

- 1 Remove the access cover from the right side counterweight and locate the electrical contactors mounted on the component mounting panel.
- 2 Visually inspect the contact points of each contactor for the following items:
 - Excessive burns
 - Excessive arcs
 - Excessive pitting

▲WARNING Electrocutation hazard. Contact with hot or live circuits could result in death or serious injury. Remove all rings, watches and other jewelry.

NOTICE Replace the contactors if any damage is found.

B-15 Replace the Hydraulic Tank Return Filter

NOTICE Genie requires that this procedure be performed quarterly or every 250 hours, whichever comes first. Perform this procedure more often if dusty conditions exist.

Replacement of the hydraulic return filter is essential for good machine performance and service life. A dirty or clogged filter may cause the machine to perform poorly and continued use may cause component damage. Extremely dirty conditions may require that the filter be replaced more often.

▲CAUTION Bodily injury hazard. Beware of hot oil. Contact with hot oil may cause severe burns.

Z-25/8 before serial number 212
Z-20/8 before serial number 122
Z-20/8N before serial number 896:

NOTICE The hydraulic return filter is located inside of the hydraulic component tray.

- 1 Clean the area around the oil filter housing, then remove the filter with an oil filter wrench.
- 2 Apply a thin layer of fresh oil to the gasket on the new oil filter.
- 3 Install the new filter (Genie part number 44788) and tighten it securely by hand.

TABLE B PROCEDURES

- 4 Turn the key switch to ground controls and pull out the Emergency Stop button to the ON position.
 - 5 Hold the function enable toggle switch to either side and move the boom up toggle switch in the UP direction.
 - 6 Inspect the filter and related components to be sure that there are no leaks.
 - 7 Clean up any oil that may have spilled during the replacement procedure. Properly discard the oil.
- Z-25/8 after serial number 211**
Z-20/8 after serial number 121
Z-20/8N after serial number 895:
- 1 Raise the boom approximately 1 foot (0.3 m).
 - 2 Remove the retaining fasteners from the access panel located underneath the boom linkage. Remove the access panel.
 - 3 Clean the area around the oil filter housing located on top of the tank.
 - 4 Remove the oil filter housing cover fasteners, then remove the cover.
 - 5 Remove the oil filter element from the housing.
 - 6 Clean the oil filter housing with a mild solvent.
 - 7 Install the new oil filter element (Genie part number 58995).
 - 8 Install the oil filter housing cover and tighten the fasteners.
 - 9 Turn the key switch to ground controls and pull out the Emergency Stop button to the ON position.
 - 10 Hold the function enable toggle switch to either side and move the boom up toggle switch in the UP direction.
 - 11 Inspect the filter and related components to be sure that there are no leaks.
 - 12 Clean up any oil that may have spilled during the replacement procedure. Properly discard the oil.
 - 13 Lower the boom to the stowed position.
-
- Oil filters - Genie part numbers**
-
- | | |
|-----------------------------------|-------|
| Z-25/8 before serial number 212 | |
| Z-20/8 before serial number 122 | |
| Z-20/8N before serial number 896: | 44788 |
-
- | | |
|----------------------------------|-------|
| Z-25/8 after serial number 211 | |
| Z-20/8 after serial number 121 | |
| Z-20/8N after serial number 895: | 58995 |
-

Table C Procedure

C-1

Bleed the Jib Boom Rotator

The jib boom rotator is a hydraulically-activated, helical gear assembly used to rotate the jib boom assembly 160 degrees.

- 1 Connect a clear hose to the top bleed valve. Place the other end of the hose in a container to collect any discharge.

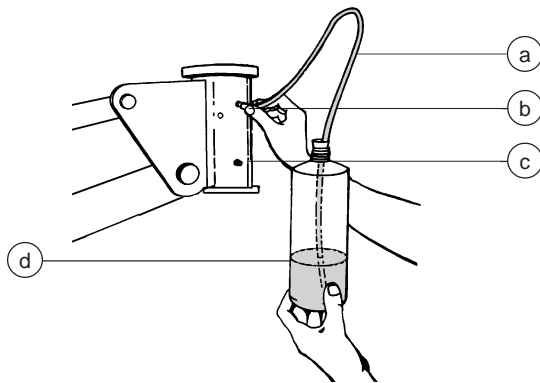

- a clear hose
- b top bleed valve
- c bottom bleed valve
- d container

- 2 Open the top bleed valve, but do not remove it.
- 3 Turn the key switch to ground control and pull out the Emergency Stop button to the ON position.
- 4 Hold the function enable switch to either side and move the jib boom rotate toggle switch in the RIGHT direction for approximately 5 seconds, then release it. Repeat three times.

CAUTION Crushing hazard. Keep hands clear of the jib boom pivot weldment during rotation.

- 5 Hold the function enable switch to either side and move the jib boom rotate toggle switch in the LEFT direction for approximately 5 seconds, then release it. Repeat three times.
- 6 Fully rotate the jib boom in the LEFT direction and continue holding the jib boom rotate toggle switch until air stops coming out of the bleed valve. Immediately release the jib boom rotate switch and close the bleed valve.
- 7 Rotate the jib boom to the right until it is centered.
- 8 Connect the clear hose to the bottom bleed valve and open the valve.
- 9 Rotate the jib boom in the RIGHT direction and continue holding the jib boom rotate toggle switch until air stops coming out of the bleed valve.

CAUTION Crushing hazard. Keep hands clear of the jib boom pivot weldment during rotation.

- 10 Close the bleed valve and remove the hose.
- 11 Turn the key switch to the OFF position and clean up any hydraulic oil that may have spilled.
- 12 Turn the key switch to ground control and pull out the Emergency Stop button to the ON position.
- 13 Hold the function enable switch to either side and move the jib boom rotate toggle switch to the full right and left directions and inspect the bleed valves for leaks.

Table D Procedure

D-1

Test or Replace the Hydraulic Oil

Replacement or testing of the hydraulic oil is essential for good machine performance and service life. Dirty oil and suction strainers may cause the machine to perform poorly and continued use may cause component damage. Extremely dirty conditions may require oil changes to be performed more often.

NOTICE The machine uses Dexron equivalent hydraulic oil. Before replacing the hydraulic oil, the oil may be tested by an oil distributor for specific levels of contamination to verify that changing the oil is necessary. **If the hydraulic oil is not replaced at the two year inspection, test the oil quarterly. Replace the oil when it fails the test.**

NOTICE When removing a hose assembly or fitting, the O-ring on the fitting and/or hose end must be replaced and then torqued to specification during installation. Refer to Section Two, *Hydraulic Hose and Fitting Torque Specifications*.

NOTICE Perform this procedure with the boom in the stowed position and the jib boom rotated to one side.

- 1 Locate the drain hose underneath the hydraulic tank. Remove the drain plug from the drain hose.
- 2 Completely drain the tank into a suitable container. See capacity specifications.

WARNING Bodily injury hazard. Spraying hydraulic oil can penetrate and burn skin. Loosen hydraulic connections very slowly to allow the oil pressure to dissipate gradually. Do not allow oil to squirt or spray.

- 3 Open the battery trays on each side of the machine.
- 4 Disconnect the battery packs at the quick disconnect plugs.
- 5 Tag and disconnect the battery cables from the auxiliary power unit located at the steer end of the component tray.

WARNING Electrocutation hazard. Contact with electrically charged circuits could result in death or serious injury. Remove all rings, watches and other jewelry.

- 6 Locate the negative battery cable that goes from the auxiliary power unit to the motor controller.

TABLE D PROCEDURE

7 Pull the cable out from under the hydraulic tank. Do not disconnect the cable from the motor controller.

8 Tag and disconnect the battery cables from the hydraulic power unit.

▲WARNING Electrocutation hazard. Contact with electrically charged circuits could result in death or serious injury. Remove all rings, watches and other jewelry.

9 Tag, disconnect and plug all of the hoses on the function manifold. Cap the fittings on the manifold.

▲WARNING Bodily injury hazard. Spraying hydraulic oil can penetrate and burn skin. Loosen hydraulic connections very slowly to allow the oil pressure to dissipate gradually. Do not allow oil to squirt or spray.

10 Secure the hydraulic hoses out of the way of the component tray.

▲CAUTION Component damage hazard. Hoses can be damaged if they are kinked or pinched.

11 Tag and disconnect the wiring from the power to platform plug located on the component tray. Pull the wiring through the squeeze connector and the clamps.

▲WARNING Electrocutation hazard. Contact with electrically charged circuits could result in death or serious injury. Remove all rings, watches and other jewelry.

12 Tag and disconnect all of the wiring from the function manifold.

13 Remove the clamps from the function manifold and secure all wiring out of the way.

▲CAUTION Component damage hazard. Cables and wiring can be damaged if they are kinked or pinched.

14 Support the component tray with a suitable lifting device.

15 Remove the retaining fasteners from the roller wheel stop blocks on the component tray slide tracks. Remove the stop blocks from the machine.

16 Carefully slide the component tray towards the non-steer end of the machine. Remove the component tray from the machine.

▲CAUTION Crushing hazard. The component tray may fall when it is removed from the machine if it is not properly supported by the lifting device.

▲CAUTION Component damage hazard. Be careful not to damage any wiring or hoses while removing the component tray.

17 Disconnect the suction hoses from the suction strainers in the hydraulic tank at both end of the hydraulic tank.

18 Remove the hydraulic tank from the machine.

19 Remove the suction strainers from the hydraulic tank and clean them with a mild solvent.

TABLE D PROCEDURE

- 20 Rinse out the inside of the tank with a mild solvent.
- 21 Apply thread sealant to the threads of the suction strainers and install them into the tank.

Z-25/8 before serial number 212
Z-20/8 before serial number 122
Z-20/8N before serial number 896:

CAUTION Component damage hazard. The hydraulic tank may become damaged if the suction strainers are over tightened.

All models:

- 22 Install the drain plug into the drain hose.
- 23 Install the hydraulic tank into the component tray and connect the suction hoses from the pumps to the hydraulic tank.
- 24 Install the component tray into the chassis and install the roller wheel stop blocks.
- 25 Connect all the hydraulic hoses and wiring.
- 26 **Z-25/8 before serial number 212**
Z-20/8 before serial number 122
Z-20/8N before serial number 896: Fill the tank with hydraulic oil until the fluid reaches the FULL mark on the outside of the tank. Do not overfill.
- Z-25/8 after serial number 211**
Z-20/8 after serial number 121
Z-20/8N after serial number 895: Fill the tank with hydraulic oil until the fluid reaches the FULL mark on the hydraulic oil filler cap/dipstick.

- 27 Clean up any oil that may have spilled. Properly discard of oil.
- 28 Connect the battery packs and operate all machine functions to check for leaks and proper operation.

Hydraulic Oil Specifications

Hydraulic oil type	Dexron equivalent	
Hydraulic tank capacity	8 gallons	30.3 liters
Hydraulic system (including tank)	10 gallons	37.9 liters

Troubleshooting Flow Charts



Observe and Obey:

- ☑ Troubleshooting and repair procedures shall be completed by a person trained and qualified on the repair of this machine.
- ☑ Immediately tag and remove from service a damaged or malfunctioning machine.
- ☑ Repair any machine damage or malfunction before operating the machine.
- ☑ Unless otherwise specified, perform each repair procedure with the machine in the following configuration:
 - Machine parked on a flat level surface
 - Boom in stowed position
 - Key switch in the OFF position with the key removed
 - Wheels chocked

Before Troubleshooting:

- ☑ Read, understand and obey the safety rules and operating instructions printed in the *Genie Z-20/8N, Z-20/8 and Z-25/8 Operator's Manual*.
- ☑ Be sure that all necessary tools and test equipment are available and ready for use.
- ☑ Read each appropriate flow chart thoroughly. Attempting shortcuts may produce hazardous conditions.
- ☑ Be aware of the following hazards and follow generally accepted safe workshop practices.

⚠ DANGER Crushing hazard. When testing or replacing any hydraulic component, always support the structure and secure it from movement.

⚠ WARNING Electrocutation hazard. Contact with electrically charged circuits may result in death or serious injury. Remove all rings, watches and other jewelry.

⚠ WARNING Bodily injury hazard. Spraying hydraulic oil can penetrate and burn skin. Loosen hydraulic connections very slowly to allow the oil pressure to dissipate gradually. Do not allow oil to squirt or spray.

NOTICE Perform all troubleshooting on a firm level surface.

NOTICE Two persons will be required to safely perform some troubleshooting procedures.

TROUBLESHOOTING FLOW CHARTS

About This Section

When a malfunction is discovered, the flow charts in this section will help a service professional pinpoint the cause of the problem. To use this section, basic hand tools and certain pieces of test equipment are required—voltmeter, ohmmeter, pressure gauges.

The location of terminals mentioned in this section can be found on the appropriate electrical or hydraulic schematics provided in Section 6, *Schematics*.

Since various degrees of a particular function loss may occur, selecting the appropriate flow chart may be troublesome. When a function will not operate with the same speed or power as a machine in good working condition, refer to the flow chart which most closely describes the problem.

General Repair Process

Chart 1

All Functions Will Not Operate

Be sure key switch is in the appropriate position.

Be sure both Emergency Stop buttons are pulled out to the ON position.

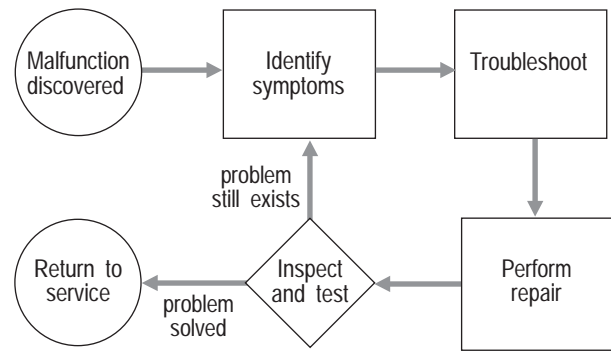
Be sure the circuit breakers and fuses are not tripped or blown.

Be sure the battery packs are properly connected.

Be sure the batteries are fully charged.

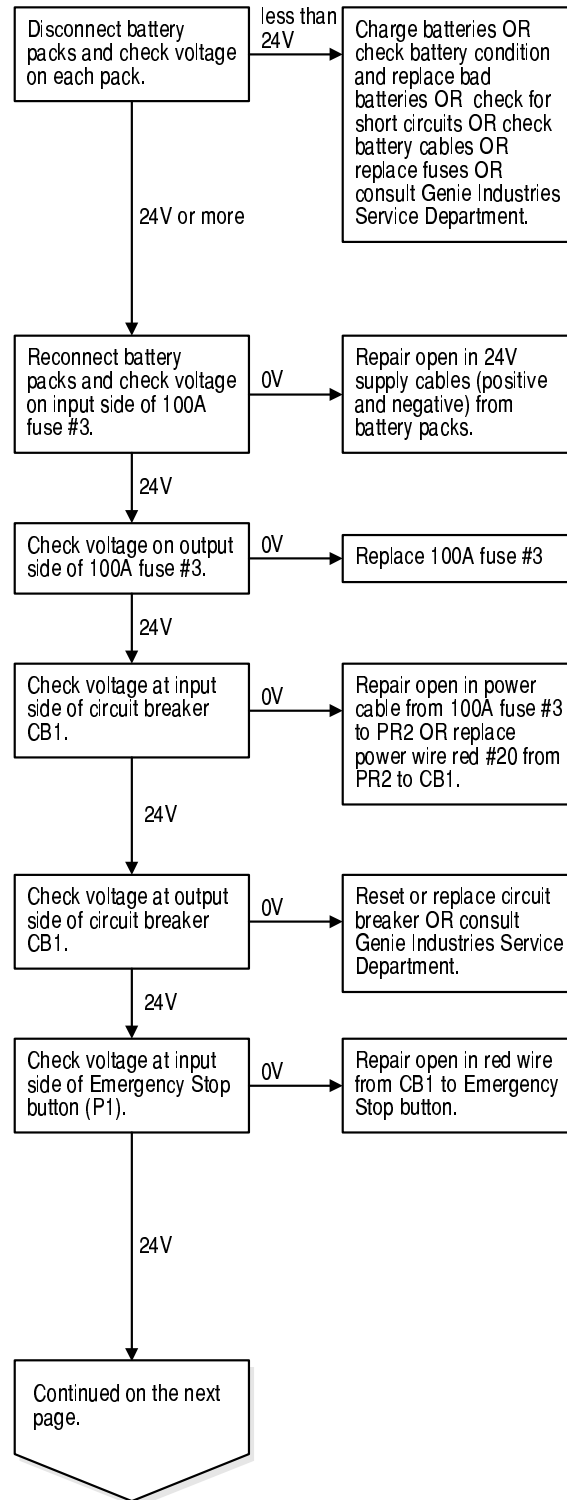

CHART 1

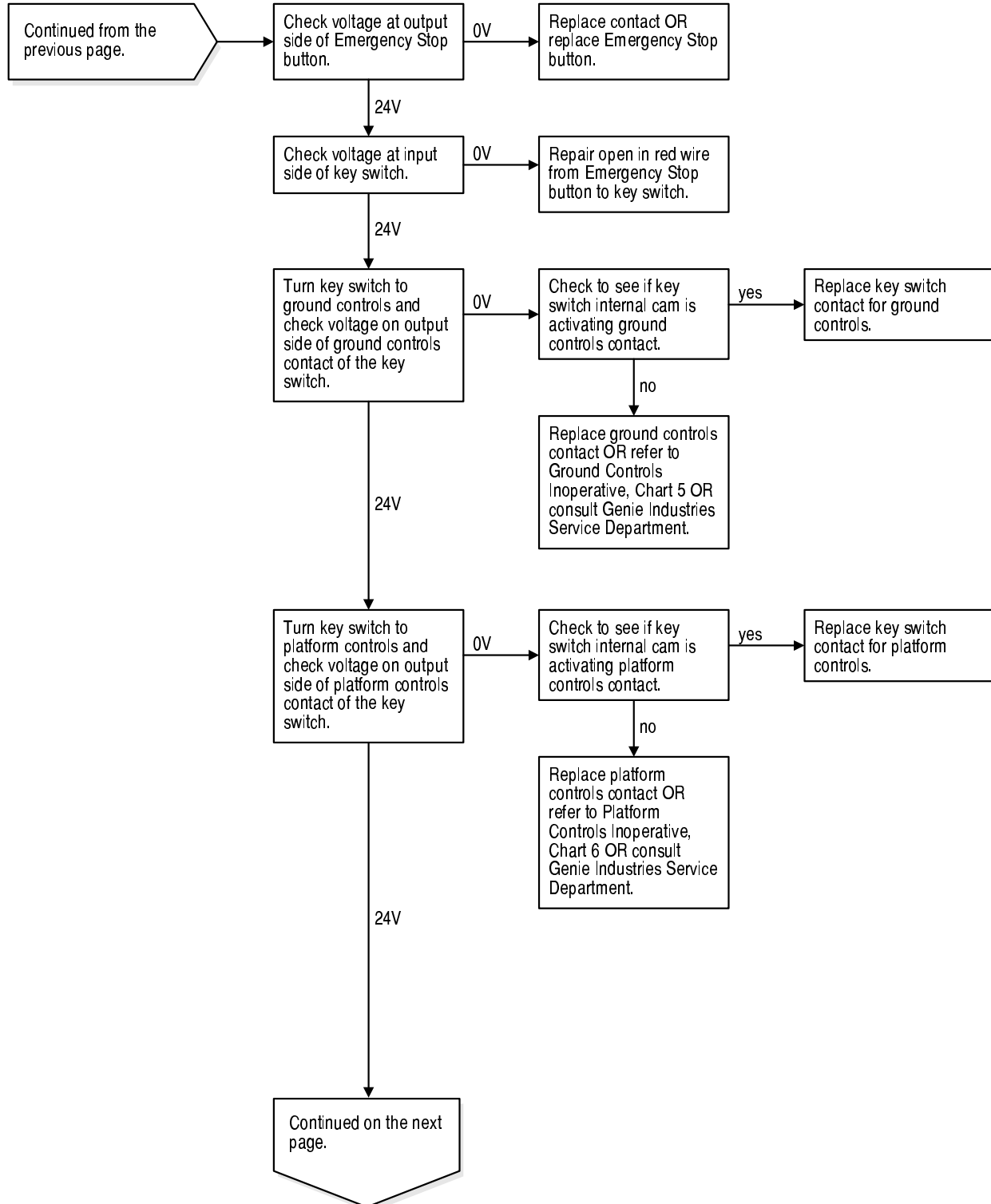

CHART 1

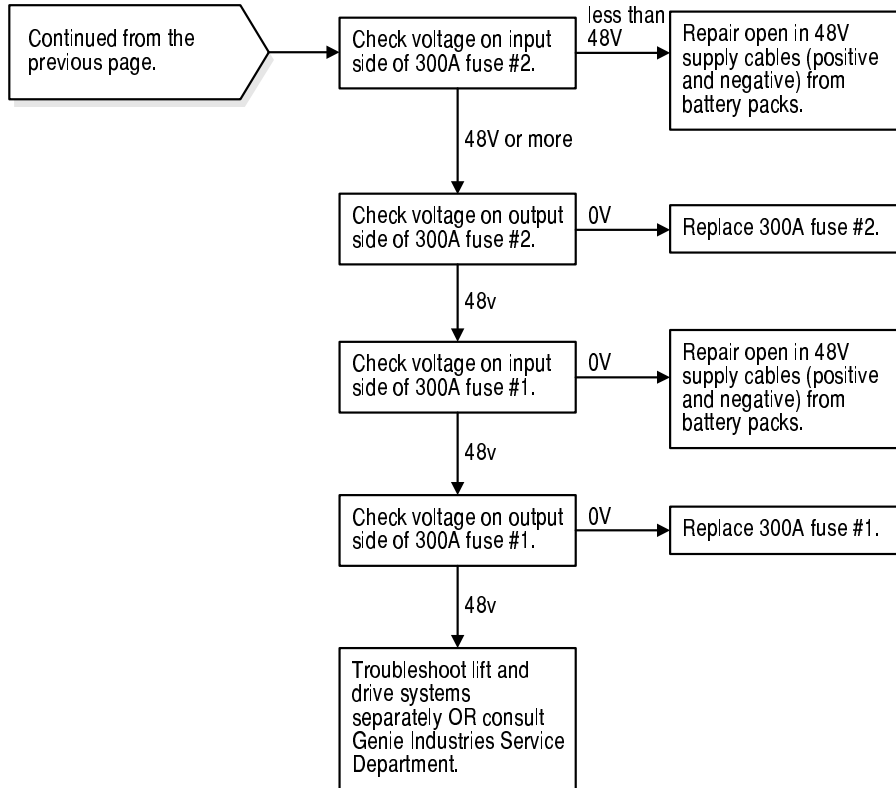

Chart 2

Pump Motor Will Not Operate

Be sure the circuit breakers and fuses are not tripped or blown.

Be sure the batteries are properly connected.

Be sure the batteries are fully charged.

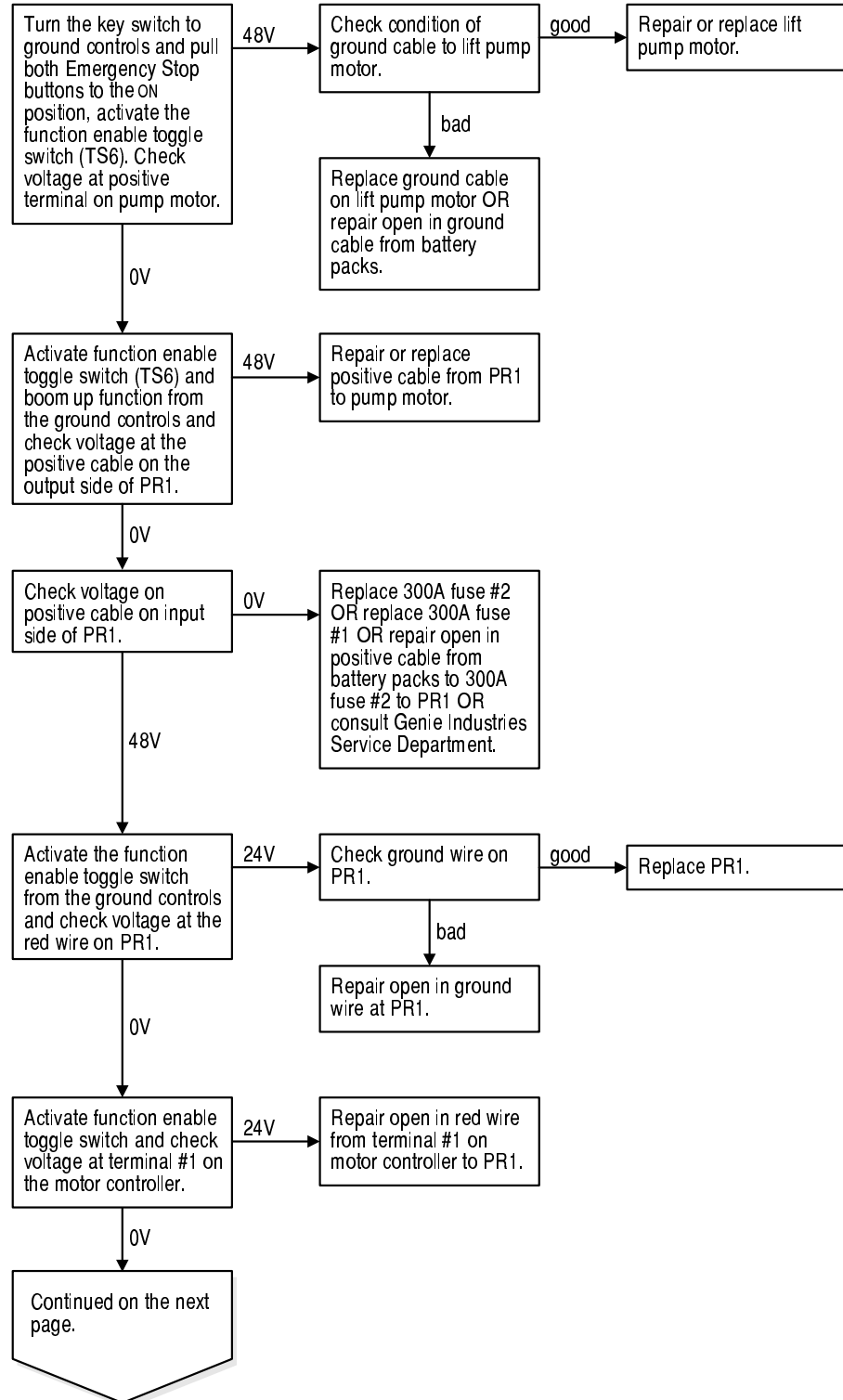

CHART 2

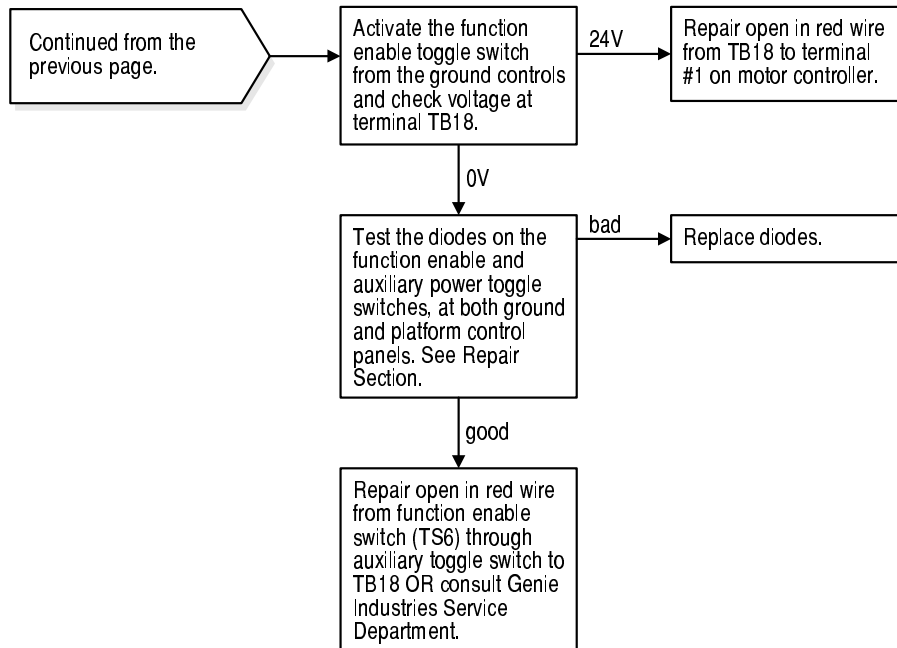

Chart 3

Auxiliary Functions Inoperative

Be sure all other functions operate normally.

Be sure key switch is in the appropriate position.

Be sure the Emergency Stop buttons are pulled out to the ON position.

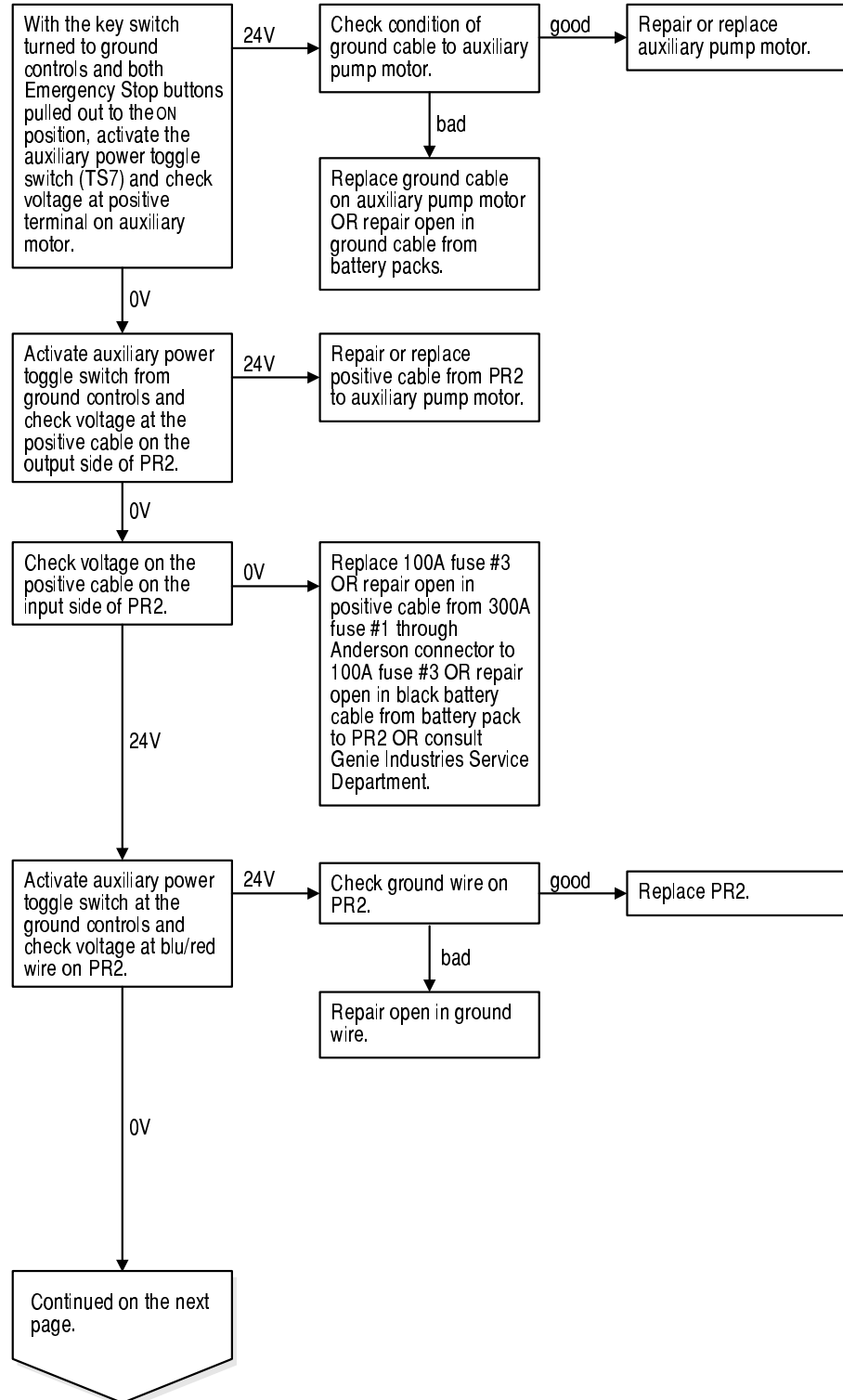

CHART 3

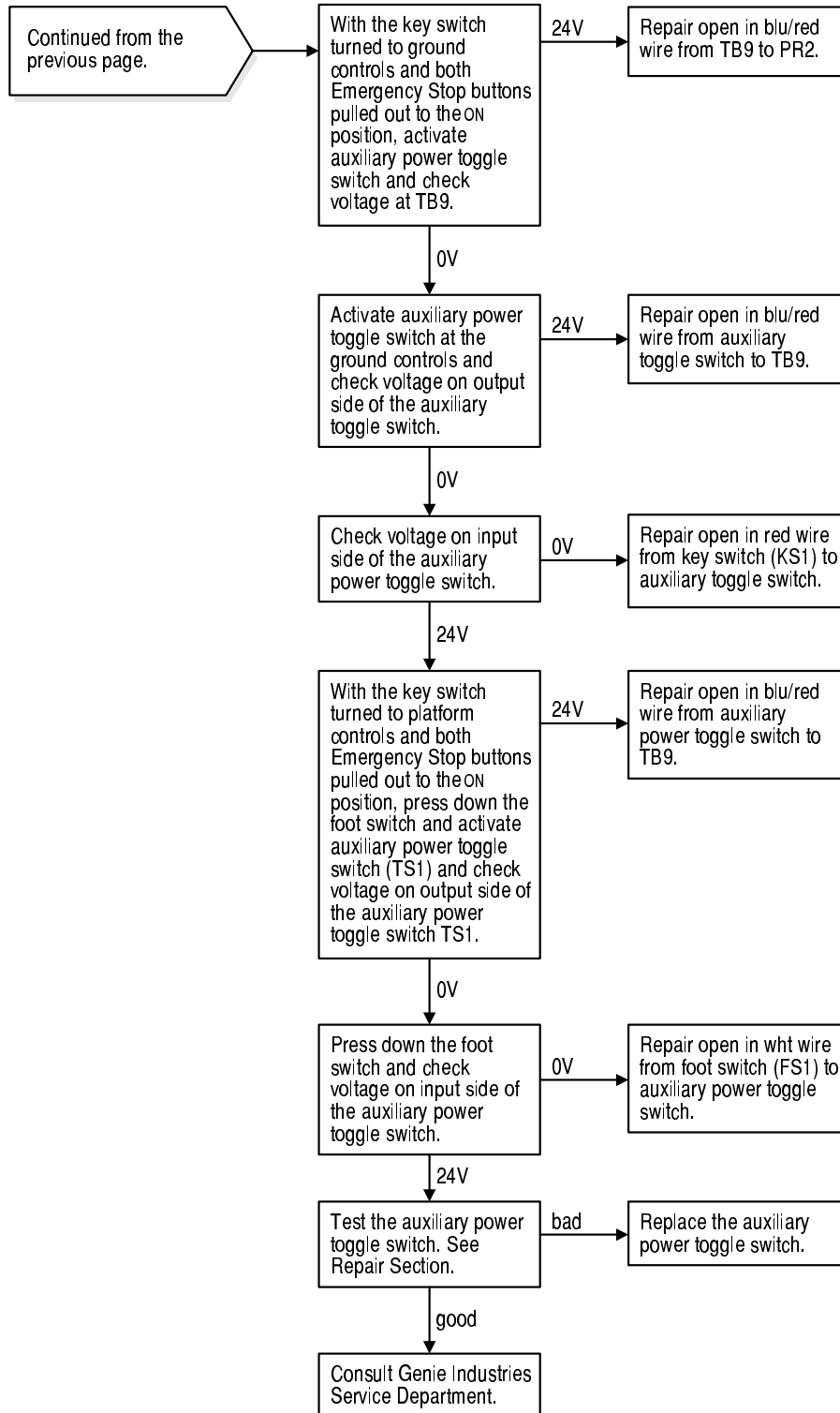

Chart 4

All Functions Inoperative, Power Unit Starts and Runs

Be sure battery packs are properly connected.

Be sure batteries are fully charged.

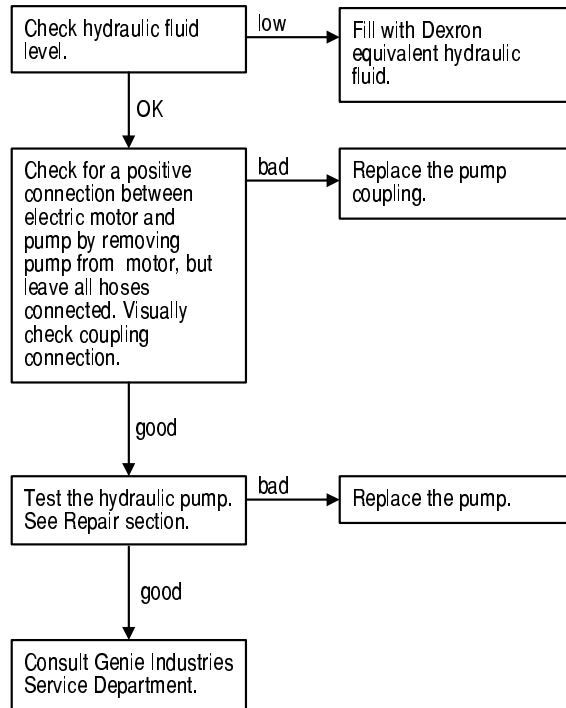

Chart 5

Ground Controls Inoperative, Platform Controls Operate Normally

Be sure key switch is in the appropriate position.

Be sure the Emergency Stop buttons are pulled out to the ON position.

Be sure the batteries are fully charged.

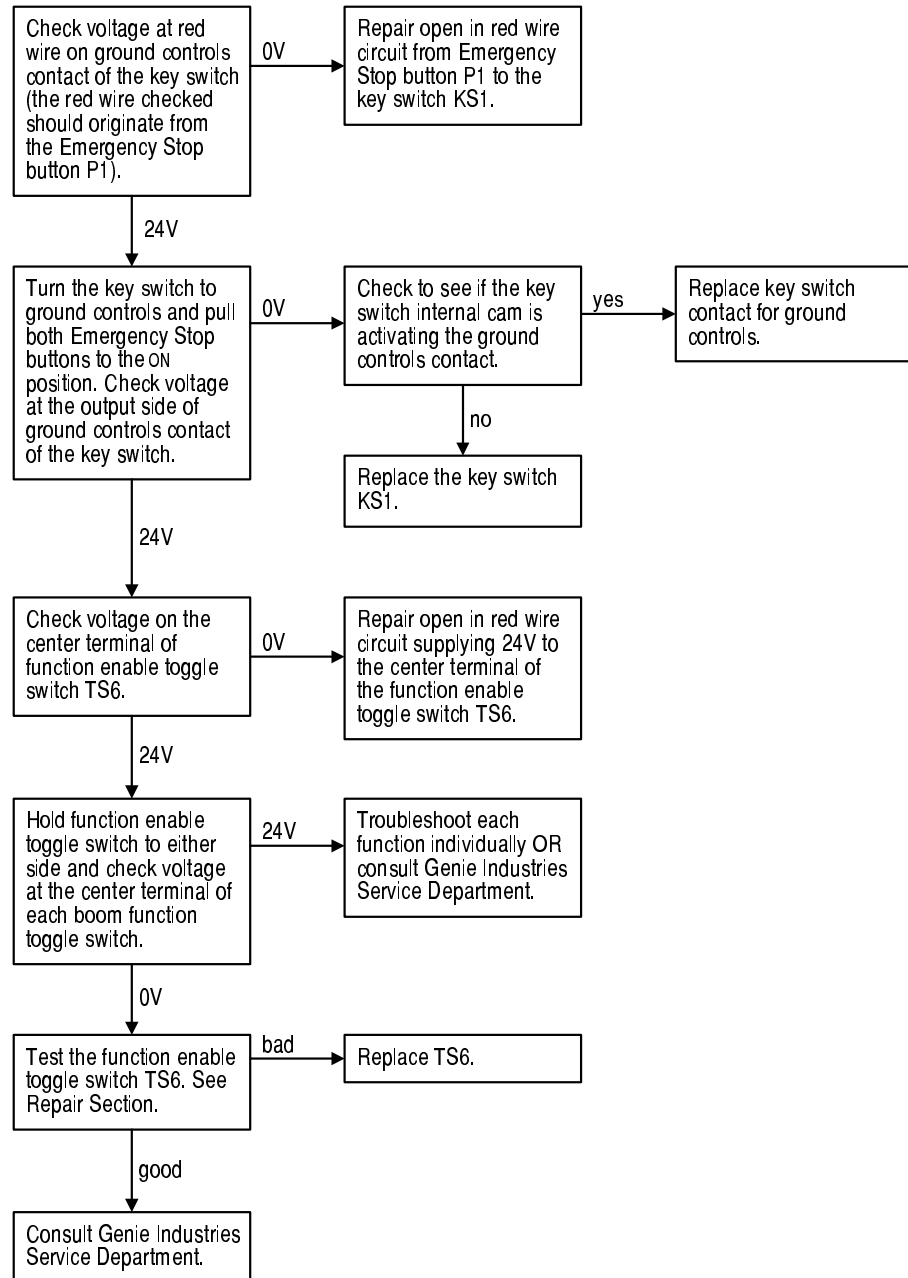

Chart 6

Platform Controls Inoperative, Ground Controls Operate Normally

Be sure key switch is in the appropriate position.

Be sure the Emergency Stop buttons are pulled up to the ON position.

Be sure the batteries are fully charged.

Be sure boom function speed controller is turned to maximum (rabbit symbol).

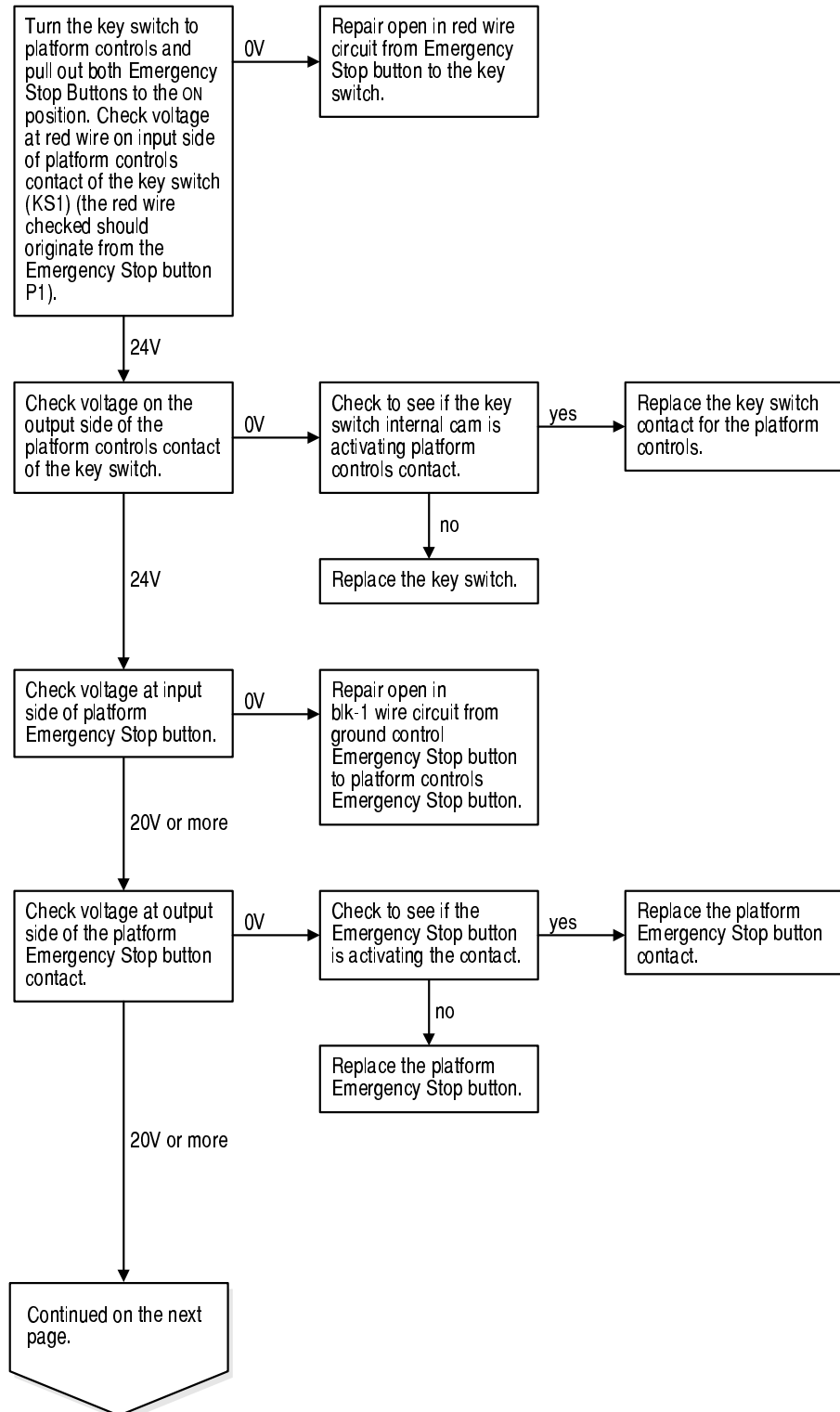

CHART 6

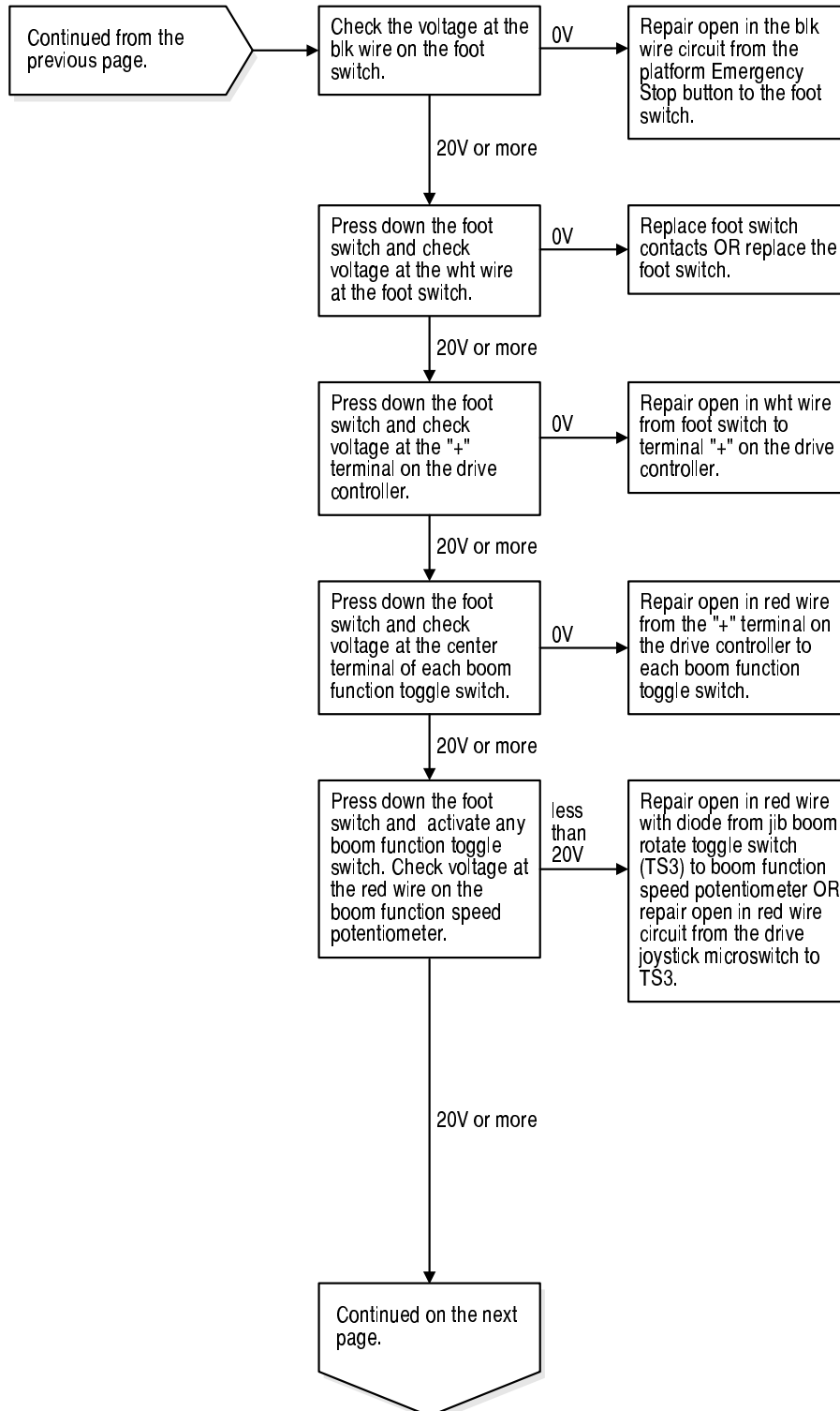

CHART 6

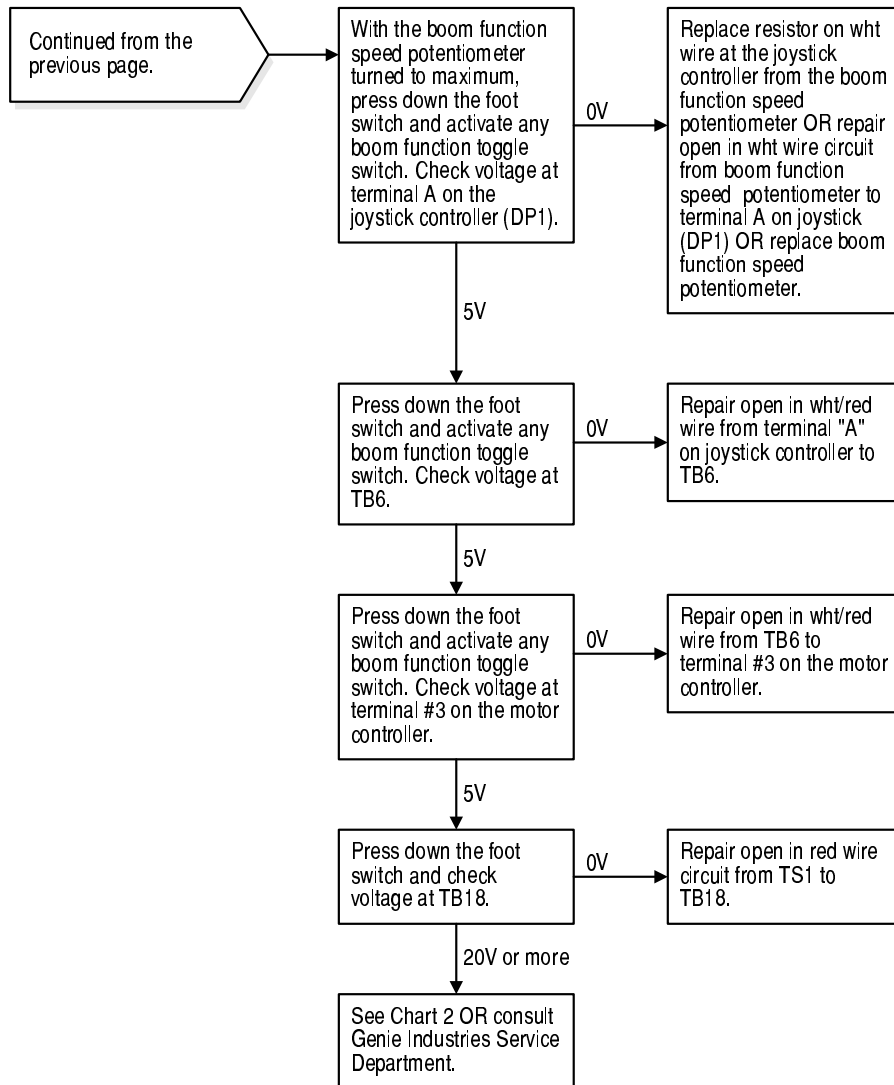

Chart 7

Boom Up Function Inoperative

Be sure all other functions operate normally.

Be sure the batteries are fully charged.

Be sure the battery packs are properly connected.

Be sure that the metal surfaces on the inside of the boom up valve coil and valve cartridge are clean and dry.

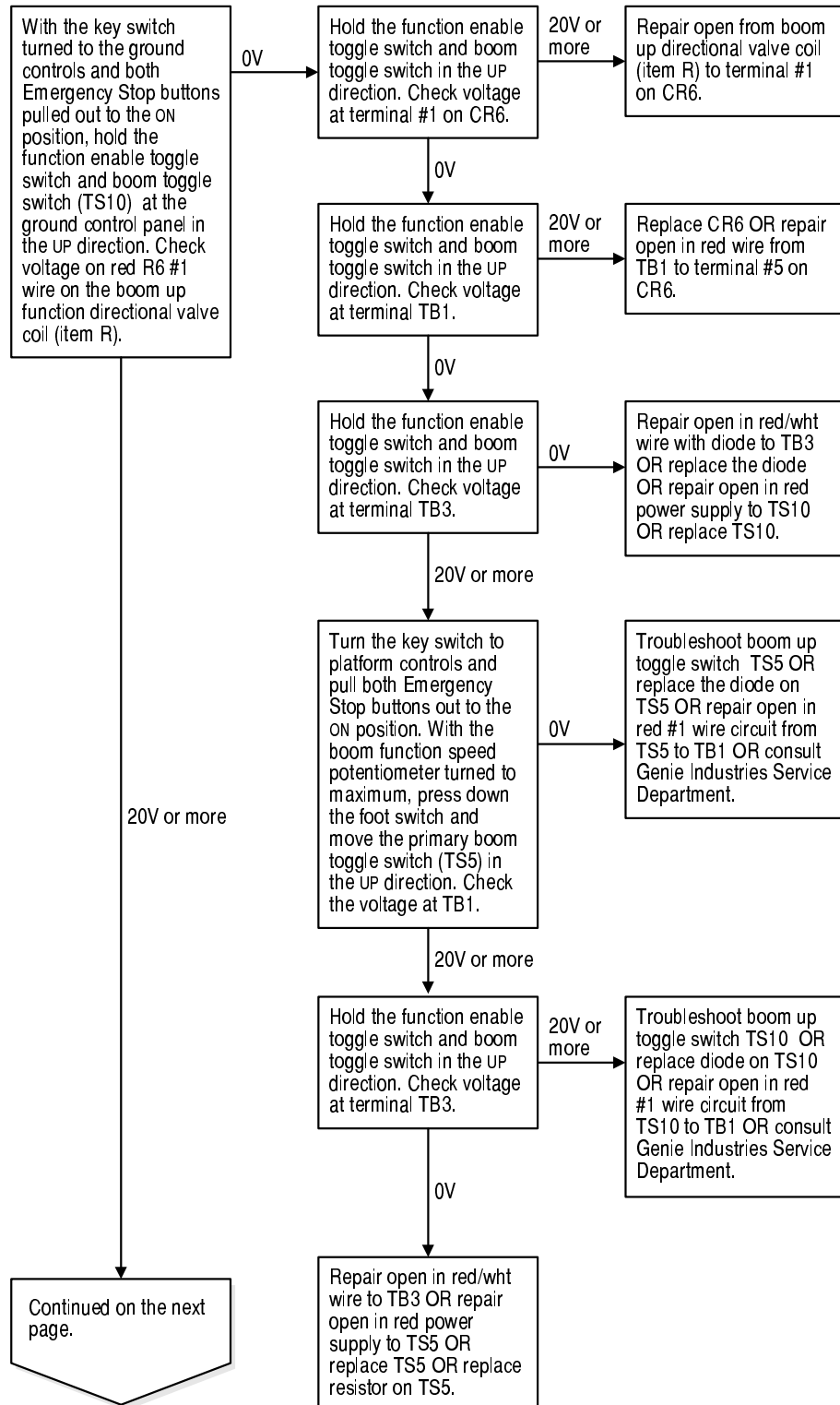

CHART 7

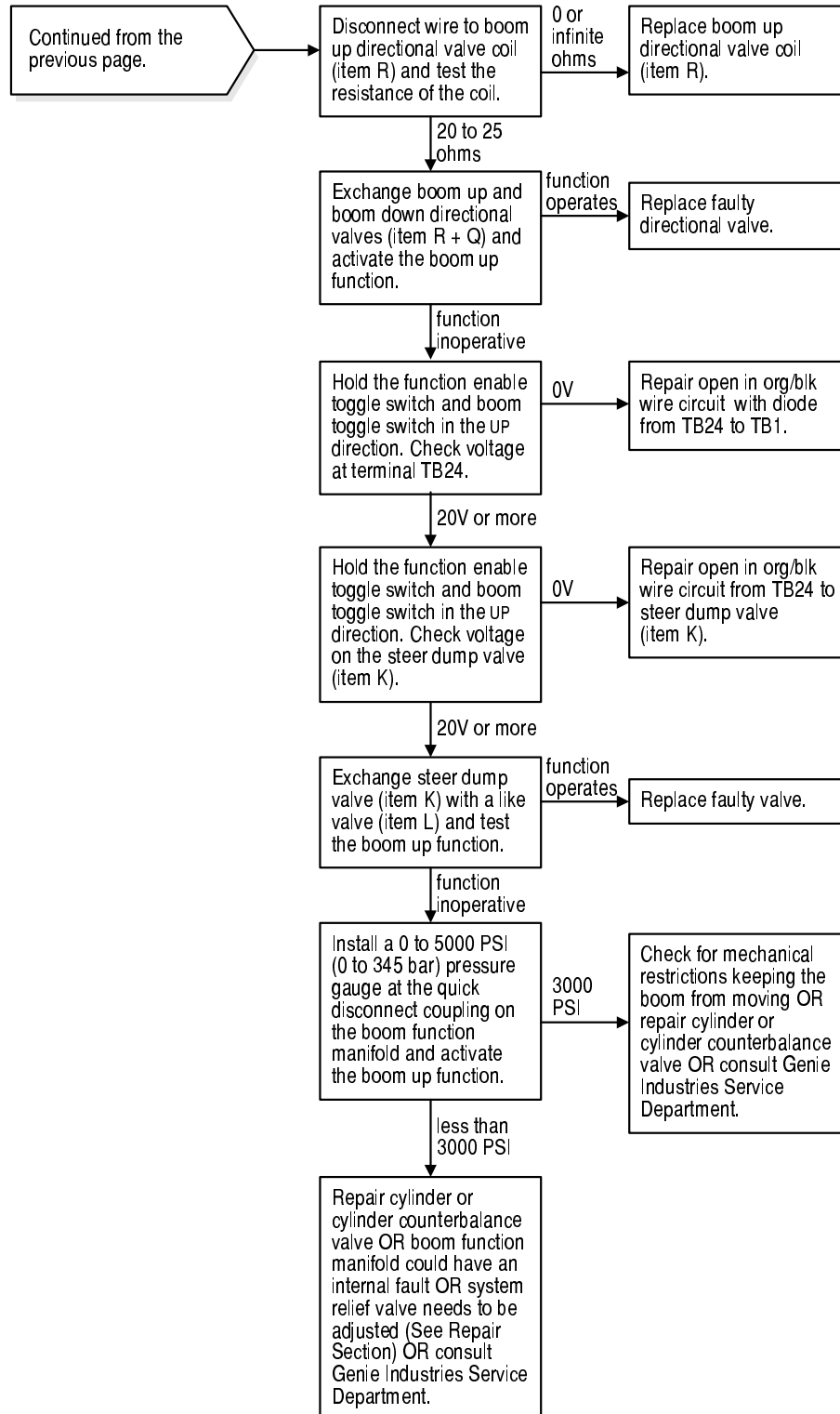

Chart 8

Boom Down Function Inoperative

Be sure all other functions operate normally.

Be sure the batteries are fully charged.

Be sure the battery packs are properly connected.

Be sure that the metal surfaces on the inside of the boom down valve coil and valve cartridge are clean and dry.

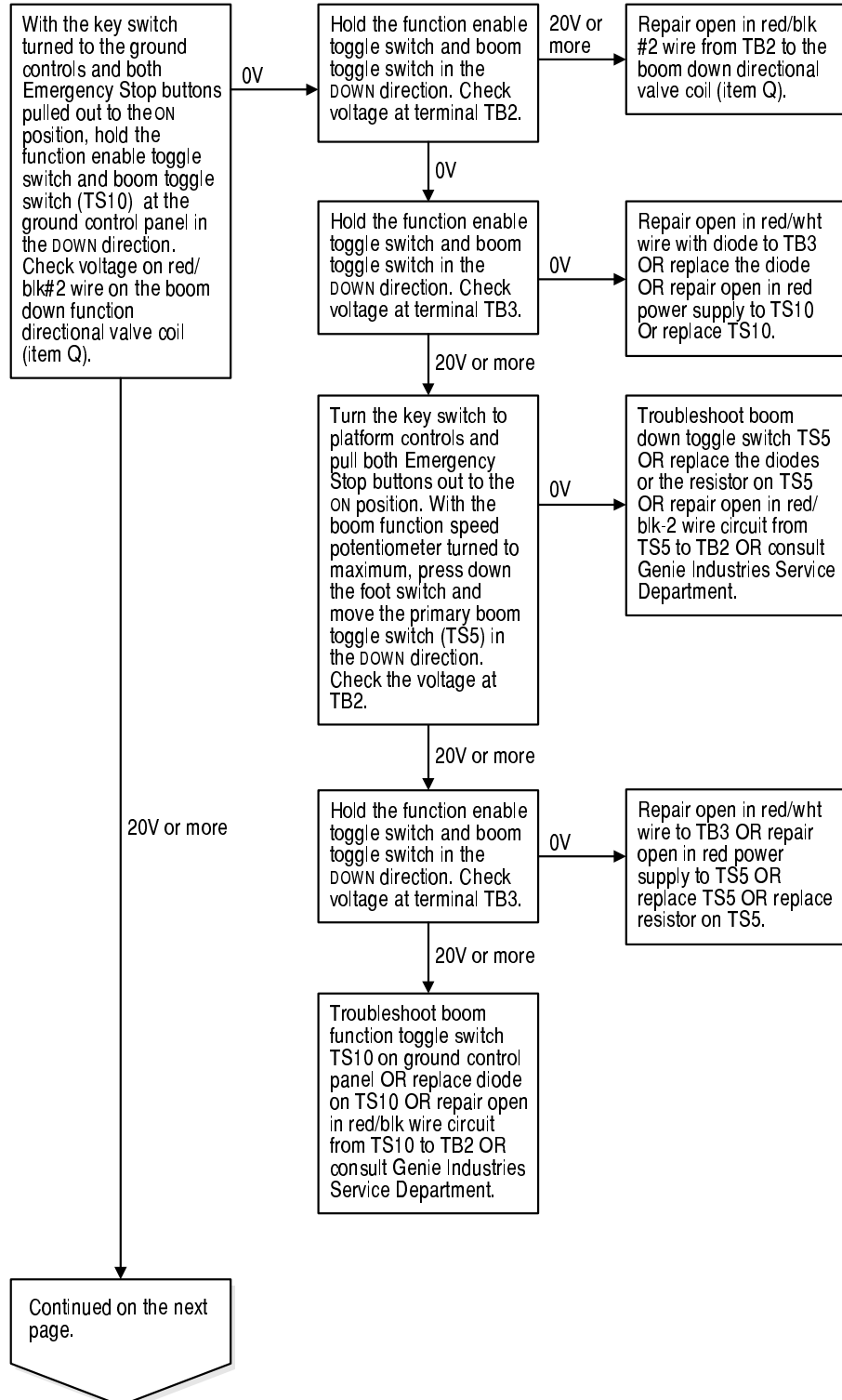

CHART 8

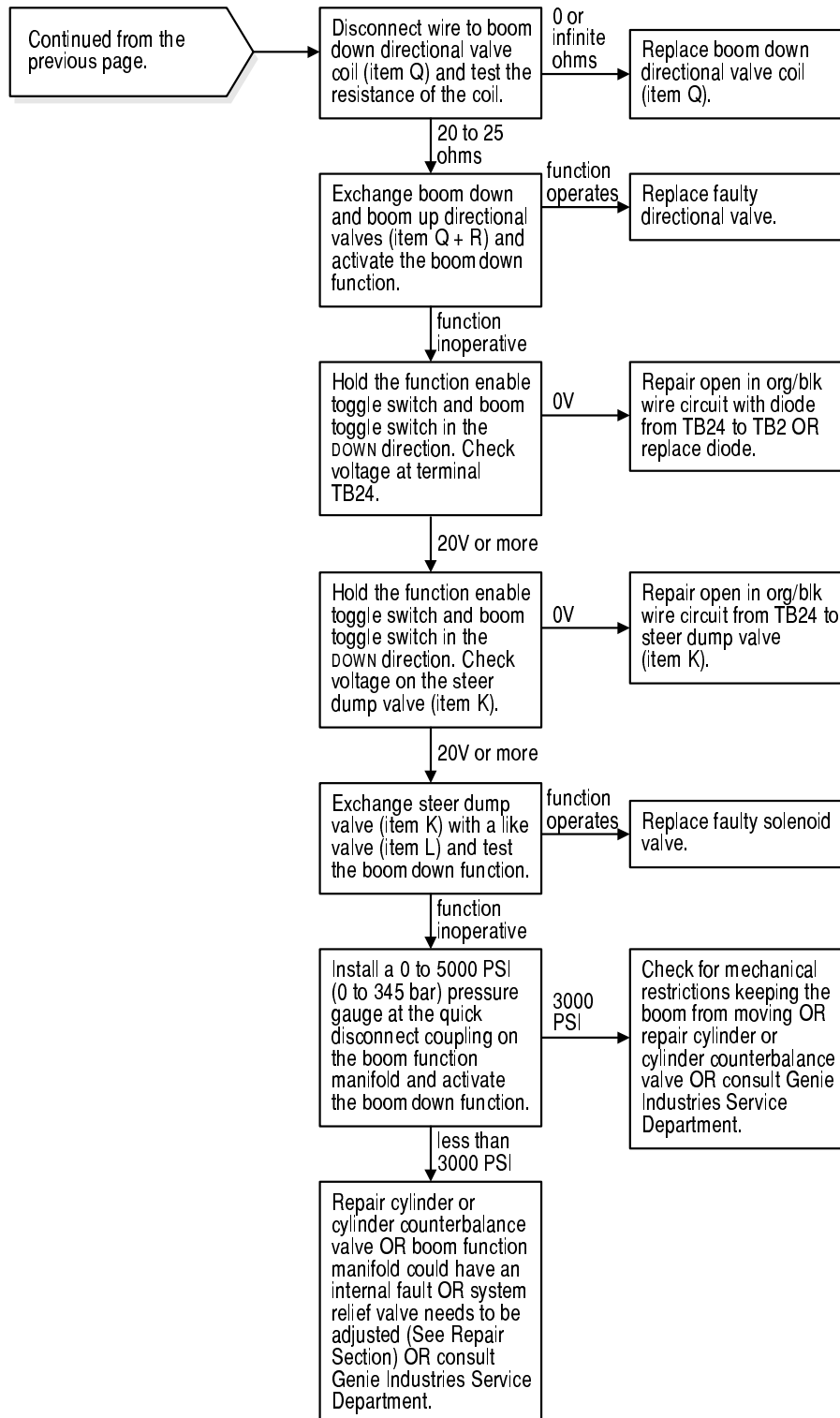

Chart 9

Jib Boom Up Function Inoperative

Be sure all other functions operate normally.

Be sure the batteries are fully charged.

Be sure the battery packs are properly connected.

Be sure that the metal surfaces on the inside of the jib boom up valve coil and valve cartridge are clean and dry.

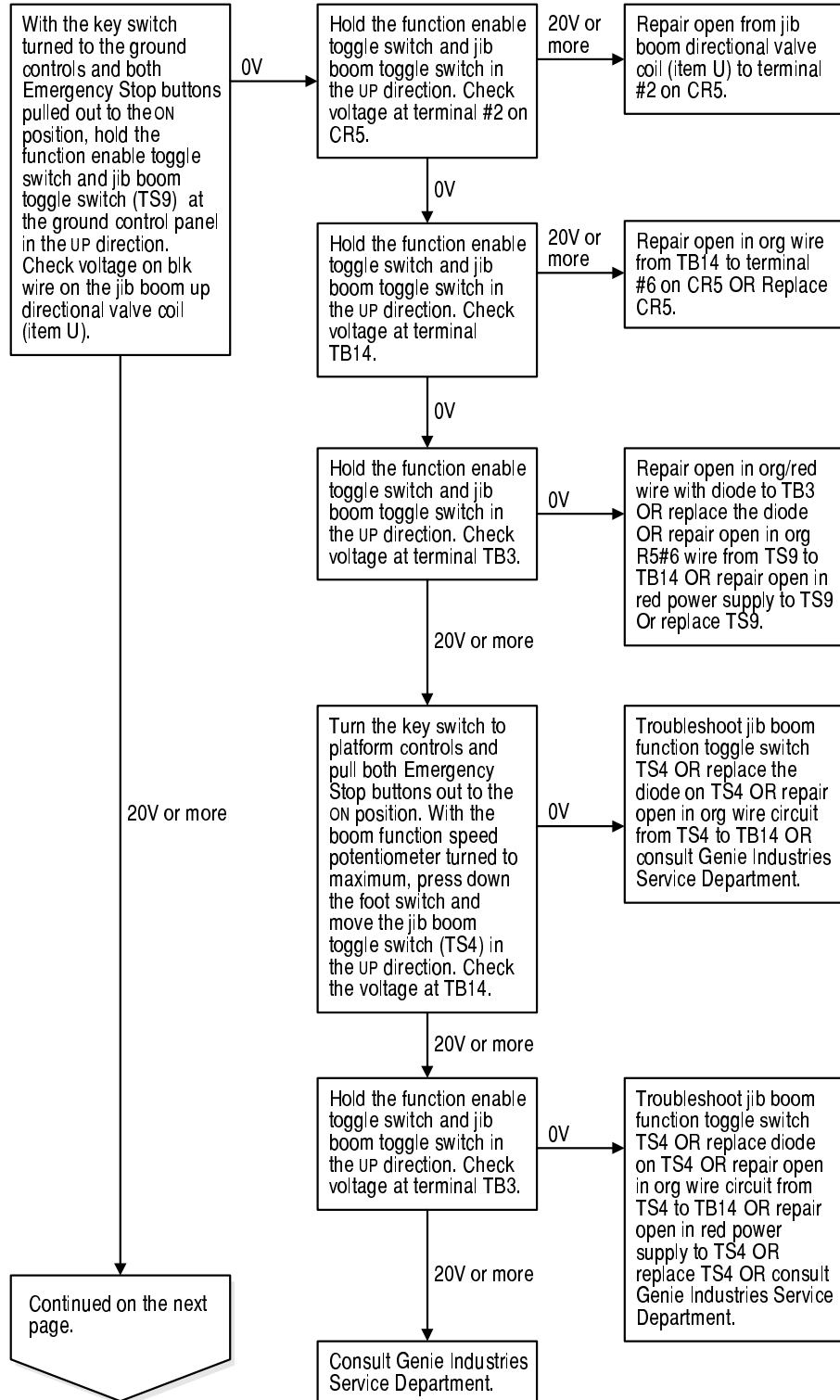

CHART 9

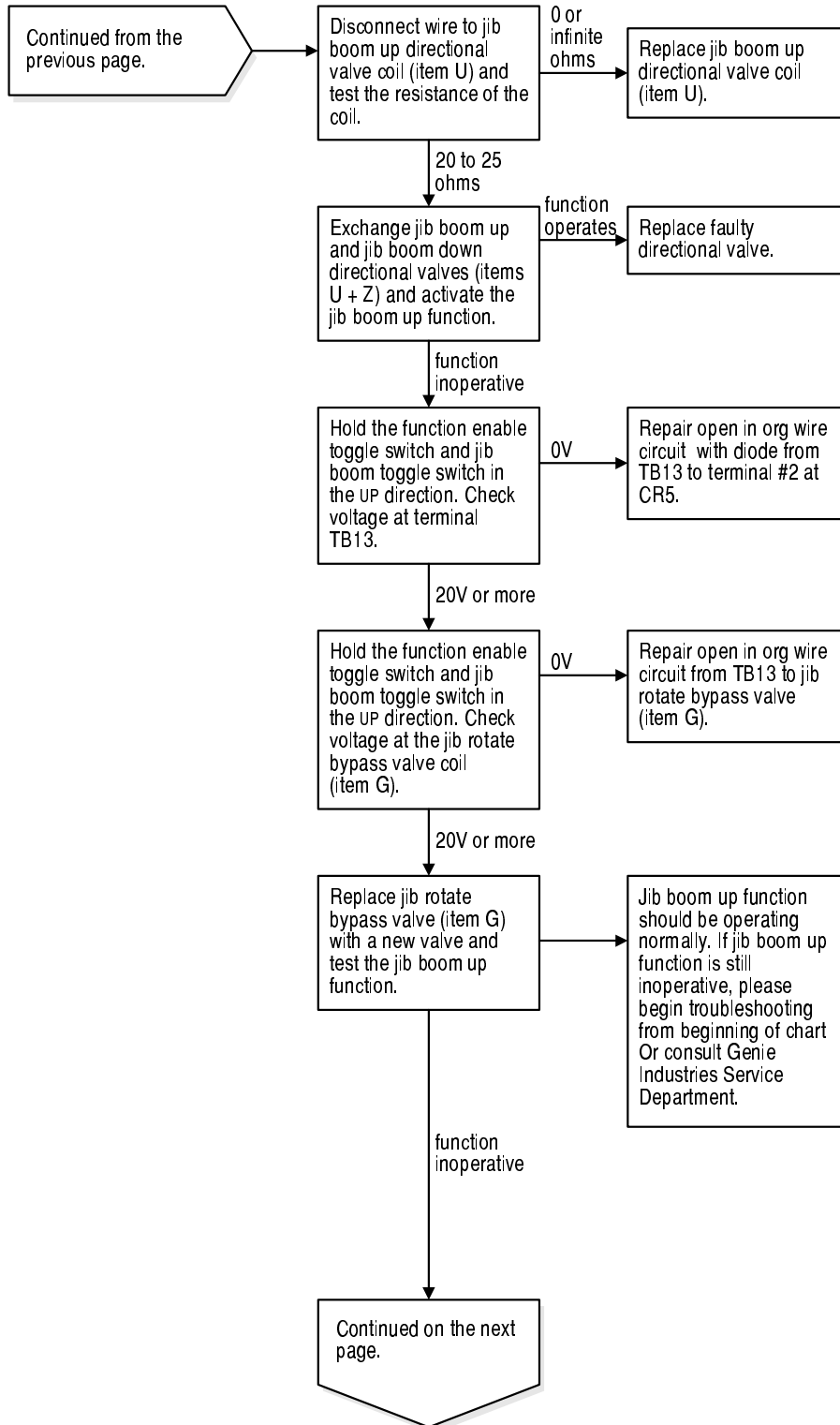

CHART 9

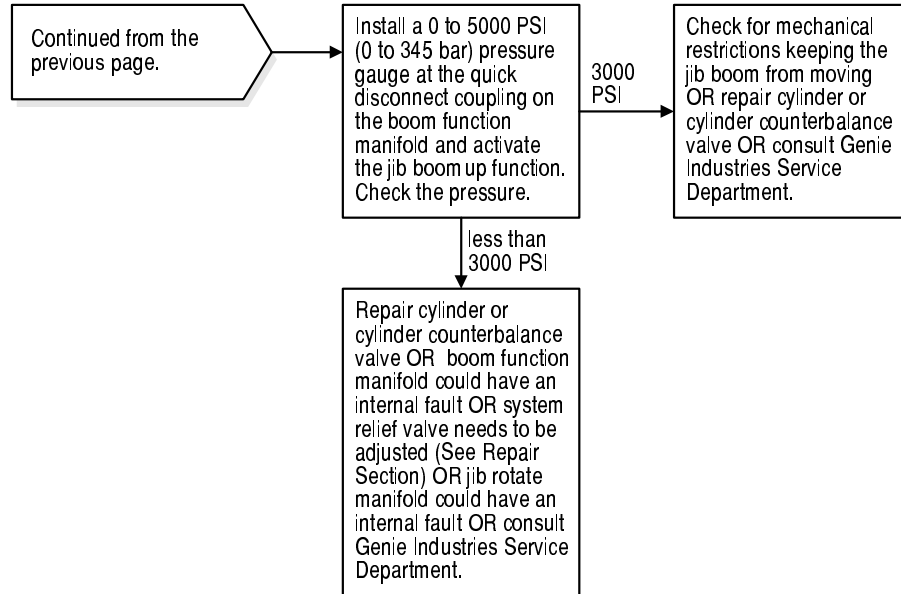

Chart 10

Jib Boom Down Function Inoperative

Be sure all other functions operate normally.

Be sure the batteries are fully charged.

Be sure the battery packs are properly connected.

Be sure that the metal surfaces on the inside of the jib boom down valve coil and valve cartridge are clean and dry.

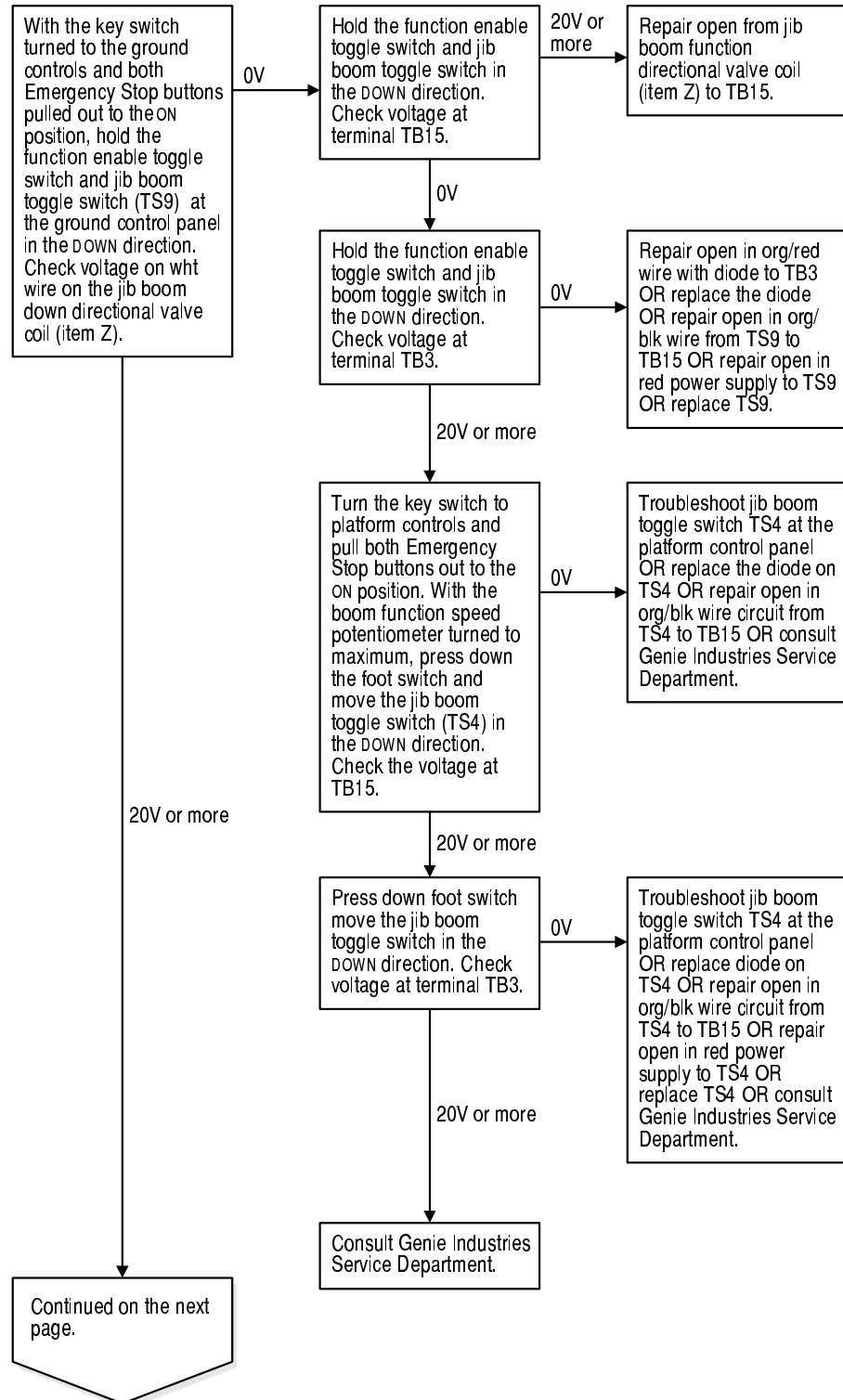

CHART 10

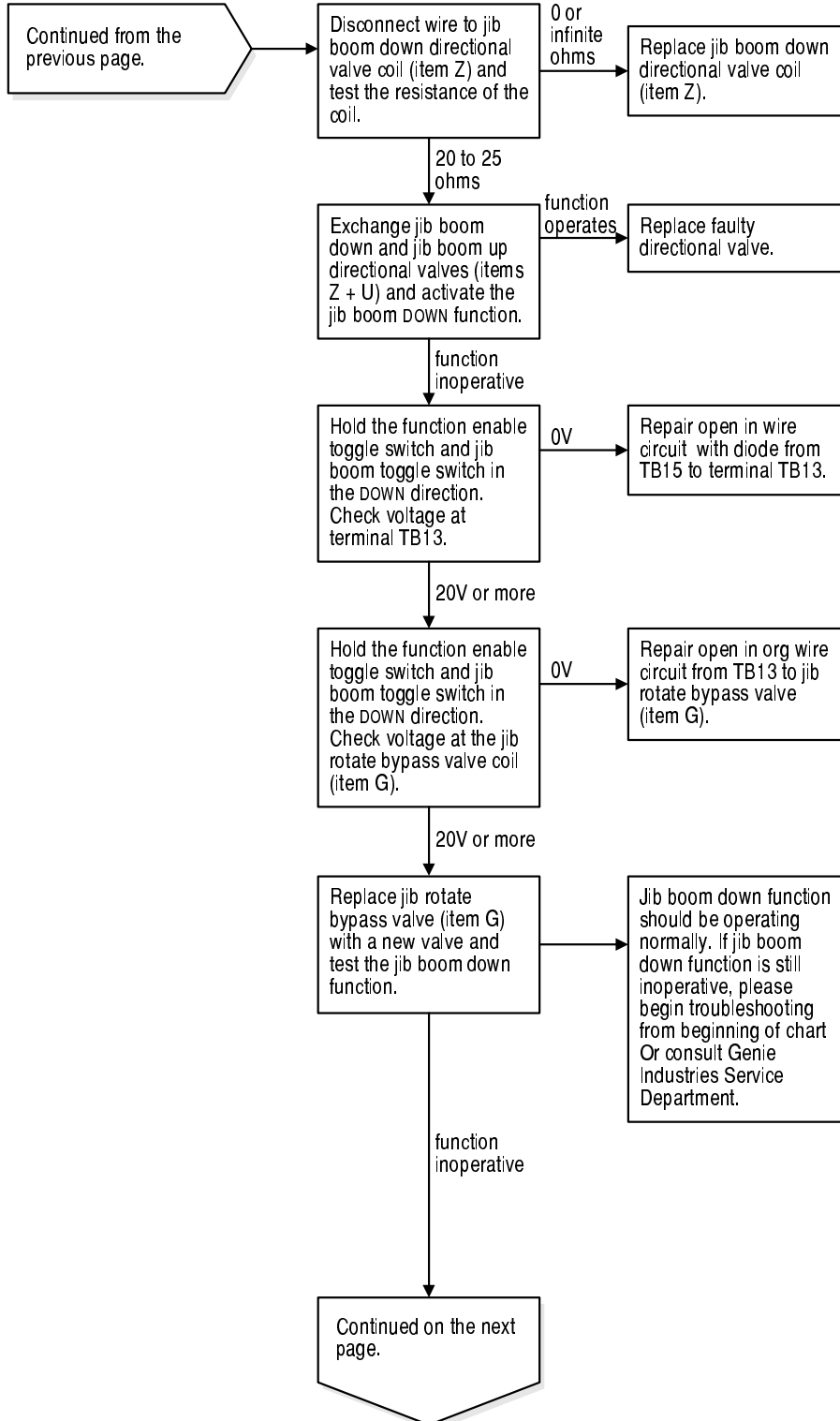

CHART 10

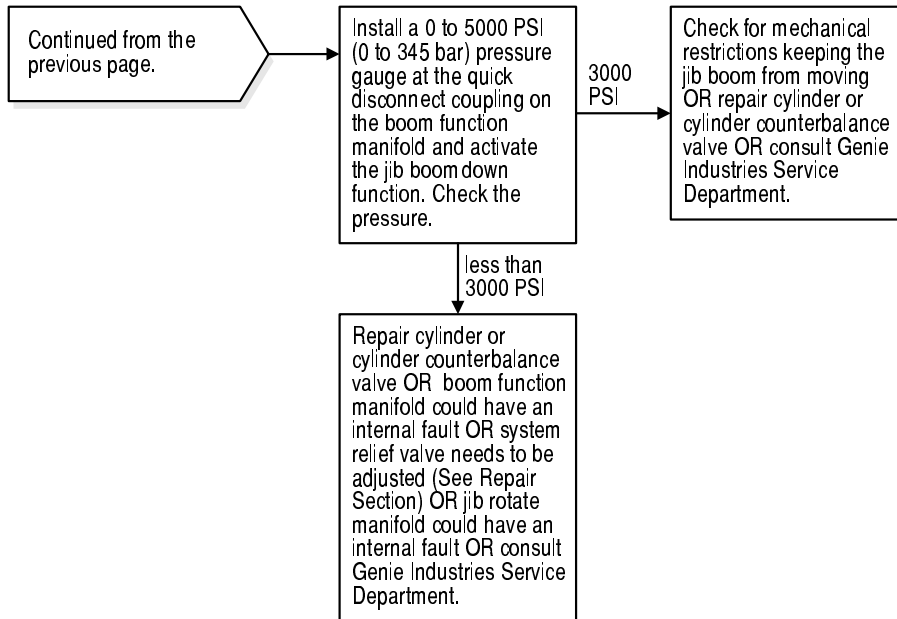

Chart 11

Jib Boom Rotate Left Function Inoperative

Be sure all other functions operate normally.

Be sure the batteries are fully charged.

Be sure the battery packs are properly connected.

Be sure that the metal surfaces on the inside of the jib boom rotate left valve coil and valve cartridge are clean and dry.

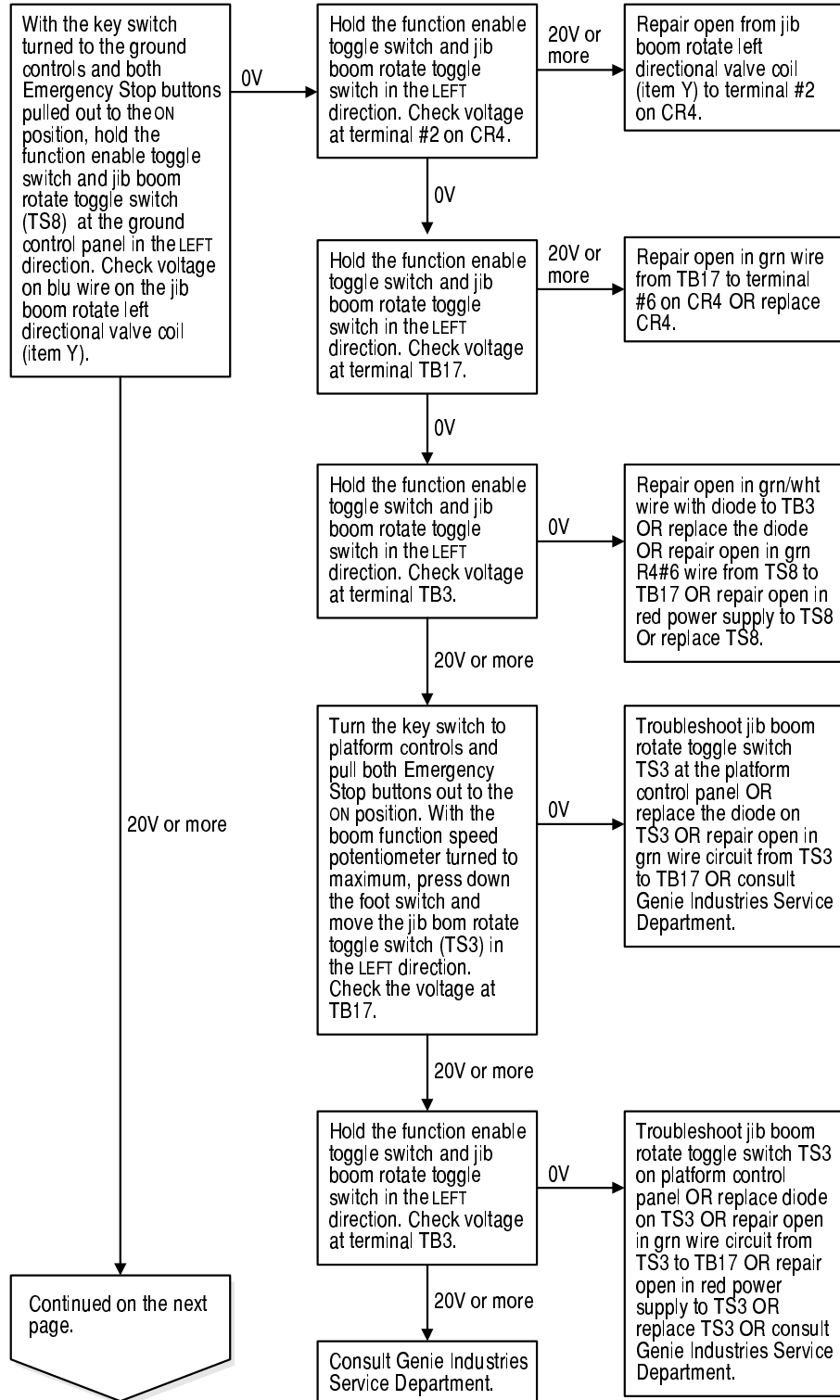

CHART 11

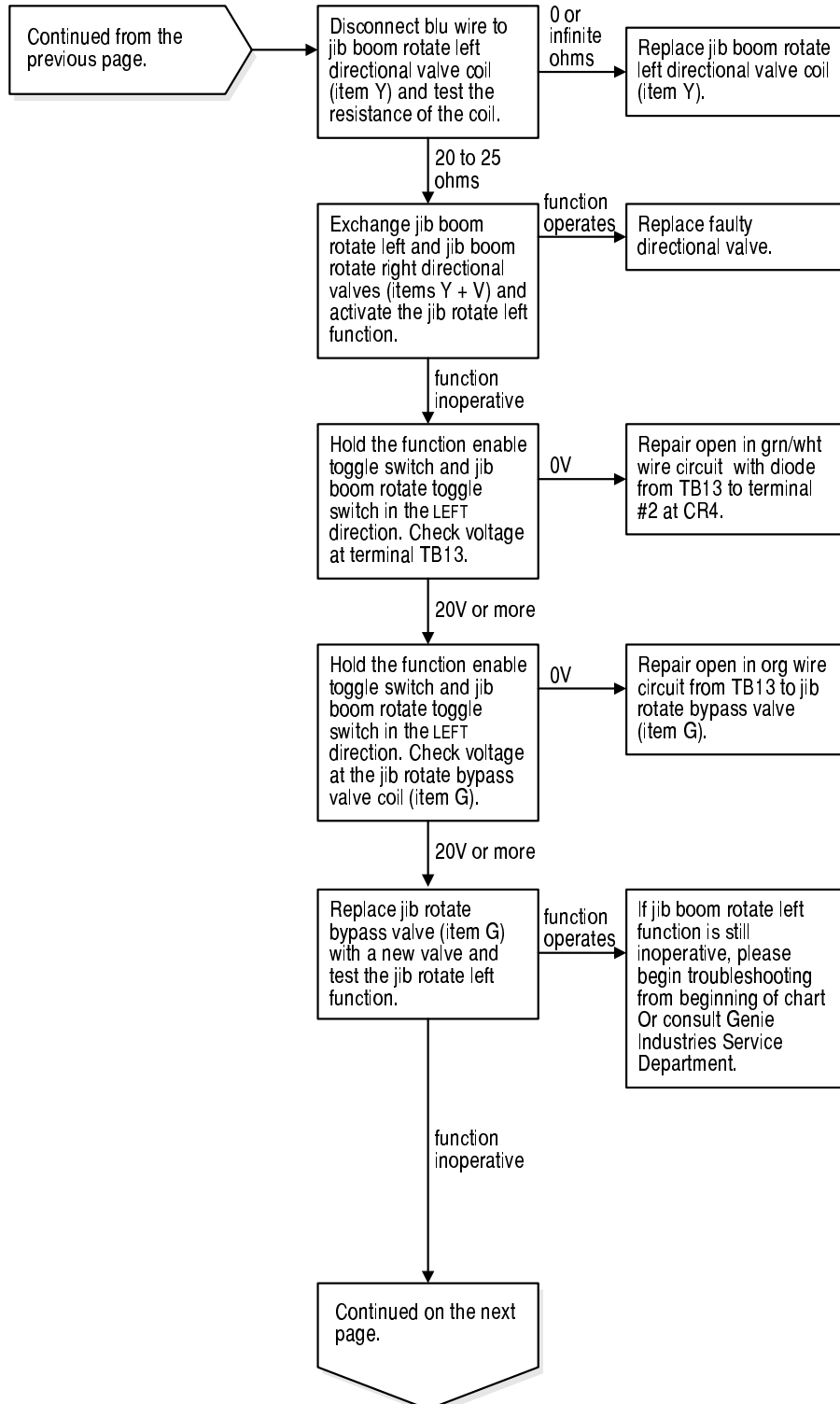

CHART 11

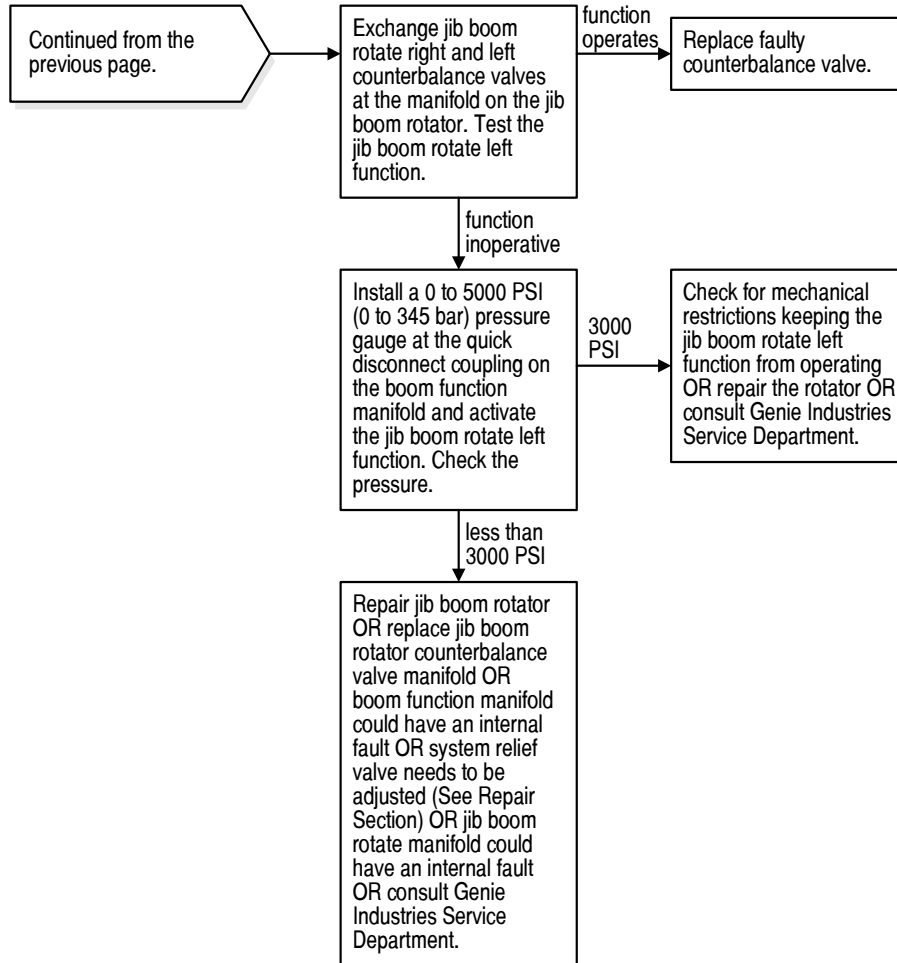

Chart 12

Jib Boom Rotate Right Function Inoperative

Be sure all other functions operate normally.

Be sure the batteries are fully charged.

Be sure the battery packs are properly connected.

Be sure that the metal surfaces on the inside of the jib boom rotate right valve coil and valve cartridge are clean and dry.

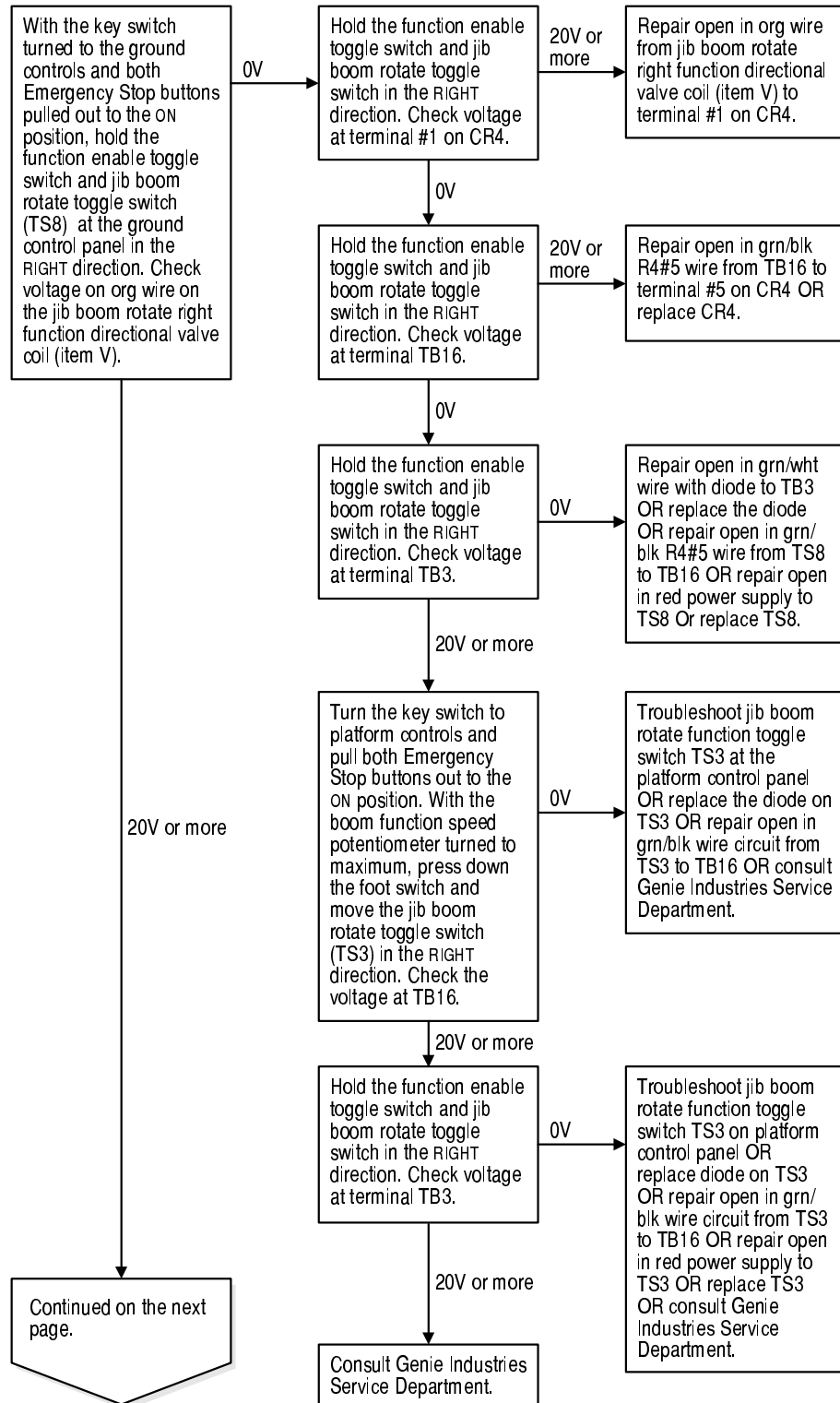

CHART 12

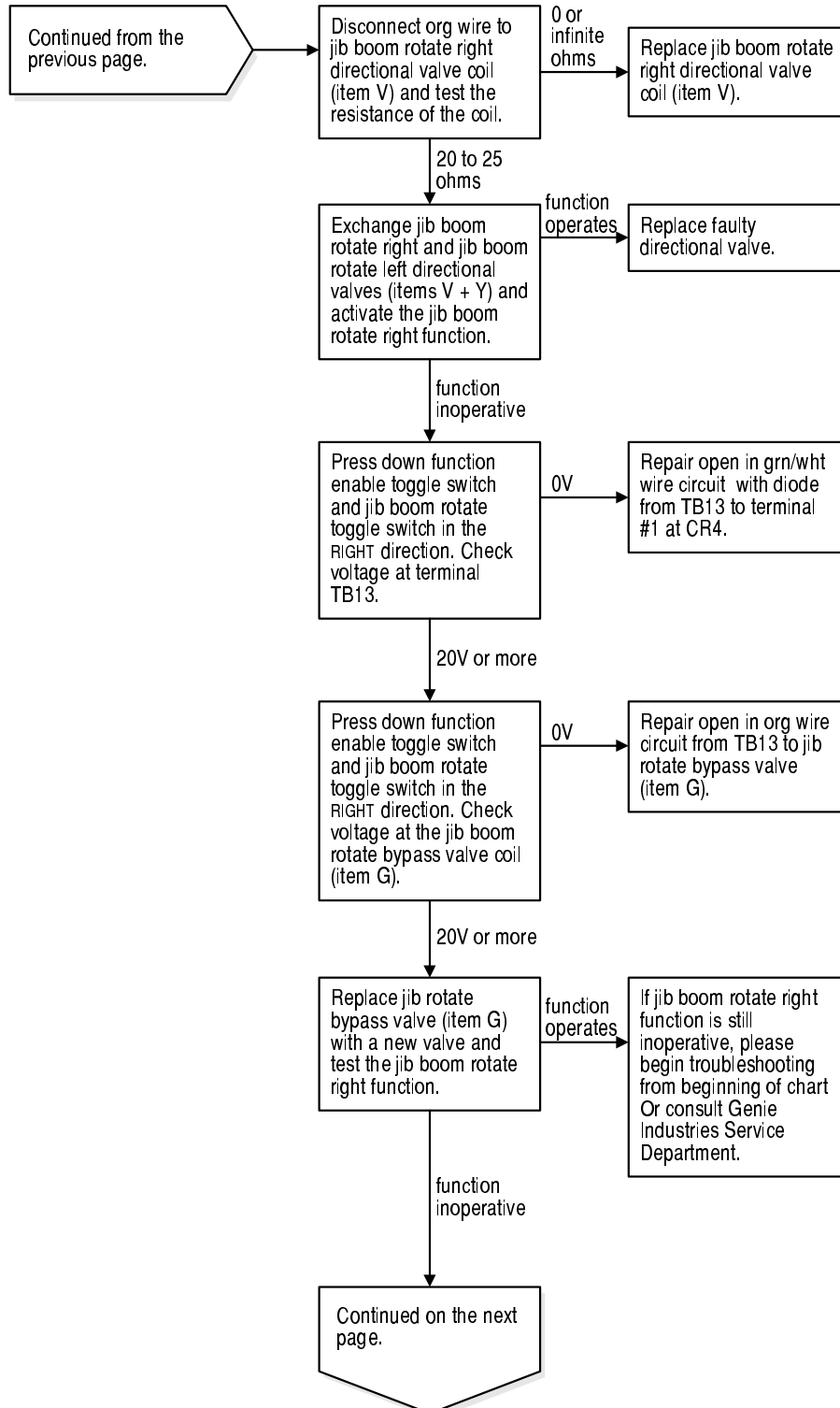

CHART 12

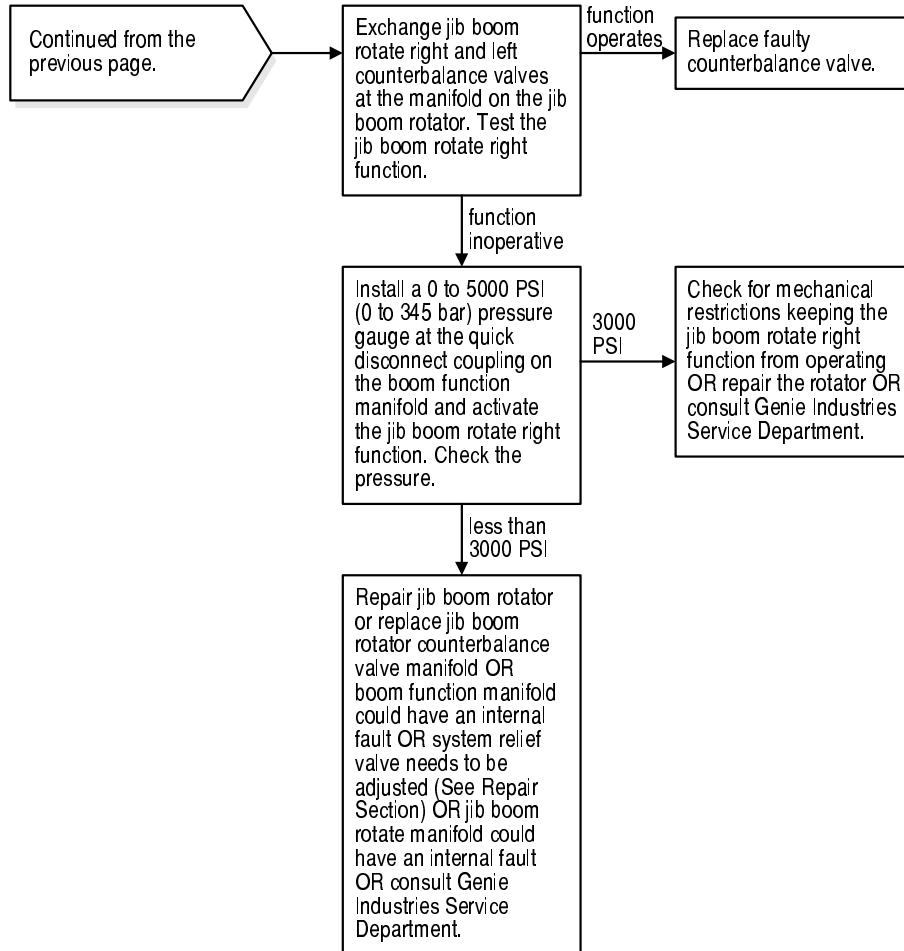

Chart 13

Steer Left Function Inoperative

Be sure all other functions operate normally.

Be sure the batteries are fully charged.

Be sure the battery packs are properly connected.

Be sure that the metal surfaces on the inside of the steer left valve coil and valve cartridge are clean and dry.

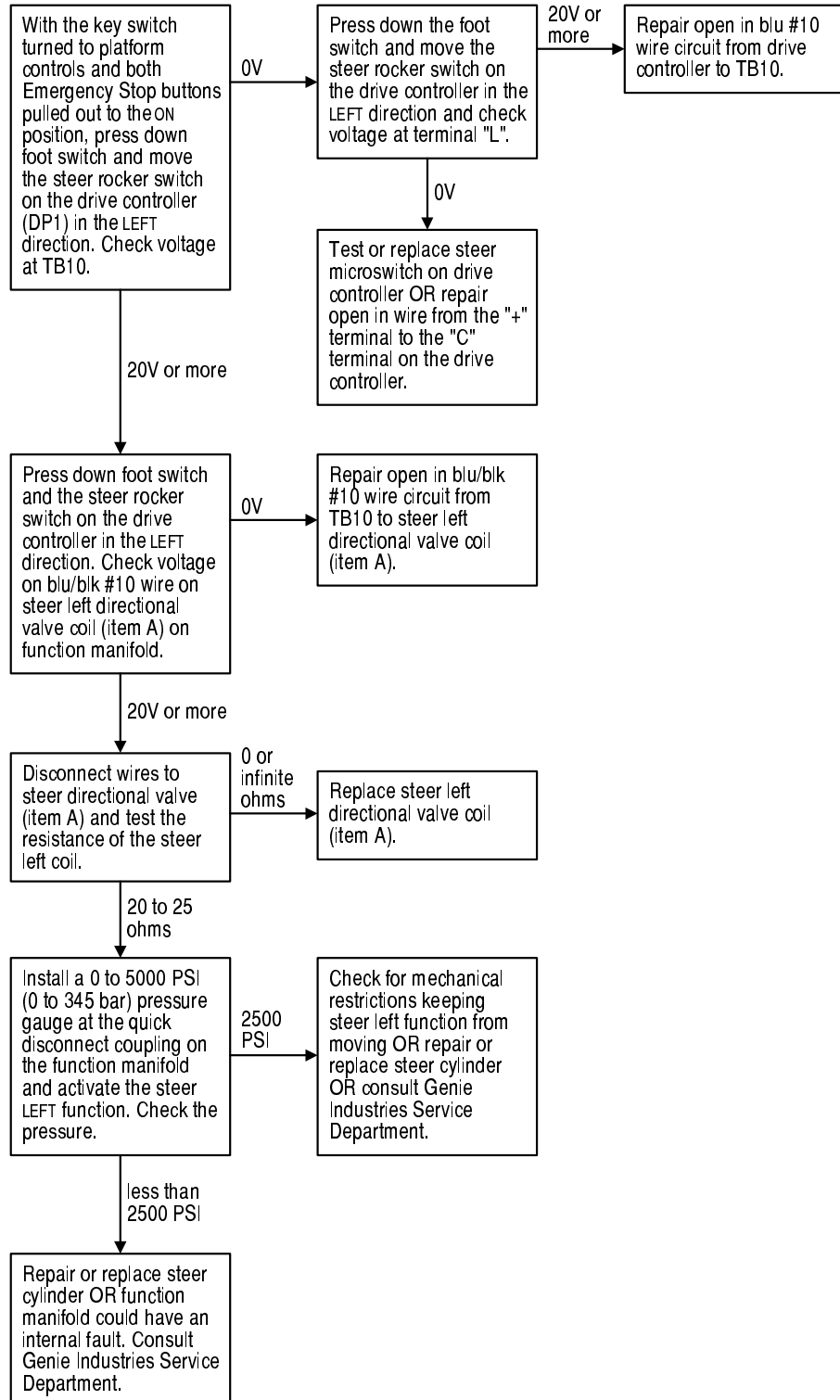

Chart 14

Steer Right Function Inoperative

Be sure all other functions operate normally.

Be sure the batteries are fully charged.

Be sure the battery packs are properly connected.

Be sure that the metal surfaces on the inside of the steer right valve coil and valve cartridge are clean and dry.

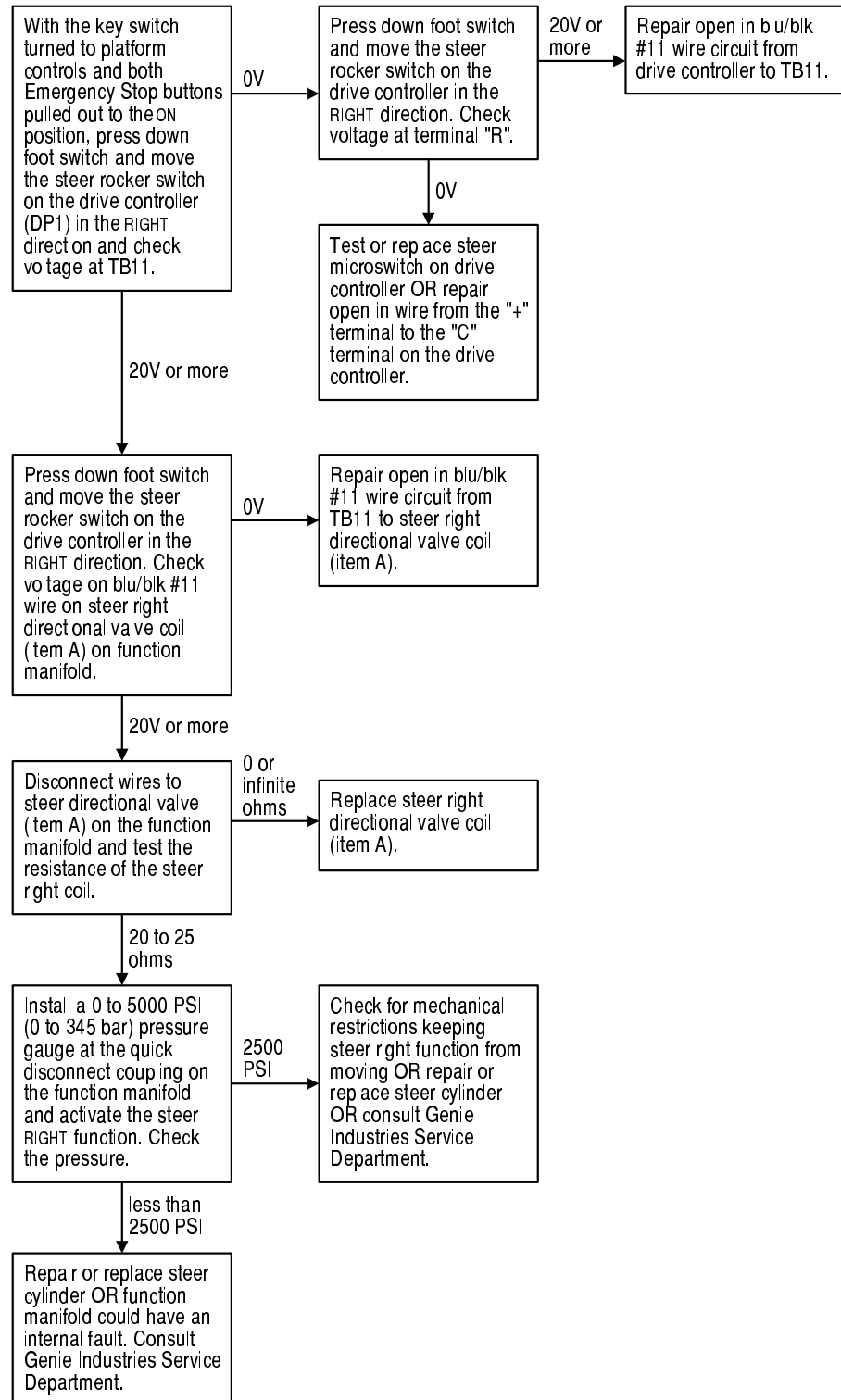

Chart 15

All Drive Functions Inoperative, all Other Functions Operate Normally

Be sure the unit is in the fully stowed position.

Be sure all other functions operate normally.

Be sure the batteries are fully charged.

Be sure the battery packs are properly connected.

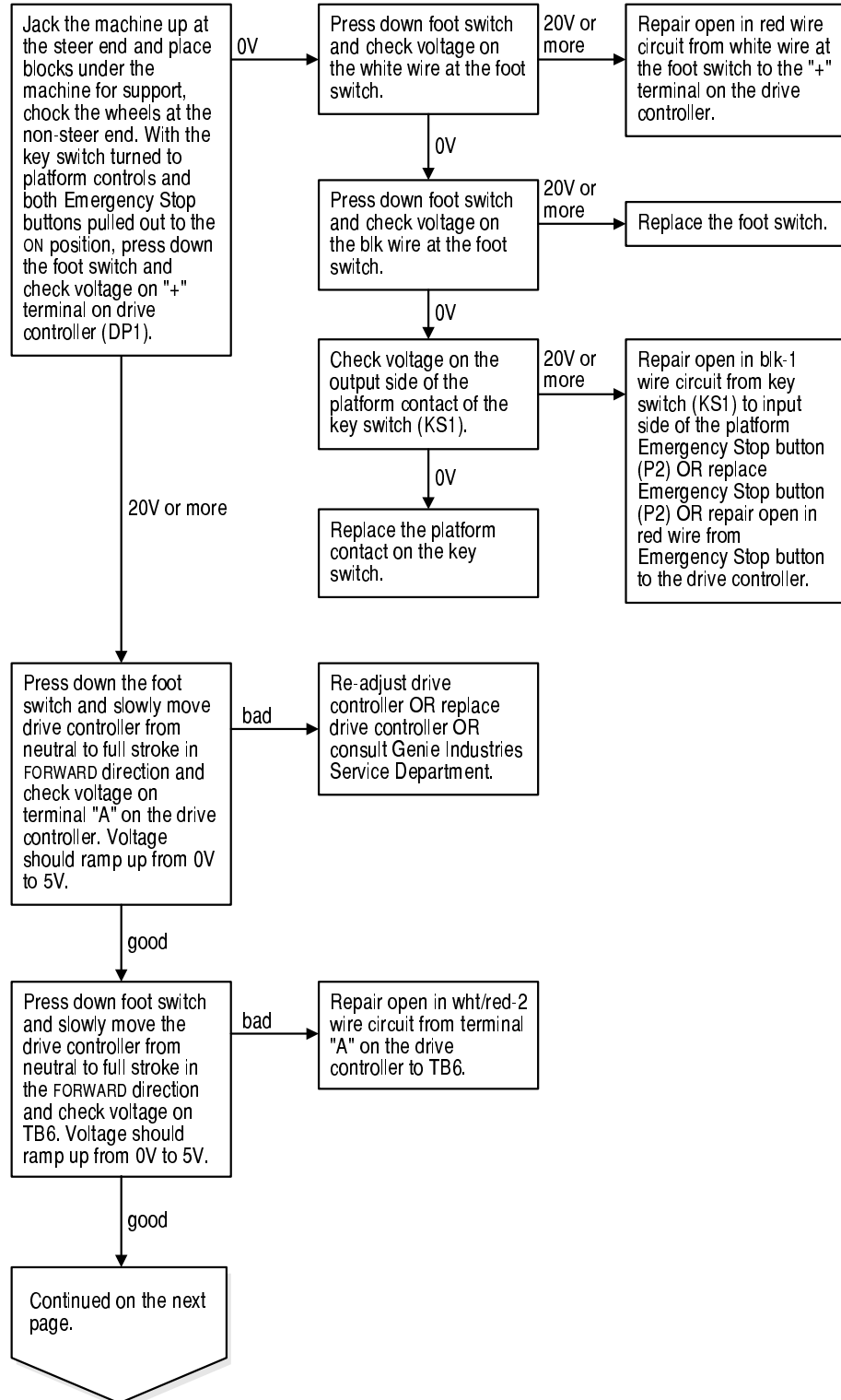

CHART 15

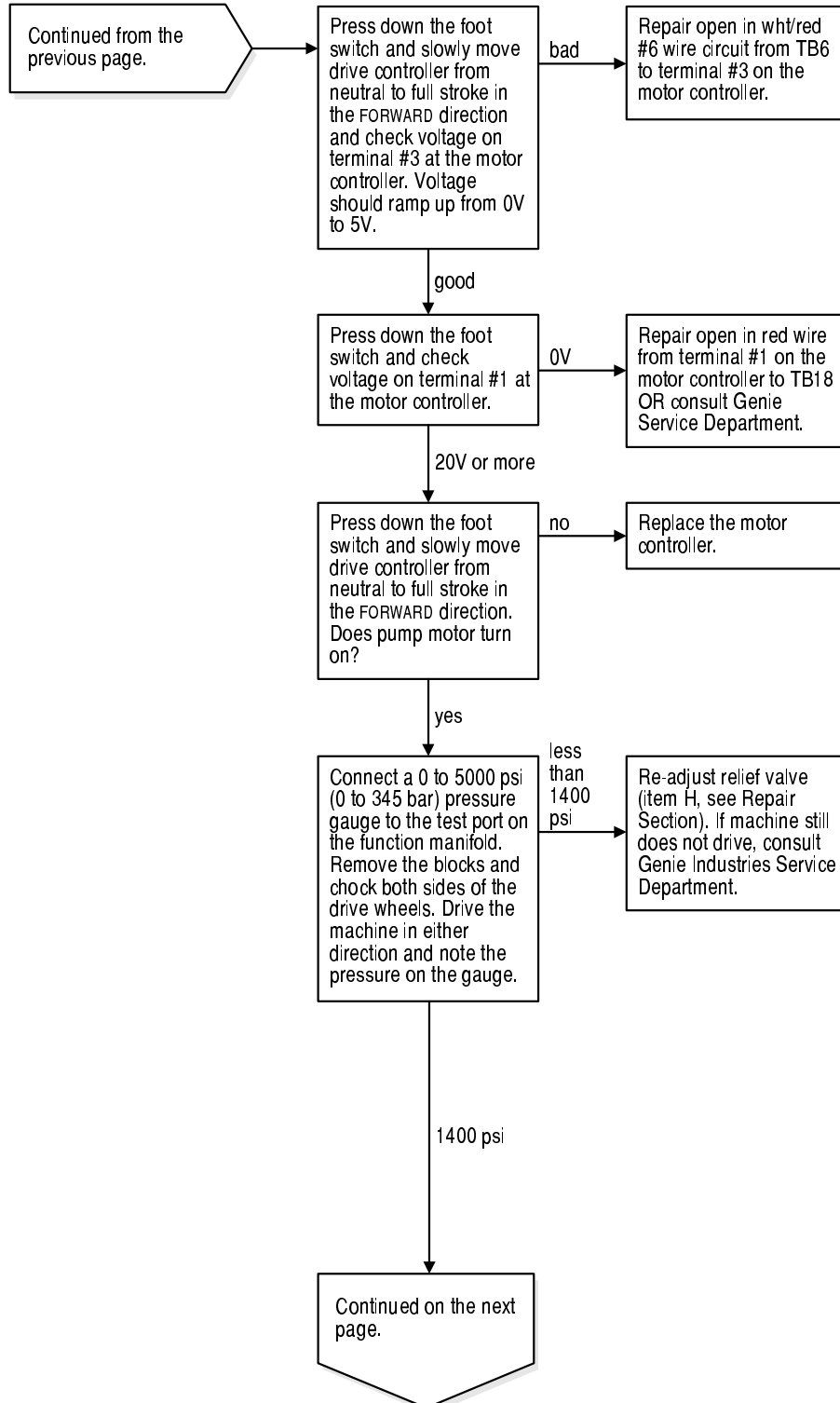

CHART 15

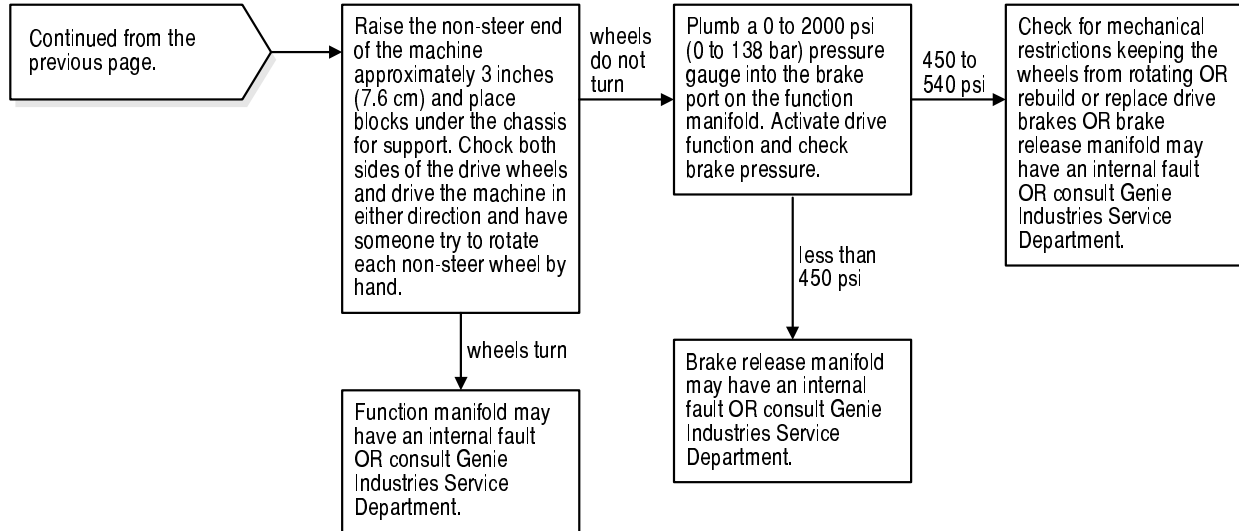

Chart 16

Drive Forward Function Inoperative

Be sure key switch is in the appropriate position.

Be sure the unit is in the fully stowed position.

Be sure all other functions operate normally.

Be sure the batteries are fully charged.

Be sure the battery packs are properly connected.

Be sure that the metal surfaces on the inside of the drive forward valve coil and valve cartridge are clean and dry.

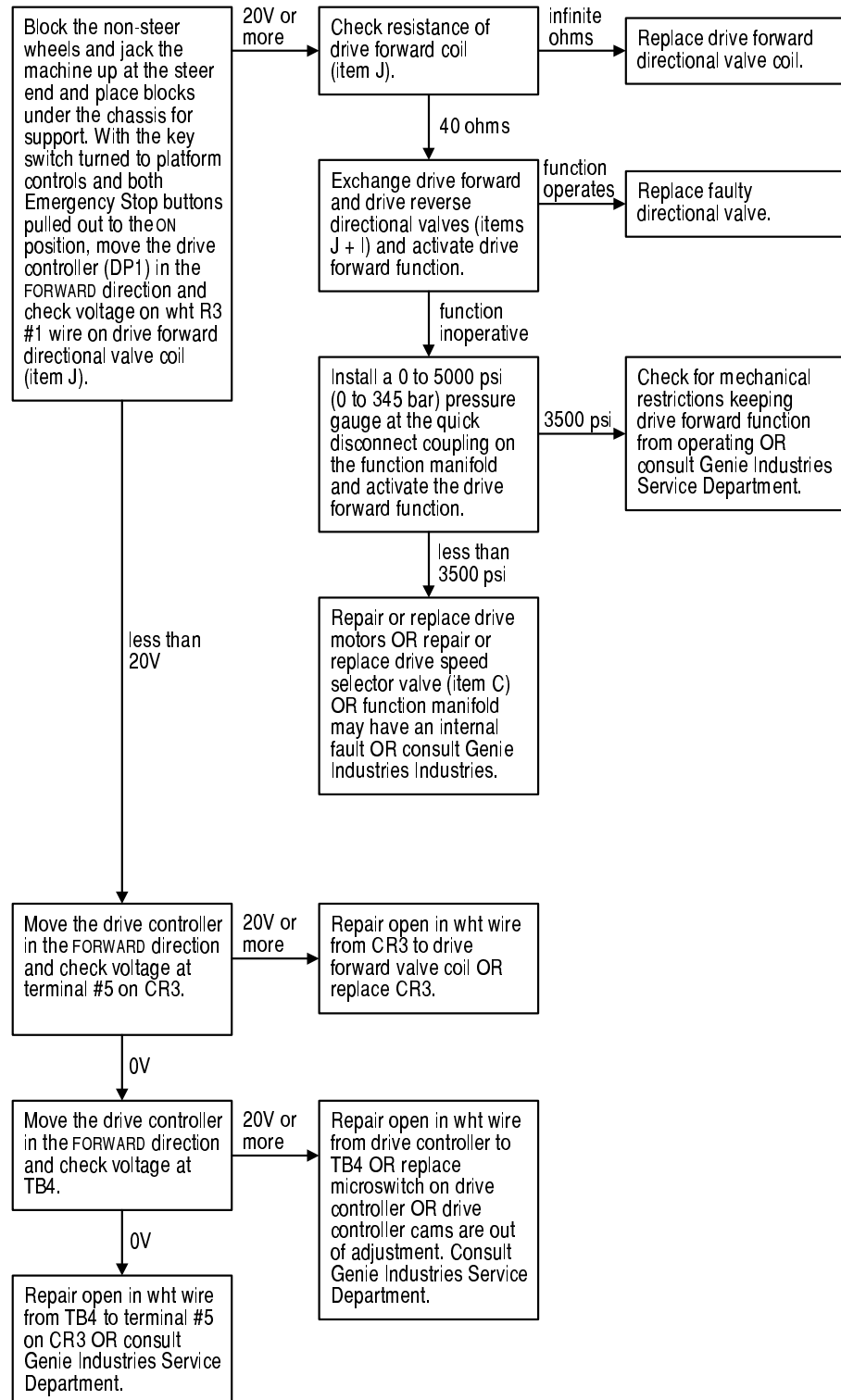

Chart 17

Drive Reverse Function Inoperative

Be sure key switch is in the appropriate position.

Be sure the unit is in the fully stowed position.

Be sure all other functions operate normally.

Be sure the batteries are fully charged.

Be sure the battery packs are properly connected.

Be sure that the metal surfaces on the inside of the drive reverse valve coil and valve cartridge are clean and dry.

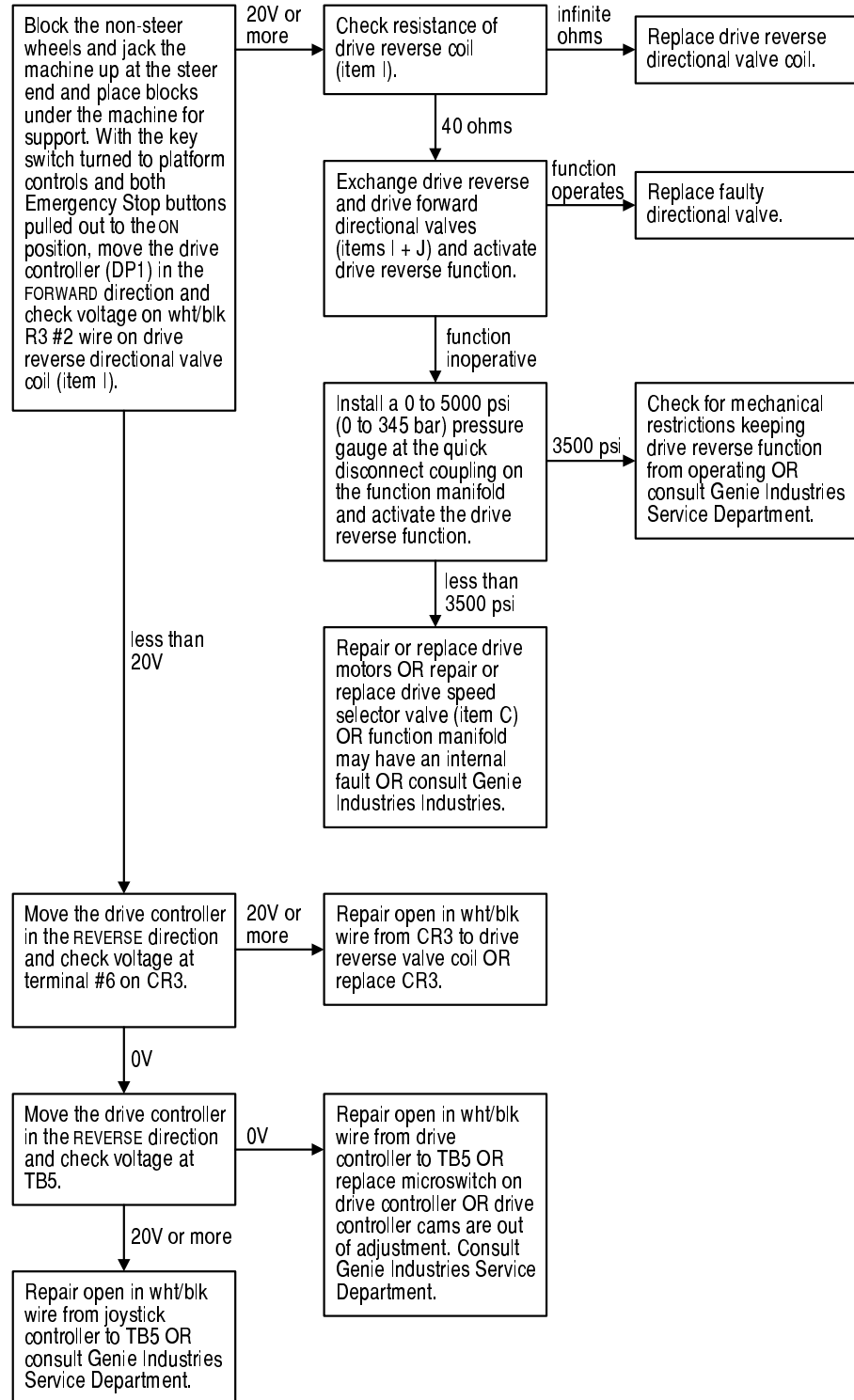

Chart 18

Machine Will Not Drive At Full Speed

Be sure key switch is in the appropriate position.

Be sure the unit is in the fully stowed position.

Be sure all other functions operate normally.

Be sure the batteries are fully charged.

Be sure the battery packs are properly connected.

Be sure the boom limit switch (LS1) is being activated when the boom is in the stowed position.

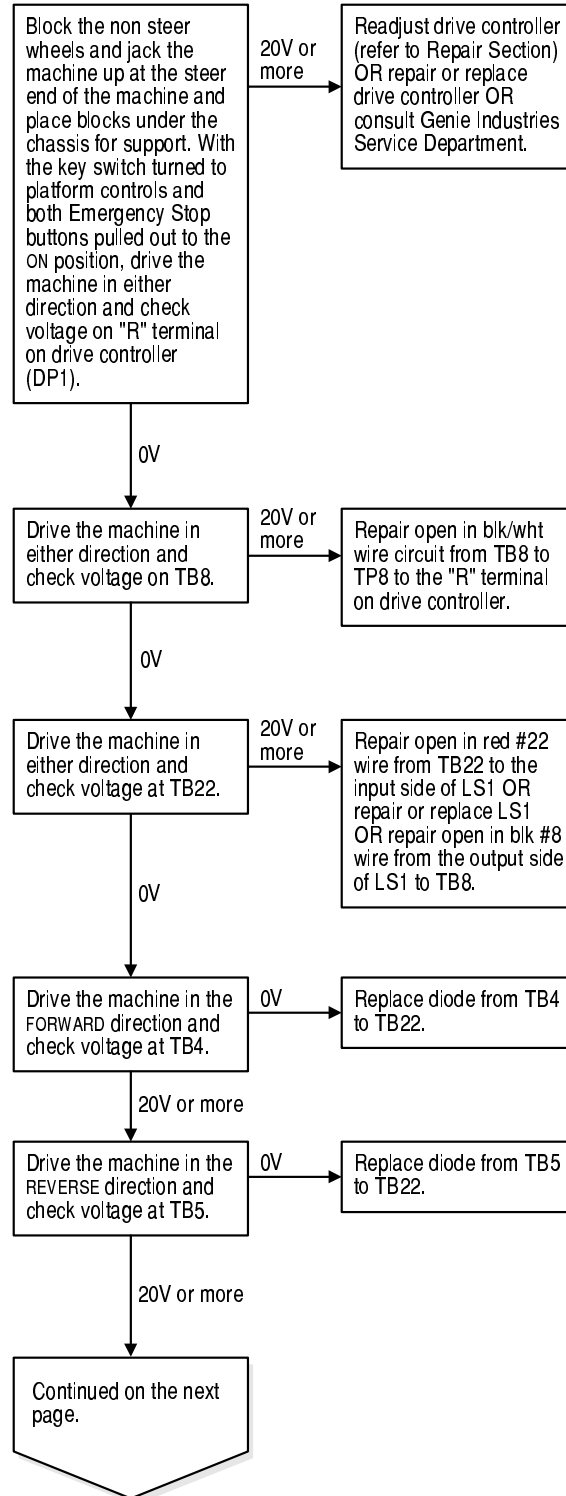

CHART 18

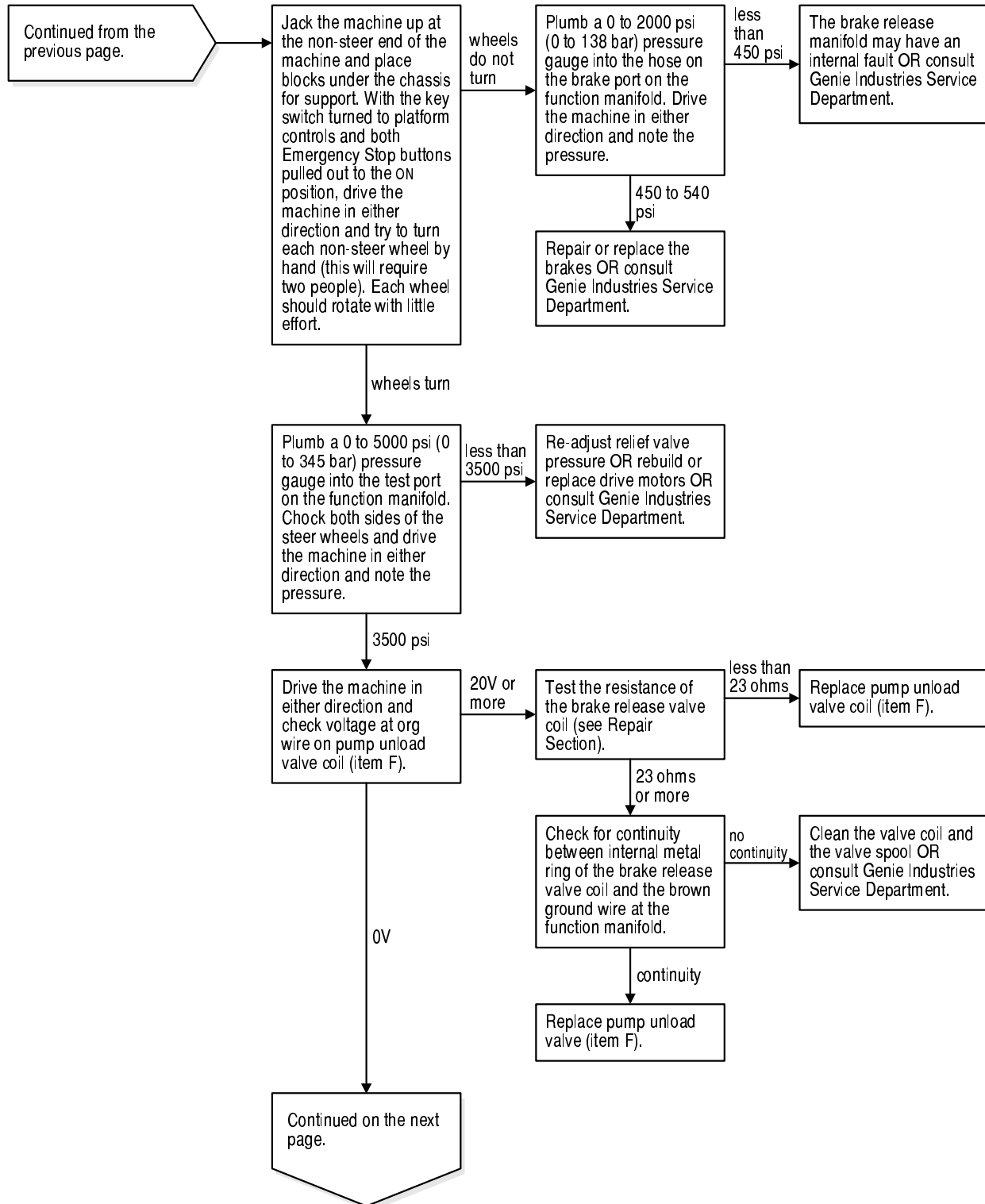

CHART 18

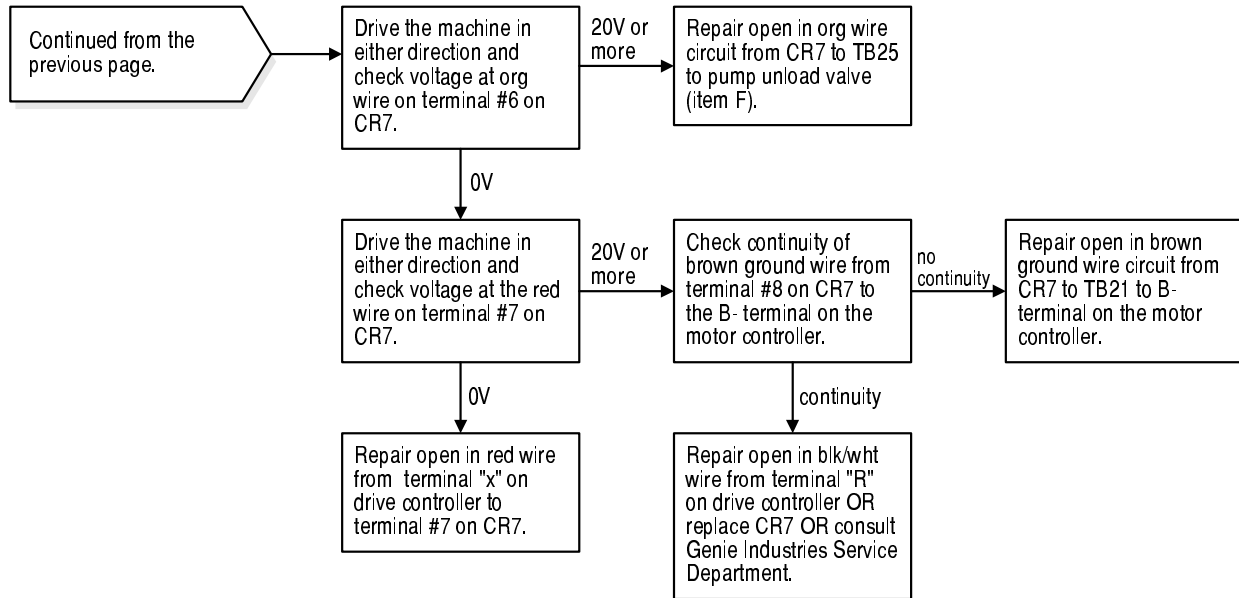

Chart 19

Machine Drives At Full Speed With Platform Raised

Remove the machine from service immediately.

Be sure the wiring to the limit switch is intact and shows no sign of damage or corrosion.

Be sure the boom limit switch is not being activated when the boom is in the raised position.

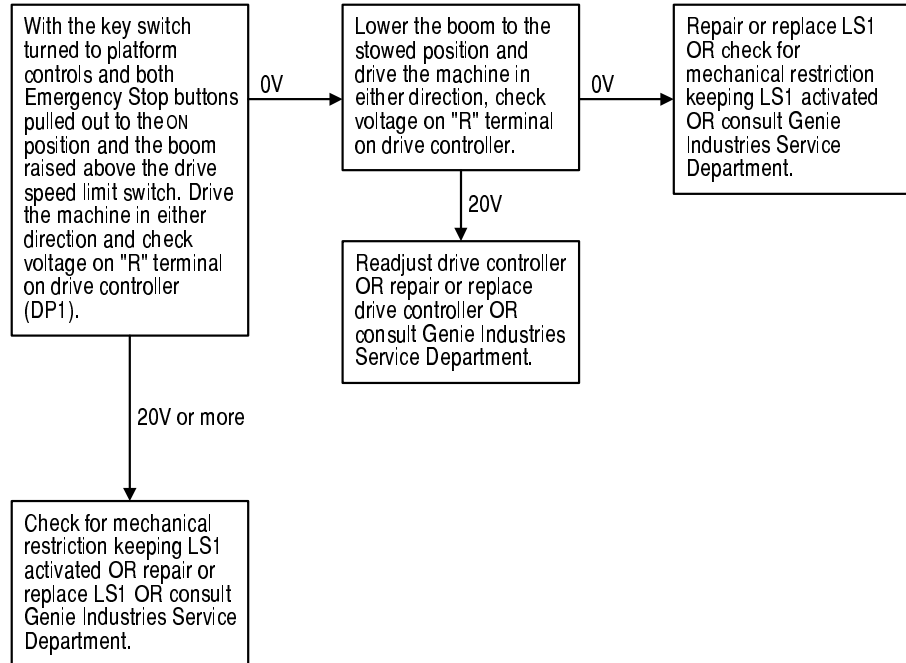

Chart 20

Brake Release Function Inoperative

Be sure all other functions operate normally.

Be sure the batteries are fully charged.

Be sure the battery packs are properly connected.

Be sure the circuit breakers and fuses are not tripped or blown.

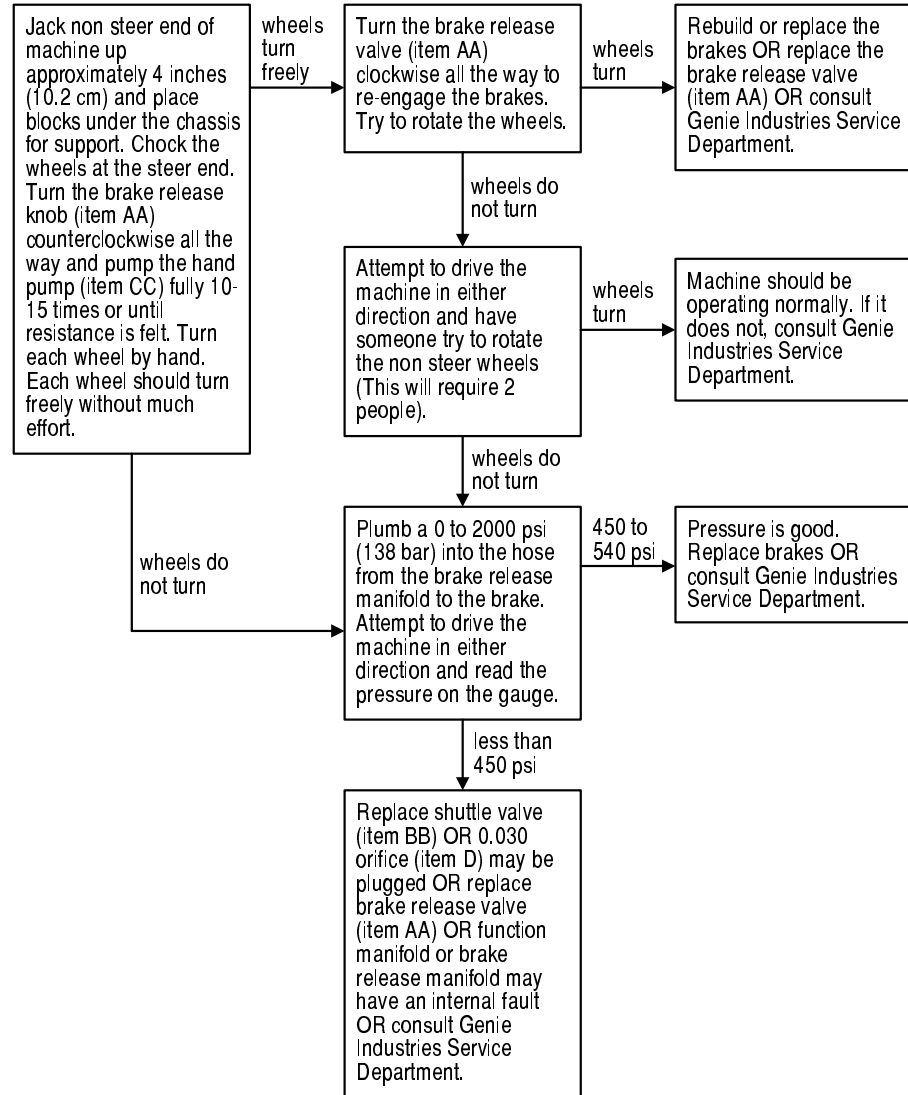

Schematics



Observe and Obey:

- ☑ Troubleshooting and repair procedures shall be completed by a person trained and qualified on the repair of this machine.
- ☑ Immediately tag and remove from service a damaged or malfunctioning machine.
- ☑ Repair any machine damage or malfunction before operating the machine.

Before Troubleshooting:

- ☑ Read, understand and obey the safety rules and operating instructions printed in the *Genie Z-25/8, Z-20/8 and Z-20/8N Operator's Manual*.
- ☑ Be sure that all necessary tools and test equipment are available and ready for use.

About This Section

There are two groups of schematics in this section. An illustration legend precedes each group of drawings.

Electrical Schematics

⚠WARNING Electrocutation hazard. Contact with electrically charged circuits could result in death or serious injury. Remove all rings, watches and other jewelry.

Hydraulic Schematics

⚠WARNING Bodily injury hazard. Spraying hydraulic oil can penetrate and burn skin. Loosen hydraulic connections very slowly to allow the oil pressure to dissipate gradually. Do not allow oil to squirt or spray.

General Repair Process

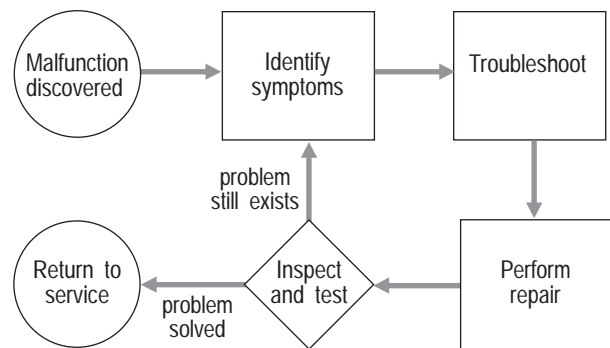

Electrical Components













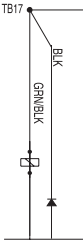



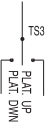

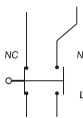
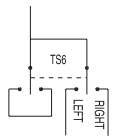

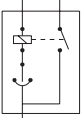
Item	Description	Genie Part Part Number	Manufacturer	Manufacturer Part Number	Qty
AP1, AP2	Anderson connector	13101	Anderson	6370-G1	2
BAT	Battery, 220AH, 6V DC	13006-S	Dyno Battery Co.	GC2B, dry	8
BCI	Battery charge indicator	23868	Curtis Instruments	13508010	1
CB1, CB2	Circuit breaker	375785	ETA	45-700-IG1-P10	2
CR2 through CR7	Relay - DPDT, 24V DC	36354	Omron	LY2-24DC	6
Diode	Diode, 7.5V 1watt	56877	Kent Component	IN4737A	1
Diode	Diode, 6 amp, 200 PIV	45782	Motorola	MOTMR752	34
DP1	Joystick controller	36867	OEM Controls	EMS4M10170	1
FB	Flashing beacon	20189	ECCO Electronic Controls ...	6400X	1
Fuse 1, 2	Fuse, 300 amp	13104	Buss	ANN-300	2
Fuse 3	Fuse, 100 amp	36355	Buss	ANN-100	1
FS1	Footswitch	13482	Linemaster Switch Corp.	632-S	1
H1	Alarm, Warble tone	45383	Floyd Bell Inc.	MW-09-530-Q	1
H2	Horn, 24V DC, 130 dB	45212	Sparton Engineered Prod. ...	7432-A24783-5	1
H3	Alarm, intermittent	18963	Floyd Bell Inc.	XB-09-630-Q	1
H4	Alarm, chime tone	45462	Floyd Bell Inc.	CH-09-525-Q	1
HM	Hourmeter	19506	ENM Corporation	T40A4508	1
KS1	Contact - Keyswitch, N.O. ...	45081	Telemecanique	ZB2-BE101	2

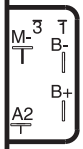
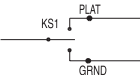
This list continues on the next page.

ELECTRICAL COMPONENTS

Item	Description	Genie Part Part Number	Manufacturer	Manufacturer Part Number	Qty
LS1	Contact - Limit switch, N.C.H.O.	19491	Telemecanique	XESP2051	1
Level sensor ..	Level sensor, 4.5° (ANSI & CSA)	44586	Power Comp. of Midwest	LS36	1
	3° (CE)	42439	Power Comp. of Midwest	LS40	1
MC1	Motor controller, 36V - 48V, 275 amp	36844	Curtis Instruments	1204-1158	1
P1, P2	Contact - N.C.	29732	Telemecanique	ZB2-BE102	4
P3	Contact - N.O.	45081	Telemecanique	ZB2-BE101	1
POT1	Potentiometer, 0-20kΩ	44993	BI Technologies	6187R20KL1.OST	1
PR1	Relay, 180 amp	19550	Curtis Instruments	13220544	1
PR2	Relay, 80 amp	19549	Curtis Instruments	13220149	1
R1	Resistor, 2Ω 2 watt	56701	Kent Component	FP-2-2K-1	1
TS1, TS7	Toggle switch, DPST 2 position momentary	13480	Microswitch Control Inc.	2NT1-8	2
TS2, TS11	Toggle switch - DPST 2 position maintained	27378	Microswitch Control Inc.	2NT1-3	2
TS3,4,5 and TS8,9,10	Toggle switch - DPDT 3 position momentary	16397	Microswitch Control Inc.	2NT1-7	6
TS6	Toggle switch - SPDT 3 position momentary	13037	Microswitch Control Inc.	1NT1-7	1

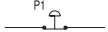
Electrical Symbols Legend

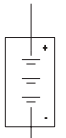
			
Wire color with cable number	Circuit breaker	Ground suppression circuit	Relay panel contactor
			
Terminal	Solenoid or relay coil	Horn	Toggle switch SPDT
			
Quick disconnect terminal	Light	Limit switch	Toggle switch DPDT
			
T-circuits connect at terminal	Tilt sensor	Limit switch normally open held closed	
			
T-circuits connect	Motor controller	Key switch	
			
Connection no terminal	Limit switch normally closed held open	Horn button normally open	
			
Circuits crossing no connection	Relay contact normally open	Emergency Stop button normally closed	
			
Diode			
			
6V Battery			

Abbreviation Legend

LABEL	DESCRIPTION
AP	Anderson Plug
BAT	Battery
BCI	Battery Charge Indicator
CB	Circuit Breaker
CR	Control Relay
DP	Drive Proportional Controller
FB	Flashing Beacon
FS	Foot Switch
H.....	Horn
HM.....	Hour Meter
KS	Keyswitch
LS	Limit Switch
MC.....	Motor Controller
P	Power Switch
POT	Potentiometer
PR	Power Relay
R.....	Resistor
TB.....	Terminal Base Location
TP	Terminal Platform Location
TS	Toggle Switch

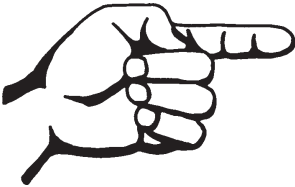

Electrical Schematic, Z-25/8 (before serial number 229), Z-20/8 (before serial number 125), Z-20/8N (before serial number 968)

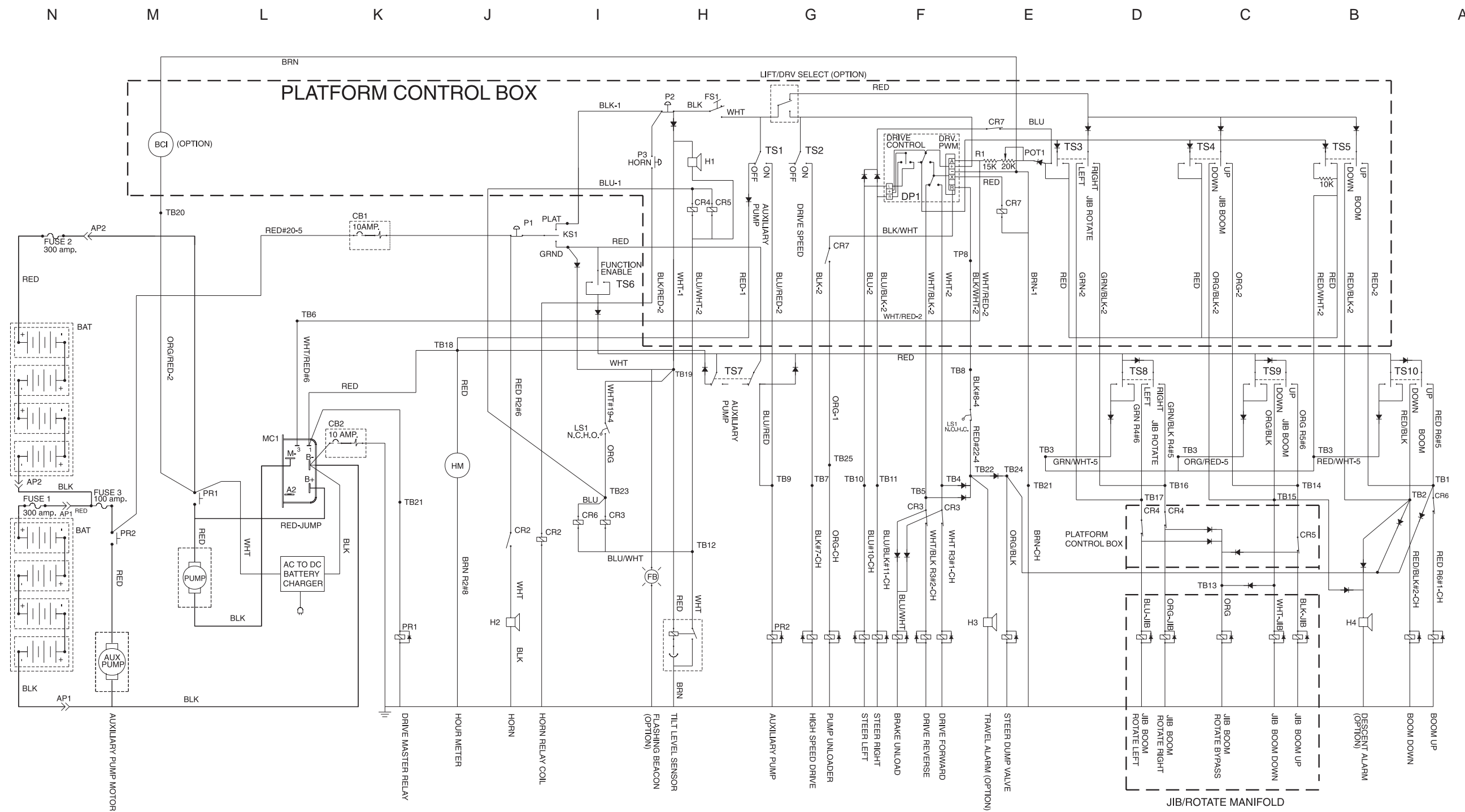

**Electrical Schematic, Z-25/8 (before serial number 229),
Z-20/8 (before serial number 125),
Z-20/8N (before serial number 968)**



Electrical Schematic, Z-25/8 (after serial number 228),
Z-20/8 (after serial number 124),
Z-20/8N (after serial number 967)

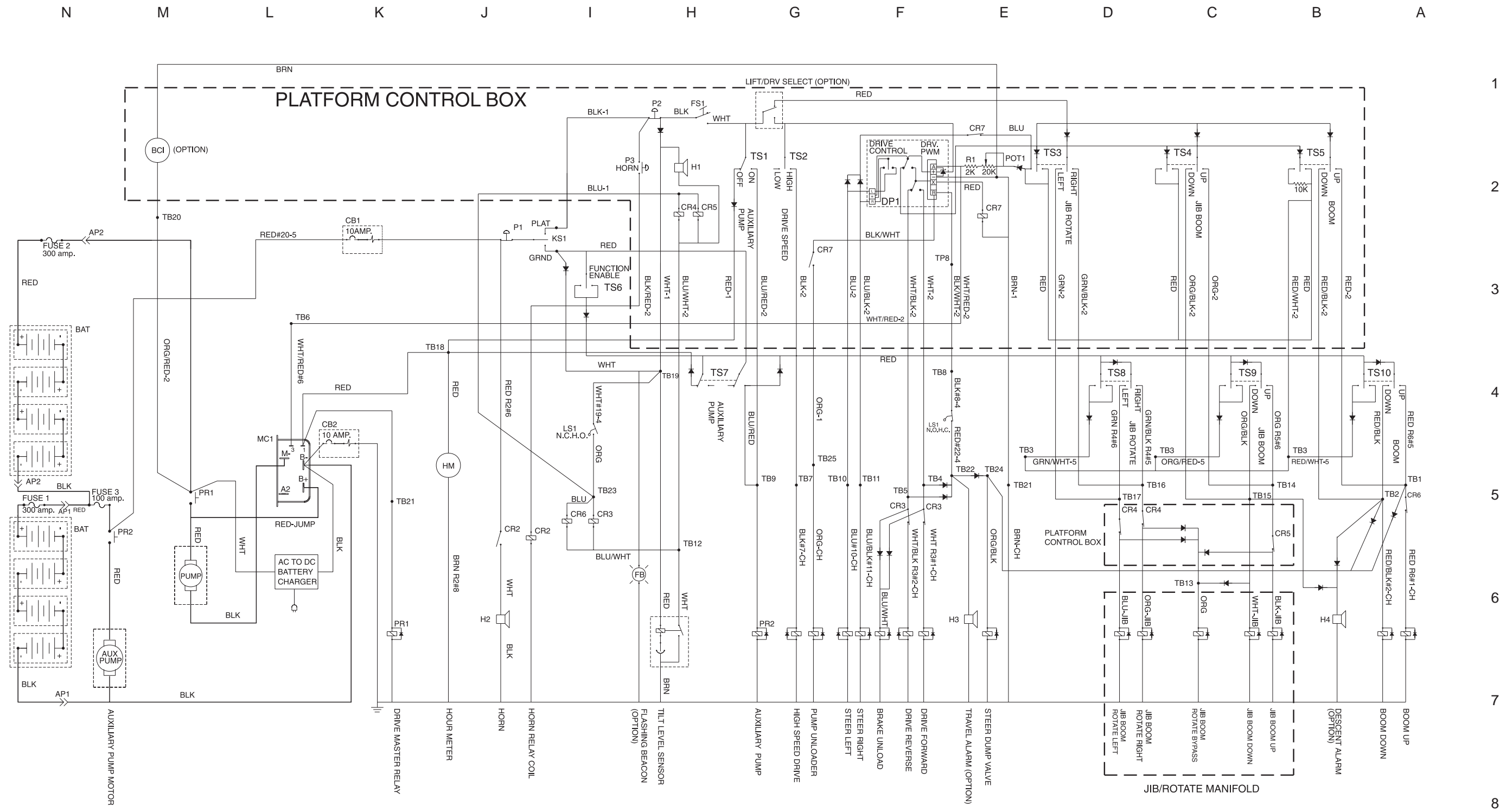

**Electrical Schematic, Z-25/8 (after serial number 228),
Z-20/8 (after serial number 124),
Z-20/8N (after serial number 967)**

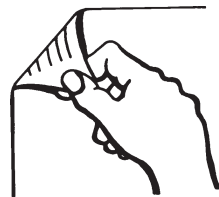

Ground Control Box Wiring Diagram

N M L K J I H G F E D C B A

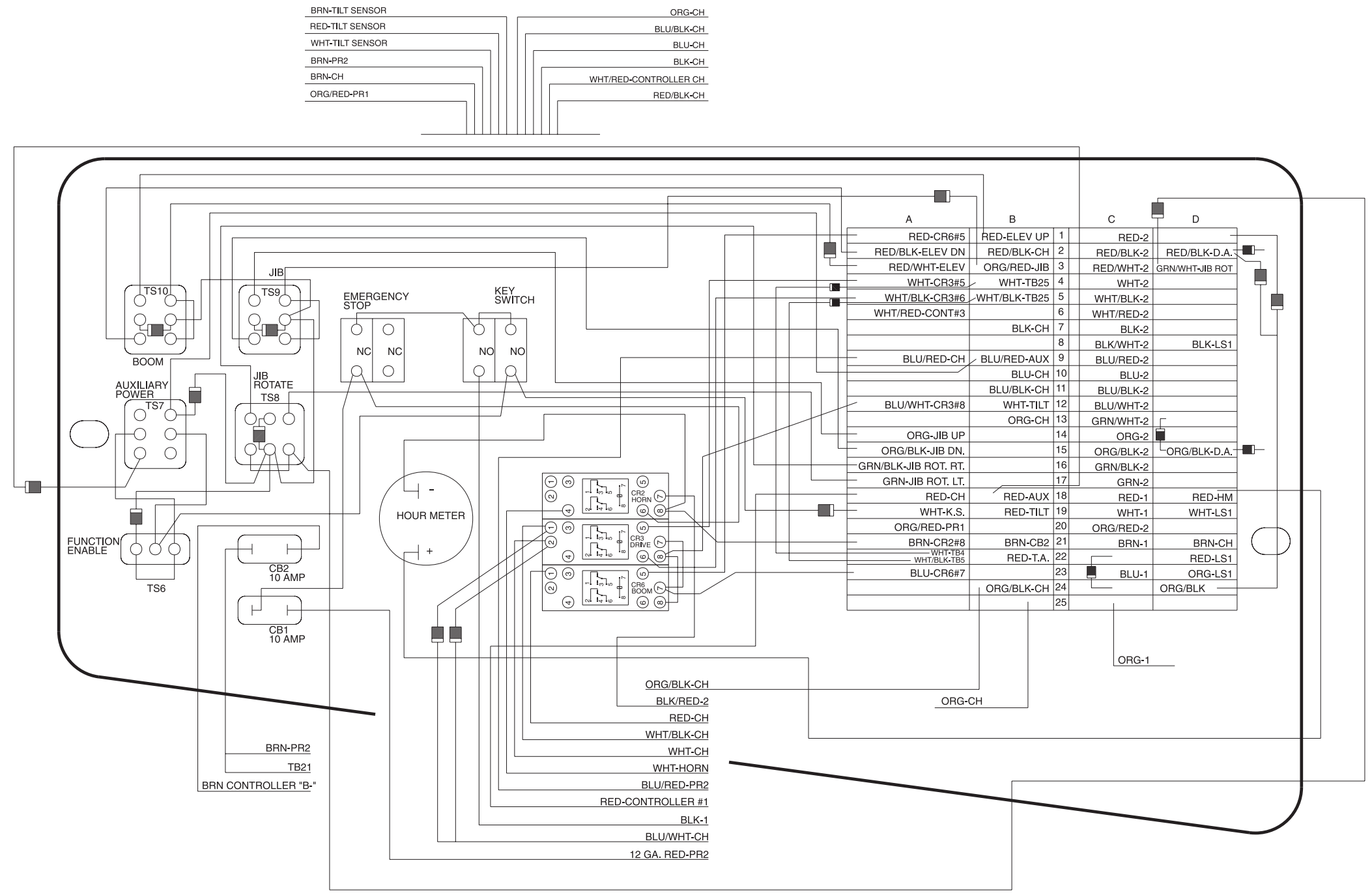

1
2
3
4
5
6
7
8

Ground Control Box Wiring Diagram



Platform Control Box Wiring Diagram, Z-25/8 (before-serial number 229), Z-20/8 (before serial number 125), Z-20/8N (before serial number 968)

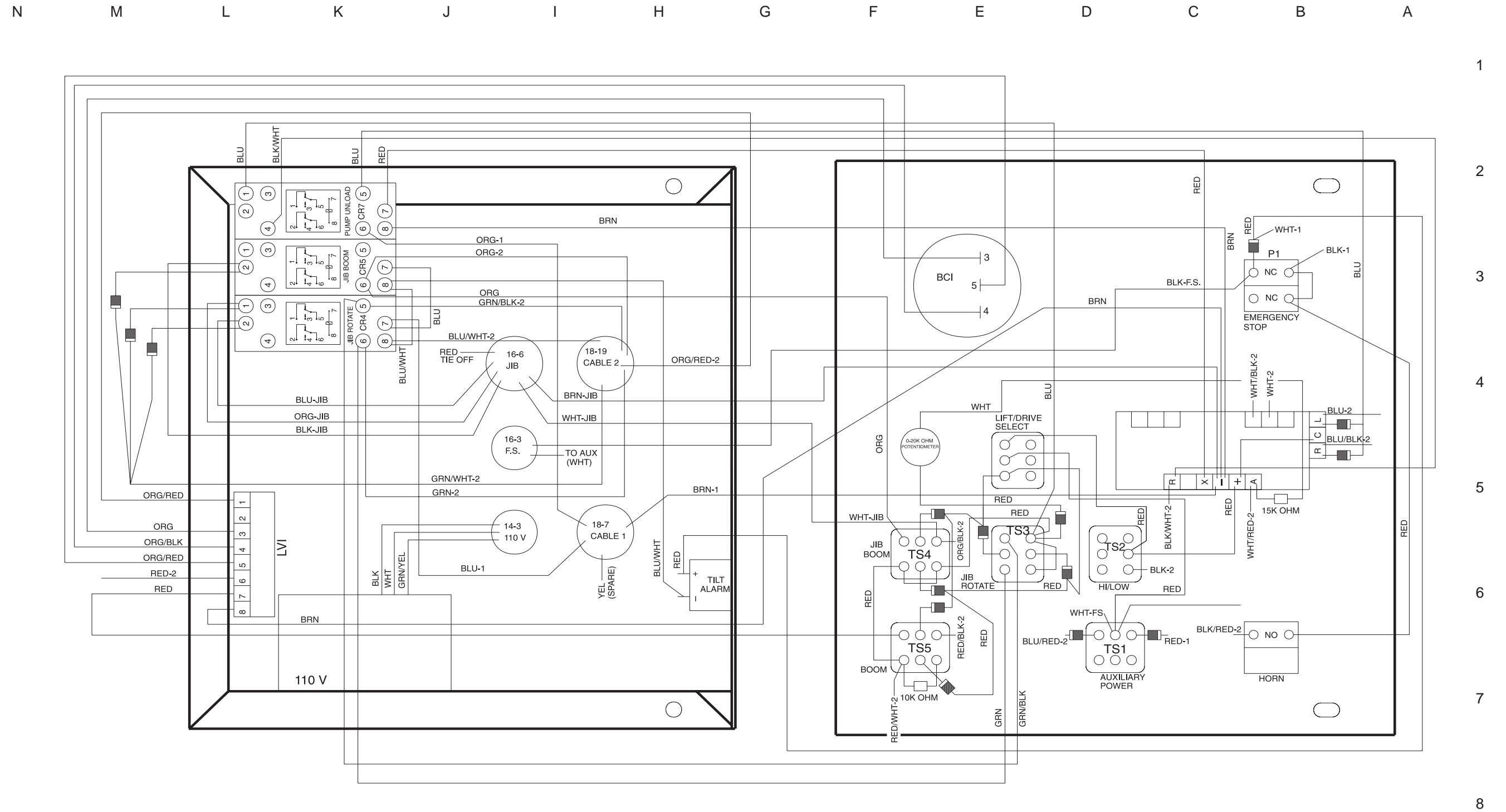

Platform Control Box Wiring Diagram, Z-25/8 (before-serial number 229), Z-20/8 (before serial number 125), Z-20/8N (before serial number 968)

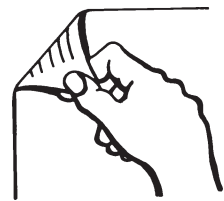

Platform Control Box Wiring Diagram, Z-25/8 (after-serial number 228), Z-20/8 (after serial number 124), Z-20/8N (after serial number 967)

N M L K J I H G F E D C B A

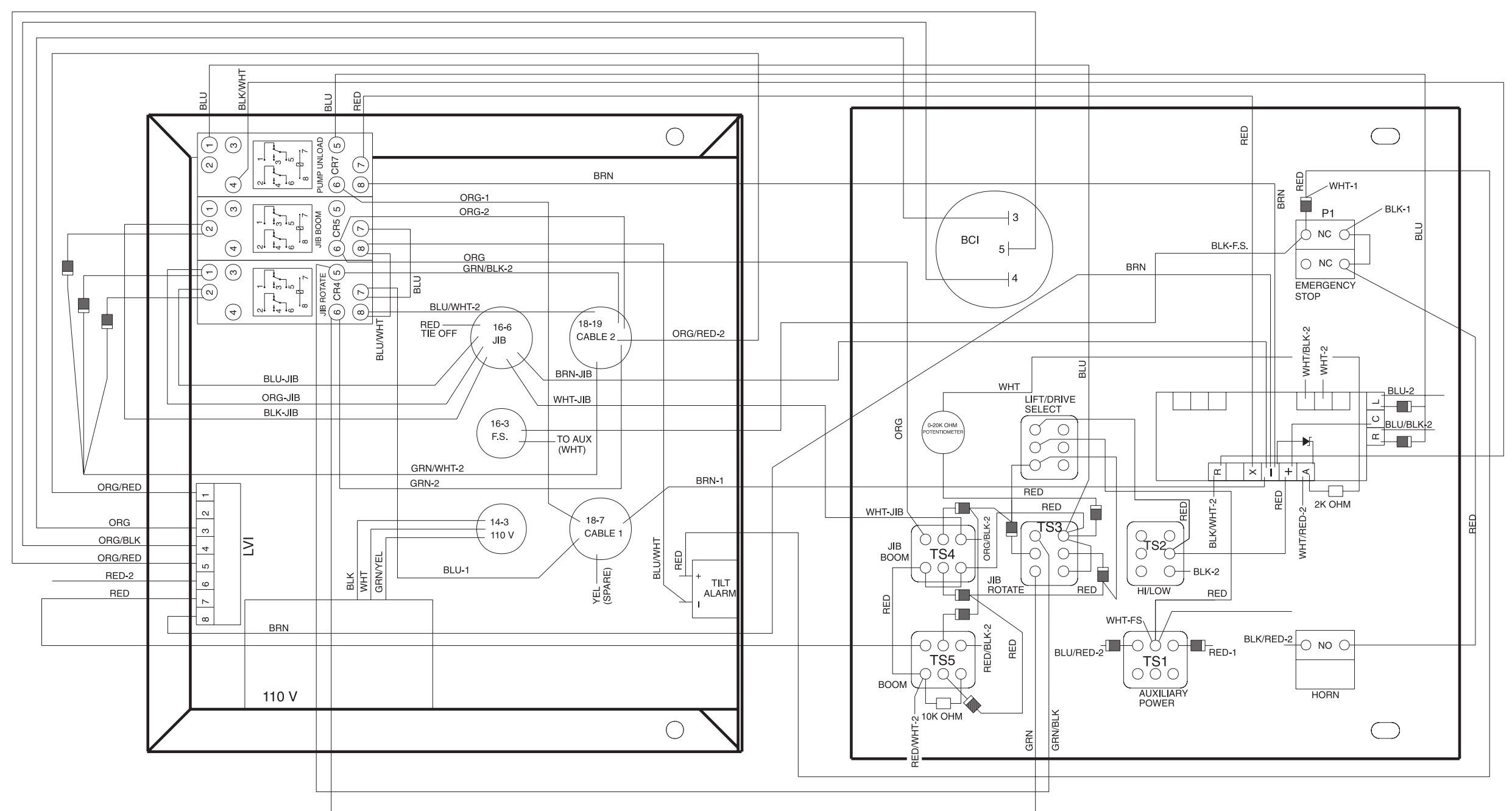

1
2
3
4
5
6
7
8

Platform Control Box Wiring Diagram, Z-25/8 (after-serial number 228), Z-20/8 (before serial number 124), Z-20/8N (before serial number 967)



Power Cable Diagram

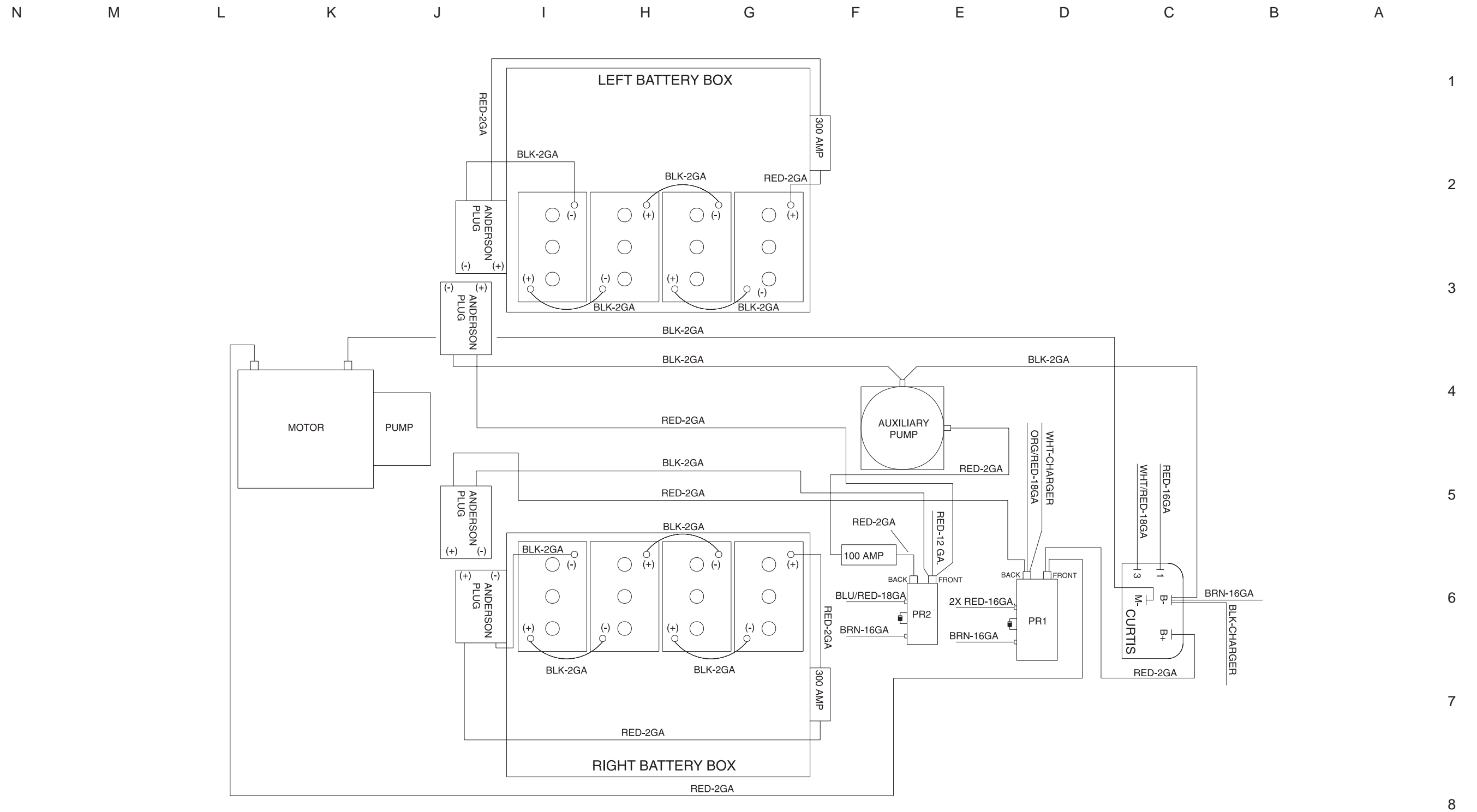

Power Cable Diagram

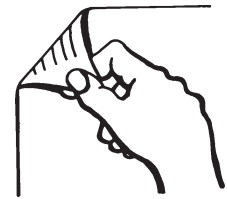

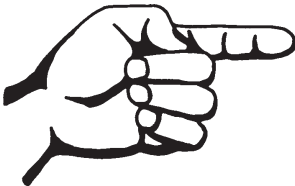

Hydraulic Symbols Legend

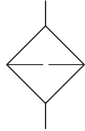

Filter

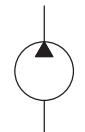

Fixed displacement pump

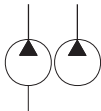

Two stage, fixed displacement pump



Bi-directional motor



Pump prime mover motor



Double acting cylinder



Orifice with size



Check valve

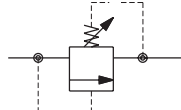

Relief valve

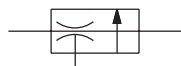

Priority flow divider

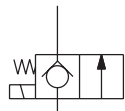

Solenoid operated dump valve

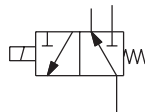

Solenoid operated 2 pos., 3 way, directional valve

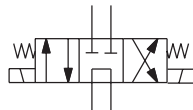

Solenoid operated 3 pos., 4 way, directional valve

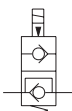

Solenoid operated 2 pos., 2 way, N.O. Poppet valve

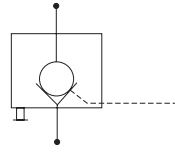

Check valve, pilot to open



Shuttle valve

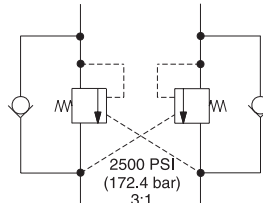

Counterbalance valve

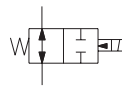

Solenoid operated 2 pos., 2 way, directional valve

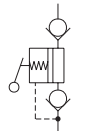

Brake release hand pump



Brake

Hydraulic Schematic, Z-25/8 (before serial number 229),
Z-20/8 (before serial number 125),
Z-20/8N (before serial number 968)

N M L K J I H G F E D C B A

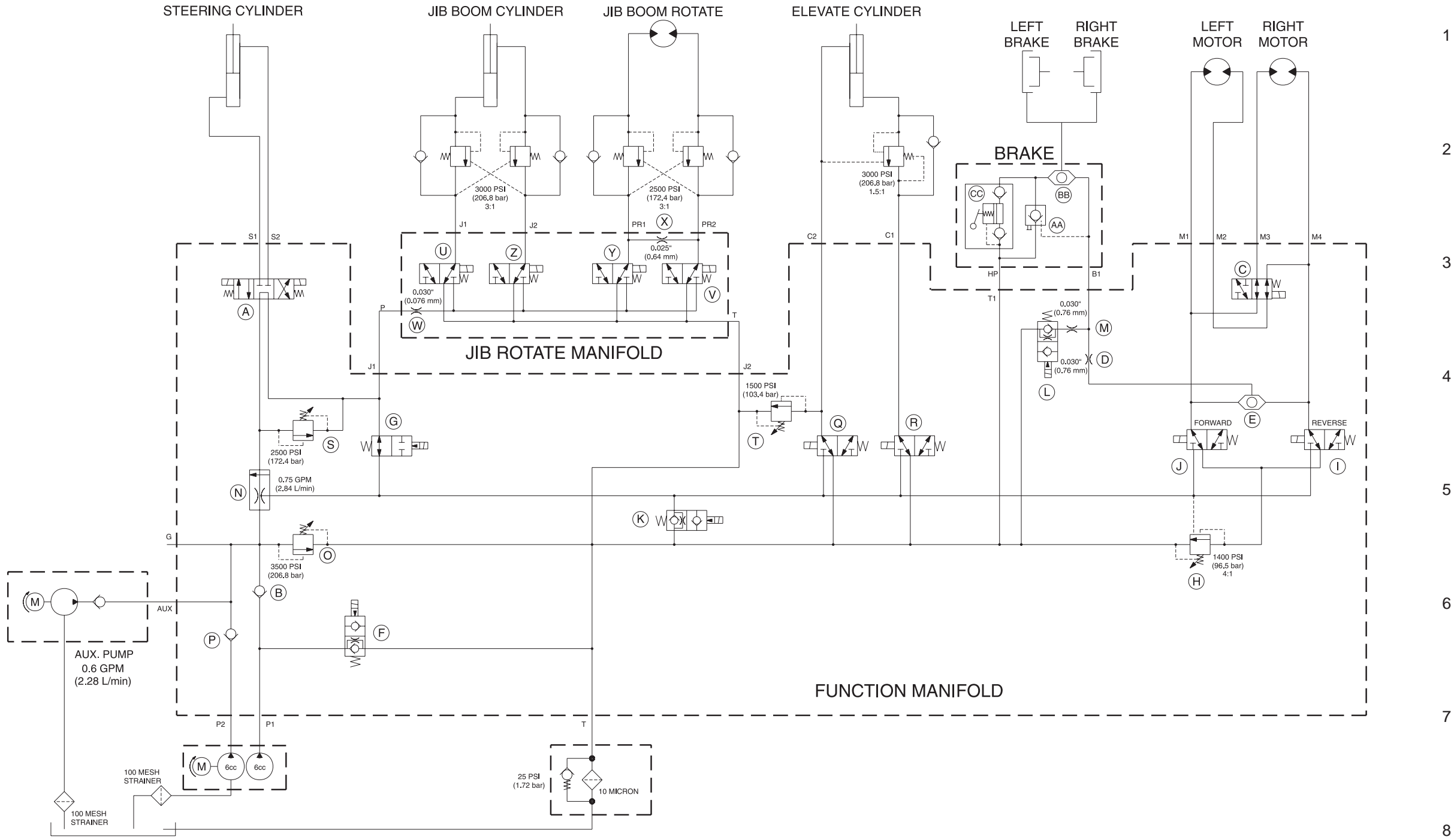

**Hydraulic Schematic, Z-25/8 (before serial number 229),
Z-20/8 (before serial number 125),
Z-20/8N (before serial number 968)**

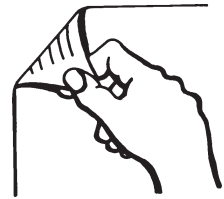

**Hydraulic Schematic, Z-25/8 (after serial number 228),
Z-20/8 (after serial number 124),
Z-20/8N (after serial number 967)**

N M L K J I H G F E D C B A

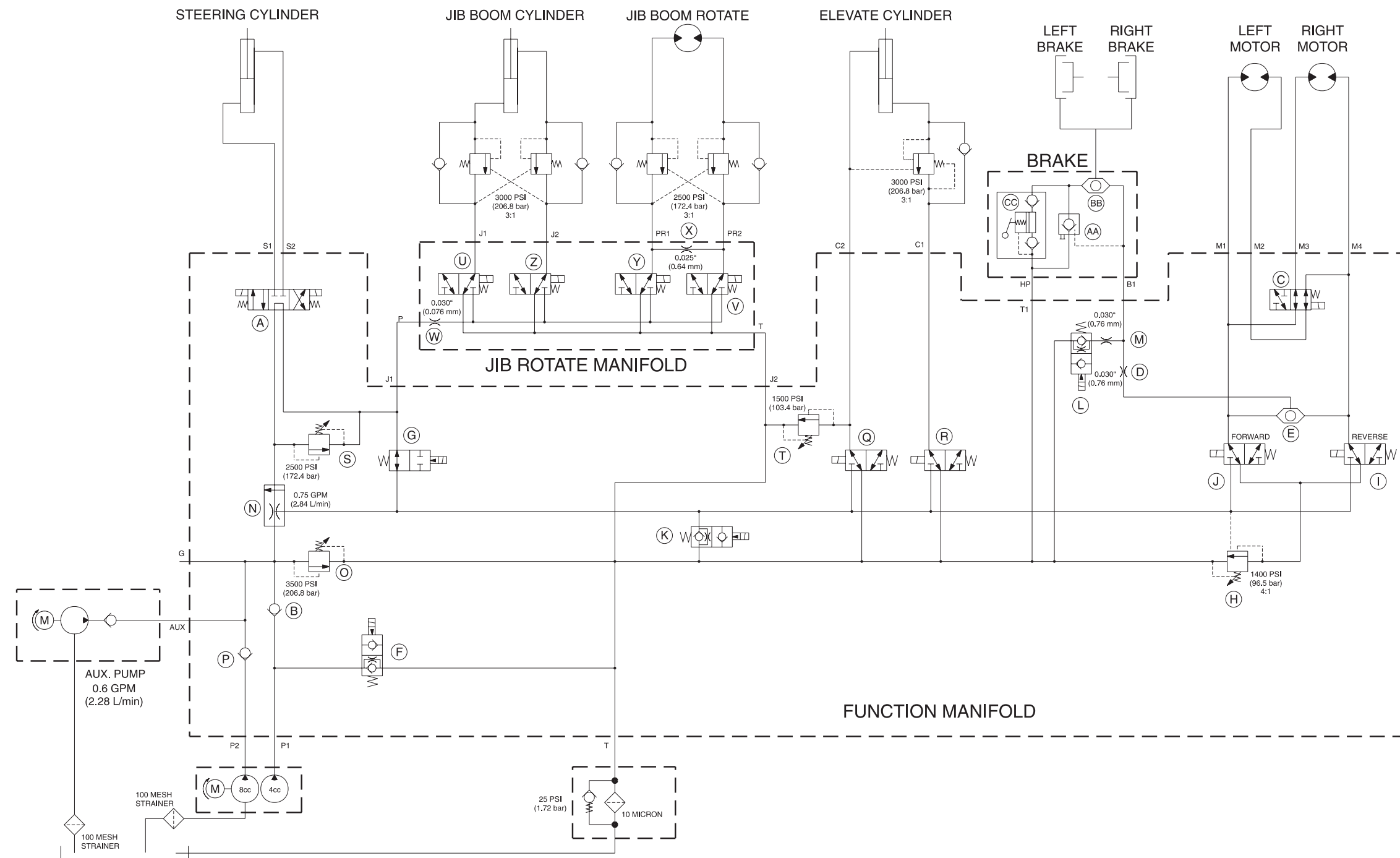

1
2
3
4
5
6
7
8

**Hydraulic Schematic, Z-25/8 (after serial number 228),
Z-20/8 (after serial number 124),
Z-20/8N (after serial number 967)**

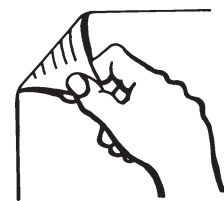

Repair Procedures



Observe and Obey:

- ☑ Repair procedures shall be completed by a person trained and qualified on the repair of this machine.
- ☑ Immediately tag and remove from service a damaged or malfunctioning machine.
- ☑ Repair any machine damage or malfunction before operating the machine.

Before Repairs Start:

- ☑ Read, understand and obey the safety rules and operating instructions in the *Genie Z-20/8N & Genie Z-20/8 & Genie Z-25/8 Operator's Manual*.
- ☑ Be sure that all necessary tools and parts are available and ready for use.
- ☑ Read each procedure completely and adhere to the instructions. Attempting shortcuts may produce hazardous conditions.
- ☑ Unless otherwise specified, perform each repair procedure with the machine in the following configuration:
 - Machine parked on a flat, level surface
 - Boom in the stowed position
 - Key switch in the OFF position with the key removed
 - Battery packs disconnected
 - Wheels chocked

About This Section

Most of the procedures in this section should only be performed by a trained service professional in a suitably equipped workshop. Select the appropriate repair procedure after troubleshooting the problem.

Perform disassembly procedures to the point where repairs can be completed. Then to re-assemble, perform the disassembly steps in reverse order.

Symbols Legend



Safety alert symbol—used to alert personnel to potential personal injury hazards. Obey all safety messages that follow this symbol to avoid possible injury or death.

▲ DANGER

Red—used to indicate the presence of an imminently hazardous situation which, if not avoided, will result in death or serious injury.

▲ WARNING

Orange—used to indicate the presence of a potentially hazardous situation which, if not avoided, could result in death or serious injury.

▲ CAUTION

Yellow with safety alert symbol—used to indicate the presence of a potentially hazardous situation which, if not avoided, may cause minor or moderate injury.

CAUTION

Yellow without safety alert symbol—used to indicate the presence of a potentially hazardous situation which, if not avoided, may result in property damage.

NOTICE

Indicates special operation or maintenance information.

- ⊙ Indicates that a specific result is expected after performing a series of steps.

Platform Controls

1-1 Joystick Controller

Maintaining the joystick controller at the proper setting is essential to safe machine operation. The joystick controller should operate smoothly and provide proportional speed control through its entire range of motion.

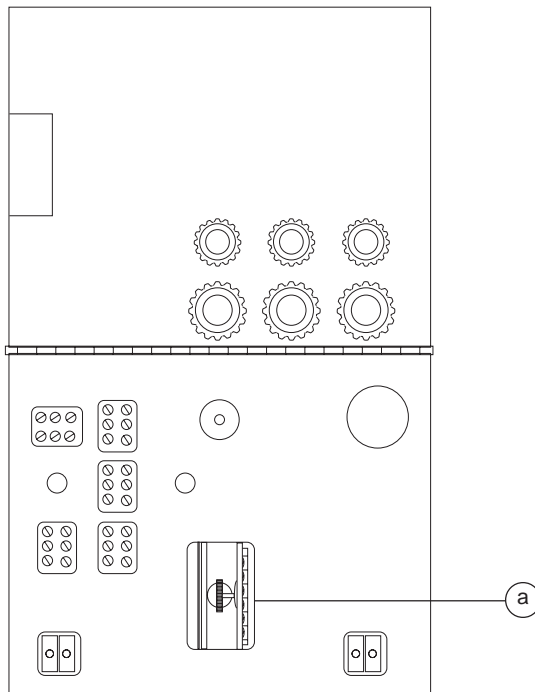

a joystick controller

Joystick Controller Adjustments

▲WARNING Electrocution hazard. Contact with electrically charged circuits could result in death or serious injury. Remove all rings, watches and other jewelry.

NOTICE Do not adjust the controller unless the static battery supply voltage is above 24V DC.

NOTICE Individual trim potentiometers (trimpots) are used to adjust various output signals from the drive controller. The trimpots will be identified as the following:

- Max out trim potentiometer (max out trimpot)
 - High range trim potentiometer (max out trimpot)
 - Lo range trim potentiometer (lo range trimpot)
 - Duel range trim potentiometer (lo range trimpot)
 - Threshold trim potentiometer (threshold trimpot)
 - Ramp rate trim potentiometer (ramp rate trimpot)
- 1 Block the non-steering wheels, and then center a lifting jack under the drive chassis between the steer tires.
 - 2 Raise the drive chassis approximately 2 inches (5 cm) off the ground and place blocks under the chassis for support.

PLATFORM CONTROLS

- 3 Open the platform control box and locate the printed circuit board on the drive controller.

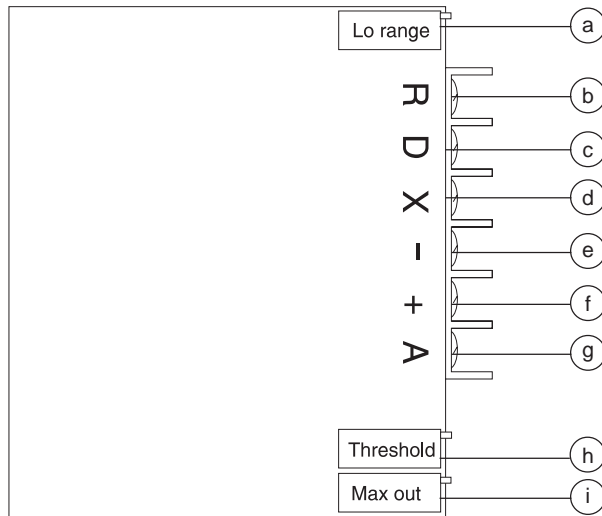

- a lo range trimpot
- b terminal "R", activates max out range
- c terminal "D", drive output
- d terminal "X" (not used)
- e terminal "-", ground
- f terminal "+", positive
- g terminal "A"
- h threshold trimpot
- i max out trimpot

- 4 Connect the red (+) lead from a volt meter to the "A" terminal on the drive controller printed circuit board. Connect the black (-) lead to ground.
- 5 Turn the key switch to platform control and pull out the Emergency Stop button to the ON position at both the ground and platform controls.

- 6 Move the lift/drive toggle switch to the drive position (if equipped).

- 7 Set the threshold on the circuit board: Press down the foot switch, then slowly move the control handle off center until you hear the pump motor turn on. Adjust the threshold trimpot (item h) on the circuit board to 1.2V DC. Turn the threshold trimpot adjustment screw clockwise to increase the voltage or counterclockwise to decrease the voltage.

- 8 Set the high range on the circuit board:

Z-20/8N Models: Press down the foot switch, then slowly move the control handle all the way in the FORWARD position. Adjust the max out trimpot (item i) on the circuit board to 4.7 to 4.8V DC. Turn the max out trimpot adjustment screw clockwise to increase the voltage or counterclockwise to decrease the voltage.

Z-20/8 & Z-25/8 Models: Press down the foot switch, then slowly move the control handle all the way in the FORWARD position. Adjust the max out trimpot (item i) on the circuit board to 4.4 to 4.5V DC. Turn the max out trimpot adjustment screw clockwise to increase the voltage or counterclockwise to decrease the voltage.

- 9 Release the foot switch.
- 10 Move the lift/drive toggle switch to the lift position (if equipped).
- 11 Raise the boom approximately 5 feet (1.5 m).

PLATFORM CONTROLS

- 12 Move the lift/drive toggle switch to the drive position (if equipped).
- 13 Set the lo range on the circuit board:
 - Z-20/8N Models:** Press down the foot switch, then move the control handle all the way to the FORWARD position. Adjust the lo range trimpot (item a) on the circuit board to 2.02 to 2.12V DC. Turn the lo range trimpot adjustment screw clockwise to increase the voltage or counterclockwise to decrease the voltage.
 - Z-20/8 & Z-25/8 Models:** Press down the foot switch, then move the control handle all the way to the FORWARD position. Adjust the lo range trimpot (item a) on the circuit board to 1.95 to 2.05V DC. Turn the lo range trimpot adjustment screw clockwise to increase the voltage or counterclockwise to decrease the voltage.
- 14 Move the lift/drive toggle switch to the lift position (if equipped).
- 15 Lower the boom to the stowed position and remove the support blocks.
- 16 At the platform controls raise the boom approximately 5 feet (1.5 m).
- 17 Move the lift/drive toggle switch to the drive position (if equipped).
- 18 Create start and finish lines by marking two lines on the ground 40 feet (12.2 m) apart. Choose a reference point on the machine as a visual reference for use when crossing the start and finish lines.
- 19 Bring the machine to top drive speed before reaching the start line. Begin timing when your reference point on the machine crosses the start line.
- 20 Continue at full speed and note the time when the reference point crosses the finish line.
- 21 Adjust lo range trimpot (item a) on the drive circuit board to achieve a 40 second drive speed time. Turn the lo range trimpot adjustment screw clockwise to decrease the time or counterclockwise to increase the time.
- 22 Move the lift/drive toggle switch to the lift position (if equipped).
- 23 Lower the boom to the stowed position.
- 24 Move the lift/drive toggle switch to the drive position (if equipped).
- 25 Bring the machine to top drive speed before reaching the start line. Begin timing when your reference point on the machine crosses the start line.
- 26 Continue at full speed and note the time when the reference point crosses the finish line.
 - Z-20/8N Models:** Adjust max out trimpot (item i) on the circuit board to achieve the specified drive speed time. Turn the max out adjustment screw trimpot clockwise to decrease the time or counterclockwise to increase the time.
 - Z-20/8 & Z-25/8 Models:** Adjust max out trimpot (item i) on the circuit board to achieve the specified drive speed time. Turn the max out adjustment screw trimpot clockwise to decrease the time or counterclockwise to increase the time.

PLATFORM CONTROLS

Drive controller specifications

Drive

Threshold, all models 1.2V DC

Max out

(when joystick is in full forward position)

Z-20/8N models 4.7 to 4.8V DC

Z-20/8 and Z-25/8 models 4.4 to 4.5V DC

Lo range

(when joystick is in full forward position)

Z-20/8N models 2.02 to 2.12V DC

Z-20/8 and Z-25/8 models 1.95 to 2.05V DC

Drive speeds

Z-20/8N models

Stowed position, max out	2.6 mph	4.2 km/h
	40 ft/10.5 sec	12.2 m/10.5 sec

Lo range	1.3 mph	2.1 km/h
	40 ft/20.9 sec	12.2 m/20.9 sec

Boom raised	0.6 mph	1 km/h
	40 ft/40 sec	40 ft/40 sec

Z-20/8 & Z-25/8 models

Stowed position, max out	2.7 mph	4.3 km/h
	40 ft/10.1 sec	12.2 m/10.1 sec

Lo range	1.4mph	2.3 km/h
	40 ft/19.5 sec	12.2 m/19.5 sec

Boom raised	0.6 mph	1 km/h
	40 ft/40 sec	40 ft/40 sec

**1-2
Foot Switch**

How to Test the Foot Switch

- 1 Turn the key switch to the OFF position and separate the wiring quick disconnect plug from the platform toe board.
- 2 Do not press down the foot switch. Connect the leads from an ohmmeter or continuity tester to the wire combination listed below and check for continuity.

Test	Desired result
red to black	continuity (zero Ω)
red to white	no continuity (infinite Ω)
black to white	no continuity (infinite Ω)

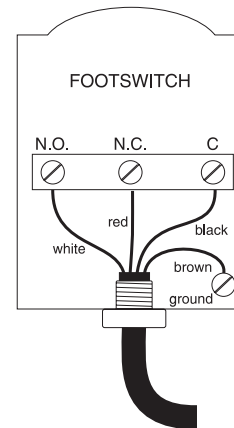

PLATFORM CONTROLS

- 3 Press down the foot switch. Connect the leads from an ohmmeter or continuity tester to the wire combination listed below and check for continuity.

Test	Desired result
red to black	no continuity (infinite Ω)
red to white	no continuity (infinite Ω)
black to white	continuity (zero Ω)

1-3 Toggle Switches

Toggle switches used for single function switching are single pole double throw (SPDT) switches. Dual function switching requires a double pole double throw (DPDT) switch.

How to Test a Toggle Switch

NOTICE Continuity is the equivalent of 0 to 3 ohms. A simple continuity tester may not accurately test the switch.

This procedure covers fundamental switch testing and does not specifically apply to all varieties of toggle switches.

- 1 Turn the key switch to the OFF position. Tag and disconnect all wiring from the toggle switch to be tested.
- 2 Connect the leads of an ohmmeter to the switch terminals in the following combinations listed below to check for continuity.

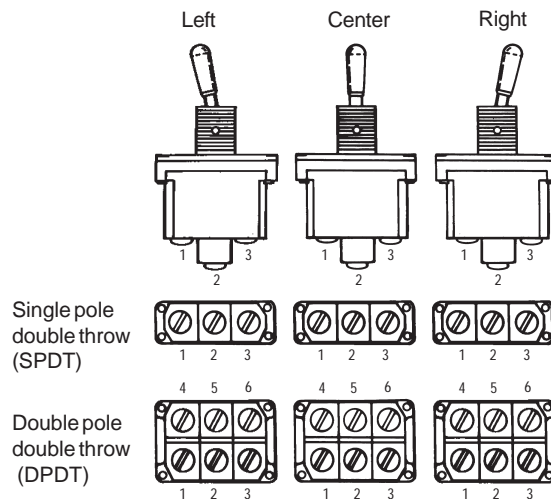

PLATFORM CONTROLS

Test	Desired result
Left position	
terminal 1 to 2, 3, 4, 5 & 6	no continuity (infinite Ω)
terminal 2 to 3	continuity (zero Ω)
terminal 2 to 4, 5 & 6	no continuity (infinite Ω)
terminal 3 to 4, 5 & 6	no continuity (infinite Ω)
terminal 4 to 5 & 6	no continuity (infinite Ω)
terminal 5 to 6	continuity (zero Ω)
Center position	There are no terminal combinations that will produce continuity (infinite Ω)
Right position	
terminal 1 to 2	continuity (zero Ω)
terminal 1 to 3, 4, 5 & 6	no continuity (infinite Ω)
terminal 2 to 3, 4, 5 & 6	no continuity (infinite Ω)
terminal 3 to 4, 5 & 6	no continuity (infinite Ω)
terminal 4 to 5	continuity (zero Ω)
terminal 4 to 6	no continuity (infinite Ω)
terminal 5 to 6	no continuity (infinite Ω)

1-4 Control Relays

How to Test a Double Pole Double Throw Relay

Relays used for dual function switching are double pole double throw (DPDT) relays.

WARNING Electrocutation hazard. Contact with electrically charged circuits could cause death or serious injury. Remove all rings, watches and other jewelry.

This procedure covers fundamental relay testing and does not specifically apply to all varieties of relays.

- 1 Turn the key switch to the OFF position and remove the key.
- 2 Label and then disconnect all the wiring from the relay to be tested.
- 3 Connect the leads from an ohmmeter to each terminal combination and check for continuity. Terminals 7 and 8 represent the coil and should not be tested in any other combination.

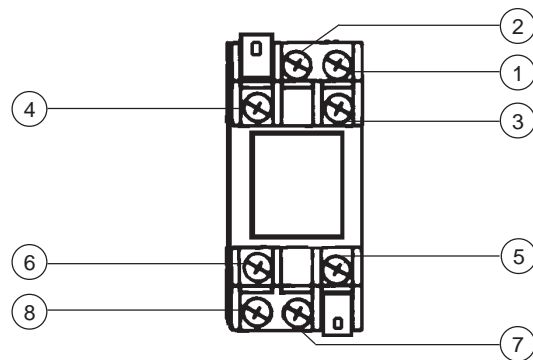

Bubble number represents the terminal number

PLATFORM CONTROLS

Test	Desired result
terminal 7 to 8	640 to 650Ω
terminal 1 to 2, 3, 4 & 6	no continuity (infinite Ω)
terminal 2 to 3, 4 & 5	no continuity (infinite Ω)
terminal 3 to 6	no continuity (infinite Ω)
terminal 2 to 6	continuity (zero Ω)
terminal 1 to 5	continuity (zero Ω)

4 Connect 24V DC to terminal 8 and a ground wire to terminal 7, then test the following terminal combinations.

Test	Desired result
terminal 1 to 2, 4, 5 & 6	no continuity (infinite Ω)
terminal 2 to 3, 5 & 6	no continuity (infinite Ω)
terminal 1 to 3	continuity (zero Ω)
terminal 2 to 4	continuity (zero Ω)

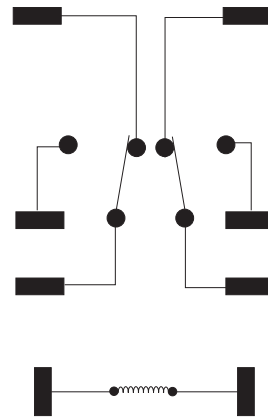

Relay Schematic

Platform Components

2-1 Platform

How to Remove the Platform

- 1 Separate the foot switch wiring quick disconnect plug from the platform toeboard.
- 2 Open the platform control box.

WARNING Electrocutation hazard. Contact with electrically charged circuits could result in death or serious injury. Remove all rings, watches and other jewelry.

- 3 Remove the platform control box mounting fasteners, lower the control box and lay it off to the side.

CAUTION Component damage hazard. Cables can be damaged if they are kinked or pinched.

NOTICE If your machine is equipped with an air line to platform option, the air line must be disconnected from the platform before removal.

- 4 Raise the jib boom slightly and place sawhorses under the platform. Lower the jib boom just until the platform is resting on the sawhorses.

NOTICE Do not rest the entire weight of the boom on the sawhorses.

- 5 Remove the platform mounting fasteners and remove the platform.

NOTICE Do not overtighten the platform mounting fasteners during installation.

Jib Boom Components

3-1 Jib Boom

How to Remove the Jib Boom

NOTICE Perform this procedure with the boom in the stowed position.

NOTICE When removing a hose assembly or fitting, the O-ring on the fitting and/or hose end must be replaced and then torqued to specification during installation. Refer to Section Two, *Hydraulic Hose and Fitting Torque Specifications*.

- 1 Remove the platform. See 2-1, *How to Remove the Platform*.
- 2 Raise the jib boom slightly and place blocks under the platform mounting weldment. Then lower the jib boom just until the platform mounting weldment is resting on the blocks.

NOTICE Do not rest the entire weight of the jib boom on the blocks.

- 3 Remove the cable cover mounting fasteners from the ground controls side of the jib boom.
- 4 Remove the jib boom pivot pin retaining fasteners that attach the clamps at the jib boom rotator. Do not remove the pins.

- 5 Remove the retaining fasteners from the two hose clamps on the jib rotator. Remove the clamps.

- 6 **Z-25/8 before serial number 212**
Z-20/8 before serial number 122
Z-20/8N before serial number 896: Remove the jib manifold cover mounting fasteners. Remove the cover.

- 7 Tag and disconnect the wiring from the jib boom manifold.

- 8 Tie the wiring and cables out of the way.

CAUTION Component damage hazard. Cables and wiring can be damaged if they are kinked or pinched.

- 9 Tag, disconnect and plug the hydraulic hoses from the jib boom lift cylinder. Cap the fittings on the cylinder.

AWARNING Bodily injury hazard. Spraying hydraulic oil can penetrate and burn skin. Loosen hydraulic connections very slowly to allow the oil pressure to dissipate gradually. Do not allow oil to squirt or spray.

- 10 Support both jib boom leveling arms with a lifting device.

- 11 Remove the pin retaining fasteners from both ends of the jib boom leveling arm pivot pin at the platform mounting weldment.

JIB BOOM COMPONENTS

- 12 Use a soft metal drift to remove the pin.
Carefully lower the jib boom leveling arms to the ground.

▲WARNING Crushing hazard. The jib boom leveling arms will fall when the pin is removed if they are not properly supported.

- 13 Remove the pin retaining fasteners from the barrel-end pivot pin of the jib boom lift cylinder. Do not remove the pin.
- 14 Support the barrel end of the jib boom cylinder with a lifting device.
- 15 Support the jib boom with an overhead crane.
- 16 Remove the jib boom cylinder barrel-end pivot pin using a soft metal drift.
- 17 Lower the cylinder and let it hang down.
Remove the platform mounting weldment.
- 18 Tag, disconnect and plug the hydraulic hoses from the jib boom manifold. Cap the fittings on the manifold.

▲WARNING Bodily injury hazard. Spraying hydraulic oil can penetrate and burn skin. Loosen hydraulic connections very slowly to allow the oil pressure to dissipate gradually. Do not allow oil to squirt or spray.

- 19 Tag, disconnect and plug the hydraulic hoses from the jib manifold. Cap the fittings on the manifold.

- 20 Remove the mounting fasteners from the jib boom manifold and lay the manifold off to the side.

- 21 Secure all hoses and cables out of the way.

▲CAUTION Component damage hazard. Hoses and cables can be damaged if they are kinked or pinched.

- 22 Attach a strap from an overhead crane to the cross tube on the jib boom at the jib boom mounting weldment end.
- 23 Use a soft metal drift to remove the jib boom pivot pin from the jib boom mounting weldment. Remove the jib boom from the machine.

▲WARNING Crushing hazard. The jib boom will fall when the pin is removed if it is not properly supported.

- 24 Remove the pin retaining fasteners from the jib boom lift cylinder rod-end pivot pin. Do not remove the pin.
- 25 Remove both of the jib boom leveling arms from the jib cylinder rod-end pivot pin and lay them off to the side.
- 26 Attach a lifting strap from an overhead crane to the lug on the rod end of the jib boom lift cylinder.

JIB BOOM COMPONENTS

27 Use a soft metal drift to remove the jib boom lift cylinder rod-end pivot pin, then remove the jib boom lift cylinder from the machine.

⚠WARNING Crushing hazard. The jib boom lift cylinder will fall when the pin is removed if it is not properly supported.

28 Attach a strap from an overhead crane to the jib boom mounting weldment at the jib rotator.

29 Remove the jib boom mounting weldment fasteners and remove the jib boom mounting weldment from the machine.

⚠WARNING Crushing hazard. The jib boom mounting weldment will fall when the pin is removed if it is not properly supported.

3-2 Jib Boom Cylinder

How to Remove the Jib Boom Cylinder

NOTICE When removing a hose assembly or fitting, the O-ring on the fitting and/or hose end must be replaced and then torqued to specification during installation. Refer to Section Two, *Hydraulic Hose and Fitting Torque Specifications*.

- 1 Raise the jib boom and place sawhorses under the platform.
- 2 Lower the platform onto the sawhorses just until the platform rests onto the sawhorses.

NOTICE Do not rest the entire weight of the boom on the sawhorses.

- 3 Tag, disconnect and plug the hydraulic hoses from the jib boom lift cylinder. Cap the fittings on the cylinder.

⚠WARNING Bodily injury hazard. Spraying hydraulic oil can penetrate and burn skin. Loosen hydraulic connections very slowly to allow the oil pressure to dissipate gradually. Do not allow oil to squirt or spray.

- 4 Remove the pin retainers from the jib boom lift cylinder rod-end pivot pin. Do not remove the pin.

JIB BOOM COMPONENTS

- 5 Use a soft metal drift to tap the rod-end pivot pin half way out. Then lower one leveling arm to the ground. Tap the pin the opposite direction and lower the other leveling arm. Do not remove the pin.
- 6 Support the barrel end of the jib boom lift cylinder with an overhead crane.
- 7 Support the jib boom with a lifting device at the platform end.
- 8 Remove the pin retaining fasteners from the jib boom lift cylinder barrel-end pivot pin. Use a soft metal drift to remove the barrel-end pivot pin.

AWARNING Crushing hazard. The jib boom could fall when pin is removed if it is not properly supported.

- 9 Lower the barrel end of the jib boom lift cylinder.
- 10 Attach a strap from an overhead crane to the lug on the rod end of the jib boom cylinder.
- 11 Use a soft metal drift to remove the jib boom lift cylinder rod-end pin. Remove the cylinder from the machine.

AWARNING Crushing hazard. The jib boom lift cylinder will fall when it is removed if it is not properly supported.

3-3 Jib Boom Rotator

The jib boom rotator is a hydraulically activated helical gear assembly used to rotate the jib boom 180 degrees.

How to Remove the Jib Boom Rotator

NOTICE When removing a hose assembly or fitting, the O-ring on the fitting and/or hose end must be replaced and then torqued to specification during installation. Refer to Section Two, *Hydraulic Hose and Fitting Torque Specifications*.

- 1 Remove the platform. See 2-1, *How to Remove the Platform*.
- 2 Remove the jib boom. See 3-1, *How to Remove the Jib Boom*.
- 3 Tag, disconnect and plug the hydraulic hoses from the jib boom rotator manifold. Cap the fittings on the manifold.

AWARNING Bodily injury hazard. Spraying hydraulic oil can penetrate and burn skin. Loosen hydraulic connections very slowly to allow the oil pressure to dissipate gradually. Do not allow oil to squirt or spray.

JIB BOOM COMPONENTS

- 4 Pull the jib rotator hoses out through the jib boom rotator.

CAUTION Component damage hazard. Hoses can be damaged if they are kinked or pinched.

- 5 Support the jib boom rotator with a lifting device. Do not apply any lifting pressure.
- 6 Remove the pin retaining fasteners from the upper arm and upper leveling arm to the jib boom rotator pivot pins. Do not remove the pins.
- 7 Attach a lifting strap from an overhead crane to the upper leveling arm at the jib boom rotator. Do not apply any lifting pressure.
- 8 Use a soft metal drift to remove the upper leveling arm pivot pin.
- 9 Place a 4 x 4 x 8 inch (10 x 10 x 20 cm) block of wood between the upper boom arm and upper leveling arm. Lower the upper leveling arm onto the block.
- 10 Attach a lifting strap from an overhead crane to the jib boom rotator.
- 11 Use a soft metal drift to remove the upper boom pivot pin from the jib boom rotator. Remove the jib boom rotator from the machine.

CAUTION Crushing hazard. The jib boom rotator may fall if it is not properly supported.

How to Bleed the Jib Boom Rotator

- 1 Connect a clear hose to the top bleed valve. Place the other end of the hose in a container to collect any discharge.

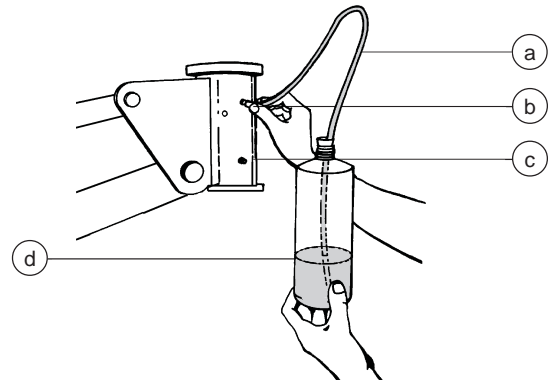

- a clear hose
- b top bleed valve
- c bottom bleed valve
- d container

- 2 Open the top bleed valve, but do not remove it.
- 3 Turn the key switch to ground control and pull out the Emergency Stop button to the ON position.

JIB BOOM COMPONENTS

- 4 Hold the function enable switch to either side and move the jib boom rotate toggle switch in the **RIGHT** direction for approximately 5 seconds, then release it. Repeat three times.

CAUTION Crushing hazard. Keep hands clear of the jib boom pivot weldment during rotation.

- 5 Hold the function enable switch to either side and move the jib boom rotate toggle switch in the **LEFT** direction for approximately 5 seconds, then release it. Repeat three times.
- 6 Fully rotate the jib boom in the **LEFT** direction and continue holding the jib boom rotate toggle switch until air stops coming out of the bleed valve. Immediately release the jib boom rotate switch and close the bleed valve.
- 7 Rotate the jib boom to the right until it is centered.
- 8 Connect the clear hose to the bottom bleed valve and open the valve.
- 9 Rotate the jib boom in the **RIGHT** direction and continue holding the jib boom rotate toggle switch until air stops coming out of the bleed valve.

CAUTION Crushing hazard. Keep hands clear of the jib boom pivot weldment during rotation.

- 10 Close the bleed valve and remove the hose.
- 11 Turn the key switch to the **OFF** position and clean up any hydraulic oil that may have spilled.
- 12 Turn the key switch to ground control and pull out the Emergency Stop button to the **ON** position.
- 13 Hold the function enable switch to either side and move the jib boom rotate toggle switch to the full right and left directions and inspect the bleed valves for leaks.

Boom Components

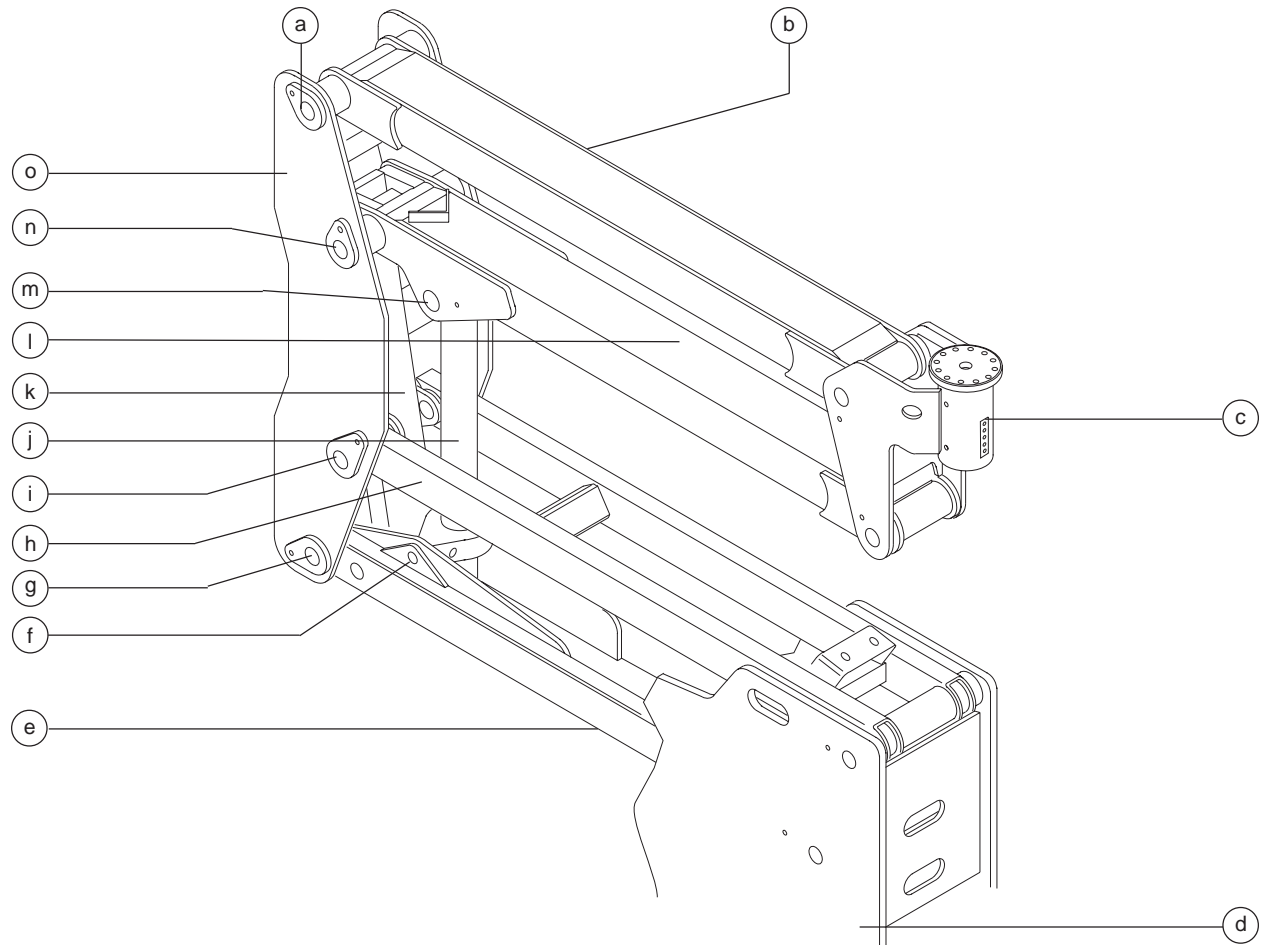

- a Upper leveling arm pivot pin
- b Upper leveling arm
- c Jib boom rotator
- d Chassis pivot
- e Lower boom
- f Lift cylinder barrel end pins (2 pins)
- g Lower boom pivot pin
- h Lower leveling arm
- i Lower leveling arm pivot pins (2 pins)
- j Lift cylinder
- k Compression arm
- l Upper boom
- m Lift cylinder rod end pin
- n Upper boom pivot pin
- o Mid-pivot

BOOM COMPONENTS

4-1 Boom

How to Disassemble the Boom

WARNING Bodily injury hazard. This procedure in this section requires specific repair skills, lifting equipment and a suitable workshop. Attempting this procedure without these skills and tools could result in death or serious injury and significant component damage. Dealer service is required.

Follow the disassembly steps to the point required to complete the repair. Then re-assemble the boom by following the disassembly steps in reverse order.

NOTICE When removing a hose assembly or fitting, the O-ring on the fitting and/or hose end must be replaced and then torqued to specification during installation. Refer to Section Two, *Hydraulic Hose and Fitting Torque Specifications*.

- 1 Remove the platform. See 2-1, *How to Remove the Platform*.
- 2 Remove the jib boom. See 3-1, *How to Remove the Jib Boom*.
- 3 Remove the jib boom rotator. See 3-3, *How to Remove the Jib Boom Rotator*.

- 4 Disconnect the battery packs from the machine.
- 5 Remove the cable cover retaining fasteners from the upper boom. Remove the cable cover.
- 6 Locate the cable that enters the platform controls that was attached to the jib manifold. Do not disconnect this cable.
- 7 Locate the remaining 4 cables that enter the platform control box. Number each cable and its entry location at the platform control box.
- 8 Open the platform control box. Label and disconnect each wire of the 4 cables in the platform control box.

WARNING Electrocutation hazard. Contact with electrically charged circuits could result in death or serious injury. Remove all rings, watches and other jewelry.

- 9 Pull the 4 cables out of the platform control box.
- 10 Pull all of the cables and hoses through the mid-pivot and then lay off to the side.

CAUTION Component damage hazard. Cables and hoses can be damaged if they are kinked or pinched.

- 11 Remove the pin retaining fasteners from the upper leveling arm pivot pin at the mid-pivot. Do not remove the pin.

BOOM COMPONENTS

12 Center a lifting strap from an overhead crane to the upper leveling arm.

13 Use a soft metal drift to remove the upper leveling arm pivot pin at the mid-pivot. Remove the upper leveling arm from the machine.

WARNING Crushing hazard. If the overhead crane is not properly attached, the upper leveling arm could become unbalanced and fall when it is removed from the machine.

14 Tag and disconnect the wiring from the flashing beacon (if equipped).

15 Remove the flashing beacon bracket mounting fasteners, then remove the flashing beacon from the machine (if equipped).

16 Remove the pin retaining fasteners from the rod-end pivot pin of the boom lift cylinder. Use a soft metal drift to remove the pin.

17 Carefully lay the cylinder against the cross tube on the lower leveling arm.

18 Remove the retaining fasteners from the compression arm on the upper boom. Use a soft metal drift to remove the pin out through the access holes in the side of the mid-pivot.

19 Center a lifting strap from the overhead crane to the upper boom.

20 Remove the pin retaining fasteners from the upper boom pivot pin at the mid-pivot.

21 Use a soft metal drift to remove the pin. Remove the upper boom from the machine.

WARNING Crushing hazard. If the overhead crane is not properly attached, the upper boom could become unbalanced and fall when it is removed from the machine.

22 Attach a lifting strap from an overhead crane to the top of the mid pivot.

23 Raise the mid-pivot so the lower boom pivot pin is above the chassis counterweights.

24 Place a 4 x 4 x 36 (10 x 10 x 20 cm) inch block across the top of the chassis counterweights and carefully lower the boom assembly onto the block.

25 Attach a lifting strap from an overhead crane to the lug on the rod end of the boom lift cylinder.

26 Tag, disconnect and plug the hydraulic hoses from the boom lift cylinder. Cap the fittings on the cylinder.

WARNING Bodily injury hazard. Spraying hydraulic oil can penetrate and burn skin. Loosen hydraulic connections very slowly to allow the oil pressure to dissipate gradually. Do not allow oil to squirt or spray.

27 Remove the pin retaining fasteners from the barrel-end pivot pins on the boom lift cylinder. Use a slide hammer to remove the pins.

BOOM COMPONENTS

28 Carefully remove the cylinder from the machine.

▲WARNING Crushing hazard. If the overhead crane is not properly attached, the lift cylinder could become unbalanced and fall when it is removed from the machine.

29 Attach a lifting strap from an overhead crane to the compression arm.

30 Remove the retaining fastener from the lower compression arm pivot pin.

31 Use a soft metal drift to remove the pin. Remove the compression arm from the machine.

▲WARNING Crushing hazard. If the overhead crane is not properly attached, the compression arm could become unbalanced and fall when it is removed from the machine.

32 Remove the cable covers from the lower leveling arm.

33 Remove the hose clamps from the lower leveling arm.

34 Pull the cables and hoses through the mid-pivot and off of the lower leveling arm and lay them off to the side.

CAUTION Component damage hazard. Cables and hoses can be damaged if they are kinked or pinched.

35 Attach a lifting strap from a overhead crane to the mid-pivot. Do not lift it.

36 Support the lower leveling arm with a lifting device.

▲WARNING Crushing hazard. The lower leveling arm could become unbalanced and fall if it is not properly supported.

37 Remove the pin retaining fasteners from the lower leveling arm pivot pins at both sides of the mid-pivot. Do not remove the pins.

38 Lay a 2 x 4 inch (5 x 10 cm) block of wood across the lower boom at the mid-pivot end to rest the lower leveling arm on.

39 Place a rod through the lower leveling arm pivot pins and twist to remove the pins.

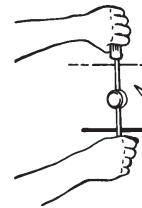

▲WARNING Crushing hazard. If the overhead crane is not properly attached, the mid-pivot could become unbalanced and fall when the lower leveling arm pivot pin is removed.

40 Lower the leveling arm onto the block of wood.

41 Remove the pin retaining fastener from the lower boom pivot pin at the mid-pivot.

BOOM COMPONENTS

42 Use a soft metal drift to remove the lower boom pivot pin. Remove the mid-pivot from the machine.

▲WARNING Crushing hazard. If the overhead crane is not properly attached, the mid pivot could become unbalanced and fall when it is removed from the machine.

43 Center a lifting strap from an overhead crane on the lower leveling arm.

44 Remove the pin retaining fasteners from the lower leveling arm pivot pin at the chassis pivot. Use a soft metal drift to remove the pin.

45 Remove the lower leveling arm from the machine.

▲WARNING Crushing hazard. If the overhead crane is not properly attached, the lower leveling arm could become unbalanced and fall when it is removed from the machine.

46 Tag and disconnect the wires at the quick disconnect terminals near the tilt sensor.

47 Tag and disconnect the wiring from the horn.

48 Remove the pin retaining fasteners from the lower arm pivot pin through the access hole in the chassis counterweight. Do not remove the pin.

49 Center a lifting strap from an overhead crane to the lower arm.

50 Use a soft metal drift to remove the lower arm pivot pin at the chassis pivot. Remove the lower arm from the machine.

▲WARNING Crushing hazard. If the overhead crane is not properly attached, the lower arm could become unbalanced and fall when it is removed from the machine.

CAUTION Component damage hazard. Keep the lower arm clear of the level sensor during removal.

BOOM COMPONENTS

4-2 Boom Lift Cylinder

The boom lift cylinder raises and lowers the boom. The boom lift cylinder is equipped with a counterbalance valve to prevent movement in the event of a hydraulic line failure.

How to Remove the Boom Lift Cylinder

▲WARNING Bodily injury hazard. This procedure requires specific repair skills, lifting equipment and a suitable workshop. Attempting this procedure without these skills and tools could result in death or serious injury and significant component damage. Dealer service is strongly recommended.

▲NOTICE When removing a hose assembly or fitting, the O-ring on the fitting and/or hose end must be replaced and then torqued to specification during installation. Refer to Section Two, *Hydraulic Hose and Fitting Torque Specifications*.

- 1 Raise the boom so that the lower boom pivot pin at the mid-pivot is above the chassis counterweights.
- 2 Place a 4 x 4 x 36 inch (10 x 10 x 91 cm) block across the top of the chassis counterweights and carefully lower the boom assembly on to the block.

- 3 Attach an overhead crane to the jib boom rotator for support. Do not lift it.
- 4 Tag, disconnect and plug the hydraulic hoses on the boom lift cylinder. Cap the fittings on the boom lift cylinder.

▲WARNING Bodily injury hazard. Spraying hydraulic oil can penetrate and burn skin. Loosen hydraulic connections very slowly to allow the oil pressure to dissipate gradually. Do not allow oil to squirt or spray.

- 5 Remove the pin retaining fasteners from the boom lift cylinder barrel-end pivot pins.
- 6 Use a slide hammer to remove the boom lift cylinder barrel-end pivot pins.
- 7 Attach a lifting strap from an overhead crane to the lug on the rod end of the boom lift cylinder.
- 8 Remove the pin retaining fastener from the boom lift cylinder rod-end pivot pin. Use a soft metal drift to remove the pin.
- 9 Carefully remove the cylinder from the machine.

▲WARNING Crushing hazard. If the boom lift cylinder is not properly supported, the cylinder could become unbalanced and fall when it is removed from the machine.

Ground Controls

5-1 Toggle Switches

See 1-4, *Toggle Switches*.

5-2 Control Relays

See 1-5, *Control Relays*.

5-3 Wago® Components

How to Remove a Wago® Component

⚠ WARNING Electrocutation hazard. Contact with electrically charged circuits could cause death or serious injury. Remove all rings, watches and other jewelry.

NOTICE Wago® tools are available from the Genie Service Parts Department (Genie part number 33996).

- 1 Label the wiring from the component to be removed.
- 2 Use a small screwdriver to push in and release the wire from the component.
- 3 Locate the removal tab on the bottom or top of the component.
- 4 Use a small screwdriver to gently pry up on the tab of the component and remove it.

Hydraulic Pumps

6-1 Auxiliary Pump

How to Test the Auxiliary Pump

NOTICE When removing a hose assembly or fitting, the O-ring on the fitting and/or hose end must be replaced and then torqued to specification during installation. Refer to Section Two, *Hydraulic Hose and Fitting Torque Specifications*.

- 1 Disconnect and plug the high pressure hydraulic hose from the auxiliary pump at the function manifold.

AWARNING Bodily injury hazard. Spraying hydraulic oil can penetrate and burn skin. Loosen hydraulic connections very slowly to allow the oil pressure to dissipate gradually. Do not allow oil to squirt or spray.

- 2 Connect a 0 to 5000 psi (0 to 345 bar) pressure gauge to the high pressure port from the pump.
- 3 Turn the key switch to ground control and pull out the Emergency Stop button to the ON position.

- 4 Activate any function using auxiliary power.
- ⊙ Result: If the pressure gauge reads 3500 psi (241 bar), immediately stop. The pump is good.
- ⊙ Result: If pressure fails to reach 3500 psi (241 bar), the internal relief valve setting is incorrect or the pump is bad and will need to be serviced or replaced.
- 5 Remove the pressure gauge and reconnect the hydraulic hose.

How to Remove the Auxiliary Pump

- 1 Open both battery trays and disconnect the battery packs from the machine.
- 2 Support the ground controls side battery tray with a forklift or suitable lifting device.
- 3 Remove the retaining fasteners that attach the roller stop blocks to the battery pack tray slides. Remove the roller stop blocks.
- 4 Carefully slide the battery tray out of the chassis.

CAUTION Crushing hazard. If the battery tray is not properly supported, it may become unbalanced and fall when it is removed from the machine.

HYDRAULIC PUMPS

- 5 Tag and disconnect the power cables from the auxiliary power unit.

⚠WARNING Electrocutation hazard. Contact with electrically charged circuits could result in death or serious injury. Remove all rings, watches and other jewelry.

- 6 Tag, disconnect and plug the hydraulic hoses from the pump. Cap the fittings on the pump.

⚠WARNING Bodily injury hazard. Spraying hydraulic oil can penetrate and burn skin. Loosen hydraulic connections very slowly to allow the oil pressure to dissipate gradually. Do not allow oil to squirt or spray.

- 7 Remove the auxiliary power unit mounting fasteners. Carefully remove the auxiliary power unit.
- 8 Remove the pump mounting bolts. Remove the pump from the electric motor.

6-2 Main Function Pump

How to Test the Main Function Pump

The main function pump has 2 sections. One section is used for boom and steer functions, and when driving the output of both sections are combined.

NOTICE When removing a hose assembly or fitting, the O-ring on the fitting and/or hose end must be replaced and then torqued to specification during installation. Refer to Section Two, *Hydraulic Hose and Fitting Torque Specifications*.

- 1 Disconnect and plug the high pressure hydraulic hose from the section closest to the electric motor on the main function pump.

⚠WARNING Bodily injury hazard. Spraying hydraulic oil can penetrate and burn skin. Loosen hydraulic connections very slowly to allow the oil pressure to dissipate gradually. Do not allow oil to squirt or spray.

- 2 Connect a 0 to 5000 psi (0 to 345 bar) pressure gauge to the high pressure port on the pump.

HYDRAULIC PUMPS

- 3 Turn the key switch to platform control and pull out the Emergency Stop button to the ON position at both the ground and platform controls.
- 4 Press down on the foot switch and activate the drive function.
 - ⦿ Result: If the pressure gauge reads 3500 psi (241 bar), immediately stop. The pump is good.
 - ⦿ Result: If pressure fails to reach 3500 psi (241 bar), the drive section of the pump is bad and will need to be serviced or replaced.
- 5 Disconnect and plug the high pressure hydraulic hose from the section farthest from the electric motor on the main function pump.

⚠WARNING Bodily injury hazard. Spraying hydraulic oil can penetrate and burn skin. Loosen hydraulic connections very slowly to allow the oil pressure to dissipate gradually. Do not allow oil to squirt or spray.

- 6 Connect a 0 to 5000 psi (0 to 345 bar) pressure gauge to the high pressure port on the pump that is farthest from the electric motor.
- 7 Turn the key switch to ground control and pull out the Emergency Stop button to the ON position at both the ground and platform controls.

- 8 Activate the function enable switch and the platform up function from the ground controls.
 - ⦿ Result: If the pressure gauge reads 2500 psi (172 bar), immediately stop. The pump is good.
 - ⦿ Result: If pressure fails to reach 2500 psi (172 bar), the function and steer section of the pump is bad and will need to be serviced or replaced.
- 9 Remove the pressure gauge and reconnect the hydraulic hoses.

How to Remove the Main Function Pump

- 1 Tag, disconnect and plug the hydraulic hoses on the pump.

⚠WARNING Bodily injury hazard. Spraying hydraulic oil can penetrate and burn skin. Loosen hydraulic connections very slowly to allow the oil pressure to dissipate gradually. Do not allow oil to squirt or spray.

- 2 Remove the pump mounting bolts. Carefully remove the pump.

Manifolds

7-1

Function Manifold Components

The function manifold is mounted to the slide-out component tray located at the non-steer end of the machine.

Index No.	Description	Schematic Item	Function	Torque
1	3 position 4 way solenoid valve	A	Steering left/right	10-12 ft-lbs (14-16 Nm)
2	Diagnostic fitting		Testing	
3	Check valve	B	Main pump	25-30 ft-lbs (34-41 Nm)
4	2 position 4 way solenoid valve	C	High/low drive speed	10-12 ft-lbs (14-16 Nm)
5	Orifice, 0.030 in (0.76 mm)	D	Brake circuit	
6	Shuttle valve	E	Brake circuit	10-12 ft-lbs (10-15 Nm)
7	2 position 2 way N.O. poppet valve ..	F	Pump unload	4-6 ft-lbs (5-8 Nm)
8	2 position 2 way N.O. solenoid valve	G	Jib/rotate bypass	25-30 ft-lbs (34-41 Nm)
9	Relief valve, 1400 psi (97 bar)	H	Drive circuit	35-40 ft-lbs (47-54 Nm)
10	2 position 3 way solenoid valve	I	Drive reverse	10-12 ft-lbs (14-16 Nm)
11	2 position 3 way solenoid valve	J	Drive forward	10-12 ft-lbs (14-16 Nm)
12	2 position 2 way N.O. poppet valve ..	K	Steer dump	4-6 ft-lbs (5-8 Nm)
13	2 position 2 way N.O. poppet valve ..	L	Brake unload	4-6 ft-lbs (5-8 Nm)
14	Orifice, 0.030 in (0.76 mm)	M	Brake circuit	
15	Priority flow regulator 0.75 gpm (2.8 L/min)	N	Steer/jib boom rotate	10-12 ft-lbs (14-16 Nm)
16	Relief valve, 3500 psi (241 bar)	O	System relief	35-40 ft-lbs (47-54 Nm)
17	Check valve	P	Main pump	25-30 ft-lbs (34-41 Nm)
18	2 position 3 way solenoid valve	Q	Boom down	25-30 ft-lbs (34-41 Nm)
19	2 position 3 way solenoid valve	R	Boom up	25-30 ft-lbs (34-41 Nm)
20	Relief valve, 2500 psi (172 bar)	S	Steering relief	35-40 ft-lbs (47-54 Nm)
21	Relief valve, 1500 psi (103 bar)	T	Boom down	35-40 ft-lbs (47-54 Nm)

Plug Torque Specifications

Description	Hex Size	Torque	Description	Hex Size	Torque
SAE No. 2	1/8	50 in-lbs / 6 Nm	SAE No. 6	1/4	18 ft-lbs / 24 Nm
SAE No. 4	3/16	13 ft-lbs / 18 Nm	SAE No. 8	5/16	50 ft-lbs / 68 Nm

MANIFOLDS

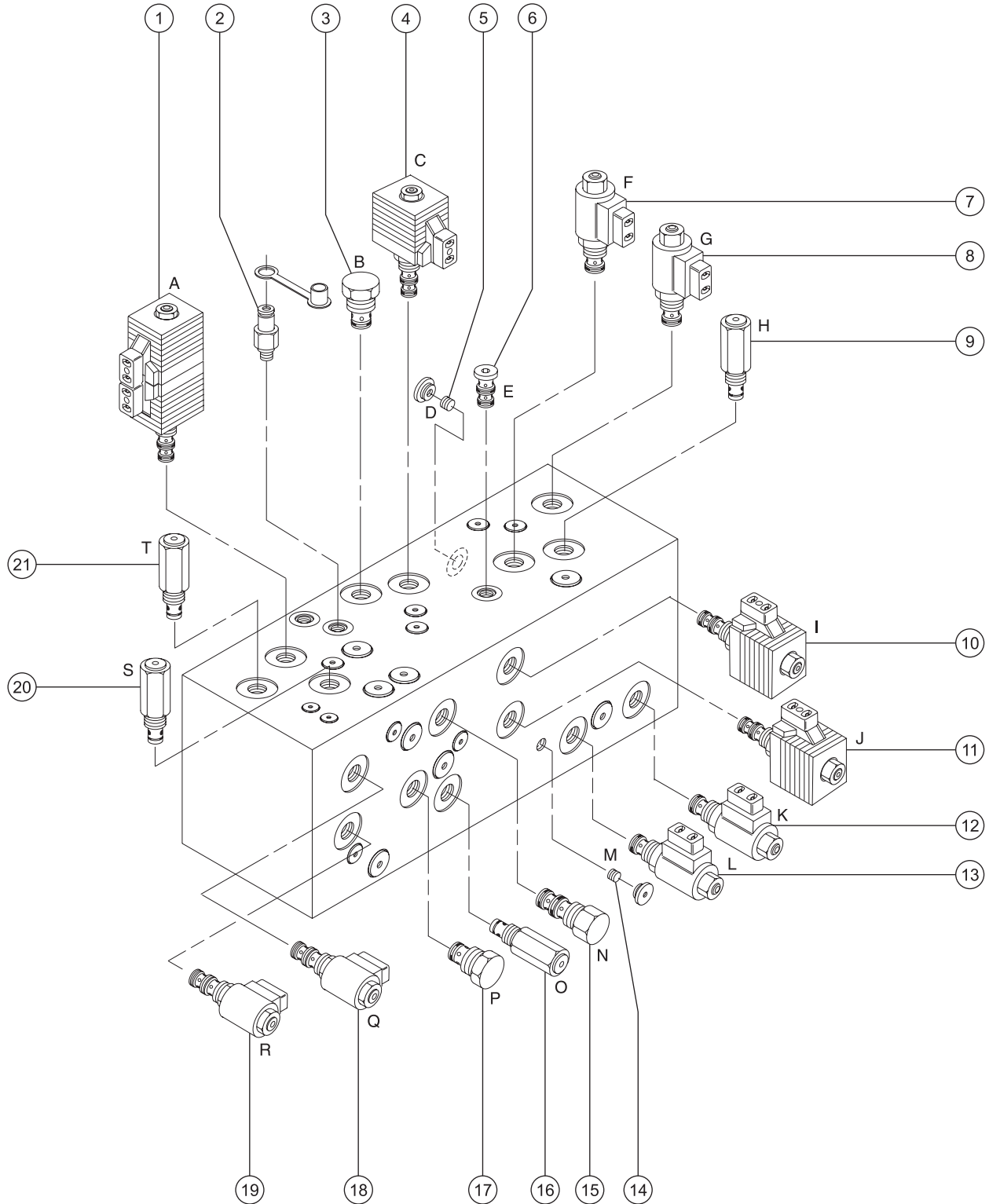

MANIFOLDS

7-2 Valve Adjustments - Function Manifold

How to Adjust the System Relief Valve

NOTICE Perform this procedure with the boom in the stowed position.

- 1 Connect a 0 to 5000 psi (0 to 345 bar) pressure gauge to the test port on the function manifold.
- 2 Turn the key switch to ground control and pull out the Emergency Stop button to the ON position.
- 3 Activate the function enable switch and hold the boom up switch with the boom fully raised. Observe the pressure reading on the pressure gauge.

System relief valve specifications

Pressure	3500 psi 241 bar
----------	---------------------

- 4 Turn the machine off. Hold the relief valve and remove the cap (item O, function manifold).
- 5 Adjust the internal hex socket. Turn it clockwise to increase the pressure or counterclockwise to decrease the pressure. Install the relief valve cap.

WARNING Tip-over hazard. Do not adjust the relief valve higher than specified.

- 6 Repeat steps 2 through 5 to confirm the relief valve pressure.

How to Adjust the Boom Down Relief Valve

NOTICE Perform this procedure with the boom in the stowed position.

- 1 Connect a 0 to 3000 psi (0 to 206 bar) pressure gauge to the test port on the function manifold.
- 2 Turn the key switch to ground control and pull out the Emergency Stop button to the ON position.
- 3 Activate the function enable switch and hold the boom down switch with the boom fully lowered. Observe the pressure reading on the pressure gauge.

Boom down relief valve specifications

Pressure	1500 psi 103 bar
----------	---------------------

- 4 Turn the machine off. Hold the relief valve and remove the cap (item T, function manifold).
- 5 Adjust the internal hex socket. Turn it clockwise to increase the pressure or counterclockwise to decrease the pressure. Install the relief valve cap.

WARNING Tip-over hazard. Do not adjust the relief valve higher than specified.

- 6 Repeat steps 2 through 5 to confirm the relief valve pressure.

MANIFOLDS

How to Adjust the Steer Relief Valve

NOTICE Perform this procedure with the boom in the stowed position.

- 1 Connect a 0 to 3000 psi (0 to 206 bar) pressure gauge to the test port on the function manifold.
- 2 Turn the key switch to platform controls and pull out the Emergency Stop buttons to the ON position at both the platform and ground controls.
- 3 Hold the steer rocker switch in either direction until the steer wheels are fully turned, and observe the reading on the pressure gauge.

Steer relief valve specifications

Pressure	2500 psi 172 bar
----------	---------------------

- 4 Turn the machine off. Hold the relief valve and remove the cap (item S, function manifold).
- 5 Adjust the internal hex socket. Turn it clockwise to increase the pressure or counterclockwise to decrease the pressure. Install the relief valve cap.
- 6 Repeat steps 2 through 5 to confirm the relief valve pressure.

How to Adjust the Drive Relief Valve

NOTICE For adjustment procedure, please contact Genie Industries Service Department.

Valve Coil Resistance Specifications

Valve coil specifications

2 position 2 way poppet valve - 20V (schematic items F, G, K and L)	23 - 24Ω
2 position 3 way solenoid valve - 20V (schematic items I, J, Q and R)	23 - 24Ω
2 position 4 way solenoid valve - 20V (schematic item C)	21 - 23Ω
3 position 4 way solenoid valve - 20V (schematic item A)	21 - 23Ω

MANIFOLDS

7-3

Jib Boom and Jib Boom Rotate Manifold Components

The Jib Boom/Jib Rotate manifold is mounted to the jib boom.

Index No.	Description	Schematic Item	Function	Torque
1	2 position 3 way spool valve	U	Jib boom up	8-10 ft-lbs (11-14 Nm)
2	2 position 3 way spool valve	V	Jib boom rotate right	8-10 ft-lbs (11-14 Nm)
3	Orifice, 0.030 in (0.76 mm)	W	Jib boom functions	
4	Orifice, 0.025 in (0.64 mm)	X	Jib boom rotate circuit	
5	2 position 3 way spool valve	Y	Jib boom rotate left	8-10 ft-lbs (11-14 Nm)
6	2 position 3 way spool valve	Z	Jib boom down	8-10 ft-lbs (11-14 Nm)

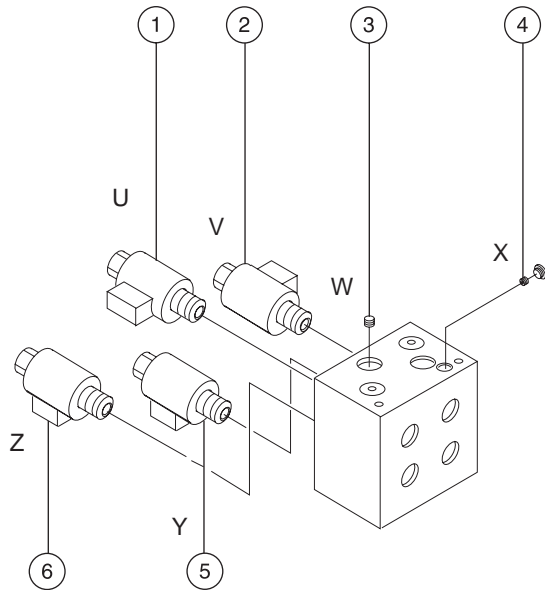

Plug Torque Specifications

Description	Hex Size	Torque
SAE No. 2	1/8	50 in-lbs / 6 Nm
SAE No. 4	3/16	13 ft-lbs / 18 Nm

Valve Coil Resistance Specifications

Valve coil specification	
2 position 3 way valve - 20V (schematic items U, V, Y and Z)	23.5 to 24.5Ω

MANIFOLDS

7-4 Brake Release Hand Pump Components

The brake release hand pump manifold is mounted to the drive chassis at the non-steer end above the hydraulic component tray.

Index No.	Description	Schematic Item	Function	Torque
1	Check valve, pilot operated	AA	Manual brake release	25-30 ft-lbs (34-41 Nm)
2	Shuttle valve	BB	Brake release	8-10 ft-lbs (11-14 Nm)
3	Hand pump	CC	Manual brake release	25-30 ft-lbs (34-41 Nm)

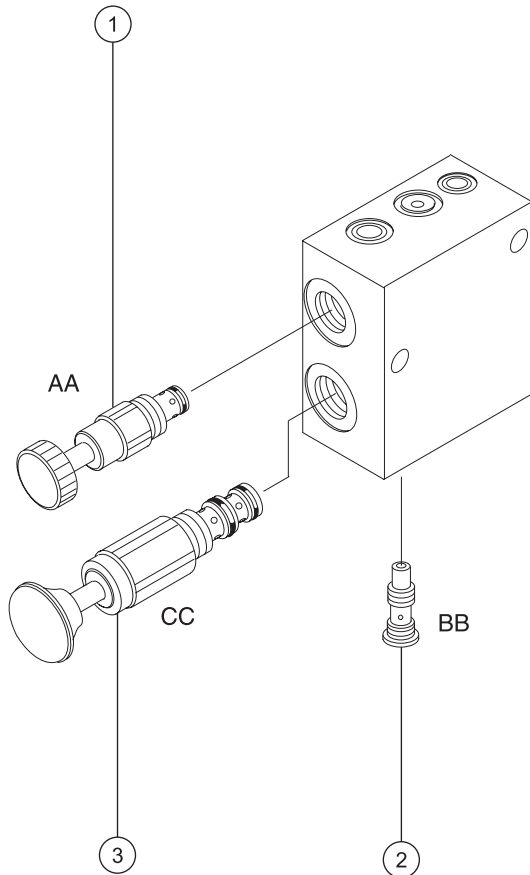

Plug Torque Specifications

Description	Hex Size	Torque
SAE No. 2	1/8	50 in-lbs / 6 Nm
SAE No. 4	3/16	13 ft-lbs / 18 Nm

Steer Axle Components

8-1 Yoke and Drive Motor

How to Remove the Yoke and Drive Motor

NOTICE When removing a hose assembly or fitting, the O-ring on the fitting and/or hose end must be replaced and then torqued to specification during installation. Refer to Section Two, *Hydraulic Hose and Fitting Torque Specifications*.

- 1 Block the non-steering wheels, then center a lifting jack under the drive chassis at the steer end of the machine.
- 2 Remove the cotter pin from the wheel castle nut.
- 3 Loosen the wheel castle nut. Do not remove it.

- 4 Raise the machine approximately 12 inches (30 cm). Place blocks under the chassis for support.

WARNING Crushing hazard. The chassis will fall if it is not properly supported.

- 5 Remove the castle nut, then remove the wheel.
- 6 Tag, disconnect and plug the hoses on the drive motor. Cap the fittings on the drive motor.

WARNING Bodily injury hazard. Spraying hydraulic oil can penetrate and burn skin. Loosen hydraulic connections very slowly to allow the oil pressure to dissipate gradually. Do not allow oil to squirt or spray.

- 7 Support and secure the yoke assembly to a suitable lifting device.
- 8 Remove the fasteners that attach the steer link to the bellcrank.
- 9 Remove the retaining fastener from the top of the yoke pivot shaft.

NOTICE Access the yoke pivot shaft fasteners behind the chassis counterweight.

STEER AXLE COMPONENTS

10 Lower the yoke assembly out of the chassis while guiding the steer link out of the bellcrank.

CAUTION Crushing hazard. The yoke/motor assembly may fall if it is not properly supported and secured to the lifting device when it is removed from the chassis.

NOTICE During assembly, be sure to use anti-sieze compound or lightly grease the drive motor shaft before installing the wheel.

NOTICE Always use a new cotter pin when installing a castle nut.

Castle Nut torque specifications

Castle nut torque, dry	300 ft-lbs	406.7 Nm
Castle nut torque, lubricated	225 ft-lbs	305 Nm

How to Remove a Drive Motor

- 1 Block the non-steering wheels, then center a lifting jack under the drive chassis at the steer end of the machine.
- 2 Remove the cotter pin on the wheel castle nut of the motor to be removed.
- 3 Loosen the wheel castle nut. Do not remove it.
- 4 Raise the machine 2 inches (5 cm) and place blocks under the drive chassis for support.

WARNING Crushing hazard. The chassis will fall if it is not properly supported.

5 Remove the wheel castle nut then remove the wheel.

6 Tag, disconnect and plug the hydraulic hoses on the drive motor. Cap the fittings on the drive motor.

WARNING Bodily injury hazard. Spraying hydraulic oil can penetrate and burn skin. Loosen hydraulic connections very slowly to allow the oil pressure to dissipate gradually. Do not allow oil to squirt or spray.

7 Remove the drive motor mounting fasteners, then remove the motor.

NOTICE Always use a new cotter pin when installing a castle nut.

NOTICE During assembly, be sure to use anti-sieze compound or lightly grease the drive motor shaft when installing the wheel.

Castle Nut torque specifications

Castle nut torque, dry	300 ft-lbs	406.7 Nm
Castle nut torque, lubricated	225 ft-lbs	305 Nm

STEER AXLE COMPONENTS

8-2 Steering Cylinder

How to Remove the Steering Cylinder

NOTICE When removing a hose assembly or fitting, the O-ring on the fitting and/or hose end must be replaced and then torqued to specification during installation.
Refer to Section Two, *Hydraulic Hose and Fitting Torque Specifications*.

- 1 Block the non-steer wheels and center a lifting jack under the drive chassis at the steer end.
- 2 Raise the machine approximately 12 inches (30 cm). Place blocks under the chassis for support.

WARNING Crushing hazard. The chassis will fall if it is not properly supported.

- 3 Tag, disconnect and plug the hydraulic hoses from the steering cylinder. Cap the fittings on the cylinder.

WARNING Bodily injury hazard. Spraying hydraulic oil can penetrate and burn skin. Loosen hydraulic connections very slowly to allow the oil pressure to dissipate gradually. Do not allow oil to squirt or spray.

- 4 Remove the cotter pin from the barrel end clevis pin. Remove the clevis pin.

NOTICE Always use a new cotter pin when installing a clevis pin.

- 5 Remove the cotter pin from the rod end clevis pin. Remove the clevis pin.

NOTICE Always use a new cotter pin when installing a clevis pin.

- 6 Remove the steering cylinder from the machine.

STEER AXLE COMPONENTS

8-3 Steering Bellcrank

How to Remove the Steering Bellcrank

NOTICE When removing a hose assembly or fitting, the O-ring on the fitting and/or hose end must be replaced and then torqued to specification during installation. Refer to Section Two, *Hydraulic Hose and Fitting Torque Specifications*.

- 1 Block the non-steer wheels and center a lifting jack under the drive chassis at the steer end.
- 2 Raise the machine approximately 12 inches (30 cm). Place blocks under the chassis for support.

WARNING Crushing hazard. The chassis will fall if it is not properly supported.

- 3 Remove the cotter pin from the rod end clevis pin of the steer cylinder. Remove the clevis pin.

NOTICE Always use a new cotter pin when installing a clevis pin.

- 4 Tag, disconnect and plug the hydraulic hoses from the ground controls side drive motor. Cap the fittings on the drive motor.

WARNING Bodily injury hazard. Spraying hydraulic oil can penetrate and burn skin. Loosen hydraulic connections very slowly to allow the oil pressure to dissipate gradually. Do not allow oil to squirt or spray.

- 5 Pull the hydraulic hoses from the ground controls side drive motor out through the steer bellcrank.

CAUTION Component damage hazard. Hoses can be damaged if they are kinked or pinched.

- 6 Remove the cotter pin from the bellcrank center clevis pivot pin. Remove the clevis pin.

NOTICE Always use a new cotter pin when installing a clevis pin.

- 7 Remove the fasteners that attach the steer links to the bellcrank.
- 8 Remove the bellcrank from the machine out the ground controls side of the machine.

How to Perform the Toe-in Adjustment

Z-25/8 after serial number 211

Z-20/8 after serial number 121

Z-20/8N after serial number 895:

NOTICE Always perform this procedure on a firm, level, surface. Block the non-steer wheels and be sure that the unit is in the stowed position.

- 1 Straighten the ground control side steer wheel.
- 2 Measure the steer tires, front to front and back to back, using a measuring device.

STEER AXLE COMPONENTS

- 3 Block the non-steer wheels.
- 4 Center a lifting jack under the front of the chassis and raise the machine until the steer wheels are off the ground. Place blocks under the chassis for support.

⚠WARNING Crushing hazard. The chassis will fall if it is not properly supported.

- 5 Locate the toe-in adjustment bolt located on the top of the motor controller side steering yoke.
- 6 Remove the lock nut from the adjustment bolt.
- 7 Pull the adjustment bolt out so it clears the set pin and turn it clockwise or counterclockwise to adjust the tow-in of the steer wheels.
- 8 Lower adjustment bolt between the selected notch and the set pin. Install the lock nut.
- 9 Lower the machine and repeat step 2.
- 10 If further adjustment is needed, repeat steps 4 through 9.

Toe-in Specification 0 to 1/4 inch (0 to 6.4 mm)

Non-steering Axle Components

9-1 Drive Brake

How to Remove a Drive Brake

NOTICE When removing a hose assembly or fitting, the O-ring on the fitting and/or hose end must be replaced and then torqued to specification during installation. Refer to Section Two, *Hydraulic Hose and Fitting Torque Specifications*.

- 1 Block the steer wheels and center a lifting jack under the drive chassis at the non-steer end.
- 2 Remove the cotter pin on the wheel castle nut.

NOTICE Always use a new cotter pin when installing a castle nut.

- 3 Loosen the wheel castle nut. Do not remove it.
- 4 Raise the machine 2 inches (5 cm) and place blocks under the drive chassis for support.

WARNING Crushing hazard. The chassis will fall if it is not properly supported.

- 5 Remove the wheel castle nut then remove the wheel.

- 6 Disconnect the hydraulic hose from the brake and plug it. Cap the fitting on the brake.

WARNING Bodily injury hazard. Spraying hydraulic oil can penetrate and burn skin. Loosen hydraulic connections very slowly to allow the oil pressure to dissipate gradually. Do not allow oil to squirt or spray.

- 7 Support and secure the brake to a lifting jack.
- 8 Remove the brake mounting fasteners, then remove the brake.

CAUTION Crushing hazard. The brake may fall if it is not properly supported and secured to the lifting jack when the brake mounting fasteners are removed.

NOTICE During assembly, be sure to use anti-sieze or lightly grease the brake shaft when installing the wheel.

Castle Nut torque specifications

Castle nut torque, dry	300 ft-lbs	406.7 Nm
Castle nut torque, lubricated	225 ft-lbs	305 Nm

Distributed By: _____

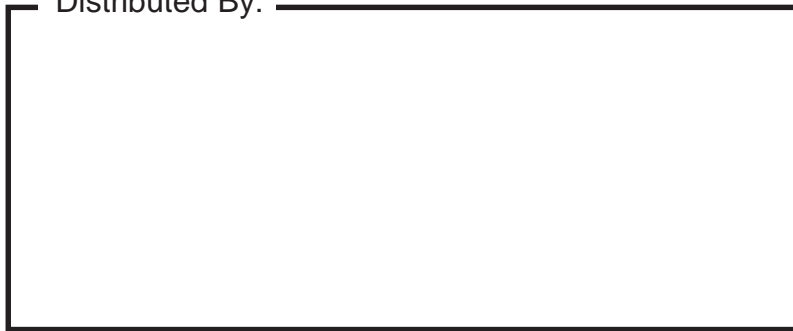

Genie North America

Phone: 425 881 1800
Toll Free in USA
and Canada 800 536 1800
Fax: 425 883 3475

Genie UK Limited

Phone: 44 1636 605030
Fax: 44 1636 611090

Genie China

Phone: 86 21 5385 2570
Fax: 86 21 5385 2569

Genie Japan

Phone: 81 3 3453 6082
Fax: 81 3 3453 6083

Genie Australia Pty Ltd.

Phone: 61 7 3375 1660
Fax: 61 7 3375 1002

Genie France

Phone: 33 237 260 999
Fax: 33 237 260 998

Genie Holland

Phone: 31 7051 78836
Fax: 31 7051 13993

Genie Brasil

Phone: 55 11 4055 2499
Fax: 55 11 713 1661