



# **Technologies in HPE ProLiant Gen10 4-socket servers**

Using the Intel Xeon Scalable Processor Family



# Contents

Abstract .....	3
Introduction.....	3
System architecture.....	4
Why choose 4-socket servers?.....	6
Gen10 versus Gen9 technology .....	6
Standardizing on a single processor family for Gen10.....	6
Sweet spot memory footprint at faster speeds.....	6
Increase in I/O capacity.....	6
HPE Secure Compute Lifecycle.....	7
Processor technologies .....	9
Intelligent System Tuning.....	9
Workload Matching.....	9
Jitter Smoothing.....	10
Core Boosting .....	10
Memory technologies.....	10
HPE DDR4 SmartMemory.....	10
HPE Advanced Memory Error Detection Technology.....	11
HPE Persistent Memory .....	11
HPE NVDIMMs .....	11
HPE server storage .....	11
HPE HDDs.....	12
HPE SSDs .....	12
HPE NVMe PCIe SSDs.....	12
HPE Smart Array Controllers.....	12
HPE Universal Media Bay.....	12
Networking for HPE Gen10 4-socket servers.....	12
Power efficiency and provisioning.....	13
HPE Flexible Slot Power Supply .....	13
HPE 3D Sea of Sensors.....	13
Power provisioning tools.....	13
Managing HPE ProLiant Gen10 servers.....	14
Embedded management with HPE iLO 5.....	14
Converged management using HPE OneView.....	14
HPE Pointnext.....	15
Conclusion.....	15
Additional resources .....	16



## Abstract

While organizations identify the right-mix Hybrid IT to enable today's digital transformation, they also require a foundation that offers the performance, expandability, and security required of business-critical workloads. HPE's 4-socket (4P) ProLiant 500 series Gen10 servers deliver on all fronts. This technical white paper highlights key Gen10 differences versus Gen9 predecessors; discusses changes in the system architecture; and describes, in detail, the technologies used in HPE ProLiant 500 series Gen10 servers and how these innovations can help organizations better address Hybrid IT and diverse workload requirements.

## Introduction

Proven to deliver high performance, expandability, and reliability, more businesses are turning to [HPE ProLiant 500 series servers](#) to handle their most demanding applications. Whether accommodating large database workloads (SAP®, Oracle, and SQL), business critical workloads (ERP, CRM), decision-support applications (business intelligence and analytics), or large-scale consolidation and virtualization, HPE ProLiant 500 series Gen10 4-socket (4P) servers are up to the task.

[Gen10 technology](#) in the HPE ProLiant platform maximizes server performance, enabling a new compute experience across all aspects of the infrastructure. Additionally, powerful 4P servers offer greater protection to secure your digital assets. They provide the scale and agility needed to address growing data volumes and accommodate traditional and emerging workloads. They are also easier than ever to manage and control across your [Hybrid IT environment](#).

The HPE ProLiant 500 series Gen10 portfolio includes:

- **HPE ProLiant DL580 Gen10 Server:** This 4P enterprise standard delivers high performance and expandability for business-critical applications.
- **HPE ProLiant DL560 Gen10 Server:** This resilient, high-density 4P server delivers business-critical computing performance.



HPE ProLiant DL580 Gen10 (shown with 48 SFF drives)



HPE ProLiant DL560 Gen10 (shown with box 1 populated with the Universal Media Bay and boxes 2 and 3 with 8 SFF drives)

**Figure 1.** HPE ProLiant Gen10 4-socket servers

HPE ProLiant Gen10 4-socket servers offer the following differentiating innovations:

- World's most secure industry-standard servers:<sup>1</sup>
  - Unmatched threat protection through the silicon root of trust, extensive standards compliance, and supply chain attack detection
  - Unparalleled ability to recover firmware after denial of service attempt or detection of compromised code
- Intelligent System Tuning:
  - Preconfigured BIOS settings to tune the server to match specific workloads
  - Performance tuning to enable more workloads on more cores at a given CPU frequency for greater application licensing efficiency
  - Predictable latency reduction and balanced workload optimization

<sup>1</sup> Based on external firm conducting cyber security penetration testing of a range of server products from a range of manufacturers, May 2017.



- New levels of compute:
  - Latest generation industry-standard CPUs with faster processing and higher speed memory access
  - Enhanced GPU levels of performance and choice
- Increased in-server storage density: substantially greater NVMe capacity for large write-intensive workloads and enhanced storage density with more SFF drive bays for large database workloads

Table 1 offers a general architectural comparison of HPE ProLiant Gen10 4-socket rack and tower servers.

**Table 1.** Overview of HPE ProLiant Gen10 4-socket servers

	HPE ProLiant DL560 Gen10 Server	HPE ProLiant DL580 Gen10 Server
<b>Form factor</b>	2U rack mount	4U rack mount
<b>Processors</b>	Up to 4 Intel® Xeon® Scalable Processor Family (up to 28 cores, 3.6 GHz; 8100, 6100, and 5100 series)	
<b>System memory</b>	48 slots for HPE SmartMemory DDR4 2666 MT/s DIMMs (maximum of 6 TB)	
<b>Persistent memory</b>	Support for up to 24 NVDIMMs (384 GB maximum)	
<b>Drive bays</b>	24 SFF maximum, HDD/SSD, HPE Universal Media bay optional (2 SFF SAS/SATA/NVMe, 2 SFF or optical/video/USB 2.0), M.2 Enablement Kit, and 12 NVMe SSD option	48 SFF maximum, HDD/SSD, HPE Universal Media bay optional (2 SFF SAS/SATA/NVMe, 2 SFF or optical/video/USB 2.0), and 20 NVMe SSD option
<b>Storage controllers</b>	HPE Smart Array S100i Software RAID; choice of HPE Smart Array Essential and Performance RAID Controllers for additional features	
<b>Universal Media Bay</b>	Yes (optional)	
<b>PCIe slots</b>	8 PCIe 3.0 slots	16 PCIe 3.0 slots
<b>GPU support</b>	Up to 2 HL/FH	Up to 4 dual-wide
<b>Networking</b>	Optional FlexibleLOM and standup	
<b>Power supply units</b>	Up to 4 Flex Slot PSUs (up to 1600W)	
<b>EStar 2.1</b>	1H2018	
<b>ASHRAE operating class</b>	3 and 4*	
<b>Management</b>	HPE iLO 5 Management (standard), Intelligent Provisioning (standard), iLO Advanced (optional), iLO Advanced Premium Security Edition (optional), HPE OneView Advanced (optional)	

\*Compliance to be met 1H2018

## System architecture

HPE ProLiant 4-socket 500 series Gen10 servers deliver enhancements not only in terms of technology but also system design.

Both [HPE ProLiant DL560](#) and [DL580 Gen10 servers](#) have the same processor stack. They also connect the processors in a crossbar pattern (see figures 2 and 3 below), which differs from the ring pattern on the HPE ProLiant DL560 Gen9 Server. This means that each processor is connected to every other processor in a 4P configuration.

The design of the HPE ProLiant DL560 Gen10 is similar to its Gen9 predecessor with a system board including 2 processors and 24 DIMMs, as well as an optional mezzanine board with an additional 2 processors and 24 DIMMs.

The HPE ProLiant DL580 Gen10 server, however, has been completely redesigned from Gen9 and leverages the DL560 design with the system board and the mezzanine tray. The DL580 Gen10 now supports up to 48 drives (up from 10 drives on Gen9), enabling it to support storage-intensive workloads. The memory tray design on the DL580 Gen9 is no longer used and the DIMMs are installed on the system board and the mezzanine board. The I/O count has grown from 9 to 16 and requires risers. It also supports double wide GPU cards. Support for all 16 PCIe slots is only available when all 4 processors are populated.



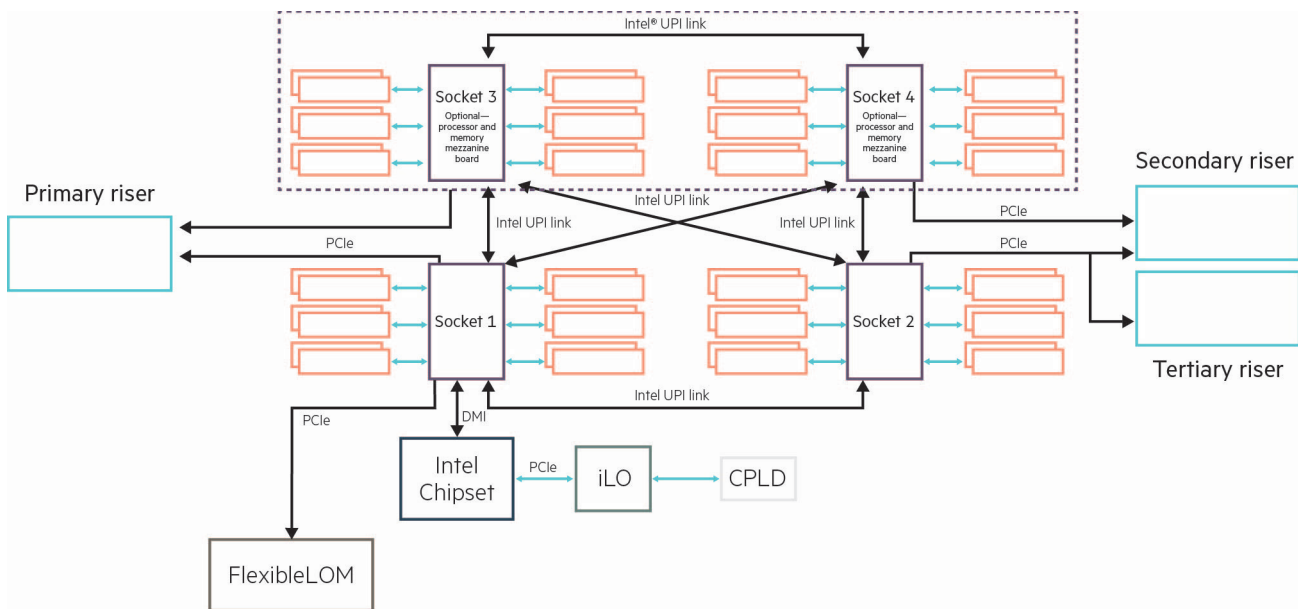

Figure 2. HPE ProLiant DL580 Gen10 server diagram

**Note**

The change in memory architecture from Gen9 to Gen10. Gen10 now has 6 channels and 2DPC (DIMM per channel).

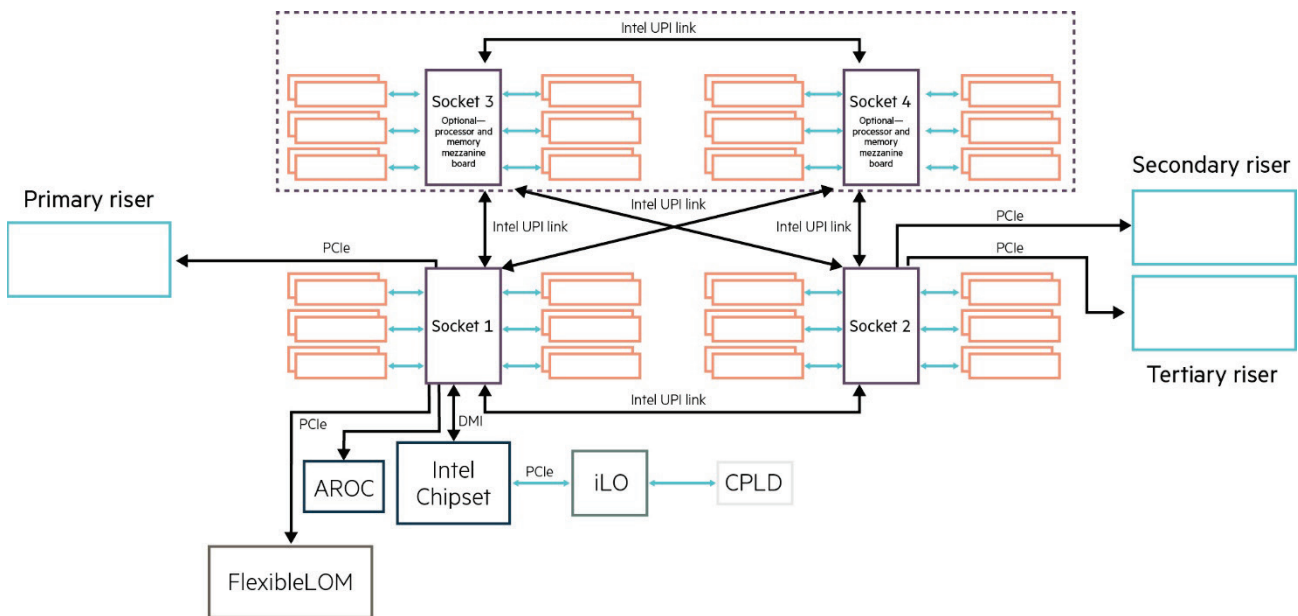

Figure 3. HPE ProLiant DL560 Gen10 Server diagram



## Why choose 4-socket servers?

While compression of the processor stack in HPE ProLiant Gen10 servers blurs boundaries that traditionally existed between 4P and 2P servers, 4-socket Gen10 servers still offer distinct performance and economic advantages over their 2P counterparts in some configurations. As data volumes and the need for scalability continue to grow, businesses that require 2P technology today will likely expand to 3 or 4 sockets in the foreseeable future. Purchasing HPE ProLiant 500 series Gen10 servers provides a foundation for incremental expansion and investment protection over time.

Specifically for the 2U form factor, the HPE ProLiant DL560 Gen10 Server provides flexibility to scale up processors from 2 to 4 depending upon need, and provides customers with an expandability cushion. With four processors in the system, the DL560 is capable of having twice the memory footprint of HPE ProLiant 2P servers, for a maximum memory of up to 6 TB (using 128 GB LRDIMMs) in the same 2U form factor.

## Gen10 versus Gen9 technology

Key differences exist both in the server design and innovations supported when moving from Gen9 to Gen10. Together they combine to provide enhanced security, agility, and control—driving infrastructure modernization and accelerating business insights across on-premises and off-premises IT.

### Standardizing on a single processor family for Gen10

In Gen9, the portfolio from Intel supporting 4P servers consisted of E5-4600, E7-8800, and E7-4800 processors, which included varying pricing, features, etc. With the introduction of Intel Xeon Scalable Processors, customers gain enhanced throughput and core count. Customers can now scale from 4 to 112 cores with Gen10 technology. And having a single family of processors across all Gen10 compute makes the leap to scale much easier.

### Greater storage capacity and choice

Gen10 adds storage flexibility into the design by supporting SAS, SATA, SSD, and NVMe drives. The HPE ProLiant DL560 Gen10 Server will support up to 24 SFF drives, which is similar to Gen9. The number of SFF drives in the HPE ProLiant DL580 increases from 10 to 48—which is 4.8X larger than Gen9. NVMe support grows from 6 to 12 with the HPE ProLiant DL560 Gen10 Server, and from 5 to 20 with the DL580. Support for M.2 form factor drives can also be added with an enablement kit.

### Sweet spot memory footprint at faster speeds

The industry has moved to DDR4 memory at 2666 MT/s and both the Gen10 HPE ProLiant DL560 and DL580 servers will support up to 48 DIMM slots. For the HPE ProLiant DL560 Gen10 Server, this is not a change; but for the HPE ProLiant DL580 Gen10, this cuts the maximum memory count in half. While Gen10 addresses the “sweet spot,” enabling low-to-mid memory configurations, if you need a very high DIMM count, the DL580 Gen9 server might be a better fit. HPE is also adding new technology called Fast Fault Tolerance into our next generation of memory, which is explained in detail below.

For a higher memory footprint—larger than 768 MB per processor—Intel M series processors must be ordered. This needs to be considered while purchasing processors, especially if you plan on expanding DIMMs in the future.

### Increase in I/O capacity

DL560 Gen10 has moved to flex slot power supply units (PSUs), which are smaller than common slot PSUs and consume less space, which enables up to 8 PCIe slots (with 2 PSUs).

DL580 Gen10 now uses risers for I/O slots and, with this change, it can support 16 PCIe slots including 4 FL/FH slots, ideal for double-wide GPUs. The support for four double-wide GPUs makes the DL580 an ideal platform for graphics-intensive workloads. One advantage of using the DL580 Gen10 PCIe slots is that DL580 directly connects processors 3 and 4 to PCIe slots so that there is no I/O latency or hopping through processors 1 and 2. There is more total bandwidth to move I/O with 4 processors in a DL580 compared to a DL560 Gen10.

### Enhanced security and HPE innovations in Gen10

HPE builds security into the complete compute lifecycle while also delivering critical innovations in firmware protection, malware detection, and firmware recovery. Beginning with the **silicon root of trust**, HPE anchors essential firmware directly into the silicon to add protection throughout the supply chain. **Runtime firmware verification** regularly verifies the validity and credibility of essential system firmware, while **secure recovery** capabilities return firmware to the last good known state or factory settings. Many of these security features and more are managed through [HPE iLO Advanced Premium Security Edition](#).



Gen10 enhancements safeguard the networking plane with advanced technologies such as the **root of trust, authenticated updates, secure boot, device-level firewall, audit logs, and Secure User Data Erase.**

On the storage side, **digitally signed firmware** helps protect against malicious attacks while providing assurance that drive firmware comes from a trusted source.

**Intelligent System Tuning** in Gen10 servers offers access to a new set of revolutionary capabilities—including **Jitter Smoothing, Core Boosting,**<sup>2</sup> and **Workload Matching**—that let you dynamically tune and optimize processor performance to uniquely match workload requirements.

Support for up to 24 16 GB NVDIMMs is new for both HPE ProLiant DL560 and DL580 servers in Gen10. This enhancement helps improve the performance for large database applications.

## HPE Secure Compute Lifecycle

HPE has answered the need to deliver an end-to-end security solution that addresses protection at every stage in the product's lifecycle (Figure 4). Beginning with stage one at the very inception of the product with our silicon root of trust, the server's essential firmware (iLO 5, UEFI, CPLD, IE, and ME) is loaded into our custom silicon with an unbreakable link that anchors it into the hardware. That immutable connection between the silicon and firmware protects the server through the production process, supply chain shipping, and distribution—all the way to your final location.

Once the server arrives safely at your location, the HPE Secure Compute Lifecycle continues to provide not only protection during operation but also unparalleled detection and recovery capabilities. As soon as the server is booted and the iLO firmware becomes active, our silicon root of trust looks for the immutable fingerprint that verifies all firmware code is valid and uncompromised. Before the operating system even starts, over a million lines of firmware code run, making it critical to confirm that all server-essential firmware is free from malware or compromised code.

HPE has introduced a new technology—Runtime Firmware Verification—which checks the firmware stored in the server operation. At any point, if compromised code or malware is inserted in any of the critical firmware, an iLO audit log alert is created to notify you that a compromise has occurred. A firmware breach is highly unlikely, of course. Nevertheless, a disgruntled employee with access to the data center could insert bad code. A new HPE license called HPE iLO Advanced Premium Security Edition can detect such an event and allow you to securely recover the firmware automatically to a previous known good state.

Stage three in the lifecycle process is security to and through the network. Aruba ClearPass creates a strong networking security clearance protocol for clearing anyone requesting access to the network. ClearPass creates a profile of potential users and clears access of users into our Aruba networks. Niara, a subsidiary of HPE, will be responsible for monitoring activity of users inside the network. Once ClearPass vets and clears users into networks, Niara takes over and, using machine learning, works to predict nefarious behavior before any serious damage can be done. If Niara identifies abnormal activity resembling potential malicious behavior, it communicates to ClearPass, temporarily terminating the suspected user's access to the network until more thorough vetting can be conducted. In the case of a rogue employee, this predictive capability can block potential bad actors from the network, before any damage is done.

<sup>2</sup> Core boosting on the DL500 series is available on select Intel SKUs and will be available in December 2017 (2H2017)



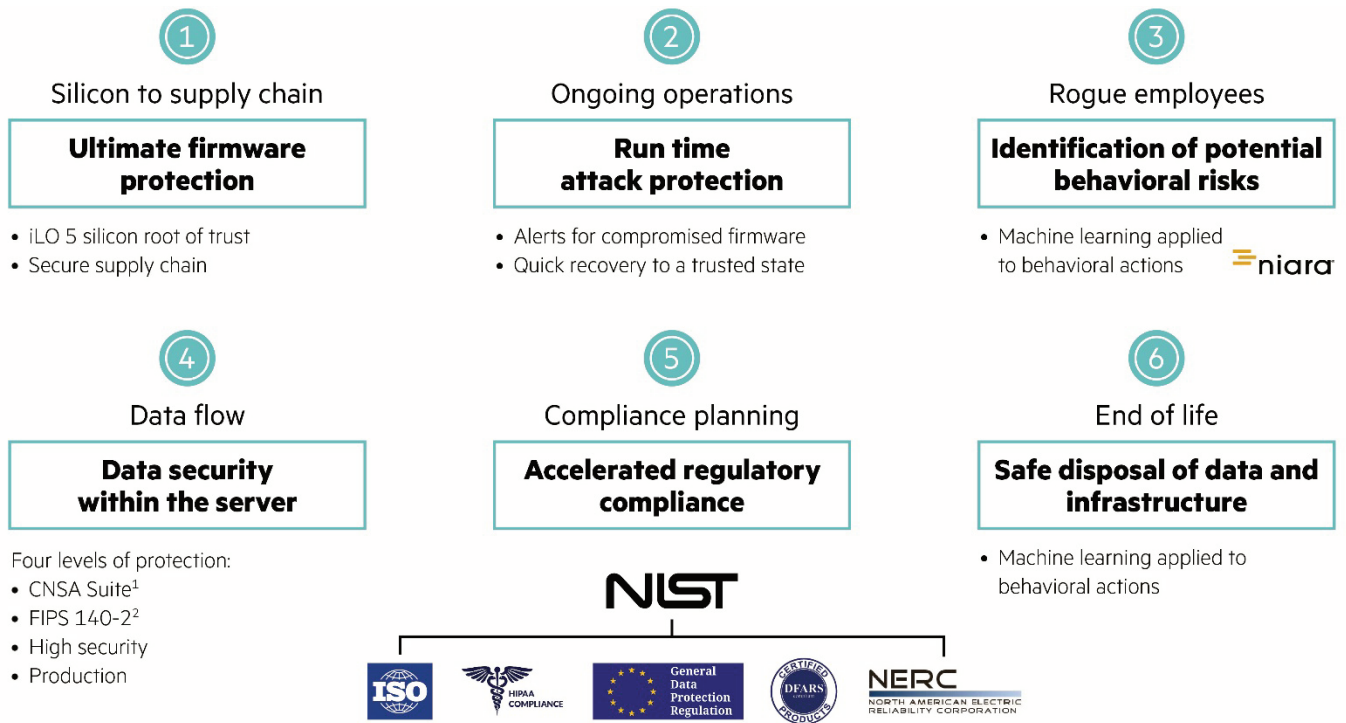

<sup>1</sup> Commercial National Security Algorithm Suite  
<sup>2</sup> Federal Information Processing Standards

Figure 4. HPE Secure Compute Lifecycle stages

The next stage (four) is protecting data and communication to and from the server and inside the server. HPE is the first industry server manufacturer to provide support for the commercial national security algorithms, or CNSA suite. This is the very highest level of security, typically used for the most confidential and top-secret information. HPE also has FIPS validation on firmware, and offers that as another level of protection during the operation phase of the server’s life.

Scalable encryption is another differentiation offering from HPE, protecting data stored in the server. Unlike competitor servers that use self-encrypting drives, requiring management of separate keys in each and every drive, HPE offers secure encryption through our smart array controller cards that contain all encryption keys and manage those at scale. Going one step further, the HPE Atalla Enterprise Secure Key Manager (ESKM) is also qualified with our controller cards that takes key management to a higher level. Through this technology, we save you the agony of tracking—sometimes on spreadsheets—an unmanageable number of encryption keys.

Closely related to security are the numerous government regulations that businesses must comply with. HPE is applying the NIST Special Publication 800-53 security controls to a solution stack of storage, networking, servers, and software, creating a secure baseline. This secure baseline is an important necessary step to issue an authority to operate (ATO) before putting IT infrastructure into operation. Additionally, this NIST 800-53 control set can assist you with certifications like FedRAMP, HIPAA, and ISO 207001. Just recently, the president issued an executive order mandating all federal agencies follow NIST guidelines for cybersecurity protections. The private sector is also beginning to use the same NIST controls as standards for preventing cybercrime.

The final stage (six) of the HPE Secure Compute Lifecycle comes after the servers and other equipment have reached their full use and entered end of life. HPE Pointnext security and protection services provide final disposal of equipment, ensuring the data is properly disposed of according to NIST standards.





## Processor technologies

HPE ProLiant Gen10 4-socket rack servers now feature the Intel Xeon Scalable Processor Family. Based on a new foundation for scalability, the Intel Xeon Scalable Processor Family is designed to seamlessly address a wide range of key workloads by delivering boosts in performance, efficiency, and security. These new technologies include the following features:

- Increased processor cores (to a maximum of 28 cores)
- Supports 2666 MT/s DDR4 memory
- Six channels per processor with two DIMMs per channel
- Three processor categories are utilized on HPE ProLiant Gen10 500 series servers:
  - Platinum (8100 series) for ERP, in-memory analytics, OLAP, HFT, virtualization, containers
  - Gold (6100/5100 series) for OLTP, analytics, AI, Hadoop/SPARK workloads, server-side Java, VDI, HPC, virtualization, containers

These enhancements allow the HPE ProLiant DL560 Gen10 4-socket server to deliver up to a 68% increase in performance<sup>3</sup> and a 27% increase in cores<sup>4</sup> from the previous generation of processors. The HPE ProLiant DL580 Gen10 4-socket server delivers up to a 28% increase in performance<sup>5</sup> and a 17% increase in cores<sup>6</sup> from the previous generation of processors.

## Intelligent System Tuning

Through a partnership with Intel, HPE offers [Intelligent System Tuning \(IST\)](#), a new set of server tuning technologies that enable you to dynamically configure server resources to match specific workloads. IST produces significant performance improvements, real savings, and a more intelligent server environment.



Figure 5. HPE Intelligent System Tuning

### Workload Matching

Workload Matching allows you to select from preconfigured workload profiles to automatically tune internal server resources to experience up to a 9% performance improvement over server default settings.<sup>7</sup> Workload Matching is available on all ProLiant Gen10 servers with iLO 5.

<sup>3</sup> Up to 68% performance increase of Intel Xeon Platinum vs. previous generation E5-4600 v4 average performance based on generational gains on HPE servers comparing 4-socket Intel Xeon Platinum 8180 to E5-4699 v4 family processors. Any difference in system hardware or software design or configuration may affect actual performance. May 2017.

<sup>4</sup> Up to 27% performance increase of Intel Xeon Platinum vs. previous generation comparing 4-socket Intel Xeon Platinum 8180 (28 cores) to E5-4669 v4 (22 cores). Calculation 28 cores/22 cores = 1.27 = 27%. May 2017.

<sup>5</sup> Up to 28% performance increase of Intel Xeon Platinum vs. previous generation E7-8800 v4 average performance based on generational gains on HPE servers comparing 4-socket Intel Xeon Platinum 8180 to E7-8890 v4 family processors. Any difference in system hardware or software design or configuration may affect actual performance. May 2017.

<sup>6</sup> Up to 17% performance increase of Intel Xeon Platinum vs. previous generation comparing 4-socket Intel Xeon Platinum 8180 (28 cores) to E7-8890 v4 (24 cores). Calculation 28 cores/24 cores = 1.167 = 17%. August 2017.

<sup>7</sup> HPE Internal testing from Performance Engineering Benchmarking team, April 2017.



## Jitter Smoothing

Engaging processor turbo boost can cause frequency fluctuations or “jitter” that results in a constant struggle between maximum output and deterministic performance needs. HPE’s Jitter Smoothing technology mitigates processor frequency fluctuation to reduce latency and deliver deterministic and reliable performance. In variable workloads where processor frequency changes occur often, Jitter Smoothing can improve overall throughput above turbo boost mode alone.<sup>8</sup> Jitter Smoothing is ideal for high-frequency traders, high-performance computing, and workloads where low processor latency and deterministic processing response is important. Jitter Smoothing is available on all Intel-based Gen10 servers with iLO 5 and an iLO Advanced (or above) license.

## Core Boosting<sup>9</sup>

Core Boosting enables higher processor frequencies on more active cores than standard Intel processor profiles, allowing you to utilize fewer processors while improving workload performance with HPE Core Boosting technology. Higher performance across fewer processors can result in significant savings when it comes to core-based licensing. In some cases, customers with core-based licensing like Oracle can experience up to \$100K in annual savings or \$500K over 5 years.<sup>10</sup> Core Boosting is ideal for virtualized environments, Big Data workloads, core-based licensing applications, and workloads where performance is a competitive advantage. Core boosting will be available with select Intel processors on the DL500 platforms.

## Memory technologies

IT trends such as server virtualization, cloud computing, high-performance computing, and other resource-intensive applications continue to place increasing demands on the requirements for server memory in terms of speed, capacity, and availability. These demands define the system’s reliability, performance, and overall power consumption to a much greater extent than before—making server memory a critical component in meeting your IT solution requirements.

HPE ProLiant Gen10 servers feature HPE DDR4 SmartMemory that supports faster memory speeds than before. HPE also offers standard memory—designed to provide reliable memory performance for use in less demanding environments. In addition, HPE offers Persistent Memory using HPE NVDIMMs. And finally, HPE Advanced Memory Error Detection Technology, including Fast Fault Tolerance, delivers enhanced reliability and memory protection on ProLiant Gen10 servers.

### HPE DDR4 SmartMemory

HPE DDR4 SmartMemory offers significant improvements over previous memory generations. Unlike third-party memory, HPE SmartMemory is authenticated by the server to verify that memory has passed HPE’s rigorous qualification and testing, ensuring you are using the highest quality server memory.

For the HPE Gen10 ProLiant servers using the Intel Xeon Scalable Processor Family, HPE DDR4 SmartMemory is now capable of operating at 2666 MT/s, delivering a 12.5% increase in maximum throughput over earlier DDR4 memory and a 29% increase over the last generation of DDR3 memory.<sup>11</sup> For applications that require maximum memory capacity, HPE SmartMemory Load Reduced DIMMs (LRDIMMs) reduce the electrical load to the memory controller, allowing higher capacity memory to run at maximum speed in all configurations.

HPE SmartMemory also provides the following benefits over third-party memory when used in ProLiant Gen10 servers:

- Extended performance: In two DPC configurations, HPE SmartMemory operates at a higher transfer rate than industry standard DDR4 DIMMs, delivering better memory performance.
- Enhanced manageability: HPE SmartMemory integrates with HPE Active Health System for enhanced monitoring, reporting, and problem diagnosis.

Memory DIMM availability for specific server platforms is dependent upon completion of certification testing.

<sup>8</sup> HPE Internal testing from Performance Engineering Benchmarking team, April 2017.

<sup>9</sup> Core boosting on the DL500 series is available on select Intel SKUs and will be available in December 2017 (2H2017).

<sup>10</sup> HPE Internal testing from Performance Engineering Benchmarking team, April 2017; Reducing costs in your Oracle database environment [hpe.com/us/en/resources/servers/oracle-database.html](http://hpe.com/us/en/resources/servers/oracle-database.html)

<sup>11</sup> HPE Internal testing from Performance Engineering Benchmarking team, April 2017.



## HPE Advanced Memory Error Detection Technology

Uncorrectable memory errors can cause applications and operating systems to crash, so they are costly in terms of downtime and repairs. The best way to prevent unnecessary DIMM replacement is to filter out superfluous errors and identify critical errors that can lead to a shutdown. You can no longer rely on simple error event counts on systems containing up to 14 trillion memory transistors. With HPE Advanced Memory Error Detection Technology, we reinvented a precision system to pinpoint errors that cause downtime.

HPE Advanced Memory Error Detection Technology seeks out specific defects that either cause performance degradation or significantly increase the probability of an uncorrectable (non-recoverable) memory condition. By improving the prediction of non-recoverable memory events, this technology prevents unnecessary DIMM replacements and increases server uptime.

The latest addition to the suite of HPE error detection technologies is Fast Fault Tolerance, which enables a server to boot with full memory performance while monitoring for DRAM device failures. In the event of a memory failure, the memory subsystem automatically reorganizes the way data is stored in memory to create a protected region just large enough to correct the DRAM failure, while allowing the remaining portions of memory to continue to run at full performance.

## HPE Persistent Memory

HPE Persistent Memory technology is designed to deliver the performance of memory with the persistence of traditional storage. HPE has the broadest persistent memory portfolio in the market and offers high performing NVDIMMs.

HPE 16 GB NVDIMMs are the first NVDIMMs in the HPE Persistent Memory category. These NVDIMMs are installed in the same memory slots as standard DDR4 DIMMs and feature DRAM memory for workload performance backed by NAND flash for persistence. In the event of a power down, the HPE Smart Storage Battery holds up the power on the memory slots so any data residing on DRAM can be moved to NAND flash.

Although HPE NVDIMMs share memory slots with HPE SmartMemory, they are not used as system memory. The HPE NVDIMMs are the fastest tier of storage in ProLiant servers and primarily used for application acceleration and caching use cases. Operating system drivers are required for NVDIMMs, and today's applications address this technology as a block storage device—just like applications access traditional storage devices such as HDDs and SSDs. HPE Persistent Memory is capable of delivering data performance with nanosecond latencies compared to latencies in the hundreds of microseconds for other fast storage devices such as HPE PCIe Workload Accelerators.

## HPE NVDIMMs

HPE NVDIMMs offer up to 73X lower latency, 24X more I/Os per second (IOPS), and 6X greater bandwidth compared to the HPE PCIe Workload Accelerators.<sup>12</sup> HPE NVDIMMs on HPE ProLiant 500 series Gen10 servers offer twice the capacity of first generation HPE NVDIMMs.<sup>13</sup> With Microsoft® SQL Server, HPE lab testing has demonstrated up to 4X faster performance relative to using SSDs alone. And using NVDIMMs with fewer server core pairs can also reduce software licensing by up to 50%.

## HPE server storage

The IT landscape has changed. The amount of data you have to manage and analyze has grown at an unprecedented rate with no end in sight. As data storage requirements grow, you need solutions that can help overcome performance bottlenecks caused by demanding application workloads. Today's storage solutions should:

- Keep pace with data growth
- Enable fast access to data to keep you competitive
- Protect data integrity from outages and data loss
- Perform reliably to maximize uptime

<sup>12</sup> HPE Internal testing from Performance Engineering Benchmarking team, April 2017.

<sup>13</sup> Comparing 8 GB NVDIMM to 16 GB NVDIMM equals 2X capacity increase, June 2017.



HPE offers a broad portfolio of workload-optimized solutions for every server storage need. Our offerings provide enterprise environments a combination of the latest technologies to enable hassle-free performance, proven reliability, and security, backed by more than 3.35 million hours<sup>14</sup> of the industry's most rigorous testing and qualification program. Our drives feature HPE Digitally Signed Firmware, which prevents data loss and malicious attacks by assuring that drive firmware comes from a trusted source.

### **HPE HDDs**

HPE HDDs deliver proven performance and reliable data integrity at the lowest cost per gigabyte. Most drives feature the HPE SMART Carrier with intuitive icons to report drive activity at-a-glance and a “do not remove” button that prevents data loss caused by human error.

### **HPE SSDs**

HPE SSDs remove performance bottlenecks, enabling faster access to data with consistently low latency—all while using less power. These drives are best suited for enterprise environments where highly random data is accessed by a variety of write-workload applications such as online transaction processing or Big Data analytics. HPE SSDs offer improved random read and write input/output operations per second (IOPS) and are available in both SAS and SATA to fit your needs.

### **HPE NVMe PCIe SSDs**

HPE NVMe PCIe SSDs utilize the NVMe interface to talk directly to your applications via the PCIe bus. By hosting your entire database on one or more HPE NVMe PCIe SSDs, you boost I/O performance, leverage in-memory access, reduce latency, and scale performance in-line with your processing requirements. These features create a flexible and dependable solution to proactively address your storage needs. HPE ProLiant 500 series Gen10 servers offer 2X to 4X more NVMe drives, enabling direct connect performance.<sup>15</sup> HPE NVMe PCIe SSDs are available in 2.5-in, add-in cards (AIC) and M.2 form factors.

### **HPE M.2 and M.2 Enablement Kit SSDs**

As the most recent addition to our read-intensive SSD family, HPE M.2 SSDs are best suitable for boot/swap. This flexible form factor saves hot pluggable bays for removable SSDs.

### **HPE Smart Array Controllers**

HPE Smart Array Gen10 Controllers Smart Array Gen10 Controllers deliver up to 65% more performance with up to 1.6M IOPS<sup>16</sup> while using up to 45% less power<sup>17</sup> compared to previous generation controllers. Additionally, you get enterprise-class data-at-rest encryption to help you comply with regulations like HIPAA and Sarbanes-Oxley. New for Gen10 servers, mixed mode allows you to use both HBA and RAID modes simultaneously on one controller, freeing up a PCIe slot for other uses, for additional flexibility. You can choose from Smart Array S-Class software RAID, and Smart Array E-Class or P-Class controllers—each delivering a broad feature set and related benefits.

### **HPE Universal Media Bay**

The HPE Universal Media Bay adds functional flexibility to HPE ProLiant DL580 Gen10 and DL560 Gen10 Servers. Universal Media Bay kits allow you to customize your server's configuration by adding, depending on platform, an optical disk drive bay, USB ports, 2 x Dual uFF with M.2 cartridges, and/or a display port. The kit installs in a specific box of the server.

### **Networking for HPE Gen10 4-socket servers**

For ProLiant Gen10 servers, HPE provides the next generation networking adapters designed to meet the needs of converged IT infrastructure with higher performance and support for key Ethernet features. Gen10 servers utilize the new dual- and quad-port stand-up NICs at speeds up to 25 Gb/s. The HPE ProLiant DL580 and DL560 Gen10 Servers can also use the HPE FlexibleLOM adapters that provide speeds up to 40 Gb/s.

<sup>14</sup> Derived from a combination of drive qualification test plans, specifically HDDQ spec-supplier responsibility to perform, RDT-Reliability Demonstration test spec, CSI integration test spec, and Pilot test requirements. Test conducted May 2017.

<sup>15</sup> Up to 5 NVMe drives in DL580 Gen9 and up to 20 NVMe drives in DL580 Gen10, 20/5 = 4. September 2017.

<sup>16</sup> HPE Internal lab testing comparing HPE Gen9 to Gen10 Smart Array Controllers, January 2017.

<sup>17</sup> HPE Internal lab testing comparing HPE Gen9 to Gen10 Smart Array Controllers, May 2017.



Gen10 networking adapters also feature several capabilities such as NIC Partitioning (NPAR), Data Plane Development Kit (DPDK), Tunnel Offload (NVGRE/VXLAN), and RDMA over Converged Ethernet (RoCE) that deliver improved network performance and efficiency in specific environments.

Gen10 networking adapters come with security features that help protect, detect, and recover from malicious attacks to the firmware. It all starts with digitally signing the firmware. HPE sends firmware and security requirements to the adapter manufacturer, who then creates a public and private key pair through a secure code signing process. The public key is embedded in the NIC silicon. The network adapter's "Chain of Trust" is created from a true hardware root of trust. Firmware encrypted with a private key must be decrypted by the public key in the NIC silicon in order to be validated. In addition to root of trust, HPE's adapters offer additional key security features such as UEFI Secure Boot, authenticated updates, audit logs, device-level firewall, and sanitization.

LAN-on-motherboard (LOM) technology provides essential network connectivity without requiring a network card to be installed in an expansion slot. While standard LOM design leaves expansion slots available for expansion functions, it also limits your connectivity options. We developed FlexibleLOM technology, which uses a FlexibleLOM module that attaches to a dedicated edge connector on the system board. FlexibleLOM technology maintains the close-coupled interface of a LOM while allowing you to select the connectivity you need now—and adapt to network changes in the future without using a standard PCIe slot.

## Power efficiency and provisioning

We have designed power supplies with industry-leading efficiency ratings and have developed technologies that allow you to precisely monitor and control HPE ProLiant Gen10 servers' energy use.

### HPE Flexible Slot Power Supply

HPE ProLiant DL560 and DL580 Gen10 Servers feature HPE Flexible Slot (Flex Slot) Power Supply Unit (PSU) bays that accommodate HPE Flex Slot PSUs. The HPE Flex Slot design represents a new generation of tool-less, hot-swappable components that use the cross-platform interchangeability model introduced with our common slot power supplies. For detailed information about Flex Slot PSUs, refer to the white paper HPE Flexible Slot Power Supply Unit.

HPE Flex Slot PSUs achieve the same degree of efficiency as common slot power supplies but use 25% less space, thus allowing more room for compute and I/O connectivity functions in the server chassis. HPE Flex Slot PSUs are 80 Plus certified and offer from 94% to 96% efficiencies. They are available in 800W and 1600W models for 100 (200)–240 VAC input power.

### HPE 3D Sea of Sensors

HPE 3D Sea of Sensors provides the data to precisely control the server fans and directly cool specific components while not overcooling other components. This significantly reduces fan power consumption per server. HPE Sea of Sensors extends the use of sensors to select PCI Express option cards and FlexibleLOM adapters to get a three-dimensional temperature profile in the server. This additional data enables more precise and efficient cooling of HPE ProLiant Gen10 servers. The data is included in the always-on diagnostic information of the HPE Active Health System.

## Power provisioning tools

HPE Power Provisioning tools include Dynamic Power Capping and Power Regulator for ProLiant. These tools, summarized below, help administrators maximize data center power usage by fitting more IT equipment in the available power and cooling capacity.

### HPE Power Regulator for ProLiant

HPE Power Regulator for ProLiant is a hardware feature that enables ProLiant servers to dynamically control performance states (p-states) of the system processors. HPE Power Regulator features Dynamic Power Capping, sophisticated monitoring, and control circuitry that prevents server power from exceeding a preset level. Because Dynamic Power Capping is hardware-based, it can quickly control sudden surges in power consumption by servers and prevent tripping even the fastest circuit breakers used in HPE Power Distribution Units (PDUs). You can set a power cap for an individual server from the HPE Integrated Lights Out (iLO) user interface. For groups of servers, you can set the power caps from the power management module with iLO Federation Group Power Capping within HPE iLO. HPE iLO functionality of Group Power Capping requires an iLO Advanced or iLO Scale-Out license.



### Compliance with ASHRAE expanded operating ranges<sup>18</sup>

ASHRAE establishes temperature and humidity guidelines for data center operation. HPE ProLiant Gen10 4-socket servers will meet ASHRAE ambient temperature operating classes A3 and A4, which define maximum allowable ambient temperatures of 40°C and 45°C, respectively. These extended operating ranges may allow you to raise your data centers' operating temperature and/or use more efficient cooling strategies in your facility, significantly reducing energy consumption.

### Managing HPE ProLiant Gen10 servers

HPE offers a set of server management capabilities that give you complete control of your IT infrastructure. For Gen10 servers, we have introduced a number of management innovations for HPE ProLiant servers, all working together to give you complete control of the monitoring and management of the servers and infrastructure in your data center.

### Embedded management with HPE iLO 5

HPE iLO allows you to configure, monitor, and update your HPE servers seamlessly from anywhere in the world. Featuring the latest innovations in simplified operations, performance, and security, HPE iLO allows you to manage your entire server environment with ease. For HPE ProLiant Gen10 servers, iLO 5 provides several new improvements in security, speed, and simplicity (some features require an optional iLO Advanced or iLO Advanced Premium Security Edition license).

- **Security:**

- **Protect:** HPE Secure Start uniquely ensures that only HPE-signed firmware will boot by validating through HPE's silicon root of trust, so you can be confident that the server's essential firmware stack (UEFI BIOS, iLO, and so on) is safe. New secure access controls like Commercial National Security Algorithm (CNSA) and Common Access Card (CAC 2) factor authentication are also available with iLO 5.
- **Detect:** Runtime firmware verification is a new feature in iLO 5 that ensures your firmware is checked at regular intervals to identify any potential intrusions that may occur post-boot.
- **Recover:** Avoid lasting damage to your business by quickly restoring firmware to the factory settings or the last known authenticated safe setting in the unlikely event of a breach with automatic and manual firmware recovery capabilities.

- **Speed:**

- **iLO 5 speed:** With 2X the CPU MHz in iLO 5, virtual media performance is twice as fast vs iLO 4.<sup>19</sup>
- **iLO service port:** Available on Gen10 servers, the new iLO service port is a USB port for integrated remote console and active health system (AHS) downloads that gives you direct, front of server access to iLO. This new feature also allows you to give iLO access without the need to connect and authenticate on your network, making it simpler to access the information you need quickly.

- **Simplicity:**

- **Agentless management:** With iLO 5, we're moving to full agentless management. Freedom from the hassle of inventorying and updating various management agents, agentless management allows for a more simplified and streamlined way to monitor your servers.
- **IPMI:** Gen10 enhancements allow for increased interoperability with industry Intelligent Platform Management Interface (IPMI) tools.

### Converged management using HPE OneView

[HPE OneView](#) is an infrastructure automation engine built with software-defined intelligence and a template-based approach to management that makes Hybrid IT simple. HPE OneView provides faster and simpler lifecycle operations across compute, storage, and fabric resources. Productivity is increased via a unified API that connects infrastructure with applications and places you firmly on the path toward composable infrastructure.

HPE OneView continues to evolve and grow, with HPE OneView v3.1, incorporating the following new features:

<sup>18</sup> Compliance to be met 2H2017.

<sup>19</sup> iLO 5 has double the CPU MHz as iLO 4. iLO 5 Virtual Media is 1.9964X faster than iLO 4. Comparison: DL360 Gen10 about 5 MB+/s (catch point 5.53 MB/s) (note: encrypted) vs. DL360 Gen9 about 2.5 MB+/s (catch point 2.77 MB/s) (note: not encrypted), April, 2017.



- **Common approach to storage management**—Simplifies provisioning of storage volumes and removes inefficiencies with support for HPE's leading composable, software-defined StoreVirtual VSA storage.
- **Extended platform support**—Gives you the ability to easily manage HPE platforms with one comprehensive management tool. HPE OneView now provides support for HPE Synergy; ProLiant BL, DL, and ML; HPE Apollo; and HPE Superdome X servers.
- **Simplified firmware management**—Enables updates to occur faster and easier with minimal disruption to production workloads.
- **Enhanced remote support**—Allows planning service contracts more efficiently. Contract and warranty display is available for each device, so you can easily see in advance what is going to be out of contract and warranty.
- **Global dashboard**—Extends functionality to even more HPE platforms, adding support for up to 12,800 servers and 20 HPE OneView appliances. Also added is the ability to backup and restore the global dashboard in the event of a disaster and easy access to data using customized reports with built-in filtering, sorting, and saving.
- **New HPE Composable Ecosystem additions**—Offer more choices to take advantage of the unified API to automate their solutions. The latest include: Mesosphere for provisioning and extending clusters, ServiceNow for improving service levels with immediate event visibility, Densify.com by Cirba for intelligent capacity optimization, and Red Hat® OpenShift for bare-metal containers as a service.

HPE continues to offer HPE Systems Insight Manager (SIM) to manage Gen10 servers within your data center. Note, however, that our strategic management platform for our next generation platforms is HPE OneView.

## HPE Pointnext

[HPE Pointnext](#) leverages our strength in infrastructure, partner ecosystems, and end-to-end lifecycle support to offer you powerful, scalable IT solutions for faster time to value. HPE Pointnext provides a comprehensive portfolio including advisory and transformational, professional, and operational services to accelerate your digital transformation.

HPE Pointnext services include:

- **Flexible Capacity:** An infrastructure service that offers on-demand capacity, combining the agility and economics of public cloud with the security and performance of on-premises IT.
- **Datacenter Care:** HPE's most comprehensive support solution tailored to meet your specific data center support requirements. It offers a wide choice of proactive and reactive service levels to cover requirements ranging from the most basic to the most business-critical environments. HPE Datacenter Care Service is designed to scale to any size and type of data center environment while providing a single point of contact for all your support needs for HPE as well as selected multivendor products.
- **Proactive Care:** An integrated set of reactive and proactive services designed to help you improve the stability and operation of your device.
- **Foundation Care:** Support for HPE servers, storage, networking hardware and software to meet your availability requirements with a variety of coverage levels and response times.
- **Advisory and Transformation Services:** Designs the transformation and builds a road map tuned to your unique challenges including Hybrid IT, workload and application migration, Big Data, and the Intelligent Edge. HPE leverages proven architectures and blueprints, integrates HPE Enterprise Group and partner products and solutions, and engages HPE Pointnext Professional and Operational Services teams as needed.
- **Professional Services:** Creates and integrates configurations that get the most out of software and hardware, and works with your preferred technologies to deliver the optimal solution. Services provided by the HPE Pointnext team, certified channel partners, or specialist delivery partners include installation and deployment services, mission-critical and technical services, and education services.

## Conclusion

Integrating HPE's leading-edge security, memory, storage, networking, and management technologies with the latest Intel Xeon Scalable Processor Family make HPE ProLiant Gen10 4-socket servers the ideal platforms to support a range of compute needs and workloads. With the ability to reduce provisioning time from hours to seconds and offering right-sized and workload-optimized performance, HPE ProLiant Gen10 4-socket rack-mount servers lower your TCO and deliver value of service.



## Additional resources

[hpe.com/servers/dl580](http://hpe.com/servers/dl580)

[hpe.com/servers/dl560](http://hpe.com/servers/dl560)

[hpe.com/security](http://hpe.com/security)

[hpe.com/infrastructure](http://hpe.com/infrastructure)

[hpe.com/info/ist](http://hpe.com/info/ist)

[hpe.com/info/tuning](http://hpe.com/info/tuning)

[hpe.com/info/gen10](http://hpe.com/info/gen10)

Reference the [HPE ProLiant Gen10 2-socket white paper](#) for additional resources.

## Learn more at

[hpe.com/info/proliant-dl-servers](http://hpe.com/info/proliant-dl-servers)

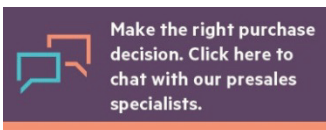

**Sign up for updates**



---

© Copyright 2017–2018 Hewlett Packard Enterprise Development LP. The information contained herein is subject to change without notice. The only warranties for Hewlett Packard Enterprise products and services are set forth in the express warranty statements accompanying such products and services. Nothing herein should be construed as constituting an additional warranty. Hewlett Packard Enterprise shall not be liable for technical or editorial errors or omissions contained herein.

Intel and Intel Xeon are trademarks of Intel Corporation in the U.S. and other countries. Microsoft is either a registered trademark or trademark of Microsoft Corporation in the United States and/or other countries. Oracle and Java are registered trademarks of Oracle and/or its affiliates. Red Hat is a registered trademark of Red Hat, Inc. in the United States and other countries. SAP is the trademark or registered trademark of SAP SE in Germany and in several other countries. Hadoop is either a registered trademark or trademark of the Apache Software Foundation in the United States and/or other countries. All other third-party trademark(s) is/are property of their respective owner(s).