

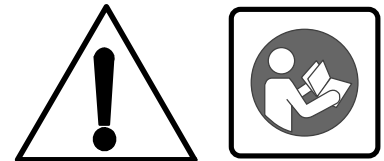

T1

Battery Floor Scrubber

Service Information Manual



Models:

9008636 - T1, AGM Battery

9008639 - T1, Lithium-ion Battery

North America / International

www.tennantco.com

9008975
Rev. 00 (06-2011)





Read this manual completely and understand the machine before operating or servicing it.

This machine will provide excellent service. However, the best results will be obtained at minimum costs if:

- The machine is operated with reasonable care according to instructions provided.
- The machine is maintained regularly - per the machine maintenance instructions provided.
- The machine is maintained with manufacturer - supplied or equivalent parts.

Use the parts manual to order replacement parts.

UNCRATING MACHINE: Carefully check carton for signs of damage. Report damages at once to carrier.



PROTECT THE ENVIRONMENT

Please dispose of packaging materials and old machine components in an environmentally safe way according to local waste disposal regulations.



Always remember to recycle.

MACHINE DATA

Please fill out at time of installation for future reference.

Model No. - _____

Serial No. - _____

Sales Rep. - _____

Sales Rep. phone no. - _____

Customer Number - _____

Installation Date - _____

Tennant Company

PO Box 1452

Minneapolis, MN 55440 USA

Tel: (800) 553-8033 ou (763) 513-2850

www.tennantco.com

Specifications and parts are subject to change without notice. Original Instructions. Copyright© 2011 Tennant Company. All rights reserved.

Contents	Page
Safety Precautions	1-1
General Information	2-1
Component Locator.....	2-2
Electrical Schematics	2-3
Symbols	2-3
Lithium-ion Battery (1 of 2).....	2-4
Lithium-ion Battery (2 of 2).....	2-5
AGM Battery (1 of 2).....	2-6
AGM Battery (2 of 2).....	2-7
Specifications	2-8
Fastener Torque.....	2-8
Machine Specifications.....	2-9
Machine Dimensions.....	2-9
Electrical Components	2-10
Maintenance	3-1
Machine Maintenance.....	3-2
After Each Use	3-2
After Weekly Use.....	3-2
Vacuum Hose.....	3-3
Squeegee Blade Replacement.....	3-4
Transporting Machine.....	3-4
Storing Machine	3-5
Troubleshooting	4-1
Battery Charger and BMS, Lithium-ion	4-2
Operation.....	4-2
Faults.....	4-2
Battery Management System (BMS).....	4-2
Battery Charger, AGM	4-3
Operation.....	4-3
Configuration.....	4-3
Displaying Current Settings.....	4-3
Checking DIP Switches	4-3
Faults.....	4-3
Subsystem Troubleshooting	4-4
Lithium-ion Battery	4-4
Charger Connected (0-5 Seconds)	4-4
Electrical Schematic.....	4-4
Troubleshooting.....	4-5
Charger Connected (5+ Seconds)	4-6
Electrical Schematic.....	4-6
Troubleshooting.....	4-7
Power Up Circuit (0-5 Seconds)	4-8
Electrical Schematic.....	4-8
Troubleshooting.....	4-9
Power Up Circuit (5+ Seconds).....	4-10
Electrical Schematic.....	4-10
Troubleshooting.....	4-11

Contents	Page
AGM Battery	4-12
Charger Connected	4-12
Electrical Schematic.....	4-12
Troubleshooting.....	4-13
Power Up Circuit	4-14
Electrical Schematic.....	4-14
Troubleshooting.....	4-15

SAFETY PRECAUTIONS

This machine is intended for commercial use. It is designed exclusively to scrub hard floors in an indoor environment and is not constructed for any other use. Use only recommended brushes and commercially approved floor cleaners intended for machine application.

All operators must read, understand and practice the following safety precautions.

The following warning alert symbol and the "FOR SAFETY" heading are used throughout this manual as indicated in their description:

 **WARNING:** To warn of hazards or unsafe practices which could result in severe personal injury or death.

FOR SAFETY: To identify actions which must be followed for safe operation of equipment.

The following safety precautions signal potentially dangerous conditions to the operator or equipment.

 **WARNING:** Fire Or Explosion Hazard

- Do Not Use or Pick Up Flammable Materials
- Only Use Commercially Available Floor Cleaners Intended for Machine Application.
- Do Not Use Near Flammable Liquids, Vapors or Combustible Dusts.
- Batteries Emit Hydrogen Gases. Keep Machine Away from Heat, Sparks and Open Flame.

This machine is not equipped with explosion proof motors. The electric motors will spark upon start up and during operation which could cause a flash fire or explosion if machine is used in an area where flammable vapors/liquids or combustible dusts are present.

 **WARNING:** Electrical Hazard

- Do Not Charge Batteries with Damaged Cord. Do Not Modify Plug.

If the charger cord is damaged or broken, it must be replaced by the manufacturer or its service agent or a similarly qualified person in order to avoid a hazard.

- Disconnect Battery Cable and Charger Cord Before Servicing.

 **WARNING:** Spinning Brush. Keep Hands Away.

 **WARNING:** Electrical Shock Hazard. Do Not Use Outdoors. Do Not Expose To Rain/Moisture. Store Indoors.

FOR SAFETY:

1. Do not operate machine:
 - Unless trained and authorized.
 - Unless operator manual is read and understood.
 - Unless mentally and physically capable of following machine instructions.
 - In an area where flammable vapors/liquids or combustible dusts are present.
 - Outdoors.
 - If not in proper operating condition.
 - If battery emits an unusual odor, Move machine to a ventilated area and contact Customer Service immediately.
 - If battery is leaking any substance, Avoid contact with battery substance and contact Customer Service immediately.
 - If battery becomes excessively hot, Disconnect battery charger. Move machine to a ventilated area and contact Customer Service immediately.
2. Before operating machine:
 - Make sure all safety devices are in place and operate properly.
 - Wear non-slip shoes.
 - Follow safety guidelines concerning wet floors.
 - Follow mixing, handling and disposal instructions on chemical containers.
3. When operating machine:
 - Report machine damage or faulty operation immediately.
 - Do not allow children to play on or around machine.
 - If foam or liquid begins to leak from machine, immediately shut off machine.
 - Do not operate on inclines.
4. Before leaving machine:
 - Stop on level surface.
 - Turn the main power switch to the off position.
5. When servicing machine:
 - Stop on level surface.
 - Turn the main power switch to the off position.
 - Do not tilt machine back unless main power switch is turned off and tanks are empty.

SAFETY PRECAUTIONS

- Disconnect battery connections before working on machine.
 - Do not disconnect the charger's DC cord from the machine's receptacle when the charger is operating. Arcing may result. If the charger must be interrupted during charging, disconnect the AC power supply cord first.
 - The use of incompatible battery chargers may damage battery and potentially cause a fire hazard.
 - Wear protective gloves and eye protection when handling batteries or battery cables.
 - Avoid contact with battery acid.
 - Use manufacturer supplied or approved replacement parts.
 - All repairs must be performed by a qualified service person.
- Avoid moving parts. Do not wear loose clothing or jewelry.
 - Do not power spray or hose off machine. Electrical malfunction may occur.
 - Do not modify the machine from its original design.
6. When transporting machine:
- Turn the main power switch to the off position.
 - Get assistance or use a mechanical lift when lifting machine.
 - Do not wheel up or down stairs.
 - Do not tilt on rear casters or wheels.
 - Use tie-down straps to secure machine when transporting by vehicle.

SAFETY LABELS

The safety labels appear on the machine in the locations indicated. Replace labels if they are missing or become damaged or illegible.



FOR SAFETY: When servicing machine, the use of incompatible battery chargers may damage battery and potentially cause a fire hazard.

SECTION 2

Contents	Page
General Information	2-1
Component Locator.....	2-2
Electrical Schematics.....	2-3
Symbols.....	2-3
Lithium-ion Battery (1 of 2).....	2-4
Lithium-ion Battery (2 of 2).....	2-5
AGM Battery (1 of 2).....	2-6
AGM Battery (2 of 2).....	2-7
Specifications.....	2-8
Fastener Torque.....	2-8
Machine Specifications.....	2-9
Machine Dimensions.....	2-9
Electrical Components.....	2-10

GENERAL INFORMATION

MACHINE COMPONENTS

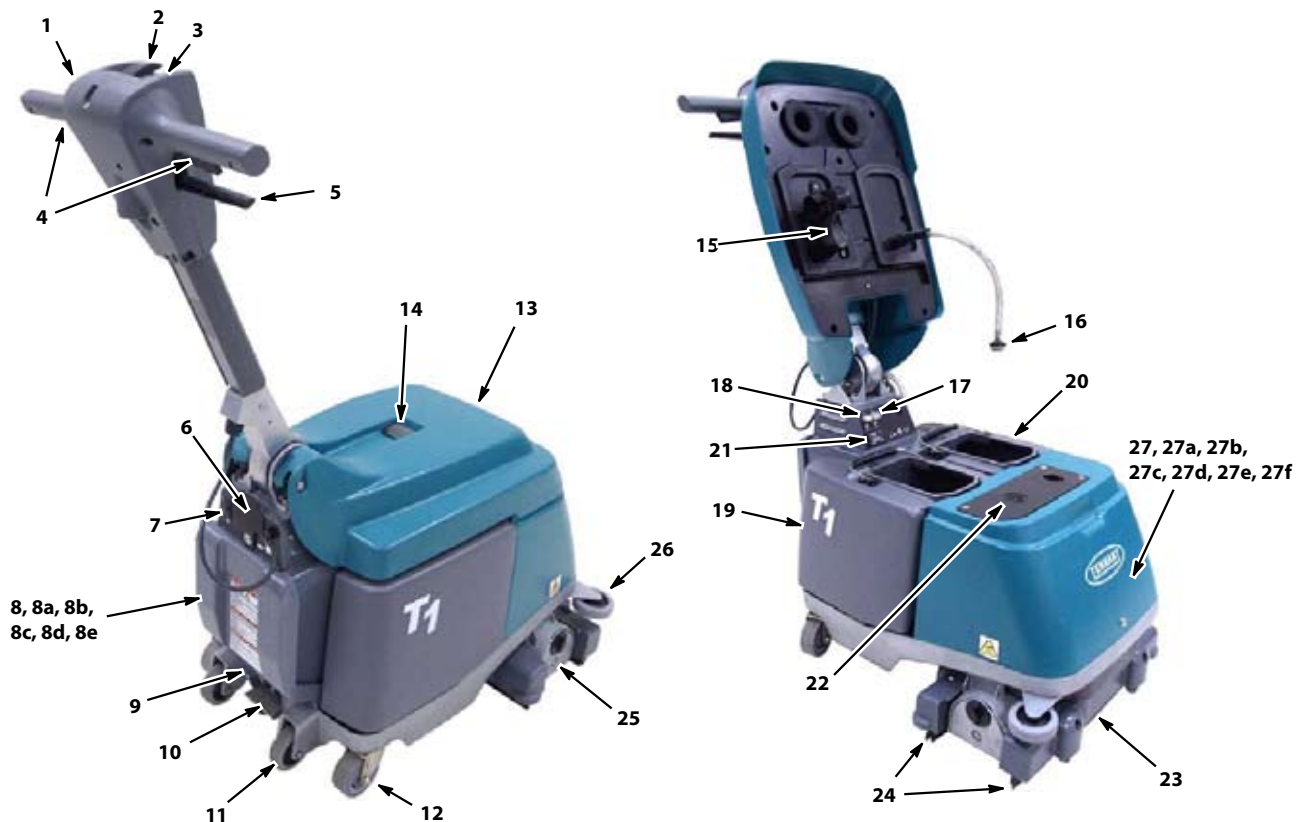

- 1. Adjustable Control Handle
- 2. Main Power ON/OFF Switch
- 3. Battery Discharge Indicator
- 4. Start Triggers
- 5. Handle Adjustment Lever
- 6. Battery Charger Connector
- 7. Vacuum Power ON/OFF Switch
- 8. Rear Access Cover
 - a. Relays
 - b. Timer
 - c. Solution Check Valve
 - d. Battery
 - e. BMS (battery management system)
- 9. Transport Release Pedal
- 10. Scrub Head Lift Pedal

- 11. Curb Climbing Wheels
- 12. Main Wheels
- 13. Tank Cover
- 14. Recovery Window
- 15. Vacuum Shut-Off Float
- 16. Solution Tank Screen
- 17. Brush Circuit Breaker Button
- 18. Vacuum Circuit Breaker Button
- 19. Recovery Tank
- 20. Solution Tank
- 21. Hour Meter
- 22. Vacuum Intake Screen
- 23. Scrub Head
- 24. Squeegee Blades
- 25. Brush Housing

- 26. Bumper Wheel
- 27. Front Access Cover
 - a. Fuses
 - b. Solution Pump
 - c. Spray Nozzles
 - d. Brush Motor
 - e. Suction Hoses
 - f. Vacuum Fan

MACHINE OPERATION SYMBOLS

Power On

Battery Discharge Indicator

Brush Circuit Breaker

Battery Charging

Power Off

Vacuum

Vacuum Circuit Breaker

2% (1 °) Maximum Grade Level

ELECTRICAL SCHEMATIC SYMBOLS

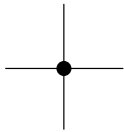

Connected



Battery

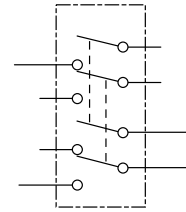

DPDT Switch

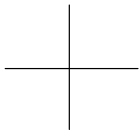

Not Connected



Fuse

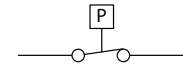

Pressure Switch

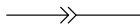

Connector



Circuit Breaker

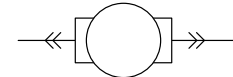

Motor



Energized



Single Continuation Tab



Resistor



Notes



Double Continuation Tab

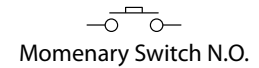

Momentary Switch N.O.



Diode

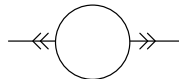

Relay Coil

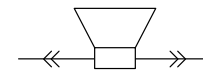

Horn or Alarm



Assembly



N.C. Relay Contacts

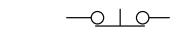

Contact Switch N.C.



AC Plug



N.O. Relay Contacts

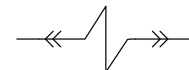

Solenoid Valve

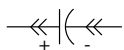

Capacitor



Light

ELECTRICAL SCHEMATIC - LITHIUM BATTERY (2 of 2)

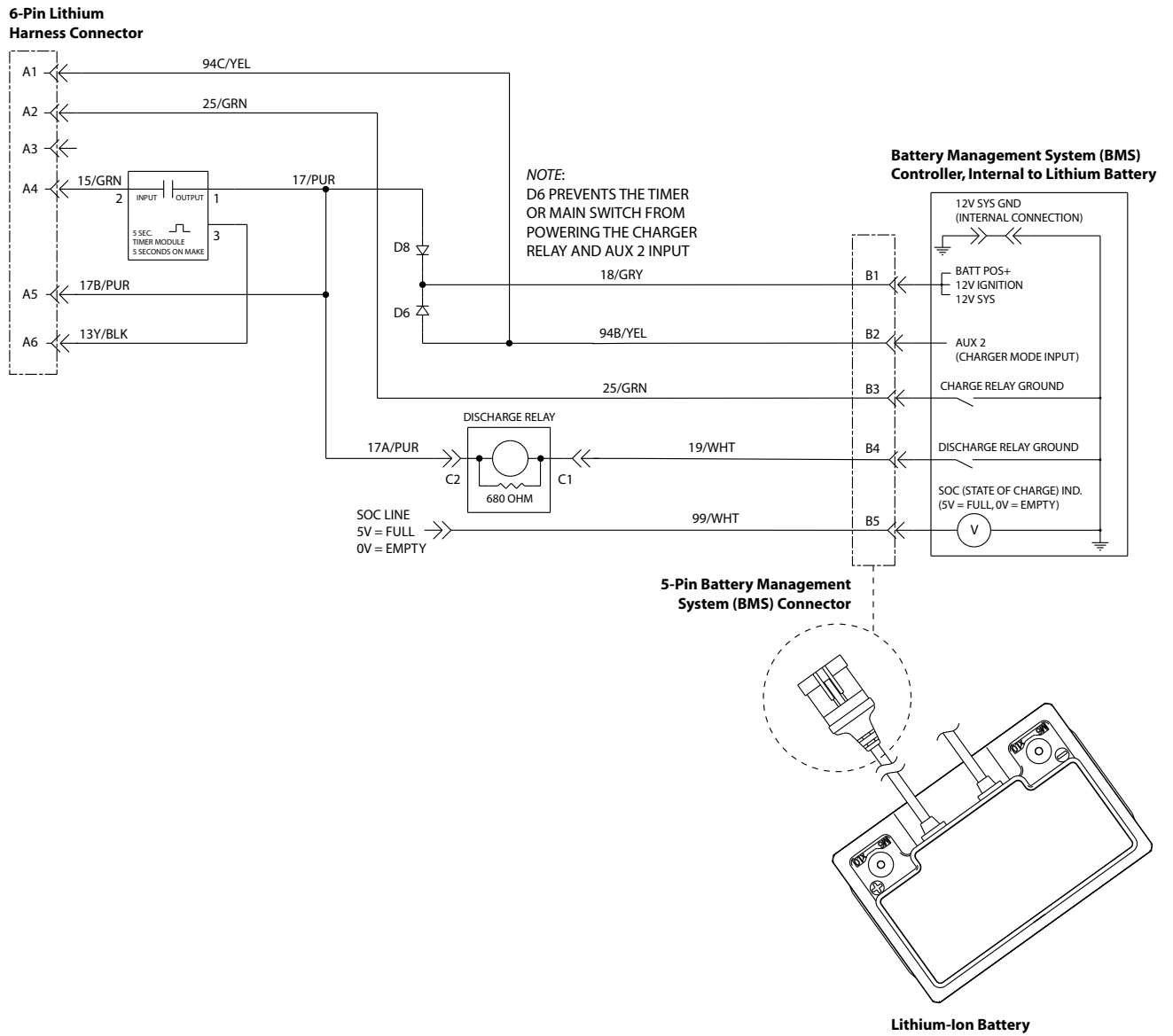

GENERAL INFORMATION

ELECTRICAL SCHEMATIC - AGM BATTERY (1 of 2)

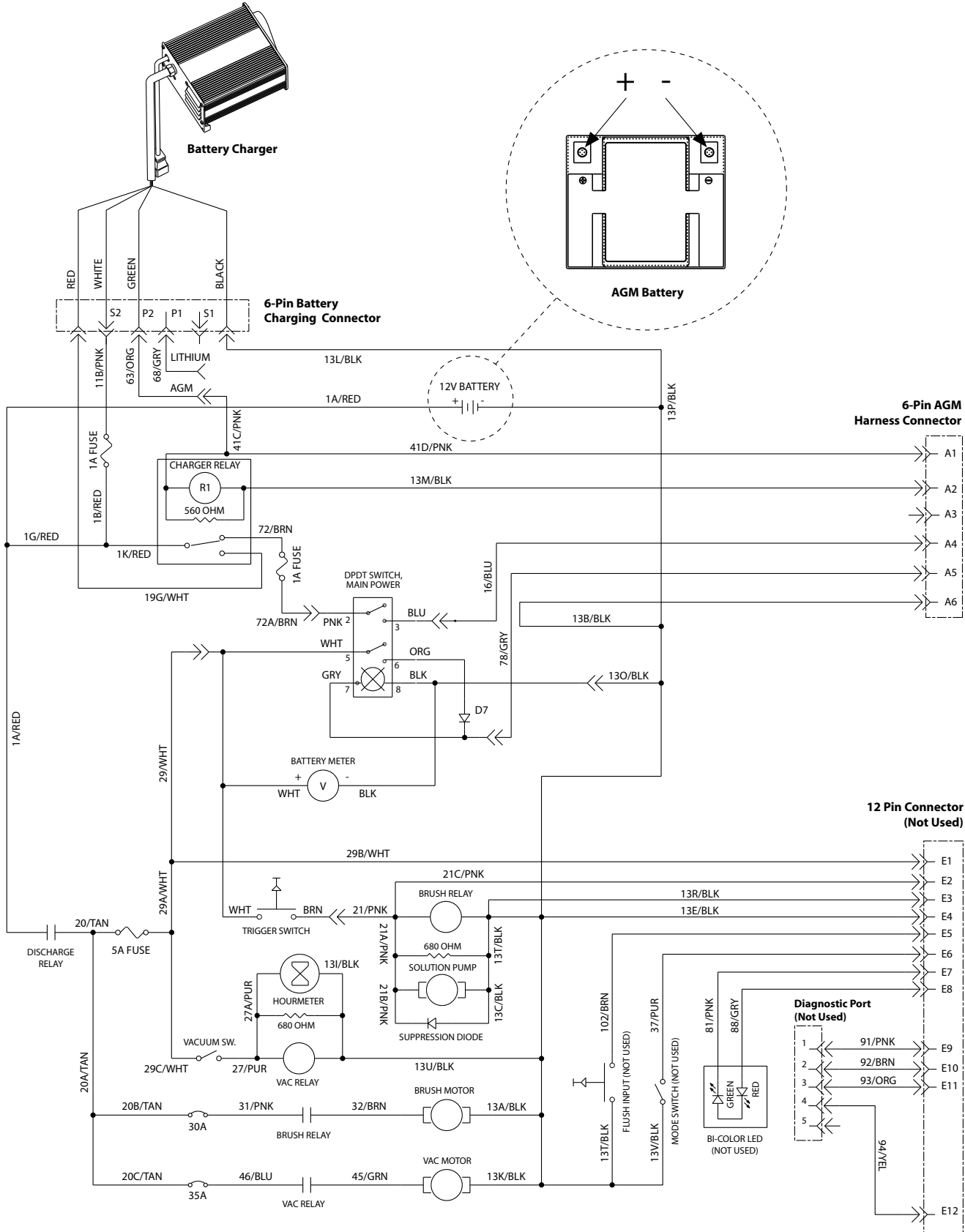

ELECTRICAL SCHEMATIC - AGM BATTERY (2 of 2)

**6-Pin AGM
Harness Connector**

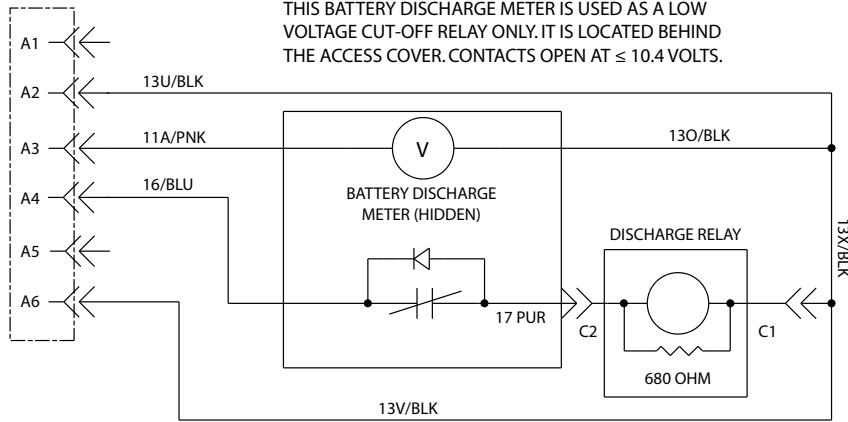

NOTE:

THIS BATTERY DISCHARGE METER IS USED AS A LOW VOLTAGE CUT-OFF RELAY ONLY. IT IS LOCATED BEHIND THE ACCESS COVER. CONTACTS OPEN AT ≤ 10.4 VOLTS.

GENERAL INFORMATION

FASTENER TORQUE

SAE (STANDARD)

Thread Size	SAE Grade 1	SAE Grade 2 Carriage Bolts	Thread Cutting Thread Rolling	SAE Grade 5 Socket & Stainless Steel	SAE Grade 8	Headless Socket Set Screws	Square Head Set Screws
4 (.112)	(5) - (6.5)					(4) - (6)	
5 (.125)	(6) - (8)					(9) - (11)	
6 (.138)	(7) - (9)		(20) - (24)			(9) - (11)	
8 (.164)	(12) - (16)		(40) - (47)			(17) - (23)	
10 (.190)	(20) - (26)		(50) - (60)			(31) - (41)	
1/4 (.250)	4 - 5	5 - 6	7 - 10	7 - 10	10 - 13	6 - 8	17 - 19
5/16 (.312)	7 - 9	9 - 12	15 - 20	15 - 20	20 - 26	13 - 15	32 - 38
3/8 (.375)	13 - 17	16 - 21		27 - 35	36 - 47	22 - 26	65 - 75
7/16 (.438)	20 - 26	26 - 34		43 - 56	53 - 76	33 - 39	106 - 124
1/2 (.500)	27 - 35	39 - 51		65 - 85	89 - 116	48 - 56	162 - 188
5/8 (.625)		80 - 104		130 - 170	171 - 265		228 - 383
3/4 (.750)		129 - 168		215 - 280	313 - 407		592 - 688
1 (1.000)		258 - 335		500 - 650	757 - 984		1281 - 1489

METRIC

Thread Size	4.8/5.6	8.8 Stainless Steel	10.9	12.9	Set Screws
M3	43 - 56 Ncm	99 - 128 Ncm	139 - 180 Ncm	166 - 215 Ncm	61 - 79 Ncm
M4	99 - 128 Ncm	223 - 290 Ncm	316 - 410 Ncm	381 - 495 Ncm	219 - 285 Ncm
M5	193 - 250 Ncm	443 - 575 Ncm	624 - 810 Ncm	747 - 970 Ncm	427 - 554 Ncm
M6	3.3 - 4.3 Nm	7.6 - 9.9 Nm	10.8 - 14 Nm	12.7 - 16.5 Nm	7.5 - 9.8 Nm
M8	8.1 - 10.5 Nm	18.5 - 24 Nm	26.2 - 34 Nm	31 - 40 Nm	18.3 - 23.7 Nm
M10	16 - 21 Nm	37 - 48 Nm	52 - 67 Nm	63 - 81 Nm	
M12	28 - 36 Nm	64 - 83 Nm	90 - 117 Nm	108 - 140 Nm	
M14	45 - 58 Nm	102 - 132 Nm	142 - 185 Nm	169 - 220 Nm	
M16	68 - 88 Nm	154 - 200 Nm	219 - 285 Nm	262 - 340 Nm	
M20	132 - 171 Nm	300 - 390 Nm	424 - 550 Nm	508 - 660 Nm	
M22	177 - 230 Nm	409 - 530 Nm	574 - 745 Nm	686 - 890 Nm	
M24	227 - 295 Nm	520 - 675 Nm	732 - 950 Nm	879 - 1140 Nm	

SPECIFICATIONS

MACHINE SPECIFICATIONS

MODEL	T1 BATTERY
Length	27.4 in / 695 mm with handle folded
Width	19.8 in / 502 mm
Height	23.4 in / 594 mm with handle folded
	38 in / 965 mm with handle in working position
Weight	110 lb / 50 kg with Lithium-ion battery
	126 lb / 57 kg with AGM battery
Solution Tank Capacity	2.5 gal / 9.5 L
Recovery Tank Capacity	3.4 gal / 12.9 L
Productivity Rate - AVG.*	7743 ft ² / 719 m ² /hr
Cleaning Path Width	15 in / 381 mm
Squeegee Width	17.5 in / 444 mm
Brush Pressure	38 lb / 17 kg
Brush Motor	12.8 VDC, 0.65 hp / 0.49 kW, 900 brush RPM
Vacuum Motor	12.8 VDC, 0.5 hp / 0.38 kW, 1-Stage 5.7 in
Water Lift	12.0 in / 305 mm Operating - 25.0 in / 635 mm Sealed
Solution Pump	12.8 VDC, 0.16 hp / 11.9 W
Solution Flow Rate	0.10 gal / 0.38 L/min
Battery Capacity	12V Lithium-ion, 40 Ah / 512Wh
	12V AGM, 50 Ah / 600Wh
Machine Run Time	Up to 60 min-Lithium-ion battery, Up to 45 min - AGM battery
Voltage	12 VDC Nominal
Total Power Consumption	500W
Battery Charger (Supplied with AGM Model)	120/220-240 VAC, 4.8/2.4 A, 50/60 Hz, 14.6 VDC, 10 A Output
Battery Charger (Supplied with Lithium-ion Model)	120/220-240 VAC, 4.8/2.4 A, 50/60 Hz, 14.6 VDC, 15 A Output
Decibel Rating at Operator's Ear, Indoors** Level of Uncertainty	68 dBA
	3 dBA
Vibrations at Hand Controls	<2.5m/s ²
Protection Grade	IPX3

* Estimated coverage rates use the practical speed and empty/fill time standards from the 2004 ISSA Cleaning Times handbook.

** Sounds levels (ISO 11201) as recommended by the American Association of Cleaning Equipment Manufacturers (AACEM) and OSHA.

MACHINE DIMENSIONS

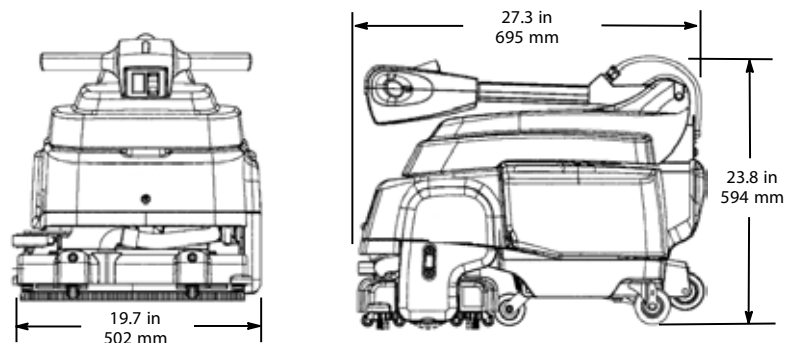

GENERAL INFORMATION

SPECIFICATIONS

ELECTRICAL COMPONENTS *(For Reference Only)*

Component	Measure
Relay Coil, Charge	70 Ω +/- 5%
Relay Coil, Discharge	70 Ω +/- 5%
Relay Coil, Brush	70 Ω +/- 5%
Relay Coil, Vacuum	70 Ω +/- 5%
Motor, Solution Pump	0.9 - 2 Amps Continuous
Motor, Brush	7 - 12 Amps Continuous
Motor, Vacuum	25 - 32 Amps Continuous

SECTION 3

Contents	Page
Maintenance	3-1
Machine Maintenance.....	3-2
After Each Use	3-2
After Weekly Use.....	3-2
Vacuum Hose.....	3-3
Squeegee Blade Replacement.....	3-4
Transporting Machine.....	3-4
Storing Machine	3-5

MAINTENANCE

MACHINE MAINTENANCE

To keep the machine in good working condition, simply follow the machine's maintenance procedures.

FOR SAFETY: Before performing any maintenance procedures turn the main power switch to the off position.

FOR SAFETY: When servicing machine, all repairs must be performed by a qualified service person.

AFTER EACH USE

1. Empty the recovery tank and thoroughly rinse with clean water (Figure 25).



FIG. 25

2. Recharge the battery (Figure 26).



FIG. 26

3. Raise the scrub head to the transport position to prevent flat spot on brush (Figure 27).



FIG. 27

AFTER WEEKLY USE

1. Clean the vacuum shut-off float with damp cloth (Figure 28) and remove any debris buildup from vacuum intake screen (Figure 29).

ATTENTION: Be careful not to get water in vacuum intake screen, vacuum damage may result.

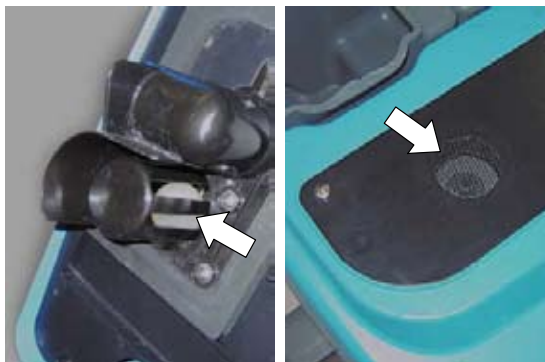

FIG. 28

FIG. 29

2. Remove the brush and check for entangled debris (Figure 30). Replace brush if damaged or worn.



FIG. 30

3. Tilt the machine back and clean the underside of the scrub head (Figure 31).

FOR SAFETY: Before tilting machine, turn the main power switch to the off position and empty tanks.



FIG. 31

- Wipe the squeegee blades (Figure 32). Replace the blades if worn or damaged. Remove any clogged debris inside both inlet openings.

FOR SAFETY: Before tilting machine, turn the main power switch to the off position and empty tanks.

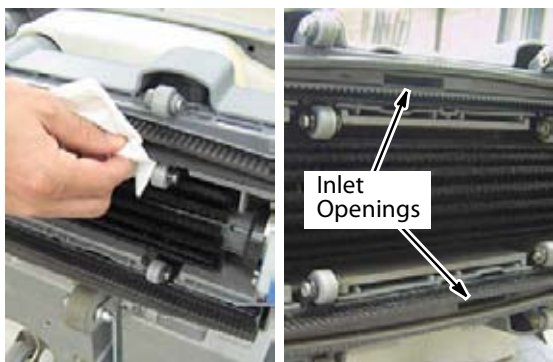

FIG. 32

- Clean the machine with an all purpose cleaner and damp cloth (Figure 33).

FOR SAFETY: When cleaning machine, do not power spray or hose off machine. Electrical malfunction may occur.



FIG. 33

- Clean the solution hose screen (Figure 34).



FIG. 34

VACUUM HOSE MAINTENANCE

To prevent debris buildup in vacuum system, flush vacuum hose as described below:

- Place machine over floor drain and turn the main power switch to the off position (Figure 35).



FIG. 35

- Place a dry towel over the vacuum intake screen to prevent water from entering vacuum motor (Figure 36).
- With water turned off, insert a garden hose into the vacuum intake hose as shown (Figure 37).



FIG. 36



FIG. 37

- Slowly turn on water to prevent back-splash if vacuum system is clogged. Increase water pressure to flush out debris buildup.

NOTE: The vacuum hose is Y-shaped. Make sure to flush out both sides (Figure 38).



FIG. 38

MAINTENANCE

SQUEEGEE BLADE REPLACEMENT

Tilt the machine back to access the squeegee blades.

FOR SAFETY: Before tilting machine, turn the main power switch to the off position and empty tanks.

To remove the squeegee blades, lift the blade retainer clip and pull the blade from the channel (Figure 39).

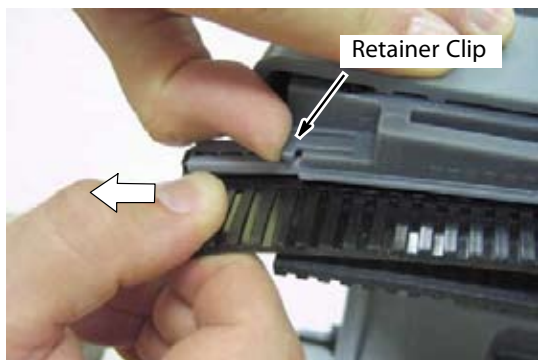

FIG. 39

For easy blade installation, the squeegee blades are color coded to match the scrub head blade channel (Figure 40).

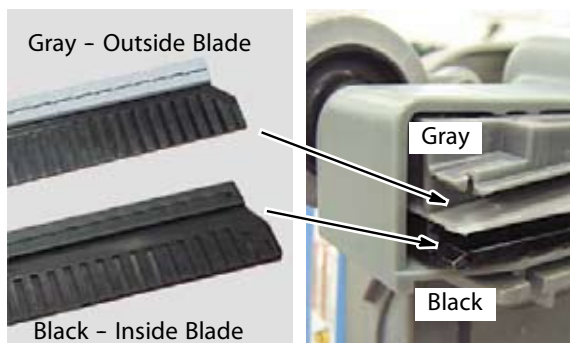

FIG. 40

To install blade, slide each blade into the appropriate channel until retainer clip engages blade (Figure 41). The squeegee blade ribs should face away from each other.



FIG. 41

TRANSPORTING MACHINE

Before transporting machine, empty water from tanks and turn the main power switch to the off position.

FOR SAFETY: When transporting machine, get assistance or use a mechanical lift when lifting machine.

FOR SAFETY: When transporting machine, use tie-down straps to secure machine.

To wheel machine from room to room, raise the scrub head to the transport position and push the machine forward (Figure 42).

DO NOT tilt machine on the rear wheels. Only use the rear wheels to transport machine up and down a curb.



FIG. 42



FOR SAFETY: When transporting machine, do not tilt on rear wheels and do not wheel up or down stairs. Get assistance or use a mechanical lift when lifting machine.

STORING MACHINE

Before storing machine, empty tanks and fully charge the battery.

Store the machine in an open, well-ventilated, dry and clean area less than 113°F/45°C in the upright position.

Raise the scrub head to the transport position.

If storing machine in freezing temperatures, make sure to purge all water from solution system.

To purge water from solution system, empty solution tank, and operate the machine as normal for approximately 15 seconds.

 WARNING: Electrical Shock Hazard. Do Not Use Outdoors. Do Not Expose to Rain/Moisture. Store Indoors.

Notes:

SECTION 4

Contents	Page
Troubleshooting	4-1
Battery Charger and BMS, Lithium-ion	4-2
Operation.....	4-2
Faults.....	4-2
Battery Management System (BMS).....	4-2
Battery Charger, AGM	4-3
Operation.....	4-3
Configuration.....	4-3
Displaying Current Settings.....	4-3
Checking DIP Switches	4-3
Faults.....	4-3
Subsystem Troubleshooting	4-4
Lithium-ion Battery	4-4
Charger Connected (0-5 Seconds)	4-4
Electrical Schematic.....	4-4
Troubleshooting	4-5
Charger Connected (5+ Seconds)	4-6
Electrical Schematic.....	4-6
Troubleshooting	4-7
Power Up Circuit (0-5 Seconds)	4-8
Electrical Schematic.....	4-8
Troubleshooting	4-9
Power Up Circuit (5+ Seconds).....	4-10
Electrical Schematic.....	4-10
Troubleshooting	4-11
AGM Battery	4-12
Charger Connected	4-12
Electrical Schematic.....	4-12
Troubleshooting	4-13
Power Up Circuit	4-14
Electrical Schematic.....	4-14
Troubleshooting	4-15

TROUBLESHOOTING

Battery Charger and BMS, Lithium-ion

OPERATION, BATTERY CHARGER

The Lithium-ion battery charger utilizes 3 green control indicator LEDs; 100%, 75%, and 50% as shown below.

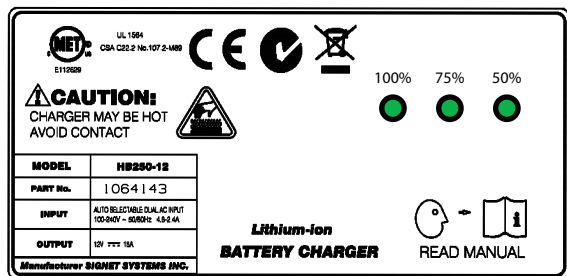

See the table below for normal LED operation.

LED \ CHARGE	100%	75%	50%
0-50%	Off	Off	Blinking
50-75%	Off	Blinking	On
75-100%	Blinking	On	On
100%	On	On	On
Abnormal*	Blinking	Off	Off

* Abnormal cycle = > 5 hours constant current or > 8 hours total charging time.

FAULTS

Fault messages automatically display when a fault exists. Use the table below to identify possible causes.

3 LED FAULT*	POSSIBLE CAUSE
Blinking 1x	<ul style="list-style-type: none"> • Output open or shorted • Output voltage over limit • Output terminals polarity reversed
Blinking 2x	<ul style="list-style-type: none"> • Input voltage out of range
Blinking 3x	<ul style="list-style-type: none"> • High internal temperature
Blinking 4x	<ul style="list-style-type: none"> • Output current exceeds limit

* 3 LED FAULT = All 3 LEDs blink on/off simultaneously. 1x, 2x, 3x, and 4x refers to groups of blinking LEDs separated by a long pause.

BATTERY MANAGEMENT SYSTEM (BMS)

The Lithium-ion battery has a built-in BMS. The BMS has a single status LED as shown below.



See the table below for status LED operation.

LED STATUS	POSSIBLE CAUSE
Green Flashing (Normal)	<ul style="list-style-type: none"> • 1 per 5 seconds = Active Mode • 1 per 20 seconds = Sleep Mode
Yellow Flashing	<ul style="list-style-type: none"> • High internal temperature/High load
Red Flashing	<ul style="list-style-type: none"> • Very low or very high cell voltage
No LED	<ul style="list-style-type: none"> • Contact Tennant Technical Support

Battery Charger, AGM

OPERATION

The AGM battery charger utilizes 3 control indicator LEDs; Red, Yellow, and Green. See the table below for normal LED operation.

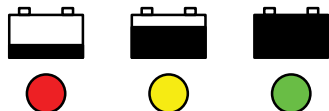

Red LED On	First phase of charge in progress
Yellow LED On	Second phase of charge in progress
Green LED On	Charge complete

CONFIGURATION

DISPLAYING CURRENT CHARGER SETTING

1. Key Off. Disconnect battery charger from AC power supply and the battery. Wait 30 seconds before proceeding to step 2 to allow for capacitor discharge.
2. Connect charger to AC supply and observe the LED display. The green or red LED flashes twice indicating the current charger setting. The yellow LED flashes continuously after the initial charger setting is displayed.

LED	BATTERY TYPE
Green	Configured for AGM
Red	Configured for Lead-acid (Wet)

CHECKING CHARGER DIP SWITCH SETTING

1. Key Off. Disconnect battery charger from AC power supply and the battery. Wait 30 seconds before proceeding to step 2 to allow for capacitor discharge.
2. Remove screws that fasten the vented cover to the charger body to expose the dip switches.
3. Check the dip switches to be sure they are in the AGM battery position as shown below.

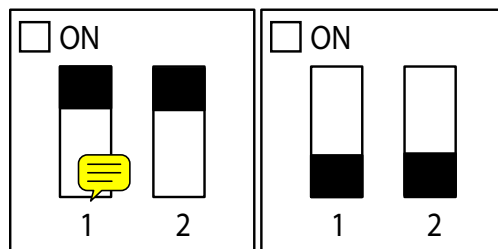

4. Reinstall vented cover mounting screws and reconnect battery cables.

FAULTS

A flashing red or yellow LED indicates a charging error. See the table below for flashing LED faults.

FLASHING LED	POSSIBLE CAUSE
Yellow	<ul style="list-style-type: none"> • Unsuitable Battery • Battery Not Connected • Output Circuit Shorted
Red	<ul style="list-style-type: none"> • Safety Timer Exceeded • Internal Short Circuit

Battery Failed to Charge, Lithium-ion (0-5 Seconds)

STEP	ACTION	VALUE(S)	YES	NO
1	<ul style="list-style-type: none"> • Main power switch Off • Connect battery charger to AC supply and scrubber charging connector • Is there a pertinent fault displayed on the battery charger? 	See "Battery Charger, Lithium-ion, Faults" Section of This Manual	Correct Fault Condition	Go to Step #2
2	<ul style="list-style-type: none"> • Main power switch Off • Check AC power supply • Is the rated AC supply voltage present? 		Go to Step #3	Check AC Supply Circuit Protection
3	<ul style="list-style-type: none"> • Main power switch Off • Remove rear access panel from scrubber to expose battery and BMS (battery management system) • Check the BMS status LED • Is the status LED indicating a fault? 	See "Battery Management System" in the troubleshooting Section of This Manual	Correct Fault Condition	Go to Step #4
4	<ul style="list-style-type: none"> • Main power switch Off • Inspect battery, charger, charger cables, and <i>charging connector</i> for damage, corrosion, contamination or terminal problems • Do any of the above conditions exist? 		Repair or Replace Faulty Components	Go to Step #5
5	<ul style="list-style-type: none"> • Main power switch Off • Connect battery charger to AC supply and scrubber charging connector • Test voltage applied to the electrical circuits, during the first 5 seconds after connection, as shown on the electrical schematic • Are the electrical circuits operating as shown on the electrical schematic? 		See "Battery Failed to Charge, Lithium-ion (5+ Seconds)" Troubleshooting Procedure	Identify Voltage Drop Location and Repair or Replace Necessary Components

Terms:

AC = Alternating Current (facility power)

BMS = Battery Management System. Protects Lithium-ion batteries against deep discharge, which will damage the battery.

LED = Light Emitting Diode

TROUBLESHOOTING

Battery Charger Connected, Lithium-ion (5+ Seconds)

Battery +
 Battery -

- BMS turns On Charge Relay Output pin # B3
- This overrides (disables) all scrubbing functions
- Charger now has closed path to battery through charge relay
- Charging begins

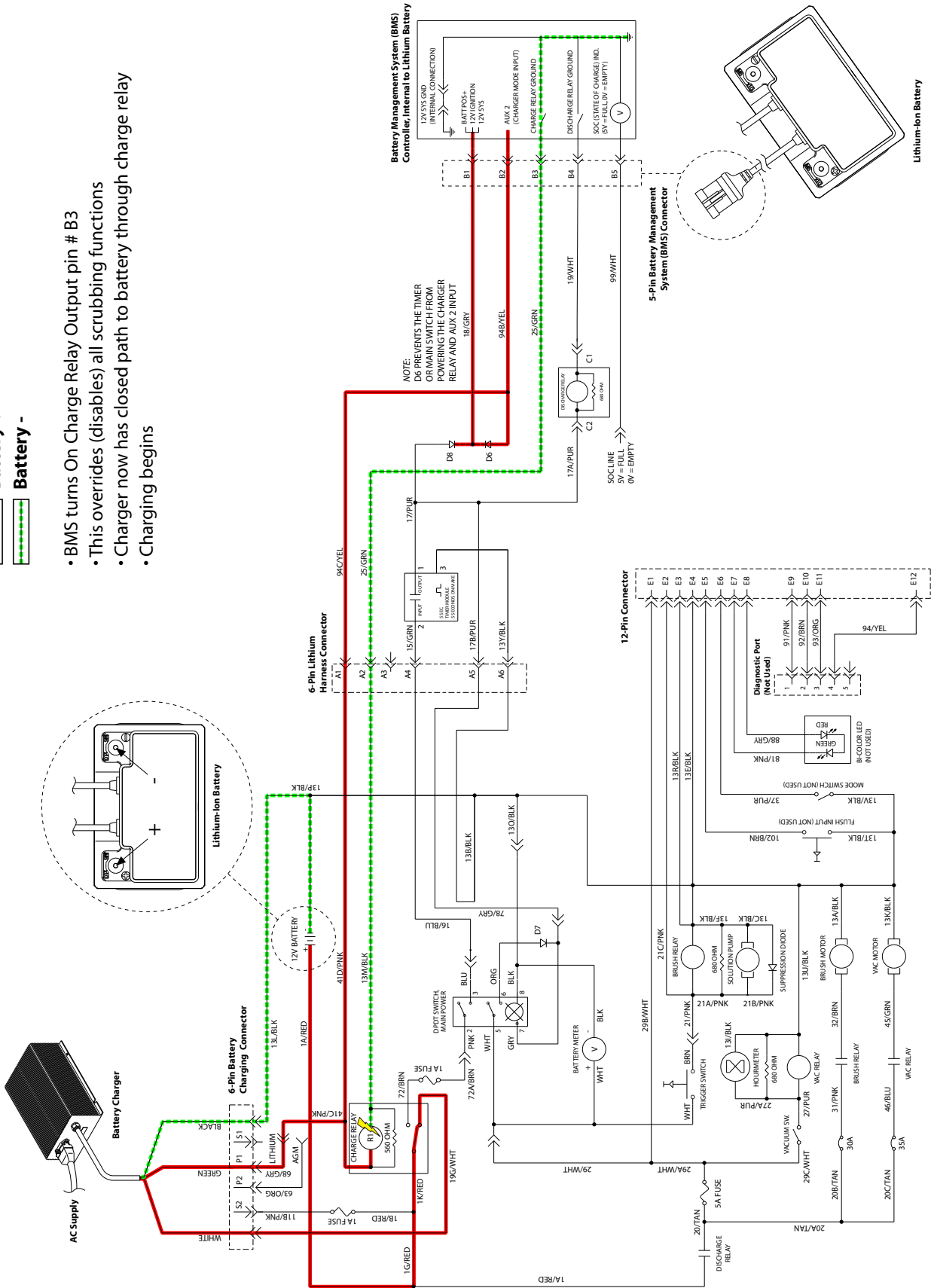

Battery Failed to Charge, Lithium-ion (5+ Seconds)

STEP	ACTION	VALUE(S)	YES	NO
1	<ul style="list-style-type: none"> • Main power switch Off • Has the "Battery Failed to Charge, Lithium-ion (0-5 Seconds)" troubleshooting procedure been completed? 		Go to Step #2	See "Battery Failed to Charge, Lithium-ion (0-5 Seconds)"
2	<ul style="list-style-type: none"> • Main power switch Off • Connect battery charger to AC supply and scrubber charging connector • Wait for 5 seconds after connection and then test voltage applied to the electrical circuits as shown on the electrical schematic • Are the electrical circuits operating as shown on the electrical schematic? 		Go back to Step #1	Identify Voltage Drop Location and Repair or Replace Necessary Components

Terms:

AC = Alternating Current (facility power)

Main Power Up Failure, Lithium-ion (0-5 Seconds)

STEP	ACTION	VALUE(S)	YES	NO
1	<ul style="list-style-type: none"> Main power switch On Does the main power switch illuminate for approximately 5 seconds and then turn Off? 	Battery Voltage Must be > 11.2 Volts	Recharge Battery and if Necessary Go to Step #2	Go to Step #2
2	<ul style="list-style-type: none"> Main power switch Off Remove rear access panel from scrubber to expose battery and BMS (battery management system) Check the BMS status LED Is the status LED indicating a fault? 	See "Battery Management System" in the troubleshooting Section of This Manual	Correct Fault Condition	Go to Step #3
3	<ul style="list-style-type: none"> Main power switch Off Inspect battery, cables, and connections for damage, corrosion, contamination or terminal problems Do any of the above conditions exist? 		Repair or Replace Faulty Components	Go to Step #4
4	<ul style="list-style-type: none"> Main power switch On Test voltage applied to the electrical circuits during the first 5 seconds as shown on the electrical schematic Are the electrical circuits operating as shown on the electrical schematic? 		See "Main Power Up Failure, Lithium-ion (5+ Seconds)" Troubleshooting Procedure	Identify Voltage Drop Location and Repair or Replace Necessary Components

Terms:

BMS = Battery Management System. Protects Lithium-ion batteries against deep discharge, which will damage the battery.

LED = Light Emitting Diode

TROUBLESHOOTING

Main Power Switch On, Lithium-ion (5+ Seconds)

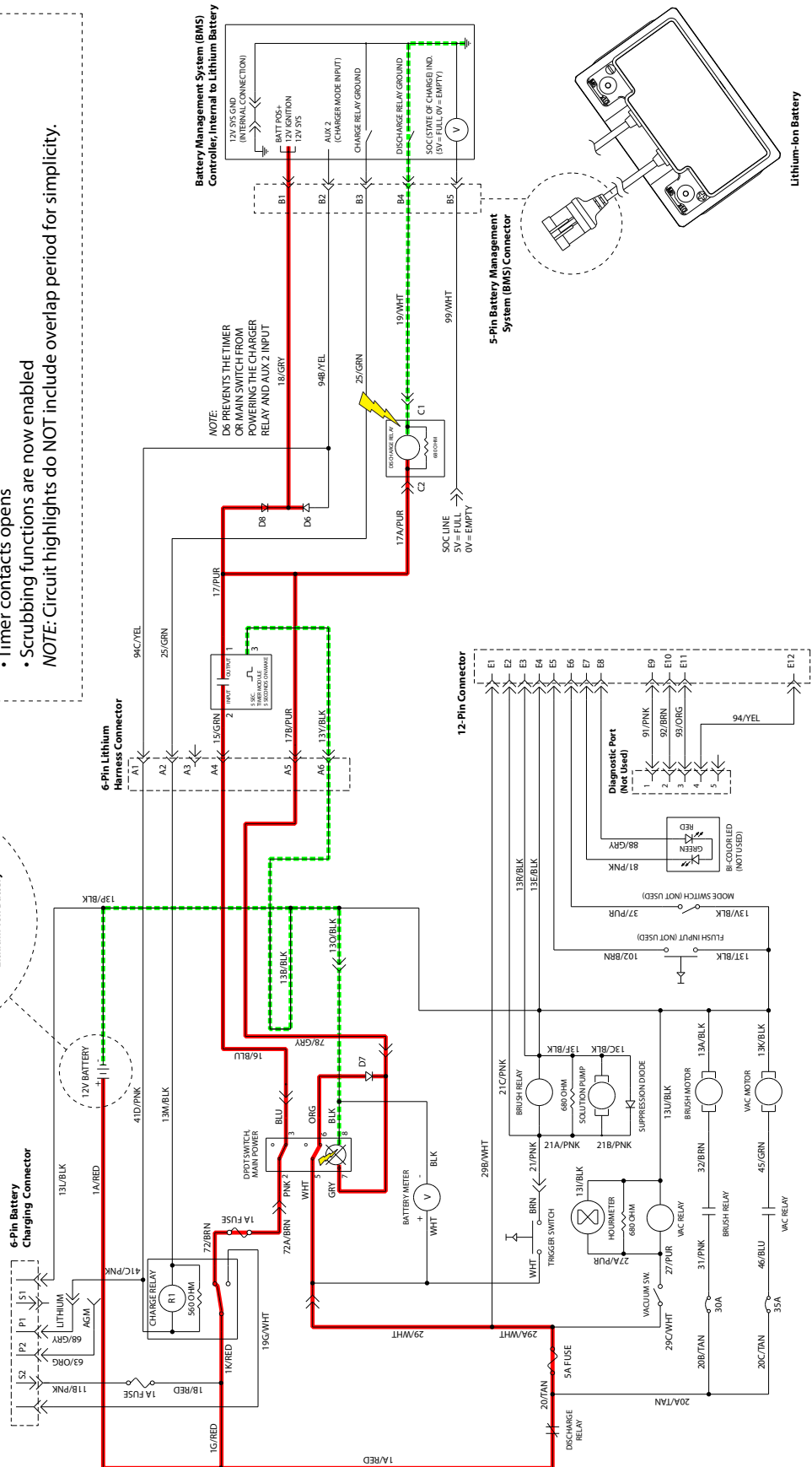
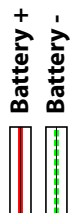
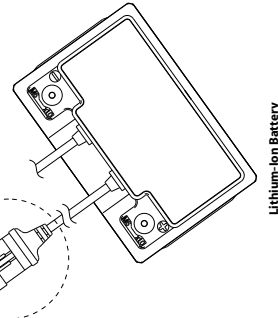
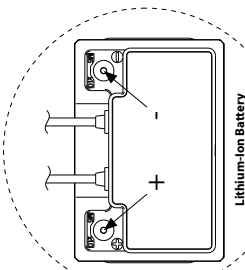
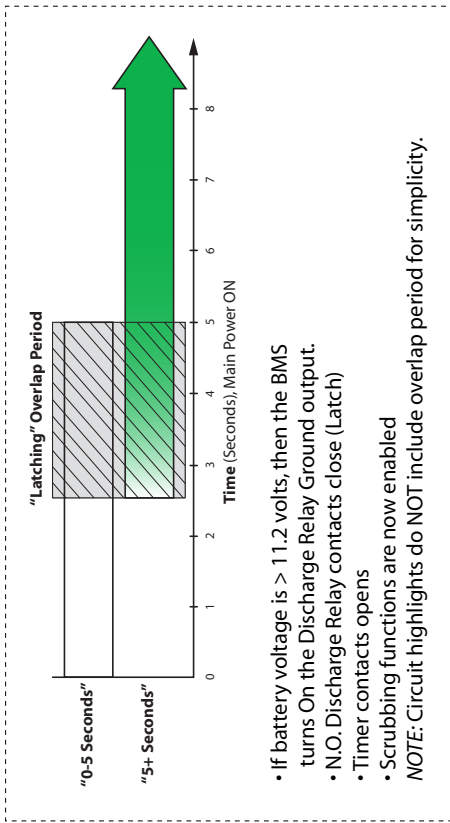

Main Power Up Failure, Lithium-ion (5+ Seconds)

STEP	ACTION	VALUE(S)	YES	NO
1	<ul style="list-style-type: none"> • Main power switch Off • Has the "Main Power Up Failure, Lithium-ion (0-5 Seconds)" troubleshooting procedure been completed? 		Go to Step #2	See "Main Power Up Failure, Lithium-ion (0-5 Seconds)"
2	<ul style="list-style-type: none"> • Main power switch On • Wait for 5 seconds after activating main power switch and then test voltage applied to the electrical circuits as shown on the electrical schematic • Are the electrical circuits operating as shown on the electrical schematic? 		Go back to Step #1	Identify Voltage Drop Location and Repair or Replace Necessary Components

TROUBLESHOOTING

Battery Charger Connected, AGM

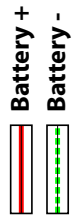

- Battery charger connected
- Charger Interlock Relay contacts close (internal)
- Charge Relay N.O. contacts close
- Charger now has a closed path to battery through Charge Relay.
- Charging begins

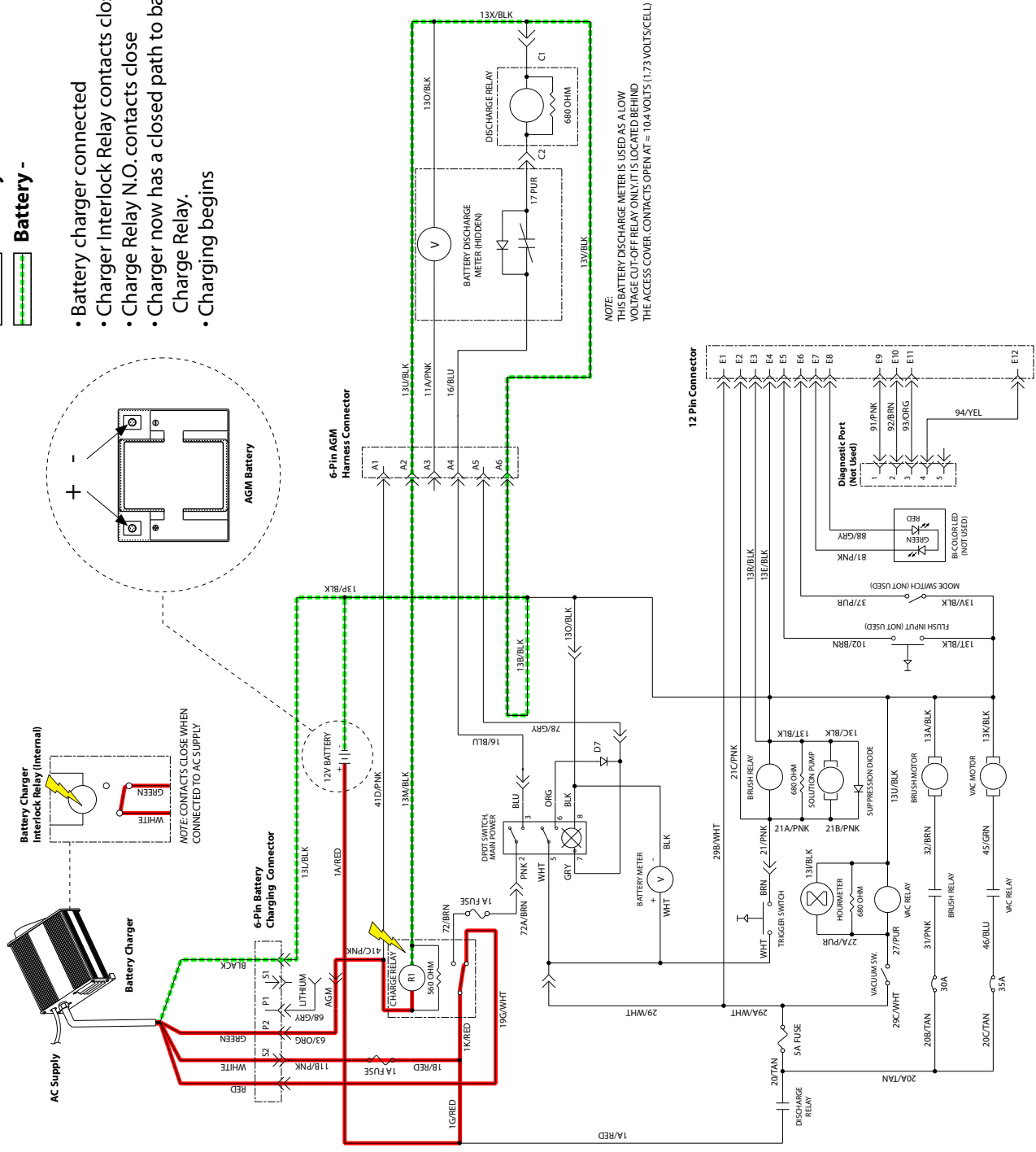
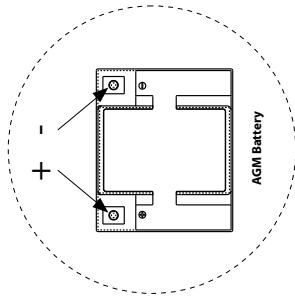

Battery Failed to Charge, AGM

STEP	ACTION	VALUE(S)	YES	NO
1	<ul style="list-style-type: none"> • Main power switch Off • Connect battery charger to AC supply and scrubber charging connector • Is there a pertinent fault displayed on the battery charger? 	See "Battery Charger, AGM, Faults" Section of This Manual	Correct Fault Condition	Go to Step #2
2	<ul style="list-style-type: none"> • Main power switch Off • Check AC power supply • Is the rated AC supply voltage present? 		Go to Step #3	Check AC Supply Circuit Protection
3	<ul style="list-style-type: none"> • Main power switch Off • Inspect battery, charger, charger cables, and <i>charging connector</i> for damage, corrosion, contamination or terminal problems • Do any of the above conditions exist? 		Repair or Replace Faulty Components	Go to Step #4
4	<ul style="list-style-type: none"> • Main power switch Off • Load test AGM battery using a standard load tester • Does the AGM battery pass a load test? 		Go to Step #5	Replace Battery
5	<ul style="list-style-type: none"> • Main power switch Off • Connect battery charger to AC supply and scrubber charging connector • Test voltage applied to the electrical circuits as shown on the electrical schematic • Are the electrical circuits operating as shown on the electrical schematic? 		Go Back to Step #1	Identify Voltage Drop Location and Repair or Replace Necessary Components

Terms:

AC = AC = Alternating Current (facility power)

AGM = Absorbed Glass Mat is a spill proof, maintenance-free battery type.

BMS = Battery Management System. Protects Lithium-ion batteries against deep discharge, which will damage the battery.

LED = Light Emitting Diode

Main Power Up Failure, AGM

STEP	ACTION	VALUE(S)	YES	NO
1	<ul style="list-style-type: none"> • Main power switch On • Does the main power switch light illuminate? 	Battery Voltage Must be > 10.4 Volts	Go to Step #2	Recharge Battery and if Necessary Go to Step #2
2	<ul style="list-style-type: none"> • Main power switch Off • Inspect battery, cables, and connections for damage, corrosion, contamination or terminal problems • Do any of the above conditions exist? 		Repair or Replace Faulty Components	Go to Step #3
3	<ul style="list-style-type: none"> • Main power switch On • Test voltage applied to the electrical circuits as shown on the electrical schematic • Are the electrical circuits operating as shown on the electrical schematic? 		Go Back to Step #1	Identify Voltage Drop Location and Repair or Replace Necessary Components

Terms:

LED = Light Emitting Diode

Notes:



TENNANT COMPANY
 Technical Publications #15
 701 North Liliac Drive
 P.O. Box 1452
 Minneapolis, MN 55440-9947

POSTAGE WILL BE PAID BY ADDRESSEE

BUSINESS REPLY MAIL
 FIRST CLASS MAIL PERMIT NO. 94 MINNEAPOLIS, MN

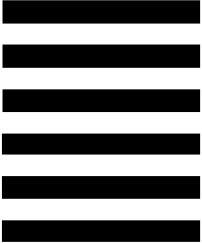

NO POSTAGE
 NECESSARY
 IF MAILED
 IN THE
 UNITED STATES



Fold along dotted lines
 Tape here



TENNANT COMPANY
 Technical Publications #15
 701 North Liliac Drive
 P.O. Box 1452
 Minneapolis, MN 55440-9947

POSTAGE WILL BE PAID BY ADDRESSEE

BUSINESS REPLY MAIL
 FIRST CLASS MAIL PERMIT NO. 94 MINNEAPOLIS, MN

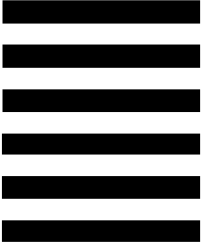

NO POSTAGE
 NECESSARY
 IF MAILED
 IN THE
 UNITED STATES

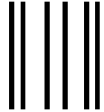

Fold along dotted lines
 Tape here