

Texas Instruments Supplier Packing and Labeling Manual For Global Shipping



Printed specifications are not controlled documents. Verify revision before using

TI Information - Selective Disclosure

Originator: Steve Yager	Date: 11/21/2008	Engineer: Mark Boado/Willy Nisperos	Date: 3/27/09
Designer: Don Wu	Date: 11/21/2008	Approved: T. Weber / D. Colston	Date: 9/21/09
Checker: Chris Durant/Steve Gilboux	Date: 3/6/2009	Released: WDM	Date: 10/02/09
Code Ident 01295	Document number 6512960	Rev M	Sheet 1 of 22

Table of Contents

1. Introduction	3
1.1 Scope	
1.2 Responsibility	
1.3 Application	
1.4 Communication	
1.5 Compliance	
2. Packing Requirements	3
2.1 General	
2.2 Closure	
2.3 Dunnage	
2.4 Unit Load Size and Capacity Requirement	
2.5 Wafer/Silicon packing requirements	
3. Transport Requirements	4
3.1 General	
3.2 Stretch Wrap	
3.3 Banding/Strapping	
3.4 Special Labeling Instructions	
3.5 Pallet Size Requirement	
3.6 Packaging Illustrations	
3.7 Wafer/Silicon transportation requirements	
4. Marking and Labeling	11
4.1 General Requirements	
4.2 Labeling Requirements	
4.3 External Barcode Generation & Information	
4.4 External Barcode Data Requirements	
4.5 Internal Barcode Generation & Information	
4.6 Box Numbering	
5. Packing List Requirements	16
5.1 General	
5.2 Packing List Placement	

1 - Introduction

1.1 Scope

This manual defines the minimum general requirements for the preparation, packing, and labeling of all parts, subassemblies, products, materials, and equipment which will be shipped to any Texas Instruments Incorporated facility.

1.2 Responsibility

It will be the responsibility of Texas Instruments Incorporated and its subsidiaries (TI) to define a preferred packing system, approve the packing plan, and monitor for compliance assurance to Texas Instruments Incorporated requirements. It will be the responsibility of the supplier to:

1. Ensure their packing and labeling methods and materials comply with all applicable laws and regulations that may supersede these requirements.
2. Ensure shipments are economically packed and palletized.
3. Ensure shipment containers and contents are suitably packaged to guard from damages.
4. Ensure export shipments are packed, labeled, and marked as defined by this manual.

1.3 Application

Adherence to the requirements of this manual is necessary to minimize shipping damage, reduce costs, and streamline TI's receiving process.

Special packing specifications called out on a request or purchase order (PO) will take precedence over this specification if they are in conflict.

1.4 Communication

All supplier's questions, communications, and exception requests are to be coordinated through the TI Category Procurement personnel (buyers).

1.5 Compliance

Compliance to the TI packing requirements, safety guidelines, and legal regulations contained in this manual will be enforced as a condition of purchase per TI purchase contracts. TI reserves the right to:

1. Reject and return any shipments that are improperly packed or identified.
2. Charge the supplier for costs of labor and materials for any repacking resulting from non-compliance with this manual or other direction referenced on the PO.
3. Remove from its list of approved supplier sources any supplier that, after notice, repeatedly fails to comply with Texas Instruments Inc. packing requirements.
4. Any shipper requiring deviation from requirements contained in this specification must receive written authorization from the TI Category Procurement personnel prior to shipment.
5. Require a barcode be placed on the box, otherwise a packing slip of approved non-conforming shipments must be noted with the contact phone number of the authorizing TI Commodity Procurement personnel including the date of authorization.

2 - Packing Requirements

The general requirements listed in this section must be met for all shipments and purchases. Unless additional requirements are identified in this or other TI packing specifications or in the applicable PO, all other packing decisions are left to the supplier's discretion.

2.1 General

1. Packing should provide protection from
(a) dust/dirt (particles contamination where appropriate),

- (b) physical damage (dents, abrasion, etc.) to the shipment
- (c) shipping hazards (i.e. shock, compression, moisture, electrostatic discharge)
- 2. Different part numbers are not to be packed in the same intermediate packing container unless it is clearly identified on the package label.
- 3. Boxes should be of sufficient strength to allow stacking during shipment and storage. Do **not** use normal envelopes as shipping containers.
- 4. All packages should be minimum 6750 cubic centimeters (Example: 30cm x 15cm x 15cm) in size, approved exceptions are envelopes using letter services.
- 5. Crates, wirebound boxes, and expendable wooden containers should **not** be used unless corrugated containers do not provide enough protection.

2.2 Closure

- 1. Use pressure sensitive film tape or reinforced gummed tape for **corrugated** containers. Tape must be at least 2 inches (5cm) wide.
- 2. Use strapping or reusable wire brackets for **wooden** crate/containers.
- 3. Use strapping / banding for **half slotted, telescoping** or **sleeve & cap** containers.
- 4. **Never** use staples to close any type of carton, container, or bag.

2.3 Dunnage

- 1. Use corrugated inserts and dividers as applicable.
- 2. Select the right size of container for the parts to minimize dunnage.
- 3. Do **not** use oversized cartons with excessive dunnage.

2.4 Unit Load Size and Capacity Requirements

Load Height Maximum:	72 inches (182.5cm)
Load Weight Maximum:	910 kg (2000 lbs) for a full pallet. 455 kg (1000 lbs) for a half pallet.
Width Exceptions:	Packages greater than 97in. wide require a four-way pallet.
Important:	Pallet overhang is not allowed. Packages in excess of 27kg (60lbs) must be palletized.

***Note:** Pallet height and width may vary depending on mode of transportation.

***Note:** For country-specific requirements see Section 8

2.5 Wafer/Silicon packing requirements

- 2.5.1 Individual wafer boxes should be sealed, stacked up following correct orientation with the arrow pointing upside.
- 2.5.2 There should be a label to indicate contents is fragile.
- 2.5.3 There should be a label to indicate no stacking.

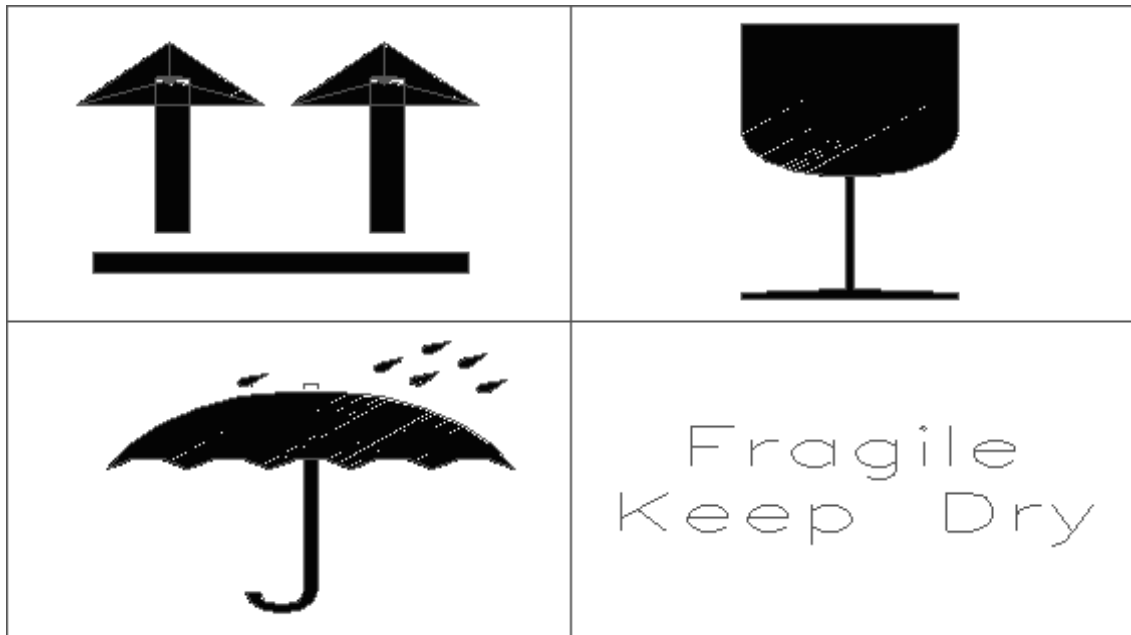

Fig. 1

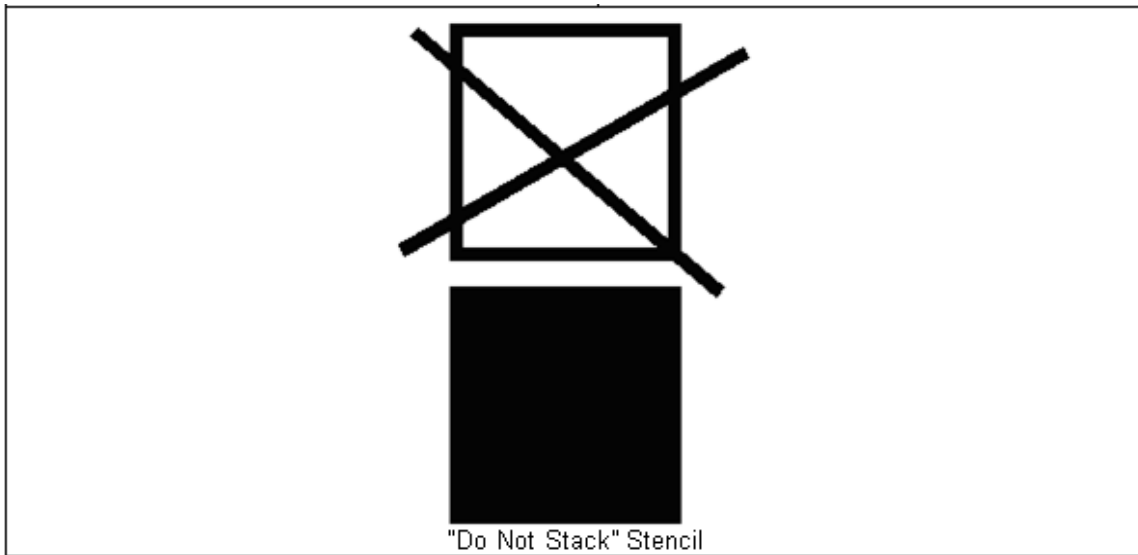

Fig. 2

3 - Transport Requirements**3.1 General**

1. Pallets must be manufactured of a material sufficient to sustain integrity during expected multiple transportation handlings (ie wood, metal, HDPE plastic, etc; corrugated cardboard is not acceptable).
2. Wood pallets must comply with ISPM 15 requirements and marked appropriately.
3. Palletized shipments must be built in cubic, stackable loads and occupy **at least** 80% of the pallet surface unless an individual package is greater than 27kg (60 lbs).
4. Palletize multiple PO's of **one** part number on a single pallet.
5. Remember, do **not**:
 - (a) mix production and non-production materials unless it is labeled as such
 - (b) haystack/pyramid stack containers on a pallet (see following page)
 - (c) allow overhang on palletized shipments (where load exceeds pallet dimensions)

3.2 Stretch Wrap

1. Recommend start with properly adjusted machine which pre-stretches the film.
2. If possible, use 2-way banding before stretch wrapping.
3. Tie the stretch wrap to the pallet directly and cover all corners.
4. Use the "roping technique" – bunching the stretch films full width to create a rope. Stretch film roping is extremely strong and is often used to further secure a pallet to its load. Bunching stretch film is a feature function of many stretch wrap machines (ex: turntable stretch wrappers) - especially around the base.

3.3 Banding / Strapping (where applicable)

1. Use polyester banding – **at least** 13mm (0.50 in.) wide and 0.5mm (0.020 in.) thick.
2. Use steel banding for loads over 363kg (800lbs).
3. Use crimp or heat seal banding closures.
4. Use 2-way banding plus stretch wrap.
5. Use the banding notches (not the fork notch) for cross bands on stringer pallets.
6. Use angleboard-style corner board edge protectors under **all bands and on sides and top edges**.

3.4 Special Labeling Instructions

1. When multiple cartons are shipped on a pallet (without a Unit Load shipper), **at least** one of the labeled sides of each carton must face an exterior edge of the pallet.
2. The carton that contains the packing slip must be located on the **top layer** of cartons with the packing slip facing an exterior edge of the pallet.
3. If the packing slip is enclosed within one of the palletized cartons, the carton must be located on the top layer and identified (1 of total #)
4. Any labeling that is applied by the Carrier must not be placed over top of the content labels that are applied by the supplier.

3.5 Pallet Size Requirements

Industry standard pallets are required for all palletized parts shipments. Acceptable pallet dimensions are:

- 42 inches (106cm) wide x 42 inches (106cm) deep
- 40 inches (101cm) wide x 48 inches (122cm) deep

Contact TI Category Procurement personnel for authorization to deviate from acceptable standard pallet dimensions.

3.6 Packing Illustrations

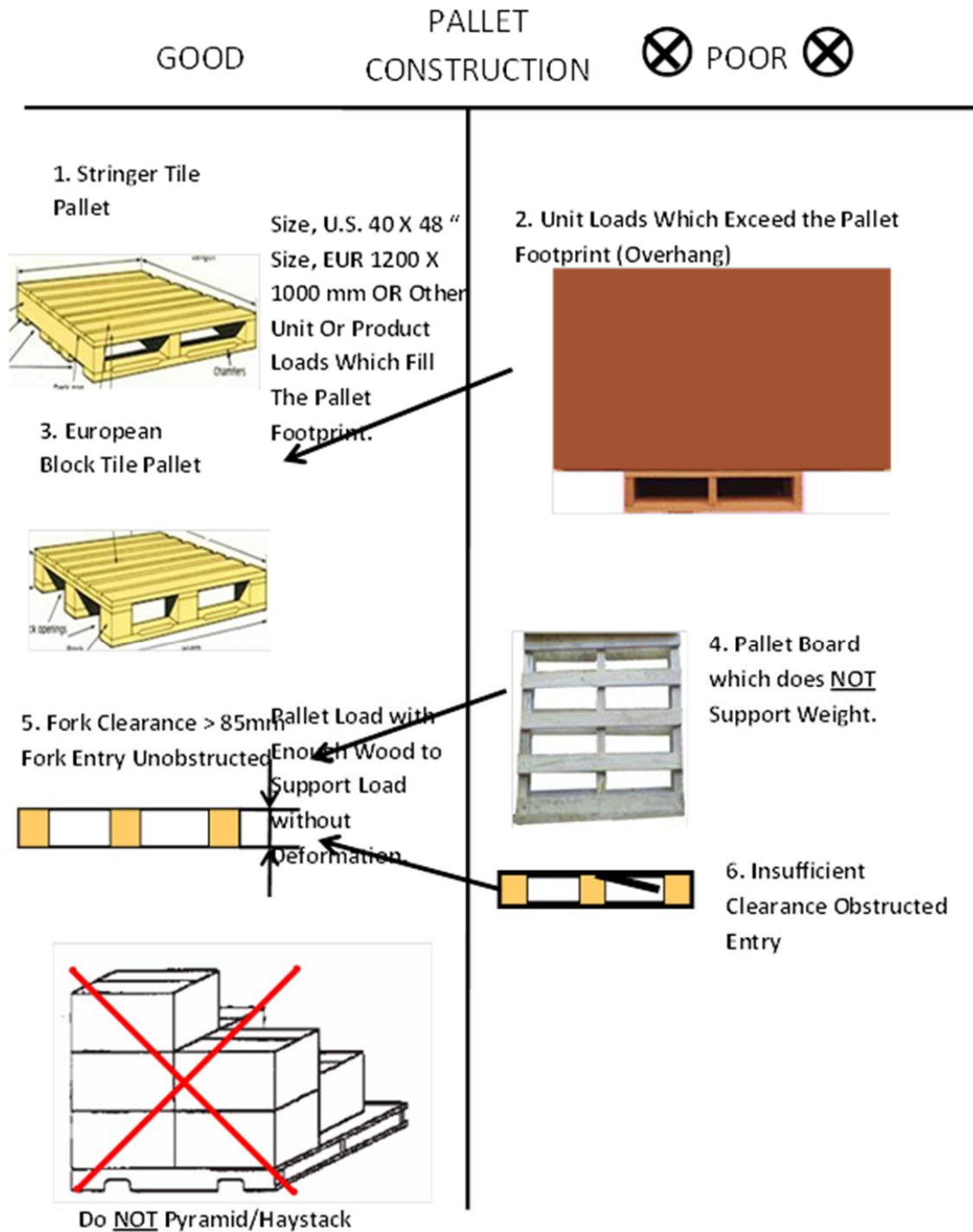

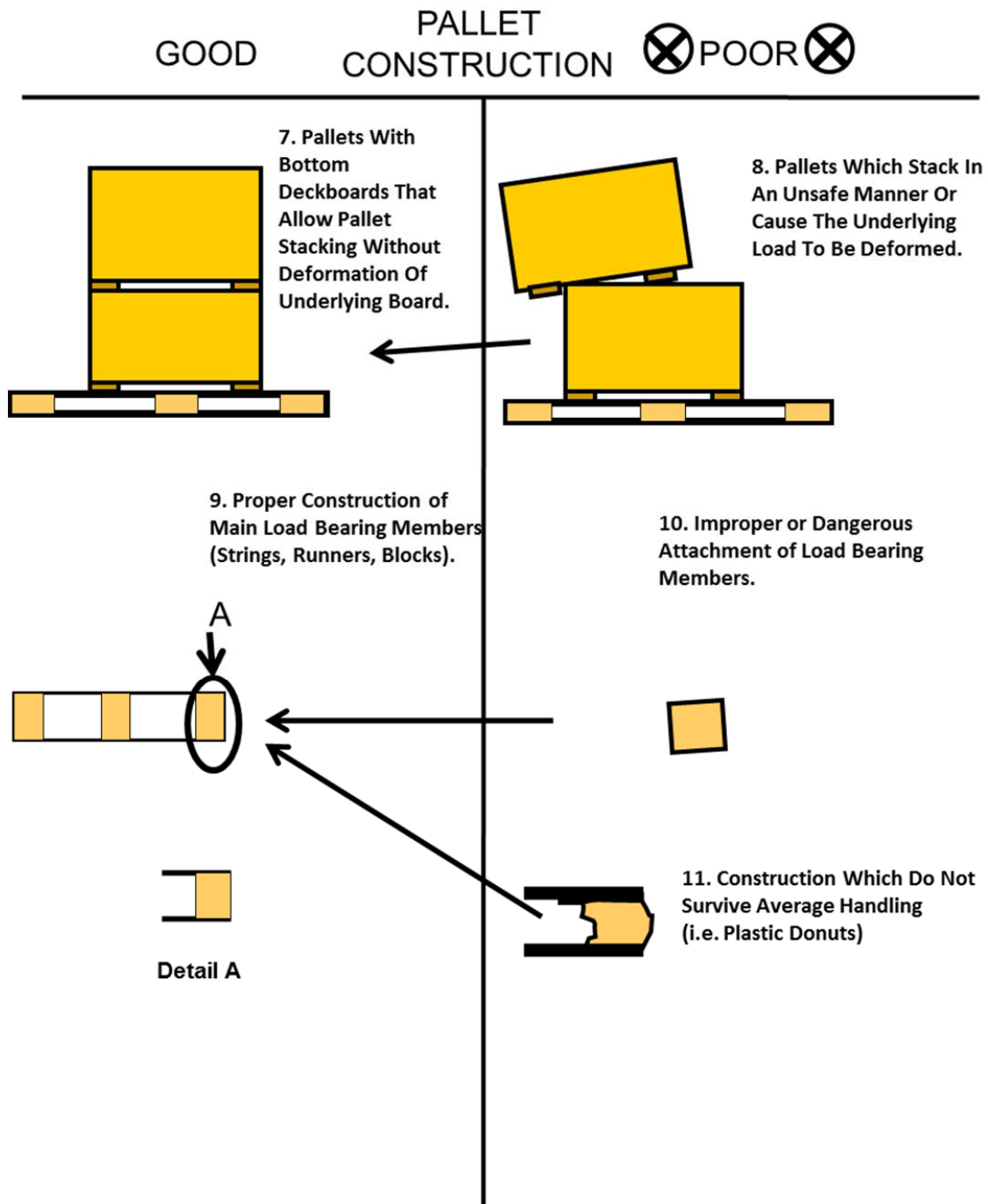

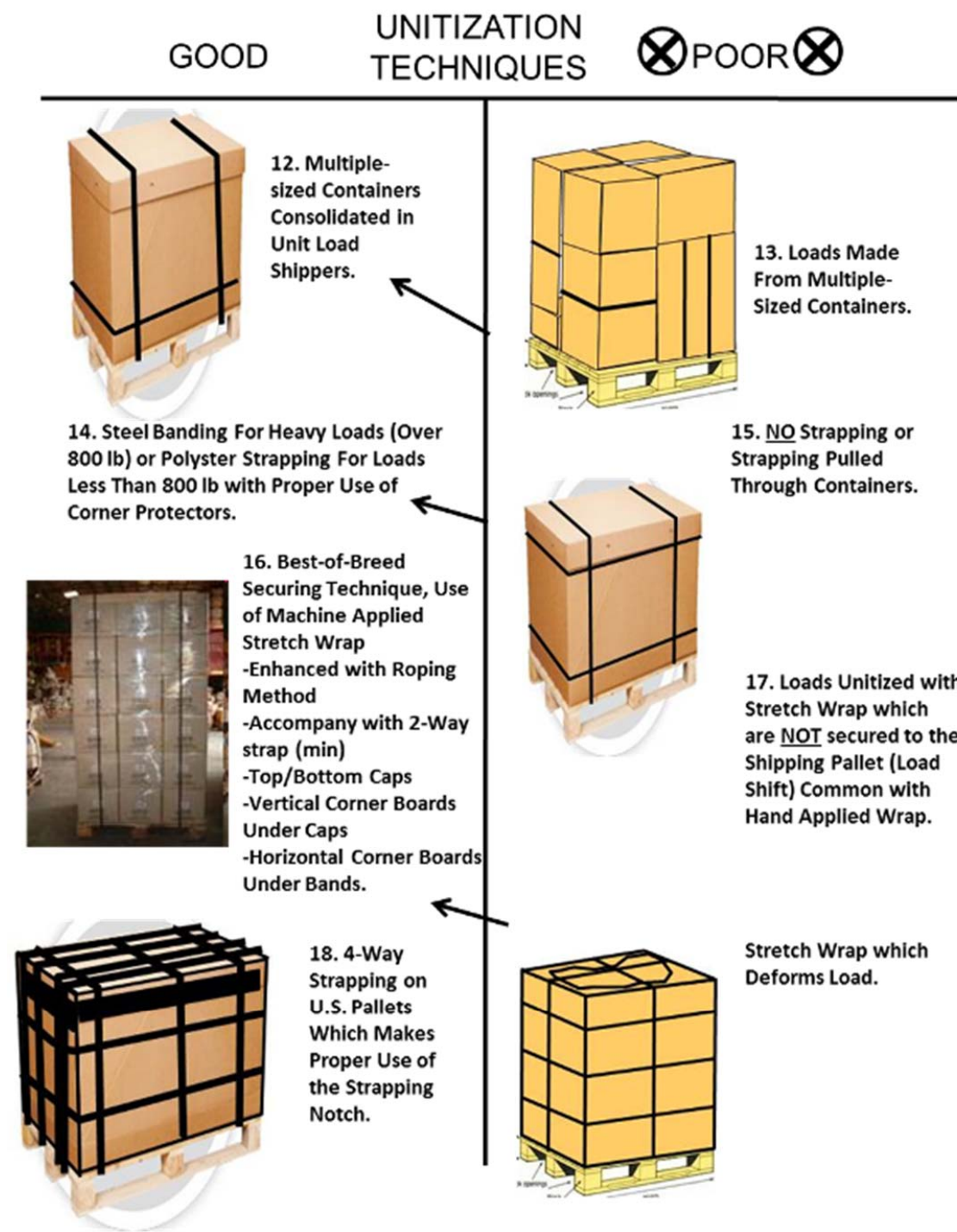

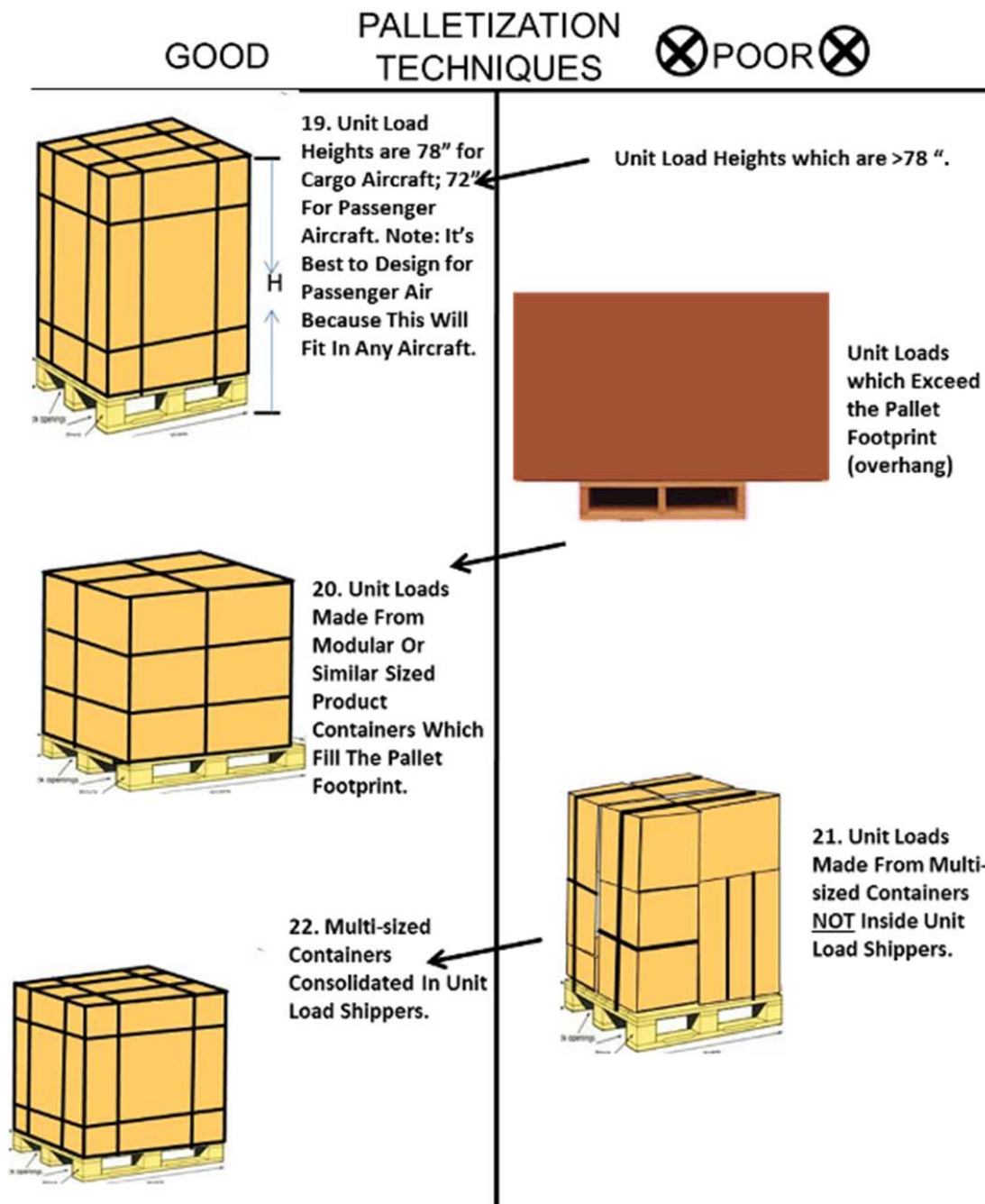

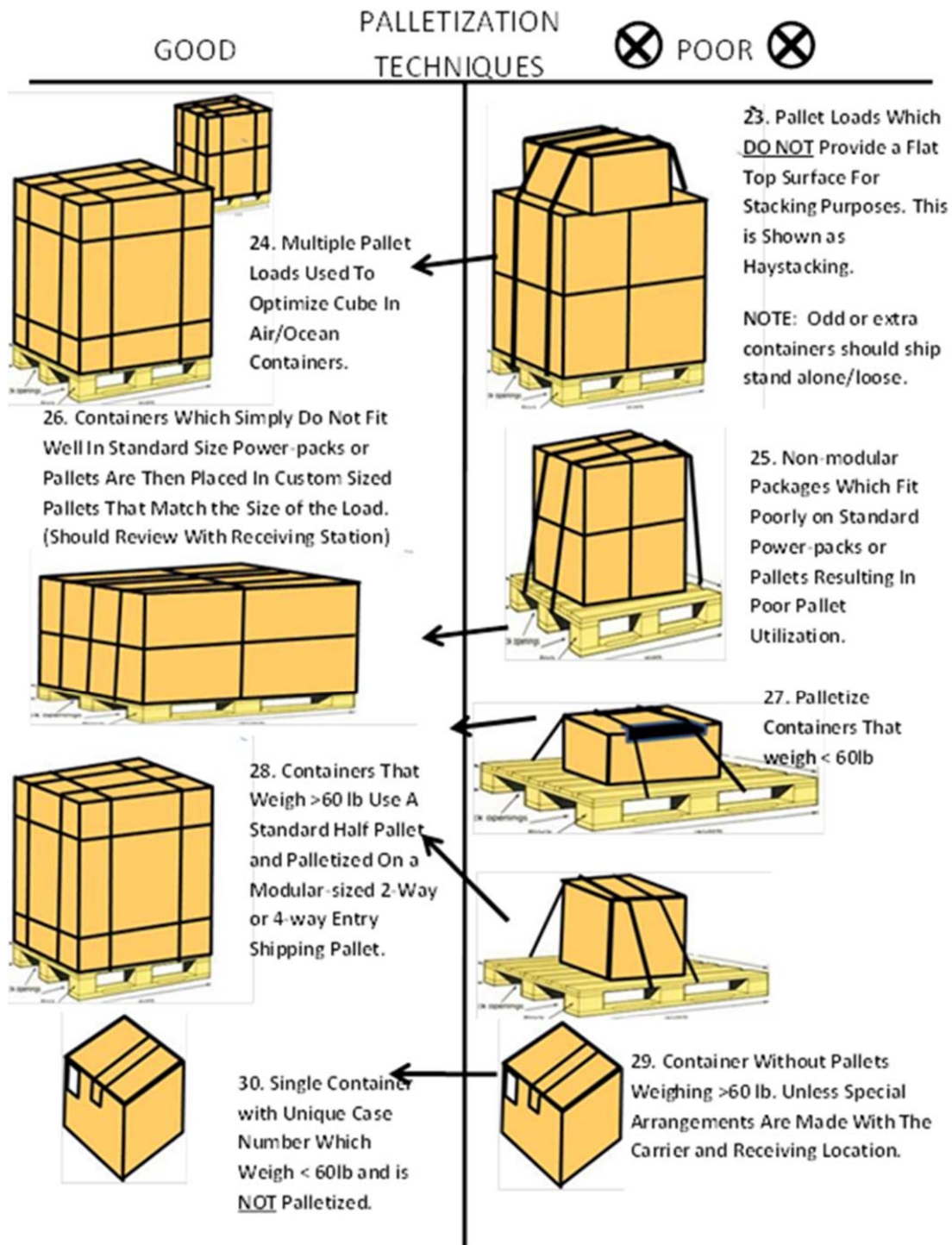

3.7 Wafer/silicon packing requirements.

3.7.1 Silicon wafer pallets may only have **one PO per pallet and one part number (p/n) per pallet**. If a PO contains multiple part numbers, each p/n must be palletized separately. No pallets shall contain multiple POs or multiple part numbers p/n.

3.7.2 Silicon wafer shipments shall be shipped in a cube. If there are empty spaces, the supplier shall use empty boxes to allow complete cube shipments.

3.7.3 Wafer/Silicon shipments should be palletized, corner guards on top and four sides, shrink wrapped and 4-way strap to the pallet/skid. The use of 'Do not stack cones' are highly encourage to prevent stacking of shipments inside the truck. Please refer to the picture below.



Fig. 3

3.7.4 TI transportation forwarder/carrier will inspect material prior to loading into the truck. Any damage seen on the wafer shipment by the transportation forwarder will be documented and communicated to the silicon supplier for further investigation. If repacking is needed, costs associated for labor and materials will be charged to the supplier.



Fig. 4

- 3.7.5 TI encourage the use of hand jack or fork lift with a short blade to load the wafer shipment into the truck. This is to eliminate long fork blades from puncturing wafer shipments during loading and staging.
- 3.7.6 Suppliers shall use recyclable containers for wafer shipment to eliminate breaking down the skid which requires additional handling on US outbound due to Homeland Security's requirement. This packing method helps prevent wafer damages.
- 3.7.7 Over pack or recyclable container shall fit inside a standard 40 x 48 inches pallet. Please refer to the figure below



Fig. 5

- 3.7.7 For International shipments the pallet size allowed for wafer shipment into the universal loading device (ULD 2) is 40 inches (101cm) wide x 48 inches (122cm) deep. The other ULD commonly used for International shipments is ULD 3 which can accommodate a pallet with a maximum dimension of 53 x 43 inches.

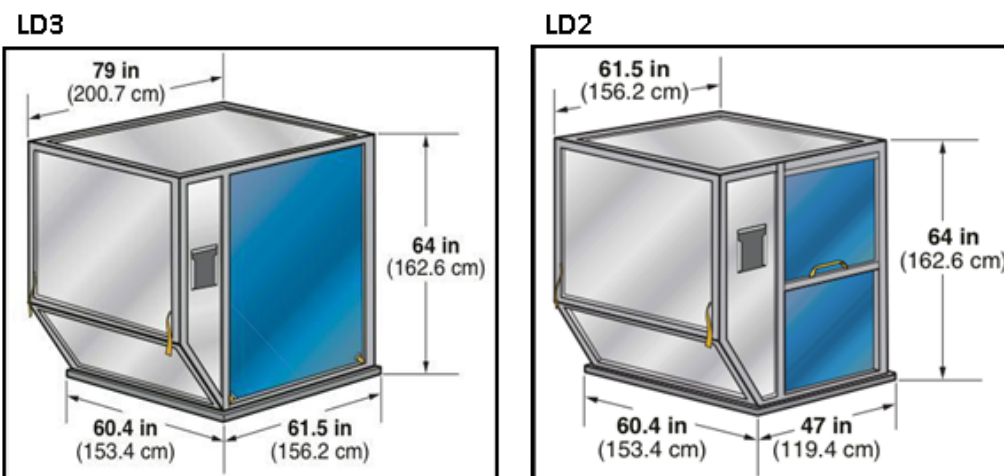

Fig 6

3.7.8 Another device for loading shipment is 'cookie sheet' which is a flat metal where shipments are consolidated. This type of shipment is usually implemented on Freighter planes. A picture of completed 'cookie sheet' is shown below:

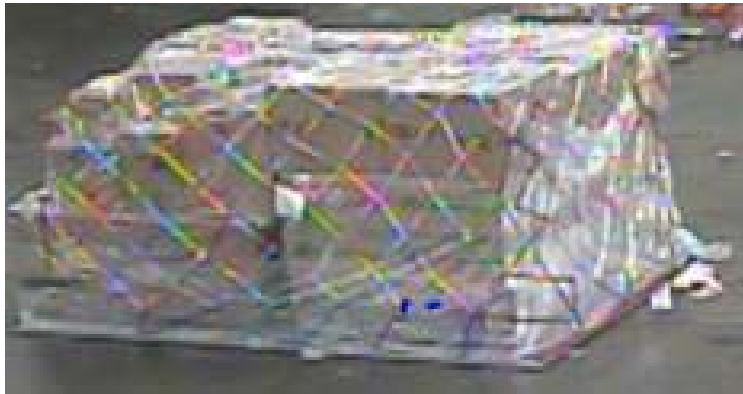

Fig 7

4 - Marking and Labeling

4.1 General

1. Machine generated labels must be legible, indelible, and permanent.
2. Use tags, stamps, or pre-printed cartons in place of labels where appropriate.
3. Do not obscure/cover labels with non-clear tape or banding.
4. Do not leave old labels on re-usable containers.

Cartons / Boxes:

1. Mark the carton with the country of origin if required

Intermediate box: Unit Loads:

1. Mark with country of origin if required.
2. Mark with "mixed" or "multi" if more than one country of origin is packed inside.



4.2 Labeling Requirements

1. Every box needs to be labeled individually even if they are palletized.
2. Each individual box should be labeled with the quantity in that box
3. Receiving and storage of materials requires incoming loads to be easily identified.
4. The "Ship From" Address should be placed on the top left & "Ship To" address on the top right of ship carton label.

4.3 External Barcode Generation & Information

1. An external barcode should be used on all shipments inbound to TI, as it is easy to produce and lowers the risk of human error regarding box labeling.
 - a. If your company does not have barcode technology, you may utilize the barcode print capability (Barcode generator) found at the following web site in order to print conforming barcode labels: <http://barcode.ext.ti.com/>

- b. Use of the web Barcode generator tool to print the barcodes may be browser specific and may not work with all browsers. An example barcode label is shown below. This can be used as a pictorial reference for the below external bar code requirements.
- 2. Recommended label size is 4 inches x 6.5 inches (10.2cm x 16.5cm)
 - a. Requirements are that the label is human readable and fits on the package.
 - b. Human readable text may be placed either above or below the barcode.
 - c. Be aware that text placed too close to either side of a barcode might violate the quiet zone required for the barcode to be reliably read.
- 3. Labels should be affixed to the package OR contained within a pouch on the package, but not both.
 - a. Option 1: One label should be included for each part number/line item shipped. (ie if five boxes are sent with the same PO line item/part number then one label with the total quantity is required on the lead box or shrink-wrapped shipment). Please reference section 4.6 for numbering multiple boxes.
 - b. Option 2: The supplier may have a separate barcode label that identifies the quantity that is in each individual box, but not the total quantity of the shipment on each box.
- 4. The barcode symbology can be either code 39 and/or code 128 for encoding Data Identifiers (DIs). Please note the DI must be part of the encoded barcode.

FROM: ABC Corporation 123 Street Address City, State 12345	TO: Texas Instruments 456 Street Address, Dock XYZ City, State 12345
(14K) PO+Line: 14K4510429339+0010 	
(P) TI P/N: P4041234-0001 	
(Q) Quantity Q25 	
(11K) Delivery Note: 11KINV96001 	
(16D) Prod Date: 16D20050120 	
Part Description Description Line 2 Description Line 3	
PACKAGE COUNT: 1 of 1	PACKAGE WEIGHT: 220 LB 100KG

4.4 Supplier Barcode Data Requirements

1. The following data is required to be contained on the barcode label..
 - a. PO/ Line Item
 - i. Data Identifier is 14K > PO number > + sign > line item i.e.(0010)
 1. EXAMPLE: 14K4510429339+0010
 - b. Quantity
 - i. Data identifier is Q
 1. EXAMPLE: Q25
 - c. Delivery Note
 - i. Data Identifier is 11K
 1. EXAMPLE: 11KINV96001
 - d. TI Part Number
 - i. Data Identifier is P
 1. EXAMPLE: P4041234-0001
 - e. Batch number
 - i. Batch Identifier is LN
 1. EXAMPLE : LNH7671041-0001
 - f. Description : Descriptions are required.

Code Ident 01295	Document number 6512960	Rev M	Sheet 16 of 22
-------------------------	--------------------------------	--------------	----------------

- g. Production Date (for batch controlled materials). Production data is optional.
2. The following table provides more details about each of the fields contained on the label. Do not mix field labels and data on the bar code. Examples: a) If the field label says "Quantity" then data displayed must be the quantity. B) If the field label says "Batch", then the data displayed must be the batch information.

Field	DI	Length	Notes
PO/Line	14K	PO = 10 Line = Max 5	<p>This is the TI PO and line item number. The PO number is required. A TI PO line item number should be provided if possible. The PO line item is required as it specifies exactly the item that TI ordered. The line item is separated from the PO number by a "+" (plus) sign. This allows automatic reading of the PO and the line item by the receiving barcode software.</p> <p>Note: Depending upon the PO, the line item may be a single digit or multiple digits. Do not make the assumption that the first item on the PO has a line item of 1.</p>
TI Part Number	P	7-4 format 12 character's total	<p>This is TI's part number specified on the PO.</p> <p>This is optional; however it is preferred whenever possible for verification of the material name on the PO. The TI part number format is 7-4 numeric characters. i.e., 4030040-0001.</p>
Quantity	Q	Max 17	<p>The shipment must be sent in the same unit of measure as was specified on the PO. This is to remove the complications Associated with receipt of an item that is in a different unit of measure, as dock personnel do not open packages to check or count the contents.</p>
Delivery Note	11K	Max 16	<p>The Delivery Note is a number such as the Packing List Number, Invoice Number or other Reference Number that is used to identify the supplier's shipment. It is used during ERS (Evaluated Receipt Settlement) to "pay on receipt" of the item. This is important as it allows the supplier to be paid in as short a time as possible.</p>

Production Date	16D	8	Production date is requested (not required) to be included in the barcode in the format YYYYMMDD. This is only requested for batch controlled materials (e.g. those items with a shelf life).
Description	None	Max 80	A description of the item is required.
Batch Number	LN	15	This field contains the supplier batch or lot number for the respective shipment if applicable.
Package Count	None		This field contains the package count "Box 1 of n."
Package Weight	None		This field contains the package gross weight in both metric (i.e. kg) and English (i.e. lbs.) units.

4.5 Internal Barcode Generation and Information:

1. All direct materials shipping to any TI Assembly Test (A/T) site are required to comply to the internal barcode label requirements per table 1.0 below. Do not mix labels and data on the barcode (i.e., if the label says "Quantity" then data displayed must be the quantity).

Barcode Requirement	All Substrates	Lead frame	Epoxy	Die Coating	Au Wire	Cu Wire	Mold Cmpd	Solder ball	Solder Paste	Silicon
Part number	Y	Y	Y	Y	Y	Y	Y	Y	Y	N/A
Supplier lot# (Batch number)	Y	Y	Y	Y	Y	Y	Y	Y	Y	N/A
Expiration date	Y	NB	Y	Y	NB	Y	Y	Y	Y	N/A
PO Number	N/A	N/A	N/A	N/A	N/A	N/A	N/A	N/A	N/A	Y
Delivery Note	N/A	N/A	N/A	N/A	N/A	N/A	N/A	N/A	N/A	Y
Manufacturing date	NB	Y	NB	NB	NB	NB	NB	NB	NB	N/A
Coffin ID / Spool ID	Y	NB	NB	NB	NB	Y	NB	NB	NB	N/A
Quantity	Y	NA	NA	NA	NA	NA	NA	NA	NA	Y
Plating Info	NB	NA	NB	NB	NB	NB	NB	NB	NB	N/A

Table 1.0 – Internal Barcode Requirements Table

Legend

- Y - Printed image and barcode required
- NA - Printed image required but barcode is optional. If barcode is included, need to follow the specification requirement/s. For Quantity format requirement refer to section 4.5.9 below.
- NB - Printed image and barcode not required. If barcode is included, need to follow the internal barcode specification requirement/s.

- a. The use of an internal barcode is also highly recommended when shipping raw materials to non-A/T sites in order to identify batch issues more promptly.
2. Internal barcode labels should use Code 39.
 3. Internal barcode labels should not exceed 6cm in length.
 4. Internal barcode labels will have the decoded value located either directly below or directly above the barcode.

5. For the TI Parts Number barcode, the revision letter should not be incorporated in the same barcode as the part number. The revision letter may be added after the part number on the printed image but should NOT be included in the Part Number barcode.
 - a. Format: AAAAAAA-BBBB
 - b. Description: 12-character length including the dash (-) between the 7th and the 8th characters. Characters A and B are both NUMERIC
 - c. Data Example: 4205205-0010
 - d. Label Sample: *4205205-0010*
6. The Part Number printed image is requested to be emphasized with larger fonts as compared to the rest for better visibility. The largest possible font is preferred.
7. Supplier's Lot Number format requirement
 - a. Format: "LN" + Supplier lot number
 - b. Description: Variable length with the prefix "LN" and supplier lot number is alphanumeric characters
 - c. Data Example: LNS07010390
 - d. Label Sample: *LNS07010390*
8. Expiration and Manufacturing Date/s format requirement
 - a. Format: MM/DD/YYYY
 - b. Description: 10-character total length including the slash (/)
 - i. MM = 2 character length indicating the month
 - ii. DD = 2 character length indicating the day
 - iii. YYYY = 4 character length indicating the year
 - c. Data Example: 06/20/2017
 - d. Label Sample: *06/20/2017*
9. Quantity format requirement
 - a. Format: "QY" + quantity
 - b. Description: Variable length with QY prefix; quantity is NUMERIC character and no space between QY and the quantity value. Barcode result should not have comma or k (as 1000). The printed image or text can have a full quantity value, may include 'comma' or k (as 1000) for better human readability.
 - c. Data Example:
 - d. Printed image – QY3000000 or QY3,000,000 or QY3,000k
 - e. Barcode label result – QY3000000
10. Barcode requirement for Cu wire spool ID
 - a. Format: "LN" + Supplier lot number + "-" + serial number
 - b. Description: Variable length with the prefix "LN" and Supplier lot number is alphanumeric character plus the spool serial number. The spool serial number should not be repeated for the same supplier lot number regardless of different shipment timing.
 - c. Example: Suppose the supplier lot number is H7671041

Shipment 1

Spool 1 lot no = LNH7671041-001
 Spool 2 lot no = LNH7671041-002
 Spool 3 lot no = LNH7671041-003

Shipment 2 (Shipment 2 CANNOT repeat shipment 1 lot number)

Spool 1 lot no = LNH7671041-004
 Spool 2 lot no = LNH7671041-005
11. Barcode requirement for Substrates
 - a. The quantity must have the prefix "QY"

Actual Quantity	Barcode result	Printed Image
3,000	QY3000	QY3000, QY3,000 or QY3k
3	QY3 (not QY003, QY03)	QY3

12. Coffin ID

- a. Format: "DN" + Supplier lot number + Suffix
- b. Description: Maximum length is 15 characters including the prefix and suffix. The suffix is incremented based on the coffin #

Coffin #	Suffix
1	AA
2	AB
3	AC
:	:
26	AZ
27	BA
:	:

4.6 Box Numbering

- 1. When dealing with multiple boxes, each box should be individually numbered as a section of the total (i.e. If there are 12 total boxes, each box will be identified 1 of 12, 2 of 12...11 of 12, 12 of 12).

5 - Packing List

5.1 General

One legible packing list, preferably machine-generated, is required for each shipment, or one packing list is required for each case number, except when shipping multiple cases of the same part number.

All packing lists must contain the following information:

- 1. Shipper's name and full address (including country if export)
- 2. TI part number(s) in numerical sequence and Export Control number (if applicable)
- 3. PO Number (if applicable)
- 4. Notify Party
- 5. Receiving location's name and full address
- 6. Number and type of pieces shipped
- 7. Cargo gross weight (kilograms)
- 8. Description of material (clear descriptions that are not vague or including industry jargon)
- 9. Ship date
- 10. Container number and seal number (if applicable)
- 11. Supplier packing list number (if applicable)
- 12. A duplicate of the barcoded shipment label
- 13. Country of origin (as defined on page & origin)
- 14. UN code for dangerous goods (where applicable)

5.2 Packing List Placement

- 1. It is highly recommended that the packing list is placed on the **outside** of a container or pallet load – it must be attached to a vertical side, near the top, but not on top and securely affix with a transparent envelope or tape so the packing list is visible and protected from damage.
- 2. If the packing list is placed **inside** the container – only under circumstances that the packing list on the exterior has a relatively high risk of being lost during transport – that container must be identified with a "**Packing List Enclosed**" label or marking which is easily seen; place in container 1.

3. Place all paperwork/documents (e.g. certificate of compliance, certificate of approval, etc) in the same envelope as the packing list. NOTE: Documents may also require electronic submission per TI purchasing requirements.

Code Ident 01295	Document number 6512960	Rev M	Sheet 21 of 22
-------------------------	--------------------------------	--------------	----------------

Revision	Description
A	ECO #2101846, M. Murray, 10/02/09, Steve Yager: Formal release
B	ECO #2111234, M. Murray, 11/03/10, S. Yager/Chris Durant; Minor clarifications within capital equipment crating section, Revised Sec 6.1.10, Removed Sec 6.6 Ocean Shipment Procedures per standalone document release, and added 6-12 month and >12 month # of desiccant units to chart in Sec 6.3
C	ECO #2115882, M. Murray, 05/16/11, S. Yager: 1) TI Branded formatting added, 2) Added minimum package size under Sec 2.4, 3) Removed unnecessary contents header 6.6, 4) Revised packing list requirements under Sec 5.1, 5) Removed verbage, "Loads Which Provide a Flush Top Surface By Assembling Empty Cartons" on page 9, 6) Sec 4.4.2 – Production Date notes edited to be a request vs requirement, 7) Sec 4.4.2 – Delivery Note data identifier now allows "11K" or "1P", 8) Sec 4.5.6 revised to read "requested to" instead of "should be", 9) Sec 2.4 and Diagrams – Palletize shipments >27kgs or 60lbs, 10) Sec 3.1.1 added – Pallet material requirements, 11) Sec 3.5 – Revised acceptable standard pallet dimensions, 12) Sec 6.1.6 – Defined crate floating base thickness and material requirements, 13) Sec 6.5 – Crating Compliance Checklist and diagram added
D	ECO #2118624, M. Murray, 09/14/11, S. Yager – Add Sec 6.5 Crating Compliance Checklist, Update wording throughout document
E	ECO #2121817, 01/25/12, M. Murray, Steve Yager ; 1) Index updated, 2) Sec 2.1.4 minimum size shipments updated, 3) Added Sec 6.5, "Factory Loading" of ocean container by shipper, 4) Sec 4.4 package "gross" weight, 5) Sec 7, Added Global Lithium Ion Battery shipment requirements, 6) Revised Crating Compliance Checklist on page 23 & 24
F	ECO #2125590, 06/29/12, M. Murray, Mark Boado; Revision Crating Compliance Checklist comprehending additional 2 parameters.
G	ECO #2135077, 08/05/13, M. Murray, Barbara Daniels; Added clarifications to sections 2.1.4, 4.4.2 and 4.5.1.
H	ECO #2137565, 11/13/13, M. Murray, Chris Durant; 1) Update desiccant requirements in Section 6.3, 2) Update Section 7
I	ECO #2150273, 4/18/15, MJ Esteban, Perry Shields; add parag 2.5, 3.7
J	ECO #2156089, 02/16/16, Chris Durant; Update Sections 6.1.9 through 6.1.17, 6.2.1 through 6.2.3 and Crating Compliance Checklist on sheet 30
K	ECO #2157836, 04/29/16, W. Nisperos, remove equipment crating section.
L	ECO #2174045, 05/02/18, W. Nisperos, update labeling specification
M	ECO #2177360, 10/31/18, W. Nisperos; 1) Update parag 3.7.4 2) Update for data fields to include supplier batch/lot number in 4.1.