

TFC 45 | SUPER STACKER



TFC 45 / TFC 45 R / TFC 45 RX / TFC 45 RS / TFC 45 L / TFC 45 LS / TFC 45 LX / TFC 45 LSX

# SUPER STACKER<sup>h/hc</sup>

		TFC 45	TFC 45 R	TFC 45 RX	TFC 45 RS	TFC 45 L	TFC 45 LS	TFC 45 LX	TFC LSX
<b>TRANSLATION</b>									
Vitesse AV/AR	A vide	25 Km/h	25 Km/h	25 Km/h	25 Km/h	25 Km/h	25 Km/h	25 Km/h	25 Km/h
	En charge 45 t	25 Km/h	25 Km/h	25 Km/h	25 Km/h	25Km/h	25 Km/h	25 Km/h	25 Km/h
Rampe franchissable maxi	A vide	41%	40%	36%	38%	38%	37%	37%	35%
	En charge 45 t	25%	24%	22%	23%	23%	22,30%	22,30%	20,80%
<b>Effort de traction</b>		<b>28,9 t</b>	<b>28,9 t</b>	<b>28,9 t</b>	<b>28,9 t</b>	<b>28,9 t</b>	<b>28,9 t</b>	<b>28,9 t</b>	<b>28,9 t</b>
<b>POIDS AVEC PALONNIER STANDARD</b>									
A vide avec flèche baissée	Pont A V	37,4 t	35,8 t	37,6 t	38,5 t	36,6 t	38 t	43,8 t	42,6 t
	Essieu AR	31,2 t	37,3 t	41,2 t	38 t	38,8 t	38,4 t	41,9 t	41,8 t
	<b>Total</b>	<b>68,6 t</b>	<b>73,1 t</b>	<b>78,8 t</b>	<b>76,5 t</b>	<b>75,4 t</b>	<b>76,4 t</b>	<b>85,7 t</b>	<b>84,4 t</b>
En charge 45t et en translation avec angle flèche :		45°	45°	45°	45°	40°	40°	40°	40°
	Pont A V	87,9 t	87,6 t	87,8 t	88,6 t	82,9 t	84,3 t	91,4 t	92,2 t
	Essieu AR	25,7 t	30,5 t	36 t	32,8 t	37,5 t	37,1 t	39,3 t	37,2 t
	<b>Total</b>	<b>113,6 t</b>	<b>118,1 t</b>	<b>123,8 t</b>	<b>121,4 t</b>	<b>120,4 t</b>	<b>121,4 t</b>	<b>130,7 t</b>	<b>129,4 t</b>
En statique, levage 45 t en 1 R	Pont A V	96,8 t	96,5 t	96,8 t	97,6 t	95,8 t	97,2 t	103,2 t	104 t
	Essieu AR	16,8 t	21,5 t	27 t	23,8 t	24,6 t	24,2 t	27,5 t	25,4 t
	<b>Total</b>	<b>113,6 t</b>	<b>118,1 t</b>	<b>123,8 t</b>	<b>121,4 t</b>	<b>120,4 t</b>	<b>121,4 t</b>	<b>130,7 t</b>	<b>129,4 t</b>
<b>FLECHE</b>									
Télescopage sortie									
	A vide, version h	23 sec. 0,31 m/s	23 sec. 0,31 m/s	23 sec. 0,31 m/s	23 sec. 0,31 m/s				
	A vide version hc	16 sec. 0,44 m/s	16 sec. 0,44 m/s	16 sec. 0,44 m/s	16 sec. 0,44 m/s	16 sec. 0,44 m/s	16 sec. 0,44 m/s	14 sec. 0,44 m/s	14 sec. 0,44 m/s
	En charge 30 t	23 sec. 0,31 m/s	23 sec. 0,31 m/s	23 sec. 0,31 m/s	23 sec. 0,31 m/s	23 sec. 0,31 m/s	23 sec. 0,31 m/s	20 sec. 0,31 m/s	20 sec. 0,31 m/s
Télescopage rentrée	A vide	18 sec. 0,40 m/s	18 sec. 0,40 m/s	18 sec. 0,40 m/s	18 sec. 0,40 m/s	18 sec. 0,40 m/s	18 sec. 0,40 m/s	16 sec. 0,40 m/s	16 sec. 0,40 m/s
	En charge 30 t	17 sec. 0,41 m/s	17 sec. 0,41 m/s	17 sec. 0,41 m/s	17 sec. 0,41 m/s	17 sec. 0,41 m/s	17 sec. 0,41 m/s	15 sec. 0,41 m/s	15 sec. 0,41 m/s
Relevage montée de 0° à 60°	A vide, version h	22 sec.	22 sec.	22 sec.	22 sec.				
	A vide version hc	16 sec	16 sec	16 sec	16 sec	16 sec	16 sec	16 sec	16 sec
	En charge 30 t	18 sec	18 sec	18 sec	18 sec	25 sec.	25 sec.	25 sec.	25 sec.
Relevage descente de 60° à 0°	A vide	21 sec.	21 sec.	21 sec.	21 sec.	21 sec.	21 sec.	21 sec.	21 sec.
	En charge 30 t	14 sec.	14 sec.	14 sec.	14 sec.	14 sec.	14 sec.	14 sec.	14 sec.
Elévation du conteneur jusqu'en 5 <sup>ème</sup> hauteur (4 <sup>ème</sup> pour LX, LSX) en mouvements combinés	A vide, version h	40 sec. 0,34 m/s	40 sec. 0,34 m/s	40 sec. 0,34 m/s	40 sec. 0,34 m/s				
	A vide version hc	35 sec 0,40m/s	35 sec 0,40m/s	35 sec 0,40m/s	35 sec 0,40m/s	35 sec 0,40m/s	35 sec 0,40m/s	28 sec 0,40m/s	28 sec 0,40m/s
	En charge 30 t	45 sec. 0,26 m/s	45 sec. 0,26 m/s	45 sec. 0,26 m/s	45 sec. 0,26 m/s	45 sec. 0,26 m/s	45 sec. 0,26 m/s	33 sec. 0,26 m/s	33 sec. 0,26 m/s
Descente du conteneur de 5 <sup>ème</sup> hauteur (4 <sup>ème</sup> pour LX, LSX) au sol, en mouvements combinés	A vide	25 sec. 0,55 m/s	25 sec. 0,55 m/s	25 sec. 0,55 m/s	25 sec. 0,55 m/s	25 sec. 0,55 m/s	25 sec. 0,55 m/s	21 sec. 0,55 m/s	21 sec. 0,55 m/s
	En charge 30 t	23 sec. 0,5 m/s	23 sec. 0,5 m/s	23 sec. 0,5 m/s	23 sec. 0,5 m/s	23 sec. 0,5 m/s	23 sec. 0,5 m/s	18 sec. 0,5 m/s	18 sec. 0,5 m/s

\* La version " hc " est en standard sur les machines L, LS,LX and LSX

<b>MOTEUR</b>	Conforme normes antipollution CE et E.P.A	
Marque / type	Cummins / QSM11	
Refroidissement	Par eau	
Carburant	Fioul	
Principe	4 temps, 6 cylindres en ligne suralimenté par turbocompresseur	
Puissance	SAE J 1995/ ISO 3046 / DIN 6271	Maxi : 320 CV (239 kW) à 1800 tr/mn Nominale: 290 CV (216 kW) à 2100 t/mn
Couple maxi à 1400 t/mn	SAE J 1995/ ISO 3046/ DIN 6271	1478 Nm
Cylindrée	10,82 L	
Alternateur (marque / type)	Delco-Rémy - 70 A - 24 V	
Démarrreur (marque / type)	Delco-Rémy 39 MT HD - 400 Ampères - 24 V	
Batterie (voltage / capacité)	2 x 12 V - 200 Ah	
Consommation de combustible	15 à 18 l/ h	

<b>BOITE DE VITESSES</b>		
Marque / type	Dana (Clark) / TE 27 418	
Embrayage	Par convertisseur de couple - R = 2,292	
Type de boîte	Automatic Powershift Control / APC 200	
Nombre de vitesses A V / AR	4/4	
Rapport de vitesses A V / AR	5,07 / 2,42/ 1,38 / 0,78	

<b>PONT A V</b>		
Principe	Pont moteur double réduction avec freins à disque à bain d'huile	
Rapport de réduction	25,40 ou 22,6	

<b>ESSIEU AR</b>		
Principe	Essieu directeur oscillant	

<b>PNEUMATIQUES</b>		
Dimensions	Tubeless 18.00 x 25 ou 18.00 x 33 ou 21.00 x 25	
Pression : (1 bar = 1 kg/cm <sup>2</sup> )	10 bars (7,5 bars pour 2100 x 25)	

<b>SYSTEME DE DIRECTION</b>		
Principe	Hydrostatic avec un vérin double effet sur essieu arrière	

<b>FREINAGE</b>		
Type	Freins multi disques à bain d'huile sur pont A V	
Commande	Hydraulique	
Frein de parc	Disque sur nez de pont, action par ressorts	

<b>HYDRAULIQUE</b>		
Circuit principal	Système Load Sensing	
Pompe principale	Double pompe à pistons à débit variable 145+75 cc Débit 460 l/mn - Pression maximum 350 bars	
Commandes	Un manipulateur hydraulique en croix pour relevage, télescopage, rotation et chariotage du palonnier	
Pompes auxiliaires	Ventilo réfrigérant moteur et transmission Filtration et refroidissement circuit hydraulique Alimentation refroidissement freins Pilotage manipulateur hydraulique	Pompe à cylindrée variable de 28 cc - 58 l/mn Pompe à engrenages de 40 cc - 82 l/mn Pompe à engrenages 12 cc - 25 l/mn Pompe à engrenages 8 cc - 16 l/mn

<b>CAPACITES</b>		
Réservoir de carburant	520 L	
Réservoir hydraulique	750 L	
Système de refroidissement	70 L	
Pont A V	94 L	
Boîte de vitesses	70 L	
Moteur	35 L	

<b>CABINE</b>		
Dimension	Cabine large de série	Larg = 1730, prof = 1370, haut = 1485 (dimensions intérieures en mm)
Niveau sonore	72 dba portes fermées	
Climatisation	De série	

<b>MAINTENANCE</b>		
Auto diagnostic	Version "h" : moteur, boîte de vitesses, général machine Version "hc" : moteur, boîte de vitesses, hydraulique, général machine	

<b>SECURITE</b>		
Antibascullement	Coupure automatique des mouvements dangereux en cas de surcharge	
Controleur d'état de charge	En option en version "h" - De série en version "hc"	
Moteur	Mise en sécurité automatique en cas de détection défaut niveau ou pression d'huile, température circuit refroidissement ou air turbo	

		TFC 45	TFC 45 R	TFC 45 RX	TFC 45 RS	TFC 45 L	TFC 45 LS	TFC 45 LX	TFC LSX
<b>TRANSLATION</b>									
Speed FWD/REW	No load	25 Km/h	25 Km/h	25 Km/h	25 Km/h	25 Km/h	25 Km/h	25 Km/h	25 Km/h
	With 45 t load	25 Km/h	25 Km/h	25 Km/h	25 Km/h	25Km/h	25 Km/h	25 Km/h	25 Km/h
Max gradeability	No load	41%	40%	36%	38%	38%	37%	37%	35%
	45 t full load	25%	24%	22%	23%	23%	22,30%	22,30%	20,80%
<b>Towing ability</b>	<b>28,9 t</b>	<b>28,9 t</b>	<b>28,9 t</b>	<b>28,9 t</b>	<b>28,9 t</b>	<b>28,9 t</b>	<b>28,9 t</b>	<b>28,9 t</b>	<b>28,9 t</b>
<b>WEIGHT WITH TOP-PICK SPREADER</b>									
No load - boom down									
	Front axle	37,4 t	35,8 t	37,6 t	38,5 t	36,6 t	38 t	43,8 t	42,6 t
	Rear axle	31,2 t	37,3 t	41,2 t	38 t	38,8 t	38,4 t	41,9 t	41,8 t
	<b>Total</b>	<b>68,6 t</b>	<b>73,1 t</b>	<b>78,8 t</b>	<b>76,5 t</b>	<b>75,4 t</b>	<b>76,4 t</b>	<b>85,7 t</b>	<b>84,4 t</b>
45T full load travelling with angle boom :									
	45°	45°	45°	45°	40°	40°	40°	40°	40°
	Front axle	87,9 t	87,6 t	87,8 t	88,6 t	82,9 t	84,3 t	91,4 t	92,2 t
	Rear axle	25,7 t	30,5 t	36 t	32,8 t	37,5 t	37,1 t	39,3 t	37,2 t
	<b>Total</b>	<b>113,6 t</b>	<b>118,1 t</b>	<b>123,8 t</b>	<b>121,4 t</b>	<b>120,4 t</b>	<b>121,4 t</b>	<b>130,7 t</b>	<b>129,4 t</b>
Static - 45 T full load - 1st row									
	Front axle	96,8 t	96,5 t	96,8 t	97,6 t	95,8 t	97,2 t	103,2 t	104 t
	Rear axle	16,8 t	21,5 t	27 t	23,8 t	24,6 t	24,2 t	27,5 t	25,4 t
	<b>Total</b>	<b>113,6 t</b>	<b>118,1 t</b>	<b>123,8 t</b>	<b>121,4 t</b>	<b>120,4 t</b>	<b>121,4 t</b>	<b>130,7 t</b>	<b>129,4 t</b>
<b>BOOM</b>									
Telescoping out									
	No load, " h " version	23 sec. 0,31 m/s	23 sec. 0,31 m/s	23 sec. 0,31 m/s	23 sec. 0,31 m/s				
	No load, " hc " version	16 sec. 0,44 m/s	16 sec. 0,44 m/s	16 sec. 0,44 m/s	16 sec. 0,44 m/s	16 sec. 0,44 m/s	16 sec. 0,44 m/s	14 sec. 0,44 m/s	14 sec. 0,44 m/s
	30 t load	23 sec. 0,31 m/s	23 sec. 0,31 m/s	23 sec. 0,31 m/s	23 sec. 0,31 m/s	23 sec. 0,31 m/s	23 sec. 0,31 m/s	20 sec. 0,31 m/s	20 sec. 0,31 m/s
Telescoping in									
	No load	18 sec. 0,40 m/s	18 sec. 0,40 m/s	18 sec. 0,40 m/s	18 sec. 0,40 m/s	18 sec. 0,40 m/s	18 sec. 0,40 m/s	16 sec. 0,40 m/s	16 sec. 0,40 m/s
	30 t load	17 sec. 0,41 m/s	17 sec. 0,41 m/s	17 sec. 0,41 m/s	17 sec. 0,41 m/s	17 sec. 0,41 m/s	17 sec. 0,41 m/s	15 sec. 0,41 m/s	15 sec. 0,41 m/s
Hoisting up from 0° to 60°									
	No load, " h " version	22 sec.	22 sec.	22 sec.	22 sec.				
	No load, " hc " version	16 sec	16 sec	16 sec	16 sec	16 sec	16 sec	16 sec	16 sec
	30 t load	18 sec	18 sec	18 sec	18 sec	25 sec.	25 sec.	25 sec.	25 sec.
Hoisting down from 60° to 0°									
	no load	21 sec.	21 sec.	21 sec.	21 sec.	21 sec.	21 sec.	21 sec.	21 sec.
	30t load	14 sec.	14 sec.	14 sec.	14 sec.	14 sec.	14 sec.	14 sec.	14 sec.
Time to stack a container from 1 <sup>st</sup> height to 5 <sup>th</sup> height (4 <sup>th</sup> for LX, LSX) simultaneous functions									
	No load, " h " version	40 sec. 0,34 m/s	40 sec. 0,34 m/s	40 sec. 0,34 m/s	40 sec. 0,34 m/s				
	No load, " hc " version	35 sec 0,40m/s	35 sec 0,40m/s	35 sec 0,40m/s	35 sec 0,40m/s	35 sec 0,40m/s	35 sec 0,40m/s	28 sec 0,40m/s	28 sec 0,40m/s
	30 t load	45 sec. 0,26 m/s	45 sec. 0,26 m/s	45 sec. 0,26 m/s	45 sec. 0,26 m/s	45 sec. 0,26 m/s	45 sec. 0,26 m/s	33 sec. 0,26 m/s	33 sec. 0,26 m/s
Time to unstack a container from 5 <sup>th</sup> (4 <sup>th</sup> for LX, LSX) height to 1 <sup>st</sup> height (simultaneous functions)									
	no load	25 sec. 0,55 m/s	25 sec. 0,55 m/s	25 sec. 0,55 m/s	25 sec. 0,55 m/s	25 sec. 0,55 m/s	25 sec. 0,55 m/s	21 sec. 0,55 m/s	21 sec. 0,55 m/s
	30 t load	23 sec. 0,5 m/s	23 sec. 0,5 m/s	23 sec. 0,5 m/s	23 sec. 0,5 m/s	23 sec. 0,5 m/s	23 sec. 0,5 m/s	18 sec. 0,5 m/s	18 sec. 0,5 m/s

\* The " hc " version is included in the standard machine for L, LS,LX and LSX

<b>ENGINE</b>	In accordance with EC and E.P.A regulation	
Make	Cummins / QSM11	
Cooling system	Water cooled	
Fuel	Diesel	
Type	4 stroke, inline 6 cylinders, turbocharged	
Power	SAE J 1995/ ISO 3046 / DIN 6271	Maxi : 320 HP (239 kW) at 1800 rpm Rated : 290 HP (216 kW) at 2100 rpm
Max torque at 1400 rpm	SAE J 1995/ ISO 3046/ DIN 6271	1478 Nm
Displacement	10,82 L	
Alternator	Delco-Rémy - 70 A - 24 V	
Starter	Delco-Rémy 39 MT HD - 400 Ampères - 24 V	
Batteries	2 x 12 V - 200 Ah	
Fuel consumption	From 15 to 18 l/ h	

<b>TRANSMISSION</b>		
Make	Dana (Clark) / TE 27 418	
Clutch type	Torque converter - R = 2,292	
Transmission type	Automatic Powershift Control / APC 200	
Gears FWD / REV	4/4	
Gears ration FWD and REV	5,07 / 2,42/ 1,38 / 0,78	

<b>FRONT AXLE</b>		
Type	Drive axle - Double reduction with wet disc brakes	
Reduction	25,40 or 22,6	

<b>REAR AXLE</b>		
Description	Heavy duty oscillating axle	

<b>TYRES</b>		
Dimensions	Tubeless 18.00 x 25 or 18.00 x 33 or 21.00 x 25	
Pressure : (1 bar = 1 kg/cm <sup>2</sup> )	10 bars (7,5 bars for 2100 x 25)	

<b>STEERING</b>		
Description	Hydrostatic rear steering with double acting cylinder	

<b>BRAKING</b>		
Type	Wet disc brakes on front axle by independant hydraulic circuit	
Control	Hydraulic	
Parking brake	Spring release disc on the front axle	

<b>HYDRAULIC</b>		
Main system	Power regulated Load Sensing	
Main pump	Two section variable displacement - piston pump 145+75 cc Flow 460 l/mn - Maximum pressure 350 bars	
Controls	One hydraulic joystick. Boom hoist and telescoping Spreader rotation - Side shift	
Auxiliary	Engine and transmission cooler	Variable displacement pump 28 cc - 58 l/mn
	Hydraulic cooler and filtration	Gear pump 40 cc - 82 l/mn
	Braking axle oil cooler	Gear pump 12 cc - 25 l/mn
	Joystick control	Gear pump 8 cc - 16 l/mn

<b>CAPACITIES</b>		
Fuel	520 L	
Hydraulic oil	750 L	
Cooling system	70 L	
Drive axle	94 L	
Transmission	70 L	
Engine	35 L	

<b>CAB</b>		
Dimension	Wide cab in standard	Wide = 1730, deep =1370, high = 1485 (inside dimensions in mm)
Sound level	72 dba closed doors	
Air conditioning	In standard	

<b>MAINTENANCE</b>		
Auto diagnosis	"h" version : engine, transmission, general machine "hc" version : engine, transmission, hydraulic, general machine	

<b>SECURITY</b>		
Anti tipping device	Automatic cut-off system in case of overload	
Load moment indicator	In option with "h" version, in standard with "hc" version	
Engine	Protection device (reducing engine revolutions and power output) on set parameters for : oil temperature, coolant temperature, turbo inlet air temperature and maximum engine revolutions	

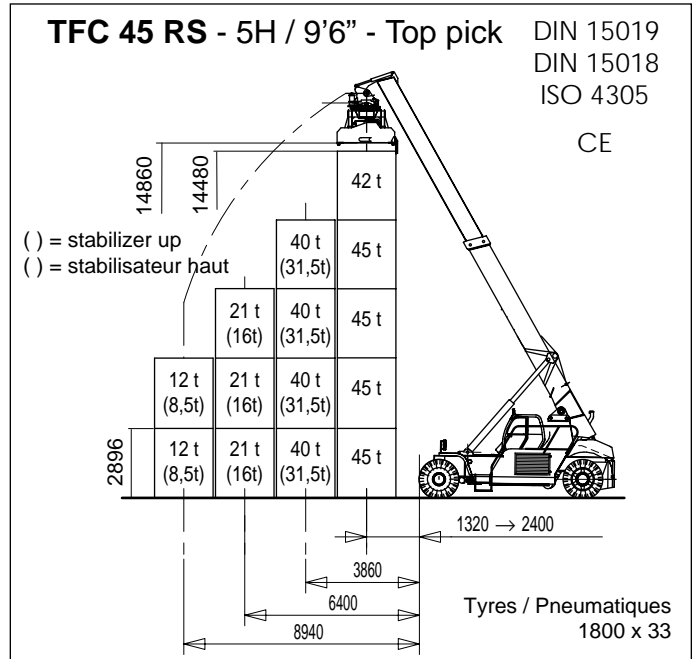
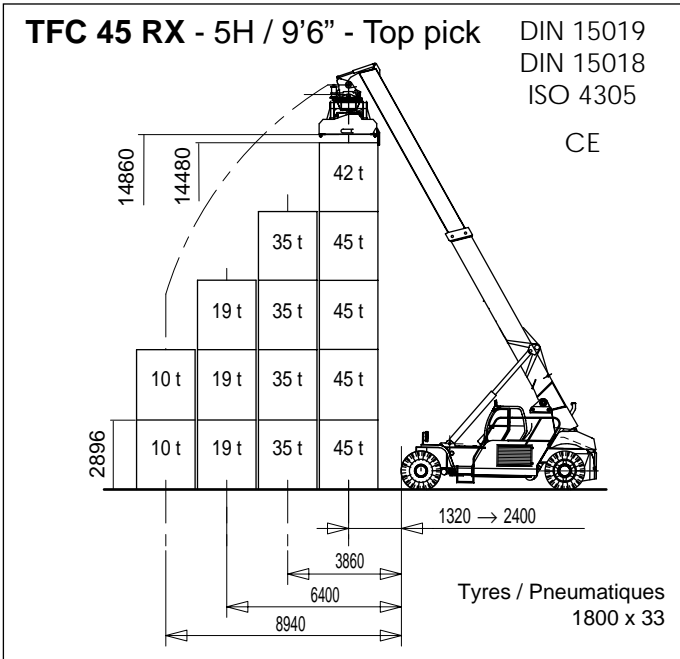
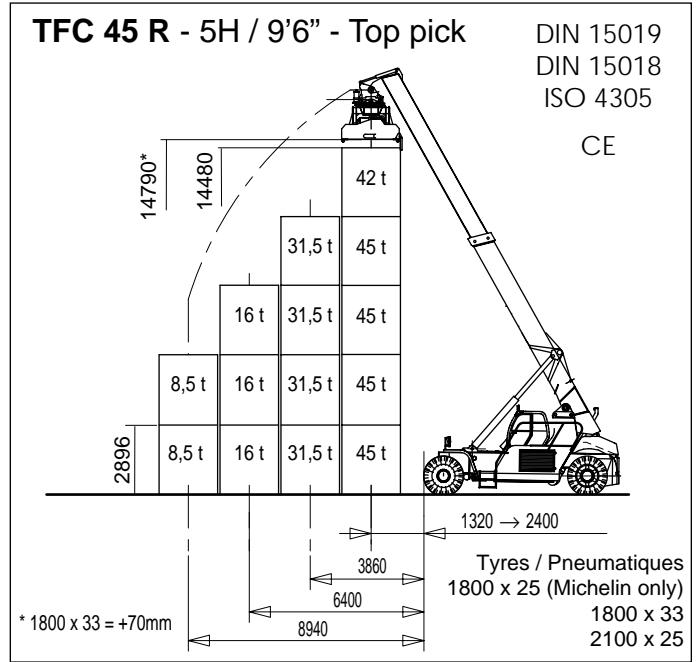
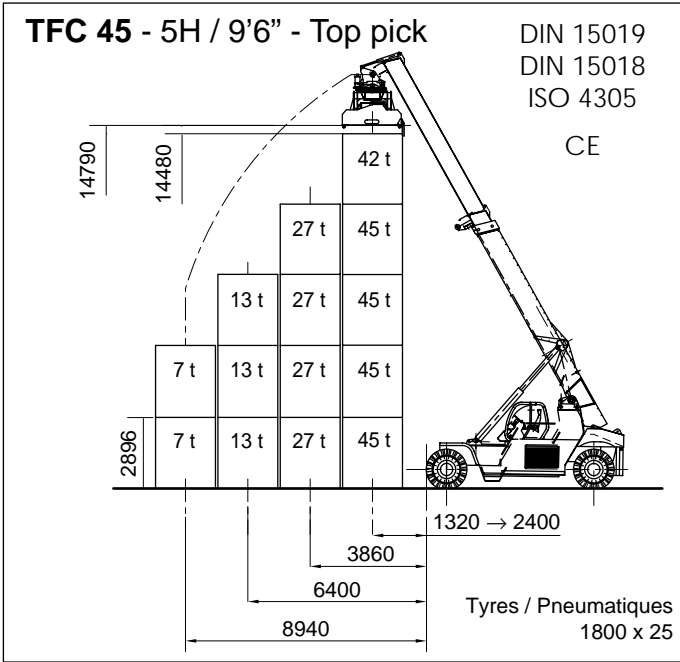

**RAYONS DE BRAQUAGE  
TURNING RADIUS**

	40'		20'	
	A	R1	A	R2
TFC 45	12830	10418	10205	8785
TFC 45 R				
TFC 45 RX				
TFC 45 RS				
TFC 45 L	12964	11196	11445	10100
TFC 45 LS				
TFC 45 LX	13837	11311	12365	10100
TFC 45 LSX				

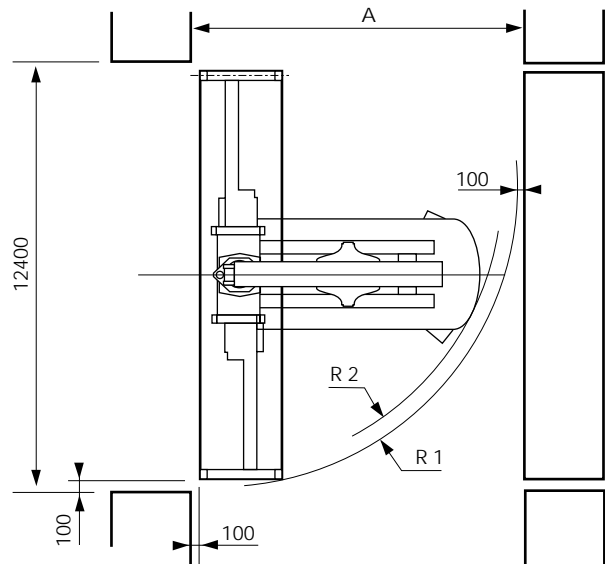

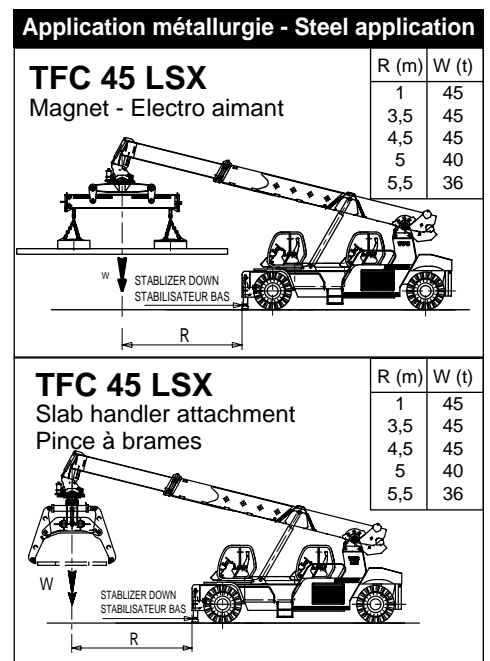
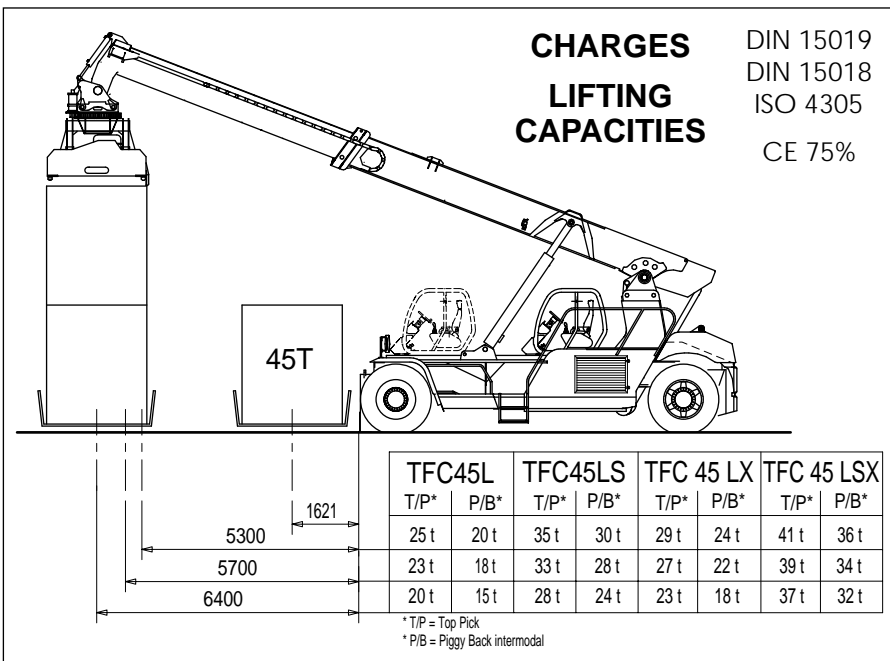
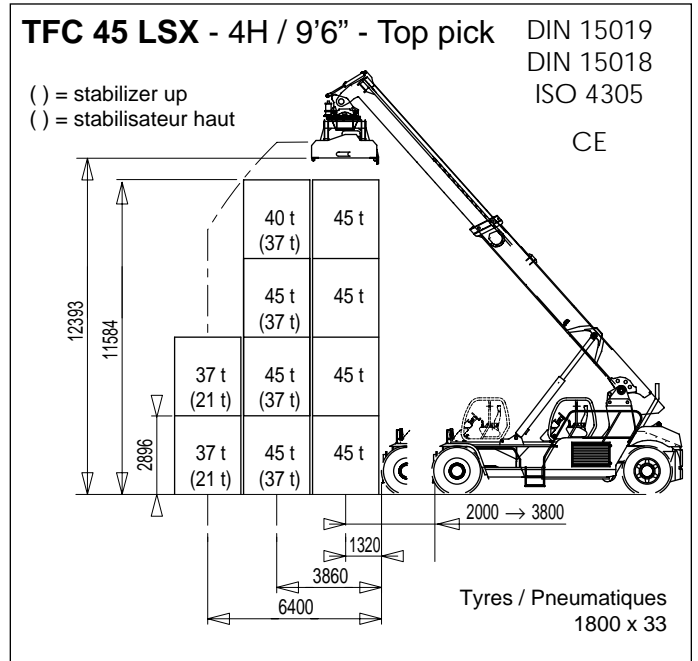
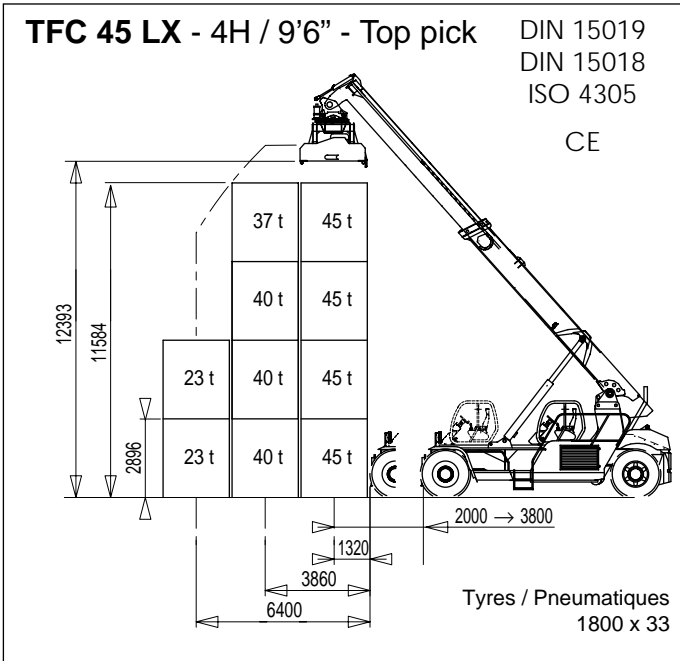
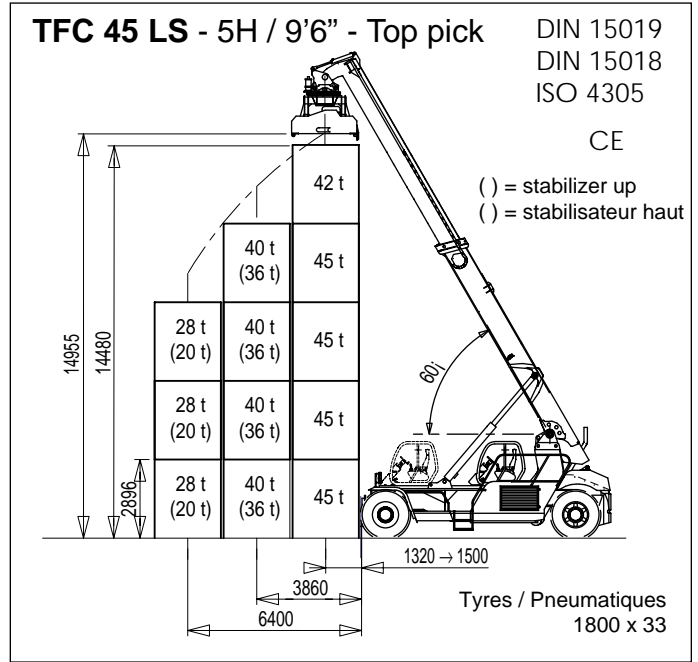
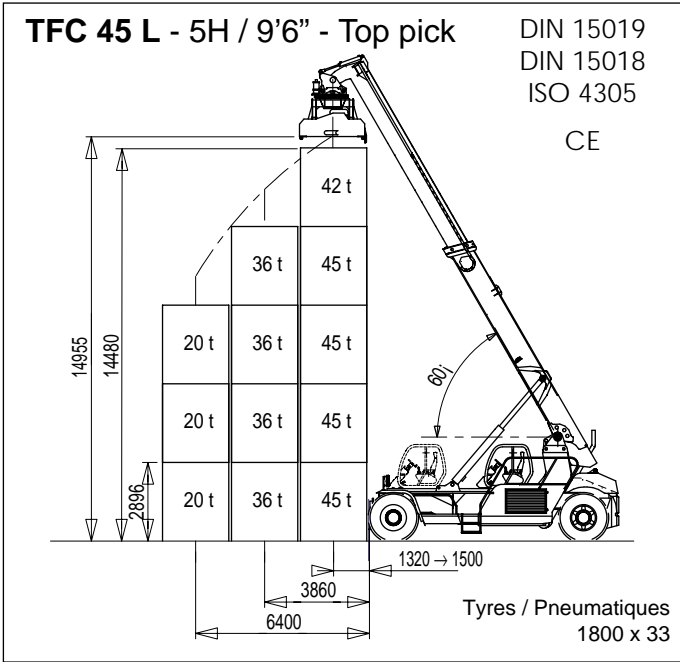

### **Robustesse , Fiabilité**

Présents sur les 5 continents, nos porte conteneurs sont toujours prêts à relever les challenges les plus difficiles.

25 années d'expérience, nous ont permis de sélectionner et de concevoir les composants les plus aptes à garantir la satisfaction de nos Clients. Nos porte conteneurs sont contrôlés et testés dans les conditions les plus sévères.

Installez vous aux commandes d'un Super Stacker , entrez dans un univers de confiance où vous pourrez vous concentrer sur vos manutentions.

### **Hard-wearing and long-lasting**

Our container handlers are always on hand, ready to take up the harshest challenges on all 5 continents.

We can draw on our 25 years of experience to select or design the right components that are guaranteed to satisfy our customers' requirements. Our container handlers are checked and tested to the most stringent criteria.

When you take hold of the controls on a Super Stacker, you can feel the confidence take hold of you, leaving you free to concentrate on the handling manoeuvres.



### **Sécurité anti-basculement**

Pour éviter le risque de basculement, le système de détection de surcharge , situé au niveau de l'essieu arrière, interdit automatiquement les fonctions qui augmentent la portée (télescopage sortie et relevage descente).

### **Anti-tipping system**

An overload sensor on the rear axle prevents tipping by automatically shutting down those functions that increase the radius (telescoping out and lowering).

### **Essieu arrière oscillant**

Les possibilités d'oscillation de l'essieu assurent la stabilité latérale sur tous les types de surface. Un vérin de direction à double effet permet d'obtenir des rayons de braquage réduit.



### **Oscillating rear axle**

The oscillating rear axle guarantees excellent stability on all ground conditions. The double-action steering cylinder gives a low turning radius.

### **Visibilité arrière**

Obtenu grâce à une forme optimisée du contre-poids, le champ de vision , large et dégagé, accroît la sécurité du personnel lors des déplacements.

### **Clear rear visibility**

The shape of the counterweight was optimised to offer a wide and unhindered view and increased safety for personnel during travel.





### **Inclinaison palonnier.**

Lorsque l'inclinaison naturelle du palonnier ne suffit pas, la sélection en mode verrouillage facilite les préhensions difficiles.

### **Spreader tilt angle**

Difficult gripping manoeuvres can be made easier by selecting the damping system while in lock mode if the natural slope of the spreader is not enough.

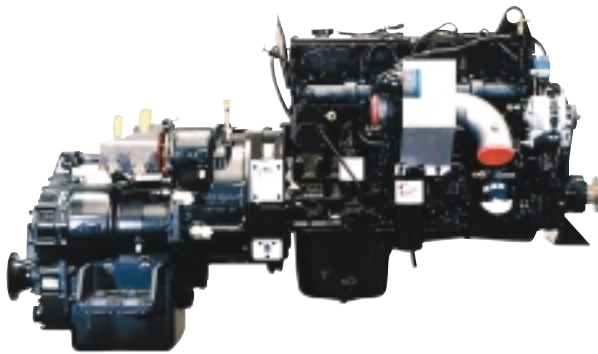

### **Motorisation**

Le moteur de 239 kW, délivrant un couple élevé à bas régime (1478 Nm à 1400 tr/mn ) confère au Super Stacker un rendement optimal pour une consommation réduite.

Son système de gestion intègre une protection automatique du moteur.

### **Drive**

The 239 kW high torque/low rpm engine (1,478 Nm at 1,400 rpm) ensures that the Super Stacker combines maximum power with low fuel consumption.

Its management system includes an automatic engine safety programme.

### **Verrouillage des conteneurs**

Conçus pour un usage intensif et situés en intérieur du cadre du palonnier, les mécanismes sont parfaitement protégés des chocs éventuels et des intempéries.

Pour une sécurité totale, lors des préhensions, notre système de détection interdit les erreurs de verrouillage

### **Container locking**

The locking mechanisms are designed for intensive use and are positioned in the spreader frame for full protection from impacts and foul weather.

Our detection system prevents locking errors during the locking action to give all-round operational safety.



### **Maintenance**

Le système d'auto-diagnostic associé à une parfaite accessibilité des principaux organes vous assurent des immobilisations minimum lors des opérations de maintenance.

### **Maintenance**

The self-diagnosis system and easy access to the main components ensure minimum downtime during maintenance work.

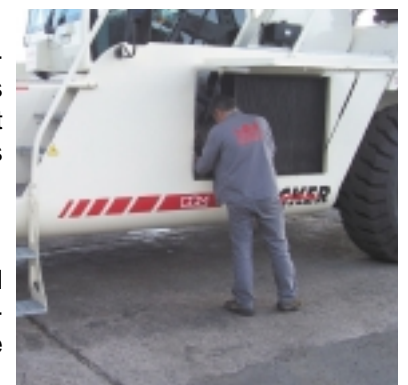

### Cabine

Équipée d'un siège réglable à amortisseur pneumatique, la cabine spacieuse, climatisée et insonorisée confère un confort optimal à l'utilisateur.

Pour une protection totale et une maintenance aisée, les composants électriques sont situés en cabine dans un compartiment spécifique.



### Cab

The spacious air-conditioned and soundproofed cabin also includes an adjustable, air-cushioned seat to give maximum operator comfort.

The in-cab electrical components have all been placed in their own compartment for complete protection and ease of maintenance.

### Instrumentation

Simple et convivial, le tableau de bord offre une vision immédiate aux informations essentielles à l'utilisateur

### Clear instrumentation

A quick scan of the instrument panel clearly reveals vital information at a glance.



## VERSION HC

Répondant aux exigences particulières, nous avons conçu un niveau de finition haut confort ("hc"). Cette version intègre en plus de la finition standard "h", les équipements suivants :

In response to specific requests, we have developed this refined, high comfort ("hc") version, which brings the following equipment to the standard "h" version:

- Contrôleur d'état de charge
- Système de régénération pour des vitesses de levage maximum
- Progressivité et amortissement des fonctions relevage et télescopage de la flèche.
- Compteur de conteneurs
- Verrouillage automatique des conteneurs
- Arrêt automatique à 30' du télescopage spreader
- Auto radio CD
- Auto diagnostic du système hydraulique



- Load moment indicator
- Regeneration system for higher lifting speed
- Flexibility and damping of movements hoisting and telescoping functions
- Container counter
- Automatic twist lock on the spreader
- 30' automatic stop spreader
- Auto radio CD
- Auto diagnosis for hydraulic maintenance.

*Remarque : Le niveau de finition "hc" est en standard sur les modèles L, LS, LX, LSX*

*NB: the "hc" finish is applied as standard to L, LS, LX and LSX models.*

**TFC 45 - R - RX - RS**

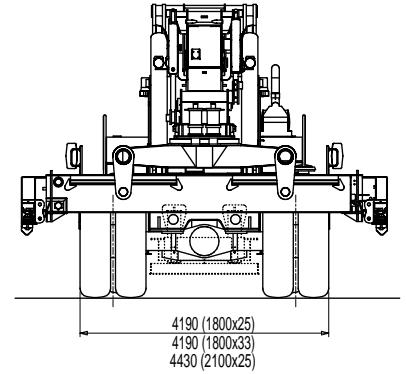
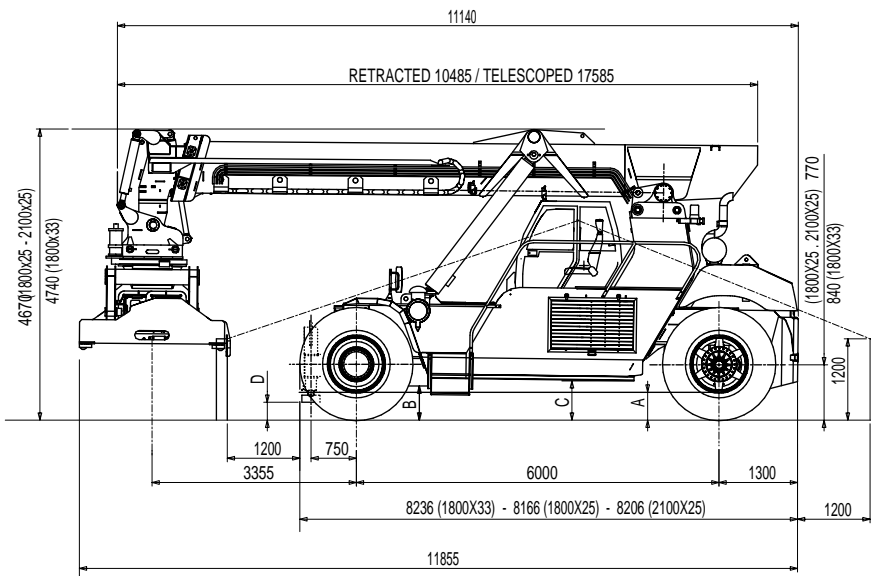

GARDE AU SOL - GROUND CLEARANCE		
	1800 x 25	1800 x 33
<b>A</b>	320	390
<b>B</b>	420	490
<b>C</b>	500	570
<b>D (RS)</b>	315	385

VOIES - TRACKS		
	AV / F	AR / R
1800 x 25	3033	2770
2100 x 25	3167	2870
1800 x 33	3033	2770

**TFC 45 L - LS - LX - LSX**

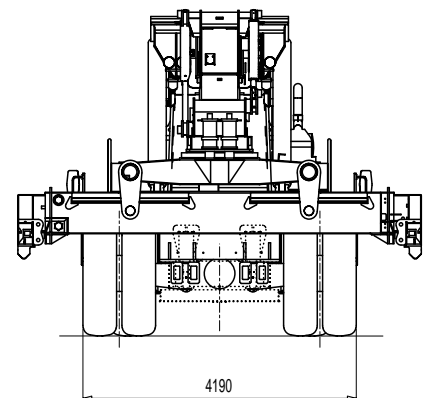
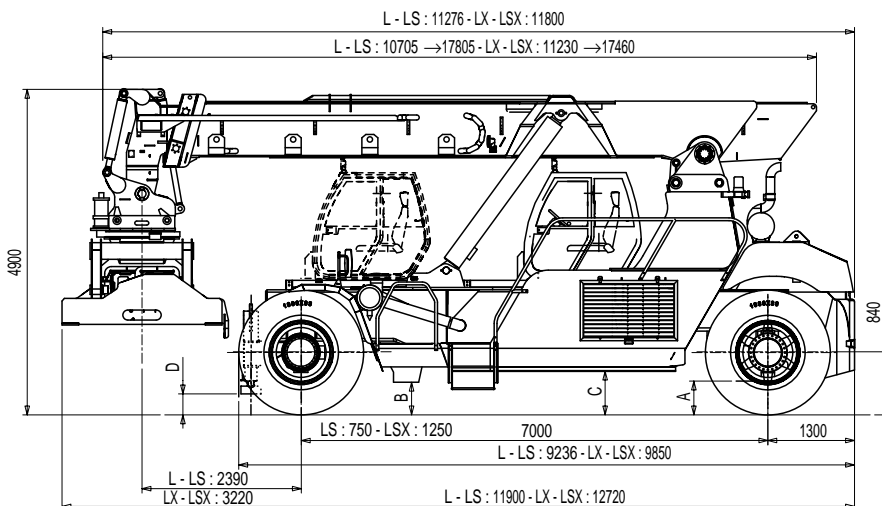

GARDE AU SOL - GROUND CLEARANCE	
	1800 x 33
<b>A</b>	390
<b>B</b>	490
<b>C</b>	570
<b>D (LS - LSX)</b>	385

VOIES - TRACKS		
	AV / F	AR / R
1800 x 33	3033	2770

Cabine large coulissante hydrauliquement en standard - Wide powered sliding cab in standard

**20' - END-ON CAPACITY**

Top pick Spreader

DIN 15019  
DIN 15018  
ISO 4305

CE

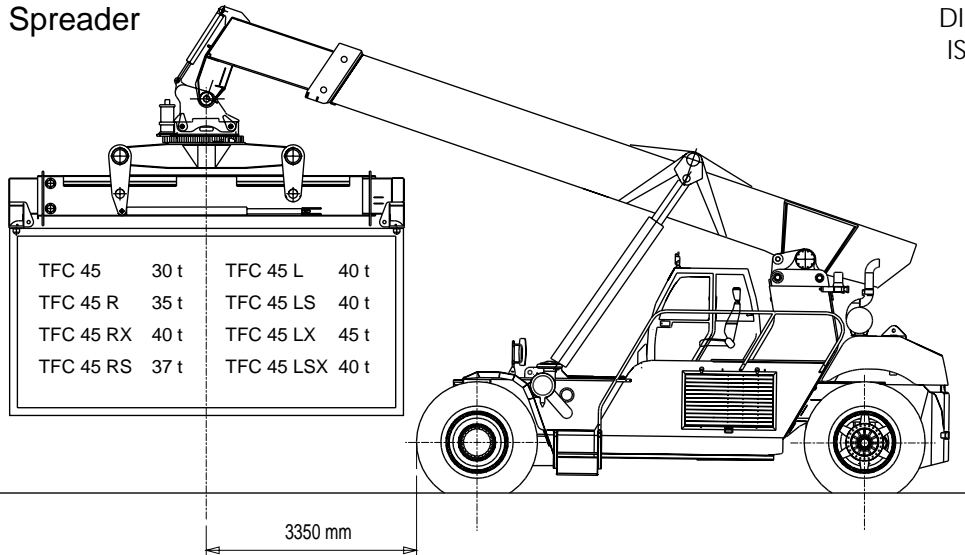

**40' - END-ON CAPACITY**

Top pick Spreader

DIN 15019  
DIN 15018  
ISO 4305

CE

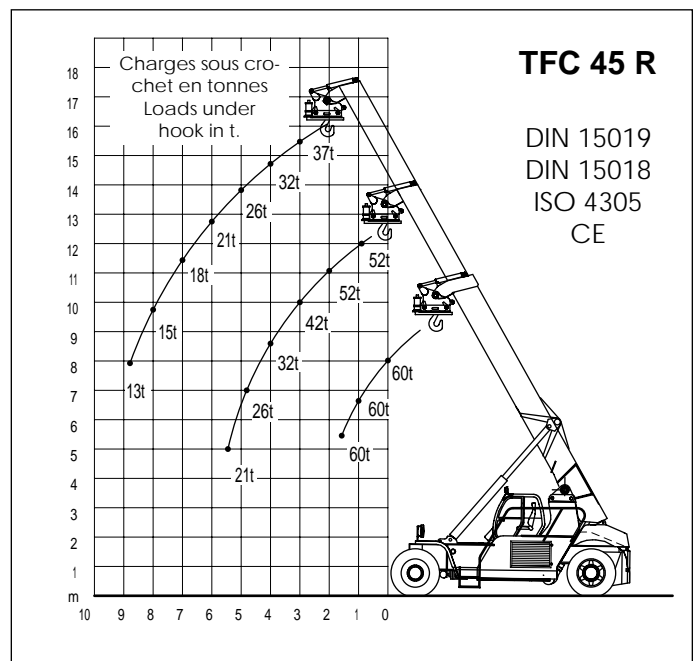
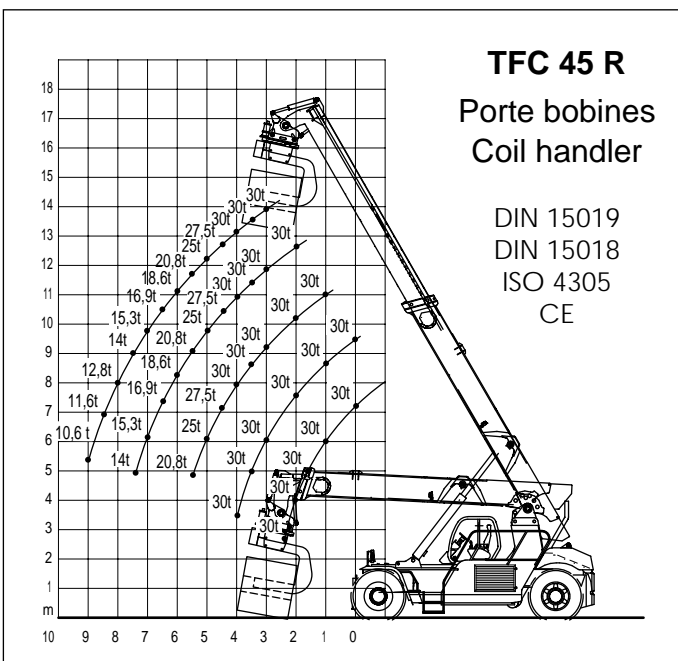
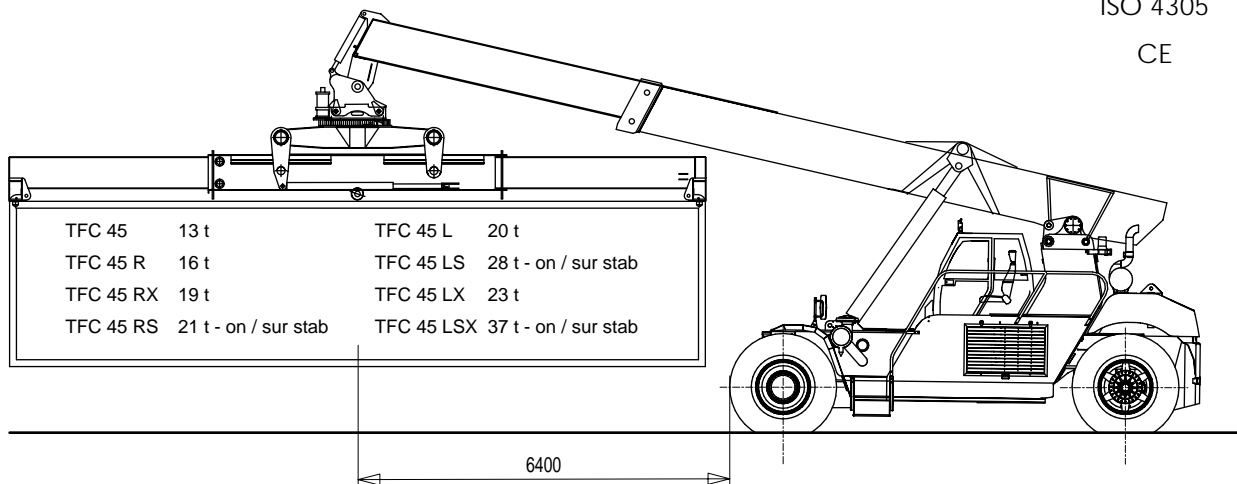

**PALONNIER STANDARD  
TOP PICK SPREADER**

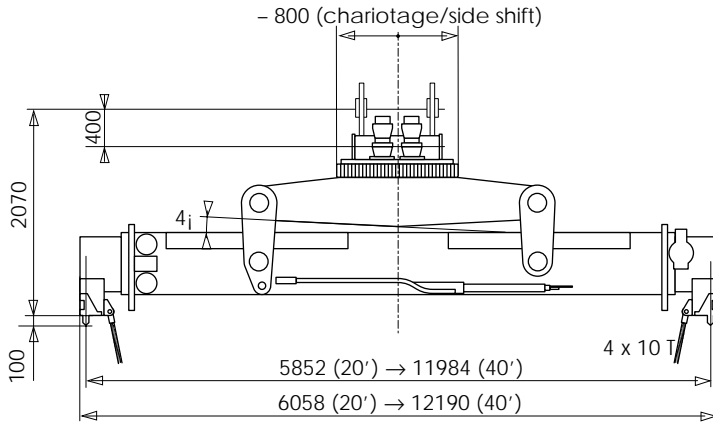

Poids	8,5 t	-
Tilt	± 4°	-
Orientation	+ 95°/-185°	31 s/60 s
Chariotage	± 800 mm	11 s
Télescopage 20' - 40'		12 s
Verrouillage		1 s

Weight	8,5 t	-
Tilting angle	± 4°	-
Slewing	+ 95°/-185°	31 s/60 s
Hydraulic side shift	± 800 mm	11 s
Télescoping 20' - 40'		12 s
Locking		1 s

**PALONNIER INTERMODAL AVEC TILT INTÉGRÉ  
INTERMODAL SPREADER WITH INTEGRATED TILTING**

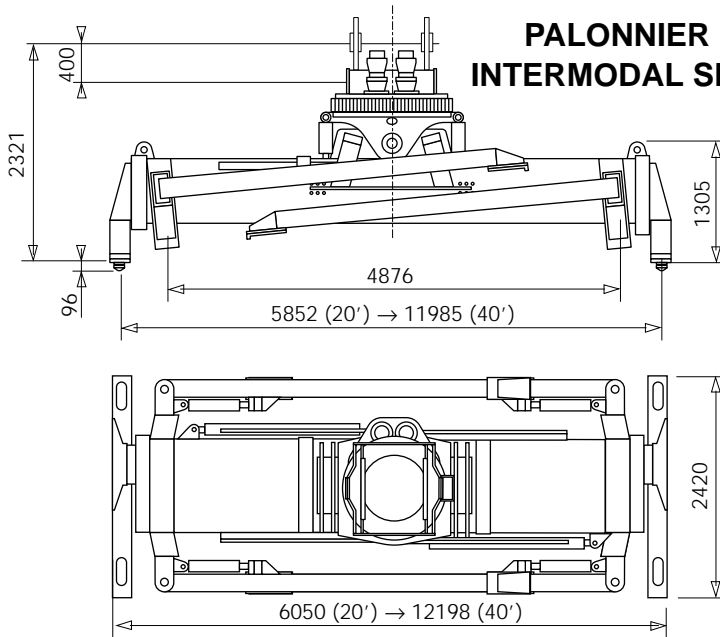

Poids	13,4 t	-
Tilt	± 6°	-
Orientation	- 185°/+ 105°	31 s/60 s
Chariotage	± 800 mm	11 s
Télescopage 20' - 40'	-	25/30 s
Dépliage (2)	-	11 s
Repliage (2)	-	8 s

Weight	13,4 t	-
Tilting angle	± 6°	-
Slewing	- 185°/+ 105°	31 s/60 s
Hydraulic side shift	± 800 mm	11 s
Telescoping 20' - 40'	-	25/30 s
Lowering (2)	-	11 s
Folding (2)	-	8 s

**INTERMODAL HANDLING APPLICATIONS**

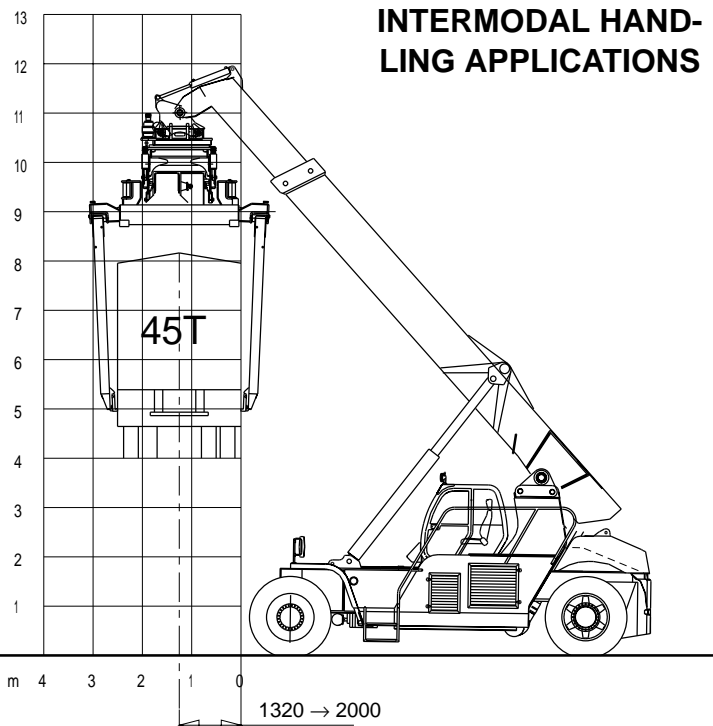







### OPTIONS

- Palonnier top/pick avec piggy back intégré
- Contrôleur d'état de charge
- Tilt  $\pm 5^\circ$  sur palonnier piloté depuis la cabine
- Crochet fixe capacité 60 t
- Pneus 18.00 x 33
- Cabine coulissante
- Graissage centralisé 53 points
- Siège passager
- Camera vision arrière
- Kit grand froid
- Couleur client

- Intermodal spreader
- Load moment indicator
- Powered Pile Slope  $\pm 5^\circ$  tilt, side to side
- Fixed hook 60 t
- Tires 1800 x 33
- Hydraulic sliding cab
- 53 points automatic greasing device
- Second seat
- Rear vision camera
- Low temperature kit
- Customer colour



The information contained in this brochure / product catalogue merely consists of general descriptions and a broad compilation of performance features which might not apply precisely as described under specific application conditions or which may change as a result of further product development.

The desired performance features only become binding once expressly agreed in the final contract.  
Subject to change without notice !

Les informations figurant dans la présente brochure / le présent catalogue de produit sont de simples descriptions ou des caractéristiques de performances générales qui ne correspondent pas toujours à la forme décrite dans le cas d'applications spécifiques concrètes ou qui peuvent varier en fonction des perfectionnements apportés aux produits.

Seules les caractéristiques de performances expressément convenues à la signature du contrat engageant notre société.  
Sous réserve de modifications !

### Terex Cranes France SAS - PPM

Z.I. de la Saule - B.P. 106

F-71304 Montceau-les-Mines Cedex

Tél. 33 (0)3 85 67 38 58 - Fax 33 (0)3 85 67 39 35

[www.terex-ppm.com](http://www.terex-ppm.com)

[sales@ppmterex.com](mailto:sales@ppmterex.com)

Agent