



MITSUBISHI VVVF TRANSISTOR INVERTER

FREQROL-Z200-UL

— INSTRUCTION MANUAL —



Thank you for your purchase of Mitsubishi Transistor inverter FREQROL-Z200. This inverter is a variable frequency power supply unit used to control a squirrel-cage induction motor.

IMPORTANT NOTE

This instruction manual describes handling, installation, operation and maintenance of the inverter.

Although it is easy to use the inverter, improper use and mis-operation might cause unforeseen trouble. Before operating the inverter, read this manual carefully.

Your inverter is built to a high standard of quality and reliability.

Correct application and regular inspection, should give you long, trouble free, operation.

- C O N T E N T S -

INVERTER

HANDLING GUIDANCE	1
§ 1. CONSTRUCTION	2
§ 2. UNPACKING AND CHECKING	5
§ 3. INSTALLATION	6
3.1 Handling during transfer and installation	6
3.2 Environment	6
3.3 Mounting position and clearances	6
3.4 Inverter housed in enclosure	7
§ 4. WIRING	8
4.1 Main circuit	8
4.2 Control circuit	12
4.3 Terminals for wiring	15
4.4 Field wiring reference table	17
§ 5. OPERATION	20
5.1 Operation modes	20
5.2 Pre-operation checks	20
5.3 Pre-operation settings and adjustments	21
5.4 Check points at test operation	24
§ 6. MAINTENANCE AND INSPECTION	27
6.1 Caution for maintenance and inspection	27
6.2 Inspection points	27

6.3 Method of measuring main circuit voltage, current and output power	31
6.4 Measuring instrument, selection and usage	34
6.5 Transistor modules and diode modules	36
6.6 Parts replacement	38
§ 7. TROUBLESHOOTING	40
7.1 Troubleshooting	40
7.2 Protective functions	44
§ 8. SPECIFICATIONS	51
8.1 Block diagram	51
8.2 Terminals	53
8.3 Standard specifications	58
8.4 External dimensions	64
8.5 Selection of peripheral devices	65
8.6 Drip shield kit	66
8.7 Overload protection	68

PARAMETER UNIT

§ 1. INSTALLATION	70
§ 2. OUTLINE OF FUNCTIONS	72
§ 3. FUNCTION KEY DESCRIPTIONS	73
§ 4. OPERATION	76
4.1 Operation modes	76
4.2 Operation with external signals	77
4.3 Operation with PU	78
4.4 Common setting errors see also Page 92	81
§ 5. SETTINGS OF CONTROL VARIABLES (PARAMETERS)	83
5.1 Control functions and setting method	83
5.2 Examples of operation	85
5.3 Caution (illegal settings)	87
§ 6. MONITOR	88
§ 7. DISPLAY	92
7.1 Alarm display	92
7.2 Indicator lamps	93
7.3 Characters appearing in readout	93
§ 8. LIST OF FUNCTIONS NUMBERS	94

§ 9. DETAILS OF EACH FUNCTION 97
§10. PARAMETER UNIT SPECIFICATIONS 112
§11. EXTERNAL DIMENSIONS AND CABLE DETAILS 113

HANDLING GUIDANCE

Improper use and operation might cause unforeseen trouble. Before using your inverter, please read this manual carefully to operate inverter for long time without trouble.

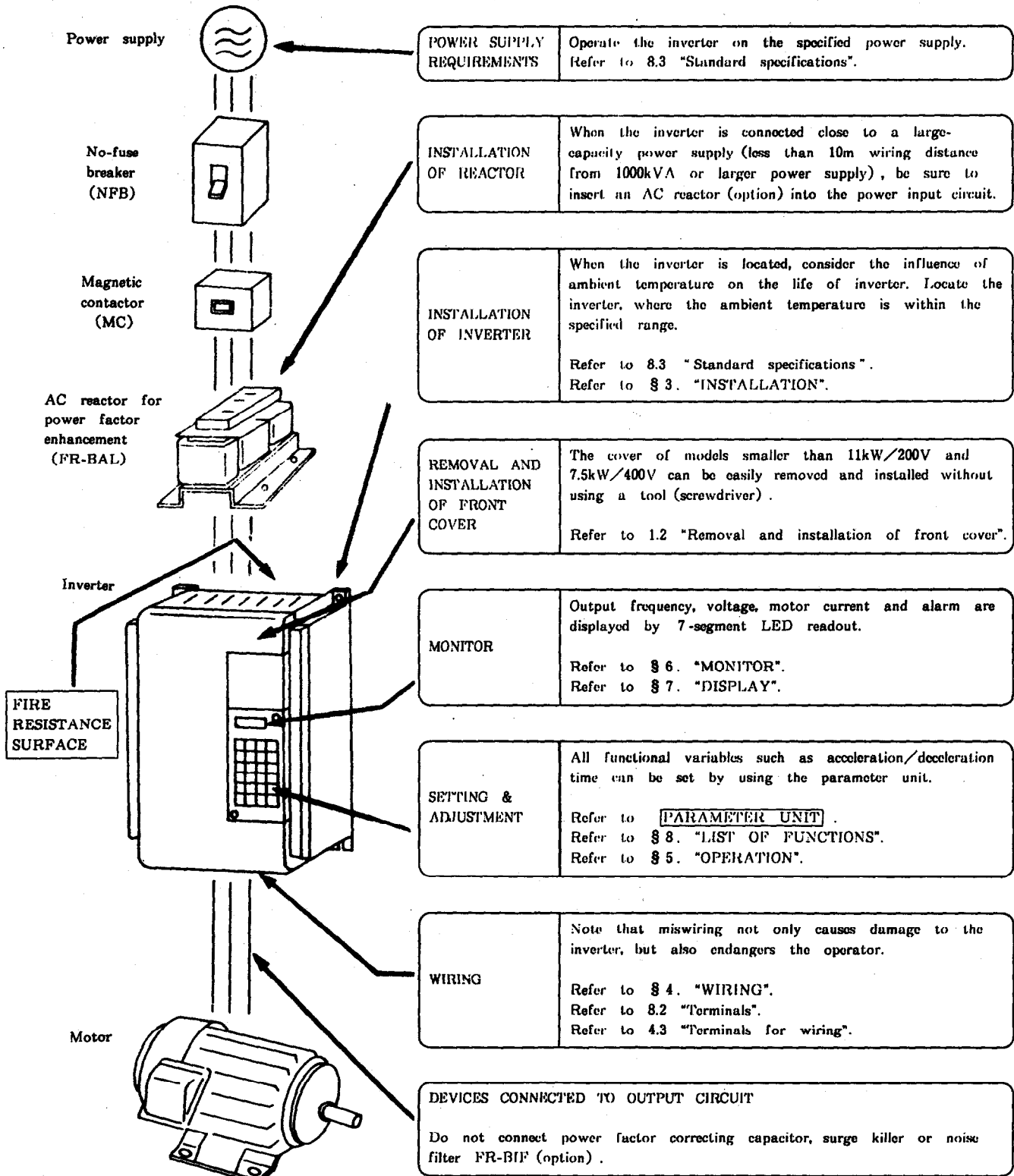

§ 1. CONSTRUCTION

1.1 External views and name of each part

●FR-Z220-0.4K(P)~11K(P), FR-Z240-2.2K(P)~7.5K(P)

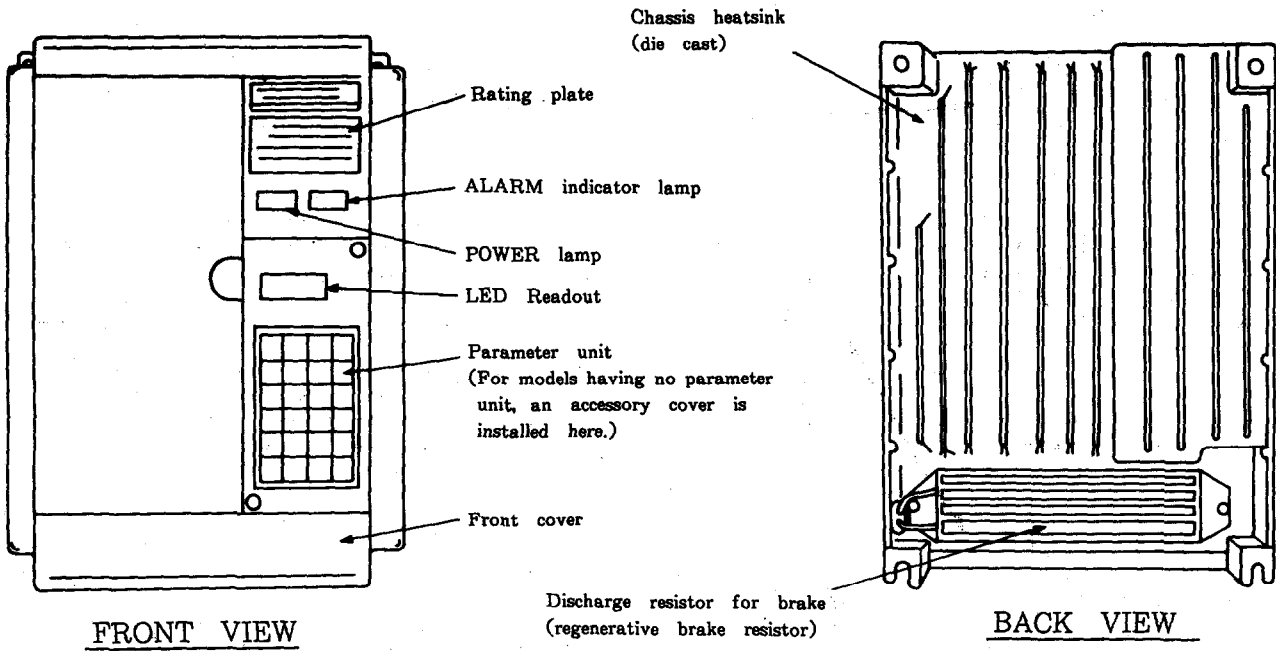

(For FR-Z220-0.4K)

●FR-Z220-15K~55K, FR-Z240-11K~55K

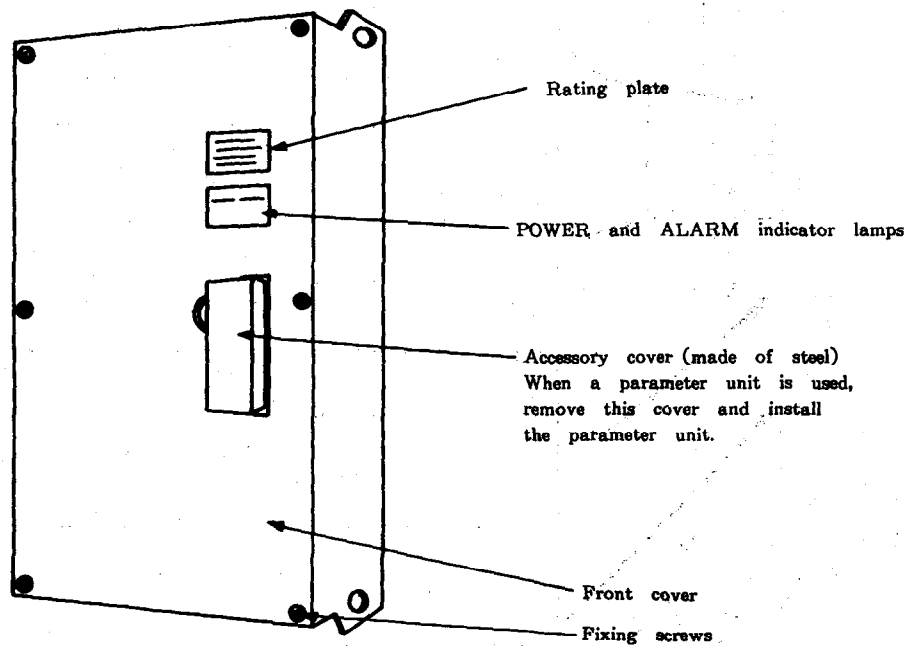

1.2 Removal and installation of front cover

(FR-Z220-0.4K~11K, FR-Z240-2.2K~7.5K)

How to remove the front cover (see Fig. 1) :

While pressing the white button at the top of the inverter, ease the cover forward and lift the plastic top cover from the bottom location sockets.

How to attach the front cover (see Fig. 2) :

Insert the lugs at the bottom of the front cover into the sockets at the chassis bottom and press the cover lightly against the chassis. Ensure white button engages securely.

Inverter having no parameter unit is equipped with an accessory cover. The accessory cover can be removed by pulling it to the front while holding the side wall lightly (Fig. 3) .



Fig. 1 Removal of front cover

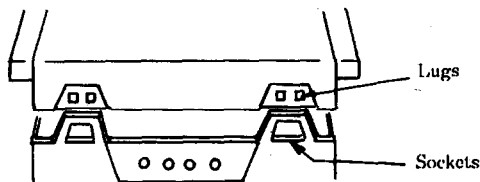

Fig. 2 Installation of front cover



Fig. 3 Removal of access cover

- CAUTION:
1. After the front cover is installed, make sure it is held in position securely.
 2. The rating plate is stuck on the front cover. Do not attach the cover to another inverter.
 3. When the parameter unit was removed for removal of the front cover, be sure to install it as instructed in 1.3.

1.3 Removal and installation of parameter unit

How to remove the parameter unit (Fig. 4) :

Remove two parameter unit mounting screws and ease the unit forward.

How to install the parameter unit:

Put the plug (connector) of the parameter unit into the connector of the inverter.

While holding the parameter unit in position, tighten two mounting screws.

(Do not over-tighten)

CAUTION: never install the parameter unit to the inverter with the front cover removed.

If the inverter must be operated with the front cover removed always use the extension cable. See page 113.

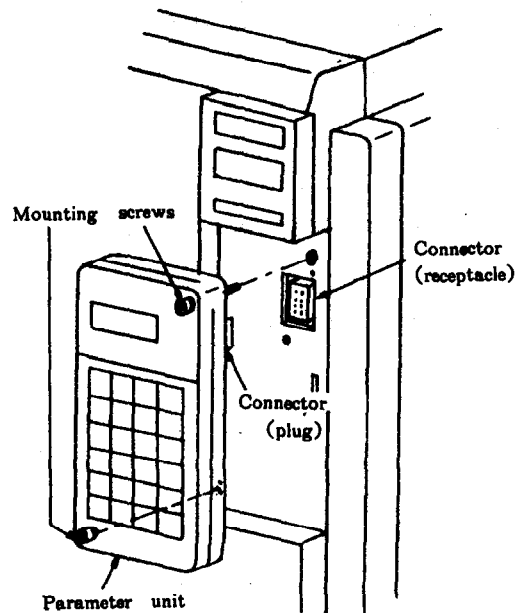

Fig. 4 Removal and installation of parameter unit

§ 2. UNPACKING AND CHECKING

After unpacking the inverter, check the following points.

- (1) Check the rating plate on the front cover of inverter to make sure the model and output ratings meet your order.
- (2) Check that the inverter has not been damaged during transportation. Report damage immediately.

a) To the carrier

b) To the inverter supplier

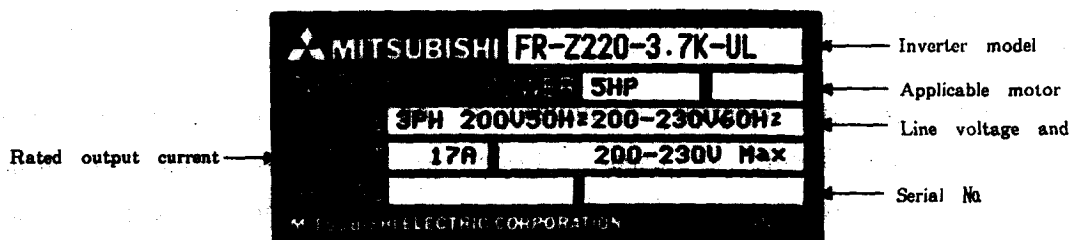
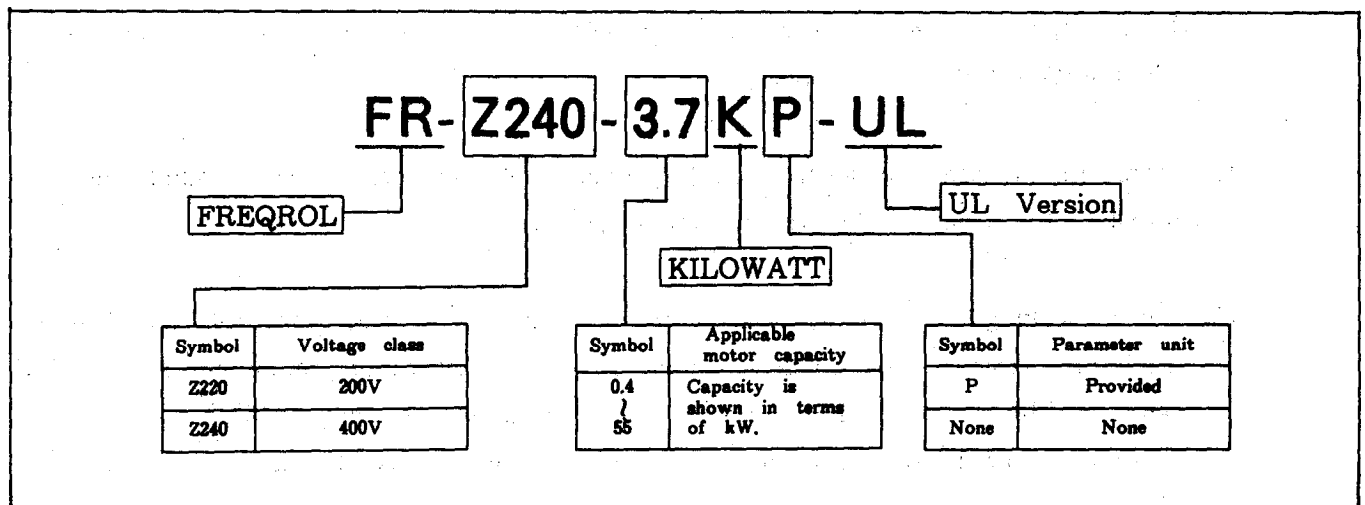

Fig. 5 Rating plate

INVERTER MODEL DESIGNATION



§ 3. INSTALLATION

3.1 Handling during unpacking and installation

Carefully handle the inverter when it is transferred and installed.

When the inverter is carried, do not hold it in such a manner that force is exerted on only the front panel.

3.2 Environment

- (1) Place the inverter in a clean and well-ventilated location.

Do not install the inverter in direct sunlight, high temperature, high humidity, dense dust, corrosive gases, or hazardous areas.

If the inverter must be used in an environment where dense dust or corrosive gas arises, house it in an enclosure which does not allow entrance of dust or gas.

Note: When the inverter is housed in an enclosure, a suitable cooling means should be used and/or the enclosure should be designed so that temperature around the inverter does not exceed the specified "ambient temperature" listed under paragraph 8.3.

- (2) Install the inverter in a vibration free location.

- (3) Cover the top and the bottom of the unit with drip shield kits (option) when an inverter is wall-mounted. (See page 66)

Do not install the drip shield kits when the unit is mounted within another cabinet.

3.3 Mounting position and clearances

- (1) Install the inverter securely and vertically with bolts so that the letters "FREQROL-Z200" face front.

- (2) Since the inverter generates heat, provide sufficient clearance around the inverter to assure effective radiation of heat.

- (3) When braking is repeated frequently, the surface temperature of the brake discharge resistor (for models under FR-Z220/Z240-7.5K), mounted at the rear of the inverter, may become high (maximum approx. 150°C).

Therefore, install the inverter on a non-flammable panel (such as metal plate).

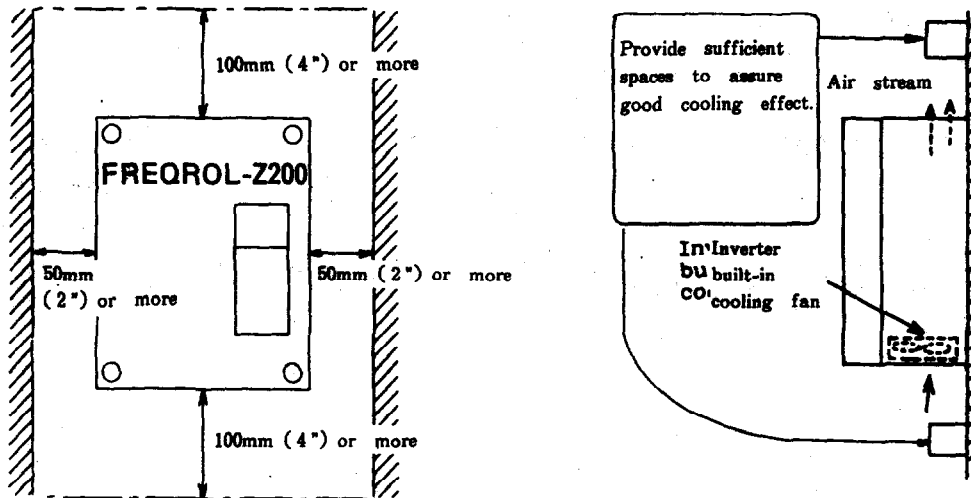

Fig. 6 Minimum clearance around inverter

CONSIDERATION FOR AMBIENT TEMPERATURE

The life time of the inverter depends on the ambient temperature. The ambient temperature should not exceed the permissive value.

Measure the ambient temperature at the positions shown in figure A.

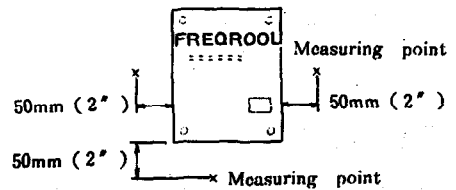
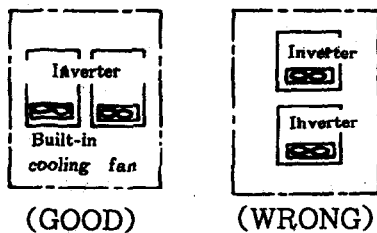

Fig. A

Permissive ambient temperature: $+50^{\circ}\text{C}$ ($+122^{\circ}\text{F}$)

3.4 Inverter housed in enclosure

When two or more inverters are housed in an enclosure equipped with a fan, locate each inverter and fan so that the maximum cooling efficiency can be achieved.



(GOOD)

(WRONG)

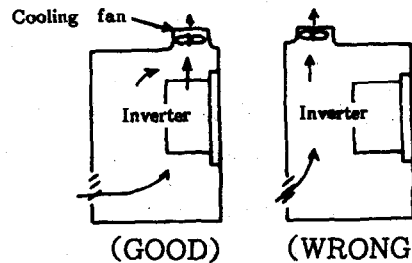

(GOOD)

(WRONG)

Two or more inverters housed in an enclosure

Location of ventilating fan

§ 4. WIRING

4.1 Main circuit

(1) Connection to power source and motor

For models FR-Z220-0.4K to 1.5K

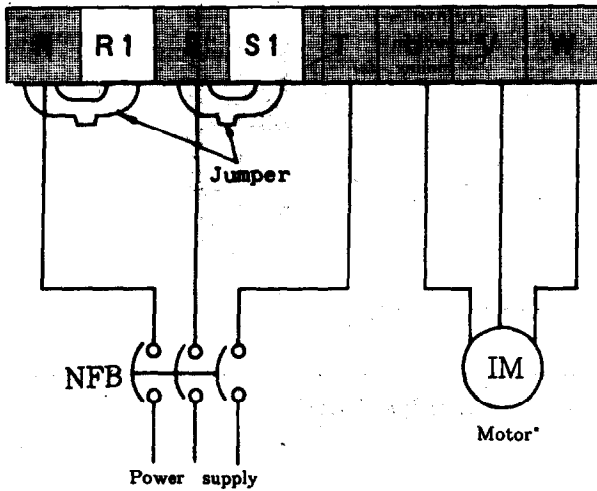

For models larger than
FR-Z220-2.2K and Z240-2.2K

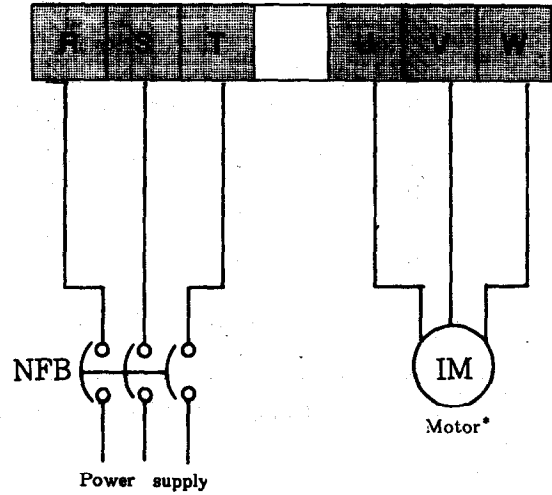

* When the inverter is connected as shown above, the motor runs counter-clockwise, as viewed from the load side, with "forward" (normal) command signal.

IMPORTANT

Notes: 1. Do not connect power supply to the output terminals (U, V, W) directly because such miswiring may cause not only damage to the inverter, but also danger to the operator.

The same danger may be caused by backflow of current if the inverter is connected as shown below. To prevent backflow, MC1 and MC2 should be interlocked with each other (electrically as well as mechanically).

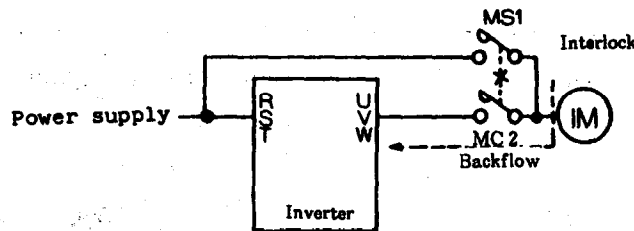

2. The inverter is not equipped with a means to protect persons from accidents due to leakage.

Pay attention so that cables do not touch the chassis, etc.

Be sure to earth the inverter with the earth terminal.

3. If magnetic contactor (MC) is not inserted on the inverter primary side and a power failure occurs for a short time (instantaneous power failure), the inverter will restart automatically at the same time as the power source is restored.

If it is likely that this automatic restart may cause damage to the machine or persinnel, connect (MC) so that restart is possible only after safety is verified.

For a better understanding, refer to the following diagrams and descriptions:

Para. 4.3 "Wiring diagram"

Para. 8.2 "Terminals for wiring"

Para. 8.1 "Block diagram"

CAUTION FOR WIRING OF PERIPHERAL DEVICES

When MC, NFB and other peripheral devices are being connected to the inverter, cover the inverter to prevent wire chips, screws and other foreign matter from entering into the inverter through slits and other openings of the inverter.

- (2) Connection of discharge resistor for increased braking (regenerative brake resistor unit option)

A built-in discharge resistor is been connected to terminals P and PR internally, as standard.

However when braking operation is particularly frequent and may exceed the thermal capacity of the built-in resistor, replace the built-in discharge resistor with optional discharge resistor unit.

Apply this option with care, due to increased heat losses which have to be dissipated.

Do not connect any resistor other than those specified by us, to terminals P and PR.

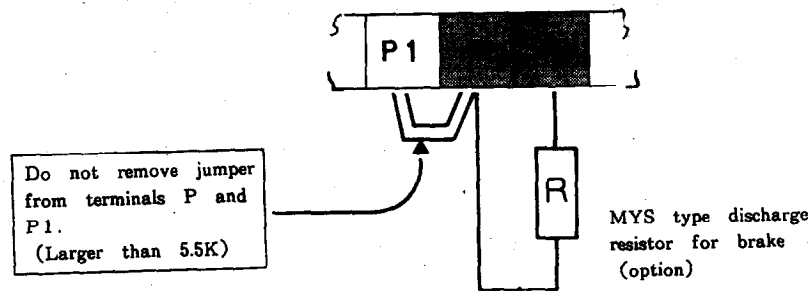

(3) Connection of BU type brake unit (option)

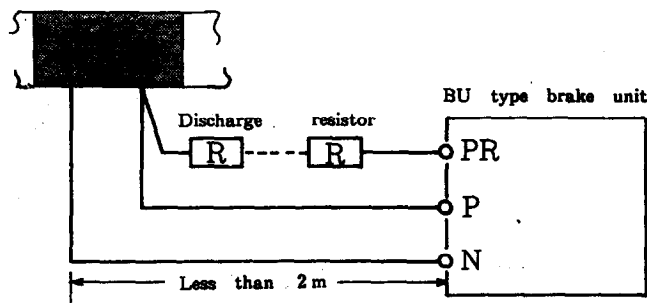

Note: Wires used to connect discharge resistor(s) and BU type brake unit to the inverter should be less than 2m (5m when twisted wires are used).

(4) Connection of control circuit power supply, independent of main circuit

If the magnetic contactor (MC) on the inverter input power supply side is opened when a protective device is activated, the inverter control circuit is also turned off and the alarm signal (output signal) is no longer held.

To hold alarm signal, the inverter control circuit should be fed with an independent power supply as shown below.

For models FR-Z220-0.4K to 1.5K

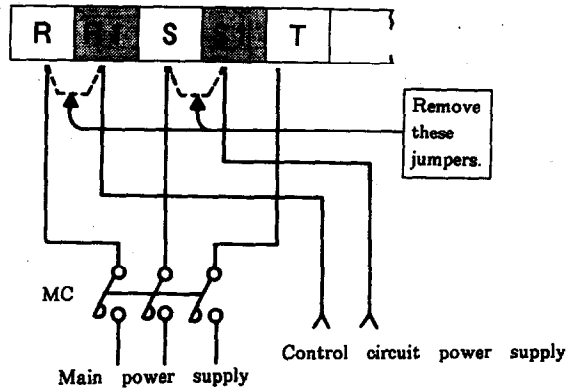

For models larger than FR-Z220-2.2K and Z240-2.2K

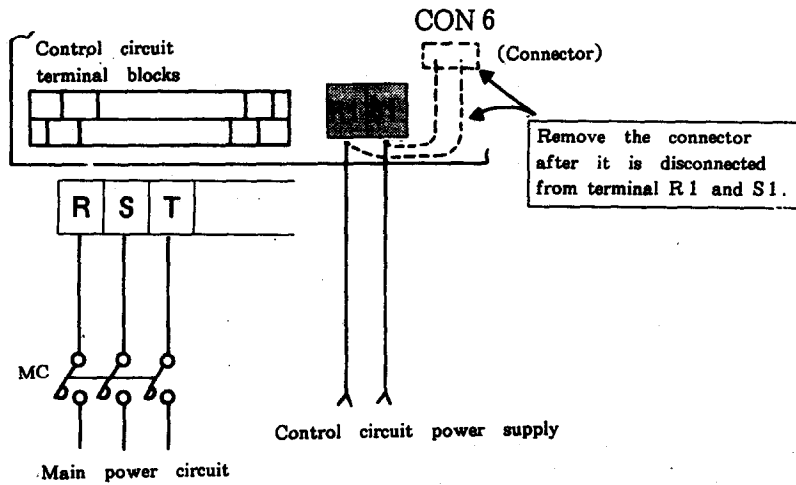

4.2 Control circuit

(1) Input signal circuits

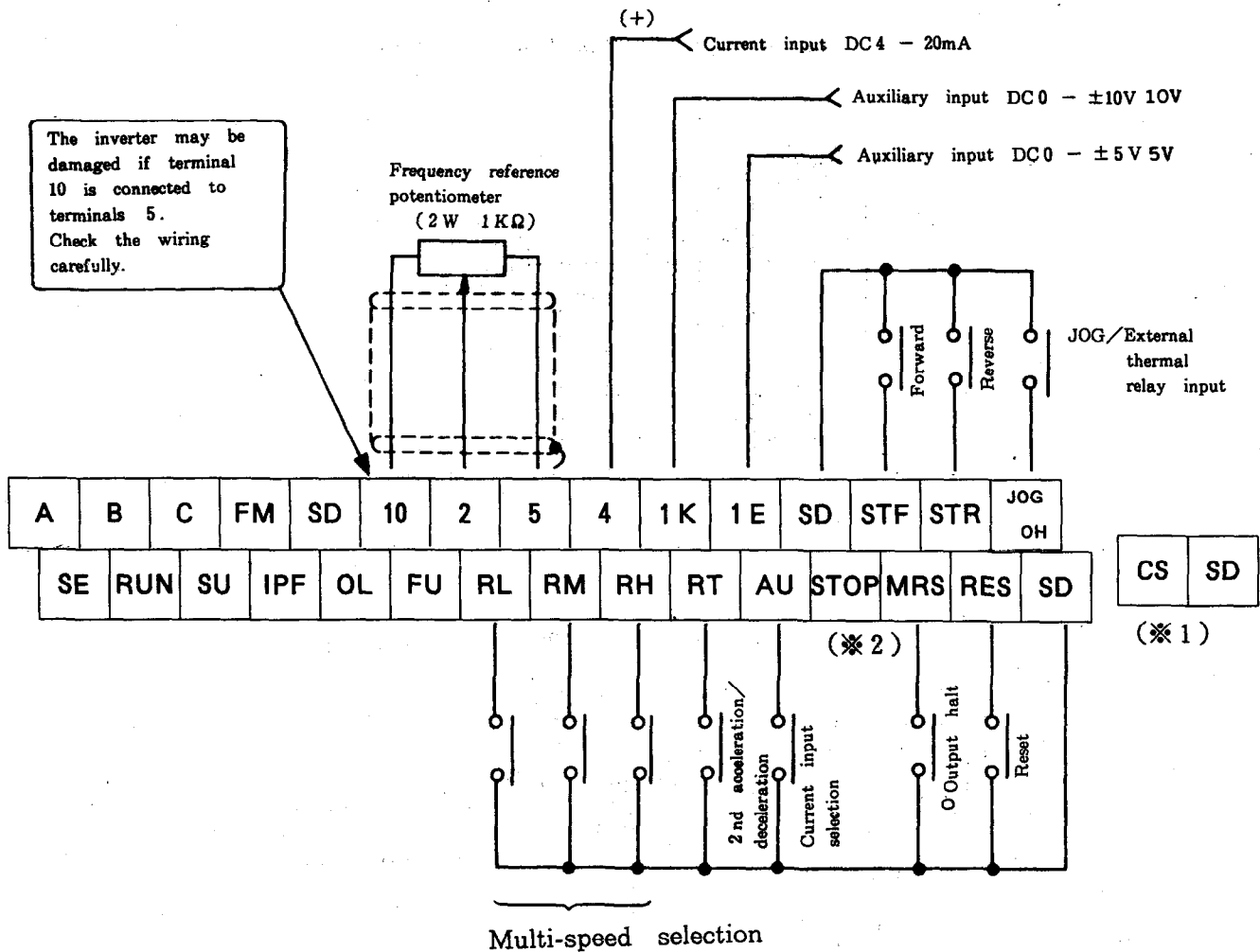

*1. CS terminal

This terminal is available in models larger than FR-Z220-15K and FR-Z240-11K. Use it for "restart after instantaneous power failure", or for "commercial power/inverter select".

- Restart after instantaneous power failure Short-circuit between terminals CS and SD.
- Commercial power/inverter select Use a circuit which closes the MC inserted on the inverter output side and at the same time short-circuit between terminals CS and SD.

For details, refer to the technical information.

*2. **STOP terminal**

This terminal can be used to hold "start" signal.

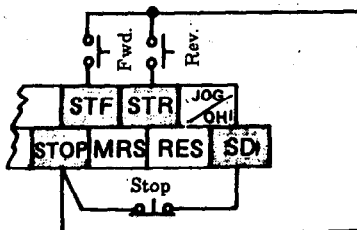

- Note:
1. Terminals SD and 5 are common terminals for input/output signals, and insulated from each other. Do not connect these terminals to ground.
 2. For signal wires connected to control circuit terminals of inverter, use shielded wires or twisted wires. These wires should be separated from cables for the main circuit and high-voltage circuits (including 200V relay sequence circuit).
 3. The speed reference signal is a faint current. To prevent mis-contact, use two parallel connections of faint signal contacts or twin contacts.

(2) Output signal circuits

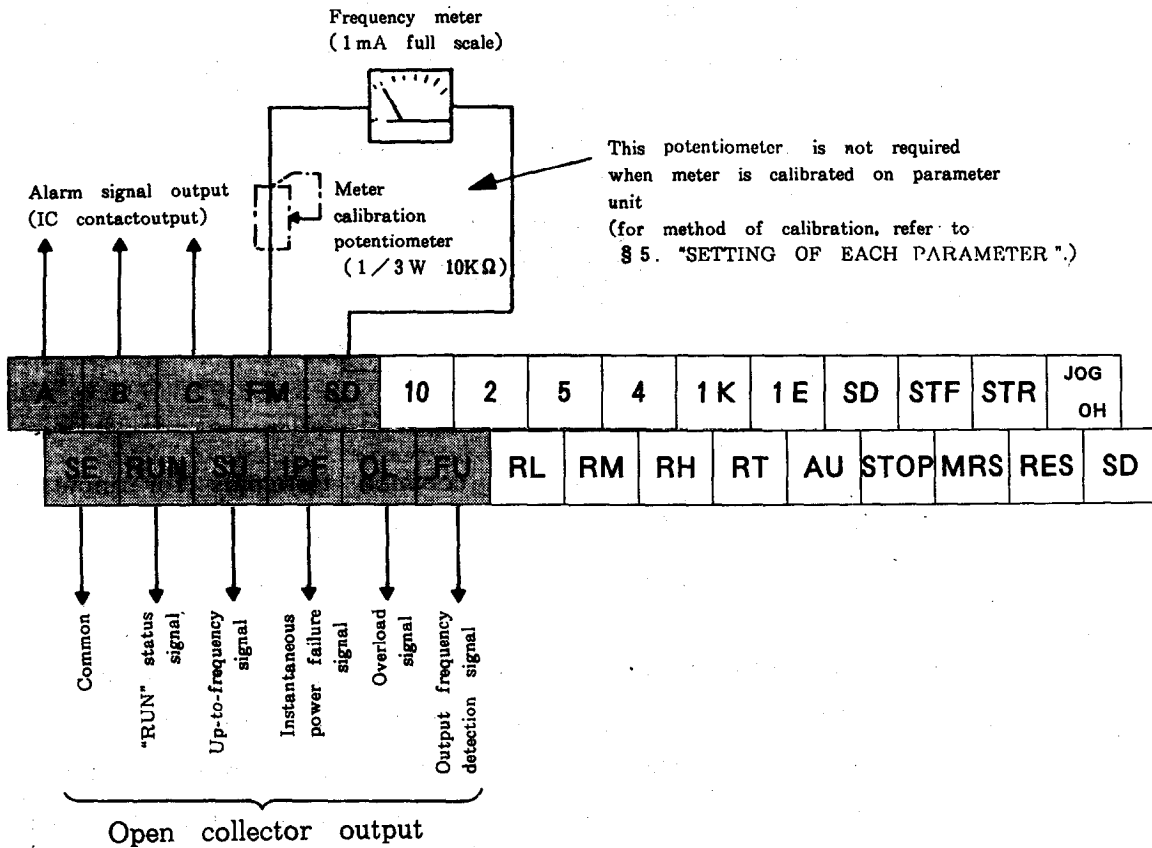

SIGNAL INPUT BY SEMICONDUCTOR SWITCH

A semiconductor can be used, instead of contacts (relay, switch, etc.), to generate an input signal.

● Applicable input signal terminals

All input signals except for analog input signals (2, 5, 4, 1K and 1E) (see the circuit diagram on page 12).

● Electric characters required for transistor

$$I_C \geq 100\text{mA}$$

$$V_{CE} \geq 50\text{V}$$

(Wiring example)

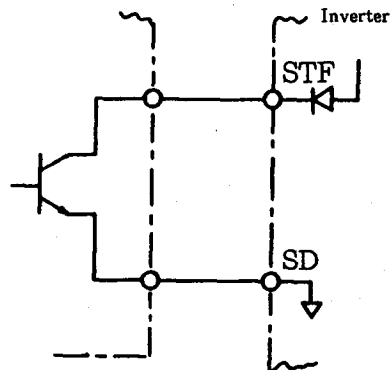

Note: For details, refer to the relevant technical information.

4.3 Terminals for wiring

◦ 200V class

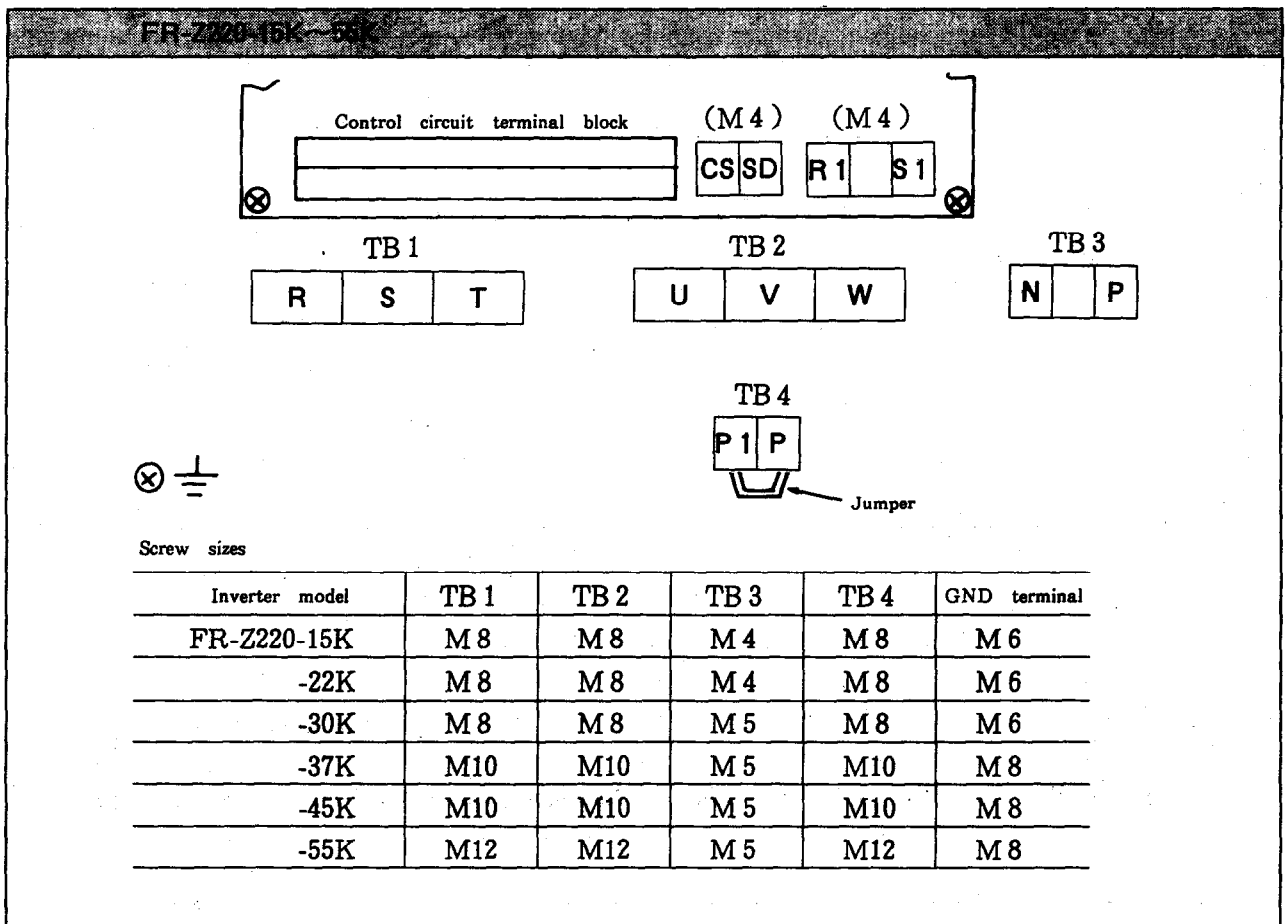
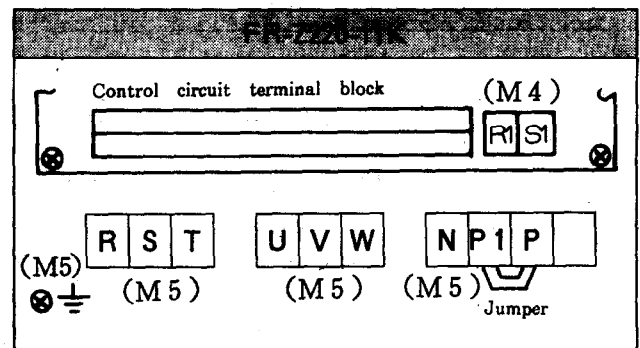
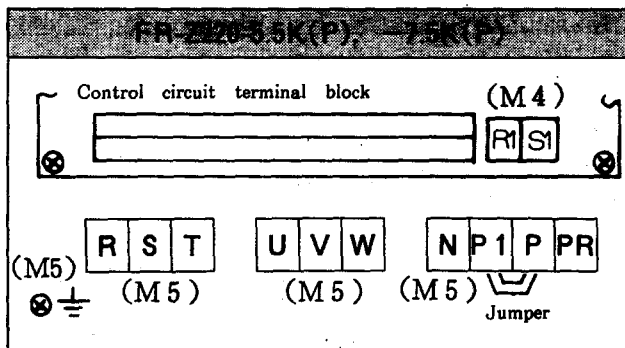
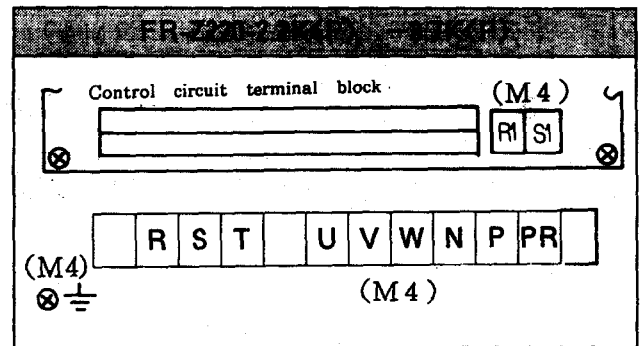
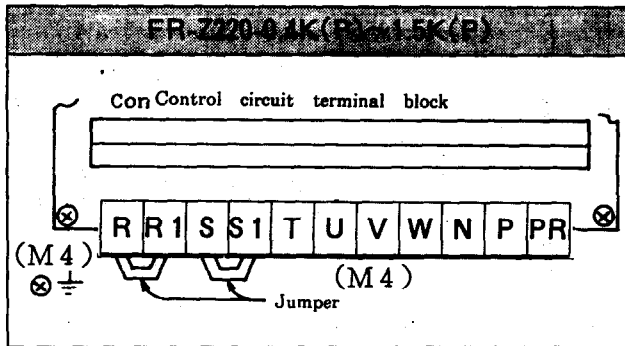

400V class

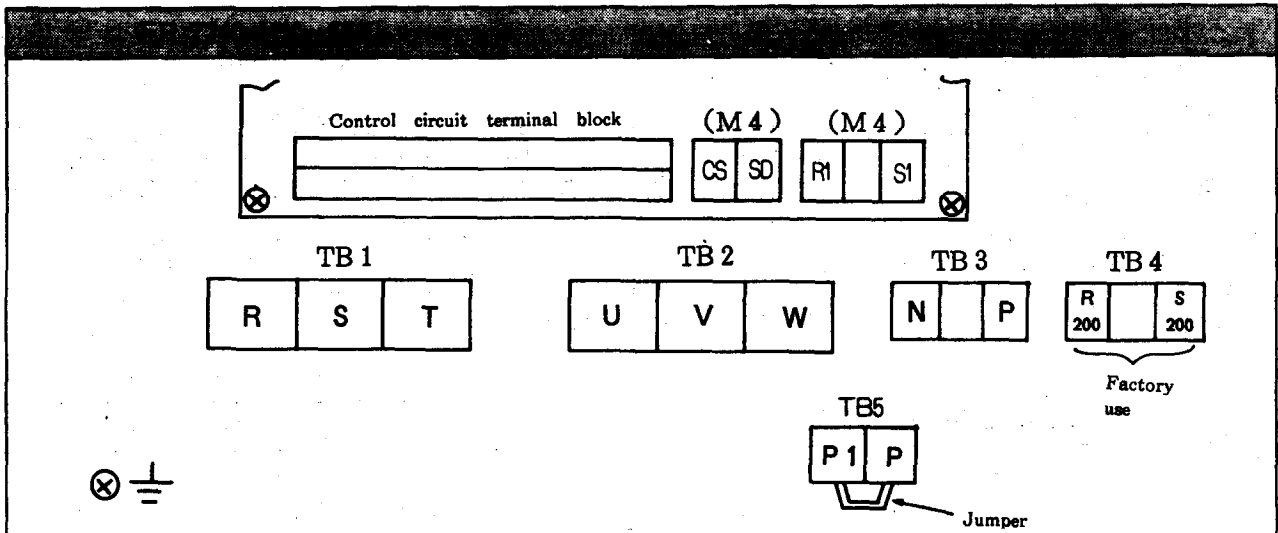
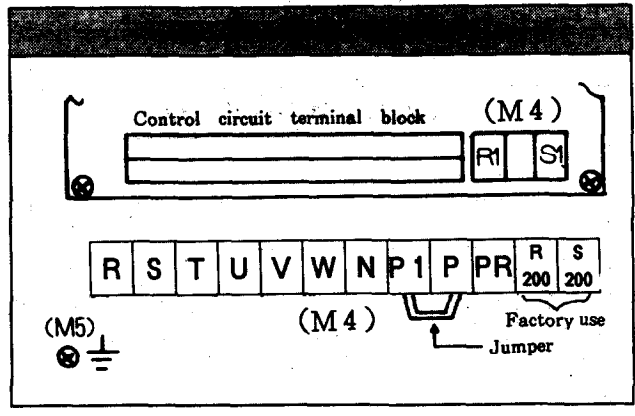
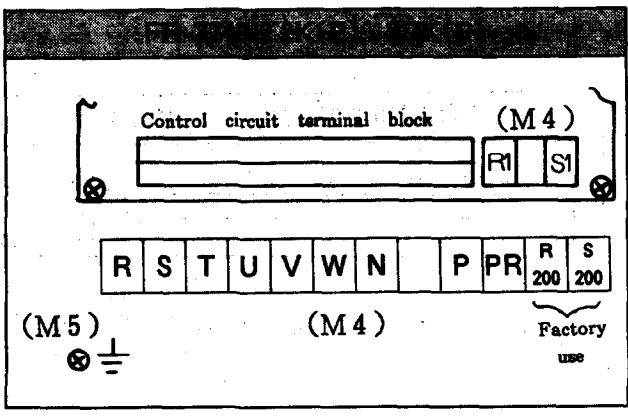

Screw sizes

Inverter model	TB 1	TB 2	TB 3	TB 4	TB 5	GND terminal
FR-Z240-11K, 15K	M 6	M 5	M 5	M3.5	M 6	M 6
-22K	M 6	M 5	M 5	M3.5	M 6	M 6
-30K	M 6	M 6	M 5	M3.5	M 6	M 6
-37K	M 8	M 6	M 5	M3.5	M 8	M 8
-45K, 55K	M 8	M 8	M 5	M3.5	M 8	M 8

CONTROL CIRCUIT TERMINAL BLOCK Common to all models
(except for R1, S1 and CS)

Type 2-stage molded terminal Screw size M3.5

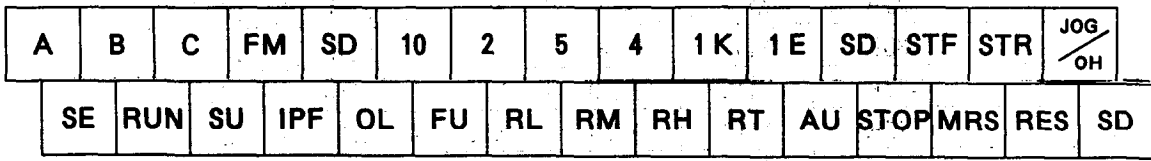

4.4 Field wiring reference table

For screw torque, crimping terminals and crimping tools, refer to the following table.

Note (* 1) Manufacturer: AMP INCORPORATED, HARRISBURG, PA 17105 •

PHONE: 717-564-0100 TWX: 510-657-4

(* 2) Use copper wire only

Voltage class	200V					
	Screw torque		Crimping terminals type and tool type (* 1)		Wire size and temp-rating (* 2)	
	Terminal block No	(Pound -Inch)	Crimping terminals	Crimping tools	Size	temp-rating
FR-Z220-0.4K(P)	TB1	10	32959	47387	AWG14	75°C
FR-Z220-0.75K(P)	TB1	10	32959	47387	AWG14	75°C
FR-Z220-1.5K(P)	TB1	10	32959	47387	AWG14	75°C
FR-Z220-2.2K(P)	TB1	10	32959	47387	AWG14	75°C
FR-Z220-3.7K(P)	TB1	13	32968	59239	AWG10	75°C
FR-Z220-5.5K(P)	TB1,2,3	23	321500 32543	59239	AWG10	75°C
FR-Z220-7.5K(P)	TB1,2,3	23	322128 322048 322002 322154	Hand tool 59974-1 Dies 48752-1	AWG8	75°C
FR-Z220-11K	TB1,2,3	23	322153 322005	Hand tool 59974-1 Dies 48753-1	AWG6	75°C
FR-Z220-15K	TB1,2,4	70	2-322010-3 322010	Hand tool 59974-1 Dies 48754-1	AWG4	75°C
	TB3	13	32968	59239	AWG10	75°C
FR-Z220-22K	TB1,2,4	70	322074 322013 326896	Hand tool 59974-1 Dies 48755-1	AWG2	75°C
	TB3	13	32968	59239	AWG10	75°C
FR-Z220-30K	TB1,2,4	70	322086 321674 328526	Foot Operated Power Unit 69325-3 Head 69066 Dies 48756-1	AWG1/0	75°C
	TB3	23	322153 322005	Hand tool 59974-1 Dies 48753-1	AWG6	75°C

Note: Terminal block location is shown in page 15.

Inverter model	Screw torque		Crimping terminals type and tool type (* 1)		Wire size and temp-rating (* 2)	
	Terminal block No	(Pound -Inch)	Crimping terminals	Crimping tools	Size	temp-rating
FR-Z220-37K	TB1,2,4	131	322094 322059 322160	Foot Operated Power Unit 69325-3 Head 69066 Dies 48758-1	AWG3/0	75°C
	TB3	23	322153 322010	Hand tool 59974-1 Dies 48753-1	AWG6	75°C
FR-Z220-45K	TB1,2,4	131	322097 322161 322601 324196	Foot Operated Power Unit 69325-3 Head 69066 Dies 48759-1	AWG4/0	75°C
	TB3	23	322153 322010	Hand tool 59974-1 Dies 48753-1	AWG6	75°C
FR-Z220-55K	TB1,2,4	219	322254	Foot Operated Power Unit 69325-3 Head 69060 Dies 48816	300MCM	75°C
	TB3	23	322153 322010	Hand tool 59974-1 Dies 48753-1	AWG6	75°C

Note: Terminal block location is shown in page 15.

Voltage class	400V					
Inverter model	Screw torque		Crimping terminals type and tool type (* 1)		Wire size and temp-rating (* 2)	
	Terminal block No	(Pound -Inch)	Crimping terminals	Crimping tools	Size	temp-rating
FR-Z240-2.2K(P)	TB1	13	32959	47387	AWG14	75°C
FR-Z240-3.7K(P)	TB1	13	32959	47387	AWG14	75°C
FR-Z240-5.5K(P) FR-Z240-7.5K(P)	TB1	13	32968	59239	AWG10	75°C

Note: Terminal block location is shown in page 16.

Inverter model	Screw torque		Crimping terminals type and tool type (*1)		Wire size and temp-rating (*2)	
	Terminal block No	(Pound -Inch)	Crimping terminals	Crimping tools	Size	temp-rating
FR-Z240-11K FR-Z240-15K	TB1,5	40	322049 321669 327268	Hand tool 59974-1 Dies 48752-1	AWG8	75°C
	TB2,3	23	322128 322048 322002 322154	Hand tool 59974-1 Dies 48752-1	AWG8	75°C
FR-Z240-22K	TB1,5	40	322051 321670 322155	Hand tool 59974-1 Dies 48753-1	AWG6	75°C
	TB2,3	23	322050 329161 322153 322005	Hand tool 59974-1 Dies 48753-1	AWG6	75°C
FR-Z240-30K	TB1,2,5	40	322051 321670 322155	Hand tool 59974-1 Dies 48753-1	AWG6	75°C
	TB3	23	322050 329161 322153 322005	Hand tool 59974-1 Dies 48753-1		
FR-Z240-37K	TB1,5	70	322074 326896 322013	Hand tool 59974-1 Dies 48755-1	AWG2	75°C
	TB2	40	322125 322054 321672 322157	Hand tool 59974-1 Dies 48755-1	AWG2	75°C
	TB3	23	322050 329161 322153 322005	Hand tool 59974-1 Dies 48753-1	AWG6	75°C
FR-Z240-45K	TB1,2,5	70	322074 326896 322013	Hand tool 59974-1 Dies 48755-1	AWG2	75°C
	TB3	23	322050 329161 322153 322005	Hand tool 59974-1 Dies 48753-1	AWG6	
FR-Z240-55K	TB1,2,5	70	322086 321674 328526	Foot Operated Power Unit 69325-3 Head 69066 Dies 48756-1	AWG1/0	75°C
	TB3	23	322050 329161 322153 322005	Hand tool 59974-1 Dies 48753-1	AWG6	75°C

Note: Terminal block location is shown in page 16.

§ 5. OPERATION

5.1 Operation modes

The inverter can be operated in any one of the following three modes:

Modes	Operation mode (FUNCTION 79)	Status after power is turned on (or reset)
0	Selection can be made between "operation with external signal" and "operation on parameter unit" by operating the parameter unit (this mode is selected when the inverter is shipped).	"Operation with external signal"
1	The inverter can be operated only on the parameter unit.*	"Operation on parameter unit"
2	The inverter can be operated only with external signal.*	"Operation with external signal"

Note *: To use these modes, function No 79 (operation mode) should be set on the parameter unit.

(For details, refer to chapter § 9.)

Mode 1 Operation with external signal Start switch, potentiometers, etc. connected to inverter signals are used as control signal sources.

Mode 2 Operation on parameter unit Only keys of parameter unit are used to control the inverter.

5.2 Pre-operation checks

IMPORTANT

After the inverter has been installed and wired, check the following points before operation:

- (1) Check that wiring is correct. Pay special attention to check that power supply cables are not connected to U, V and W terminals.

- (2) Check that there is no short-circuit due to wire offcut, etc.
- (3) Check that short-circuit and earth fault do not exist in the output circuit.
- (4) Check that all screws, terminals and other fasteners are tight.

CAUTION FOR INSULATION RESISTANCE TEST WITH MEGGER

- For insulation resistance test with megger, refer to § 6. 6.2, (3).
- Never apply the test voltage to the control circuit terminals and across the inverter terminals.

5.3 Pre-operation settings and adjustments

The inverter itself does not have control devices to set or adjust by operator, such as select switch and potentiometer. (As with previous models of FREQROL)

When settings (accelation/deceleration time, electronic thermal relay setting, etc.) must be changed, the parameter unit (FR-PUO1) is used (for the initial settings, refer to chapter § 8.) .

For methods of changing parameter setting, refer to the description "HANDLING AND OPERATION OF PARAMETER UNIT". (p. 69 - p. 113)

SETTING TABLE

	Description	Refer to
Acceleration/ deceleration time	<p>When the inverter is shipped, acceleration/ deceleration time is set to 5 sec. for models smaller than 7.5K, and to 15 sec. for models larger than 11K.</p> <p>The time setting can be changed on the parameter unit.</p> <p>Acceleration/deceleration time is the time in which the inverter output frequency becomes equal to the frequency at 5 V of frequency reference signal voltage.</p>	<p>P. 83 P. 99</p>
Maximam output frequency	<ul style="list-style-type: none"> ● For operation with external signals <p>When the inverter is shipped, the maximum inverter output frequency is set as follows:</p> <ul style="list-style-type: none"> ◦ Voltage signal --- 60Hz at DC 5 V (or 10V) ◦ Current signal 60Hz a t DC20mA <p>Maximam output frequency setting can be changed by changing “frequency at 5 V frequency reference input signal (or at 20mA frequency reference signal) ”.</p> <ul style="list-style-type: none"> ● For operation with parameter unit <p>The maximum output frequency can be increased up to the maximum frequency limit (set to 120Hz when the inverter is shipped) .</p>	<p>P. 83 P. 97</p>
Electronic thermal relay	<p>Setting should be based on current ‘value (at 50Hz) indicated on the nameplate of the motor.</p>	<p>P. 83 P. 97</p>

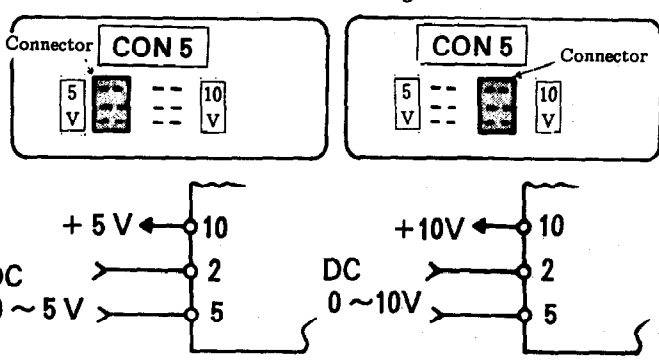
	Description	Refer to
<p>Frequency reference input signal (for operation with analog signal)</p>	<p>When an analog signal from an external signal source is used as a speed reference signal, the signal voltage range can be specified (up to DC5V or DC10V) by changing engagement of "input signal select" connector (CON5) on the P.C. board.</p> <p>When a potentiometer is connected to terminals 10, 2 and 5 directly, however, engagement of the connector is not required to be changed.</p> <p>● For operation with signal of DC0 to 5V ● For operation with signal of DC0 to 10V</p>  <p>Note: The inverter cannot be operated if the connector is not engaged.</p> <p>● Operation with current signal (DC4 - 20mA)</p> <p>DC current (DC4 - 20mA) is applicable when terminal AU is connected to terminal SD.</p> <p>See page 12.</p>	
<p>Frequency meter calibration</p>	<p>The frequency meter can be calibrated from the parameter unit (without use of potentiometer for calibration).</p>	<p>P. 83</p>

5.4 Check points at test operation

After making sure the inverter start signal is off (for operation with external signals), close the no-fuse breaker (NFB) and magnetic contactor (MC) on the inverter primary side.

Perform a test operation to check the sequence is in accordance with the following description:

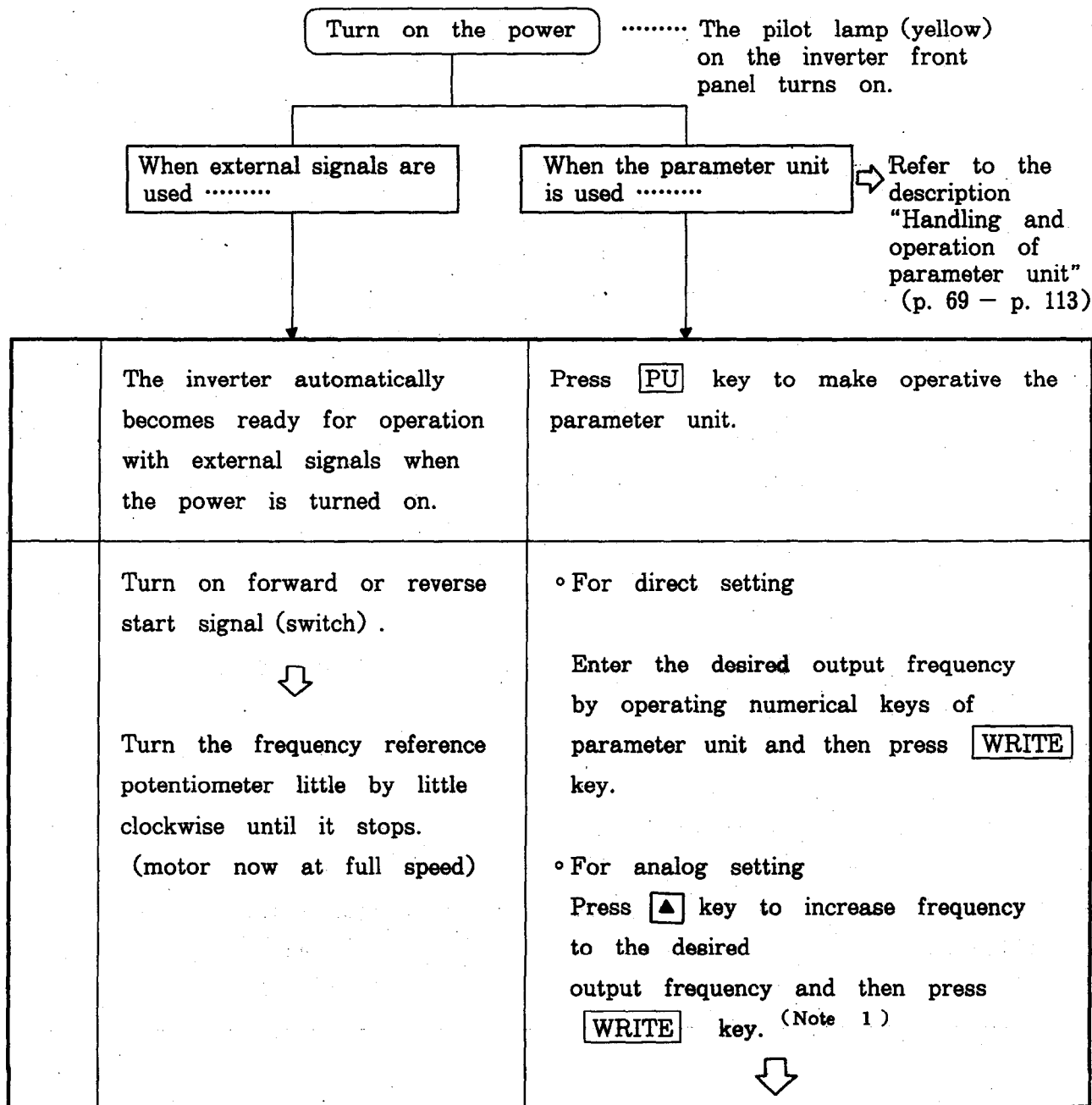

		Press FWD or REV key ("MONITOR" function becomes applicable automatically).
Deceleration ← Stop	Turn the frequency reference potentiometer little by little counter-clockwise to "zero" position. (motor now stopped)	Press STOP key. (Note 2)

Change of frequency is not displayed if the parameter unit is not set in "MONITOR" mode.

(Note 1) As the frequency displayed by the readout of parameter unit increases, the motor speed increases.

(Note 2) As the frequency displayed by the readout of parameter unit decreases, the motor speed decreases.

When the output frequency reaches the "DC brake operating frequency", the DC dynamic brake is activated and the motor is stopped immediately (refer to "CAUTION" described below).

Check points:

- (1) Check that the motor rotates in correct direction (for relationship between motor phase sequence and direction of rotation, refer to chapter § 4. WIRING.)
- (2) Check that the motor does not generate unusual hums or vibration.
- (3) Check that change of output frequency is displayed correctly.
- (4) Check if "ALARM" lamp lights during acceleration or deceleration (inverter trip). If it lights, perform the following check:
 - Check if load is too heavy.
 - Increase acceleration/deceleration time.
 - Reduce amount of boost.

CAUTION:

- (1) If the forward (STF) and reverse (STR) start signals turn on at the same time, the inverter will not start. If these signals turn on simultaneously during operation, the motor is decelerated (the inverter output frequency decreases) to a stop.

- (2) During deceleration, the DC dynamic brake is actuated for 0.5 seconds when the inverter output frequency decreases to less than the DC brake frequency (below the start frequency, when speed reference signal voltage (or current) is reduced gradually).
During this DC dynamic braking period, the motor may generate a high-pitched hum, but this is not a failure, nor a sign of trouble. This is normal during DC braking.

- (3) If "ALARM" lamp lights and the motor stops after coasting, check that the motor has stopped completely and then reset the inverter to shut off the power, using the reset terminal.

§ 6. MAINTENANCE AND INSPECTION

The inverter is a piece of static equipment consisting mainly of semiconductor elements.

To prevent trouble with the inverter, due to high temperature, humidity, dust, intense vibration, component deterioration, etc., it is very important to perform periodic inspection.

6.1 Caution for maintenance and inspection

- (1) Operator must check whether power supply is ON or OFF by himself to prevent misoperation by others.
- (2) After the power is switched off, the capacitor remains charged at high voltage for a while.

Before making an inspection, check that the CHARGE lamp on the P.C. board is off and voltage across the inverter main circuit terminals P and N is below DC30V, using a multimeter, etc.

6.2 Inspection points

This inverter is equipped with the power pilot lamp and error (alarm) display function.

It is advisable that you familiarize yourself with the error display definitions.

Also note the normal settings of the electronic thermal relay, acceleration/deceleration time, etc.

(1) Daily inspection

During daily operation, check the following:

- (a) The motor operates properly.
- (b) The environment is normal.
- (c) The cooling system is normal.
- (d) There is no unusual vibration and noise.
- (e) There is no overheat and discoloration in any component of the inverter.

During operation, check inverter input/output voltage with a multimeter.

(2) Periodic inspection

Check the followings periodically with the inverter stopped:

- (a) Check that the cooling system is in good condition.
Clean air filters, etc.
- (b) Screws, bolts, nuts and other fasteners may become loose with time, due to vibration, thermal expansion/retraction, etc.
Retighten loose screws or other fasteners.
- (c) Check if conductors and insulators are not corroded or damaged.
- (d) Measure insulation resistances.
- (e) Check the cooling fan, smoothing capacitor, contactors and relays for condition.

Table 2 shows the standard daily and periodic inspection schedule.

(3) Insulation resistance test with megger

- (a) Before checking insulation resistances of the external circuits with a megger, disconnect wires (cables) from all inverter terminals so that test voltage is not applied to the inverter circuits.
- (b) Conduct the insulation resistance test on the inverter main circuit only, as shown in Fig. 7.
Do not conduct the test on the control circuit of inverter.
- (c) To check the control circuits for continuity, use a multimeter (high resistance range).
Do not use a megger or buzzer to check.

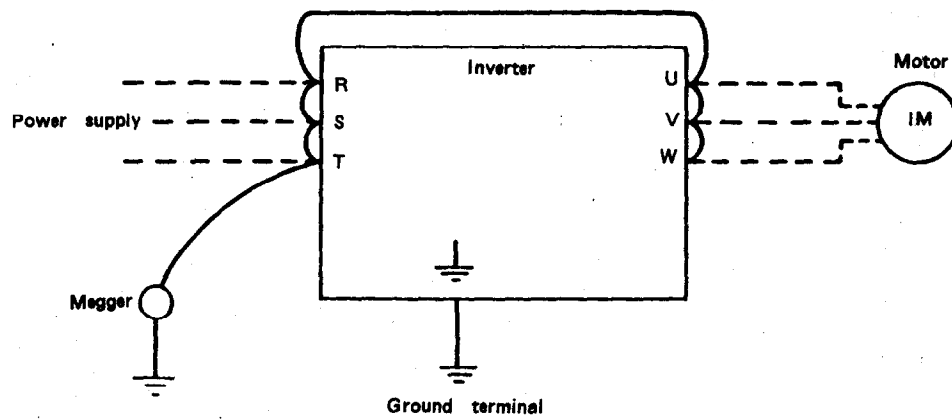

Fig. 7 Insulation resistance test with megger

Table 2 Daily and periodic inspection schedule

Check Point	Checking Item	Description	Inverter		Checking Method	Judgement	Measuring Instrument	
			Daily	Periodic				
				1 year				2 year
General	Environment	Check ambient temperature, humidity, dust, etc.	○			Refer to cautions on page 6.	Ambient temperature -10°C to $+50^{\circ}\text{C}$ ($+14^{\circ}\text{F}$ to $+122^{\circ}\text{F}$); No freezing. Ambient humidity 90%RH or less; No condensing.	Thermometer, hygrometer, recorder
	Whole equipment	Check that there is no unusual vibration and noise.	○			Visual and auditory checks.	Should be normal.	
	Supply voltage	Check that main circuit and control voltage are normal.	○			Measure voltage across inverter terminal block terminals R, S and T.	● 180 - 220V (380 - 440V) 50Hz ● 180 - 253V (380 - 506V) 60Hz	multimeter digital multimeter
Main circuit	General	(1) Check with megger (across main circuit and ground terminal). (2) Check that fastened parts are not loose. (3) Check that parts have no overheat trace. (4) Clean.		○	○	(1) Disconnect the inverter and measure resistance across batch of terminals R, S, T, U, V, W and ground terminal with megger. (2) Fasten. (3) Visual Check.	(1) 5 M OHM or larger. (2) (3) Should be normal.	500V megger
	Conductor, cable	(1) Check that conductor is not distorted. (2) Check that cable sheath is not broken.		○	○	(1) (2) Visual check.	(1) (2) Should be normal.	
	Terminal block	Check for damage.		○		Visual check.	Should be normal.	
	Transistor module Diode module	Check resistance across each terminals.			○	Disconnect the inverter and measure resistance across terminals R, S, T and P, N and across U, V, W and P, N with a multimeter by 1 OHM range.	Refer to Table 7-4.	Analog multimeter
	Smoothing capacity	(1) Check for leakage of electrolyte. (2) Check the safety valve. (3) Measure static capacity.	○	○		(1) (2) Visual check. (3) Measure with capacity measuring instruments.	(1) (2) Should be normal. (3) 85% or more of rated capacity.	Capacitor meter
	Relay, contactor	(1) Check for tremor. (2) Check for contact roughness.		○	○	(1) Auditory check. (2) Visual check.	(1) Should be normal. (2) Should be normal.	
	Resistor	(1) Check for resistor insulator crack. (2) Check for wire break.		○	○	(1) Visual check (Ceramic resistor, wound resistor, etc). (2) Disconnect lead on one side and measure with multimeter.	(1) Should be normal. (2) Error should be within $\pm 10\%$ of specified resistance.	Multimeter, Digital multimeter
Control circuit Protection circuit	Operation check	(1) Check output voltage balance across each phases without motor. (2) After sequence protective operation test, check that protective and display circuits should be normal.		○	○	(1) Measure voltage across inverter output terminals U, V and W. (2) Simultaneously short-circuit the inverter Alarm signal output.	(1) Voltage balance for 200V (400V) should be within 4V (8V). (2) Alarm circuit should be actuated.	Digital multimeter, rectifier type voltmeter
Cooling system	Cooling fan	(1) Check for unusual vibration and noise. (2) Check that connection is not loose. (3) Clean air filter.	○	○	○	(1) Switch power off and turn by hand. (2) Retighten.	(1) Should turn smoothly. (2) Should be normal.	
Display	Display	(1) Check that lamps have not blown. (2) Clean.	○	○		(1) Panel indicator lamps. (2) Clean with cloth.	(1) Clean that lamps light.	
	Meter	Check that reading is correct.	○			(1) Check panel meter reading.	(1) Should satisfy specified and control valves.	Voltmeter, ammeter, etc.
Motor	General	(1) Check for unusual vibration and noise. (2) Check for unusual smell.	○	○		(1) Auditory, tactile and visual checks. (2) Check for unusual smell due to overheat, damage, etc.	(1) (2) Should be normal.	
	Insulation resistance	(1) Check with megger (across batch terminals and ground terminal).			○	(1) Disconnect U, V and W, includes motor cables.	(1) Should be 5 M OHM or larger.	500V megger

6.3 Method of measuring main circuit voltage, current and output power

(1) Method of measuring voltage and current

Since the inverter power supply (input), output voltage and current include high-harmonic components, data (measurement results) depend on instrument and circuit used in measurement.

To measure voltage and current with an instrument for commercial frequency application, use the instrument in accordance with Table 3, and the circuit shown in Fig. 8.

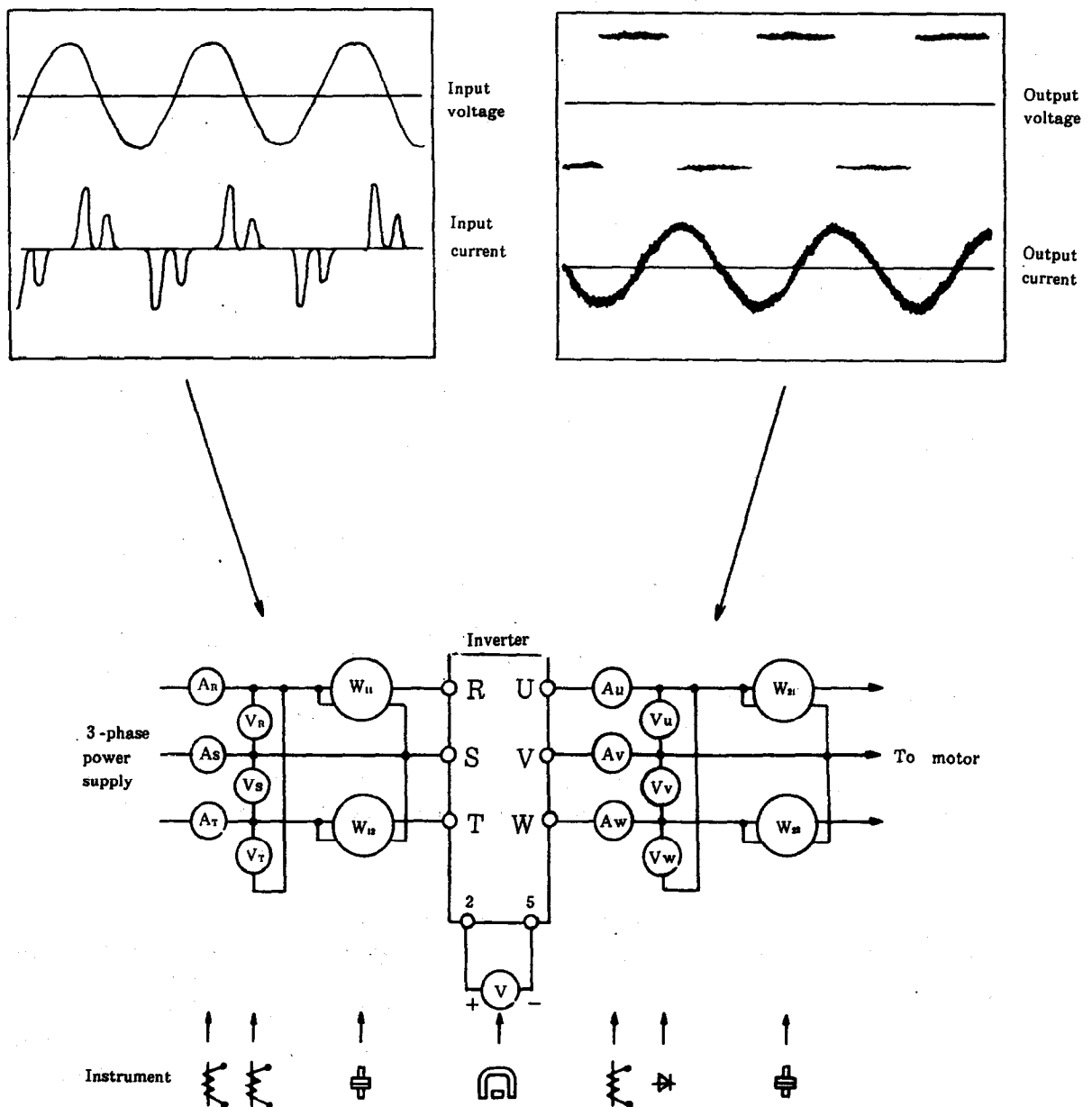









Fig. 8 Measuring points and instruments

Table 3 Measuring points and measuring instruments

	Measuring point	Instrument	Remarks (Criterion)
Line voltage V_1	Across R and S, S and T, and T and R	 Moving-iron type	Commercial voltage ◦ 180 - 220V (360 - 440V) 50Hz ◦ 180 - 253V (360 - 506V) 60Hz
Input current I_1	R, S and T line current	 Moving-iron type	
Input power P_1	On R, S and T, and across R and S, and S and T	 Electrodynamic type	$P_1 = W_{11} + W_{12}$
Input power factor Pf_1	To be calculated from the equation shown below after line voltage, input current and input power and measured. $Pf_1 = \frac{P_1}{\sqrt{3} V_1 \cdot I_1} \times 100\%$		
Output voltage V_2	Across U and V, V and W, and W and U	 Rectifier type (moving-iron type is not acceptable)	Difference between phases is $\pm 1\%$ or less of maximum output voltage.
Output current I_2	U, V and W line current	 Moving-iron type	Current should be equal to or less than inverter rated current. Difference between phases is 10% or less.
Output power P_2	On U, V and W, and across U and V, and V and W	 Electrodynamic type	$P_2 = W_{21} + W_{22}$
Output power factor	To be calculated from the equation shown below $Pf_2 = \frac{P_2}{\sqrt{3} V_2 \cdot I_2} \times 100\%$		
Converter output	Across P and N	 Moving-coil type (such as multimeter)	POWER lamp should light. $1.35 \times V_1$ Max. voltage during regenerative braking: 380V (730V)

	Measuring point	Instrument	Remarks (Criterion)
Frequency reference signal	Across 2 and 5	<input checked="" type="checkbox"/> Moving-coil type (such as multimeter) (Min. internal resistance: 50kohm)	DC 0 - 5V / 0 - 10V
	Across 1K and 5		DC 0 - ± 10V
	Across 1E and 5		DC 0 - ± 5 V
	Across 4 and 5		DC 4 - 20mA
Frequency indicator signal	Across FM and SD	<input checked="" type="checkbox"/> Moving-coil type (such as multimeter) (Min. internal resistance: 50kohm)	About DC 5 V at max. output frequency when frequency meter is connected
Start signal Mode select signal	Across STF, STR, RH, RM, RL, JOG/OH, RT or AU and SD	<input checked="" type="checkbox"/> Moving-coil type (such as multimeter) (Min. internal resistance: 50kohm)	DC 20 - 30V when opened, 1 V or less when closed
Reset signal	Across RES and SD		
Output halt signal	Across MRS and SD		
Base current shutoff signal Error alarm signal	Across A and C Across B and C	<input checked="" type="checkbox"/> Moving-coil type (such as multimeter)	Continuity check ° Normal or power supply OFF A - C: Open B - C: Closed ° Error condition A - C: Closed B - C: Open

"5" for common

"SD" for common

6.4 Measuring instrument selection and usage

To observe the condition of insulation, voltage, current, signal level, waveform, etc., select an adequate instrument and use it in accordance with the following description:

(1) Measurements on main circuit

The measurements include power supply and output voltages and current measurements, load (motor) continuity check, insulation check, voltage and current waveform observation.

The followings are particularly important to be checked carefully with the specified instrument(s):

① Multimeter

For continuity check with a multimeter, be careful of sneak path circuit. Do not make continuity check for the inverter circuit transistor module with the motor connected, and for the converter circuit diode module with the power connected.

Make continuity check only for components to be checked with the wiring to other components disconnected.

② Voltmeter and ammeter

The input power supply voltage is sine-wave of the commercial frequency. To measure the input voltage, any appropriate instrument may be used.

Since the input and output current waveforms include various high-harmonic components, use a moving-iron type ammeter, as it indicates values in r.m.s., to measure the input and output currents.

To measure the output voltage, use a rectifier type voltmeter because it reads nearly the basic wave component of the voltage waveform which is used as the reference value of torque generated by the motor.

Anyway, it is important to record the instruments used and measurement results, and to always use the same instruments at inspection.

③ Oscilloscope

To measure high voltage (400V or higher), insulate the power supply of oscilloscope and use a high-voltage probe or insulate the point to be measured with a potential transformer or current transformer. In the latter case, the potential transformer or current transformer should have a capacity large enough to prevent magnetic saturation.

(2) Measurements on control circuits

The measurements on control circuits include measurements of frequency reference signal, inverter control voltage and observation of waveforms.

For accurate measurement, note the followings:

① Voltage measurement and waveform observation

Since the currents of these signals are faint and the impedances of the circuits are high, use an instrument, input resistance of which is as high as possible (100kohm to 1 Megohm).

It is recommended to use a digital multimeter or oscilloscope in the measurements.

Since input resistance of multimeter set in a low range is significantly low, value read by multimeter may be lower than the true value.

② Common line connection

Connect the common terminal of instrument to an optimum point of circuit (i.e. the common point nearest to the point measured).

③ Instrument characteristics

For waveform observation, use an oscilloscope which has characteristics that meet the waveform to be observed.

The inverter base drive waveform can be observed, for example, with a 10MHz oscilloscope. To measure transient waveform at rise of signal (dv/dt or di/dt), however, an oscilloscope of 200MHz or larger frequency is required.

Table 4 Instruments and points to be measured

Instruments	Measuring point			Measuring item				Description
	Main circuit	Control circuit	insulation	Conductivity	Voltage	Current	Waveform	
500V megger	○		○					Measure across batch of main circuit terminals and ground. (This does not apply to control circuit.)
Multimeter	○	○		○	○			Judges whether semiconductor element is proper or not. Used to know conductivity or resistance value.
Voltmeter	○				○			Measure line and inverter output voltage. Use a rectifier type.
Ammeter	○					○		Measure line and output current. Use a moving-iron type.
Oscilloscope	○	○			○	○	○	Used to observe waveform and measure transient voltage and current.
Digital multimeter	○	○			○			Used to measure circuit voltage instead of multimeter.

6.5 Transistor modules and diode modules

To check transistor modules and diode modules, follow the procedure described below.

(1) Preparation

- Disconnect the power supply cables (R, S, T) and motor cables (U, V, W).
- Prepare a multimeter (set the multimeter to "1OHM" resistance measurement range).

(2) Checking method

Alternate polarity of multimeter with the multimeter probes connected to inverter terminals R, S, T, U, V, W, P and N and check for continuity as listed in Table 5.

Table 5 Checking the transistor modules and diode modules

		Multimeter polarity		Normal conditions			Multimeter polarity		Normal conditions
Diode module	D 1	R	P	Discontinuity	D 4	R	N	Continuity	
		P	R	Continuity		N	R	Discontinuity	
	D 2	S	P	Discontinuity	D 5	S	N	Continuity	
		P	S	Continuity		N	S	Discontinuity	
	D 3	T	P	Discontinuity	D 6	T	N	Continuity	
		P	T	Continuity		N	T	Discontinuity	
Transistor module	TR 1	U	P	Discontinuity	TR 4	U	N	Continuity	
		P	U	Continuity		N	U	Discontinuity	
	TR 3	V	P	Discontinuity	TR 6	V	N	Continuity	
		P	V	Continuity		N	V	Discontinuity	
	TR 5	W	P	Discontinuity	TR 2	W	N	Continuity	
		P	W	Continuity		N	W	Discontinuity	

Notes: 1. Before measurement, check that the smoothing capacitor have been discharged.

2. "Discontinuity" means that the multimeter reading is almost infinite. Due to electricity remaining in smoothing capacitor, the multimeter may indicate "continuity" momentarily.

"Continuity" means that the multimeter reading is about 1 - 100ohm, depending on number of total modules, number of modules connected in parallel, type of modules, etc.

If all measurement results are almost same, the modules are in good condition.

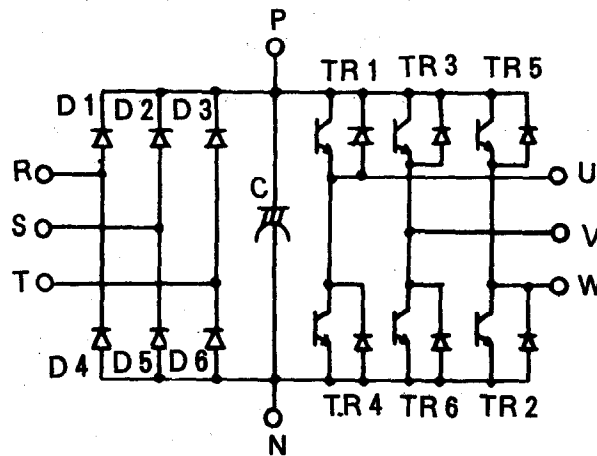

6.6 Parts replacement

The inverter consists of many electronic parts such as semiconductors.

The parts described below may deteriorate with time in electrical and physical characteristics.

As preventive maintenance, therefore, these parts require to be replaced periodically.

(1) Cooling fan

The service life of the bearings of the fan used to cool heatgenerating parts such as main circuit semiconductors is usually within a range from 10,000 to 35,000 hours. Hence, it is necessary to replace the cooling fan every 2 or 3 years.

If unusual noise and/or vibration is found during inspection, it is necessary to replace the cooling fan.

Smoothing capacitor

For smoothing (rectification of input power supply), large-capacity aluminum electric capacitors are used in the DC main circuit.

Its characteristics are adversely affected by ripple current, etc.

When the inverter is used in normal air-conditioned environment, for example, replace the capacitors about every 5 years.

When a capacitor is used for the period specified as life, it may deteriorate suddenly.

It is necessary to check all smoothing capacitors yearly (several months if life is about to expire).

Check the followings:

- ① Case : Side walls and bottom for deformation
- ② Sealing plate : For unusual warp and cracks
- ③ Pressure relief valve : For excessive valve expansion and operation

- ④ Appearance, crack in case, discoloration and leakage:

When capacitance of a capacitor is reduced below 85% of rated capacitance, replace that capacitor. To measure capacitance, use an instrument available commercially.

(3) Relays

To prevent miscontact, it is necessary to replace relays in accordance with the accumulated switching times.

For approximate interver parts replacement, refer to Table 6.

Other parts having a relatively short service life, such as lamps. Replace when deemed necessary as periodic inspection result will reveal.

Table 6 Inverter replacement parts

Part uame	Standard interval	Description
Cooling fan	2 to 3 years	Replace (determine after checking)
Smoothing capacitor	5 years	Replace (determine after checking)
Relays	-	Determine after checking

§ 7. TROUBLESHOOTING

If a fault occurs and the inverter does not work properly, determine the cause referring to the following troubleshooting list and apply the remedy.

If the cause cannot be determined in accordance with the list, the inverter or its part(s) is likely to be defective.

For remedy of serious trouble or any inquiry, contact the nearest service representative.

7.1 Troubleshooting

(1) Troubleshooting by indicator lamps of parameter unit

Indicator lamp.	Possible cause	Checkup	Remedy
OVT: Regenerative overvoltage shut off (deceleration time set improperly)	Overvoltage in DC output circuit (across terminals P and N)	Is deceleration too fast?	Increase deceleration time (it should meet load GD^2 (WK ²) ... inertia).
IPF: Instantaneous power failure	Instantaneous power failure	Determine the cause of instantaneous power failure.	
FIN: Heatsink overheat	Heatsinks are overheated.	Is cooling fan stopped (for models larger than 2.2K) ? Is ambient temperature too high?	Replace cooling fan. Reduce ambient temperature.
BE: Brake transistor fault	Brake transistor is defective.	Is brake operating duty proper?	Reduce load GD^2 (WK ²). Reduce brake operating duty.
OC1: Acceleration overcurrent	Overcurrent	Is acceleration too fast? Is outptt short-circuited?	Prolong acceleration time.

Indicator lamp	Possible cause	Checkup	Remedy
OC2: Steady speed overcurrent	Overcurrent	Is load changed suddenly? Is output short- circuited?	Eliminate sudden load change.
OC3: Deceleration overcurrent		Is deceleration too fast? Is output short- circuited?	Prolong deceleration time.
THM: Overload alarm	Motor thermal relay	Is motor overloaded?	Lighten load. Change motor/ inverter capacity.
THT: Overload alarm	Inverter thermal relay		
OLT: Stall prevention	Long-lasting action of stall preventive function	Is motor overloaded?	Lighten load. Change motor/ inverter capacity.
UVT: Under voltage	Low power supply voltage	Is a motor having a large capacity (connected in the same power line) started?	Check power supply line.
GF: Ground fault overcurrent	Ground fault in output line	Is output line or motor short-circuited to ground?	Check output line and motor, and remove short- circuiting.
OHT: External thermal relay trip	Thermal relay provided in external circuit is activated.	Does motor overheat?	Lighten load or duty.
OPT: Built-in option unit connection failure	Option unit is not connected to inverter properly.	Is connector engaged securely.	Securely engage connector.

If an indicator lamp lights, the motor stops after coasting.

To resume motor operation, remove the cause, reset the protective function and restart the inverter.

(2) Troubleshooting list

Trouble	Checkup	Remedy
Motor does not start ...	Are all wirings correct?	Correct wirings.
	Are voltages across power supply terminals R and S, S and T, and T and S normal (POWER and CHARGE lamps should light) ?	Supply voltages.
	Are there output voltages across terminals U and V, V and W, and W and U?	Supply voltages.
	Is motor locked (due to excessively large load) ?	Remove cause of locking of motor.
	Does ALARM lamp light?	See the previous page.
	Is parameter set up properly?	Check settings.
Motor starts and rotates in wrong direction ...	Are wirings of output circuit in correct phase sequence?	Correct output phase sequence.
	Are "FWD" and "REV" signal lines connected to correct terminals?	"FWD" signal: Terminals STF - SD closed "REV" signal: Terminals STR - SD closed
Motor runs, but its speed cannot be changed ...	Is frequency reference signal wiring correct?	Correct frequency reference signal wiring.
	Is load too heavy?	Lighten load.
Motor acceleration or deceleration is not smooth ...	Is time for acceleration or deceleration too short?	Prolong acceleration or deceleration time.

Trouble	Checkup	Remedy
Motor speed is out of control (motor speed is too high or low)	Are number of poles of motor correct? Does voltage meet specifications?	Check specifications and Rating Plate.
	Is gear reduction ratio correct?	
	Is maximum frequency set properly?	Check maximum frequency setting.
	Are voltages across motor terminals correct?	Check base frequency (V/F) .
Motor speed is unstable ...	Is load too large?	Lighten load.
	Is load change excessive?	Minimize load change. Increase inverter and motor capacities.

7.2 Protective functions

The inverter is provided with the following protective functions for protection from overcurrent or overvoltage.

If a protective function is activated, the transistor base current (output) is shut off and the motor stops after coasting. Its cause is displayed by the readout of parameter unit (when parameter unit is used).

For details, refer to the description "PARAMETER UNIT". (p. 92)

Function	Description	Remedy
Overcurrent stall prevention	<p>When 150% ^(Note*) or more of the inverter rated current flows into the motor during acceleration, this function stops increase of frequency (inverter output) until load current reduces to prevent the inverter from overcurrent tripping.</p> <p>When 150% or more of the inverter rated current flows during normal (constant-speed) operation, this function reduces frequency until load current reduces to prevent inverter from overcurrent tripping. After load current is reduced below 150%, this function allows increase of frequency up to the preset frequency.</p>	Prolong acceleration time or reduce load to prevent recurrence of action of this function.
Regenerative overvoltage stall prevention	If converter output voltage is increased excessively by regenerative energy during motor deceleration, this function stops decrease of frequency to prevent inverter from overvoltage tripping.	Prolong deceleration time.

Function	Description	Remarks
	As soon as regenerative energy has reduced, this function decreases frequency again to allow deceleration to continue.	
Overcurrent shutoff (OC1) (OC2) (OC3)	When 200% or more of the inverter rated output current flows, this protective function is activated to stop the inverter.	The most possible causes of overcurrent shutoff include inverter output short-circuit, ground fault, excessive load inertia (GD^2), extremely short setting of acceleration/ deceleration time, start during motor coasting, start of special motor or motor of capacity larger than inverter rating. Restart after examining and removing the cause.
Regenerative overvoltage shutoff (OVT)	When converter output voltage becomes excessive, due to regenerative energy from the motor, this protective function is activated to stop and hold transistor base current off.	This function is activated mainly due to short deceleration time or negative load.

Function	Description	Remarks
OVT (continued)		Prolong deceleration time (it should be noted that overheat of incorporated brake resistor may cause activation of this function).
Instantaneous power failure protection (IPF)	<p>To prevent failure when instantaneous power failure lasting for 15 msec or longer (also when inverter input power supply is shut off for 15 msec or longer) occurs, the instantaneous power failure protective function is activated and stops (and hold stopped) inverter output.</p> <p>In this case, alarm output contact is open (across B and C).</p> <p>(If power failure is shorter than 15 msec, operation continues normally.)</p>	<p>If power is switched on after inverter output shutoff, the resultant restart during motor coasting may trip the inverter.</p> <p>To prevent tripping of the inverter, use an automatic restart prevention circuit.</p>
Under-voltage protection (UVT)	<p>If the inverter input power voltage is below the specified minimum voltage, the inverter control circuit cannot function normally and the specified motor torque cannot be obtained or overheating may occur.</p> <p>When the input power voltage goes down below about 150V (about 300V in case of 400V class), undervoltage protective function</p>	<p>Under voltage may occur if capacity of power transformer is insufficient, or a motor having a large capacity connected to the same power line is started.</p> <p>Check the power line.</p>

Function	Description	Remarks
	is activated and stops (and holds stopped) inverter output.	
Brake transistor fault detection (BE)	If trouble occurs with brake transistor, this function detects it and shuts off inverter output.	Examine thermal capacity of brake resistor and regenerative braking duty (%ED) and use inverter having a larger capacity, if necessary.
Overload shutoff (Electronic thermal relay) (THT) (THM)	<p>Electronic thermal relay in the inverter detects overload of motor during operation under rated conditions, or motor overheating at low speed, and activates this protective function which stops (holds stopped) inverter output.</p> <p><u>CAUTION</u></p> <p>External overload protection must be provided to protect the motor in accordance with UL508 Par.144.3.</p>	Examine the cause of overload, and lighten load, change operation pattern, or use inverter having a larger capacity if necessary.
Heatsink overheat protection (FIN)	<p>Models larger than 2.2K are equipped with cooling fan(s).</p> <p>If the fan fails and the semiconductor heatsinks overheat, temperature sensor is activated to shut off (hold shut off) inverter output.</p>	Examine cooling fan operation and ambient temperature.

Function	Description	Remarks
Brake resistor overheat protection	<p>If regenerative brake energy from motor exceeds the specified value, the brake operation is stopped to protect the brake resistor from overheating.</p> <p>When the brake resistor is cooled, the brake operation restarts automatically.</p>	Prolong deceleration time or change operation sequence to reduce braking duty.
Ground fault current protection (GF)	If ground fault occurs on the inverter output side (load side) and ground fault current flows, the inverter output is shut off.	<p>Check if ground fault occurs on the load side (motor power circuit).</p> <p>After removal of the cause, restart operation.</p>
External thermal relay trip (OHT)	<p>If externally installed thermal relay for protection of motor from overheat (or motor built-in thermal relay) is activated (relay contact is opened), the inverter output is shut off and held shut off.</p> <p>This function is applicable when "external thermal signal input" function is selected. (FUNCTION 46)</p>	Examine load and motor duty to determine the cause of overheat.
Built-in option unit connection failure (OPT)	When an inverter built-in option unit is used and not connected properly (misengagement of connector, for example), the inverter is shut off.	Check connection (connector engagement) of option unit.

Note *: The stall prevention threshold level is set to "150%" of inverter rated current when the inverter is shipped. This setting can be changed by user (the overcurrent stall prevention is activated at the threshold level set by user). Use this function parameter with care.

INDICATION AND DISPLAY OF PROTECTIVE FUNCTION

If a protective function is activated,

- ALARM lamp lights, and
- Alarm information is displayed on the readout of parameter unit (for details, refer to the description of "PARAMETER UNIT") . (p. 92)

HOW TO RESET THE INVERTER

If a protective function is activated, the inverter output is shut off (held shut off) and the motor stops after coasting.

To resume operation, the inverter should be reset by turning off and then on again, or short-circuit between RESET terminals (RES and SD) for at least 0.1sec.

If terminals (RES and SD) are held closed, "Err." appears (flickering) in the readout of the parameter unit, indicating that the inverter is in a reset condition. Do not switch on and off repeatedly by the mains unit.

HOW TO HOLD AN ALARM OUTPUT SIGNAL

If the magnetic contactor on the power input side of the inverter is opened when a protective function is actuated, the control circuit of inverter is shut off from the power supply and the alarm signal cannot be held on.

To hold an alarm signal, an external circuit which holds an alarm signal is used, or a separate power supply is provided for the control circuit (refer to 4. WIRING, (5)) .

ALARM HISTORY

The alarm information is stored in the memory (E²ROM) of inverter, and not erased even when the power is turned off.

Since a maximum of 4 alarms can be stored in the memory, they can be read one by one to identify the cause (for details, refer to the description of "PARAMETER UNIT"). (p. 89)

§ 8. SPECIFICATIONS

8.1 Block diagram

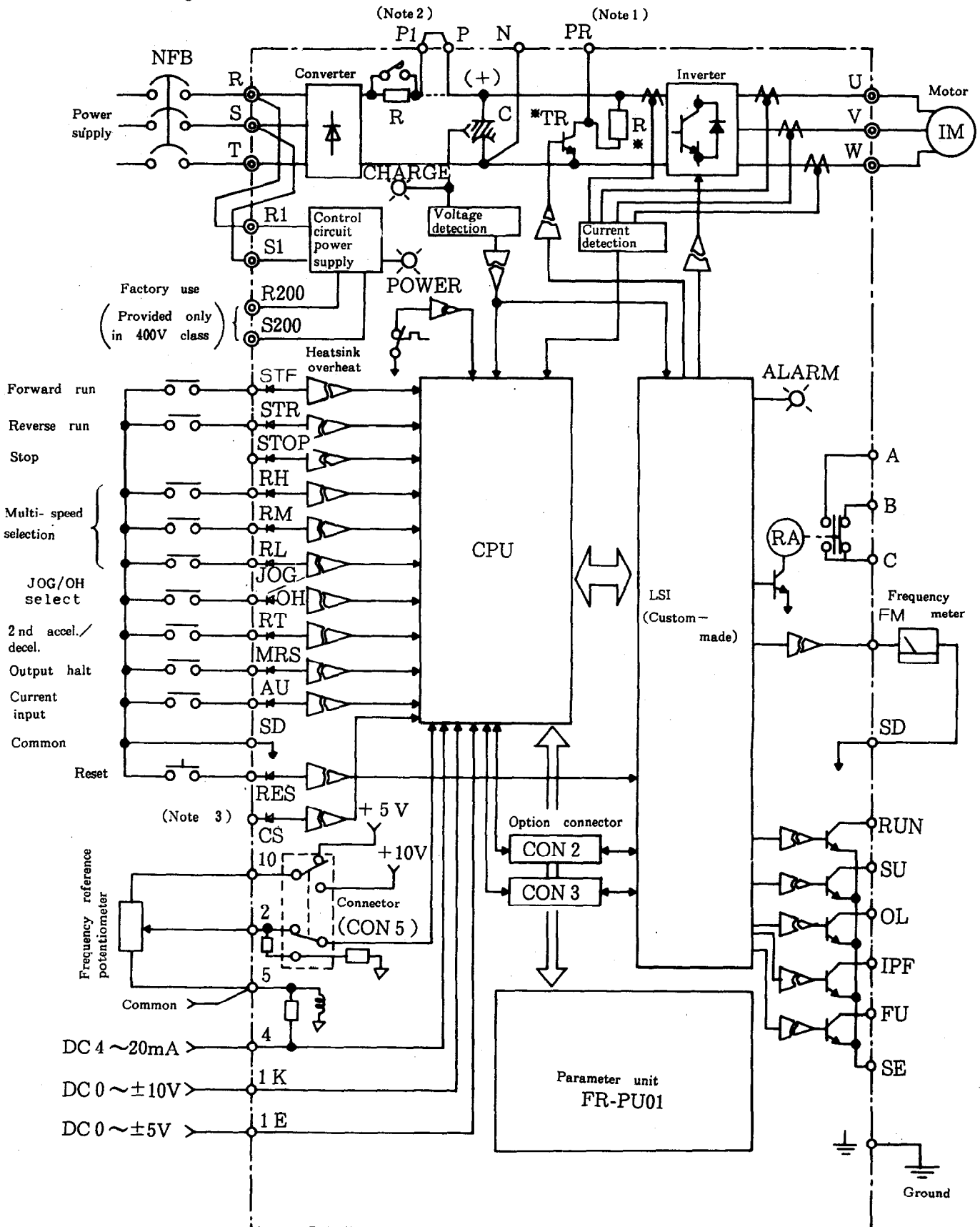

Notes: 1. Terminal PR is provided in FR-Z220-0.4K to 7.5K, and FR-Z240-2.2K to 7.5K.

2. Terminal P1 is provided in FR-Z220-5.5K to 55K, and FR-Z240-5.5K to 55K.
3. Terminal CS is provided in models larger than FR-Z220-15K and FR-Z240-11K.
- *4. For models larger than 11K, built-in regenerative brake resistor and brake transistor are not installed in the inverter. Fit "BU" brake option externally on these larger models.
See page 53. P, P1, PR, N.

8.2 Terminals

	Symbol	Terminal name	Description
Main circuit	R,S,T	AC power supply input terminals	Connected to commercial power supply
	U,V,W	Inverter output terminals	Connected to three-phase squirrel-cage motor
	P,P1,PR,N	Converter output terminals	Connected to optional BU type brake unit (terminals P and N) or external regenerative brake resistor (terminals P and PR)
	R1,S1	Control power supply terminals	Connected to power supply terminals (R and S) in the inverter. When it is desirable to hold alarm display, remove jumper wire from terminals R and S and connect external power supply to these terminals.
		Ground terminal	Inverter chassis grounding terminals
Control circuit (input signals)	STF	Forward start input signal terminal	Motor starts rotating in forward direction (normal run) when STF and SD are short-circuited.
	STR	Reverse start input signal terminal	Motor starts rotating in reverse direction when STR and SD are short-circuited.
	STOP	Start signal self-hold terminal	Start signal can be self-held when STOP and SD are short-circuited. (p. 13)
	RH,RM,RL	Multi-speed select terminals	A speed range can be selected from 7 different preset speed ranges. (p. 103)
	JOG/OH	JOG mode select or external thermal	JOG operation mode is selected when JOG and SD are short-circuited. To start and stop in JOG, use signals STF and STR. (p. 106)

Symbol	Terminal name	Description
JOG/OH (Continued)		With external relay, it is possible to stop inverter operation by a thermal contact input signal.
RT	2nd acceleration/ deceleration time select terminal	2nd acceleration/deceleration time can be selected by short-circuiting between RT and SD.
MRS	Inverter output shutoff, input terminal	Shuts off transistor base current (inverter output) to stop motor by means of magnetic brake, etc. Inverter output is shut off when MRS and SD are short-circuited.
RES	Reset signal, input terminal	To reset inverter after tripping, RES and SD are short-circuited for more than 0.1sec.
AU	Current frequency reference signal select terminal	When AU and SD are short-circuited, DC current ranging from 4mA to 20mA can be used as frequency reference signal.
CS	Instantaneous stop, restart select terminal	When CS and SD are held short-circuited, operation is restarted automatically after restoration following a power failure. (p. 12)
SD	Common terminal for contact input	Common to contact input signal and frequency indication Insulated from common circuit of inverter control circuit
10	Power supply terminal for frequency reference	DC 5V or DC10V (selestable by changing position of connector). See p. 23. Permissible maximum load current: 10mA
2	Frequency reference input signal	When 0 to 5V signal (or 0 to 10V) is input, the output frequency is at a maximum at 5V (or 10V) of input voltage.

Control circuit (input signals)

Symbol	Terminal name	Description
2 (Continued)		The output frequency is directly proportional to the input frequency reference signal voltage. The frequency reference signal voltage is within range from 0V to 5V when connector (CON5) is engaged to "5V", and within range from 0V to 10V when engaged to "10V". See p.23. Input resistance: 10kohm
5	Common terminal for frequency reference	Common to frequency reference input signal Not insulated from common circuit of the control circuit Do not ground this terminal.
1K	Auxiliary frequency reference input signal terminal	When DCO to $\pm 10V$ is input, the output frequency becomes maximum at $\pm 10V$ (or $-10V^*$). The output frequency is proportional to the input frequency reference signal voltage. The signal is added to signal on terminal 2. Input resistance: 10kohm
1E	Auxiliary frequency reference input signal terminal	When DCO to $\pm 5V$ is input, the output frequency reaches a maximum at $+5V$ (or $-5V^*$). The output frequency is proportional to the frequency reference signal voltage. The signal is added to reference on terminal 2. Input resistance: 10kohm
4	Current frequency reference input signal terminal	Current signal ranging from DC 4mA to 20mA is input. Input resistance: 250ohm

Control circuit (output signals)

Symbol	Terminal name	Description
A,B,C	Alarm signal output terminal	Integrated Circuit contact signal which indicates that a protective function of the inverter has activated and inverter output is shut off. Output from B and C is closed (A-C open) when operation is normal, and output from B and C is open (A-C closed) when a protective function is activated. Contact capacity: AC230V 0.3A, DC30V 0.3A
RUN	Inverter "RUN" status output signal terminal IC signal	The signal is "L" level when inverter output frequency is higher than start frequency, and "H" level without output and during DC dynamic brake operation (open collector output)
SU	Up-to-frequency signal terminal (Up to pre-set speed) IC signal	The signal is "L" when inverter output frequency reaches the range of $\pm 10\%$ (initial setting) of preset frequency (may be changed by user). The signal is "H" during acceleration deceleration, or stopped (open collector output).
OL	Overload alarm signal terminal IC signal	The signal falls to "L" level if current exceeds the preset value and the stall preventive function is activated. The signal is "H" when the stall prevention function is reset (open collector output).
IPF	Instantaneous power failure signal terminal IC signal	The signal falls to "L" level if instantaneous power failure or undervoltage alarm occurs (open collector output).
FU	Output frequency detection signal terminal IC signal	The signal falls to "L" level if inverter output frequency exceeds frequency level wrezet by user.

Control circuit (output signals)

	Symbol	Terminal name	Description
Control circuit (output signals)	FU (Continued)		The signal is "H" when inverter output frequency is lower than the preset frequency level (open collector output).
	SE	Common terminal for open collector output IC signal	This terminal is common to signals RUN,SU, OL,IPF and FU, and insulated from common control circuit.
	FM	Terminal for frequency indicator and digital counter	When inverter is shipped, the signal is set so that about DC 5 V (FM-SD opened) is output when inverter output frequency is 60Hz. The output voltage is proportional to the output frequency, and has pulse train waveform. Initial setting: 1440Hz/60Hz

*When function No.41 is set to "1" for forward and reverse operation with analog speed reference signal, the inverter output frequency becomes maximum when signal voltage is -5 V (or -10V).

Note 1 : The rated voltage and current of open collector output are DC24V and 0.1A respectively.

8.3 Standard specifications

Voltage class		200V														
Model FR-Z220-		FR-Z220														
		-0.4K	-0.75K	-1.5K	-2.2K	-3.7K	-5.5K	-7.5K	-11K	-15K	-22K	-30K	-37K	-45K	-55K	
Applicable motor capacity HP (kW)		1/2 (0.4)	1 (0.75)	2 (1.5)	3 (2.2)	5 (3.7)	7.5 (5.5)	10 (7.5)	15 (11)	20 (15)	25 (18.5)/ 30 (22)	40 (30)	50 (37)	60 (45)	75 (55)	
Output ratings	Nominal output (kVA)	1.1	1.9	3.1	4.2	6.5	9.2	12.6	17.6	23.3	34	44	55	67	82	
	Output current (A)	3	5	8	11	17	24	33	46	61	90	115	145	175	215	
	Maximum output voltage (*1)	Three-phase, 200V 50Hz, 200/220/230V 60Hz														
Power supply	AC voltage and frequency	Three-phase, 200V 50Hz, 200/220/230V 60Hz														
	Permissive voltage regulation	180 - 220V 50Hz, 180 - 253V 60Hz														
	Permissive frequency regulation	± 5%														
	Power supply capacity (kVA) (*2)	1.5	2.5	4.5	5.5	9	12	17	20	28	34/41	52	66	80	100	
Controller specification	Control method	Sinusoidal wave PWM control														
	Frequency range	0.5 - 360Hz (starting frequency : 0.5 - 10Hz, adjustable)														
	Frequency resolution	Digital input	0.01Hz (less than 100Hz) , 0.1Hz (more than 100Hz) when parameter unit is used.													
		Analog input	1/1000 of maximum frequency													
	Frequency accuracy	Digital setting	Max. 0.01% of preset output frequency (when set by parameter unit)													
		Analog setting	Max. ±0.5% of maximum output frequency (at 25°C±10°C)													
Voltage/frequency characteristics		Base frequency selectable within 50Hz - 360Hz Constant torque or reduced torque pattern is selectable.														

Voltage class		200V													
Model FR-Z220-		FR-Z220													
		-0.4K	-0.75K	-1.5K	-2.2K	-3.7K	-5.5K	-7.5K	-11K	-15K	-22K	-30K	-37K	-45K	-55K
Controller specification	Torque boost		Manual and automatic torque boost												
	Braking torque	Regenerative brake	Min. 150% (short time)			Min. 100% (short time)			Capacitor charge (min. 20%*3)						
		DC dynamic brake	Operating frequency (0 - 60Hz), operating time (0 - 10sec), voltage (torque) adjustable												
	Stall preventive function threshold current		Threshold current can be set.												
	Rated overload current		150% for 1min., 200% for 0.5sec.												
Operational specification	Frequency reference signal		DC 0 - 5V, 0 - 10V, 4 - 20mA Auxiliary frequency reference signal: DC 0 - ±5V, 0 - ±10V												
	Start signal		Independent "forward start" and "reverse start", and start signal self-holding (3-wire input) are applicable.												
	Acceleration/deceleration time		0.1 - 3600sec. (acceleration and deceleration and times can be set independently)												
	2nd acceleration/deceleration time		0.1 - 3600sec. (acceleration and deceleration and times are set identically)												
	Acceleration/deceleration pattern		"Linear pattern" or "S pattern" can be selected.												
	Multi-speed setting		Maximum 7 speed ranges can be set (adjustable within range from 0Hz to 360Hz in each speed range)												
	Maximum and minimum frequency limit setting		Maximum frequency limit adjustable range: 0 - 360Hz Maximum frequency limit adjustable range: 0 - 60Hz												
JOG mode operation		JOG mode select terminal is available (*4).													
Reset signal		External reset signal input terminal is available.													

Voltage class		200V													
Model FR-Z220-		FR-Z220													
		-0.4K	-0.75K	-1.5K	-2.2K	-3.7K	-5.5K	-7.5K	-11K	-15K	-22K	-30K	-37K	-45K	-55K
Output rating	Output halt signal	Output halt input signal terminal is available.													
	Operation status output signals	"RUN", "SU" (up-to-frequency), "ON" (overload), "IPF" (instantaneous power failure) and "FU" (frequency detection) signals													
	Alarm output signal	1C relay contact signal (AC 230V 0.3A, DC 30V 0.3A)													
Protective, alarm and warning functions		Overcurrent shutoff (during acceleration, deceleration and normal operation), regenerative overvoltage shutoff, undervoltage protection, instantaneous power failure protection, overload shutoff (electronic terminal relay), brake transistor fault detection (*5), ground overcurrent protection, output short-circuit protection, heatsink overheat protection (*6), brake regenerative resistor overheat protection (*5), stall prevention and overload alarm													
Environment	Ambient temperature	-10°C to +50°C (to be free from freezing)													
	Ambient humidity	90%RH or less (to be free from condensation)													
	Storage temperature (*7)	-20°C to +65°C													
	Atmosphere	Indoor To be free from corrosive gases and dense dust													
	Altitude, vibration	Below 1000m (3300ft) 0.6G or less (conforms to JIS CO911)													
Built-in optional units		Maximum 2 cards can be used.													
Protective structure (JEM 1030)		Enclosed type (IP20)							Open type (IP00)						
Weight (kg)	kg (Lb)	2.9 (6.39)	3.2 (7.05)	3.5 (7.72)	6.1 (13.45)	6.4 (14.11)	9.0 (19.84)	9.5 (20.94)	12 (26.46)	20 (44.09)	28 (61.73)	33 (72.75)	45 (99.21)	60 (132.28)	65 (143.30)

- Notes :
- * 1. If the line voltage decreases, output voltage over the line voltage cannot be guaranteed.
 - * 2. Power supply capacity indicates the inverter input kVA and may change depending on power supply impedance (including input reactor).
 - * 3. This value may depend on motor loss.
 - * 4. JOG operation can be controlled not only with signal on JOG mode select terminal, but also parameter unit.
 - * 5. This function is not provided for models FR-Z200-11K to 55K, and FR-Z240-11K to 55K.

Voltage class		400V										
Model FR-Z240-		FR-Z240										
		-2.2K	-3.7K	-5.5K	-7.5K	-11K	-15K	-22K	-30K	-37K	-45K	-55K
Applicable motor capacity HP (kW)		3 (2.2)	5 (3.7)	7.5 (5.5)	10 (7.5)	15 (11)	20 (15)	25 (18.5)/ 30 (22)	40 (30)	50 (37)	60 (45)	75 (55)
Output ratings	Nominal output (kVA)	4.2	6.9	9.9	13	17.5	23.6	32.8	43.4	54	65.5	84
	Output current (A)	6	9	13	17	23	31	43	57	71	86	110
	Maximum output voltage (*1)	Three-phase, 400V 50Hz, 400/440/460V 60Hz										
Power supply	AC voltage and frequency	Three-phase, 400V 50Hz, 400/440/460V 60Hz										
	Permissive voltage regulation	360 - 440V 50Hz, 360 - 506V 60Hz										
	Permissive frequency regulation	± 5 %										
	Power supply capacity (kVA) (*2)	5.5	9	12	17	20	28	34/41	52	66	80	100
Controller specification	Control method		Sinusoidal wave PWM control									
	Frequency range		0.5 - 360Hz (starting frequency: 0.5 - 10Hz, adjustable)									
	Frequency resolution	Digital input	0.01Hz (less than 100Hz), 0.1Hz (more than 100Hz) ...when parameter unit is used.									
		Analog input	1/1000 of maximum frequency									
	Frequency accuracy	Digital setting	Max. 0.01% of preset output frequency (when set by parameter unit)									
		Analog	Max. ±0.5% of maximum output frequency (at 25°C±10°C)									
Voltage/frequency characteristics		Base frequency selectable within 50Hz - 360Hz Constant torque or reduced torque pattern is selectable.										

Voltage class		400V										
Model FR-Z240-		FR-Z240										
		-2.2K	-3.7K	-5.5K	-7.5K	-11K	-15K	-22K	-30K	-37K	-45K	-55K
Controller specification	Torque boost		Manual and automatic torque boost									
	Braking torque	Regenerative brake	Min. 100% (short time)				Capacitor charge (min. 20%*3)					
		DC dynamic brake	Operating frequency (0 - 60Hz), operating time (0 - 10sec), voltage (torque) adjustable									
	Stall preventive function threshvld current		Threshold current can be set.									
	Rated overload current		150% for 1 min., 200% for 0.5sec									
Operational specification	Frequency reference signal		DC 0 - 5V, 0 - 10V, 4 - 20mA Auxiliary frequency reference signal: DC 0 - ±5V, 0 - ±10V									
	Start signal		Independent "forward start" and "reverse start", and start signal self-holding (3-wire input) are applicable.									
	Acceleration/deceleration time		0.1 - 3600sec. (acceleration and deceleration times can be set independently)									
	2nd acceleration/deceleration time		0.1 - 3600sec. (acceleration and deceleration times are set identically)									
	Acceleration/deceleration pattern		"Linear pattern" or "S pattern" can be selected.									
	Multi-speed setting		Maximum 7 speed ranges can be set (adjustable within range from 0Hz to 360Hz in each speed range)									
	Maximum and minimum frequency limit setting		Maximum frequency limit adjustable range: 0 - 360Hz Maximum frequency limit adjustable range: 0 - 60Hz									
	JOG mode operation		JOG mode select terminal is available (*4).									
	Frequency jump		Maximum three frequency jump zones can be set.									
Reset signal		External reset signal input terminal is available.										

Voltage class		400V										
Model FR-Z240-		FR-Z240										
		-2.2K	-3.7K	-5.5K	-7.5K	-11K	-15K	-22K	-30K	-37K	-45K	-55K
Output rating	Output halt signal	Output halt input signal terminal is available.										
	Operation status output signals	"RUN", "SU" (up-to-frequency), "OL" (overload), "IPF" (instantaneous power failure) and "FU" (frequency detection) signals										
	Alarm output signal	IC relay contact signal (AC230V 0.3A, DC30V 0.3A)										
Protective, alarm and warning functions		Overcurrent shutoff (during acceleration, deceleration and normal operation), regenerative overvoltage shutoff (electronic terminal relay), brake transistor fault detection (*5), ground fault overcurrent protection, heatsink overheat protection, brake regenerative resistor overheat protection (*5), stall prevention and overload alarm										
Environment	Ambient temperature	-10°C to +50°C (to be free from freezing)										
	Ambient humidity	90%RH or less (to be free from condensation)										
	Storage temperature (*6)	-20°C to +65°C										
	Atmosphere	Indoor To be free from corrosive gases and dense dust										
	Altitude, vibration	Below 1000m (3300ft) 0.6G or less (conforms to JIS C0911)										
Built-in optional units		Maximum 2 cards can be used.										
Protective structure (JEM 1030)		Enclosed type (IP20)					Open type (IP00)					
Weight kg (Lb)		10.5 (23.15)	11 (24.25)	12 (26.46)	25 (55.12)		29 (63.93)		47 (103.62)		71 (156.53)	

Notes : *6. This function is not provided in models FR-Z220-0.4K to 1.5K having no cooling fan.

*7. This is "short-time storage temperature" (during transport, for example).

8.4 External dimensions

Dimension in mm

FR-Z220-0.4K(P)~3.7K(P) [200V class]

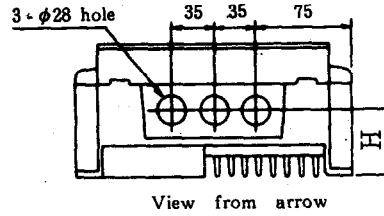
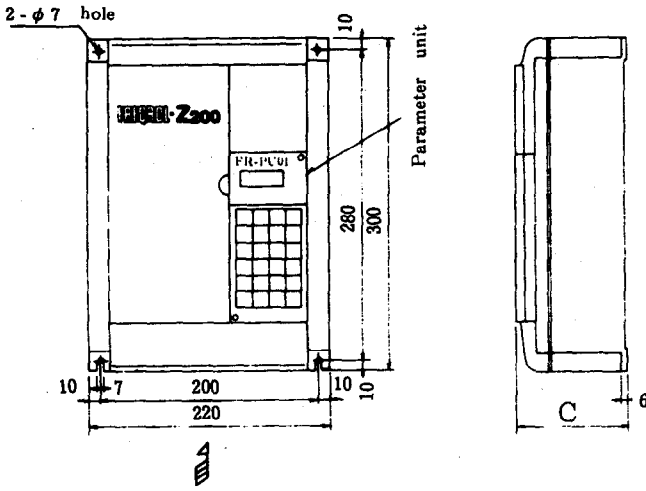

●200V class

Inverter model	C	H
FR-Z220-0.4K(P)	110	50
FR-Z220-0.75K(P)	140	80
FR-Z220-1.5K(P)	140	80
FR-Z220-2.2K(P)	170	110
FR-Z220-3.7K(P)	170	110

Note: Models FR-Z220-0.4K to 1.5K are not equipped with cooling fan.

FR-Z220-5.5K(P)~-11K [200V class]、FR-Z240-2.2K(P)~-7.5K(P) [400V class]

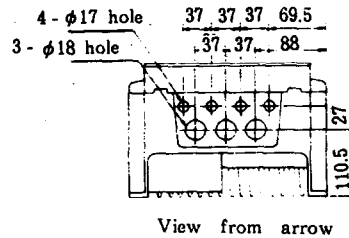
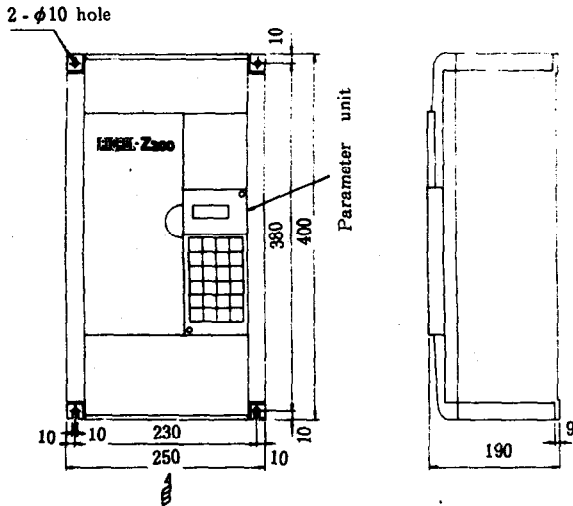

●200V class

Inverter model
FR-Z220-5.5K(P)
FR-Z220-7.5K(P)
FR-Z220-11K

●400V class

Inverter model
FR-Z240-2.2K(P)
FR-Z240-3.7K(P)
FR-Z240-5.5K(P)
FR-Z240-7.5K(P)

FR-Z220-15K~55K [200V class]、FR-Z240-11K~55K [400V class]

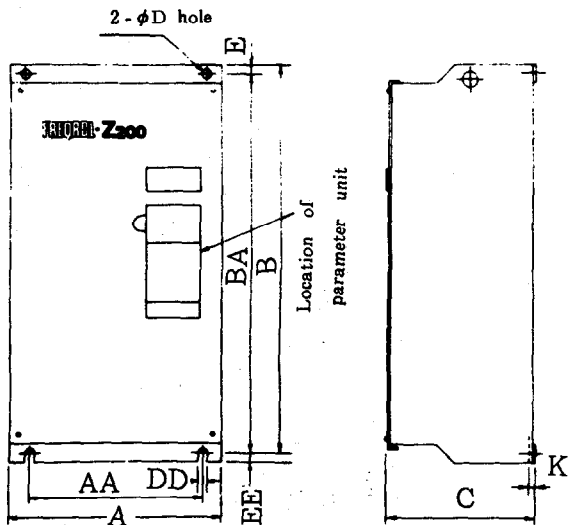

●200V class

Inverter model	A	AA	B	BA	C	D	DD	E	EE	K
FR-Z220-15K	280	230	530	510	195	10	10	10	10	6
FR-Z220-22K	340	290	595	570	195	12	12	15	10	6
FR-Z220-30K	340	290	695	670	195	12	12	15	10	6
FR-Z220-37K	480	420	745	720	250	14	14	15	10	8
FR-Z220-45K	480	420	885	860	250	14	14	15	10	8
FR-Z220-55K	480	420	885	860	250	14	14	15	10	8

●400V class

Inverter model	A	AA	B	BA	C	D	DD	E	EE	K
FR-Z240-11K,15K	340	290	595	570	195	12	12	15	10	8
FR-Z240-22K,30K	340	290	595	570	195	12	12	15	10	8
FR-Z240-37K,45K	480	420	745	720	250	14	14	15	10	8
FR-Z240-55K	480	420	885	860	250	14	14	15	10	8

8.5 Selection of peripheral devices

Voltage	Motor output (kW)	Applicable inverter model	No-fuse breaker (NFB)				Magnetic contactor (MC)
			Standard		Equipped with AC reactor		
200V class	0.4	FR-Z220-0.4K	NF30	5A	NF30	5A	S-K10
	0.75	FR-Z220-0.75K	NF30	10A	NF30	10A	S-K10
	1.5	FR-Z220-1.5K	NF30	15A	NF30	15A	S-K10
	2.2	FR-Z220-2.2K	NF30	20A	NF30	15A	S-K11、K12
	3.7	FR-Z220-3.7K	NF30	30A	NF30	30A	S-K20
	5.5	FR-Z220-5.5K	NF50	50A	NF50	40A	S-K25
	7.5	FR-Z220-7.5K	NF100	60A	NF50	50A	S-K35
	11	FR-Z220-11K	NF100	75A	NF100	75A	S-K50
	15	FR-Z220-15K	NF225	125A	NF100	100A	S-K65
	18.5	FR-Z220-22K	NF225	150A	NF225	125A	S-K80
	22	FR-Z220-22K	NF225	175A	NF225	150A	S-K95
	30	FR-Z220-30K	NF225	225A	NF225	175A	S-K125
	37	FR-Z220-37K	NF400	250A	NF225	225A	S-K150
	45	FR-Z220-45K	NF400	300A	NF400	300A	S-K180
	55	FR-Z220-55K	NF400	400A	NF400	350A	S-K220
400V class	1.5	FR-Z240-2.2K	NF30	10A	NF30	10A	S-K20
	2.2	FR-Z240-2.2K	NF30	15A	NF30	10A	S-K20
	3.7	FR-Z240-3.7K	NF30	20A	NF30	15A	S-K20
	5.5	FR-Z240-5.5K	NF30	30A	NF30	20A	S-K20
	7.5	FR-Z240-7.5K	NF30	30A	NF30	30A	S-K20
	11	FR-Z240-11K	NF50	50A	NF50	40A	S-K20
	15	FR-Z240-15K	NF100	60A	NF50	50A	S-K25
	18.5	FR-Z240-22K	NF100	75A	NF100	60A	S-K35
	22	FR-Z240-22K	NF100	90A	NF100	75A	S-K50
	30	FR-Z240-30K	NF225	125A	NF100	100A	S-K65
	37	FR-Z240-37K	NF225	150A	NF225	125A	S-K80
	45	FR-Z240-45K	NF225	175A	NF225	150A	S-K80
55	FR-Z240-55K	NF225	200A	NF225	175A	S-K100	

Notes: 1. The interrupting capacity of NFB (no-fuse breaker) should be selected in accordance with power supply capacity.

8.6 Drip shield kits

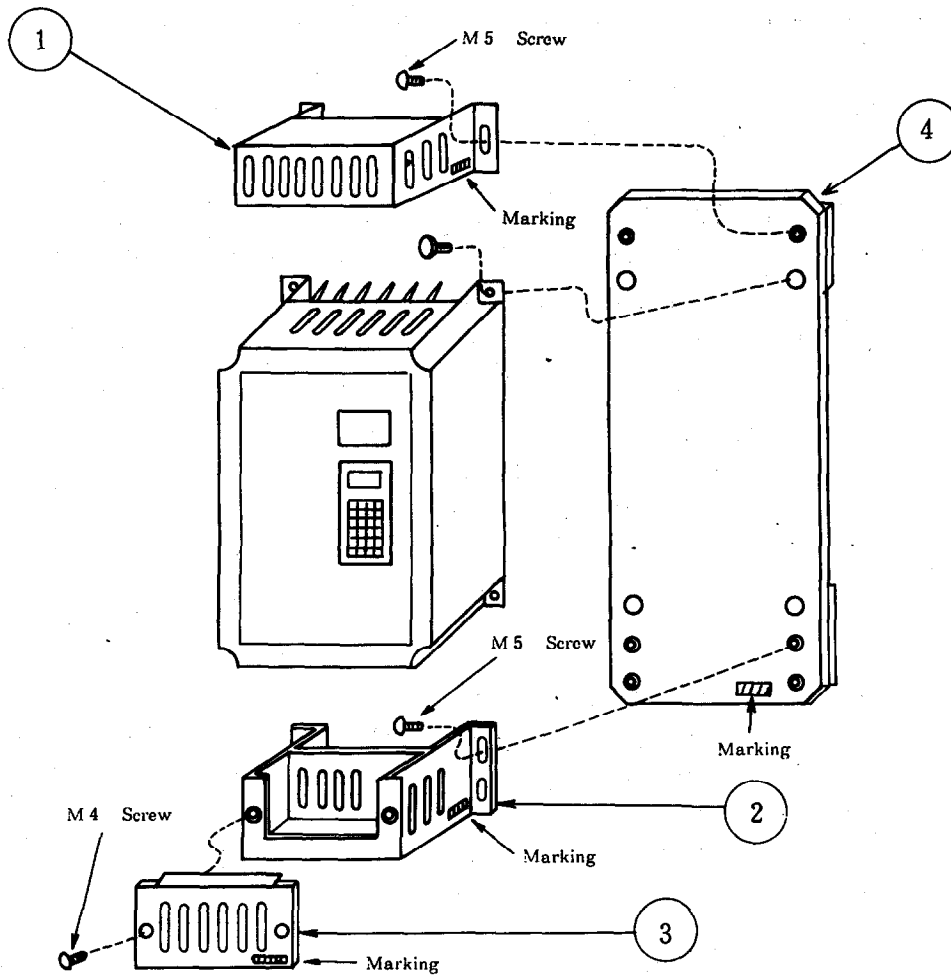

Marking : Part No is stamped.

Inverter type	CAT.No	Part No			
		①	②	③	④
FR-Z220-0.4K	TD840A662G51	D784C008G51	D784C009G51	D785C020H01	D783C500G51
FR-Z220-0.75K	TD840A662G52	D784C008G52	D784C009G52	D785C020H01	D783C500G51
FR-Z220-1.5K	TD840A662G52	D784C008G52	D784C009G52	D785C020H01	D783C500G51
FR-Z220-2.2K	TD840A662G53	D784C008G53	D784C009G53	D785C020H01	D783C500G51
FR-Z220-3.7K	TD840A662G53	D784C008G53	D784C009G53	D785C020H01	D783C500G51
FR-Z220-5.5K	TD840A662G54	D784C010G51	D784C011G51	D785C020H02	D783C501G51
FR-Z220-7.5K	TD840A662G54	D784C010G51	D784C011G51	D785C020H02	D783C501G51
FR-Z220-11K	TD840A662G54	D784C010G51	D784C011G51	D785C020H02	D783C501G51
FR-Z240-2.2K	TD840A662G54	D784C010G51	D784C011G51	D785C020H02	D783C501G51
FR-Z240-3.7K	TD840A662G54	D784C010G51	D784C011G51	D785C020H02	D783C501G51
FR-Z240-5.5K	TD840A662G54	D784C010G51	D784C011G51	D785C020H02	D783C501G51
FR-Z240-7.5K	TD840A662G54	D784C010G51	D784C011G51	D785C020H02	D783C501G51

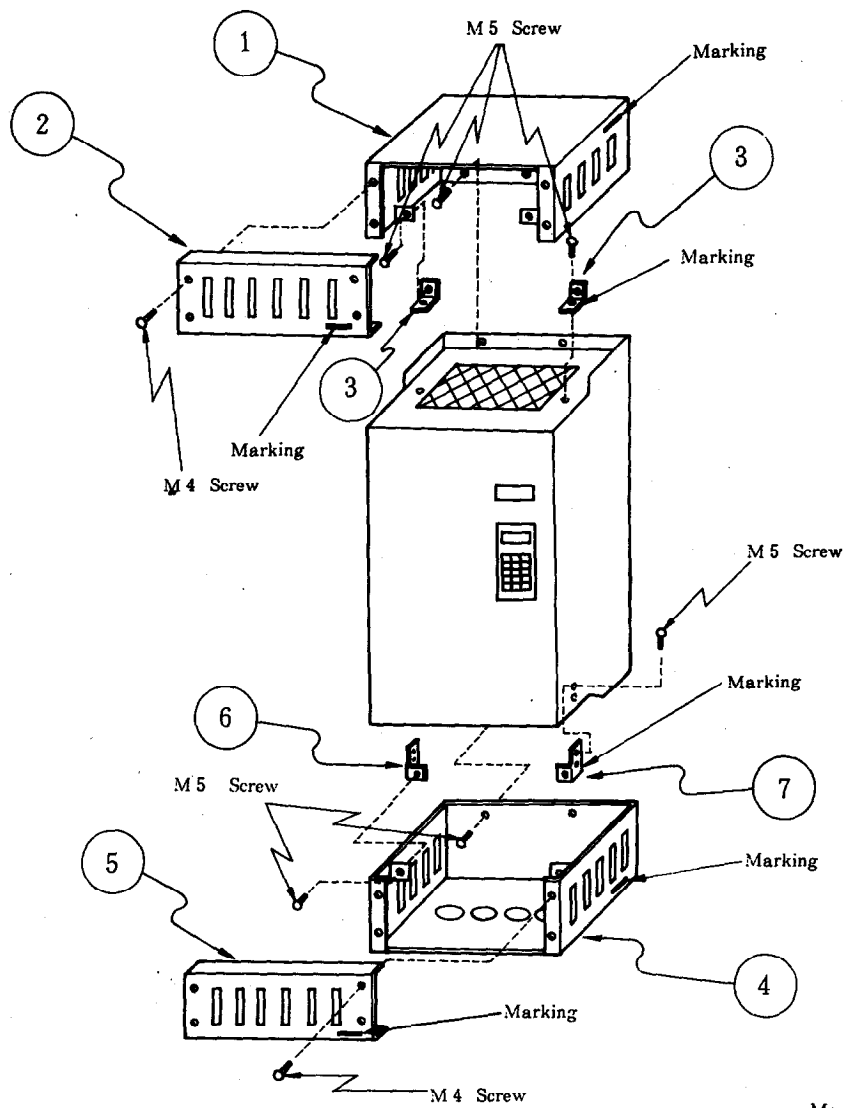

Marking : Part No. is stamped.

Inverter type	CAT.No.	Part No.						
		①	②	③ (× 2)	④	⑤	⑥	⑦
FR-Z220-15K	TD840A663G51	D714C569G51	D708C556H04	D811C138H01	D714C569G54	D708C556H04	D811C138H03	D811C138H04
FR-Z220-22K	TD840A663G52	D714C569G52	D708C556H02	D811C138H01	D714C569G55	D708C556H05	D811C138H03	D811C138H04
FR-Z220-30K	TD840A663G52	D714C569G52	D708C556H02	D811C138H01	D714C569G55	D708C556H05	D811C138H03	D811C138H04
FR-Z220-37K	TD840A663G54	D714C569G53	D708C556H03	D811C138H01	D714C569G58	D708C556H07	D811C138H05	D811C138H05
FR-Z220-45K	TD840A663G54	D714C569G53	D708C556H03	D811C138H01	D714C569G58	D708C556H07	D811C138H05	D811C138H05
FR-Z220-55K	TD840A663G54	D714C569G53	D708C556H03	D811C138H01	D714C569G58	D708C556H07	D811C138H05	D811C138H05
FR-Z240-11K	TD840A663G52	D714C569G52	D708C556H02	D811C138H01	D714C569G55	D708C556H05	D811C138H03	D811C138H04
FR-Z240-15K	TD840A663G52	D714C569G52	D708C556H02	D811C138H01	D714C569G55	D708C556H05	D811C138H03	D811C138H04
FR-Z240-22K	TD840A663G52	D714C569G52	D708C556H02	D811C138H01	D714C569G55	D708C556H05	D811C138H03	D811C138H04
FR-Z240-30K	TD840A663G52	D714C569G52	D708C556H02	D811C138H01	D714C569G55	D708C556H05	D811C138H03	D811C138H04
FR-Z240-37K	TD840A663G53	D714C569G53	D708C556H03	D811C138H01	D714C569G56	D708C556H06	D811C138H05	D811C138H05
FR-Z240-45K	TD840A663G53	D714C569G53	D708C556H03	D811C138H01	D714C569G56	D708C556H06	D811C138H05	D811C138H05
FR-Z240-55K	TD840A663G53	D714C569G53	D708C556H03	D811C138H01	D714C569G56	D708C556H06	D811C138H05	D811C138H05

8.7 Overload protection

External overload protection must be provided to protect the motor in accordance with the National Electrical Code.

Note: The drive is suitable for use on a circuit capable of delivering 10,000 RMS Symmetrical Amps.

PARAMETER UNIT

PARAMETER UNIT

Parameter unit, model FR-PU01E, is directly attached to the inverter (FR-Z series), or connected to the inverter with the cable (option).

The parameter unit permits the operator to set (read and write) various control variable (parameters), and to monitor operation status through its readout.

In this manual, parameter unit is abbreviated as "PU".

§ 1. INSTALLATION

The PU can be directly attached to the inverter, or remotely installed and connected to the inverter with the approved cable. It can be attached or connected even when the inverter is operating.

● Direct attachment to inverter

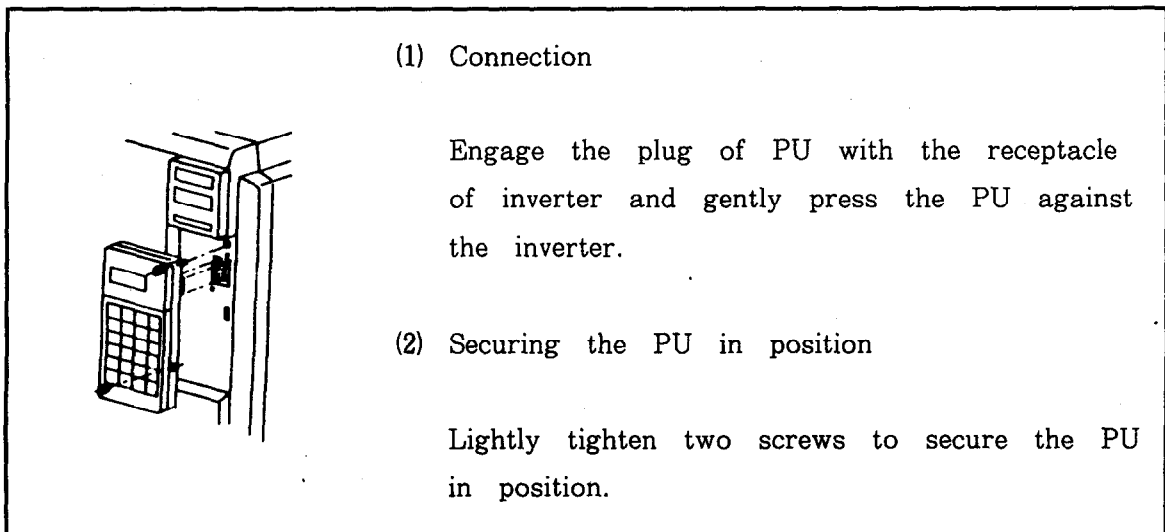

CAUTION: (1) The PU should be attached to the inverter with the front cover installed on the inverter.

(2) Never operate the inverter with the PU with the front cover removed. To prevent accidental damage to the inverter P.C.B and the PU unit.

(3) If the inverter must be operated with the front cover removed, always use the approved extension cable with the PU unit.

(4) Dangerous high voltages are present inside the inverter. Always use with great care and attention.

○Remote installation using the approved cable connector

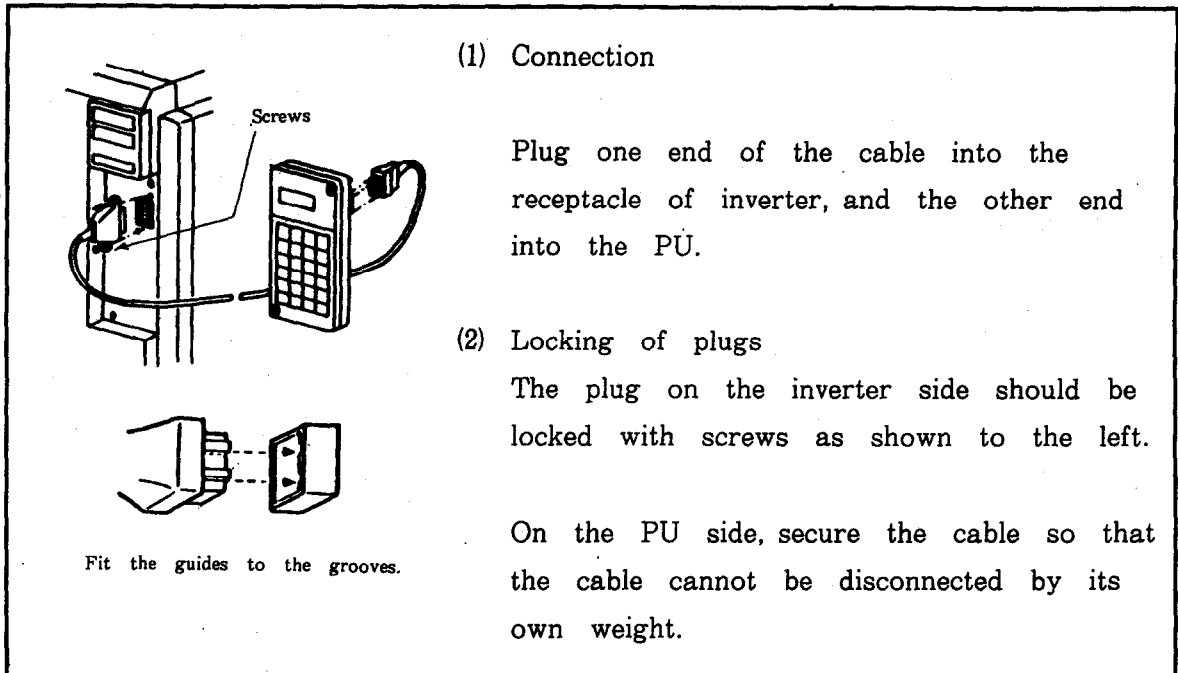

CAUTION: (1) For cable, use only that specified by us (available as optional accessory) .

(2) The cable plugs and sockets only fit in one position. Do not force plugs into sockets.

§ 2. OUTLINE OF FUNCTIONS

Function	Description		Refer to
Selection of operation mode (Parameter mode)	Parameter unit can be used as control source for inverter operation.	Keys of parameter unit are operated.	4.3 Page 78
(External mode)	External signals can be used as control source for inverter operation.	Separately installed frequency reference potentiometer, START switch, etc. are operated.	4.2 Page 77
Setting (read/write) of control variables (Monitor/alter)	Set control variable can be read.	Settings are checked.	5.1 Page 83
	Setting of control variable can be changed.	Change of setting	
	User's settings can be reset to the initial settings (settings made at shipment) "ALL CLEAR".		5.1
	Write parameter can be prohibited.		5.1
	Frequency meter (indicator) can be calibrated.		5.1
Monitor	Operation status can be monitored.	Output frequency (Hz)	§ 6 Page 88
		Motor current (A)	
		Output voltage (V)	
		Speed (rpm)	
		Direction of rotation of motor	
		Motor RUN	
	Alarm information		§ 6, § 7

§ 3. CONTROL DEVICES OF PARAMETER UNIT

"ONLY LIGHT FINGER PRESURE IS NECESSARY"

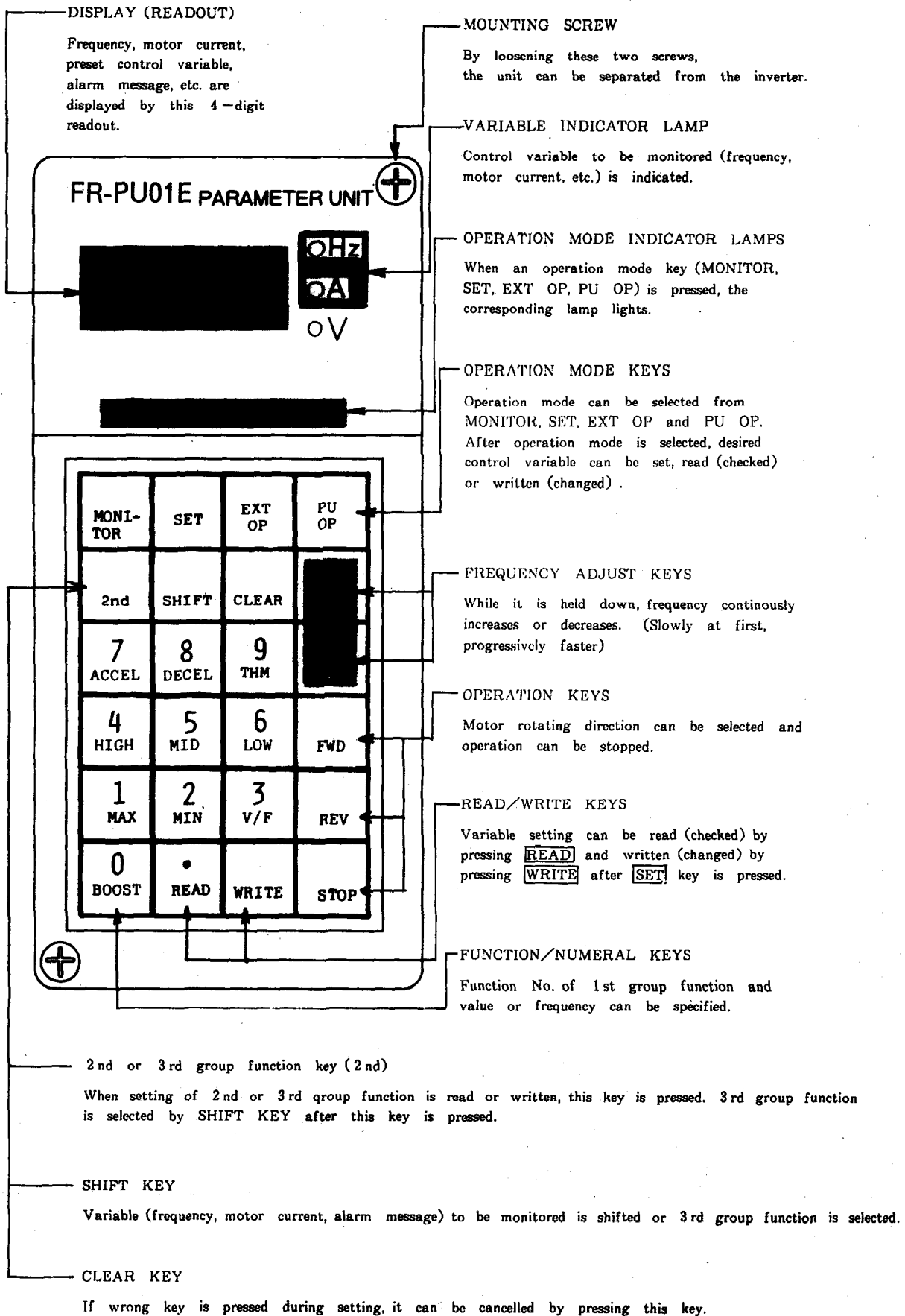

Key	Description
EXT OP	This key is pressed when external signals are used to control the inverter. (Inverter always powers up in this mode)
PU OP	This key is pressed when the PU (parameter unit) is used to control the inverter.
SET	This key is pressed to read (check) or write (change) setting of variable.
MONITOR	This key is pressed to read frequency, motor current, output voltage or alarm message (alarm code) .
2nd	2nd or 3rd group function can be selected.
SHIFT	This key is pressed to change variable to be monitored, to select 3rd group function, or to specify JOG mode.
CLEAR	This key is pressed to correct wrong key operation, or erase previous entry.
▲	During operation with the PU, this key is pressed to increase output frequency.
	During operation with external signals, this key is pressed to increase reading of externally connected frequency meter. (Calibration mode)
▼	During operation with the PU, this key is pressed to decrease output frequency.
	During operation with external signals, this key is pressed to decrease reading of externally connected frequency meter. (Calibration mode)
FWD	During operation with the PU, this key is pressed to make the motor rotate in normal direction.
REV	During operation with the PU, this key is pressed to make the motor rotate in opposite direction.
STOP	During operation with the PU, this key is pressed to stop the motor.
WRITE	This key is pressed to change setting of frequency or other control variable.
• READ	" • " is used to specify decimal point.
	This key is pressed to check setting of variable.

Key	Description (Dual functions)
0 BOOST	" 0 "Numeral " 0 " is specified.
	" BOOST "Variable " BOOST " is selected.
1 MAX	" 1 "Numeral " 1 " is specified.
	" MAX "Variable " MAXIMUM FREQUENCY LIMIT " is specified.
2 MIN	" 2 "Numeral " 2 " is specified.
	" MIN "Variable " MINIMUM FREQUENCY LIMIT " is selected.
3 V/F	" 3 "Numeral " 3 " is specified.
	" V/F "Variable " V/F " (base frequency) is selected.
4 HIGH	" 4 "Numeral " 4 " is specified.
	" HIGH "Variable " HIGH SPEED " is selected.
5 MID	" 5 "Numeral " 5 " is specified.
	" MID "Variable " MIDDLE SPEED " is selected.
6 LOW	" 6 "Numeral " 6 " is specified.
	" LOW " " LOW SPEED " is selected.
7 ACCEL	" 7 "Numeral " 7 " is specified.
	" ACCEL "Variable " ACCELERATION TIME " is selected.
8 DECEL	" 8 "Numeral " 8 " is specified.
	" DECEL "Variable " DECELERATION TIME " is selected.
9 THM	" 9 "Numeral " 9 " is specified.
	" THM "Variable " ELECTRONIC THERMAL RELAY OPERATING CURRENT " is selected.

§ 4. OPERATION

4.1 Operation mode

The inverter can be operated either with external signals, or with PU (parameter unit).

Selection of operation mode (external signal mode or parameter mode) can be made by pressing key of PU.

It is possible to fix operation mode. (FUNCTION 79)

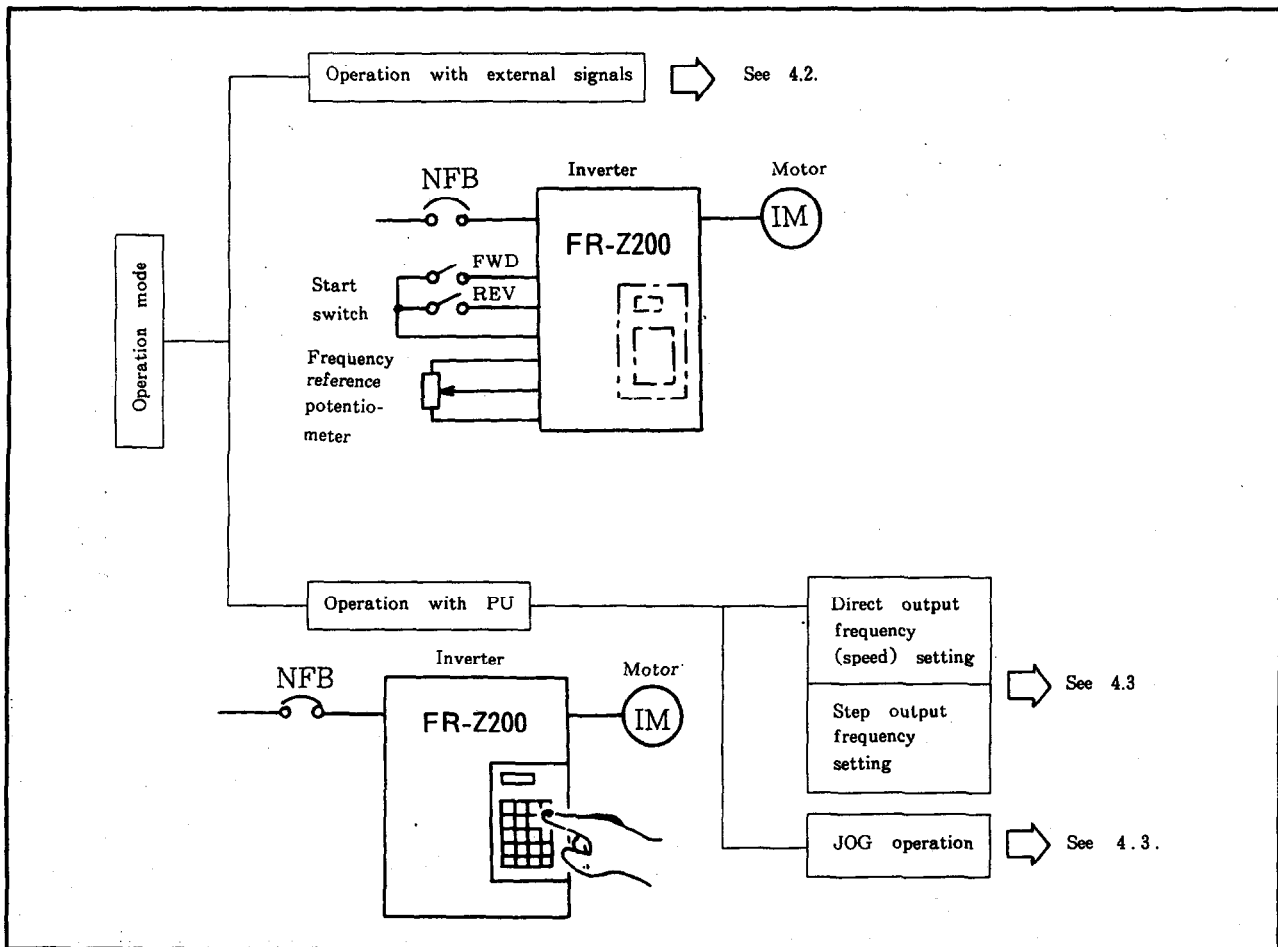

INITIAL OPERATION MODE

When the power is turned on (or CLEAR key is pressed to reset), "external signal operation" mode is automatically selected and the inverter can be operated with external signals

....the motor starts when START signal (STF-SD or STR-SD closed) is given.

HOW TO FIX OPERATION MODE (FUNCTION 79)

Initial setting of operation mode can be changed so that "PU operation" mode is automatically selected whenever the power is turned on.

For details, refer to § 9.

4.2 Operation with external signals

When "PU operation" mode has been selected, press **EXT OP** key to select "external signal operation" mode (check that the indicator lamp of selected operation mode lights).

Example of operation and indication

○ When the inverter is turned on or **EXT OP** key is pressed.....

○ During operation with external frequency reference set at 30Hz.....

Note: ✕ and ○ show that lamp lights and does not light respectively.

✕	○	✕	○
MONI-TOR	SET	EXT OP	PU OP

(1) When "external signal operation" mode is selected, "MONITOR" mode is automatically selected and output frequency is displayed by the readout (see §. 6.).

(2) While inverter output is on (during rotation of the motor), the mode indicator lamp just above **EXT OP** key flickers (the same occurs during DC dynamic brake operation). (Note *)

CAUTION: Changing operation mode from "PU operation" to "External signal operation"

Operation mode cannot be changed when START signal is on (STF - SD or STR - SD is closed).

Before changing operation mode, START signal should be turned off and it should be verified that the motor stops completely.

(Note *) The lamp does not flicker when a parameter unit of old specification (Spec. No. BKO - C2128) is used.

4.3 Operation with PU

To operate the inverter with the PU, press

PU
OP

 key.

After that, the inverter can be started and stopped by pressing keys of PU (without use of externally installed frequency reference potentiometer and START switch).

In this operation mode, it is also possible to jog the motor by pressing keys of PU.

IMPORTANT NOTE

If the inverter is turned off or reset, operation mode changes from "PU operation" to "external signal operation" (initial mode setting).

(1) DIRECT OUTPUT FREQUENCY SETTING

<table border="0" style="width: 100%;"><tr><td style="text-align: center;"><table border="1" style="display: inline-table;"><tr><td>PU</td></tr><tr><td>OP</td></tr></table></td><td style="text-align: center;">·</td><td style="text-align: center;"><table border="1" style="display: inline-table;"><tr><td>Desired frequency</td></tr></table></td><td style="text-align: center;">·</td><td style="text-align: center;"><table border="1" style="display: inline-table;"><tr><td>WRITE</td></tr></table></td><td style="text-align: center;">·</td><td style="text-align: center;"><table border="1" style="display: inline-table;"><tr><td>FWD</td></tr></table> (or <table border="1" style="display: inline-table;"><tr><td>REV</td></tr></table>)</td><td style="text-align: center;">·</td><td style="text-align: center;"><table border="1" style="display: inline-table;"><tr><td>STOP</td></tr></table></td></tr></table>	<table border="1" style="display: inline-table;"><tr><td>PU</td></tr><tr><td>OP</td></tr></table>	PU	OP	·	<table border="1" style="display: inline-table;"><tr><td>Desired frequency</td></tr></table>	Desired frequency	·	<table border="1" style="display: inline-table;"><tr><td>WRITE</td></tr></table>	WRITE	·	<table border="1" style="display: inline-table;"><tr><td>FWD</td></tr></table> (or <table border="1" style="display: inline-table;"><tr><td>REV</td></tr></table>)	FWD	REV	·	<table border="1" style="display: inline-table;"><tr><td>STOP</td></tr></table>	STOP
<table border="1" style="display: inline-table;"><tr><td>PU</td></tr><tr><td>OP</td></tr></table>	PU	OP	·	<table border="1" style="display: inline-table;"><tr><td>Desired frequency</td></tr></table>	Desired frequency	·	<table border="1" style="display: inline-table;"><tr><td>WRITE</td></tr></table>	WRITE	·	<table border="1" style="display: inline-table;"><tr><td>FWD</td></tr></table> (or <table border="1" style="display: inline-table;"><tr><td>REV</td></tr></table>)	FWD	REV	·	<table border="1" style="display: inline-table;"><tr><td>STOP</td></tr></table>	STOP	
PU																
OP																
Desired frequency																
WRITE																
FWD																
REV																
STOP																

(2) OUTPUT FREQUENCY SETTING, USING ▼ OR ▲ KEY (STEP SETTING)

<table border="0" style="width: 100%;"><tr><td style="text-align: center;"><table border="1" style="display: inline-table;"><tr><td>PU</td></tr><tr><td>OP</td></tr></table></td><td style="text-align: center;">·</td><td style="text-align: center;">▲ (or ▼)</td><td style="text-align: center;">·</td><td style="text-align: center;"><table border="1" style="display: inline-table;"><tr><td>WRITE</td></tr></table></td><td style="text-align: center;">·</td><td style="text-align: center;"><table border="1" style="display: inline-table;"><tr><td>FWD</td></tr></table> (or <table border="1" style="display: inline-table;"><tr><td>REV</td></tr></table>)</td><td style="text-align: center;">·</td><td style="text-align: center;"><table border="1" style="display: inline-table;"><tr><td>STOP</td></tr></table></td></tr></table>	<table border="1" style="display: inline-table;"><tr><td>PU</td></tr><tr><td>OP</td></tr></table>	PU	OP	·	▲ (or ▼)	·	<table border="1" style="display: inline-table;"><tr><td>WRITE</td></tr></table>	WRITE	·	<table border="1" style="display: inline-table;"><tr><td>FWD</td></tr></table> (or <table border="1" style="display: inline-table;"><tr><td>REV</td></tr></table>)	FWD	REV	·	<table border="1" style="display: inline-table;"><tr><td>STOP</td></tr></table>	STOP
<table border="1" style="display: inline-table;"><tr><td>PU</td></tr><tr><td>OP</td></tr></table>	PU	OP	·	▲ (or ▼)	·	<table border="1" style="display: inline-table;"><tr><td>WRITE</td></tr></table>	WRITE	·	<table border="1" style="display: inline-table;"><tr><td>FWD</td></tr></table> (or <table border="1" style="display: inline-table;"><tr><td>REV</td></tr></table>)	FWD	REV	·	<table border="1" style="display: inline-table;"><tr><td>STOP</td></tr></table>	STOP	
PU															
OP															
WRITE															
FWD															
REV															
STOP															

This method of setting corresponds to the method where externally installed frequency reference potentiometer is used. While ▲ or ▼ key is held down, frequency increases (or decreases) continuously.

Increase (or decrease) of frequency is slow immediately after key is pressed, and becomes faster with time.

Note: If speed is being monitored, this setting should not be tried (speed may not be displayed accurately).

(3) JOG operation

To jog the motor, perform the following operation:

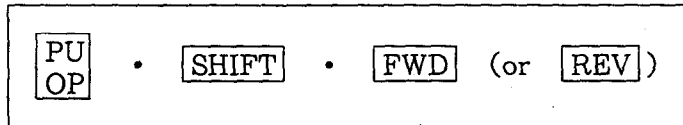

The motor starts and runs only while **FWD** or **REV** key is held down.

- When the motor is started by pressing START key (**FWD** or **REV**), MONITOR mode is selected automatically and output frequency is displayed (Note 1)
- While inverter output is on (during rotation of the motor), the mode indicator lamp just above **PU OP** flickers (the same occurs during DC dynamic brake operation). (Note 2.)

Notes: 1. MONITOR mode is not selected automatically when a parameter unit of previous specification (Spec. No. BKO-C2128) is used.

2. The lamp does not flicker when a parameter unit of previous specification (Spec. No. BKO-C2128) is used.

Examples of operation and indication

○ Example where 60Hz is set for desired output frequency (from start to 60Hz)

	Set to 60Hz	Start	Stop	
Key	<div style="display: flex; justify-content: space-around;"> <div style="border: 1px solid black; padding: 2px 5px;">PU OP</div> <div style="border: 1px solid black; padding: 2px 5px;">6</div> <div style="border: 1px solid black; padding: 2px 5px;">0</div> </div>	<div style="border: 1px solid black; padding: 2px 5px;">WRITE</div>	<div style="display: flex; justify-content: space-around;"> <div style="border: 1px solid black; padding: 2px 5px;">FWD</div> or <div style="border: 1px solid black; padding: 2px 5px;">REV</div> </div>	<div style="border: 1px solid black; padding: 2px 5px;">STOP</div>
Indication	<div style="display: flex; align-items: center;"> <div style="border: 1px solid black; padding: 2px 5px; margin-right: 5px;">60</div> <div style="margin-left: 5px;"> • Hz A V </div> </div>	<div style="display: flex; align-items: center;"> <div style="border: 1px solid black; padding: 2px 5px; margin-right: 5px;">60.00</div> <div style="margin-left: 5px;"> • Hz A V : Alternate F </div> </div>	<div style="display: flex; align-items: center;"> <div style="border: 1px solid black; padding: 2px 5px; margin-right: 5px;">60.00</div> <div style="margin-left: 5px;"> • Hz A V </div> </div>	<div style="display: flex; align-items: center;"> <div style="border: 1px solid black; padding: 2px 5px; margin-right: 5px;">000</div> <div style="margin-left: 5px;"> Hz A V </div> </div>

○ Example where speed is changed during operation (from 60Hz to 30Hz)







	(Set to 60Hz)		Set to 30Hz
Key	—	<div style="border: 1px solid black; padding: 2px 5px;">PU OP</div>	<div style="display: flex; justify-content: space-around;"> <div style="border: 1px solid black; padding: 2px 5px;">3</div> <div style="border: 1px solid black; padding: 2px 5px;">0</div> </div> <div style="border: 1px solid black; padding: 2px 5px; margin-top: 5px;">WRITE</div>
Indication	<div style="display: flex; align-items: center;"> <div style="border: 1px solid black; padding: 2px 5px; margin-right: 5px;">60.00</div> <div style="margin-left: 5px;"> • Hz A V </div> </div>	<div style="display: flex; align-items: center;"> <div style="border: 1px solid black; padding: 2px 5px; margin-right: 5px;">60.00</div> </div>	<div style="display: flex; align-items: center;"> <div style="border: 1px solid black; padding: 2px 5px; margin-right: 5px;">30</div> <div style="margin-left: 5px;"> • Hz A V : Alternate F </div> </div>

Pressing **PU** clears alternating display and sets to selected frequency.

Note: Direct setting of output frequency is impossible while the MONITOR mode indicator lamp is on.



To set output frequency, press  key to break MONITOR mode.

●JOG operation

	JOG mode selection	Operation*
Key	 	 (or )
Indicator	 ○ Hz ○ A ○ V ○ ○ ○ *	*  * Hz ○ A ○ V * ○ ○ *

*If the motor does not start, check the starting frequency. (FUNCTION 13)

You cannot jog at 5 Hz, if "Min. Frequency" is set higher than 5 Hz. (FUNCTION 2)
Reset 13 and 2.

- NOTES: 1. JOG mode cannot be selected while the motor is in operation. press  key to stop the motor and then select JOG mode.
2. To break JOG mode operation, press  key.
3. Desired frequency and acceleration/deceleration time fo JOG mode operation can be set by specifying the corresponding function (control variable) . (FUNCTION 15 and 16)

When the inverter is shipped, the JOG frequency and acceleration/deceleration time are set to 5 Hz and 0.5sec., respectively (it takes 0.04sec. for increaze of frequency up to 5 Hz) .

4.4 Caution for operation

1.	Selection of operation mode	<p>Operation mode cannot be changed during operation of the inverter.</p> <p>Note that an operation mode indicator lamp flickers during operation of the inverter.</p> <p>When external start signal is on, operation mode cannot be changed from "PU operation" to "external signal operation" (turn off the signal before changing operation mode).</p>
2.	Setting of speed during speed RPM setting	<p>(1) While speed being displayed in RPM (see P. 90), desired speed should be specified in terms of RPM.</p> <p>(2) Speed should not be specified by operating <input type="checkbox"/> and <input type="checkbox"/> keys (step speed setting).</p>
3.	Digits of numerical value and decimal point	<p>(1) To specify numerical value, maximum 4-digit numerals can be entered (if a numerical value of more than 4 digits is entered, the first digit is ignored).</p> <p>Ex.: 12345 "2345" is entered.</p> <p>(2) When "0.**" (* is for any numeral) must be entered, "0" should not be omitted. If ".**" is entered, it is read as "**".</p>
4.	Range of setting	<p>(1) Direct setting (reference frequency is set by operating ten keys)</p> <p>If a value above the pre-set frequency is entered in direct setting, an error occurs.</p> <p>In this case, press <input type="checkbox"/> key and enter correct value below pre-set value.</p> <p>Range of setting ... From the minimum frequency limit to the maximum frequency limit (When the product is shipped, the maximum and minimum frequency limits are set to 0 Hz and 120Hz respectively.)</p>

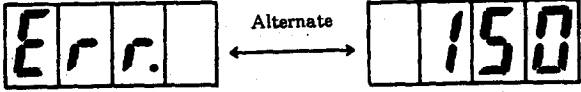
<p>4.</p>	<p>Ex.: If "150Hz" is entered, error is displayed as shown below.</p> <div style="text-align: center;">  </div> <p>This is because the maximum frequency (FUNCTION 1) is already pre-set to 120Hz.</p> <p>(2) Step setting (▲ and/or ▼ key is pressed to specify reference frequency)</p> <p>Reference frequency can be set within the specified range (from maximum frequency limit to minimum frequency limit) .</p> <p>If key is held down while frequency is at the maximum or minimum limit value, the frequency remains unchanged.</p>
<p>5. Conditions under which reference frequency (or speed) is unacceptable (PU operation mode)</p>	<p>(1) " External signal operation " mode is selected.</p> <p>(2) MONITOR mode is selected (step setting is possible during MONITOR mode) .</p> <p>(3) Reference frequency (speed) is out of the specified range. (Above or below pre-set max and min frequency.) (FUNCTION . 1 and 2)</p>

§ 5. SETTING OF CONTROL VARIABLES (PARAMETERS)

The inverter has various control functions. To assure the best performance from your inverter and motor, these functions should be used with care and thought for application to the driven machine.

These functions can be set, and setting can be checked or changed by operating the PU.

5.1 Control functions and setting method

1	"READ" and "WRITE" of function See P.94														
<table border="1" style="width: 100%; border-collapse: collapse;"> <thead> <tr> <th colspan="2" style="text-align: center;">Function</th> <th style="text-align: center;">Check (read)</th> <th style="text-align: center;">Change (write)</th> </tr> </thead> <tbody> <tr> <td style="text-align: center;">1st functions</td> <td>Basic control functions</td> <td style="text-align: center;">[SET] · [FUNC.] · [READ]</td> <td rowspan="3" style="vertical-align: top; padding: 5px;"> Setting should be changed after check. [SET VALUE] · [WRITE] </td> </tr> <tr> <td style="text-align: center;">2nd functions</td> <td>Secondary functions (operating conditions, etc.)</td> <td style="text-align: center;">[SET] · [2nd] · [FUNC.NO.] · [READ]</td> </tr> <tr> <td style="text-align: center;">3rd functions</td> <td>Auxiliary functions (calibration, etc.)</td> <td style="text-align: center;">[PU OP] · [2nd] · [0] · [1] · ([SHIFT]) · [READ]</td> </tr> </tbody> </table>		Function		Check (read)	Change (write)	1st functions	Basic control functions	[SET] · [FUNC.] · [READ]	Setting should be changed after check. [SET VALUE] · [WRITE]	2nd functions	Secondary functions (operating conditions, etc.)	[SET] · [2nd] · [FUNC.NO.] · [READ]	3rd functions	Auxiliary functions (calibration, etc.)	[PU OP] · [2nd] · [0] · [1] · ([SHIFT]) · [READ]
Function		Check (read)	Change (write)												
1st functions	Basic control functions	[SET] · [FUNC.] · [READ]	Setting should be changed after check. [SET VALUE] · [WRITE]												
2nd functions	Secondary functions (operating conditions, etc.)	[SET] · [2nd] · [FUNC.NO.] · [READ]													
3rd functions	Auxiliary functions (calibration, etc.)	[PU OP] · [2nd] · [0] · [1] · ([SHIFT]) · [READ]													
2	<p>"ALL CLEAR" By performing the following operation, user's settings are reset to the initial settings (i.e., setting made at shipment of inverter).</p>														
<p style="text-align: center;">[PU OP] · [SET] · [2nd] · [8] · [●] · [9] · [●] · [WRITE]</p> <p>After [WRITE] is pressed, ALLC appears and flickers.</p>															
3	Prohibition of parameter WRITE														
<p style="text-align: center;">[PU OP] · [SET] · [2nd] · [7 ACCEL] · [7 DECEL] · [1 MAX] · [WRITE]</p>															

(1) Set the frequency for meter full-scale reading**.

(2) Press **FWD** or **REV** key to start the motor.

PU
OP **6** **0** **WRITE**

When output frequency at 5 V of frequency reference voltage is 60Hz.

(3) Press the following keys to select CALIBRATION mode.

PU
OP **2nd** **0** **1**

(4) While observing the pointer of frequency meter, press **▲** or **▼** key reading will increase or decrease.

(5) When the meter has been calibrated, press **WRITE** key.

(6) Press **STOP** Key to stop the motor.

** : For full-scale reading, "output frequency at 5 V of frequency reference voltage" is specified.

Note: When "prohibition of parameter WRITE" has been set, frequency meter cannot be calibrated.

IMPORTANT NOTE

This frequency inverter allows you access to multiple control variables which must be used with care. It has been fully tested to perform to its own control parameters. But this may not be the case of the electric motor to which it is to be applied.

If you require to increase the speed of any electric motor over its rated nameplate speed, then you must check with the motor manufacturer first, that the motor will operate safely and satisfactorily and that you are not exceeding any electrical or mechanical design parameters of the motor.

If in doubt ——— ASK.

5.2 Examples of operation

(1) Setting of 1st function (acceleration/deceleration time)

	1st function	Setting of acceleration time	Read present value	Change to 10sec.	Write
Key	SET	7 ACCEL	READ	1 . 0	WRITE
Display	Pr <input type="checkbox"/> <input checked="" type="checkbox"/> <input type="checkbox"/> <input checked="" type="checkbox"/> Hz A V	Pr 7	5.0 (5 sec.) Initial setting	10 (10sec.)	10 ↑ Alternate. Pr 7

Note: When another 1st function must be set after the 1st function has been set, the new desired function can be called by just pressing the corresponding function key (that is, SET key is not required to be pressed).

(2) Setting of 2nd function (frequency reference for JOG operation)

	Selection of 2nd function	Setting of frequency for JOG operation	Read present value	Change to 10Hz	Write
Key	SET · 2nd	1 . 5	READ	1 . 0	WRITE
Display	Pr. <input type="checkbox"/> <input checked="" type="checkbox"/> <input type="checkbox"/> <input checked="" type="checkbox"/> Hz A V	Pr. 15	5.00 (5 Hz) Initial setting	10 (10Hz)	10.00 ↑ Alternate. Pr. 15

Note: 1. A dot is placed after Pr when the 2nd function is selected, like Pr.

2. When another 2nd function has to be set immediately after a 2nd function has already been set, the new desired function can be called by pressing 2nd key, and specifying the function No. (SET key is not required to be pressed).

(3) Setting of 3rd function (examples of bias and gain settings for frequency reference voltage signal).

Selection of 3rd function																
Key	<table border="1"> <tr> <td>PU</td> <td>2nd</td> <td>0</td> <td>1</td> </tr> <tr> <td>OP</td> <td></td> <td></td> <td></td> </tr> </table>	PU	2nd	0	1	OP										
PU	2nd	0	1													
OP																
Display	<table border="1"> <tr> <td>[]</td> <td>[]</td> <td>[]</td> <td>[]</td> <td>○ Hz</td> </tr> <tr> <td>[]</td> <td>[]</td> <td>[]</td> <td>[]</td> <td>○ A</td> </tr> <tr> <td>[]</td> <td>[]</td> <td>[]</td> <td>[]</td> <td>○ V</td> </tr> </table>	[]	[]	[]	[]	○ Hz	[]	[]	[]	[]	○ A	[]	[]	[]	[]	○ V
[]	[]	[]	[]	○ Hz												
[]	[]	[]	[]	○ A												
[]	[]	[]	[]	○ V												

Bias	Read	set to 10Hz	Write
SHIFT	READ	1 . 0	WRITE
[] - [] 2	[] [] [] 0 (0 Hz)	[] [] 1 0 (10Hz)	[] [] 1 0 ↑ Alternate. [] - [] 2

Note: Do not input frequency reference signal across terminals 2 and 5.

Gain	Read	Set to 120Hz	Write
SHIFT · SHIFT	READ	1 . 2 . 0	WRITE
[] - [] 3	6 0 0 0 0	[] [] 1 2 0 (120Hz)	[] [] 2 0 ↑ Alternate [] - [] 3

Note: Do not input frequency reference signal or used 5V input signal.

Note: For calibration of frequency meter, see P.84.

5.3 Caution

1	READ function	<p>READ is possible in "external signal operation" mode as well as "PU operation" mode.</p> <p>It is also possible even during operation of motor.</p>
2	WRITE function	<p>WRITE is possible <u>only</u> in "PU operation" mode.</p> <p>It is impossible during operation of motor (setting of function No.10 (PWM mode), however, can be changed during operation of motor).</p>
3	Selection of 3rd function	<p>READ and WRITE of 3rd function are possible only in "PU operation" mode.</p>
4	<p><u>ERROR (Err.)</u> display</p>	<p>Error appears when,</p> <ul style="list-style-type: none"> (1) WRITE is tried during operation of motor, or (2) entered value is out of the specified range, or (3) illegal function No. is set, or (4) WRITE is tried during "external signal operation" mode, or (5) WRITE is tried while parameter WRITE has been prohibited (see § 5. and § 9.).
5	Clear of ERROR display	<p>Error condition can be cleared as follows:</p> <ul style="list-style-type: none"> (1) Press CLEAR key. (2) If error is caused by setting illegal function No. (see § 9.), press SET key.

§ 6. MONITOR





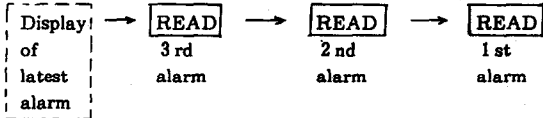

Output frequency, output voltage (including that during acceleration and deceleration), motor current, direction of rotation of motor, and alarm condition can be monitored by performing operations described below.

MONITOR is possible after MONITOR key is pressed.

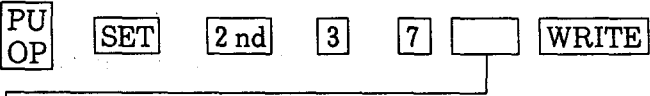
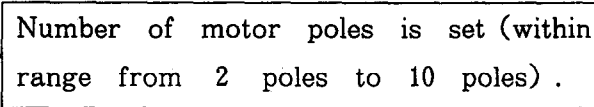
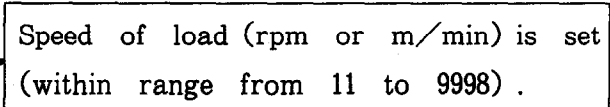
Operation		Display example
Output frequency	<p>Inverter output frequency can be read by pressing MONITOR key.</p> <p>Note: If PU OP key is pressed during monitoring, MONITOR mode is cancelled and the preset output frequency is displayed.</p>	<div style="display: flex; align-items: center; justify-content: center;"> <div style="border: 1px solid black; padding: 2px; margin-right: 10px;">60.00</div> <div style="display: flex; flex-direction: column; gap: 5px;"> ✕ Hz ○ A ○ V </div> </div> <div style="display: flex; align-items: center; justify-content: center; margin-top: 10px;"> ✕ ○ ○ ○ </div>
Motor current	<p>Motor current can be read by pressing SHIFT key.</p> <p>Note: Motor current during acceleration or deceleration can be also displayed. Displayed current, however, will not change if acceleration or deceleration is momentary.</p>	<div style="display: flex; align-items: center; justify-content: center;"> <div style="border: 1px solid black; padding: 2px; margin-right: 10px;">6.5</div> <div style="display: flex; flex-direction: column; gap: 5px;"> ○ Hz ✕ A ○ V </div> </div> <div style="display: flex; align-items: center; justify-content: center; margin-top: 10px;"> ✕ ○ ○ ○ </div>
Output voltage	<p>Inverter output voltage can be displayed by pressing SHIFT key twice successively.</p>	<div style="display: flex; align-items: center; justify-content: center;"> <div style="border: 1px solid black; padding: 2px; margin-right: 10px;">22.00</div> <div style="display: flex; flex-direction: column; gap: 5px;"> ○ Hz ○ A ✕ V </div> </div> <div style="display: flex; align-items: center; justify-content: center; margin-top: 10px;"> ✕ ○ ○ ○ </div>
	<p>Alarm code can be read by pressing SHIFT three times successively.</p>	

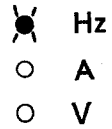
Operation	Display example
<p>Notes: 1. The function is capable of storing a maximum of four alarm codes. Stored alarm codes can be read one after another (see § 7 for alarm codes).</p> <p>How to read alarm codes</p>  <p>○ When READ key is pressed, the latest alarm code appears again.</p> <p>○ When SHIFT key is pressed, the output frequency at that time is displayed.</p> <p>2. Stored alarm codes are held even after the inverter is turned off.</p>	<p style="text-align: right;">○ Hz ○ A ○ V</p> <p style="text-align: center;">E I P F</p> <p style="text-align: center;">× ○ ○ ○</p> <p>(1) For the latest alarm, a dot is placed by after E (see an example shown above).</p> <p>(2) If no alarm has been stored, the display is as shown below.</p> <p style="text-align: center;">E . 0</p>

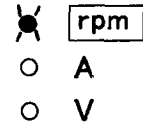
Alarm condition

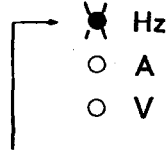
Operation	Display example
<p>Speed RPM is displayed, instead of inverter output frequency, when the following setting has been accomplished.</p> <p>  </p> <p>  </p> <p>Speed RPM which corresponds to inverter output frequency is displayed.</p> <p> Dis- played speed $N = \frac{120 \times f \text{ (Frequency)}}{P \text{ (Number of poles)}}$ </p> <p>Note: Displayed speed RPM is in proportion to output frequency.</p> <p>  </p> <p>Speed at 60Hz of inverter output frequency is set.</p> <p>During "PU operation" or "external signal operation" mode, direction of rotation of the motor can be checked through the MONITOR indicator lamp. FORWARD... "Hz" (or "A") lamp lights. REVERSE... "Hz" (or "A") lamp flickers.</p>	<p>● When "4" is set for number of motor poles ... (In this example, inverter output frequency is assured to be set at 30Hz previously.)</p> <p>   </p> <p>● Unit used in display</p> <p>When speed is monitored in terms of rpm or m/min, the label which indicates the unit (rpm or m/min) should be applied to the monitor display unit over legend "Hz"</p> <p>   </p> <p>   </p> <p>This lamp flickers when the motor rotates in reverse direction.</p>

Speed (rpm, m/min) display

Operation		Display example
Operation status	<p>Status of inverter during operation can be monitored through the OPERATION MODE indicator lamps (lamps just above EXT OP and PU OP keys) .</p> <p>The lamp which corresponds to the selected mode flickers during operation of motor.</p>	<div style="display: flex; align-items: center;"> <div style="margin-right: 20px;"> </div> <div style="margin-right: 20px;"> <p>○ Hz</p> <p>○ A</p> <p>○ V</p> </div> </div> <div style="margin-top: 10px;"> </div> <p>During operation, either one of these lamps flickers.</p>

§ 7. DISPLAY

7.1 Alarm display

If failure occurs during operation of the inverter, an alarm code is displayed automatically.











Alarm code		Description
Display	Code	
E0C1	EOC1	Inverter output current exceeded the overcurrent limit during acceleration.
E0C2	EOC2	Inverter output current exceeded the overcurrent limit during constant-speed operation.
E0C3	EOC3	Inverter output current exceeded the overcurrent limit during deceleration.
E0VF	EOVT	Braking regenerative power from motor exceeded the regenerative overvoltage limit.
E1HN	ETHM	Electronic thermal relay in the inverter was activated (current is below 150% of preset current).
E1HT	ETHT	Electronic thermal relay in the inverter was activated (current is over 150% of preset current).
E1PF	EIPF	Instantaneous power failure protective function was activated.
E1n	EFIN	Temperature of transistor heatsink exceeded the specified limit.
E bE	E BE	Brake transistor fault detection.
E0LT	EOLT	Stall preventive function was activated during constant-speed operation and stopped the motor.
E PE	E PE	Memory in the inverter is corrupted.
EUVF	EUVT	Inverter input voltage fell below the specified limit.
E GF	E GF	Overcurrent due to earth fault on the inverter output side.
E0HT	EOHT	Externally installed thermal relay activated (overheat).
E0PT	EOPT	Built-in optional unit connection failure during operation.











7.2 Indicator lamps in MONITOR mode









Indication	Description	
○ Hz	Frequency is displayed.	If stall preventive function is activated during MONITOR mode, all MODE lamps, other than that selected flicker.
○ A	Motor current is displayed.	
○ V	Output voltage is displayed.	

7.3 Characters appearing in readout

The alphanumeric characters which appear in the readout are as listed below.

Letter	Display
0	
1	
2	
3	
4	
5	
6	
7	
8	
9	

Letter	Display
A	
B	
C	
E	
F	
G	
H	
I	
J	
L	

Letter	Display
M	
N	
O	
P	
T	
U	
V	
r	
-	

§ 8. LIST OF FUNCTIONS

Function No. (parameter)	Function	Setting range	Initial setting	Refer to	
1 st function	0	Torque boost (manual)	0 - 30%	See P.101	P.101
	1	Max. frequency limit	0 - 120Hz	120Hz	P.98
	2	Min. frequency limit	0 - 60Hz	0 Hz	P.98
	3	V/F (base frequency)	50 - 360Hz	50Hz	P.102
	4	Multi-speed setting: 1st (high speed)	0 - 360Hz	60Hz	P.103
	5	Multi-speed setting: 2nd (middle speed)	0 - 360Hz	30Hz	P.103
	6	Multi-speed setting: 3rd (low speed)	0 - 360Hz	10Hz	P.103
	7	Acceleration time	0.1 - 3600sec	See P.99	P.99
	8	Deceleration time	0.1 - 3600sec	See P.99	P.99
	9	Electronic thermal relay (overheat)	0 - 999.9A	See P.99	P.99
2 nd function	10	PWM mode	0 - 15	3	P.104
	11	DC dynamic brake time	0 - 10sec	0.5sec	P.105
	12	DC dynamic brake voltage	0 - 20%	See P.105	P.105
	13	Starting frequency	0.5 - 10Hz	0.5Hz	P.106
	14	Load pattern selection	0 (constant torque) 1 (reduced torque)	0	P.102
	15	JOG frequency	0 - 360Hz	5 Hz	P.106
	16	JOG acceleration/ deceleration time	0.1 - 3600sec	0.5sec	P.106
	17	2nd acceleration/ deceleration time	0.1 - 3600sec	5 sec	P.100
	18	High-speed maximum frequency limit	120 - 360Hz	120Hz	P.99
	19	Base frequency voltage	0 - 500V, 9999	9999	P.102
	20	Frequency at 5 V input voltage	1 - 360Hz	60Hz	P.98
	21	Stall prevention level	0 - 200%	150%	P.107
	22	2nd stall prevention level (current)	0 - 200%	150%	P.108
	23	2nd stall prevention level (frequency)	0 - 360Hz	0 Hz	P.108
	24	Multi-speed setting: 4 th	0 - 360Hz, 9999	9999	P.103

Function (parameter)	Function	Setting range	Initial setting	Refer to	
2nd function	25	Multi-speed setting: 5 th	0 - 360Hz, 9999	9999	P.103
	26	Multi-speed setting: 6 th	0 - 360Hz, 9999	9999	P.103
	27	Multi-speed setting: 7 th	0 - 360Hz, 9999	9999	P.103
	28	Multi-speed input correction	0, 1	0	P.103
	29	Acceleration/deceleration pattern selection	0, 1, 2	0	P.100
	30	Regenerative brake duty	0 - 30%	See P.101	P.107
	31	Frequency jump 1 A	0 - 360Hz, 9999	9999	P.107
	32	Frequency jump 1 B	0 - 360Hz, 9999	9999	P.107
	33	Frequency jump 2 A	0 - 360Hz, 9999	9999	P.107
	34	Frequency jump 2 B	0 - 360Hz, 9999	9999	P.107
	35	Frequency jump 3 A	0 - 360Hz, 9999	9999	P.107
	36	Frequency jump 3 B	0 - 360Hz, 9999	9999	P.107
	37	Speed display	See P.104-105	0	P.104
	38	FM terminal output basic frequency	1 - 360Hz	60Hz	P.110
	39	Frequency at 20mA input	1 - 360Hz	60Hz	P.98
	40	Torque boost (automatic)	0 - 200%	0	P.101
	41	Reverse operation	0, 1	0	P.108
	42	Up-to-frequency sensitivity	1 - 100%	10%	P.109
	43	Output frequency detection	0.5 - 360Hz, 9999	6 Hz	P.109
	44	Output frequency detection during reverse operation	0.5 - 360Hz, 9999	9999	P.110
45	DC dynamic brake frequency	0 - 60Hz	3 Hz	P.105	
46	External thermal relay signal input	0, 1, 100, 101	0	P.109	
77	Parameter WRITE prohibition	0, 1	0	P.97	

Function No. (parameter)	Function	Setting range	Initial setting	Refer to	
78	Reversing prevention	0, 1	0	P.97	
79	Operation mode selection	0, 1, 2	0	P.97	
3rd function	C-1	Frequency meter calibration	0 - 360Hz	60Hz	P.111
	C-2	Bias for frequency reference voltage signal	0 - 120Hz	0 Hz	P.111
	C-3	Gain for frequency reference voltage signal	1 - 360Hz	60Hz	P.111
	C-4	Bias for frequency reference current signal	0 - 120Hz	0 Hz	P.111
	C-5	Gain for frequency reference current signal	1 - 360Hz*	60Hz	P.111

Least setting increments:

Frequency 0.01Hz

Time 0.1sec.

Current 0.1A

% 1%

Voltage 1V

Note * : When a parameter unit of old specification (Spec. No. BKO-C2128) is used, the least setting increment of gain for frequency reference current signal is 1 Hz.

§ 9. DETAILS OF EACH FUNCTION

OPERATION MODE SELECTION, PARAMETER WRITE PROHIBITION AND REVERSING PREVENTION

Parameter WRITE prohibition 7 7

WRITE parameter can be prohibited.

Setting	Description
" 0 "	WRITE parameter is possible. (Initial setting)
" 1 "	WRITE parameter is impossible. (Note)

Note: Function (parameter) No. 77 and 79 can still be written.

Reversing prevention 7 8

Reversing of motor operation can be prevented.

Setting	Description
" 0 "	Motor operation can be reversed. (initial setting)
" 1 "	Motor operation cannot be reversed. (Note)

Note: Reversing is impossible in "PU operation" mode as well as in "external signal operation" mode.

Operation mode selection 7 9

Operation mode can be fixed to either "PU operation" or "external signal operation", or both.

Setting	Description
" 0 "	Switching between "PU operation" and "external signal operation" is possible. (Initial setting)
" 1 "	Only "PU operation" is possible.
" 2 "	Only "external signal operation" is possible.

Note: Function (parameter) No. 79 can be changed even in "external signal operation" mode.

MAXIMUM OUTPUT FREQUENCY SETTING

Frequency with reference voltage signal at 5 V

Frequency with reference current signal at 20mA

Output frequency at DC 5V (or DC 10V) or 20mA of frequency reference signal can be set. That is, the maximum output frequency in "external signal operation" mode is set.

Acceleration/deceleration time is the time taken for acceleration or deceleration up to the maximum frequency.

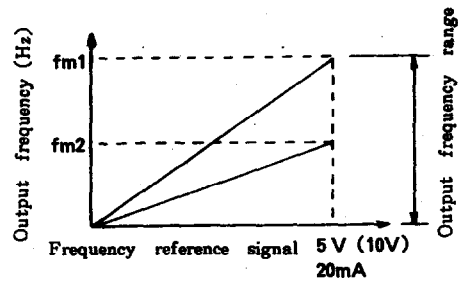

Note: The set maximum frequency changes automatically when setting of "gain for frequency reference voltage signal" or "frequency reference current signal, gain" (see P.86) is changed. Since this function has the priority level same as that of 3rd function (C-3 and C-5), priority is given to the latest set function, when this function is set together with a 3rd function.

MAXIMUM/MINIMUM FREQUENCY LIMIT

Maximum frequency limit

Minimum frequency limit

Output frequency can be clamped to desired maximum and/or minimum frequency.

Note: When minimum limit frequency is set, it should be higher than the starting frequency (see "Starting frequency setting", P.106). Maximum limit frequency may not be higher than 120Hz.

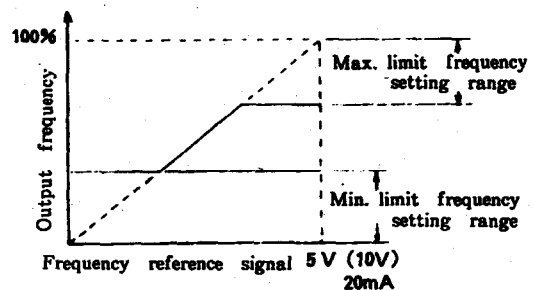

High-speed maximum frequency limit 1 8

Maximum limit frequency can be set to a frequency higher than 120Hz for exceptionally high-speed operation.

The maximum frequency limit set by the 1st function is overridden by this setting.

ELECTRONIC THERMAL RELAY SETTING

Electronic thermal relay 9

To protect the motor from overheating, motor rated current value can be set directly in amperage.

When the inverter is shipped, it is set to the rated output current of inverter. For FR-Z220-0.4K and 0.75K, however, it is set to 85% (Amp.) of the rated output current of inverter.

FR-Z220-0.4K 2.6A

FR-Z220-0.75K 4.3A

For models larger than FR-Z220-1.5K, the factory setting is the rated output current in accordance with the standard specification (see P. 61).

ACCELERATION/DECELERATION TIME SETTING

Acceleration time 7 Deceleration time 8

Acceleration/deceleration time can be set within the range from 0.1 sec. to 3,600 sec. Acceleration time is the time taken for acceleration to output frequency (f_m) set by function No. 20 (frequency at 5 V input voltage) (same for acceleration time in JOG operation, and for 2nd acceleration/deceleration time).

Initial setting for models smaller than -7.5K 5 sec.

Initial setting for models larger than -11K 15 sec.

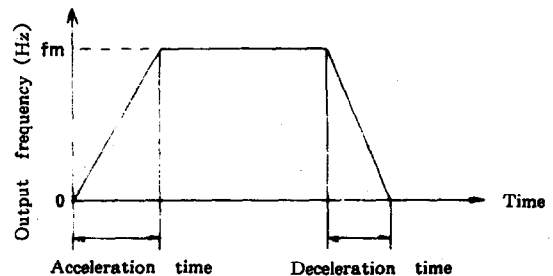

Note: In the case of S-pattern acceleration/deceleration "A", acceleration time is the time taken for acceleration up to the basic frequency.

2nd acceleration/deceleration time 1 7

2nd acceleration/deceleration time can be selected with external contact signal (it is selected when terminal RT is connected to SD).

Initial setting: 5 sec.

Example in "PU operation" mode

When the inverter is operated at 120Hz of output frequency with "frequency at 5V input voltage" set at 60Hz, and acceleration time set at 3 sec., the acceleration time is 6 sec.

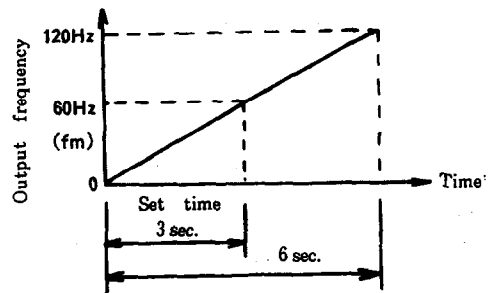

ACCELERATION/DECELERATION PATTERN SELECTION

Acceleration/deceleration pattern selection 2 9

Setting "0" (Linear acceleration/deceleration)

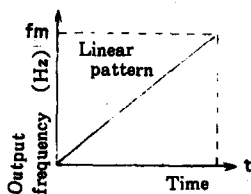

Frequency (speed) increases linearly up to the frequency (fm) set for 5V frequency reference voltage signal.

Setting "1" (S-pattern acceleration/deceleration "A")

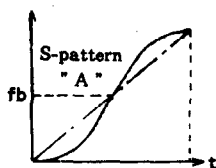

Acceleration is faster when motor output torque is larger, and slower when motor output torque is smaller. Acceleration/deceleration time can be shortened when this pattern is selected.

Setting " 2 " (S-pattern acceleration/deceleration " B ")

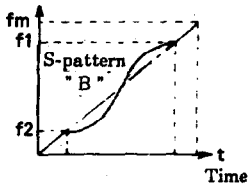

Acceleration/deceleration pattern is S-shaped within the frequency range between "f1" and "f2" (basically same time as that of linear acceleration/deceleration) in this frequency range).

Smooth acceleration and deceleration can be assured.

MOTOR TORQUE ADJUSTING (TORQUE BOOST)

Torque boost (manual) 0

Motor torque in the low-frequency range can be adjusted to motor load.

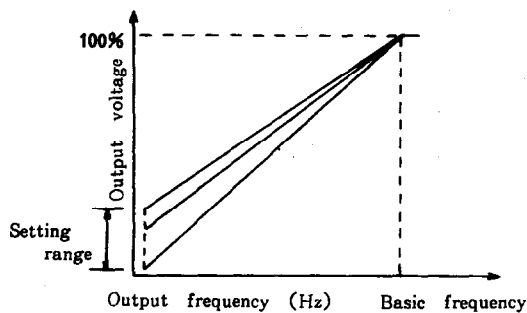

Initial setting:

For models smaller than 7.5K 6 %

For models larger than 11K 3 %

Torque boost (automatic) 4 0

Load current is measured and inverter output voltage (motor torque) is automatically adjusted to match load current.

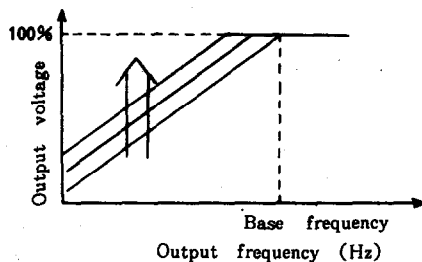

Notes: 1. Function No. 0 and No. 40 can be used at the same time.

2. If setting is excessively large, overcurrent trip may occur. It is recommended to set while observing motor current (use MONITOR function).

VOLTAGE/FREQUENCY (V/F) CHARACTERISTIC SETTING

V/F (base frequency) 3

Base frequency voltage 1 9

Base frequency (frequency at the rated motor torque) can be set in accordance with the motor rating within the range from 50Hz to 360Hz.

In the case of Z200 series, output voltage at the base frequency can be also set. When set putout voltage is below the power supply voltage, the maximum output reference of inverter is equal to output voltage set by user.

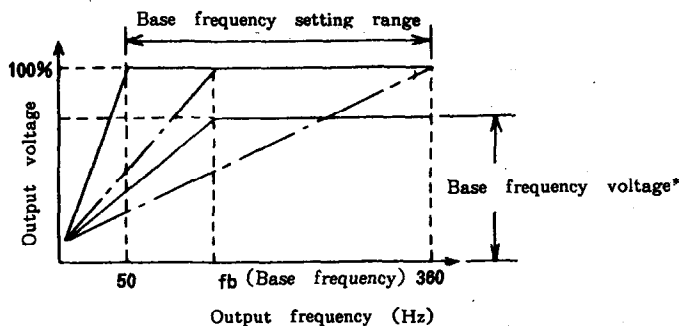

* If it is set to "9999" (initial setting), the maximum output voltage is equal to the power supply voltage.

LOAD PATTERN SELECTION

Load pattern selection 1 4

V/F characteristic which match load characteristic can be selected.

Setting " 0 " (initial setting)

Setting " 1 "

For constant-torque load
(conveyor, carriage, etc.)

For reduced torque load
(fan, pump, etc.)

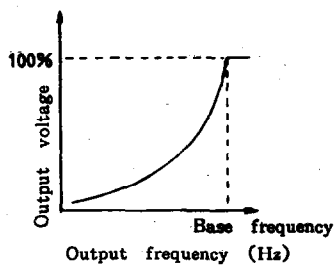
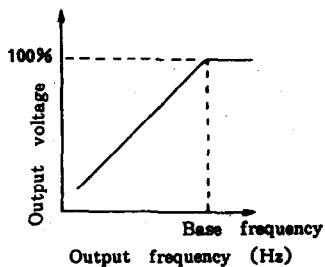

Desired V/F characteristic can be obtained by co-ordinating this setting with " torque boost ", " V/F " and " base frequency voltage " settings.

MULTI-SPEED SETTING

1st speed (high speed) <u>4</u>	3-speed setting (1st function)
2nd speed (middle speed) <u>5</u>	
3rd speed (low speed) <u>6</u>	
4th speed <u>2</u> <u>4</u>	Multi-speed setting (2nd function)
5th speed <u>2</u> <u>5</u>	
6th speed <u>2</u> <u>6</u>	
7th speed <u>2</u> <u>7</u>	

Only by switching external contact signals, desired speed range can be selected (SD is connected to RH, RM or RL).

Each speed (frequency) can be set within the range from 0 Hz to 360 Hz.

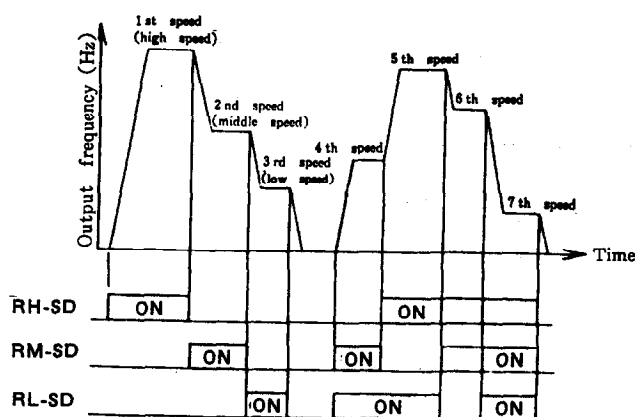

Notes: 1. When "9999" is set (initial setting) for 4th, 5th, 6th or 7th speed, these speeds are not operational.

2. If two speeds are selected from 1st, 2nd and 3rd speeds at the same time, the lower speed (frequency) is selected. (By default)

Ex.: When "40Hz" and "50Hz" are selected for high speed (RH) and low speed (RL) respectively and RH-SD and RL-SD are closed at the same time, then the output frequency (speed) is 50Hz.

Multi-speed input correction 2 8

When multi-speed operation is done as described above, "speed correction signal" can be input from external signal source to correct speed (frequency).

Setting	Correction
" 0 "	Speed (frequency) is not corrected (initial setting) .
" 1 "	Speed (frequency) is corrected.

Note: The signal should be input through terminal " 1K " or " 1E " .

PWM MODE

PWM mode 1 0

By changing carrier frequency (hertz) , motor sound and vibration can be reduced.
80Hz per graduation change.

One of 16 carrier frequencies can be selected.

Note: Initial setting is " 3 " .

SPEED DISPLAY

Speed display 3 7

Motor speed can be directly displayed in MONITOR mode in terms of rpm or m/min, instead of inverter output frequency.

Displayed motor speed is that converted from inverter output frequency, and not always equal to true speed.

Setting " 0 "	Inverter output frequency (Hz) is displayed (initial setting) .
Setting " 2 " - " 10 " (Number of motor poles is input.)	Motor speed is displayed in rpm. (Note 1)
Setting " 11 " - " 9998 "	Speed of load is displayed. (Note 2)

Ex.: 1. Display of motor speed (rpm)

When 4 - pole motor is driven by the inverter.

Setting → 4

Notes: 1. Setting should be an even number (motor poles) within the range

from 2 to 10.

If an odd number is input, error occurs.

2. Set speed at 60Hz of output frequency.

The displayed speed may differ from true speed, due to slip of the motor.

When motor or load speed is displayed in rpm or m/min, all other functions related to speed should be also set in rpm or m/min (except for 3rd functions, other than "frequency meter calibration" function).

In this case, fractions are disregarded.

3. When speed is set in "PU operation" mode, do not use and keys.

2. Display of linear speed

When 55m/min must be set for 60Hz of output frequency,

Note: Be sure to set the linear speed at 60Hz output frequency. Value out of range from 11 to 9998 cannot be input.

If "10" is input, for example, speed is displayed for 10-pole motor.

DC DYNAMIC BRAKE TIME SETTING

DC dynamic brake time

DC dynamic brake voltage

DC dynamic brake frequency

Accuracy in stop position can be adjusted by setting the DC dynamic brake torque (voltage), braking time (time taken for braking), and brake starting frequency (*).

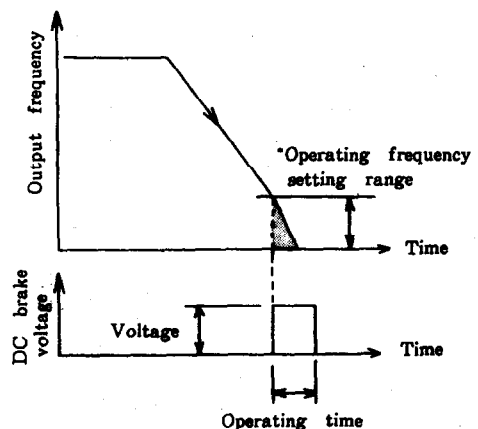

Notes: 1. When DC dynamic brake is not required, set brake time to "0".

2. If speed is decelerated by decreasing frequency reference signal voltage (or current, or by pressing \blacktriangledown key), the DC dynamic brake starts operating at 0.5Hz of output frequency (initial setting).

3. Initial setting of DC dynamic brake voltage:

For models less than 7.5K 8%

For models larger than 11K 4%

STARTING FREQUENCY SETTING

Starting frequency $\boxed{1}$ $\boxed{3}$

Frequency for start of motor operation can be set within the range from 0.5Hz to 10Hz.

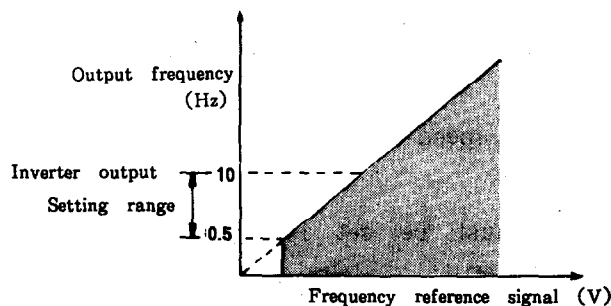

SETTING FOR JOG OPERATION

JOG frequency $\boxed{1}$ $\boxed{5}$

JOG accel./decel. time $\boxed{1}$ $\boxed{6}$

JOG operation can be realized by selecting JOG mode (JOG-SD is closed), and giving start signal and stop signal (STF and STR).

It is also possible to use the parameter unit for JOG operation.

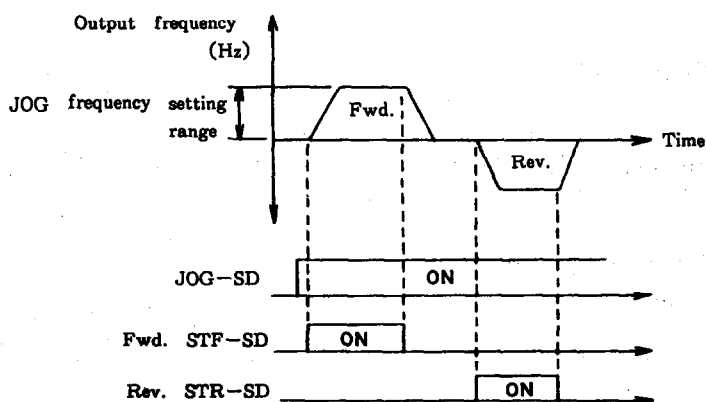

FREQUENCY JUMP SETTING

Frequency jump 3 1 to 3 6

A range of frequency, which causes resonance with vibration specific to the associated machine system, can be jumped over.

A maximum of three frequency ranges can be specified for frequency jump.

To specify jump frequency range, start frequency and end frequency range can be set.

When frequency reaches any one of the frequency jump ranges, frequency is clamped at point "1 A", "2 A" or "3 A" shown above.

Note: When "9999" (initial setting) is set, frequency jump control does not operate.

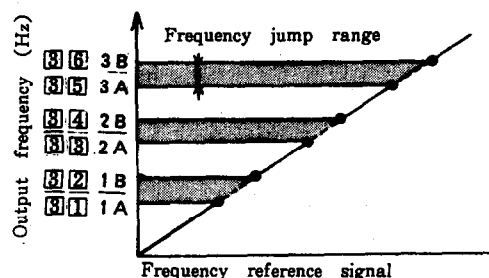

REGENERATIVE BRAKE DUTY (%ED) SETTING

Regenerative brake duty 3 0

Duty imposed on discharge resistor for regenerative braking can be set.

For exceptionally arduous duty, use of resistors having a larger capacity should be considered.

Initial setting: (1) 200V class

Models smaller than 3.7K ... 3%

Models 5.5K and 7.5K ... 2%

Models larger than 11K ... 0%

(2) 400V class

Models 2.2K to 7.5K 2%

Note: For models larger than 11K, setting is ignored.

STALL PREVENTION LEVEL SETTING

Stall prevention level 2 1

When a small-capacity motor (as compared with capacity of inverter) is driven by a large-capacity inverter, overload (excessively large torque) can be prevented by changing current level at which the stall preventive function is activated.

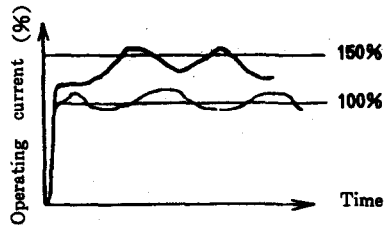

Note: Operating current (%) is a ratio of set current to the rated output current of the inverter.

When setting is zero, the stall preventive function is not activated.

2nd stall prevention level (current) 2 2

2nd stall prevention level (frequency) 2 3

Stall prevention level can be set in a specific range of currents or frequency.

When level must be below that specified by function No. 21 at frequency lower than 10Hz, 2nd stall prevention level is set.

REVERSE OPERATION using frequency reference signal

Reverse operation 4 1

Direction of rotation of motor can be reversed only by reversing polarity of frequency reference signal (analog signal).

For this purpose, auxiliary input terminals (1K or 1E) are used.

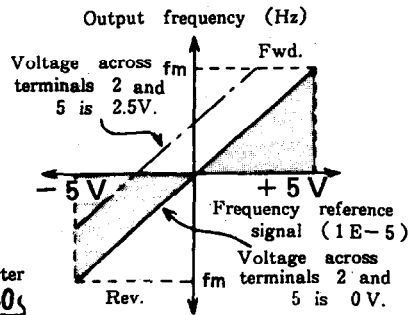
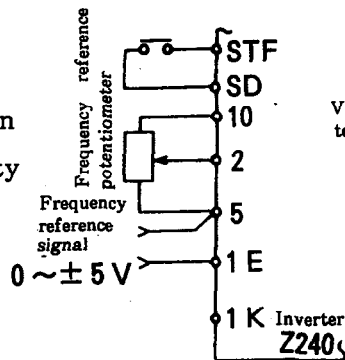

Setting	Reverse operation
" 0 "	Reverse operation is impossible (operation stops when minus signal is given).
" 1 "	Reverse operation is possible.

When start signal (STF, STR) is not changed and only frequency reference signal is used to reverse operation, auxiliary input terminals shown above are used.

When other frequency reference voltage signal is applied to terminals 2 and 4 at the same time, the voltage is added to the original reference voltage across terminals 1E (1K) and 5.

EXTERNAL THERMAL RELAY SIGNAL INPUT AND OUTPUT SHUTOFF MODE SELECTION

External thermal relay signal input and output shutoff mode 4 6

If an externally installed thermal relay is activated, the inverter output can be shut off and held shut off and the alarm signal can be output.

When the external thermal relay is reset automatically, the inverter does not resume operation automatically.

The thermal relay contact signal (normally closed) should be input through terminals JOG/OH-SD.

Inverter output can be shut off using terminal MRS, operating mode of which is shown below.

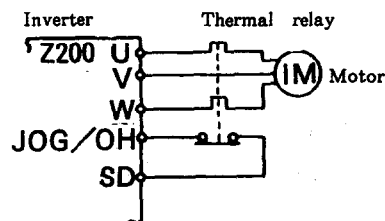

Setting	Function of terminal JOG/OH	Function of terminal MRS
" 0 "	JOG mode is selected. (initial setting)	Inverter output is shut off when terminals <u>MRS-SD</u> are closed.
" 1 "	External thermal relay is applicable.	same as above
"100"	JOG mode is selected.	Inverter output is shut off when terminals <u>MRS-SD</u> are open.
"101"	External thermal relay is applicable.	same as above

Note: If " 1 " or "101" is set while JOG/OH-SD is open, alarm "OHT" occurs.

OPEN COLLECTOR OUTPUT ADJUSTMENT AND SELECTION

Up-to-frequency sensitivity 4 2

(Terminal SU)

Frequency range within which "up-to-frequency" signal is output can be adjusted within the range from $\pm 1\%$ to $\pm 100\%$ of operating output frequency.

Output frequency detection 4 3

(Terminal FU)

Frequency to be detected can be set within the range from 0 Hz to 360Hz. If output frequency exceeds this point, "L" level signal is output from

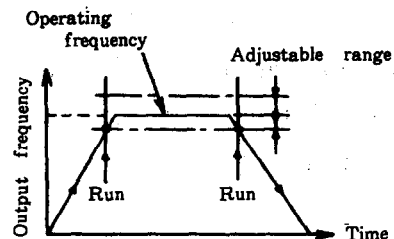

terminals FU and SE. Otherwise, "H" level signal is output.

This signal can be used to control a mechanical brake or other device. When it is set to "9999", the function is changed and a reference indicating that the inverter is in "PU operation" mode is output from terminal FU.

Output frequency detection during reverse operation [4] [4]

(Terminal FU)

For operation of a hoist or elevator, for example, operation timing of magnetic brake can be set differently between forward, run (up) and reverse, run (down).

The initial setting is "9999", where output frequency is detected at 6 Hz during forward run and reverse run.

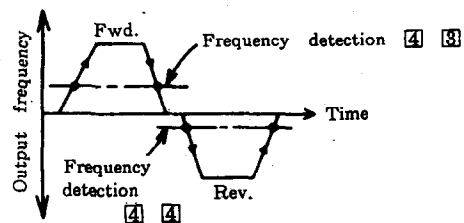

FREQUENCY METER CALIBRATION

Frequency meter calibration [C-1]

Frequency meter can be calibrated, without use of calibration potentiometer, by operating the PU.

(For method, refer to 5.1.)

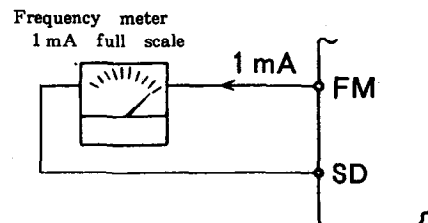

FM terminal output basic frequency [3] [8]

A pulse train signal is output from terminal FM. When a digital counter is connected to terminal FM, frequency can be monitored through the digital counter. Inverter output frequency at 1440Hz of pulse train signal can be set.

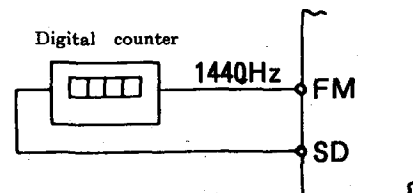

Note: The initial setting is that 1 mA full scale is read and pulse train signal frequency is 1440Hz when the output frequency is 60Hz.

OUTPUT FREQUENCY ADJUSTMENT

Bias for frequency reference voltage signal **C-2**

Gain for frequency reference voltage signal **C-3**

Bias for frequency reference current signal **C-4**

Gain for frequency reference current signal **C-5**

Output frequency ramp for any frequency reference signal as follows (DC 0 - 5 V, 0 - 10V, 4 - 20mA) can be set.

BIAS

Output frequency can be set for frequency reference signal input through terminals 2 and 5 (or 4 and 5).

GAIN

Output frequency can be set for frequency reference signal input through terminals 2 and 5 (or 4 and 5).

When frequency reference signal is 0 V, the signal is judged to be 5 V (or 10V), or 20mA.

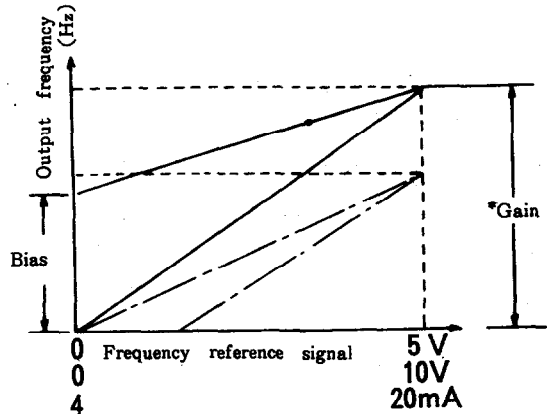

* When this gain is specified, value set for "frequency at 5 V input voltage" (function No. 20) or "frequency at 20mA input" is changed correspondingly.

§ 10. PARAMETER UNIT SPECIFICATIONS

	Description
Ambient temperature	Operating temperature -10 to +50°C
	Storage temperature -20 to +65°C
Ambient humidity	Less than 90%RH
	To be free condensation
Environment	To be free from oil mist, corrosive gas and dense dust
Cooling method	Self-cooling
Connection	Direct installation to FR-Z series inverter, or connection with special cable
Power supply	Fed from FR-Z series inverter
Display	4-digit 7-segment LED readout and indicator lamps
Operation	24 keys (protected with polyurethane film) are operated.
Outside dimensions	150mm (high) × 70mm (wide) × 16mm (deep)
Weight	0.1kg
Max. WRITE cycles	100,000 cycles

§11.OUTSIDE DIMENSIONS

● Parameter unit

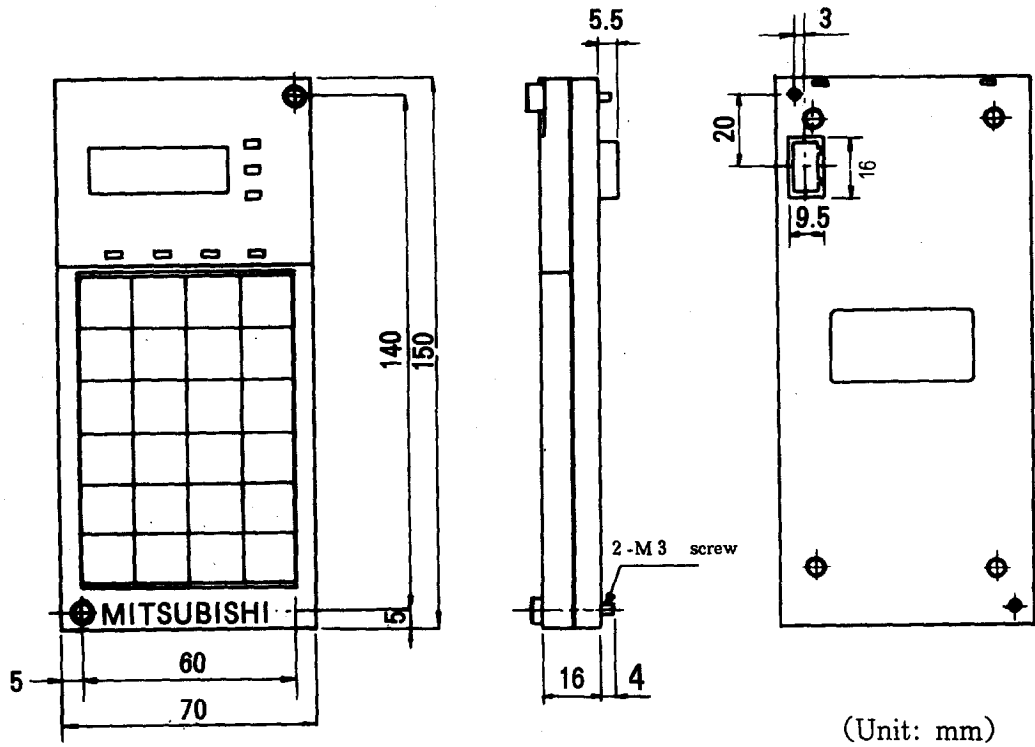

● Cable (option)

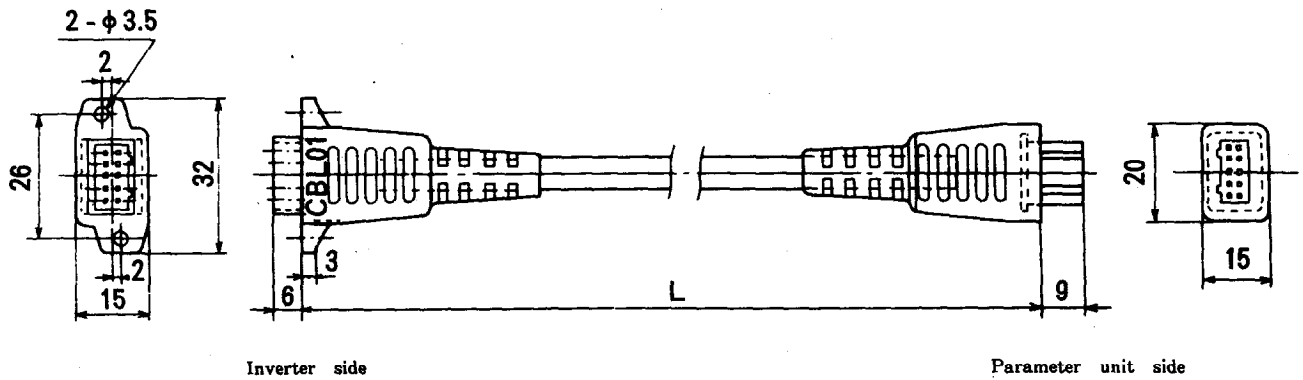

Model	L (m)
FR-CBL01	1
FR-CBL03	3
FR-CBL05	5



HEAD OFFICE: MITSUBISHI DENKI BLDG. MARUNOUCHI TOKYO 100 TELEX: J24532 CABLE MELCO TOKYO