

AN AMERICAN RIFLEMAN REPRINT



REMODELING ...

The .303 Lee-Enfield Rifle

Complete information, with exploded parts views on the various models, on disassembly, inspection, and adjustment, on remodeling into deluxe sporter, and on handloading the .303 cartridge. Also, plans for a gun rack.

THE AMERICAN RIFLEMAN is the official journal of The National Rifle Association of America (NRA). Its readership is well defined and essentially has a strong common bond of interest in firearms, ammunition, their appendages, and their legitimate use — on the target range, in the hunting fields, and as items to be acquired, collected, and enjoyed.

The NRA is a nonprofit organization (founded in 1871) supported by the membership fees of public-spirited citizens. Its purposes are to educate and train citizens of good repute in the safe and efficient handling of firearms; to foster a knowledge of small arms and the ability to use them among members of law enforcement agencies and the armed services, and all other citizens who would be subject to service in the event of war; to promote social welfare and public safety, law and order, and the national defense. Membership in the NRA is available to any reputable citizen of the United States upon nomination by a current member. Membership dues are \$5 a year, \$9 for two years, \$12.50 for three years. Life Membership is \$100.

For further information, write the NRA at 1600 Rhode Island Ave., N. W., Washington 6, D. C.



50 CENTS

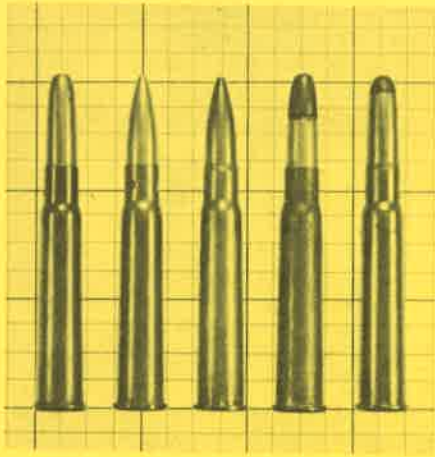

1 Some .303 cartridges (l. to r.): Mk. VI, Mk. VII, Mk. VII of U. S. manufacture with lip crimp instead of stab crimp, sporting with Westley Richards capped bullet (one of several types made in England), and sporting with soft-nose bullet (general type made in U. S.)



2 Lee-Enfield Mk. II. Weight about 9 lbs., over-all length 49½", barrel length 30¼". Rounded-corner rifling of Metford type originally devised to minimize black-powder fouling, and appropriate in this rifle since original .303 loading was compressed pellet of blackpowder. This model, introduced in 1892, differs from original Mk. I of 1888 principally in 10-round instead of 8-round magazine and in simplified bolt. Smooth outline of action top is due to absence of charger-loading guides and to steel dust cover which moves with bolt



3 Charger-loading Lee-Enfield Mk. I* (CLLE), or long Lee-Enfield. Weight about 9.4 lbs., over-all length 49½", barrel length 30¼". This model, an improvement of the magazine Lee-Enfield Mk. I (MLE) introduced in 1895, has safety lock which appeared in Lee-Enfield Mk. II* in that year, and deep broad-land rifling required to resist cordite erosion. Charger-loading guides were added to existing rifles in 1907

THE .303 LEE-ENFIELD

By Col. E. H. Harrison, USA (Ret'd)

NRA Technical Staff

THE standard military rifle of the British Empire and the present Commonwealth was, from 1888 onward, the .303 Lee in various models. Not until 1954 was it replaced, and then only with a self-loading rifle. No other breech-loading rifle and cartridge have been the standard of a major power for so long.

The gradual rearming of British Commonwealth forces with self-loading rifles resulted in large numbers of Lee-Enfield rifles coming on the American market. The construction and characteristics of the rifle and cartridge thus became of considerable practical interest.

While the basic rifle design preceded the cartridge, it is convenient to consider the cartridge first (see Fig. 1).

Among original military small bores

The .303 rifle cartridge was among the original military 'small bores', and dates from 1888. It is contemporary with the 7.9x57 or 8 mm. Mauser cartridge which also appeared that year. The 8 mm. Mauser proved much the better design in the long run, especially for automatic arms. Even for hand-operated magazine rifles its rimless form is better. The choice of a flanged case for the .303 was thus a mistake, in spite of certain advantages of that form which

then seemed more important. There is, however, very little in it for the user of a .303 rifle to become concerned about. The rifle handles this cartridge excellently, and to the user it will make no difference in practice.

Like most cartridges, the .303 has been produced in various loadings. The usual British smokeless rifle powder is cordite, adopted for this cartridge in 1892. The first bullet was of special round-nosed form and was long and heavy, weighing 215 grs. Mark VI ammunition, in which a bullet of this weight is given a standard muzzle velocity of 2060 feet per second (f.p.s.), is still often encountered. The present standard military cartridge, the Mark VII, was adopted for the trajectory flattening obtainable by pointing and lightening the bullet, and firing it at higher velocity. The Mark VII bullet is flat-based and pointed, weighs 174 grs., and is given a standard muzzle velocity of approximately 2440 f.p.s. An unusual feature is the bullet construction, in which the space under the jacket point is filled with a plug of aluminum, fiber, or paper for lightness. This is necessary to obtain the desired pointed form and length within the desired weight. If that space had been left solid the bullet would have weighed about 196 grs.,

reducing its velocity undesirably.

The .303 military ammunition has been regularly loaded with a large Berdan primer which contains both mercury fulminate and potassium chlorate. The mercury affects the strength of the brass cartridge case on firing, making it unsuitable for most reloading. The chlorate on firing leaves a deposit of salt on the rifle bore which will rust it badly if not promptly cleaned out. Water is the best solvent of this salt; hot soapy water cleans well and is easily wiped out before oiling. It is not always possible to clean soon enough to prevent some damage. The continued manufacture of such primers, in the face of modern chemical knowledge and the availability of reliable noncorrosive primers, can fairly be called backwardness.

U. S. sporting ammunition

Sporting ammunition for the .303 has been manufactured in this country (regularly in reloadable cartridge cases) since about 1897. It is made to supply not only imported Lee-Enfield rifles, but also U. S. and Canadian rifles of this caliber. These latter rifles are no longer made, but numbers are still in use. These and the large number of military Lee-Enfields can be expected to warrant
(Text continued on page 4)



4 Lee-Enfield No. 1 Mk. III* (SMLE). Weight 8¾ to 9 lbs., over-all length 44½", barrel length 25¼". Stocked to muzzle, with heavy nose cap. Barrel unusually light. Bore diameter .303"-.305", groove diameter .313"-.319", lands and grooves of equal width, rifling twist 1 turn in 10" left. Rifles of early manufacture have the very unusual feature of bore and groove diameters increasing toward muzzle which with Mk. VI bullet was found to raise muzzle velocity to about that of long Lee-Enfield rifle. Marks I, II, III, and IV are almost equivalent. Mk. V is equivalent except rear sight is peep with graduated folding leaf on receiver bridge

5 Lee-Enfield No. 4 Mk. I*. Weight 8¾ to 9 lbs., over-all length 44½", barrel length 25¼". Rifling same type as Mk. III, but bore diameter smaller. Differs from Mk. III principally in heavier receiver, heavier barrel, peep sight, simpler stocking, and design for simpler manufacture. Mk. VI was prototype. No. 4 Mk. I was type first manufactured, and differs from Mk I* in bolt-head catch and in rear sight having graduated folding leaf with fine elevating screw. Mk. I* may have either simple 2-leg sight shown or graduated folding leaf with notched catch. Mk. I (T) and Mk. I* (T) are telescope-sighted types provided for sniping. Mk. II is type manufactured after World War II; it is like Mk. I except for trigger mounted in receiver instead of in trigger guard, and return to peacetime production standards and finish. Rifle No. 5 or "jungle carbine" is World War II modification of No. 4 design for use in Pacific theater, principal changes being shortened barrel with flash-hider, shortened fore-end and handguard, and shortened buttstock with small recoil pad

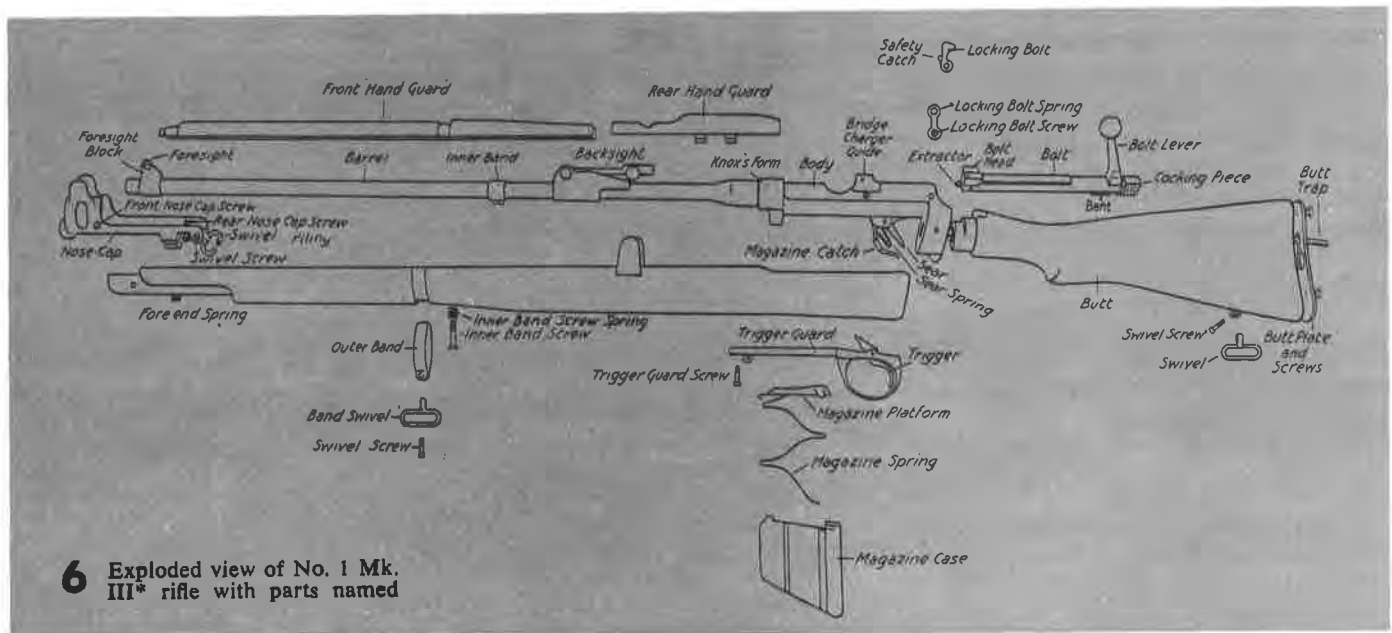

6 Exploded view of No. 1 Mk. III* rifle with parts named

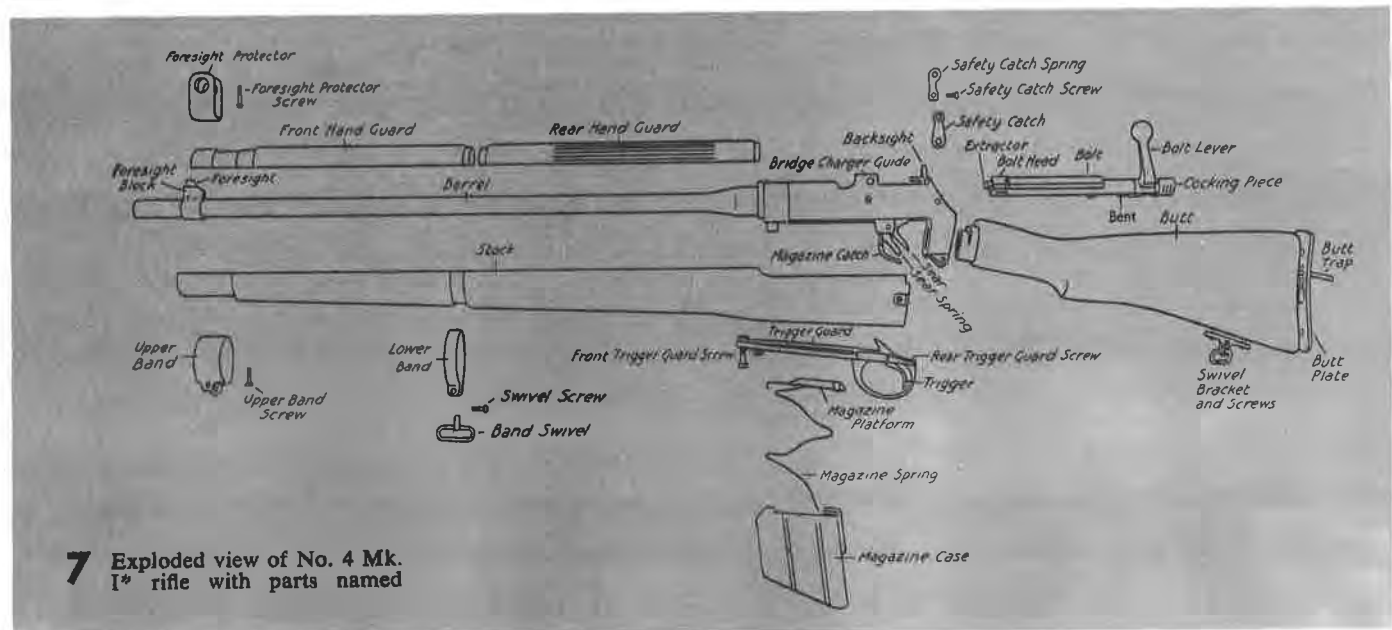

7 Exploded view of No. 4 Mk. I* rifle with parts named

commercial production of the ammunition for a long time.

Commercial .303 loadings are:

Make	Bullet (grs.)	Velocity (f.p.s.)
Norma	130	2790
CIL*	150	2720
Norma	180	2410
CIL	180	2540
Winchester, Remington, CIL, Norma	215	2180

*Canadian Industries, Ltd.

These constitute an excellent range of bullet weights and velocities for North American game. Except for the lighter Norma 130-gr. and 180-gr. loads, the above are almost exactly the same as the original commercial loadings of the .30-'06 cartridge with which its reputation on game was established. With suitable bullet types, the .303 has been successfully used on big game all over the world.

.303 adapted to handloading

The .303 cartridge is well adapted to handloading. THE AMERICAN RIFLEMAN has published 2 articles on the subject with laboratory-tested loading data. Cartridge cases (for American primers) and bullets are regularly available.

The .303 Lee-Enfield is well adapted for making into a sporting rifle. A .303 sporter is unusually short, light, and easily handled, for one made on a military base. Simple sporterizing has been described in THE RIFLEMAN. Something is worth mentioning here which is not often spoken of. It has very often happened that the new owner of a military rifle has hastened to 'improve' or 're-model' it, only to find himself a little later disillusioned and then ashamed of the quality of his work. It is better to take some time first for understanding the rifle, and then to develop a well-considered plan for what is wanted.

Lee-Enfields produced in peacetime were made with great care and very well finished. Those of wartime production were rougher finished. This is especially true of the No. 4 rifle, the principal model of World War II. However, the materials quality, functioning, safety, and durability were always maintained. Since World War II, manufacture of the latest model of the No. 4 military rifle has tended to return to peacetime standards. In the meantime, buyers should remember that in all surplus military rifles, condition varies greatly between specimens. This has nothing to do with rifle type, but depends simply on service and care the individual piece has had.

In peacetime the Lee-Enfield has also been produced and refinished commercially in military models for long-range

target shooting, and in sporting models for game shooting. Such rifles are excellently and often beautifully made.

Rifle characteristics

The action of the Lee-Enfield is based on a design by an American named Lee. It differs materially from the Mauser types which, beginning with the Springfield, have been the basis of most American bolt-action sporting rifles. The bolt handle is behind the trigger, not forward of it as in the Mauser. The bolt head is separate from the bolt body, and does not turn. The bolting surfaces are near the middle of the receiver behind the magazine, not forward of it as in the Mauser. The firing pin is cocked almost entirely by the final push-forward of the bolt, not principally by the bolt-handle lift as in most Mausers.

The magazine holds 10 rounds instead of 5 as in the usual Mauser. It is detachable, but is usually left on the rifle and loaded from the top of the action in the same way as the Mauser. The buttstock and forestock are separate, not one piece as in the Mauser. The light barrel and the forestock construction of the Lee-Enfield bring on problems of barrel and action bedding which are peculiar to it, especially in the Mark III model.

These bedding problems are real, but have been overemphasized. Competition shooting with the .303 has been carried on regularly and very successfully for decades. For fairness to all, British and Commonwealth competition rules generally limit .303 rifle modifications and adjustments to parts fitting, mostly the woodwork, requiring only methods and materials available to any careful shot; and to ammunition of a single lot as issued to the firing line. While these rules have accomplished their purpose, extreme though unappreciated variations in quality of the issued ammunition since World War II have confused shooters and armorers and led them into complicated attempts to improve their rifles, where the basic trouble did not lie. With the realization of these facts in recent years, steps have been taken for selection of ammunition lots suitable for target shooting, and rifle stocking practices have tended to become simplified.

Basis of stocking

Now the basis of stocking is recognized to be the fit of the receiver in the wood, which is necessary to accurate shooting from almost any bolt-action rifle. The barrel may be bedded in various ways, or may be free-floated with good results. A brief summary of the particulars required in good stocking of Lee-Enfield rifles is given in Fig. 20.

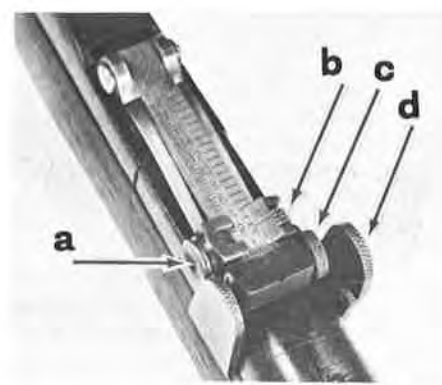

8 Rear sight of Mk. III rifle. Graduated from 200 to 2000 yds. with division each 25 yds. Elevation set by pressing in spring catch **a** and moving slide to range desired. Ramp is so made that range graduations are uniformly spaced. **b** is fine-adjustment worm wheel with notches of 5 yds. each. **c** is wind-gauge screw with 1-minute clicks; Mk. III* and later Mk. III sights have no wind gauge. **d** are guards fixed to barrel. Rifles previous to Mk. III* and later Mk. III also have long-range sights consisting of swinging arm and peep on left side of receiver, and front sight on left side of fore-end with adjustable dial for range setting

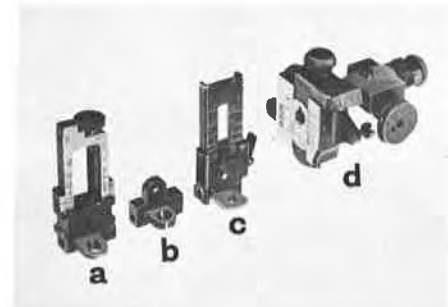

9 Rear sights of No. 4 rifle. **a** is Mk. I sight, for Mk. I and Mk. II rifles; elevation screw has 1-minute clicks, and fixed aperture appears when sight is folded down; there is no wind gauge. **b** is Mk. II sight for Mk. I* rifles, a 2-leg peep for 300 and 600 yds.; it is simple and effective hunting sight also, and is zeroed by moving front sight laterally and changing its height. **c** is Mk. III alternate rear sight for Mk. I* rifles, like Mk. I but wartime construction and slide settable only at notches. **d** is English micrometer receiver sight used in matches which permit target sights. Similar sights are available for Mk. III and long Lee-Enfield rifles. The English and Australian target sights are handsomely and strongly made, with clean and positive click action

10 Bolts of all Lee-Enfield rifles are stopped at end of travel by bolt head striking right locking abutment. To remove bolt of MLE, CLLE, and SMLE rifles, pull all the way back, then with thumb push bolt head over its spring catch to vertical (see arrow) and bolt is then free to be pulled out of receiver





11 To remove bolt of No. 4 Mk. I rifle, first depress bolt-head catch (see arrow). While holding catch down, pull bolt all the way back; release catch, and bolt head can then be turned to vertical and bolt pulled out



12 To remove bolt of No. 4 Mk. I^a rifle, pull bolt back about 1" until bolt head is at dismount notch (see arrow), turn bolt head to vertical and pull bolt out

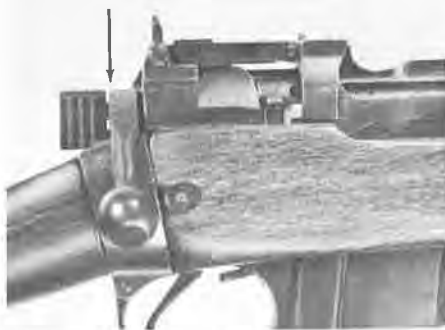

14 Striker in forward position is stopped by its above-mentioned shoulder abutting rear of bolt head. Cocking piece then clears rear of bolt (see arrow). Do not attempt to remove this clearance, since if it were not present the cocking piece would strike bolt and eventually break striker rod



15 Safety lock when put to "on" should push cocking piece back a small but clearly visible amount (see arrows). This action withdraws cocking piece from contact with sear. It is necessary in all bolt-action rifles since otherwise pulling trigger with safety on would leave sear held down by cocking piece, and rifle would then fire when safety was turned to "off"

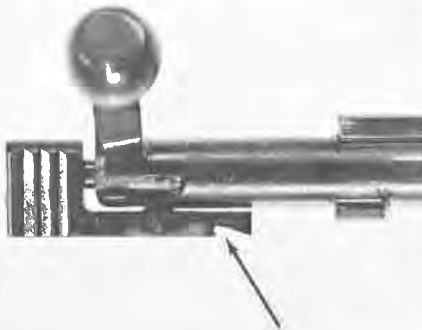

16 The Lee-Enfield has a 'half-bent' or half-cock notch (see arrow), a very unusual feature on bolt-action rifles. It is safety device required by short cocking cam of this action. Should trigger be pulled with bolt not rotated closed, cocking piece would be caught and held by this notch, and firing thus made impossible. Cocking piece and bolt are then locked, and can be released only by drawing cocking piece back by hand. (Should trigger be pulled with bolt handle only slightly raised, striker will fall and through cocking cam complete closing of bolt as in Mauser-type rifles.) The half-bent is not provided as safety for carrying except in early-type Lee-Metfords, and its use for that purpose is rather clumsy

17 Magazine follower spring and inside of magazine should be thoroughly cleaned of preservative grease, to avoid attracting dust and to prevent stiff action when cold. Press rear end of follower down until front end clears (see arrow a), and lift follower and spring out. Some magazines contain an auxiliary spring, which should be left in place. Note that some states in U. S. prohibit hunting big game with rifles having magazine capacity of more than 5 rounds. Therefore check regulations in your area before hunting with this 10-round magazine and if necessary place wood block in bottom of magazine to reduce capacity to 5 rounds. Since No. 4 rifle is made for Mk. VII ammunition with pointed bullet, it may be necessary to de-burr forward lips of magazine (arrow b) carefully to get smooth feeding of Mk. VI and sporting ammunition with round-nose bullet. Magazines are not interchangeable between long Lee-Enfield, No. 1, and No. 4 rifles

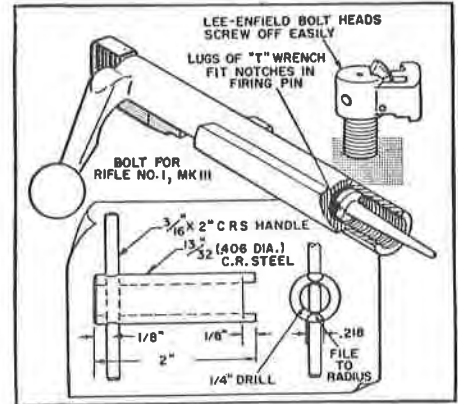

13 Bolt disassembly requires removal of striker from cocking piece (except in very early rifles), which must be done from front. Turn cocking piece to bottom of cam at rear of bolt, which takes most of compression off mainspring. Turn bolt head off, look into open front end of bolt and note 2 notches on opposite sides of striker shoulder, 1" back from point. These provide grip on striker by necessary tool which must be used and if not at hand must be made (see cut). Remove striker locking screw from rear of cocking piece. Turn out striker from front with the tool shown, and drop out mainspring. Attempts to turn out striker with pliers or other gripping tool occasionally succeed, but normally this is impossible and results only in injuring or breaking striker point. Cleaning requires no disassembly of bolt, since with bolt head off the inside is open for washing out with solvent

The prospective user of a Lee-Enfield may wish to give consideration to opposing views of it which have been held.

A view, often given expression by writers in the United States, contrasts the Lee-Enfield unfavorably with the Mauser with which they are familiar. This is based principally on location of the bolt locking lugs, which in the Lee-Enfield are behind the midpoint of the bolt rather than at the bolt head as in the Mauser. This makes the action less suited than the Mauser for high-intensity cartridges and the most accurate shooting. Other objections are cocking on closing the bolt, which is disliked by such American shooters as have been trained on the Mauser type, and unfamiliar appearance.

The point made as to location of locking lugs is correct. The effect is due not to their location on the bolt, but to the locking surfaces in the receiver being behind the large asymmetrical magazine and loading openings. The resulting uneven-sided bolting affects the barrel vibration during discharge, making it (when other things are equal) less uniform than that of the Mauser.

The British readily admit the above, while noting it has not prevented long-continued successful use of the Lee-Enfield in long-range target shooting.



18 Lee-Enfield trigger is carried in trigger guard, not in receiver. Changes in condition of stock wood, tightness of forward guard screw, etc., therefore can affect trigger pull. Cut shows relationship of trigger and sear which should be maintained for correct trigger action. Trigger here shown with second-pull hump (see arrow) not yet in contact with sear, since first-pull hump is within guard frame. Exception is No. 4 Mk. II, in which trigger is mounted in receiver. There is no trigger spring in any Lee-Enfield and none is needed



19 Buttstock is fastened with stock bolt, reached through butt trap with a long, strong screwdriver. First the wad must be removed, which is fiber disk at bottom of butt recess to prevent metallic noise from brass oil bottle regularly carried there. Stock bolt must be kept solidly tightened. Butt tenon should fit tightly in socket; fit should be restored with layer of hard paper around tenon if required. In this photograph a is sear, b is magazine catch

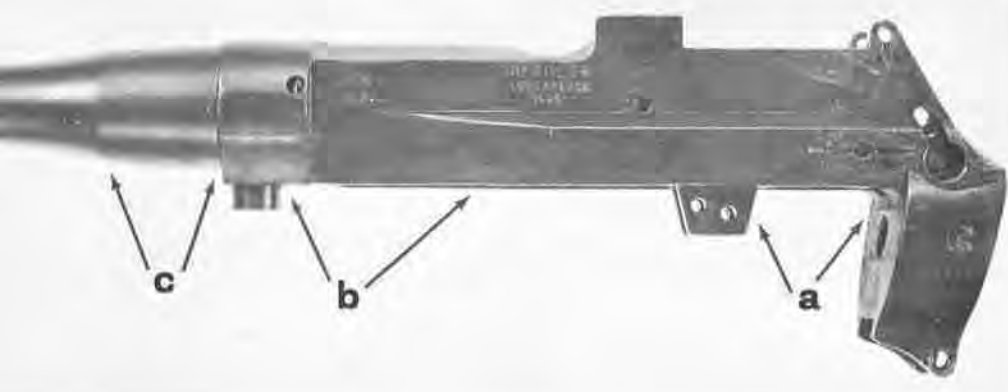

20 For good shooting, fore-end must be bedded tightly where indicated by arrows (shown here on No. 4 stripped barrel and receiver for clarity). When correctly fitted, it cannot be pulled straight off by hand; it must not be pried off by swinging forward end away from barrel as that will spoil bedding. To remove, first remove trigger guard and fore-end furniture (including inner band screw on Mk. III); then tap downward with wooden block and mallet on fore-end at sides of action, keeping fore-end parallel with barrel. (On No. 4 Mk. II rifle also remove cross screw at rear of fore-end.) Bushing around front guard screw should be of length to permit a small crush-up of wood there. Fore-end of Mk. III rifle must bear hard on slanted rear faces of sear lugs and fit tightly between sear lugs and butt socket (arrows a), with good bearing around front guard screw extending not less than $1\frac{1}{2}$ " to rear along sides of magazine opening (arrows b), in central bearing $\frac{1}{2}$ " wide for length of cylindrical part of barrel (arrows c), for $\frac{1}{2}$ " ahead and behind inner band (not shown), and lightly from inner band forward to fore-end tip when rear nose-cap screw is tightened. Fore-end and hand-guard must be entirely clear of barrel elsewhere. It should be possible, by inserting a bullet in the muzzle, to raise barrel .004" within the nose cap, and it should then return to the lower position. Fore-end of No. 4 rifle must fit similarly at arrows a, b, and c, and in central bearing $\frac{1}{4}$ " wide for length of raised seating in fore-end tip; alternatively fore-end tip bearing may be omitted and barrel free-floated. These are the regulation beddings. Some armorers practice bedding at other points and packing of hand-guards as well, but with reliable ammunition it has become appreciated that regulation bedding gives results substantially as good or nearly so

22 No. 4 rifles are zeroed laterally in same way, but most have special front sight lock screw (see arrow) which must first be loosened, then sight can be moved by hand without need of tapping. Do not attempt to move sight without loosening lock screw. Note that screw has rib across its head instead of slot, and special screwdriver is required. Make this from $\frac{3}{16}$ " drill rod, by sawing slot across end of rod with 2 blades in hacksaw to obtain correct width of cut. Moving sight $\frac{1}{64}$ " displaces impact about $2\frac{1}{2}$ " at 100 yds.

They generally consider, however, that it is more than overcome by certain practical advantages of the Lee-Enfield. Among these are its short bolt throw, about 1" shorter than that of a Mauser for the same length of cartridge. The bolt handle is easier to reach than that of the Mauser, and does not have to be lifted so high. The action is shorter than that of the Mauser, and the rifle correspondingly shorter and handier. The 10-round magazine is a material military advantage. Those who have witnessed rapid aimed fire with the Lee-Enfield in the hands of men trained with it, find it a revelation for speed and rate of hits. The rifle is strong and reliable.

While the above points on both sides are interesting and instructive, I believe they would be considered quite inadequate by the British and Commonwealth authorities whose view has been given effect. The rifle has been viewed by them from the standpoint of its purpose, which is fighting. The following 2 paragraphs give something of how it is considered in that light.

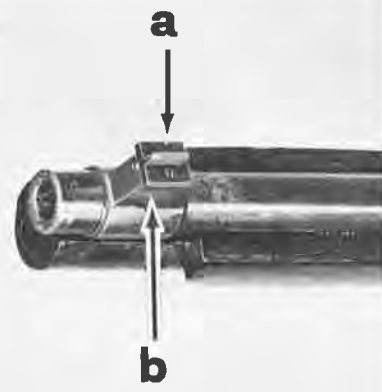

21 Mk. III rifles, other than old rifles with wind-gauge rear sights, must be zeroed laterally by moving front sight, as in most military and sporting rifles. Move front sight opposite to way impact is to go. Remove nose-cap before making adjustment. Note witness mark on sight and base. Moving sight $\frac{1}{64}$ ", which can readily be measured by the mark, moves point of impact about 3" at 100 yds. Sight is moved to side by setting brass or fiber drift against it (see arrow a) and tapping the drift, not the sight direct as that would mar it. Support sight base solidly while doing this (see arrow b) to avoid loosening it on barrel



Before World War I, the authorities actually did come to the opinion that something different was wanted. This was in the first place a matter of the cartridge, something much flatter-shooting than the .303 being desired. Accordingly a powerful, high-velocity cartridge of cal. .276 was adopted, with a Mauser-type rifle for it designated the Pattern 13. Due to the outbreak of World War I at that time, this rifle was used by the British in cal. .303 only, as the Pattern 14 or Rifle No. 3, and by the United States in cal. .30-'06 as the U. S. Model 1917.

World War I provided by far the greatest test of hand-operated rifles that has ever taken place or apparently ever will. In that experience the British lost their desire for a Mauser-type rifle, finding the Lee-Enfield more reliable in the mud and other adverse conditions of that war. The Lee-Enfield also delivered the more effective fire. They consider these results amply confirmed by experience elsewhere, including World War II. The Lee-Enfield has had large-scale use over a greater part of the world than any other single rifle.

To summarize, the Lee-Enfield has been a remarkable military success under the widest variety of conditions. It has long given good results in sporting rifle form, and when skillfully bedded, as a long-range target rifle. Provided its cartridge is appropriate for the intended use, the American user should choose it if he likes it, without regard for expressions of some individual opinions which have been printed as to whether it is 'suitable for American conditions' or the like.

Detailed consideration of the Lee-Enfield requires identification as to types. For most purposes it is sufficient to note the 3 main groups into which these rifles have been divided:

1. The long magazine Lee-Enfield (MLE) and charger-loading Lee-Enfield

23 No. 4 rifle front sight protector screw (see arrow a) must be kept tight, since looseness of protector on muzzle will cause poor shooting. Do not interchange front sight protector screw and rear guard screw; this can be done by inadvertence but result is unsatisfactory. Clearance must be left between front sight protector and ends of fore-end and handguard (see arrow b), since contact there will affect shooting

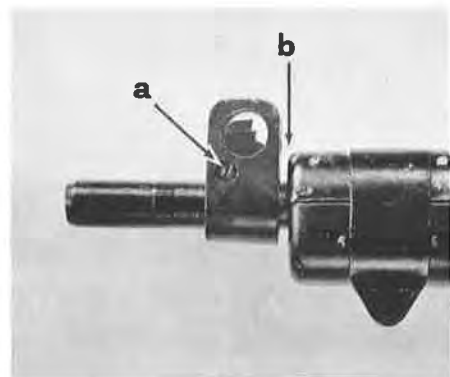

(CLLE), also including as a matter of convenience the first .303 magazine rifles which had rounded-corner rifling and were designated Lee-Metfords. There are carbine models of these rifles. The Lee-Metford underwent replacement of the original 8-round magazine with one for 10 rounds, and introduction of a safety lock. Most important improvement of the long Lee-Enfield was clip loading. The long Lee-Enfield was very popular for both military target shooting and for manufacture of sporting rifles, and some are still in use.

2. The short magazine Lee-Enfield (SMLE), or Rifle No. 1, adopted in 1902. Its main distinguishing characteristics are the single 25" barrel length used by all services, and the distinctive stocking. Most manufacture was between 1907 and the end of World War I. There are several marks of SMLE, but the Mk. III is the principal and the others are substantially equivalent to it, hence the designation Mk. III is commonly used for the whole group. The only significantly different No. 1 rifle is the Mk. V, which introduced the peep sight. A .22 training model of the Mk. III is called the Rifle No. 2.

3. The Rifle No. 4, which is in effect an SMLE with peep sight, heavier barrel, simplified fore-end, and numerous small changes to simplify manufacture. This is the model of World War II manufacture and later.

Considerable changes in detail

There is a considerable number of marks in each of the above rifles, reflecting the fact that in their long history there have been many modifications and improvements, most of them minor. The Lee-Enfield was standard during much of the time the United States had 4 military rifles—the .45 Springfield, the Krag, the .30-'06 Springfield, and the M1. Rather than such radical changes, the British made only changes in detail. A considerable number of detail changes was made in the U. S. military rifles during that period, most of which were not recorded in model designations, while such changes were regularly signaled by new marks in the .303. In any event, the various marks have little practical interest for the average user, with the exception that they may have an important effect on interchangeability of parts. —■

"REMODELING THE 03A3 SPRINGFIELD" is an AMERICAN RIFLEMAN Reprint giving complete information on making 'economy' sporter, deluxe sporter, match rifle, on parts and assembly, and on drilling and tapping. It includes an "exploded view" drawing of this popular rifle. Price, 50¢, from NRA Headquarters.

RANGE PLANS

ONE of the finest contributions any individual or club can make is to provide a community with a safe, adequate 'Place to Shoot'.

The NRA has a number of brochures and manuals on range construction and shooting arrangements. Listed below are some of the most popular.

Construction of Indoor Rifle and Pistol Ranges



A 16-page manual of recommendations for basic indoor range construction. Aspects of construction discussed include site selection, safety, space requirements, bullet-stops, bullet-protecting plates, target carrier systems, lighting and ventilation, noise control, and range equipment. A list of sources of range equipment—bullet traps, range lighting, sound-absorbing materials, and target carriers—is included. Price: \$1.00

Outdoor Smallbore Rifle Range Plans

A suggested layout of club house and outdoor smallbore rifle range for shooting at 50-yd., 50-meter, and 100-yd. targets, including firing line covers, target scoring racks, bulletin boards, and a range house. The range builder can use all or part of the suggested layout. A plan is given for the Universal outdoor smallbore rifle target frame, now used at the National Matches at Camp Perry, Ohio. A lighting system for outdoor night shooting is also illustrated. Price: 50¢

Outdoor Pistol Range Plans

Drawings of 3 plot plans for a 20-target pistol range complete with turning targets. Drawings of target frame construction for the Colt silhouette target and the Standard American target and target operating details are included. Price: 50¢

High Power Rifle Range Plans

Twelve pages of over-all range dimensions and details of range construction, including vertical and horizontal type target holders. Dimensions of 5 types of firing line covers, some new and efficient scoring systems, and detailed plans for an underground 100-yd. test range complete the booklet. Price: 75¢

1 Rifle No. 4 Mark I



2 Completed rifle, less sling, weighs 7 lbs. 13 ozs. Fajen semi-inletted stock used for rifle shown has high Monte Carlo cheekpiece which could be omitted to save some weight. Accessories include Jaeger quick-detachable sling swivels, and Boyt 1" sling. Sights are Redfield 40S ramp front assembly with detachable hood and Redfield 80-OMT aperture rear attached to Redfield adapter plate. Front sight height is .630" for 22" barrel



FOLLOWING adoption of the FN self-loading rifle by Great Britain and other Commonwealth nations, large quantities of cal. .303 British Service Lee-type magazine rifles have appeared on the American market, and at attractively low prices considering their quality and durability. The rather bewildering array of models offered date from 1888 up to the latter years of World War II, all chambered for the same cartridge case.

The most common models are those produced from about 1902 on and generally classified as SMLE (Short Magazine, Lee-Enfield) rifles. While there are many minor construction differences in the various SMLE models, they have certain common characteristics, including 10-shot detachable box magazines, cock-on-closing bolts, 2-piece stocks, and similar receiver construction. Rifles in this group are particularly suitable for conversion to sporting type and, assuming good workmanship, the finished product will compare favorably with commercial sporting rifles.

The home craftsman can accomplish the entire conversion using hand tools only and none of the operations involved is particularly difficult. Rebluing of the barreled action is best handled by the professional gunsmith or rebluing establishment as it will not pay the individual to purchase rebluing tanks, chemicals, etc., unless he intends to reblue many guns. The various swab-

Deluxe Sporterizing The No. 4 Rifle

By M. D. Waite
NRA Technical Staff

on or touch-up blues offered are not adequate for complete finishing.

The skillful amateur gunsmith may save a portion of the rebluing charge by doing his own polishing. In any event, the barreled action should be inletted into the stock after polishing and prior

to bluing if close fit between wood and metal is desired. Inletting of the blued assembly is difficult to accomplish without marring the finish.

Action and barrel modifications

Partial removal and rounding of the clip bridge will greatly enhance appearance of the action and is readily accomplished by grinding or filing. Also, the rather bulky trigger guard bow is made more attractive by removal of excess metal. Shortening the magazine box to 5-round capacity and fitting a floorplate to the trigger guard is a recommended modification which may be mandatory in those states limiting magazine capacity of sporting rifles. Reduction of barrel length to about 22" will enhance the handling qualities of the rifle and simplify fitting of ramp-type sporting sights.

Sighting equipment

A variety of fully-adjustable metallic rear sights, in a relatively wide price range, is available for SMLE rifles. Some require drilling and tapping of

3 M. D. Waite fits the forearm during the making of the deluxe sporter version of the No. 4 rifle. All work in making the sporter (other than bluing) was done in Editorial Division Shops by Staffman Waite. The gunsmithing articles by the NRA Technical Staff which appear in THE RIFLEMAN are all based upon projects that have been done in these shops, as are evaluations of items which appear in the Dope Bag



the receiver for installation whereas others can be mounted using a screwdriver only. It should be noted that the receiver-mounted Service sights on SMLE rifles and carbines are well designed for sporting purposes even though they do not incorporate windage adjustments. If retained, a front sight assembly should be chosen permitting lateral adjustment of the blade or bead so that the rifle can be conveniently zeroed for windage.

Ramp-mounted front sights are offered in band, screw-on, and sweat-on types, with the last the most difficult to install since there is some risk of bore damage unless proper precautions are taken. The band ramp is the easiest to install and align and is thus recommended.

Bolt handles of SMLE rifles do not require alteration for use with scope sights. Scope mounts are available for positioning scope offset to left or above metallic sight line.

Caliber changes

The mean working pressure of the .303 British cartridge is about 45,000 p.s.i. or slightly greater than that of the .30-40 Krag. Gunsmiths have reported that rebarreling of the SMLE action to cal. .30-40 Krag is feasible, but this conversion appears illogical in that the .303 British cartridge is ballistically superior and is also currently manufactured in the U. S.

Nothing is known at this time concerning use of SMLE actions with more powerful rimless cartridges such as the 7.62 mm. NATO (.308 Winchester).

8 Ordinary round-head brass or steel bolts, chucked in hand drill, are adequate for crowning or breaking sharp edges of rifling. Abrasive used is fine valve-grinding compound available from automotive stores. Drill should be held vertically with only slight handle oscillation and abrasive compound should be replenished frequently. Break sharp outer edge of muzzle with stone or fine-cut file after crowning bore

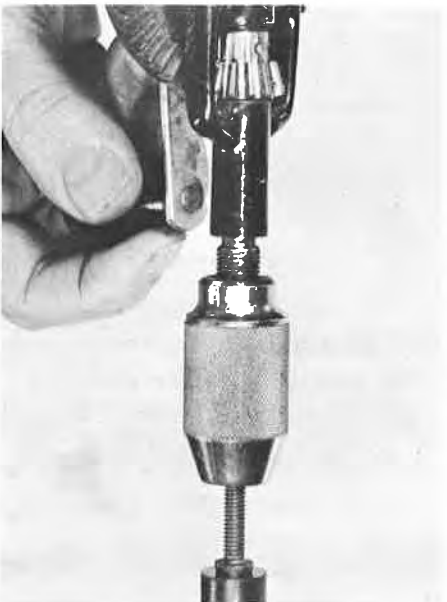

4 Typical semi-inletted (upper) and finished (lower) SMLE stocks as furnished by E. C. Bishop & Sons, Inc., and other U. S. stock firms. Only minor inletting is required to fit finished stock to rifle. Most stock suppliers will fit semi-inletted stock to customer's barreled action at nominal cost



5 SMLE buttstock is retained by long through-bolt threaded into socket at rear of receiver. Stock tenon should fit socket tightly. To fit buttstock, first check tenon length against socket depth to note if trimming is necessary. Then coat interior surfaces of socket with marking color (lampblack and oil, or Prussian blue). Rubber or rawhide hammer is then used to drive buttstock into socket, after which burnished high spots on tenon, as indicated by transfer of marking color, are scraped off with keen penknife blade. It may be necessary to make several impressions before hairline wood-to-metal fit at socket rim is obtained



7 After cutting barrel to length with hacksaw (high-speed steel blade recommended), true muzzle with fine cut mill file. Use small carpenter's or machinists square to check work, making due allowance for barrel taper. Polish filed surface with stone or fine abrasive paper backed by flat file

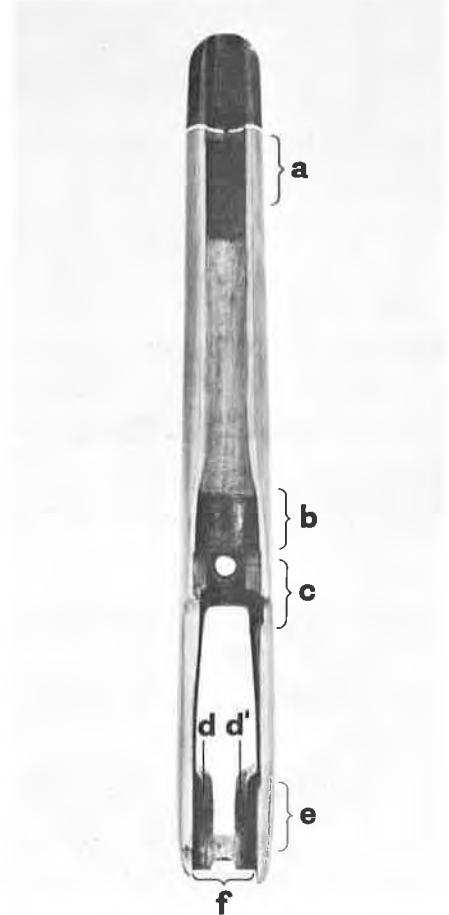

6 Forearm should contact barreled action at points indicated. Initial fit at point (a) should be quite tight to compensate for any subsequent loosening. Plastic forearm tip should not contact barrel. Barrel should bear against bottom of channel at (b). Receiver should bear against forearm at (c) and (e). Receiver rear lugs should bear evenly at (d) and (d'). Rear surface (f) should be tight fit against front face of receiver socket. It may be necessary to glue wood veneer shims at (d) and (d') and on rear face of forearm (f) to obtain snug fits. Original steel, or fiber, guard screw bushing should be used with new forearm

9 Correct depth of magazine is obtained by inserting it in rifle and then marking cut-off line flush with edge of magazine opening. After removing follower and spring assembly, use hacksaw to cut away lower portion of magazine

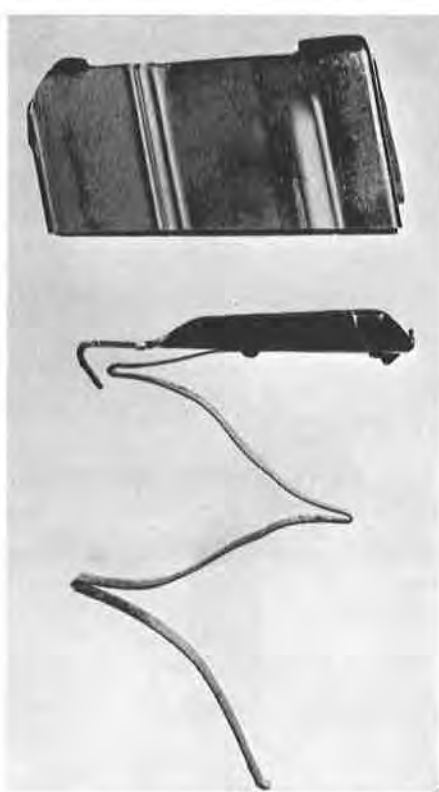

10 Modified magazine with the follower assembly. If follower spring proves too stiff during subsequent functioning trial of rifle, lash lower spring arm to center section with fine wire but do not sever lower arm as this may inhibit follower action. Magazine functioning is improved by polishing follower and deburring under surfaces of magazine lips with file or stone



13 Installation of scope sights on SMLE rifles requires drilling and tapping of several holes in receiver wall. Jaeger quick-detachable mount (upper) and Williams mount (lower) are furnished for SMLE rifles and can be used in conjunction with metallic sights. Williams mount can be obtained with rings to position scope over bore or offset to left



11 Appearance of trigger guard is enhanced if guard loop is modified by filing as shown. Floorplate made from sheet metal is retained by single screw and notch filed in guard loop. Top of floorplate can be filed to arched contour of factory-made plate. Forepart of guard tang shown was rebated to eliminate unsightly punch marks around guard screw hole

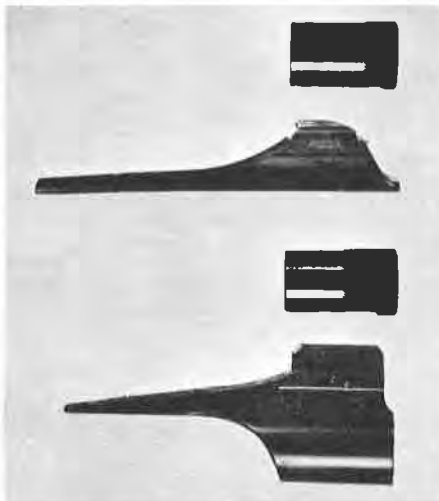

14 Williams detachable-hood stream-line ramp sight (upper) is offered for both screw-on and sweat-on mounting. Special short ramp style is available for Rifle No. 5 (Jungle Carbine). Redfield detachable-hood ramp sight (lower) has integral band to provide drive fit on barrel. It is retained by pointed locking screw installed under sight blade

16 Spanner wrench made from short section of $\frac{3}{8}$ " steel rod is required for bolt disassembly and assembly. Drill $\frac{3}{16}$ " hole in center to depth of $1\frac{1}{4}$ " and file twin lugs on end to engage notches on side of firing pin. Wrench is used through front of bolt after unscrewing bolt head and removing locking screw from rear of cocking piece

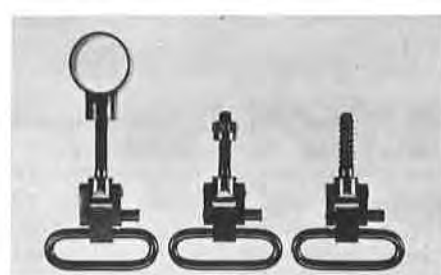

12 Jaeger quick-detachable sling swivels are typical of those available from several manufacturers. Butt swivel is on right with 2 different forearm swivels on left. Swivel assembly at far left is available with solid or split barrel band

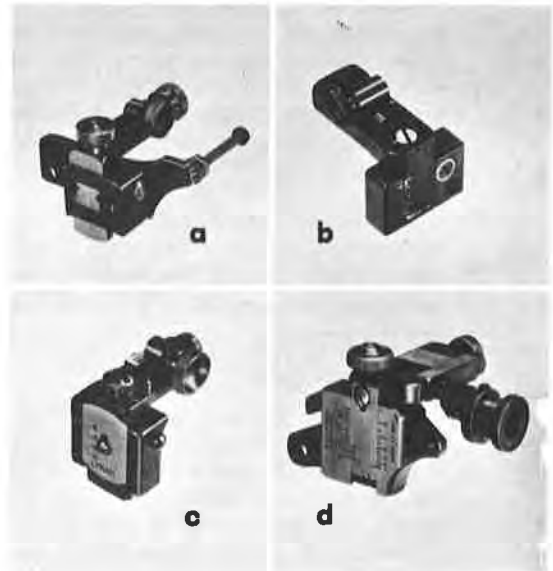

15 Several excellent aperture rear sights are available for SMLE rifles, some of which are shown here. Williams (b) and Lyman (c) sights require drilling and tapping 2 holes in receiver. Redfield sight (a) features auxiliary adapter mounting plate for screwdriver attachment to flat-sided SMLE receivers utilizing holes already present. British-made A. J. Parker sight (d) is primarily a target sight and calibrated for British Mark VII Service cartridge. It can be installed on flat-sided SMLE receivers utilizing holes already present. A variety of British-made sights are available for SMLE rifles but must be imported

17 Assortment of tools used for conversion shown. Files and rasps are for shaping stock and metal work. Small Swiss files, offered singly and in sets, are particularly useful for final shaping of trigger guard, etc., and for finishing sharply curved-surfaces around pistol grip, cheek-piece and comb. Scraper with round cutter head is handy tool for precise inletting of barrel into forearm



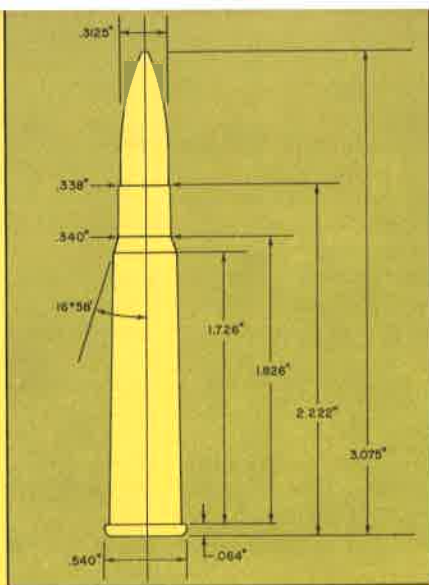

.303 British maximum cartridge dimensions

Loads for the .303 British

By M. D. Waite,
NRA Technical Staff

Ballistic data supplied by H. P. White
Laboratory

ALTHOUGH not overly popular in the United States, the .303 British nevertheless ranks as one of the world's most important small arms cartridges. When adopted in 1888 by Great Britain, it was loaded with 70 grains of compressed blackpowder to give a muzzle velocity of 1850 feet per second. The round-nosed cupro-nickel jacketed bullet weighed 215 grains.

In 1892 the blackpowder propellant was obsoleted in favor of a double-base smokeless powder known as cordite. The name 'cordite' was derived from the fact that the extruded powder grains were in the form of long strands or cords cut to extend the full length of the cartridge case powder chamber. This powder continues to be the standard propellant for British- and Canadian-loaded .303 service ammunition. Some .303 British military ammunition has been loaded both here and abroad with single-base nitrocellulose powders. This can be identified by presence of the letter 'Z' in conjunction with regular headstamp markings. American-loaded .303 British sporting ammunition is loaded with American granular powders rather than cordite.

Contemporary writers, with some justification, compare the ballistic efficiency of the .303 British with that of the .30-40 Krag, or .30 U.S. Army. Actually the .303 British is the more powerful round since its established

mean pressure is about 45,000 pounds per square inch as compared with 40,000 pounds per square inch for the .30-40 Krag. This permits loading of the .303 British cartridge to higher velocity levels even though its case capacity is slightly less than that of the .30-40 Krag. Also, the maximum permissible individual pressure is higher with the .303 British cartridge. This is in keeping with the greater strength of the British Short Magazine Lee-Enfield rifle action in comparison with the single locking lug, caschardened action of the U.S. Krag-Jorgensen.

There are no particular problems involved in handloading this cartridge. A reasonable assortment of foreign and domestic bullets is available to encompass all game from varmints to the largest animals found on this continent. Bullets of .308 inch (.30 caliber) can be used in .303 (7.7 mm.) caliber rifles but will usually provide only fair accuracy. The discrepancy between bullet and barrel groove diameter will result in appreciable velocity loss plus increased erosion due to gas cutting.

Loads 11 and 12 are identical except

for the brand of cartridge case used. Load 11 was assembled with cases of Remington make, whereas Norma reloadable cases of Swedish make were used for Load 12. Study of the firing data revealed identical velocities for the two loads but higher pressure for Load 12 featuring the Norma case. This inconsistency was resolved by refiring both loads with the cartridge cases drilled opposite the piston port in the pressure barrel chamber.

This was done to check on the possibility that a variation in hardness or thickness of the cartridge cases may have effected the pressure differential noted. Such proved to be the case as results obtained in refiring with Loads 13 and 14 are substantially identical.

The data for Load 15 will be of interest to Canadian marksmen as the ammunition was from the same lot issued at Connaught Ranges for use in the 1957 Canadian National Matches. This lot was loaded in 1950 by Dominion Industries using cartridge cases made in 1945. The extreme variation in velocity was 148 feet per second for the ten rounds tested.

LOADS FOR THE .303 BRITISH

LOAD				POWDER		RESULTS		
Bullet No.	Weight (grs.)	Bullet Type	Bullet Diameter (in.)	Overall Cartridge Length (in.)	Charge (grs.)	Type	Velocity (f.p.s.) Avg. of 10 rounds	Pressure (lbs. per sq. in.) Avg. of 10 rounds
1	130	(a) Norma soft-point pointed	.3115	2.851	46.5	3031	3004	44,000
2	130	(a) Norma soft-point pointed	.3115	2.851	50.5	4320	2976	43,220
3	150	(b) Hornady round-nose	.312	2.840	44.0	3031	2787	44,990
4	150	(c) Speer spitzer soft-point	.3115	2.957	40.0	HVal #2	2710	42,650
5	150	(d) Sierra spitzer	.311	2.945	48.5	4320	2808	43,830
6	180	(e) Speer round-nose soft-point	.311	3.000	39.0	HVal #2	2503	43,390
7	180	(f) Sierra spitzer	.311	3.075	42.0	3031	2533	44,220
8	180	(g) Norma soft-point round-nose	.311	2.980	44.5	4064	2569	43,680
9	215	(h) Remington soft-point	.3105	3.075	49.5	4350	2432	44,630
10	216	(i) Norma soft-point round-nose	.311	3.075	49.0	4350	2404	43,400
11	216	(i) Norma soft-point round-nose	.311	3.075	43.5	4320	2360	44,300
12	216	(i) Norma soft-point round-nose	.311	3.075	43.5	4320	2360	47,610
13	216	(i) Norma soft-point round-nose	.311	3.075	43.5	4320	2295	44,010
14	216	(i) Norma soft-point round-nose	.311	3.075	43.5	4320	2284	43,060
15	174	Ball Mark VII (D.L. 45-50)				Cordite	2433	43,060
16	215	Factory					2185	45,080

Remarks: Instrumental velocities taken at 20 ft. from the muzzle of the gun. Range temperature varied from 70° to 74° F.; relative humidity varied from 62% to 77%. All loads were tested in a British Government pressure barrel, .26" length, .3146" groove diameter, .303" bore diameter, 5 grooves, left-hand twist, 1 turn in 10". With the exception of Loads 12 and 14, all loads were made up with Remington cases and Winchester 120 primers. Loads 12 and 14 were made up with Norma cases and Winchester 120 primers.

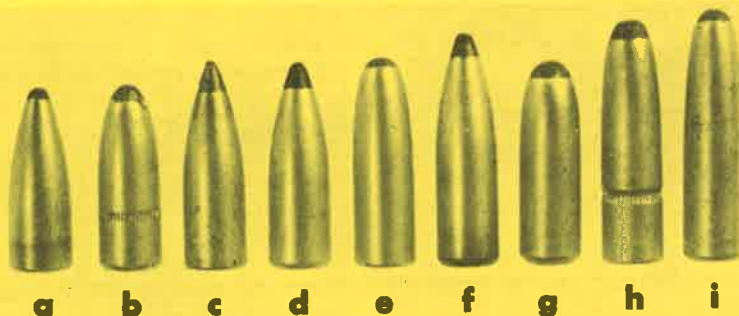

Bullets used in .303 British loads: (a) 130-gr. Norma soft-point pointed; (b) 150-gr. Hornady round-nose; (c) 150-gr. Speer spitzer soft-point; (d) 150-gr. Sierra spitzer; (e) 180-gr. Speer round-nose soft-point; (f) 180-gr. Sierra spitzer; (g) 180-gr. Norma soft-point round-nose; (h) 215-gr. Remington soft-point; (i) 216-gr. Norma soft-point round-nose



1 Lay pattern near base of 26" piece so that bottom of hook, where stock will rest, will be 5¼" from bottom. Draw around pattern to form first hook, then raise it to next place above and draw next hook, etc. Top design may be drawn free-hand or with French curve. Curve must reach end of board so that both sides retain original length. Note that by turning right side end-for-end, the bottom of barrel hook will be some 7½" from the bottom

2 The 2 sides are marked 'S' for stock and 'B' for barrel. With 3 cuts both come out requiring edge sanding only. The pattern may be extended on a longer board to increase number of hooks: 26", 3 hooks; 32", 4 hooks; 38", 5 hooks. Add 6" for each additional space. Shaded area above the 'S' indicates an optional cut for very heavy rifles. For the initial cut follow the line on 'B' side to have both sides come out evenly

HERE is a simple gun rack costing not more than \$1 which with jigsaw and 1¼" sanding drum can be built in 1 hour, or not longer than 2 hours using hand jigsaw and sandpaper.

Materials needed are 1 plank 1"x8"x53" (actually 7/8"x7½"x53"), 12 screws, stain (if desired), and wax.

Cut the 53" board into 2 pieces, with one measuring 26" for the sides; the other 27" to furnish material for the 3 braces.

To prepare the design, take a piece of thin paper and trace over the colored hook pattern. The tracing is then transferred to stiff cardboard using carbon paper and pencil. Cut the pattern out of the cardboard so that it can be used over and over again. Note that a single cut provides both sides of the rack. The hook curve is the same for both sides. However, certain measurements do differ, because to lie horizontal, the barrels must rest about 2" higher than the stocks. Thus the top designs are not the same size.

Check your rifles to determine space needed between rack sides. My 20-power scope required almost 25", so I cut the braces 27" long. I ripped the remaining piece of 8" board into three 2"-wide braces which when dressed were set into the back of the sides.

I recommend counter-sunk 1¼" screws on brace ends to fasten them in their notches. A final sanding completes the woodwork; staining or waxing may follow. Be sure to place the low or stock side to the left when assembling—if reversed the rifle bolts will be to the wall.

Felt strips glued into barrel slots are a refinement. The rack may be decorated with molding cuts, shield designs in the braces, or by carving.

3 The 2 sides after sawing. Three-cornered pieces at top and bottom are waste



Build in one hour . . .

AN ATTRACTIVE GUN RACK

By George Crossette

4 Side pieces are superimposed to demonstrate different levels necessary to make guns lie level. Notches for inserting braces have been indicated

5 This is the rack after it is assembled, stained, and waxed—1 hour working time after first cut

