

The Birth of Art: Paleolithic and Neolithic Art



CHAPTER 1

Map of Prehistoric Europe



Art Before History....

- The era of prehistory dates from 2,000,000 BCE to 3500 BCE
 - Paleolithic era begins with stone tools ca. 2,000,000 years ago.
 - Upper Paleolithic yields the first artworks ca. 40,000 – 9,000 BCE



ART OF THE PALEOLITHIC ERA



The Paleolithic World

- The earliest artworks date to the time in which fully modern humans first enter Europe.
- Life of hunting and gathering, uncertain food supplies, and high mortality. Technology of stone tools; art supplies limited to what nature could supply.
- Works are either portable or created on cave walls that served as dwellings and perhaps religious sites.



The Armless Lady (L) and The Nun (R) from Balzi Rossessi, 6.7 cm high.

*“Venus” of Fels Cave,
currently the world’s oldest
known artwork
ca. 40,000 – 35,000 BCE*



***WOMAN OF
WILLENDORF,
LIMESTONE.***

**CA. 28,000 – 25,000
BCE.**





Woman of Willendorf



“Venus” of Laussel, 1.5 foot high relief.



What areas of the body are emphasized or exaggerated?

What could the content of such a work be?

Is this a celebration of fertility? Or an abundant food source?

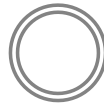

***HUMAN WITH FELINE
HEAD, FROM GERMANY.
IVORY. CA. 30,000 –
28,000 BCE.***



Paleolithic Cave Paintings



Modern visitors in a replica of the Altamira Caves in Spain that opened to tourists in 2001. Altamira was the first of 200 caves discovered in the late 19th and 20th centuries.



***Wounded Bison.* Altamira Cave, Spain. ca. 15,000–10,000 BCE.**



Modern "Aurochs" created through rebreeding



European Bison (Wisent)



Aurochs and horses, Lascaux, France.



Bison (Wisent), Altamira, Spain.



- ***Spotted Horses and Negative Hand Prints, Cave at Pech-Merle, 16,000 BCE (Bison) and 15,000 BCE (Handprints).***

How were cave paintings created?



- Prep work: scaffolding built, stone lamps brought in, pigments and tools created.
- Wall scraped to lighten background.
- Pigments used to both draw and paint on wall.
 - Charcoal
 - Ochre (a type of iron oxide)
 - Mixed with water, spit, blood, or egg
 - Applied with brushes, hands, or blow pipes.

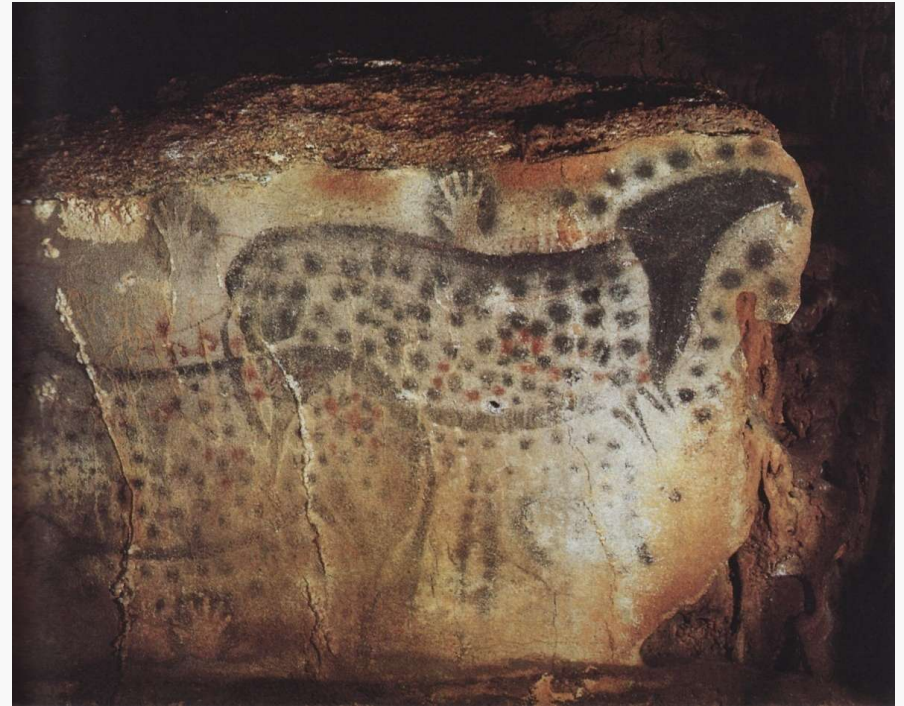

Who do you think created art in the Stone Age?

Hall of Bulls, Lascaux Caves. Ca. 15,000 – 13,000 BCE.

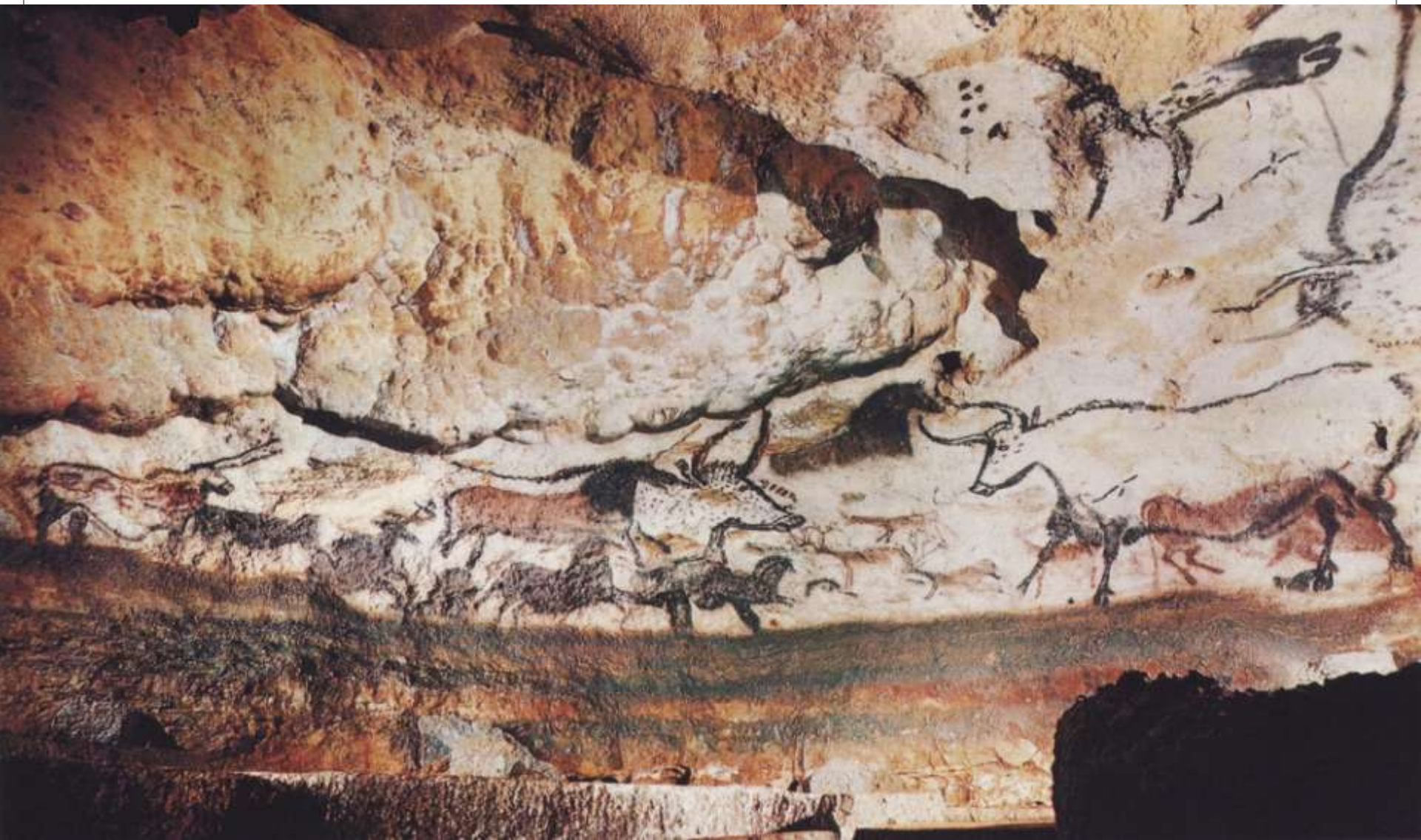

Schematic plan of Lascaux Cave system (based on a diagram by the Service de l'Architecture, Paris).

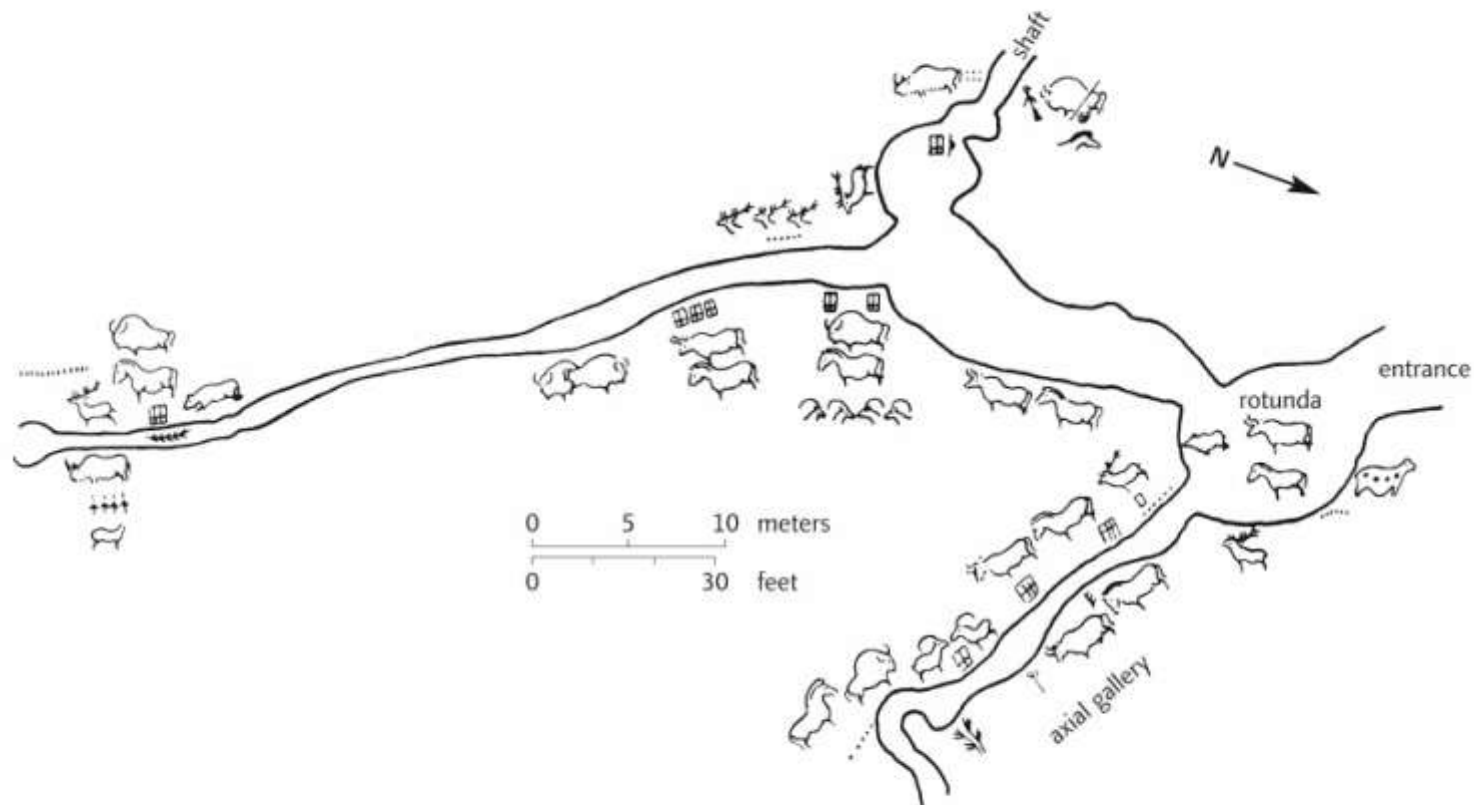

What was the function of the imagery in Paleolithic Caves?

- Theories include:

- Mere decoration?
Probably not
- Religious/magical functions that allowed for ease of hunting.
- Religious/magical functions that increased fertility.
- Caves served as a place of worship



Bison from the Chauvet Cave.

What was the function of the imagery in Paleolithic Caves?



- These are **THEORIES** and current scholarship does not know definitely what the original function OR content was.



Bison from the Chauvet Cave.

The Lascaux Cave: A Virtual Tour



[HTTP://WWW.LASCAUX.CULTURE.FR/?LNG=
EN#/EN/02_00.XML](http://www.lascaux.culture.fr/?LNG=EN#/EN/02_00.XML)

ART OF THE NEOLITHIC ERA: 8,000 – 2300 BCE***

- ***DIFFERENT SOCIETIES ENTER THE NEOLITHIC AT DIFFERENT TIMES.



The Neolithic World



- The end of the Ice Age allowed for a new way of life based on living in settled villages and farming.
- Secure food supplies led some people to acquire skills such as
 - Weaving
 - Potting
 - Engineering
- Allows for new media in art including plaster, ceramic, and architecture. Larger works abound.



Reconstruction of a Celtic or Northern Italian village in the Neolithic era.

The Neolithic World



- The end of the Ice Age allowed for a new way of life based on living in settled villages and farming.
- Secure food supplies led some people to acquire skills such as
 - Weaving
 - Potting
 - Engineering
- Allows for new media in art including plaster, ceramic, and architecture. Larger works abound.



Fragment of cloth from a Neolithic settlement in Fayum, Egypt, ca. 5000 BCE.

The Neolithic World



- The end of the Ice Age allowed for a new way of life based on living in settled villages and farming.
- Secure food supplies led some people to acquire skills such as
 - Weaving
 - Potting
 - Engineering
- Allows for new media in art including plaster, ceramic, and architecture. Larger works abound.



Baked clay (terracotta or ceramic), painted. Ca. 5000 BCE, modern Iran.

The Neolithic World



- The end of the Ice Age allowed for a new way of life based on living in settled villages and farming.
- Secure food supplies led some people to acquire skills such as
 - Weaving
 - Potting
 - Engineering
- Allows for new media in art including plaster, ceramic, and architecture. Larger works abound.



Neolithic village at Skara Brae, 8 surviving dwellings linked together by low passages. Ca. 3200-2200, Orkney Islands.

The Neolithic World



- The end of the Ice Age allowed for a new way of life based on living in settled villages and farming.
- Secure food supplies led some people to acquire skills such as
 - Weaving
 - Potting
 - Engineering
- Allows for new media in art including plaster, ceramic, and architecture. Larger works abound.



Two Headed Bust from Ain Ghazal, Jordan. Plaster and bitumen, ca. 6500 BCE. 35 inches tall.

Female figure (left) and Male figure (right), from Cernavoda, Romania.
Ceramic. ca. 3500 BCE





Neolithic Architecture



***GREAT STONE TOWER
BUILT INTO THE WALLS
OF JERICHO, STONE (NO
MORTAR),
CA. 8000-7000 BCE.***



STONEHENGE,
ENGLAND,
SARSEN AND
BLUESTONES. CA.
2550- 1600 BCE.

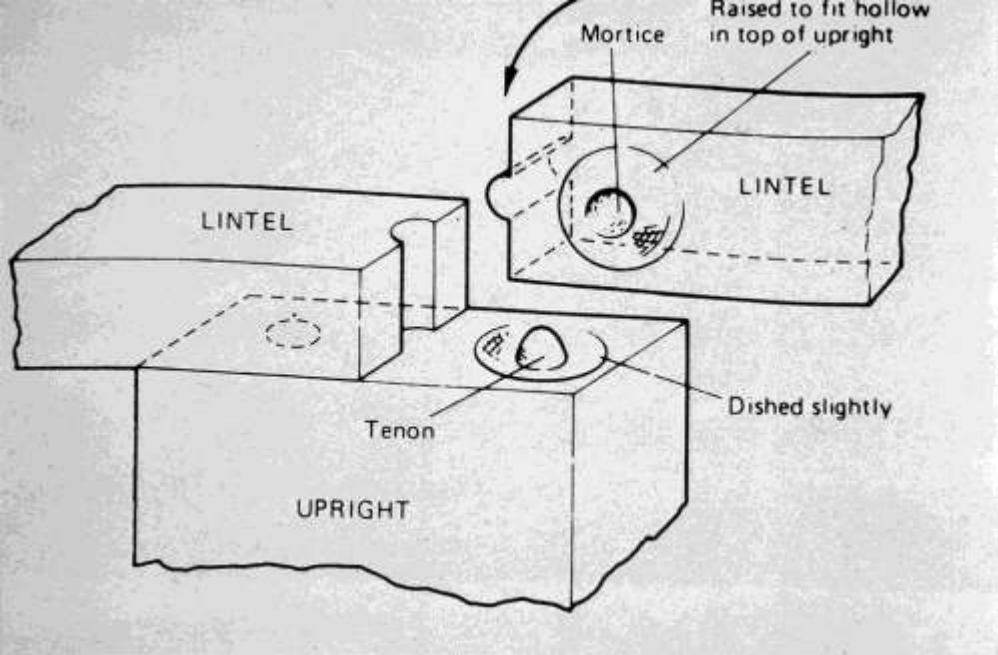

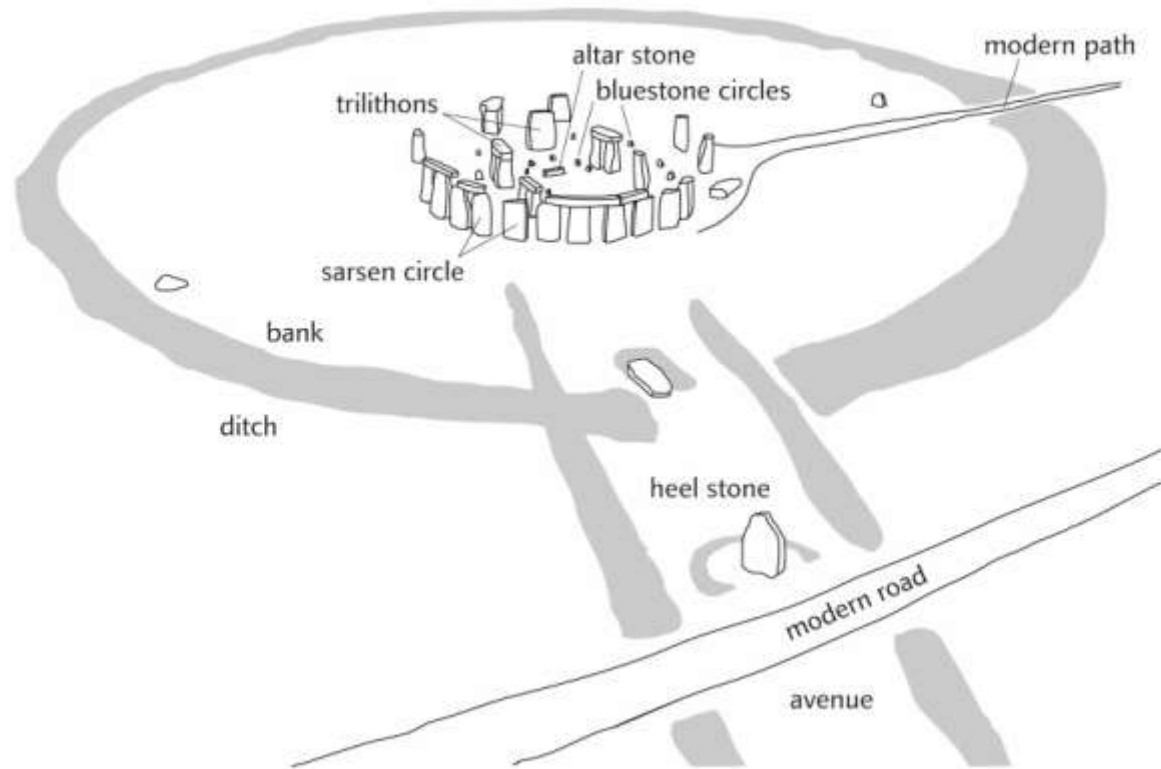

Elongated earth platforms were built to define an “avenue” oriented to the northeast and leading to a massive, 35 ton, 16-foot high, pointed stone monument known as the “Heel Stone” (this is made of sarsen, a grey sandstone transported some 23 miles from a quarry to the Stonehenge site). From the center point of the large circle, a person looking out the “avenue” would see the sun rise over the “Heel Stone” on the day of the summer solstice.

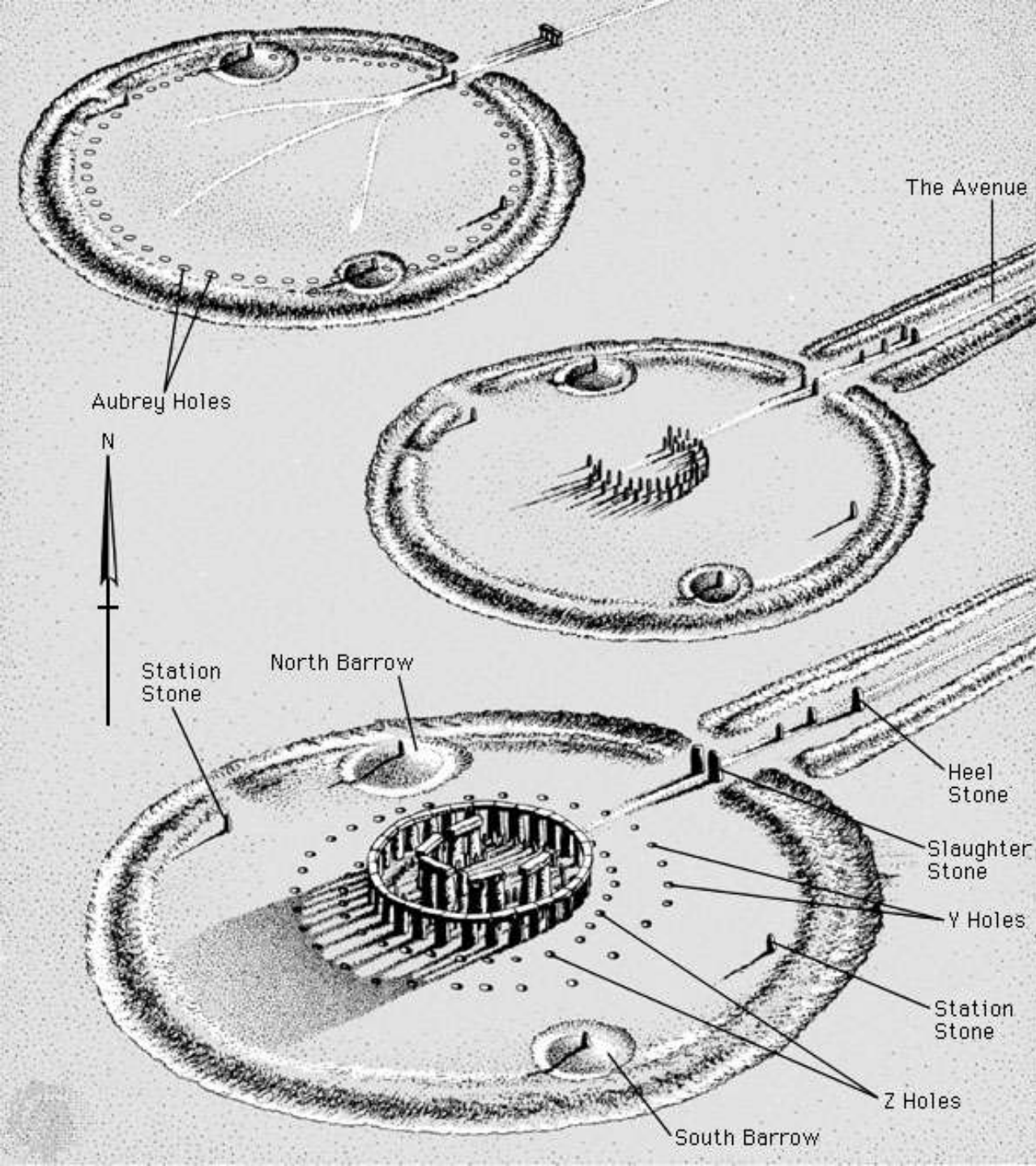

<http://www.stonehenge.co.uk/about.php>

Learning Objectives for Chapter 1



- Understand the origins of art in terms of time period, human development and human activity.
- Classify types of Prehistoric art, their respective media, and techniques.
- Describe the role of animal figures in Paleolithic art.
- Illustrate differences between the Paleolithic and Neolithic art as a result of social and environmental changes.
- Explain the purposes and techniques of monumental architecture during the Neolithic era.