

Cottage Life

The Cottage Life Bunkie

Full plans for a compact
guest cabin, complete
with an adult-sized loft

By WAYNE LENNOX



The Cottage Life Bunkie

By WAYNE LENNOX



INSTRUCTIONS

INTRODUCTION	3
FLOOR	3
SIDE WALLS	3
REAR WALL	4
FRONT WALL	4
PORCH	5
LOFT	6
RAFTERS AND GABLE ENDS.....	6
ROOF	7
LOFT LADDER	7
WINDOWS	8
DOOR	8
TRIM AND FINISHING	9

MATERIALS LISTS

PARTS LIST	6
SHOPPING LIST	9

PLANS

FLOOR	10
SIDE WALLS	11
REAR WALL	12
FRONT WALL AND PORCH ...	13
ROOF AND LOFT	15
LOFT DETAILS	16
LOFT LADDER	17

Cottage Life

Project Editor Allan Britnell
Project Art Director Gary Davidson
Plans Illustrations Len Churchill

Cottage Life Magazine
Editor Penny Caldwell
Senior Editor Martin Zibauer
Art Director Kim Zagar

You'll find more great cottage projects you can build in *Cottage Life* magazine or at cottagelife.com.

Subscription enquiries,
phone 1-800-465-6183 (Canada and U.S.);
Toronto (905) 946-0406.

Cottage Life Magazine
54 St. Patrick St., Toronto ON M5T 1V1

Copyright © 2007 by Cottage Life. All rights reserved. Reproduction of any article, photograph, or artwork, for other than personal use, in whole or in part, without written permission of the publisher is strictly forbidden.

BUNKIE PHOTO BY LEN CHURCHILL

One

of the nicest things about a cottage is that it becomes a place for friends and family to gather and share memories. But the cherished kind of memory probably doesn't include the sound of Uncle Bob's snoring, or having to step over half a dozen nieces and nephews on your way to a midnight snack. With a bunkie, you can invite overnight guests and still have some privacy at bedtime.

And the Cottage Life Bunkie not only makes an ideal guest cabin for cottage overflow, it also doubles as a quiet retreat for those days when even two's a crowd (see "Layout Options For Main Floor," p. 4).

When we designed this structure, we envisioned it as suitable accommodation for a couple of adults and three to four kids. A futon on the main level would work well for a bed for the big folks, while cots or an inflatable bed in the loft would be suitable for the little ones. (Since a queen-size mattress will fit, a couple of adults can also sleep comfortably in the loft).

The *Ontario Building Code (OBC)* requires a building permit for any structure with floor space greater than 10 square metres (108 sq. ft.). This bunkie was designed with that stricture in mind: At 8' by 13'6", it is exactly 108 sq. ft. and therefore, in most jurisdictions, does not need that particular documentation. But check first: Some municipalities require permits for anything over 100 sq. ft. Cottagers in those areas could modify the plans – say, by reducing the length to 12'6" – to fit the more restrictive rules. Even if a building permit is not required, you must still check with your local municipality and comply with zoning bylaws (such as lot line and shoreline setbacks).

This is a big project, but not a very complex one. In fact, if you built the *Cottage Life* outhouse ("The Perfect Privy," Aug. '99) – as many readers have – or the treehouse ("High Society," Apr./May '05), you will find this to be no more challenging.

FLOOR

Footings (six in all) will need to be in place before construction can begin.

I am partial to a double rim joist at the base of structures like this because of its greater strength, especially at interlocking corners. And I like pressure-treated (PT) lumber for any part of a structure close to

The Cottage Life Bunkie

the ground – although, since the floor frame does not, in fact, touch the ground, you could use ordinary lumber.

1. With the parts list (p. 6) and Figures 1 and 2 to guide you, cut all pieces for the floor frame to length (wear a dust mask when you cut PT lumber) and treat the cut ends. Lay out the joist locations – 16" on centre – on the inner rim joists. Note that the measurement to the centre of the first joist from the end must take into account the 3" thickness of the double rim). Leave a ¾" space between the two laminated

4. Two-and-a-half sheets of 5/8" tongue-and-groove plywood are required to cover the floor for the dwelling part of the building. Square up the floor – diagonals must be equal – and screw the plywood to the floor frame.

5. Level the floor frame, if required.

SIDE WALLS

1. Cut the side wall pieces to length. Note that the window headers consist of two 2 x 6s laminated together with a piece of ½" plywood between as a spacer. Also, the



Designer and builder Wayne Lennox first constructed the Cottage Life Bunkie on site at the Spring Cottage Life Show. Here, he's prepping the double rim-joist floor framing.

bunkie joists that sit at the 10' mark and the first deck joist. This gap allows rain and melt-water to drain between the boards.

2. Nail or screw the inner frame together. (The 3½" deck screws in the hardware list [p. 9] are needed only if you are screwing the frame together.) Remember to keep joist crowns up; the crown is the convex edge of a board when viewed from the end. Nail or screw the outer rim joists to the inner frame.

3. Cut bridging pieces to length and install between floor joists.

Tip: When you measure for the bridging, take your measurements between the joists where they are secured to the rim, not in the middle. After installing two or three bridging pieces, check the cumulative measurement of bridging and joists and compare with the measure at the rim joist to be sure you're not bending the joists out of line. Adjust the next piece you install to compensate, if needed.

6 x 6 by 43½" side headers are mitred 45° at the porch end and notched at the other end (Figures 14 and 16). Drill two ½" holes – preferably with a Forstner bit – in the face of each side header, as in Figure 14. Drill clearance holes. Cut eight ½" plugs and put them aside for now. (A plug cutter is an inexpensive accessory available at any lumber or hardware store. Use it to make your own matching plugs from castoffs. Of course, there are also commercially available plastic plugs.)

2. Lay out the stud locations on the bottom and top plates as in Figure 3 (make sure that your layout is consistent with the rough opening for your windows). Note also that the centres are not all 16". When siding, start from the porch end. The edge of the second 4 x 8 sheet will line up with the middle of a stud marked with an X. The remaining piece is 2' wide (a 4 x 8 sheet ripped in half provides the 2' pieces).

The Cottage Life Bunkie

3. Nail or screw the wall frame together on the ground, adding the double top plate last (lay out the location of the rafters on the double top plate first, starting from the porch end). Do not add the 6 x 6 side headers yet.
4. Cut the 2 x 4 blocking to length and nail between the studs.
5. We selected Canoxel 4 x 8 pre-finished panels for this project for a number of reasons: sub-sheathing is unnecessary, siding time is reduced, and they look good. On the downside, there is a limited colour selection and the finish is only under warranty for five years, so repainting could be necessary after that. Cut five sheets to a length of 93½" (good-side down to avoid chipping on that side). Rip one piece in half, lengthways.
6. Lay the sheets on the wall so that the edges meet the top plate. Transfer the location of the rafters on the edges of the sheathing. Remove the siding and cut 1½" by 5¾" notches where marked (see Figure 14). The siding panels will sit proud of the top plate. These notches allow the rafters to sit tight against the plates and also let the siding butt against the bottom of the roof boards thereby sealing the building from drafts. You can be a little generous with the cuts as small gaps can be filled with caulking.
7. Lay the siding pieces back on the walls, making sure that the bottom edges are 3" below the bottom plates (this lip can later be nailed to the rim joist). Square up the frame and nail the siding to the wall using 2" galvanized ardox nails, spaced about 8" apart.



You'll need a couple of helpers to lift the walls in place. Note the notches cut into the top of the siding panels. These allow the bird's mouth rafters to fit snugly against the top plate.

8. Find two helpers. Stand each wall up in turn, being careful not to damage the bottom edge of the panels. Line up the bottom plates with the floor's edges. Screw or nail the bottom plates to the floor.

Tip: Don't drive the nails home yet in case you need to move the wall. Nail temporary braces from the end studs to the rim joist. The walls should tip out slightly at the top.
9. Add a 1 x 3 temporary, vertical brace at the porch end (see photo, p. 5), from the rim joist to the end of each top plate. Insert the 6 x 6 side headers into the space created when you framed the side walls. Screw to the top plates and to the 2 x 4 studs. This is also a helper-assisted procedure!

10. Drill a 1"-dia. by 2"-deep hole down through the top plate and into the side header where indicated in Figure 16. Drill a 5/16" clearance hole all the way through.
11. If you have a reciprocating saw, cut out the window openings from the inside. If you only have a jig saw, drill holes through the paneling at each corner, go outside, draw lines between the outside radii of the holes, and follow the lines to cut out the window openings.
12. Do not add the 6 x 6 posts yet.

REAR WALL

1. Cut all the pieces and assemble the rear wall as shown in Figures 8 and 9. Since there are no window openings, cladding is simply a matter of nailing the two 4' by 89" panels to the assembled wall. Make sure that the top edges of the panels are lined up with the bottom edge of the top plate, i.e., between the two plates.
2. With a helper, lift the rear wall assembly into place. Nail or screw the bottom plate to the floor. Nail or screw the corners together. Nail the 3½" overhangs to the side wall end studs. Nail the bottom edge of each panel to the rim joists.

FRONT WALL

1. Cut all front wall pieces to length (see Figure 10). The header over the window consists of two pieces of 2 x 4 laminated together. Since the front wall is not a load-bearing wall, the header over the door

Layout options for main floor

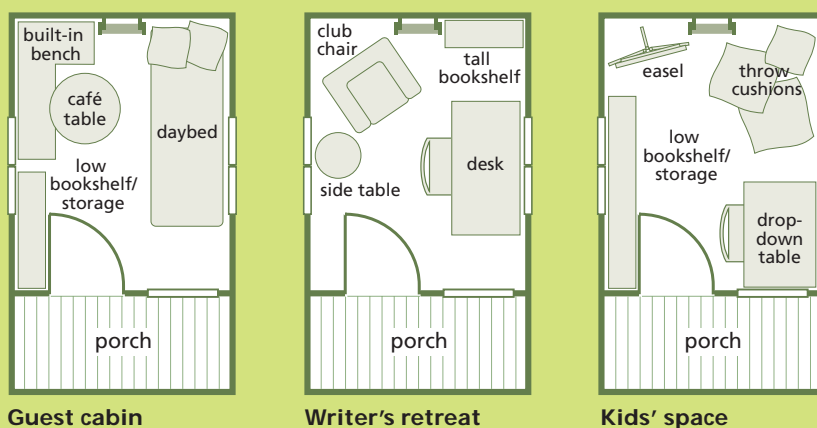

The Cottage Life Bunkie

consists of a single 2 x 4 on the flat to provide the correct dimension for the entrance door rough opening.

2. Nail or screw the frame together. Note that the piece in the bottom plate, where the door is located, will be removed after the assembled wall is in place.
3. Trim two sheets of siding to 91".
4. Lay one panel on the wall over the door opening, noting that the top edge should be flush to the top of the double top plate,

side wall end studs. (If the floor is level and the walls are square then, when assembled, the walls should be plumb.)

8. Before you can cover the porch ceiling, you will need to scab a 2 x 4 nailer to the top of the front wall double top plate to act as a nailing edge (see Figure 11). It should extend about halfway over the leading edge of the double top plate.
9. With all four walls in place, drive the bottom plate nails home, cut out the openings



The bunkie loft extends out over the porch. For an extra 3½' of floorspace on the ground level you could modify the plans, eliminating the porch and moving the front wall forward

and the left side should be 3½" past the end stud (this lip will be nailed to the side-wall end stud). Square everything up and tack the sheet in place. Have a helper lift the upper end of the wall up off the floor, high enough so that you can trace the opening for the door. Lay the wall back down, remove the sheet and cut out the opening for the door. While you're at it, cut out notches for the 6 x 6 side header and for the rim joists (include the thickness of the plywood floor in this calculation).

5. Lay the panel back down and nail it to the frame.
6. Lay the other sheet on the frame and nail it down.
7. Remove the two braces from the side walls and, with a helper, lift the front wall into place. Nail or screw the bottom plate to the floor. Nail or screw the corners together. Nail the 3½" overhangs to the

for the front window and door, and then cut out the sill space for the door opening.

PORCH

I chose cedar for the front porch – despite its rather steep cost – chiefly because it is hard to find 6 x 6 pine (my preferred material). PT is a lot cheaper but far less attractive than cedar, unless painted or stained.

1. Cut the 5/4 x 6 deck boards to length – allowing for 1" of overhang at the front – and nail or screw to the joists. A clearance hole may be needed at the board ends to prevent splitting. Begin in the centre and work your way out evenly to both sides, leaving a 3/8" gap between the boards. The last two boards may have to be ripped – make sure to leave a 1" overhang as well. If you were careful, each end board should be the same width.
2. Cut the two 6 x 6 porch posts and the front header to length; the header is mitred

at both ends. (Mitring the 6 x 6 is a bit of challenge if you do not own a 12" compound sliding mitre saw: Mark your cut line, then take passes with a circular saw from either side. There will likely still be a sliver of wood in the middle that you'll need to clear with a handsaw.) Drill two 1/2" holes, 3/4" deep in the end faces, as in Figure 14.

3. Stand the end posts in place. Lag the 6 x 6 by 43½" side headers to the tops of the posts with the 8" lag bolts. Plumb the posts and toenail to the floor, keeping the nails or screws below the line of the trim (about 2"). For added strength, you can also drive a few screws up into the post end from the underside of the deck boards (though it's a little tricky, considering that the piers may be in the way!)

4. Lift the 6 x 6 by 8' front header into place. Attach it to the side headers with outdoor glue and the #12 x 3½" screws. Plug the holes (glue the plugs in place and trim them after the glue dries).

5. Add the 2 x 6 top plate and screw or nail it down to the front header. Drill a 1" hole about 2" deep down through the 2 x 6 into the top of each end of the 8' header. Drill a 5/16" clearance hole as in Figure 16. Lag the 8' header to the end posts. Also screw the side wall 2 x 4 top plate to the header using #8 x 3" screws with clearance holes to minimize splitting.

6. Screw or nail the 2 x 4 nailing edge to the 2 x 6, as in Figure 11.

7. According to the *IBC*, a deck does not need a railing if it's less than 2' above grade. For decks higher than that, the railing must be no less than 35" high. If the deck is higher than 5'11" above grade, then the railing must be 42" high. If you are installing the optional railing assemblies, start by notching the newel posts, as in Figure 15. Determine where the newel posts will be situated and mark 1¾" by 3½" rectangles on the deck boards. Remove the marked boards and cut out the rectangles with a jigsaw. Replace the boards, fit the newel posts into the holes, and clamp in place. Make sure that, once installed, the railing assembly will fit tightly against the newel and corner posts. Drill two 3/8" holes through the rim joists and each newel post. Insert the 3/8" x 6" carriage bolts, add the washers and nuts, and tighten.

8. Cut pickets to length (36" or 38", see below) and router all four edges with a

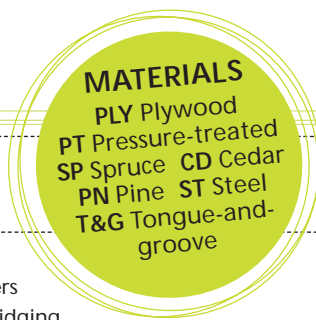

The Cottage Life Bunkie

PARTS LIST

USE	MATERIAL	TYPE
FLOOR		
Joists and end stringers	16 at 2 x 6 by 8'	PT
Stringers and solid bridging	5 at 2 x 6 by 14'	PT
Bunkie floor	2.5 at 5/8" x 4' x 8' T&G	PLY
SIDE WALLS		
Posts and headers	2 at 6 x 6 by 12'	CD
Top and bottom plates and blocking	8 at 2 x 4 by 10'	SP
Studs (2 per 14' piece)	16 at 2 x 4 by 14'	SP
Bracing	4 at 1 x 3 by 8'	SP
Window headers (doubled)	2 at 2 x 6 by 8'	SP
Canoxel Shiplap Panel	5 at 7/16" x 4 x 8	PLY
FRONT AND REAR WALLS		
Studs (2 per 14' length)	9 at 2 x 4 by 14'	SP
Top and bottom plates, wall blocking, and nailing edge	10 at 2 x 4 by 8'	SP
Canoxel Shiplap Panel	6 at 7/16" x 4 x 8	PLY
PORCH/RAILINGS		
Header	1 at 6 x 6 by 8'	CD
Newel posts	1 at 4 x 4 by 8'	CD
Hand rails	1 at 2 x 4 by 14'	CD
Hand rails	1 at 2 x 4 by 8'	CD
Pickets	26 at 2 x 2 by 36"	CD
Corner brackets	1 at 2 x 4 by 12'	CD
Curved pieces	1 at 2 x 6 by 6'	CD
Top plate	1 at 2 x 6 by 8'	SP
2 x 4 nailing edge	1 at 2 x 4 by 8'	SP
Porch floor	70 lin.ft. 5/4 x 6	CD
Porch ceiling	70 lin.ft. 1 x 6 T&G	PN
Trim (ripped to 1 x 2 and routed)	1 at 1 x 6 by 8'	CD
LOFT		
Joists and solid bridging	8 at 2 x 6 by 8'	SP
Flooring	150 lin.ft. 1 x 6 T&G	PN
Gate	1 at 2 x 4 by 8'	PN
Loft railings	2 at 2 x 4 by 12'	PN
Panels in gate and railings	2 at 1 x 4 by 8'	PN
Railing shoe and top rail	2 at 1 x 2 by 8'	PN
ROOF AND GABLE ENDS		
Rafters, 22 with bird's mouth, 4 without	26 at 2 x 4 by 8'	SP
Gable framing	4 at 2 x 4 by 10'	SP
Roof boards	400 lin.ft. 1 x 10	PN
VicWestSuper Vic Profile	14 at 30" x 93"	ST
Ridge cap	2 at 10'	ST
LADDER		
Stringers and ladder brackets	2 at 2 x 4 by 12'	PN
Rungs	1 at 2 x 4 by 14'	PN
Railings	2 at 1 x 3 by 10'	PN
TRIM		
Fascia	4 at 1 x 6 by 16'	PN
Corner trim	8 at 1 x 6 by 8'	PN
Horizontal lintel on rear wall	1 at 1 x 6 by 10'	PN
Gable end trim	4 at 1 x 2 by 8'	PN

roundover bit. Screw the pickets to the handrails. I suggest covering the screws with 3/8"-plugs on the top handrail for a more attractive finish. Drill pocket holes (with a pocket-hole jig) slightly angled out on the underside of the handrail ends and secure them to the posts. Router the handrail and shoe rail edges, top and bottom, with a roundover bit. To keep the pickets from turning, glue them in place.

9. Cut out and assemble the brackets (see Figure 13). Locate and attach to the posts and headers with eight #8 x 2" screws per bracket. If you've plugged all of your holes so far, then don't neglect to do so now (this requires 3/8" plugs).

LOFT

The loft joists are located on the inside of the roof rafters, as in Figure 17. The rafters will be screwed or nailed to the joist ends later.

1. Cut the loft joists to length and trim the corners as required. Set the joists in place and toenail to the top plates.

2. Cut bridging pieces to length and install between the loft joists, as in the floor construction.

The loft floor, as well as the railing and gate assembly, can be installed once the rafters have been installed (see instruction on p. 7).

3. Next, you need to finish off the ceiling of the porch area with pine tongue-and-groove. Cut the boards to length and attach to the two nailing boards and to the underside of the loft joists in the porch ceiling. You will have to add trim around the inside perimeter to hide the gap left over the headers. (The trim is not needed on the front wall, but makes for a more finished appearance. Add only after the siding has been installed). This is the same trim that you will use for the foot of each corner and newel post.

RAFTERS AND GABLE ENDS

1. Lay out and cut the rafters as in Figures 6 and 7. Note that 22 have a bird's mouth, while four do not. Now, 53° might seem like a rather arbitrary angle for rafters, and it is. It was born out of the necessity to gain as much room as possible in the loft and from the fact that my mitre saw will cut angles as great as 65°. So, after a number of drawings we determined that 53° would give the most pleasing appearance as well as maximize loft height.

The Cottage Life Bunkie



The rafters meet at a 37° angle at the peak – a rather arbitrary figure chosen for looks and the amount of headroom it gives in the loft.

2. Set opposing rafters in place on the top plates, beginning at the porch end. The first seven sets sit tight to the loft joists (the left-over piece of plywood laid on the loft joists serves as an excellent temporary floor). There is no ridge board in this plan so the rafters will butt up against each other. Screw or nail the rafters together at the peak, toenail to the top plate, and nail or screw to the joist – where applicable.

3. Plumb up the last set of rafters, bracing them from the inside of the back wall. Temporarily nail or screw a couple of 1 x 3s to the rafters to hold them parallel. Check the spacing between the sets and check that the first set is also plumb and that the overall distance is 13'6". Make adjustments as you go.

4. Now you can go back and finish off the loft floor, as well as the railing and gate assembly. For the pine tongue-and-groove floor, start with the groove edge of one 96" piece tight to the rafters. Nail through the tongue diagonally into the joist. Proceed until you reach the other rafter. Cut short pieces to fill between rafters and create a seal between the floor and the roof boards. Nail in place (it is a good idea to add a nailing strip to the rafter face as well).

5. Figure 20 shows details for the loft railing and gate (the view is from the inside of the loft looking towards the rear of the bunkie). If you plan to move a large mattress into the loft, hold off on building this

until the end, after you get the mattress in place. This railing consists of pieces ripped from lengths of 2 x 4 pine (some retail outlets sell 2 x 2s) and 1 x 4 boards. There is a 24" gap for a gate in the middle for entry and egress to the loft via the ladder. The 1 x 2 bottom rail makes it easy to secure the railing assembly neatly to the loft floor. The gate swings into the loft space with two short 1 x 2 pieces acting as stops. A magnetic catch holds the door closed.

6. Frame the gable ends (Figures 9, 18, and 19). It is unusual to use 2 x 4s on their faces in the manner shown in Figure 18 for this instance. The gable end with no window should be framed in the traditional manner.

7. Side the gable ends. One sheet will do for each; however, the sheets are too big to handle, so I suggest doing the layout and cutting on the ground. Keep in mind that you want the siding to extend 1/2" down onto the 6 x 6 header. You can use the off-cuts from the porch end to fill in the back end, and vice versa.

8. With a helper working from the loft, lift the 4'-wide, pre-cut centre piece up into place in the front gable. Tack in place and get your helper to trace the window opening. Bring the piece back down and cut out the window opening. Lift the piece back up into place and nail to the rafters and gable frame. Nail the end pieces into place.

9. You should also nail filler pieces of siding between the rafters that sit on the 6 x 6 side wall headers, bearing in mind that they must be wide enough to meet the top edge of the rafter and extend 1/2" down onto the side-wall headers.

10. You will only be able to add the sub-fascia rafters, at the front and back of the roof, once the roof boards have been nailed in place (Figure 18).

ROOF

1. Starting at the rafter tails and working your way up, nail the roof boards to the rafters, good side down, three nails per rafter. The gable overhang should be 13 1/4" (install long, measure, snap a chalk line, and cut when the boards are already nailed down).

2. Screw the sub-fascia rafters to the roof-board ends.

3. Measure, cut, and nail the eave fascia to the rafter tails (see Figure 18). The two gable end tails need to be perfectly vertical.

4. Now cut the pieces for the gable end fascia. In the middle of two 1 x 6 by 16' boards, make the 37° cut for where they meet at the peak. Temporarily tack them in place to the sub-fascia rafters and trace the line where these meet the eave fascia. Remove and cut off this piece. Nail to the sub-fascia rafter and to the eave fascia.

5. Staple the roofing underlayment to the roof boards, beginning at the bottom.

6. Cut the steel roof panels to length with a metal-cutting blade in your circular saw. Make sure you use a straightedge guide.

7. Install the panels with the cut edge towards the peak, overlapping each panel with the next, by about 1". We used 1 1/2" screws to avoid strapping. (Do not over-tighten as the screw tips will pierce the roof boards. If any do poke into the loft space, file or cut off the tips with a mini-grinder.) Rows of screws should be 2' apart. You will have to overlap the last panel.

8. Install the ridge cap. You'll have to cut one of the ridge cap pieces to length – don't forget to leave extra length to allow the pieces to overlap each other.

LOFT LADDER

1. Cut the two ladder stringers and brackets to length from the 12' lengths of 2 x 4 pine (see Figure 23). The rungs are cut from a 2 x 4 by 14'. Using a jigsaw, round the ends of the stringers and the brackets.

The Cottage Life Bunkie



When not in use, the loft ladder swings up against the back wall of the bunkie. A short length of chain with a brass snap and two quick links secures it in place.

Router and sand the outside and inside perimeters of the stringers and rungs with a roundover bit.

2. Lay out the rung pattern on the stringers (the 9" rise is something of a compromise between a stair riser – about 8" – and a ladder rung – about 11"). (It also makes the last step 9" below the loft floor). Remember that the pattern will be opposing. Cut $\frac{1}{4}$ " by $\frac{1}{2}$ " dados into the stringers to accept the rungs, as in Figure 22.

3. Drill $\frac{3}{8}$ " holes in the ends of the stringers and in the ladder brackets where indicated (Figure 25).

4. Assemble the ladder using #9 x 3" screws and wood glue. (Fill the holes with plugs if you've done so elsewhere.) Make sure construction is square before the glue sets.

5. Cut handrails and handrail brackets to length as in Figures 22 and 23. Round the ends of the handrails and router both inside and outside perimeters.

6. Secure the handrail brackets by glueing and screwing them to the outside of the stringers (with #8 x 2" screws). Glue and screw the handrails to the inside of the brackets (with #8 x $1\frac{1}{4}$ " screws).

7. Set the ladder brackets in place on the inside of the appropriate studs (Figure 9) and drill two $\frac{5}{16}$ " holes through each bracket and stud. Fasten the brackets to the studs with two $\frac{5}{16}$ " x 4" carriage bolts, washers, and nuts (with the nuts on the inside).

8. Secure the ladder to the brackets with the $\frac{3}{8}$ " x 4" carriage bolts, washers, and nuts (again, with the nuts on the inside).

9. Lean the ladder against the wall. Screw a $\frac{3}{8}$ " eye bolt into the ladder stringer and into a rung (a pilot hole is essential). At the same level, drill a $\frac{3}{8}$ " hole through the closest stud (see photo, above). Insert a threaded eye bolt into each hole and add a washer and nut. (If you need to cut the bolt to length, file the end smooth.) Use a quick link to attach one end of the correct length of chain to the eye bolt in the ladder. Use another quick link to attach a snap to the other end of the chain. Snap to the eye bolt in the stud and, *voilà*, the ladder is secured. You may have to play with the chain length until you are satisfied.

10. Unhook the snap and lean the ladder against the loft. Cut two pieces of pine tongue-and-groove board: 1" x 6" by 17". Screw or nail to the top of the brackets (Figure 25). These boards form the first step. (If screwing, it is a good idea to drill clearance holes to minimize the risk of splitting.) The boards should not extend out over the curve of the brackets.

WINDOWS

We used Canadian-made Anderson windows (note that this is a different manufacturer than the Andersen brand). I also opted for pine frames and brick-stop mouldings. In this instance, because of the flat siding product we used, the windows can be installed over the siding. (Generally, windows are installed first and then siding butts up against the frame.)

1. Set the windows in the spaces provided (this is usually a two-person job – one holder, one installer). Shim for plumb and level.

2. Nail or screw into the sill and studs only, through the shims, and into the 2 x 4 frame. Again, $\frac{3}{8}$ " holes and plugs should be used for appearance if using screws.

3. Since the windows I have selected come complete with brick-stop mouldings, these can be nailed into the 2 x 4s as well. (To reduce drafts, you should caulk around these later with a paintable or coloured caulk.)

4. Carefully trim away the shims.

Note: The windows, door, siding, and roofing materials are all special-order materials. Allow 2–3 weeks for delivery.

DOOR

1. If the entrance door you select is prehung (always the better option), then

Cost cutting

To build an exact replica of the bunkie shown here will set you back between \$5,000 and \$6,000 in materials. But most of the budget will be for new, high-end windows and doors. You could easily trim back the project costs by using a second-hand door and windows. Here are some other ways to lower your bunkie budget:

- Clad the walls in aluminum or vinyl siding (you won't need to re-stain or paint it).
- Use pressure-treated lumber instead of cedar for the porch railings.
- Use plywood for the loft floor instead of tongue-and-groove pine.
- Simplify construction (and make a larger main floor) by eliminating the porch and extending the sidewalls to the front of the floor frame.
- Use asphalt shingles instead of steel roofing.

The Cottage Life Bunkie

installation is straightforward. Remove the pins from the hinges and lift the door out of the frame. Sit the door frame in the opening. (Note that you will need to add a strip of $\frac{3}{8}$ " plywood to the underside of the sill to bring it level with the deck boards.) Level the top jamb, shim, and plumb up the hinge-side jamb. (Shims on the hinge side should be situated behind the three

hinges.) Shim and plumb up the strike-plate jamb, keeping it parallel to the hinge-side jamb. (Shim in three places as well, making sure to place one set of shims behind the strike plate.) When you are satisfied, nail in place. Hook the door back into the hinges, add the pins, and check that it operates smoothly.

Tip: For a more secure installation, remove

one factory installed screw – the middle one – from each jamb hinge and substitute a longer one that will pass through the shims and well into the 2 x 4 trimmer.

2. Some pre-hung doors come complete with brick-stop mouldings already installed. If not, you will have to cut and nail the trim to the door jambs.

3. Installing the screen door may require mortising the hinges. (I recently acquired a \$50 mortising jig for my router and it performed exceedingly well.) However, the door from Beyond The Screen Door actually mounts to the brick stop moulding, so I used face-mount screen door spring hinges.

TRIM AND FINISHING

1. Since few places sell cedar trim, you will most likely have to fashion your own. Rip one 2" strip and two 1½" strips from the 1 x 6 by 8'. Add a routed profile of your choice. (Use the same profile for the porch ceiling trim.) Mitre and nail 2" trim around the base of the corner and newel posts. Repeat below corner brackets as in Figure 14 with the 1½" trim.

2. Trim the inside perimeter of the porch ceiling with 1½" trim.

3. Measure and trim the 10' length of 1 x 6 pine, and nail over the sheathing on the rear wall. Centre it more or less on the line that divides the sheathing so you can nail into the framing below and above the top plates. Add a bead of caulk along the top edge as a water barrier. (To harmonize wood types, you could expand your budget and select 1 x 6 cedar for the trim instead of pine.)

4. For the corners of the building, we used 1 x 6 to maintain a balance with the 6 x 6 posts, giving the structure a kind of faux timber-frame style. Consequently, one of the two pieces used for each corner will have to be ripped to 4¾".

5. Where the siding meets the roof boards in the gable ends, trim with 1 x 2.

6. All exterior wood surfaces should be given a protectant finish.

7. Caulk where required (around the windows, door, and where the top of the siding meets the rafters and the roof boards). 🐦

Shopping list

MATERIALS

PRESSURE TREATED LUMBER

- 16 at 2 x 6 by 8'
- 5 at 2 x 6 by 14'

SPRUCE LUMBER

- 6 at 1 x 3 by 8'
- 26 at 2 x 4 by 14'
- 12 at 2 x 4 by 10'
- 40 at 2 x 4 by 8'
- 11 at 2 x 6 by 8'

CEDAR

- 1 at 2 x 6 by 6'
- 2 at 6 x 6 by 12'
- 1 at 6 x 6 by 8'
- 1 at 4 x 4 by 8'
- 1 at 2 x 4 by 14'
- 1 at 2 x 4 by 12'
- 1 at 2 x 4 by 8'
- 2 at 1 x 6 by 8'
- 26 at 2 x 2 by 36"
- 70 lin.ft. $\frac{5}{4}$ x 6" deck boards

PINE LUMBER

- 400 linear feet 1 x 10 rough-sawn pine
- 230 linear feet 1 x 6 T&G flooring
- 4 at 1 x 6 by 16'
- 8 at 1 x 6 by 8'
- 1 at 1 x 6 by 10'
- 4 at 2 x 4 by 12'
- 1 at 2 x 4 by 14'
- 1 at 2 x 4 by 8'
- 2 at 1 x 4 by 8'
- 2 at 1 x 3 by 10'
- 6 at 1 x 2 by 8'

PLYWOOD

- 3 at $\frac{5}{8}$ " x 4' x 8' T&G

LP CANEXEL SHIPLAP PANELS

- 11 at $\frac{7}{16}$ " x 4' x 8'

VICWEST SUPERVIC PROFILE

STEEL ROOFING

- 14 at 30" x 93"
- 2 x 10' steel roofing ridge cap

HARDWARE

- 1 bundle cedar shims (full size)
- 1 container outdoor glue
- 250 #9 x 3½" deck screws
- 250 #8 x 2" deck screws
- 2 at $\frac{3}{8}$ " x 4" carriage bolts, nuts, and washers
- 4 at $\frac{5}{16}$ " x 4" carriage bolts, nuts, and washers
- 2 Anderson model 2N1630 double casement windows
- 1 Anderson model N1624 casement window (RH)
- 1 Anderson model W2430 casement window (RH)
- 1 at 32" x 80" screen door and hardware
- 1 at 32" x 80" prehung pine entrance door and hardware
- 4 at $\frac{3}{8}$ " x 6" carriage bolts, nuts, and washers
- 2 at $\frac{5}{16}$ " x 8" lag bolts and washers
- 2 at $\frac{5}{16}$ " x 6" lag bolts and washers
- 100 #10 x 3½" wood screws
- 20 #12 x 3½" wood screws
- 1' medium link chain
- 2 quick links
- 1 brass snap
- 1 at $\frac{3}{8}$ " x 5" lagged eye bolt
- 1 at $\frac{3}{8}$ " x 5" threaded eye bolt, nut, and washer
- 2 at 2½" butt hinges
- 1 magnetic catch
- 2 lbs. of 2" galvanized nails for Canexel panel
- 1 box of 1½" screws for steel roof
- 1 roll VicWest underlayment
- 1 tube clear silicone caulk
- 2 tubes acrylic caulk (colour matched)
- Foam screened insert for ridgecap

FINAL COST:
about \$5000.00
to \$6000.00



Bring this materials list to your local TIM-BR MART. To find a location near you, click here.

The Cottage Life Bunkie

FLOOR

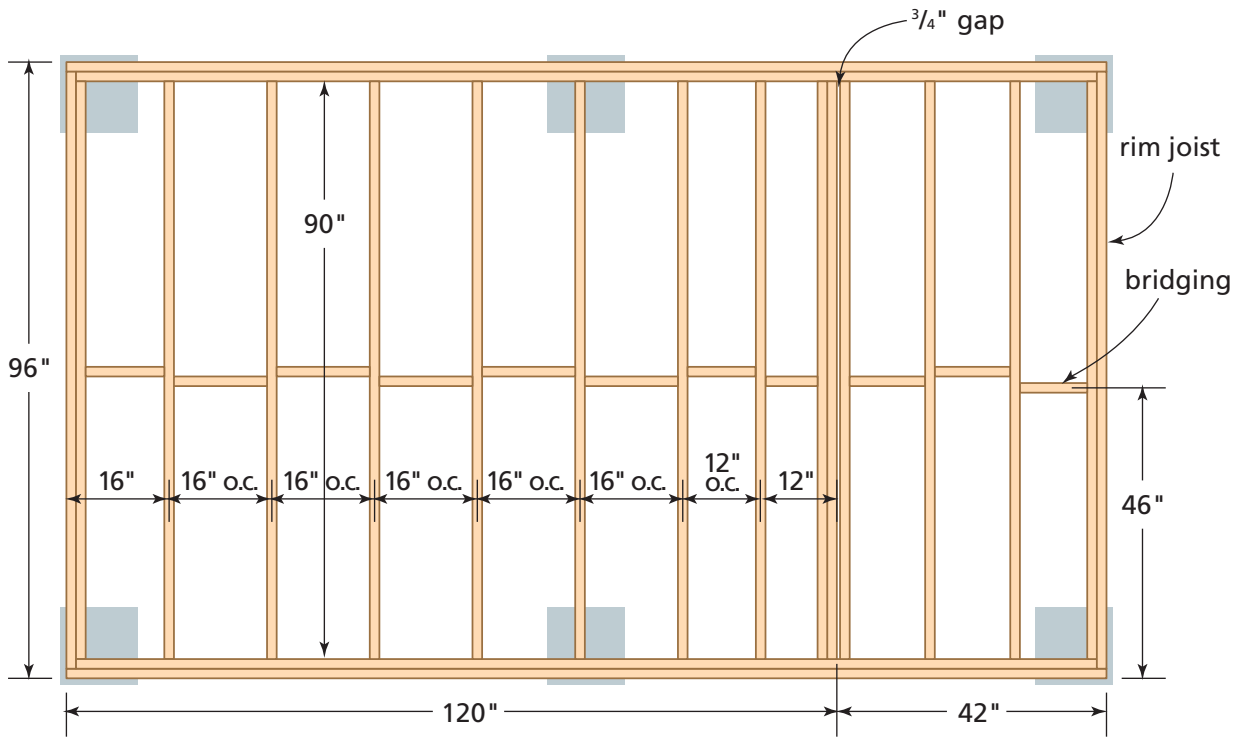

FIG 1: FLOOR

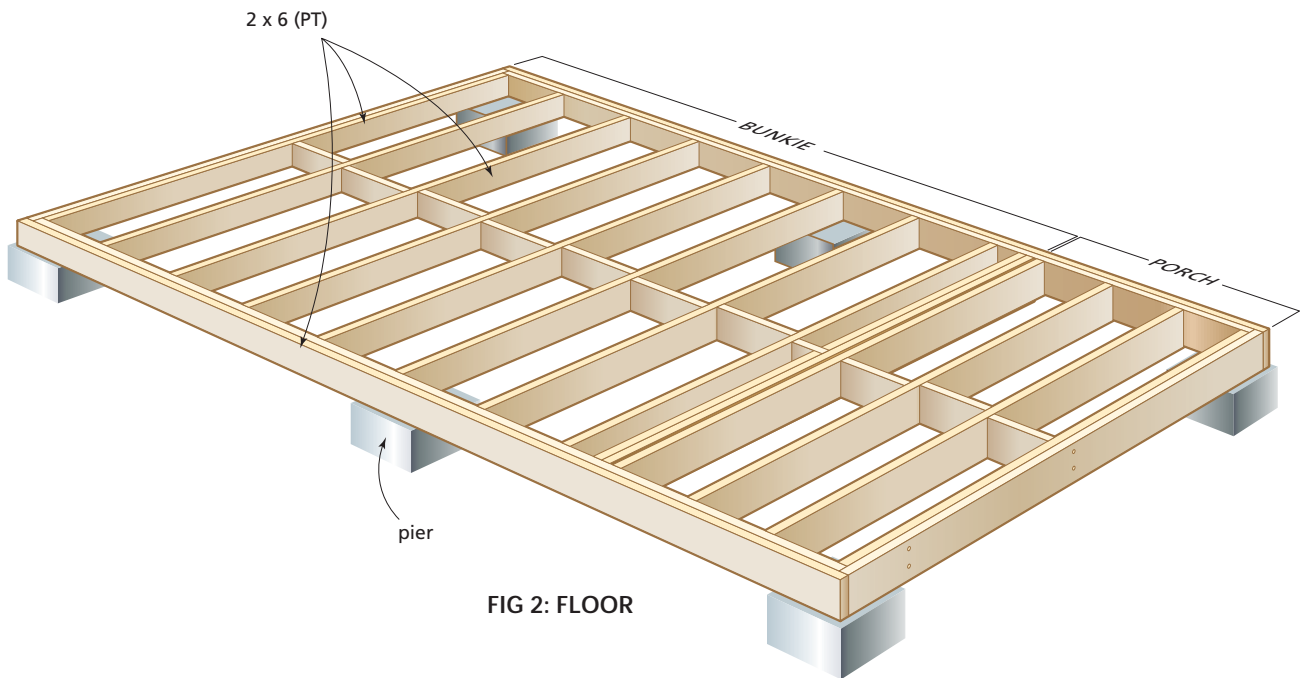

FIG 2: FLOOR

The Cottage Life Bunkie

SIDE WALLS

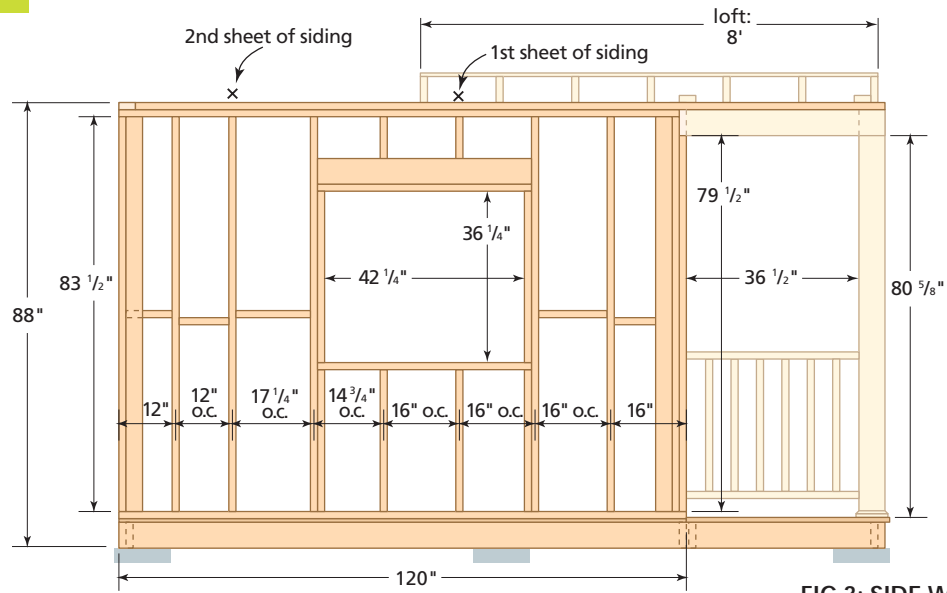

FIG 3: SIDE WALL

FIG 4: CORNER BLOCK DETAIL

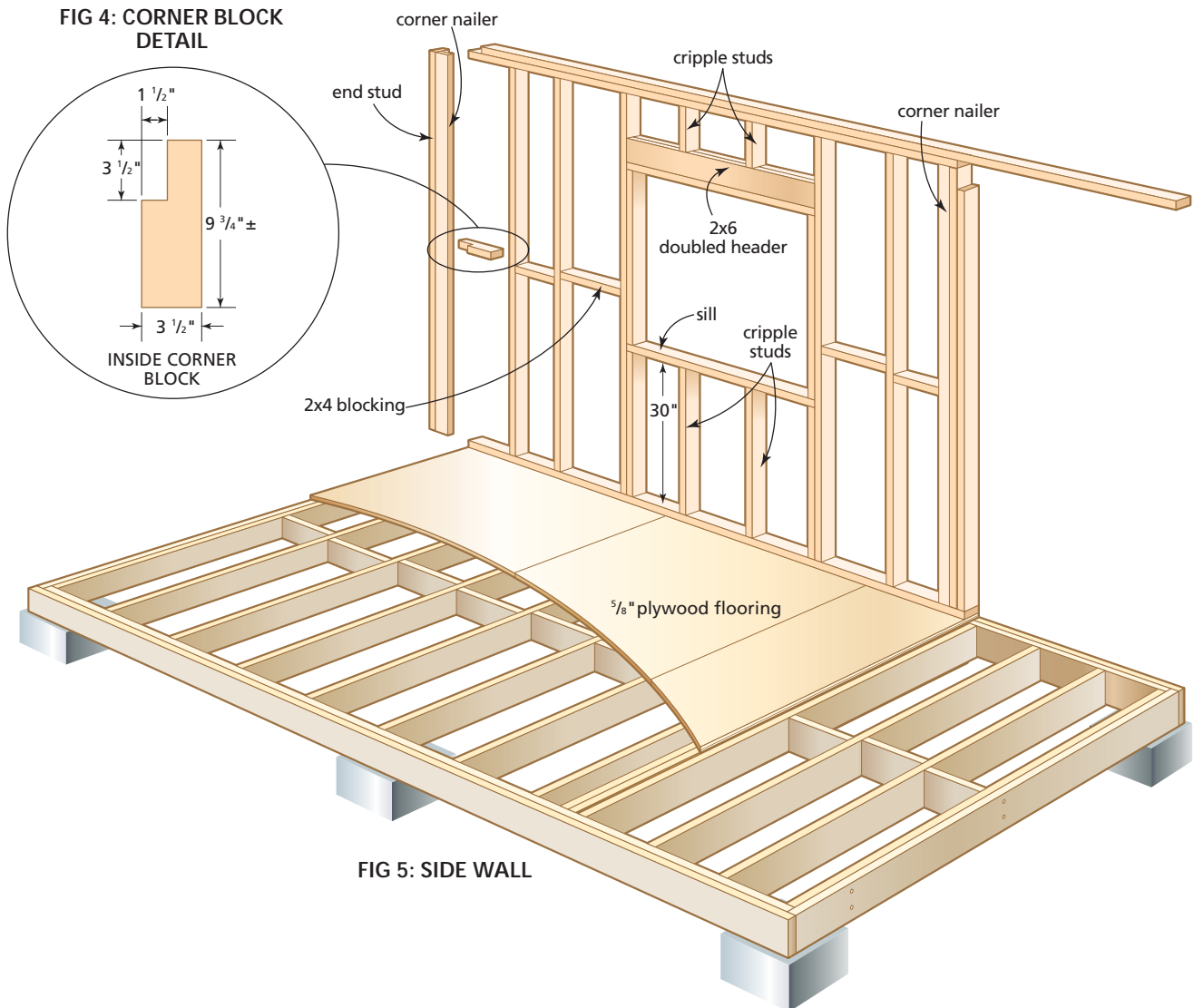

FIG 5: SIDE WALL

REAR WALL

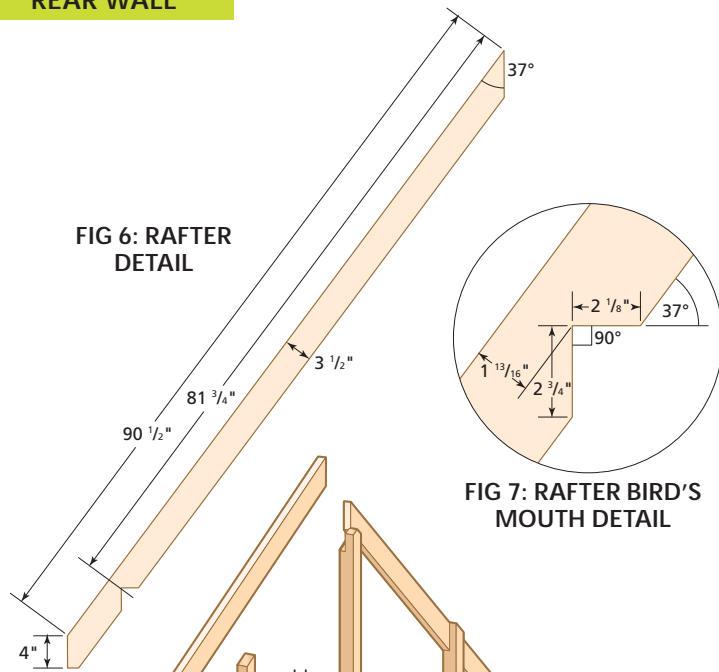

FIG 8: REAR WALL

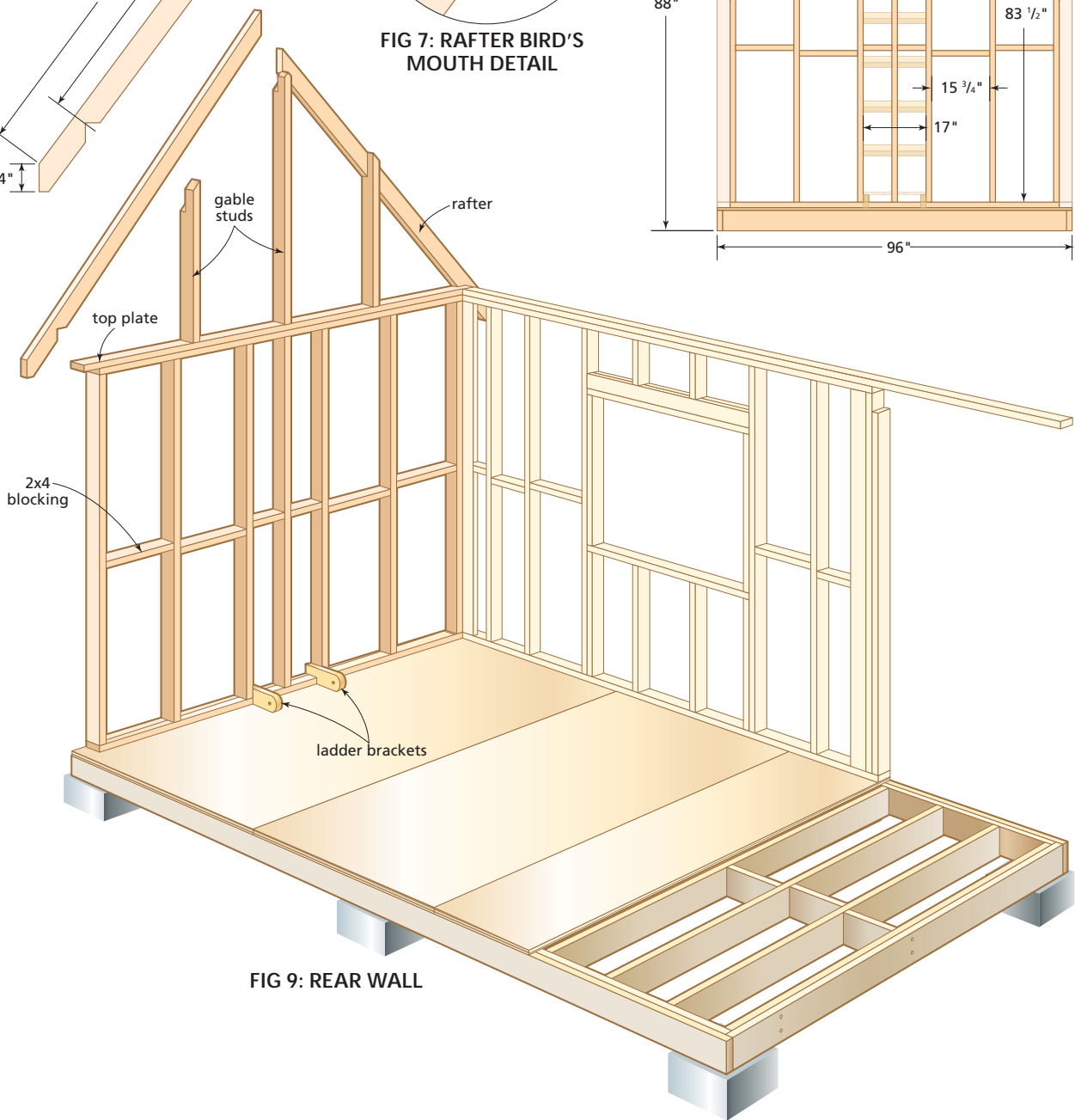
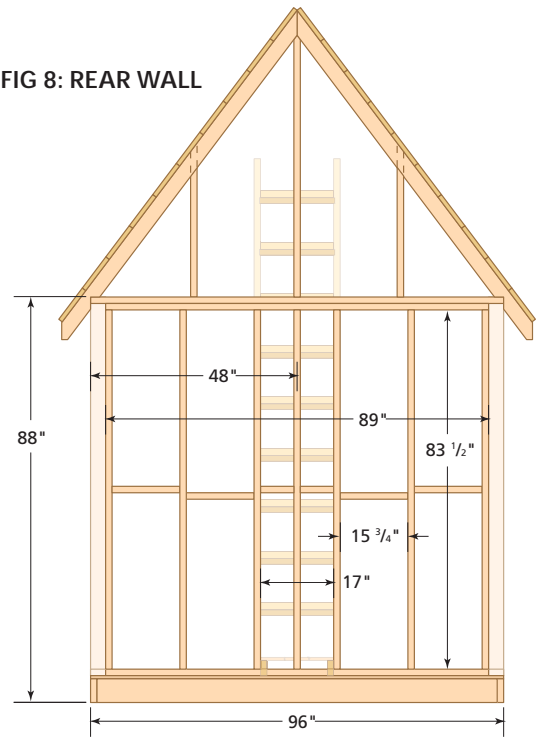

FIG 9: REAR WALL

FRONT WALL AND PORCH

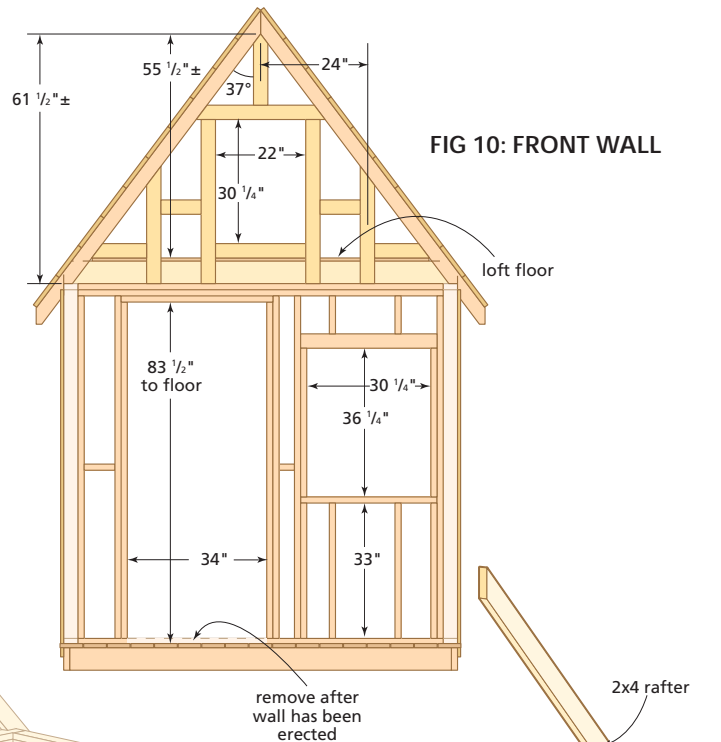

FIG 10: FRONT WALL

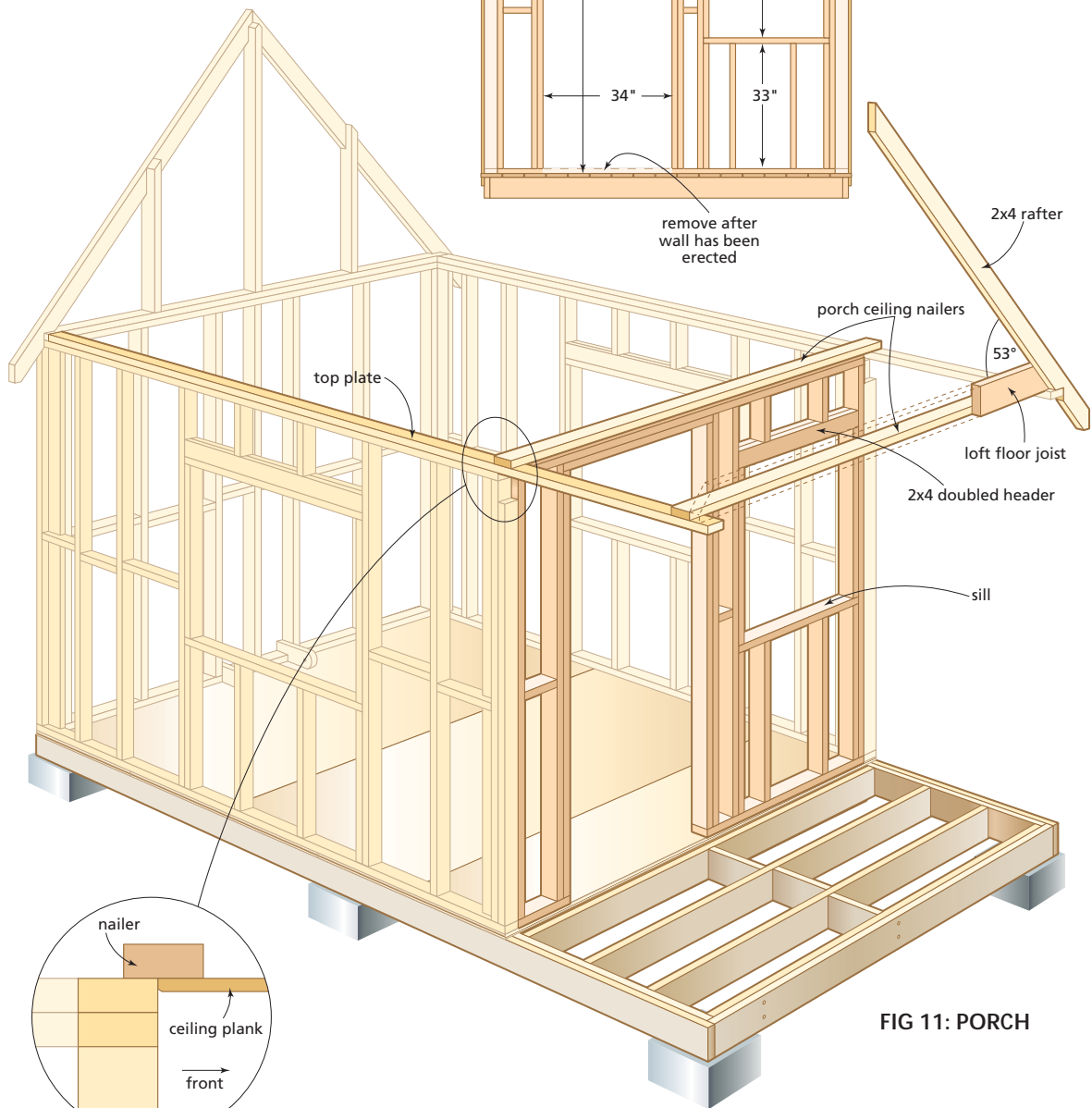

FIG 11: PORCH

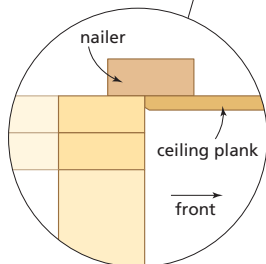

FIG 12: PORCH CEILING NAILER DETAIL

The Cottage Life Bunkie

PORCH

FIG 13: PORCH

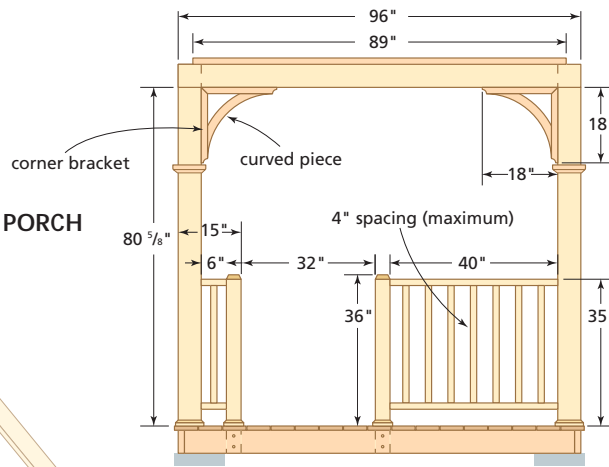

FIG 14: PORCH

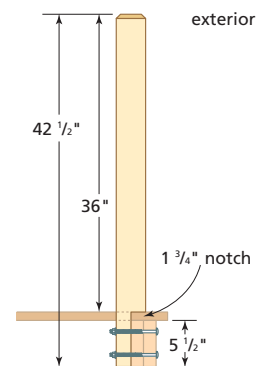
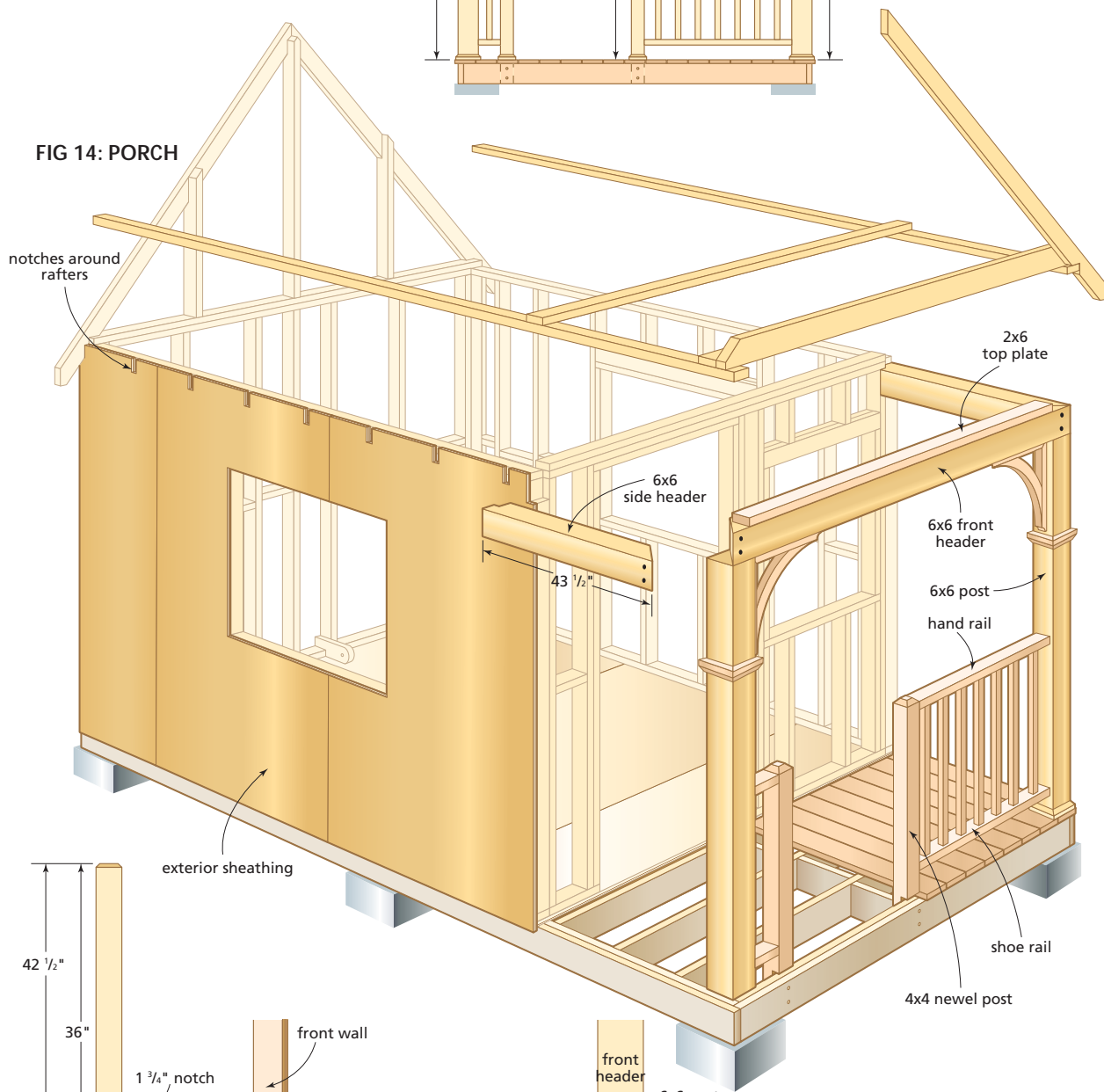

FIG 15: NEWEL POST DETAIL

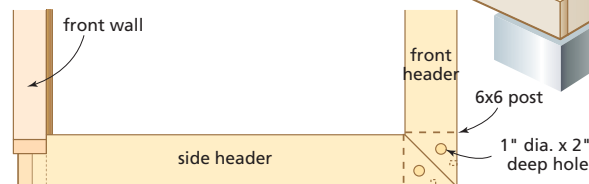

FIG 16: PORCH HEADER TOP VIEW DETAIL

ROOF AND LOFT

FIG 17: ROOFING

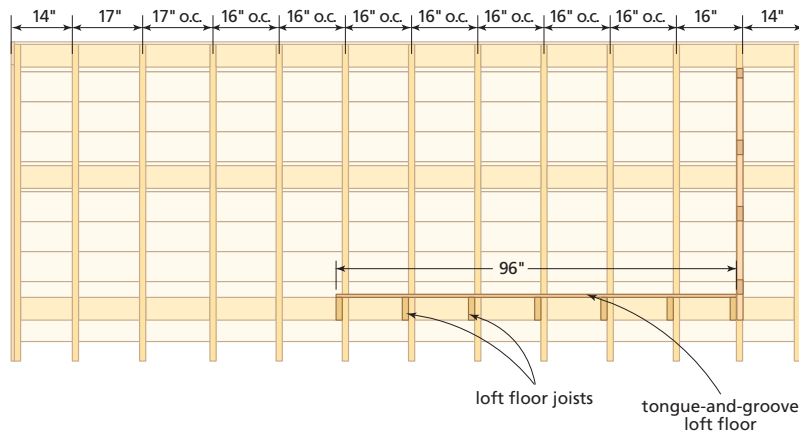

FIG 18: FRONT GABLE

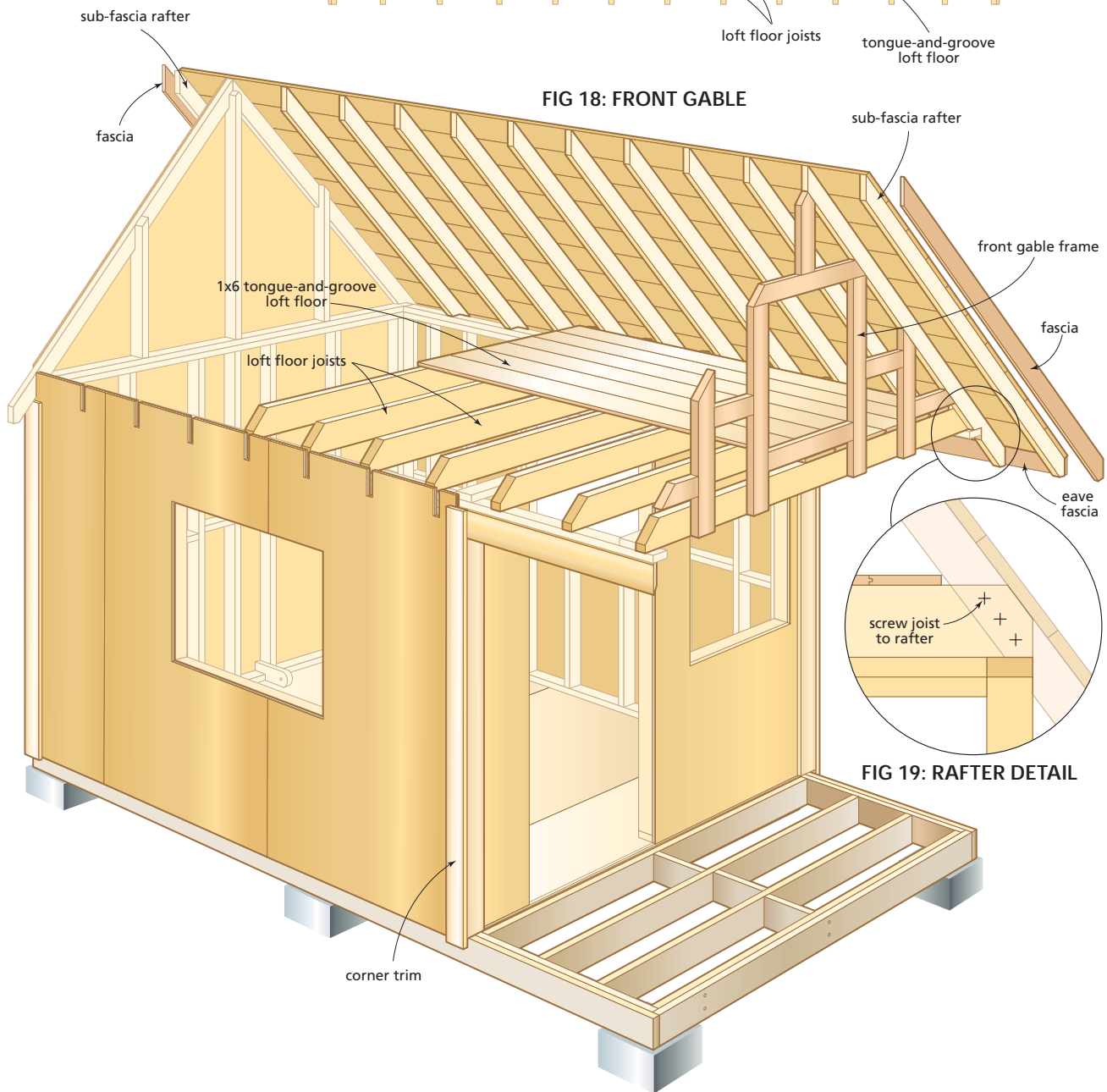

FIG 19: RAFTER DETAIL

The Cottage Life Bunkie

LOFT DETAILS

FIG 20: LOFT DETAIL

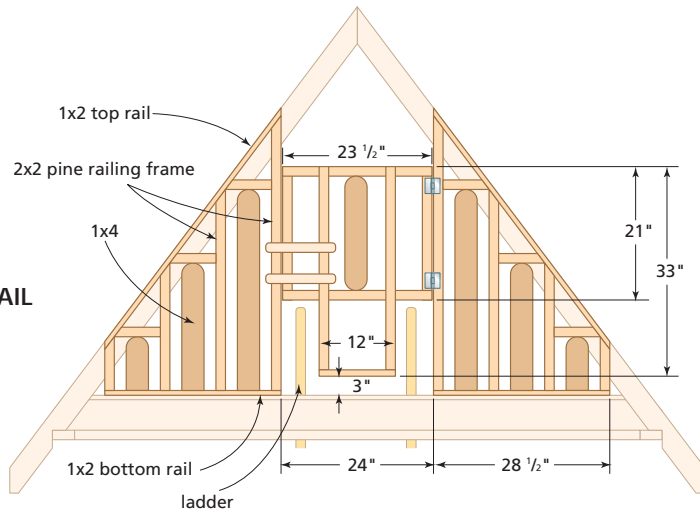
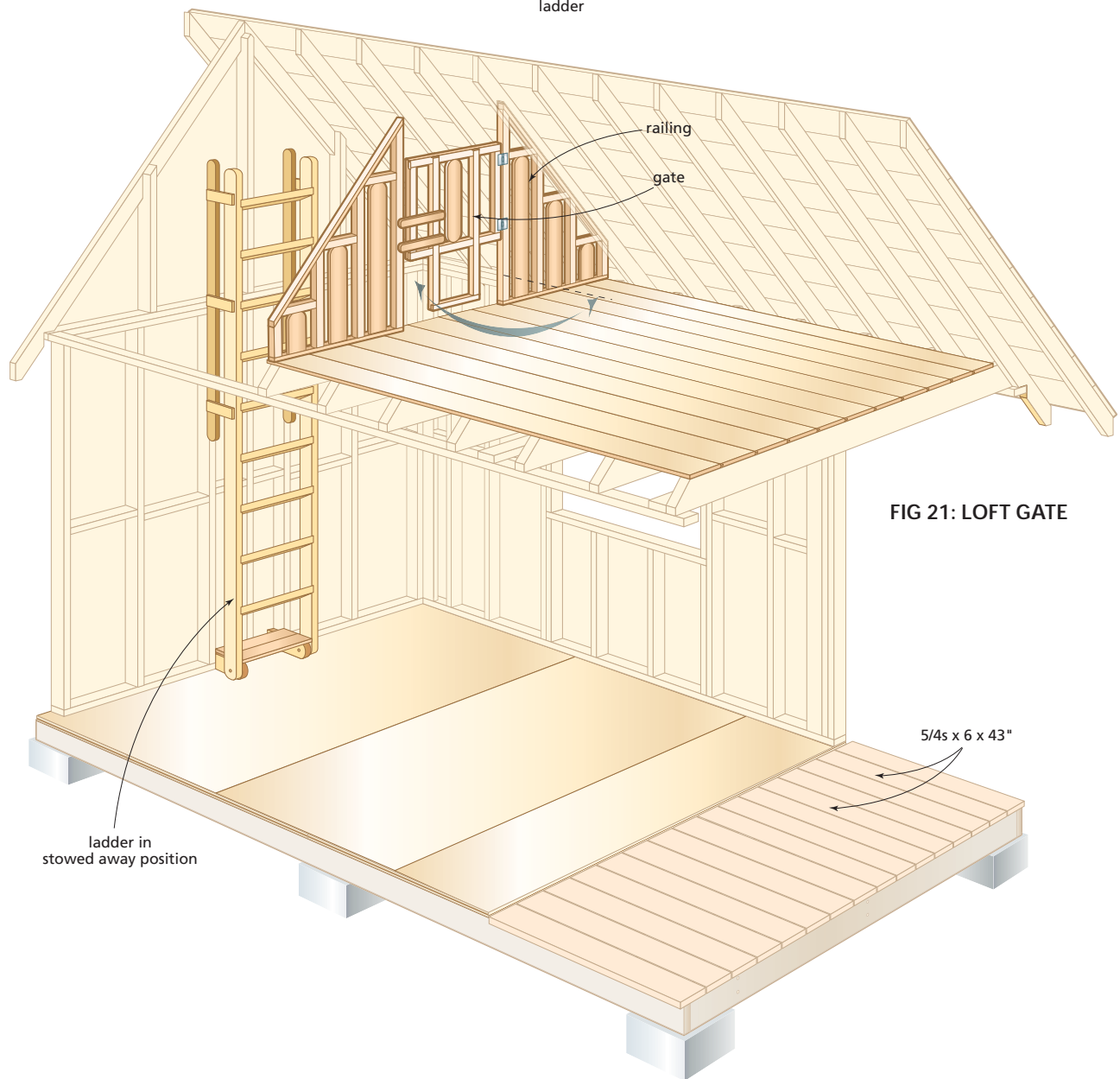

FIG 21: LOFT GATE



LOFT LADDER

FIG 22: LADDER

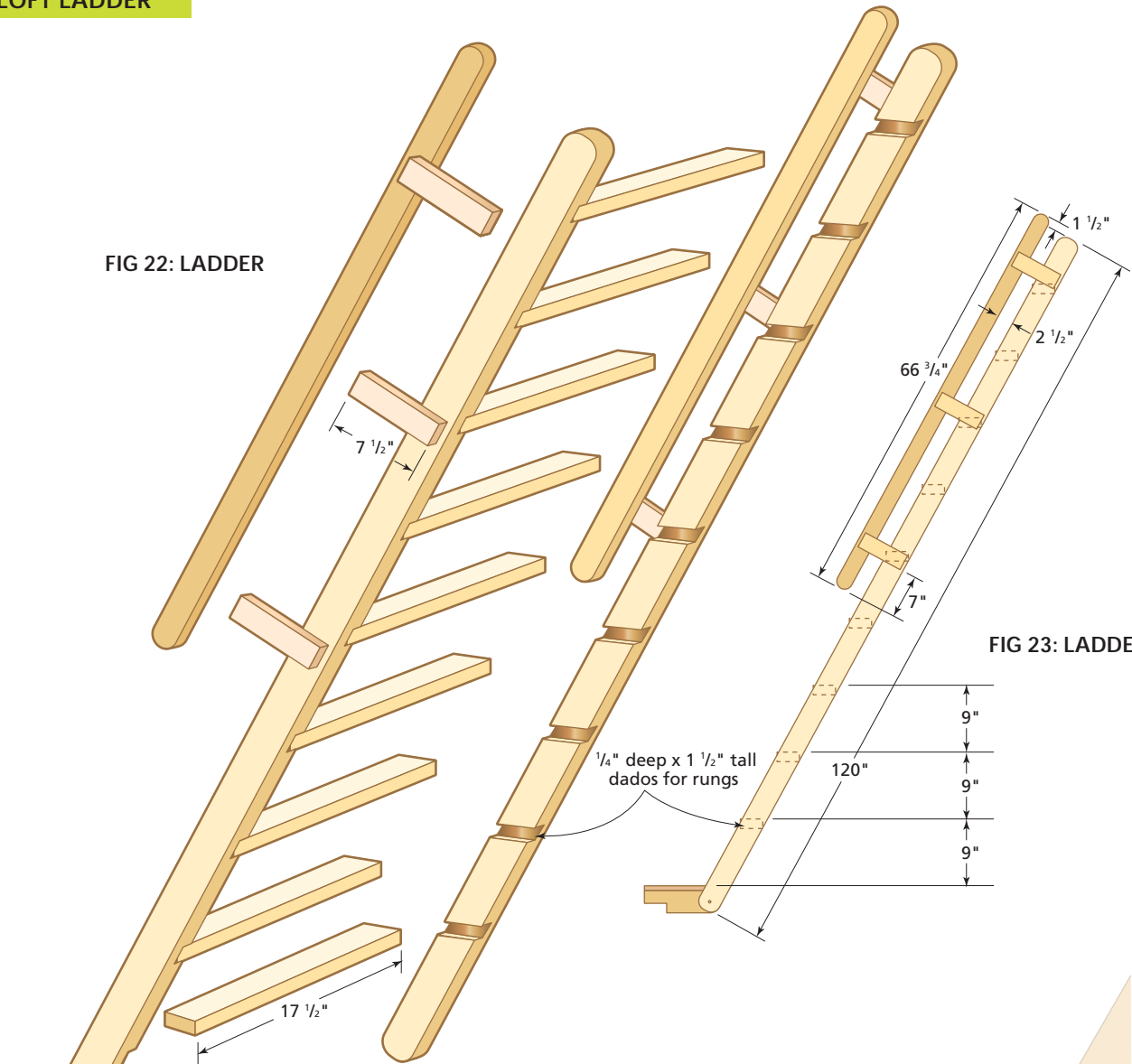

FIG 23: LADDER

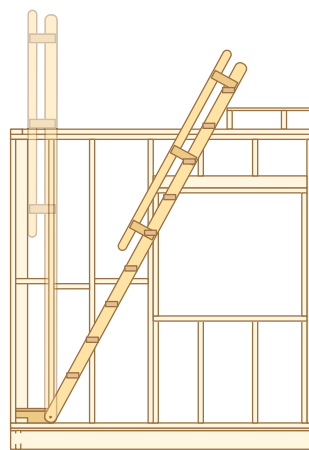

FIG 24: LADDER STORED AWAY AND IN USE

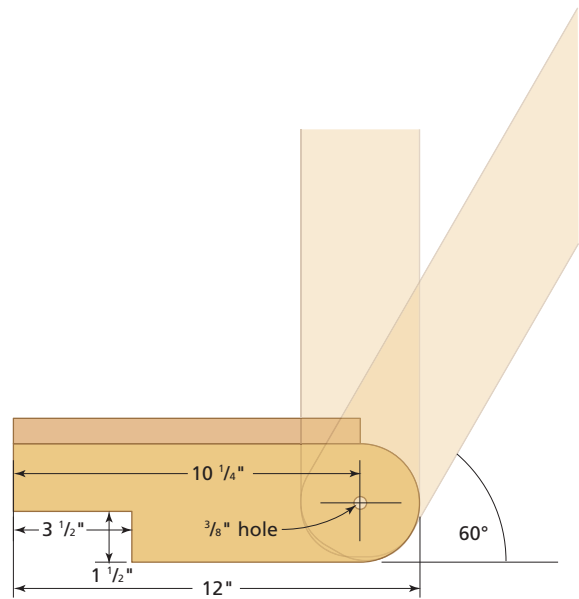

FIG 25: LADDER BRACKET DETAIL