

Schäffer Lader

THE DYNAMICS CLASS

4350 | 4360

5058 | 5370 | 5390

9300 | 9330



**Superior strength
and high lift**

YARD LOADERS, WHEEL LOADERS AND TELESCOPIC LOADERS ...

from 14 kW (20 HP) to 154 kW (210 HP). At SCHÄFFER Loaders, we have a proud 50 year history of creating loaders for individual requirements. Our customers have made us what we are today: one of the world's most competitive and successful suppliers of yard loaders, wheel loaders and telescopic loaders. Every day our team creates new custom solutions that combine years of experience with a spirit of innovation. Our products set industry standards for reliability and durability, which means you save with lower servicing costs over the life of your vehicle. The Schaffer name is your assurance of superior performance, safety and comfort for years to come.

made by SCHÄFFER



THE DYNAMICS CLASS OF SCHÄFFER: STRENGTH AND HIGH LIFT

The dynamics class of SCHÄFFER: Still compact, efficient wheel loader for demanding tasks. The standard Z kinematics with high break out forces fulfills highest performance requirements in construction business, in farming and all other industry. Typical of SCHÄFFER: the enormous lifting height. The Models 9300 Z/9330 Z is capable to lift loads up to 3.80 m, hardly another wheel loader of this class raises more highly.

The absolutely area Schäffer loaders are particularly popular for is the compact style and excellent agility, too. The machines increase productivity, save time and costs.

Wheel loader with built-in efficiency, naturally made by SCHÄFFER.

THE DYNAMIC CLASS

4350 Z 37 kW (50 HP)	4360 Z 44 kW (60 HP)
5058 Z 44 kW (60 HP)	5058 ZS 51 kW (70 HP)
5370 Z 51 kW (70 HP)	5390 Z 63 kW (86 HP)
9300 Z 81 kW (110 HP)	9330 Z 96 kW (130 HP)





THE 4300 SCHÄFFER SERIES: THE COMPACT LOADERS WITH THE Z-BAR BOOM

Versatile, powerful and strong - the robust 4300 series makes the daily work so easy. Hard to believe what they can cope with. And because of its agility and low overall height exactly there where larger machines fail.



PURE ERGONOMICS



4360

ERGONOMICS AT ITS BEST

The redesigned cabin of the 4300er series offers a very comfortable work environment. Here, the driver feels fit even after long working days. All operating and control instruments are clearly laid out and user friendly. The comfortable seat and the best leg room leave nothing to be desired. The generous use of glass allows the driver perfect visibility to the tool and maneuvering. All hydraulic functions can be integrated in the joystick, providing precise and sensitive single-lever control. The left hand remains on the steering wheel for safe operation.

STANDARD ON 4300 SERIES MACHINES WITH CAB:



2x Dual Power working lamp front,
1x Single Power rear



Switch bar,
electric plug



Multifunctional joystick



Bottle holder,
battery switch



Perfect view upwards with roller blind

THE 5300s WHEEL LOADERS OF SCHÄFFER: WORK POWERFULLY!

The 5300s series of SCHÄFFER sets standards. Compact machine measurements at greatest possible strength and ergonomics. The 5370 Z and 5390 Z are the top models within the 5000 series machines. They offer extremely high power and agility. Thanks to optimized geometry of loading arm the lifting capacity was improved again. The Z-kinematics delivers a comparative high tear out force, the parallel movement works very well. The SCV-cab is state of the art. The operator will enjoy his tasks even on long working days pretty much.

The SCV-Cab: ROPS and FOPS approved; very spacious, best ergonomics and all round view.

Kubota: World market leader of compact diesel motors. Clean, moneysaving, powerful.

Original SCHÄFFER planetary axles: very strong, high pushing power due to best setup of axle, hydrostatic drive and motor; payload of 7 t per axle; with automatic limited slip brakes. Oscillating rear axle for best stability.

Extremely strong articulation joint.

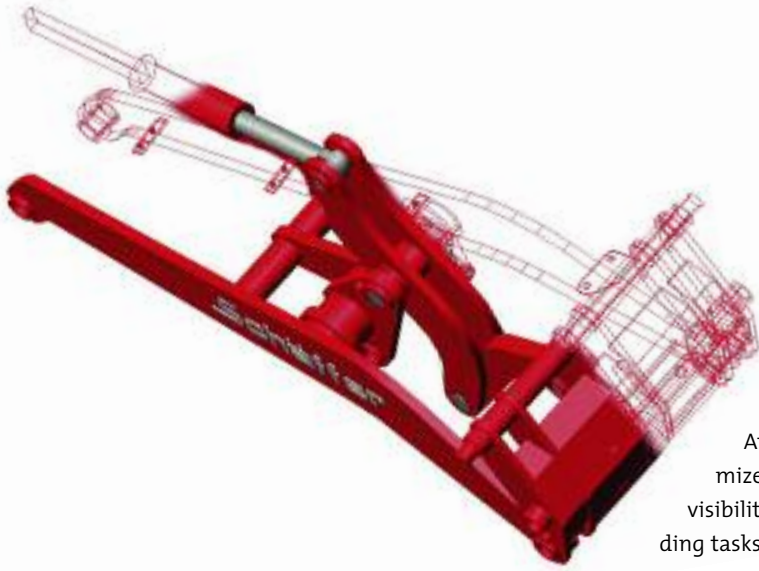

COMPUTER OPTIMIZED LOADING ARM WITH Z KINEMATICS - SIMPLY STRONG

Greatest break out and lifting forces, that's what SCHÄFFER stands for. At the computer with three-dimensional CAD system designed and optimized by our engineers and masters with 50 years experience. Due to better visibility narrow at the mounting and more wider at the tool. Even at demanding tasks all desires are met.

THE 5300 SERIES OF SCHÄFFER: ADVANTAGES AT A GLANCE

Low boom pivot for perfect view.

Z-bar linkage for
high break out force.

Very strong carriage, fast and safe
hydraulic coupling of tools.

Versatile due to big
range of tools
and optional
equipment.

CAD optimized lifting arm,
best lifting height and reach,
perfect parallel lift.



SCHÄFFER 9300 Z/9330 Z: WITH 3.80 M LIFTING HEIGHT AT TOP OF IT'S CLASS

Nothing can replace lifting height – but lifting height. The 3.80 m of the SCHÄFFER 9300 Z/9330 Z are absolutely unchallenged. Good enough to stack about 8 bales of straw on top of each other. High feeder mixers or bio-gas plants are another specialty of the 9300 Z/9330 Z. Ton on ton easy loading, reliably over years. Only a wheel loader made by SCHÄFFER creates this.



Water cooled engines of Deutz. Indestructible, thrifty, quiet and strong. Together with SCHÄFFER 9300 series a winning team.



Oscillating axle in rear for more stability and higher excavating force.



SCHÄFFER LOADER WITH CAB "SCV"

The SCHÄFFER SCV-cab (**S**ilence/**C**omfort/**V**iew) with which the 5300 and 9300 series loaders are equipped, offers more comfort for long working days. Already from the outside the cabin shows dynamism and power. You can really enjoy climbing due to the safe steps and the largely dimensioned doors. The interior design in friendly colors conforms to the demand for high quality standards which is typical for SCHÄFFER.

The seat in its standard version already offers real comfort and setting options. If desired an air spring seat is also available. The steering-wheel is adjustable in height and inclination. All operating elements and displays are arranged clearly and logically. All work hydraulics can be dosed absolutely delicately by means of a joystick. This is supported by the use of pre-controlled valves. Arm-rest and joystick form a unit with the seat and accept all movements of the seat. Pure ergonomics! All drivers will like the rear window of the SCV-cab which can be opened to have a better circulation of air.



AS STANDARD ON SCV CAB



Perfect view upwards with roller blind



Box with cover (g300 series only)



Battery switch



Power plug



Bottle holder



2 x Dual Power working lamp front, 1 x Single Power rear



Arm-rest and joystick form a unit with the seat and accept all movements of the seat. Pure ergonomics!

TECHNICAL DATA

	4350 Z/4360 Z	5058 Z/ZS	5370 Z/5390 Z	9300 Z	9330 Z
Engine	4 Cyl. Kubota 37 kW (50 HP) 4 Cyl. Kubota Turbo 44 kW (60 HP)	4 Cyl. Kubota Turbo 44 kW (60 HP) 4 Cyl. Kubota 51 kW (70 HP)	4 Cyl. Kubota 51 kW (70 HP) 4 Cyl. Kubota Turbo 63 kW (86 HP)	4 Cyl. Deutz Turbo Intercooler 81 kW (110 HP)	4 Cyl. Deutz Turbo Intercooler 96 kW (130 HP)
Driving hydraulics	Hydrostatic automotive	Hydrostatic automotive	Hydrostatic automotive	Hydrostatic automotive	Hydrostatic automotive
Tyres	11.5/80 - 15.3 AS Option I 15.0/55 - 17 AS Option II 425/55 R17	15.0/55 - 17 AS Option I 425/55 R17 Option II 500/45-20	15.0/55-17 AS Option I 500/45-20 AS Option II 425/55 R17	405/70-20 Option I 365/70-R18 Option II 550/45-22.5	405/70-20 Option I 600/40-22.5
Service brake	Combination Hydrostatic and multiple-disk	Combination Hydrostatic and multiple-disk	Combination Hydrostatic and multiple-disk	Combination Hydrostatic and multiple-disk	Combination Hydrostatic and multiple-disk
Parking brake	Multiple Disk in Oil Bath	Multiple Disk in Oil Bath	Multiple Disk in Oil Bath	Multiple Disk in Oil Bath	Multiple Disk in Oil Bath
Working hydraulics	Flow Rate: 70 l/min Working Pressure: 200 bar	Flow Rate: 70 l/min Working Pressure: 200 bar	Flow Rate: 70 l/min Working Pressure: 200 bar	Flow Rate: 80 l/min Working Pressure: 200 bar	Flow Rate: 80 l/min Working Pressure: 200 bar
Steering	Hydraulic Articulated Pendulum Steering	Fully Hydraulic Articulated Steering	Fully Hydraulic Articulated Steering	Fully Hydraulic Articulated Steering	Fully Hydraulic Articulated Steering
Lifting capacity	2.400 kg	2.800 kg	2.800 kg/2.800 kg	4.200 kg	4.200 kg
Tip-over load, straight	2.200 kg	2.400 kg	2.600 kg/2.750 kg	3.800 kg	4.000 kg
Tip-over load, bent	1.700 kg	2.100 kg	2.250 kg/2.400 kg	3.200 kg	3.400 kg
Axles	Original SCHÄFFER axles, 6 wheel nut rim; planetary axle and automatic limited slip brake	Original SCHÄFFER axles, 6 wheel nut rim; planetary axle and automatic limited slip brake, Oscilating rear axle	Original SCHÄFFER axles, 6 wheel nut rim; planetary axle and automatic limited slip brake, Oscilating rear axle	ZF-Axles, 8 wheel nut rim; planetary axle and automatic limited slip brake, Oscilating rear axle	ZF-Axles, 8 wheel nut rim; planetary axle and automatic limited slip brake, Oscilating rear axle
Gross Vehicle Weight	protective roof: 3.400 kg cab: 3.520 kg	canopy: 3.920 kg cab: 4.070 kg	canopy: 4.150/4.520 kg cab: 4.300/4.670 kg	cab: 5.550 kg/5.950 kg*	cab: 6.100 kg
Speed	0 - 20 km/h, 2 speeds gear switching under load possible, Option: 0 - 30 km/h	0 - 20 km/h, 2 speeds gear switching under load possible,	0 - 20 km/h, 2 speeds gear switching under load possible, Option: 0 - 30 km/h	0 - 20 km/h, 2 speeds gear switching under load possible, Option: 0 - 35 km/h	0 - 20 km/h, 2 speeds gear switching under load possible, Option: 0 - 35 km/h
Electrical system	Operating Voltage 12 V	Operating Voltage 12 V	Operating Voltage 12 V	Operating Voltage 12 V	Operating Voltage 12 V
Fluid capacities	Fuel: 90 l Hydraulic oil: 60 l	Fuel: 65 l Hydraulic oil: 60 l	Fuel: 65 l Hydraulic oil: 60 l	Fuel: 95 l Hydraulic oil: 105 l	Fuel: 95 l Hydraulic oil: 105 l

* High lift



DIMENSIONS

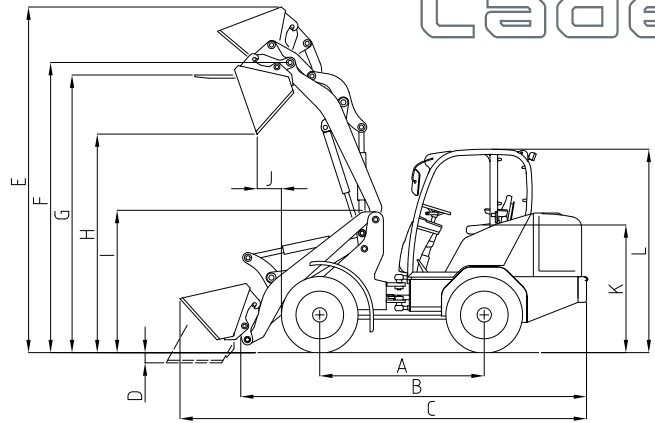
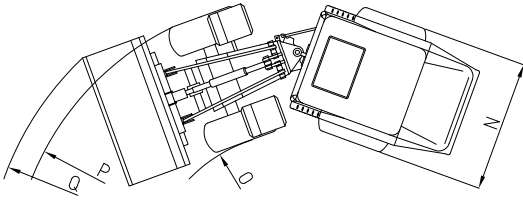

		4350 Z/4360 Z	5058 Z/ZS	5370 Z/5390 Z	9300 Z	9330 Z
A	Axle base [mm]	2.000	1.930	1.930	2.300	2.300
B	Chassis length [mm]	4.050	4.240	4.480	4.850	4.850
C	Total length with standard bucket [mm]	4.730	4.870	5.250	5.560	5.560
D	Excavating depth [mm]	120	180	180	160	160
E	Max. working height [mm]	4.060	4.070	4.070	4.035/4.435*	4.035/4.435*
F	Max. bucket pivot point [mm]	3.260	3.400	3.400	3.400/3.800*	3.400/3.800*
G	Max. loading height with pallet fork [mm]	3.050	3.175	3.175	3.175/3.575*	3.175/3.575*
H	Max. load over height [mm]	2.500	2.700	2.700	2.700/3.100*	2.700/3.100*
I	Max. dump height [mm]	1.570	1.640	1.640	1.625/1.825*	1.625/1.825*
J	Dump range [mm]	640	600	600	465	465
K	Seat height [mm]	1.270	1.340	1.340	1.510	1.510
L	Height protective roof [mm] Height cab [mm]	2.270 2.220	- 2.320	- 2.320	- 2.500	- 2.500
N	Total width [mm]	1.230 - 1.600	1.420 - 1.800	1.420 - 1.800	1.800 - 2.080	2.050 - 2.110
O	Track arc inside [mm]	1.450	1.670	1.560	1.890	1.890
P	Track arc outside [mm]	2.680	3.090	3.090	3.450	3.450
Q	External radius with standard bucket [mm]	3.010	3.750	3.750	3.900	3.900

* High lift





The way SCHÄFFER loaders are developed, built and serviced is unique. The difference is our 50 years of experience. First, we think about the operator; we want to make his work safer, more comfortable – and more profitable. To this end, we are equipped with the most modern development and production technologies at our plant in Erwitte, Germany. Ultimately, it is our associates who work with our customers to continuously develop new solutions. Long years of commitment to the company combined with an enduring spirit of innovation are the basis of our exceptional worldwide success.

The name SCHÄFFER Loaders stands for more than one-of-a-kind product quality. It also stands for safety and optimal service, which we guarantee not only in Germany but around the globe.

The purchase of a SCHÄFFER loader is the beginning of a long-term relationship. Only original replacement parts allow your machine to remain a 100% true SCHÄFFER over the years. Only then will it guarantee the reliability you rightly expect. We offer you and our service partners a 24 hour delivery service – 7 days a week, 365 days a year.

made by SCHÄFFER

SCHÄFFER offers you a product line-up of over 40 different models, each of which can be adapted to your individual requirements. Our loaders can be used in many different industries: in agriculture or construction, in horticulture or landscaping, in industry and trade, in horse husbandry or warehousing. Whatever the industry, SCHÄFFER is always your first choice.



Your Dealer:

Schaeffer Lader

SCHÄFFER MASCHINENFABRIK GMBH
Postfach 10 67 | D-59591 Erwitte
Phone +49 02943 9709-0
Fax +49 02943 9709-50
info@schaeffler-lader.de
www.schaeffler-lader.de