

Donaldson®
Torit®

EASY DUCT™
TECHNICAL MANUAL



THE EASY DUCT ADVANTAGE

- Simple to install - No special tools or training required
- Clamp-together components can be taken apart and reused
- Flexible - Easily connects to existing ductwork
- Components and adapters fit every system
- Adjustable duct fittings simplify connections
- Smooth interior surface helps prevent clogs



TABLE OF CONTENTS

DESCRIPTION	PAGE
Adjustable Nipple Assembly For Dry Application	34
Adjustable O-Ring Material	4
Air Volume Chart	37
Blast Gate (Auto)	17
Blast Gates (Manual & Energy Saving)	18-19
Bleed-In Valve	15
Branch Styles	31
Ceiling Hanging Method	23
Clamp Diagram	3
Clamp Gasketing Alternatives	4
Construction Methods	5
Diverter Valve	20
Dry System Installation	30
Elbows & Fittings	6
Engineering Specifications	1
Flanged Duct Specifications	2
Flashing (Wall & Roof)	21
Gauge Limitations	8
Gauge Upgrades For Elbows	7
Gripple Hanger System	24
High Temp Fume Or Exhaust Applications	28
In-Line Sound Silencer	26
Installing An In-Cut Or Tap-In	16
Labor Guidlines & What To Be Aware Of When Ordering	27
Leakage	10
No-Loss Stack-Head	26
Oil Mist Or Wet Application For Pipe	35
Oil Mist Or Wet Application For Installation Of Adjustable Nipple	36
Pipe Stand With Bracket Hanger	23
Reducer Styles	32
Rigid & Ultra Flex Hose	14
Rubber Flex Hose	13
Sizing A System & Cfm/Fpm Chart	11
Sizing Branches	33
Sizing Elbows & Special Components	12
Structural Integrity & Collapsibility	9
Wall Mounting	22
Wet System Installation	29

ENGINEERING SPECIFICATIONS

DUCT-WORK:

All duct-work shall be of a clamp-together design using a die-formed, rolled edge in which is then joined together by a single lever clamp of similar material. All clamp together ducting shall be of continuous laser welded construction along the longitudinal seam of the rolled form duct with the exception of the 3" which is lock formed. All connections shall have Nitrile seal in clamp for standard installs and a Gortex seal for mist or food grade applications.

Duct material sheet blanks are five feet long, which is then rolled and fused Together with a laser weld process along the longitudinal seam.

The ends of the duct are then pressed in a die to form a rolled bead on each end of the duct. This rolled-end is used for clamping components together as well as reinforcement every 5 feet.

COMPONENT MATERIAL:

Straight duct and other connecting components to be constructed of galvanized sheets produced by the continuous galvanizing process in which conforms to ASTM-A-527, and commercial quality ASTM A-527. Galvanized sheeting is produced with a minimum spangle.

Stainless duct-work is constructed of stainless steel to be 304 2B finish (2B finish in annealed, pickled and bright cold rolled).

ADDITIONAL INFORMATION:

For more information regarding gauges of materials, temperature ratings etc. Refer to charts contained in this Technical-Specification Manual.

Duct diameters for Easy Duct as follows:

Easy Duct 3" through 17" available in 1" increments
 18" through 24 " available in 2" increments

NOTE: 3" DUCT IS LOCK FORM, NOT LASER WELDED

FLANGE DUCT SPECIFICATION

VAN-STONE FLANGE CONNECTION CROSS SECTION

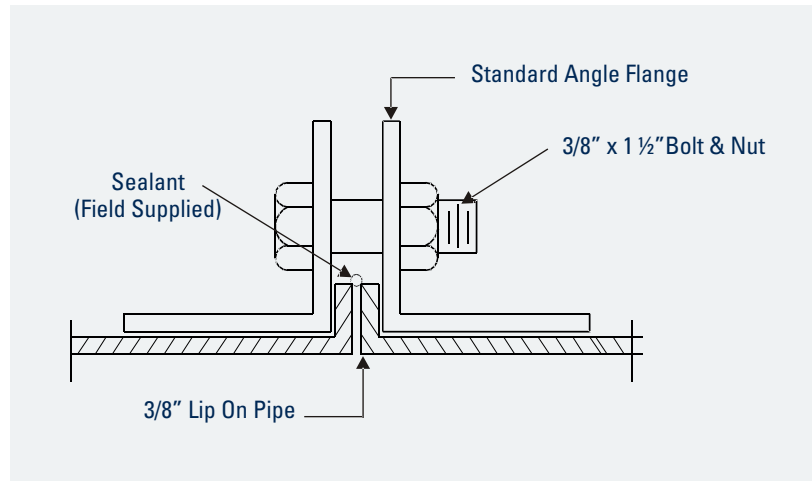

A) "Flanged" = Material sheet blanks are 78.75" lg. and rolled with a longitudinal lock formed seam. A angle flange made from angle bar stock rolled on edge is placed on the end of the duct using a Van Stone Flange Connection as illustrated above. (See Easy Duct Catalog for sizes)

B) Duct should be supported as follows:

*3"-10" diameter = 12' -15' centers

*11"-24" diameter = 15' - 20' centers

Supports should be installed to provide lateral stability to entire piping system.

However, each installation differs and should be evaluated properly.

C) Duct diameters for FLANGE DUCT as follows:

3" through 18" available in 1" increments

20" through 40 " available in 2" increments

COMPONENT MATERIAL:

A) Components constructed of galvanized steel sheets produced by the Continuous Galvanizing Process, and Commercial Quality-ASTM A-526. Galvanized sheeting is produced with a minimum spangle with coating weight of G-90.

B) Components constructed of stainless steel will be of 304 2B finish. {2B finish is annealed, pickled, and bright cold rolled

C) Components constructed of other material- Contact Easy Duct.

CLAMP DIAGRAM

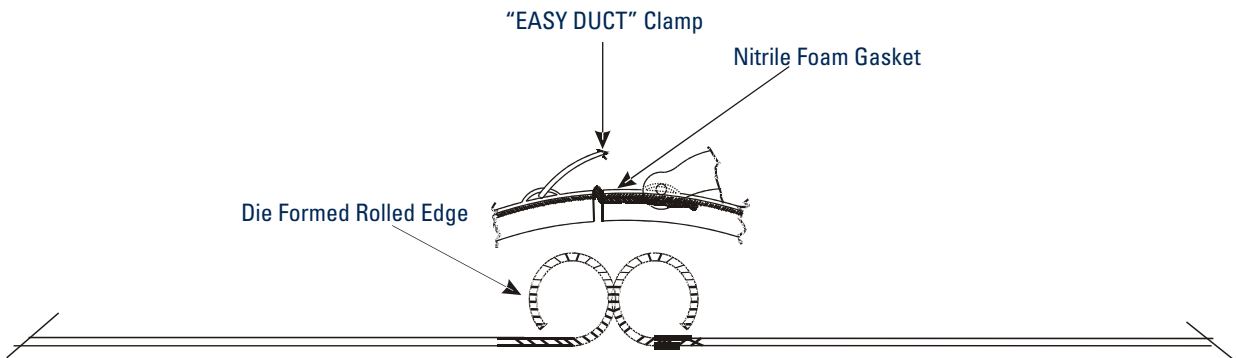
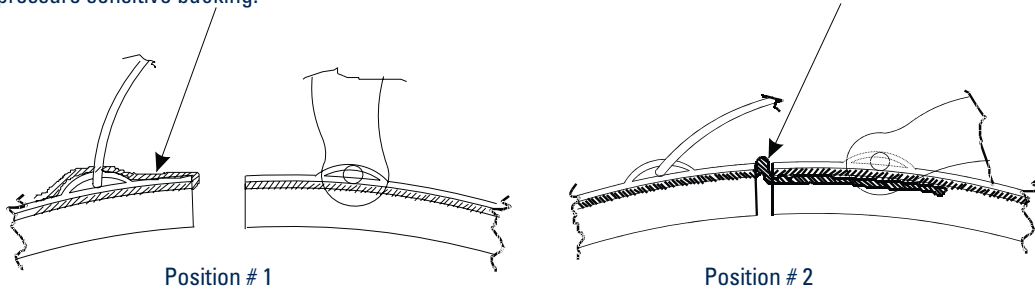
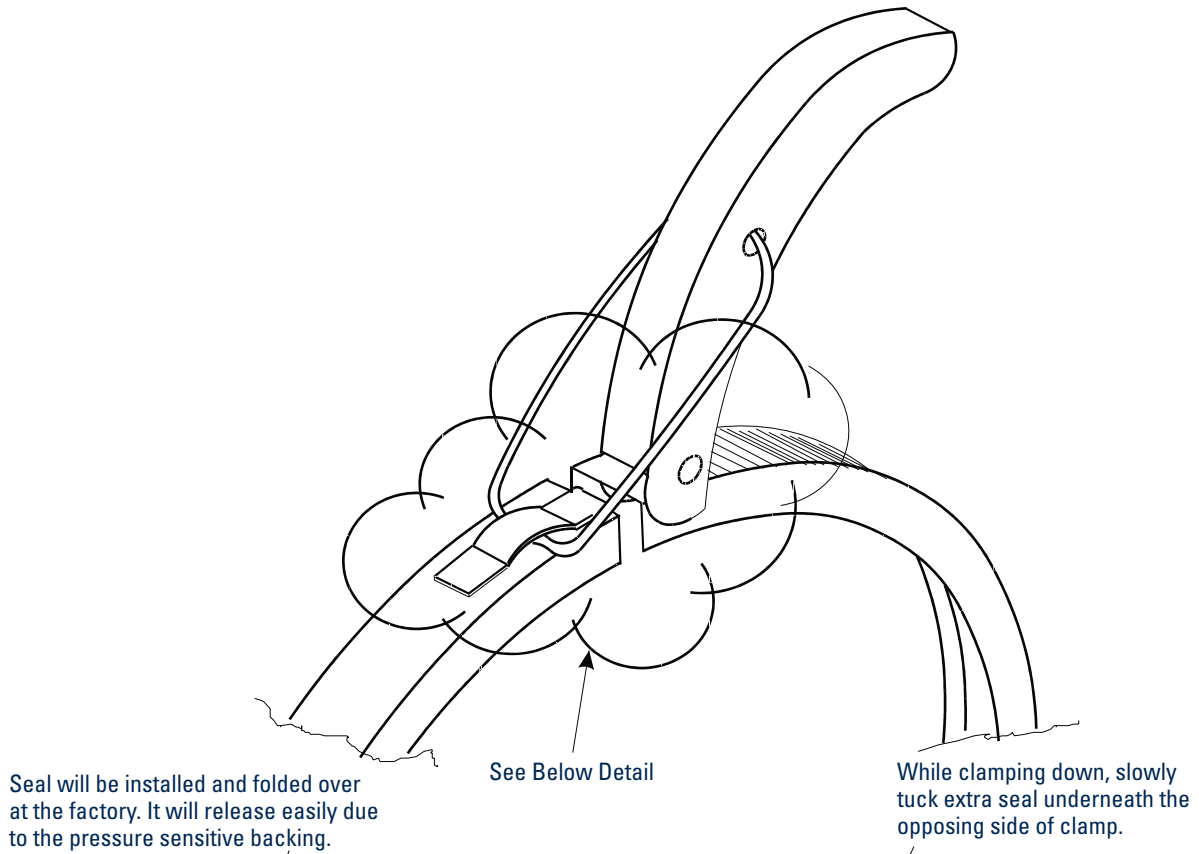

CLAMP GASKETING ALTERNATIVES ADJUSTABLE NIPPLE O-RING MATERIAL

CLAMP GASKETING ALTERNATIVES

1. NITRILE GASKET-STANDARD
 - Service temperature: -104 deg to +158 deg with an intermittent max temp of +194 deg.
 - Standard seal installed in clamp
 - The standard specifications meet ASTM D 1056.
 - 3/8" Gasket for 4",5",6"
 - 1/2 " Gasket for 7" and larger
2. INERTECH PTFE GASKETTAPE
 - Service temperature -450 DEG F. to 600 DEG F
 - FDA suitable for use in food and pharmaceutical industries
 - Not degraded by any common chemicals [0-14 PH range]
 - Non-contaminating and non-aging
 - 3/8" gasket for 4",5",6"
 - 1/2" gasket for 7" and larger

TEMPERATURE RATINGS

1. Black rubber O-Ring material
Service temperature:
 - -40 DEG F. TO 250 DEG F.
 - 70 Duro-Meter hardness
2. Red rubber silicon O-Ring material
Service temperature: -100 DEG F. to 500 DEG F.
 - FDA suitable for use in food and pharmaceutical industries
 - Specification: ZZ-R-765 Class 2A and 2B grade 70 AMS-3304E and 3304F and 3303G
3. Diverter gasket 200 DEG F.
4. (RFH) rubber hose 275 DEG F.
5. UHMW seals in blast gates 180 DEG F.
6. Teflon seals 300 DEG F.
7. Galvanized ducting 500 DEG F.
8. Stainless steel ducting 800 DEG F.
9. RTV high temperature caulk 500 DEG F.
10. Standard caulk up to 250 DEG F.

CONSTRUCTION METHODS

1. LONGITUDINAL LASER WELD SEAM FOR "EASY DUCT" PIPE

* Applies to all straight duct up to 22", and adapters, nipples and collars and most elbows.

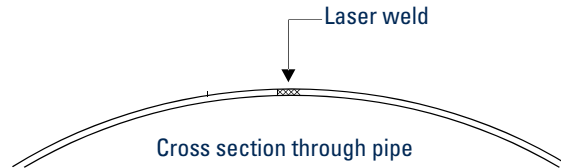

2. STANDING SEAM

* Applied to segmented elbows, offsets and end caps.

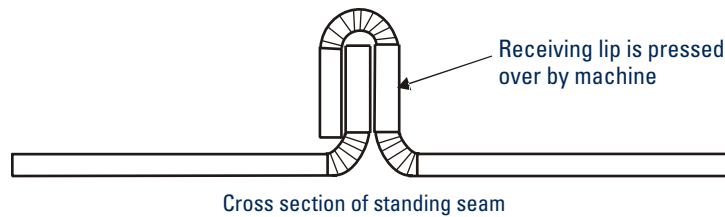

3. LONGITUDINAL LOCK FORM SEAM ON FLANGE PIPE

* Applies to all straight duct lengths flanged.

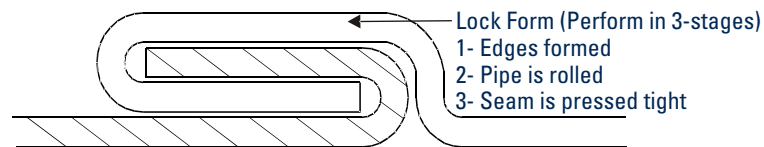

4. HEMMED, SPOT WELDED SEAM CONSTRUCTION AND EASY DUCT COLLAR CONNECTION

* Applies to all branches, reducers, in-cuts etc.

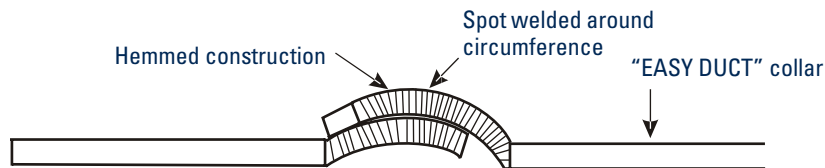

5. STANDARD SEAM JOINING METHOD ON HOODS BOXES TRANSITIONS AND SPECIALTY ITEMS

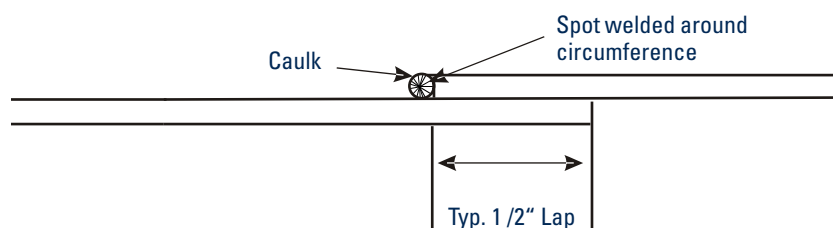

ELBOWS & FITTINGS

ELBOWS

- A) Standard elbows will have a center line radii of 1 x dia & 1.5 x dia as specified in catalog. Longer radius elbows are available upon request.
- B) Standard elbows 3" to 7" are pressed formed, and 8" and larger are gored construction with a lock form standing seam every 15 degrees. Gore type elbows are produced as follows:

ANGLE IN DEGREES	NUMBER OF GORES @ 15 DEG
0 – 30	3
31 – 45	4
46 – 60	5
61 – 90	7

FITTINGS

- A) Branch fittings are produced to have a concentric design, as they taper to a specific dimension. Joints are lapped, spot welded, cleaned, and painted with KRYLON Industrial Tough Coat, Acrylic Enamel #1760 Aluminum. Seams are sealed with 3M Scotch-Seal (R) 2084 grey sealant.
- B) Fitting gauges vary from 22 to 20 gauge depending on the configuration of the branch or fitting. If exact gauge is required, contact factory for more information.
- C) All standard branch fittings are produced on a 30 degree angle, however other angles are available upon request.
- D) As a normal practice, internal welds are not cleaned or painted. Cleaning or painting the inside is an option based on the customer’s application and is done only at the customer’s request with an upcharge.

EXAMPLES OF VARIOUS FITTINGS AVAILABLE

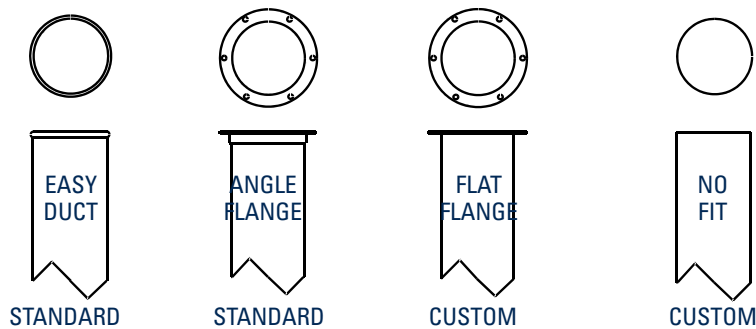

INFORMATION NEEDED TO ORDER A CUSTOM FLANGE

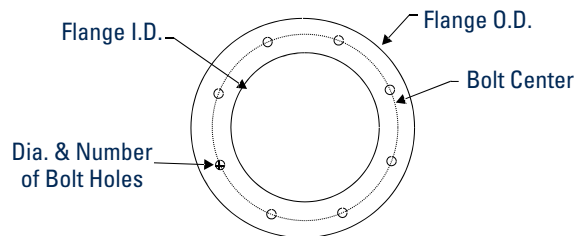

GAUGE UPGRADES FOR ELBOWS

ELBOW DIAMETER	GALV STD GAUGE	SS STD GAUGE	ONE GAUGE UPGRADE	MAX LSB STYLE ELBOW
3"	24	14 TUBED	N/A	N/A
4"	24	14 TUBED	N/A	N/A
5"	24	14 TUBED	N/A	N/A
6"	24	14 TUBED	N/A	N/A
7"	24	22	20	16
8"	22	22	20	16
9"	22	22	20	16
10"	22	22	20	16
11"	22	22	20	16
12"	22	22	20	16
13"	20	20	18	16
14"	20	20	18	16
15"	20	20	18	16
16"	20	20	18	16
17"	20	20	18	16
18"	20	20	18	16
19"	20	20	18	16
20"	20	20	18	16
21"	20	20	18	16
22"	20	20	18	16
23"	20	20	18	16
24"	20	20	18	16
26"	18	18	18	16
28"	18	18	18	16
30"	18	18	18	16
32"	18	18	18	16
34"	18	18	18	16
36"	18	18	16	16
38"	18	18	16	16
40"	18	18	16	16

GAUGE LIMITATIONS

DIA	PIPE		STD GAUGE	NIPPLE		STD GAUGE	MAX GALV GA		MAX SS GA UPGRADE
	ID	OD		ID	OD		PIPE	NIPPLE	
3"	3.05	3.11	22	3.16	3.22	23	N/A	N/A	N/A
4"	3.86	3.92	22	3.98	4.04	22	22	22	22
5"	4.86	4.92	22	4.98	5.04	22	22	22	22
6"	5.86	5.92	22	5.98	6.04	22	22	22	22
7"	6.9	6.96	22	7.01	7.063	22	20	20	20
8"	7.9	7.96	22	8.01	8.063	22	18	18	20
9"	8.9	9.5	22	9.01	9.063	22	18	18	20
10"	9.94	10	22	10.05	10.067	22	18	18	20
11"	11	11.06	22	11.12	11.18	22	18	18	18
12"	12	12.06	22	12.12	12.18	22	18	18	18
13"	13	13.074	20	13.12	13.19	20	18	18	18
14"	14	14.074	20	14.12	14.19	20	18	18	18
15"	15	15.074	20	15.12	15.19	20	18	18	18
16"	16	16.074	20	16.12	16.19	20	18	18	18
17"	17	17.074	20	17.07	17.15	20	18	18	18
18"	18	18.074	20	18.12	18.19	20	18	18	18
19"	19	19.074	20	19.12	19.19	20	18	18	18
20"	20	20.074	20	20.12	20.19	20	18	18	18
21"	21	21.074	20	21.12	21.19	20	18	18	18
22"	22	22.074	20	22.12	22.19	20	18	18	18
23"	23	23.074	20	23.12	23.19	20	18	18	18
24"	24	24.074	20	24.12	24.19	20	18	18	18

NOTE: PIP NIPPLES MAX LENGTH SAME AS PIP 6/12/03

STRUCTURAL INTEGRITY

The Laser Welded Easy Duct System has been used in many different industrial applications, and under various negative static pressures.

The typical design range we see in our applications, range from -2"wg to -28"wg, however we have some systems operating at vacuums of -32"wg to -42"wg under normal operating parameters. Should these levels of static pressure be required, we suggest an alternative seal be used in the clamp such as the white Gortex Seal. This increases the sealing properties on the connection joint.

Please take into account that our pipe comes in 5' lengths with a rolled lip on each end, thus providing reinforcement every 5', which presents a sound structural design that should be stronger than any pipe in its class.

COLLAPSIBILITY STRENGTH OF "EASY DUCT" PIPING

Each size of piping has been tested for strength against collapsing. The piping was exposed to constant positive pressure and constant vacuum. Each pipe was exposed to a maximum capacity of the test equipment of 80" wg of vacuum and positive pressure. None of the pipe showed any form of deformation during the test. Pipe and fittings must be installed in accordance with Easy Duct's standard specifications and normal good workmanship practices.

LEAKAGE

All fit together ducting systems allow for some degree of leakage. 'EASY DUCT' ducting is no exception and is not sold as an airtight system. In addition to standard Nitrile foam gasket, Easy Duct offers special clamp gasket material for high heat and enhanced sealing. Further, the applying of sealants to the individual rolled ends can enhance the tightness of the system. However, the "EASY DUCT" system is sold as a quick way of installing and modifying duct-work while at the same time retaining the usability of each component. In short, "EASY DUCT" is meant to be able to be taken apart, re-assembled, stored or moved. Completely eliminating the possibility for leakage jeopardizes the inherent benefits of the duct.

LEAKAGE CLASS

While Easy Duct is currently unaware of any method of evaluating dust collection piping alone, the following data is presented using the criteria for all duct, including HVAC. This data is presented only for the purpose of indicating acceptability of the Easy Duct in dust/fume removal in a negative pressure situations and should not be confused with the ducting that uses tape or gaskets as sealant in the positive conveyance of air.

LEAKAGE CLASS DETERMINED IN ACCORDANCE WITH SMACNA

DUCT SIZE	AVG. LEAKAGE PER 100 FT.		SMACNA CLASS
	5" SP	10" SP	
4" 6"	5 CFM	6 CFM	3
7" 10"	2.5 CFM	3.5 CFM	3
11" 24"	2 CFM	4 CFM	3

LEAKAGE RATE

Standard "EASY DUCT" is designed to provide tight sealing and efficient airflow under negative pressures. To that end we are providing the following information for piping situations where fan sizing is of extreme importance. The following data was obtained using standard components and was performed in accordance with the SMACNA, "HVAC AIR DUCT LEAKAGE TEST MANUAL". The information gives the leakage rate per joint of duct at various pressures. To utilize the chart, count the number of clamps (this equals the number of pieces) per size and multiply by the number given beside the corresponding diameter and under the applicable pressure. These numbers assume that the product is correctly installed; free of dents in the joining ends and that the gasket in place. Special gasket material and sealants will increase the sealing capabilities.

LEAKAGE RATE IN CFM PER JOINT

DIA INCHES	3 WG	5 WG	7.5 WG	10 WG	15 WG	20 WG	25 WG	30 WG
4	0.20	0.25	0.30	0.30	0.35	0.50	0.60	0.80
5	0.20	0.25	0.30	0.30	0.35	0.50	0.60	0.80
6	0.20	0.25	0.30	0.30	0.35	0.50	0.60	0.80
7	0.20	0.25	0.30	0.30	0.35	0.50	0.60	0.80
8	0.20	0.25	0.30	0.30	0.35	0.50	0.60	0.80
9	0.20	0.25	0.30	0.30	0.35	0.50	0.60	0.80
10	0.20	0.25	0.30	0.30	0.35	0.50	0.60	0.80
12	0.30	0.30	0.40	0.40	0.40	0.60	0.70	0.90
14	0.30	0.30	0.50	0.70	0.80	0.80	0.90	1.10
16	0.30	0.40	0.60	0.70	1.00	1.10	1.20	1.40
18	0.40	0.40	0.70	0.80	1.10	1.30	1.50	1.70
20	0.40	0.60	0.80	0.90	1.20	1.50	1.70	2.00
22	0.40	0.60	0.80	1.10	1.40	1.50	2.00	2.20

SIZING A SYSTEM CFM/FPM CHART

Easy Duct offers assistance to those sales people and customers who have never designed a ducting system before. We can assist you in determining the correct duct size and configuration that will supply you with the correct flow.

We have the ability to assist customers in designing a blast-gated system; taking into account flow dynamics that will be affected by blast gates. While blast gates can be used to effectively utilize an undersized filtering system, they can also destroy the flow if not properly placed.

USING THE CFM / FPM CHART

Different materials need to be moved at different velocities so as to prevent the material from falling out of the air stream. For example: wood chips and saw dust flow well at 4500 feet per minute. Referring to the chart, you will see that a 4" duct will convey 395 CFM at 4500 FPM. This will mean that a 4" pick-up on a machine will take 395 CFM from your filtering system; or working in reverse, if you know that a machine will require approximately 400 CFM to remove the waste, then you should design a 4" duct for the purpose.

AIR VOLUME IN DUCTS IN CUBIC FEET PER MINUTE (CFM)											
VELOCITY IN FEET PER MINUTE (FPM)											
DUCT Ø	2000	2500	3000	3500	4000	4500	5000	5500	6000	6500	7000
3	100	125	150	170	195	220	245	270	295	320	345
4	175	220	260	305	350	395	440	485	525	570	615
5	275	340	410	475	545	615	680	750	820	885	955
6	395	490	590	685	785	885	980	1080	1180	1275	1375
7	535	670	800	935	1070	1205	1335	1470	1605	1735	1870
8	700	875	1050	1220	1395	1570	1745	1920	2095	2270	2445
9	885	1105	1325	1545	1765	1990	2210	2430	2650	2870	3090
10	1090	1365	1635	1910	2180	2455	2725	3000	3270	3545	3820
11	1320	1650	1980	2310	2640	2970	3300	3630	3960	4290	4620
12	1570	1965	2355	2750	3140	3535	3925	4320	4710	5105	5500
13	1850	2300	2770	3225	3685	4150	4610	5070	5530	5990	6450
14	2140	2675	3205	3740	4275	4810	5345	5880	6415	6950	7485
15	2450	3070	3680	4300	4900	5520	6130	6750	7360	7970	8590
16	2790	3490	4190	4885	5585	6285	6980	7680	8380	9075	9775
17	3150	3940	4730	5515	6300	7090	7880	8670	9450	10240	11030
18	3535	4420	5300	6185	7070	7950	8835	9720	10600	11485	12370
20	4365	5455	6545	7635	8725	9815	10910	12000	13090	14180	15270
22	5280	6600	7920	9240	10560	11880	13200	14520	15840	17160	18480
24	6285	7855	9425	10995	12656	14135	15710	17280	18850	20420	21995
26	7370	9210	11055	12900	14740	16580	18420	20270	22110	23950	25800
28	8550	10685	12820	14960	17100	19230	21310	23500	25650	27780	29920
30	9800	12260	14700	17170	19625	22080	24530	26990	29440	31890	34350
32	11160	13950	16750	19541	22330	25120	27910	30700	33490	36280	39070
34	12600	15755	18905	22055	25210	28360	31510	34660	37810	40965	44115
36	14130	17665	21195	24730	28260	31800	35325	38860	42390	45925	49455
38	15745	19680	23615	27550	31490	35425	39360	43295	47230	51170	55100
40	17445	21800	26170	30530	34890	39250	43610	47975	52330	56700	61055

SIZING ELBOWS & SPECIAL COMPONENTS

SIZING ELBOWS

The catalog lists the standard sizes and the standard gauges. However, Easy Duct also makes elbows in long radius and in heavier gauges. The elbows can be made in segments or can be made with smooth wall. Pricing for the various sizes and gauges should be obtained by calling Easy Duct.

SPECIAL COMPONENTS

As with the elbows, Easy Duct is able to provide special hoods or special designed pieces for almost any dust collection application. To obtain help in design or pricing, call Easy Duct.

ADAPTING TO EXISTING SYSTEMS

There will be instances where the customer will desire to apply "EASY DUCT" duct to an existing ducting system. Easy Duct makes adapters for this purpose. We can provide these in flange to "EASY DUCT" or through simply supplying "EASY DUCT" adapters that can be attached to the end of existing spiral duct so that "EASY DUCT" can be coupled to the duct.

CAULKING USED ON SEAMS OF COMPONENTS

- A) Scotch Seal (R) 2084 metal sealant.
- B) 3M ID #62-2084-2631-2
- C) Ingredients: Acetone, acrylonitrile, kaolin, phenolic resin, rosin ester salicylic acid, aluminum pigment zinc oxide, amorphous silica
- D) Paint used on Welds
Krylon Industrial Tough Coat, Acrylic Enamel # 1760 Aluminum

PAINTING GALVANIZED COMPONENTS

Step 1. Wash down all components with an industrial de-greaser, insuring that no oils or residues are left behind.

Step 2. Apply an epoxy primer in a light coating.

Step 3. For a final coat, apply an acrylic water base paint. (Example: Glidden Lifemaster)

Note: Galvaneal can be provided at additional 10% cost.

RUBBER FLEX HOSE

WHY BUY RFH HOSE:

- Wider Temperature Range
- Superior Chemical Resistance
- No Cement
- Better Abrasion Resistance
- Better Looking Product
- Better UV, Moisture and Weathering Resistance
- Outstanding Flex Resistance
- Versatility
- Air Tight
- Will Not Set to The Shape of the Box When Packed

RFH

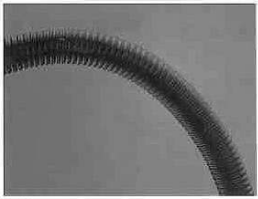

General Purpose
Part # 3280-XX00

SPECIFICATIONS:

Temperature Range: -60 F. to 275 F. (intermittent to 300 F.)

Standard Color: Black

Standard Length: 5' increments with 5' min

Sizes: 1", 1.5", 2", 2.5", 3", 3.5", 4", 5", 5.5", 6", 7", 8", 9", 10", 11", 12", 13", 14", 16", 18", 20", 24"

Description: Constructed of thermoplastic rubber and reinforced with wire helix, RFH is the most versatile general-purpose hose available today. No cements, solvents, chemicals, adhesives or glues are used in the manufacturing process of RFH. RFH has superior chemical resistance and is capable of handling fumes as tough as Methyl Ethyl Ketone, sulfuric acid or toluene. RFH is manufactured in standard black. Please consult us for minimums and prices for other lengths and on non-standard diameters, including metric sizes from 51mm to 500mm.

CVD

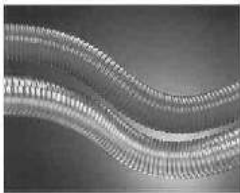

General Purpose, Economical
Part # 3280-XX00-700000

SPECIFICATIONS:

Temperature Range: -20 F to 180 F

Standard Color: Clear

Standard Length: 5' increments with 5' min

Sizes: 1", 1.5", 2", 2.5", 3", 3.5", 4", 5", 5.5", 6", 7", 8", 10", 12", 14, 16", 18"

Description: Constructed of polyvinylchloride and reinforced with steel wire, CVD is an excellent choice for many industrial and food service applications. CVD is an economical alternative to most ducts and sacrifices nothing in performance. CVD is an excellent choice for applications involving fume removal dust collection, ventilation and other more rigorous industrial requirements. Material used in clear hose is FDA acceptable.

UFD

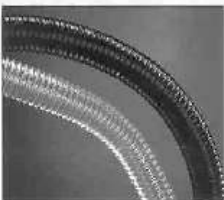

Tough or severe service applications custom part can be ordered and shipped direct.

SPECIFICATIONS:

Temperature Range: -65 F to 200 F

Standard Color: Clear or Black

Standard Length: 5' increments with 5' min

Sizes: 1", 1.5", 2", 2.5", 3", 4" 5" 6" 7" 8" 10" 12", 14", 16", 18"

Description: Constructed of thermoplastic urethane and reinforced with a wire helix, UFD offers superior abrasion resistance. UFD is the answer for those who want a lightweight, flexible hose which can handle much abrasion. UFD can be used in numerous applications such as leaf loading, chip handling, dust collection, etc. The superior transparency of the clear UFD allows users to locate blockages. This hose is suitable for severe service applications including vacuum and high abrasion. Material used in clear hose is FDA acceptable.

RIGID & ULTRA FLEX METAL HOSE

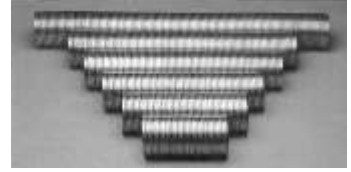

RIGID METAL FLEX HOSE

PART # 3281-XX00

Inside Dia. (Inches)	Approx. Outside Dia. (Inches)	Min. CLR Bend Radius	Approx. Weight Per Foot (LBS)
1 1/2	1 3/4	12.0	1.00
2	2 1/4	16.0	1.30
2 1/2	2 3/4	18.0	1.60
3	3 1/4	22.0	2.00
3 1/2	3 3/4	25.0	2.30
4	4 1/4	29.0	2.60
5	5 1/4	34.0	3.00

MEDIUM-HEAVY GALVANIZED OR STAINLESS

Inside Dia. (Inches)	Approx. Outside Dia. (Inches)	Min. CLR Bend Radius	Approx. Weight Per Foot (LBS)
6	6 1/4	44.0	3.60
7	7 1/4	50.0	4.20
8	8 1/4	56.0	4.70
9	9 1/4	61.0	5.30
10	10 1/4	65.0	5.90
12	12 1/4	76.0	7.00
14	14 1/4	106.0	8.10

.017- .020 Strip Thickness

ULTRA FLEX METAL HOSE

PART # 3283-XX00

Inside Dia. (Inches)	Min. CLR Bend Radius	Approx. Weight Per Foot (LBS)
3	21	2.15
4	30	2.65
5	35	2.95

Manufactured in sizes ranging from 3" dia thru 8" dia of stainless steel or galvanized. Some applications would include air handling, and dust collection.

Inside Dia. (Inches)	Min. CLR Bend Radius	Approx. Weight Per Foot (LBS)
6	43	3.55
7	52	4.15
8	60	4.55

Square Lock: ID Tolerance: +1/4" , - 0
 Specification: 3"-6" manufactured out of .019 material
 7"-8" manufactured out of .024 material

RIGID AND ULTRA FLEX STEEL HOSE CONFIGURATIONS

STEEL FLEX HOSE WITH RAW ENDS (STANDARD)

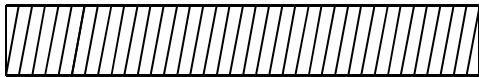

STEEL FLEX HOSE WITH EASY DUCT ENDS (CUSTOM)



STEEL FLEX HOSE WITH FLANGE ENDS (CUSTOM)

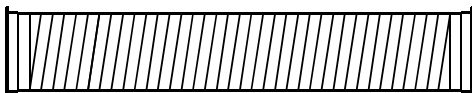

STEEL FLEX HOSE WITH RAW PIPE ENDS (CUSTOM)

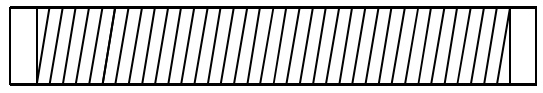

NOTE: When ordering steel hose, you have the option of having the hose fitted with several different style end fittings in any number of combinations. Raw hose is priced per foot, and sold only in 5 Ft. increments. Contact your sales rep for pricing on specific lengths and end fittings.

BLEED-IN VALVE

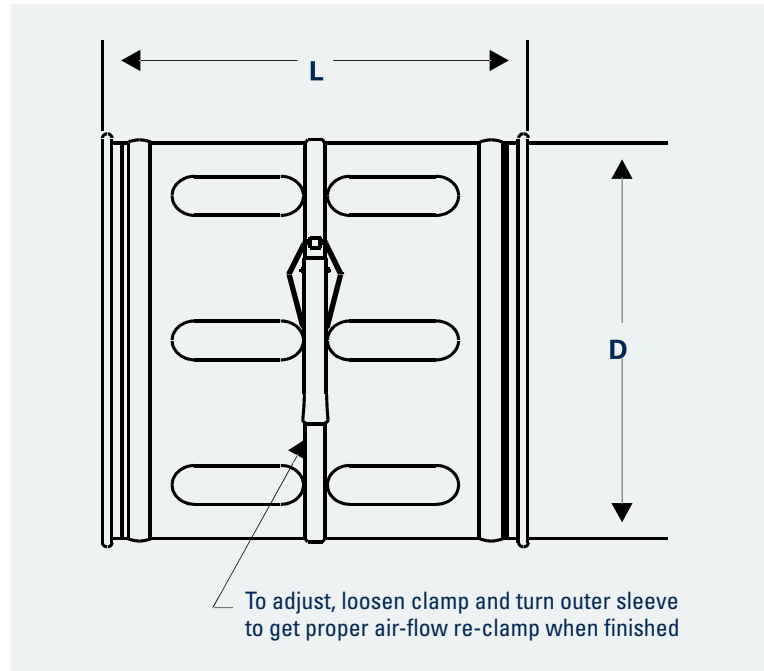

Diameter "D"	Length	No. Slots Per Row	Gauge
4"	11"	2	22
5"	11"	3	22
6"	11"	3	22
7"	11"	4	22
8"	11"	4	22
9"	11"	5	22
10"	11"	5	22
11"	11"	6	22
12"	11"	6	22

Diameter "D"	Length	No. Slots Per Row	Gauge
13"	11"	6	20
14"	11"	7	20
15"	11"	6	20
16"	11"	8	20
17"	11"	9	20
20"	11"	10	20
22"	11"	11	20
24"	11"	11	20

DESCRIPTION:

A slotted movable band over slotted "EASY DUCT" duct, allowing for adjustment of airflow.

APPLICATIONS:

Used to adjust airflow to balance system by introducing ambient air.

AVAILABILITY:

Material: GALVANIZED or STAINLESS STEEL

Sizes in inch: 4, 5, 6, 7, 8, 9, 10, 11, 12, 13, 14, 15, 16, 17, 18, 20, 22, 24

Part numbers: 3207-XX00 (where XX is the diameter)

INSTALLING TAP-IN OR CUT-IN

STEP 1:

Temporarily place the in-cut on the main trunk in the required position, and while holding in place, place hand inside of branch and trace the interior of the branch on trunk line where it needs to be cut out.

STEP 2:

Take down in-cut and drill a starter hole in the main trunk along the line traced from the branch. Then using metal snips or a reciprocating saw, cut out metal piece that has been traced. File or grind any sharp edges to insure efficient flow.

STEP 3:

Now use an industrial strength silicone sealant to seal between in-cut base and main trunk.

STEP 4:

Use small sheet metal screws or a banding type clamp material to secure in-cut to the main trunk line.

IN-CUT

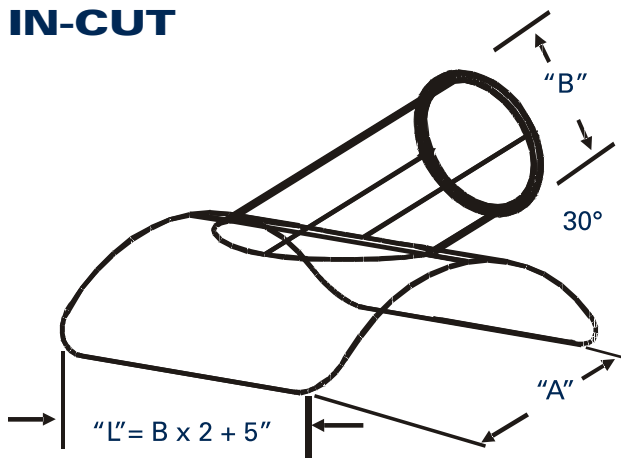

TAP-IN

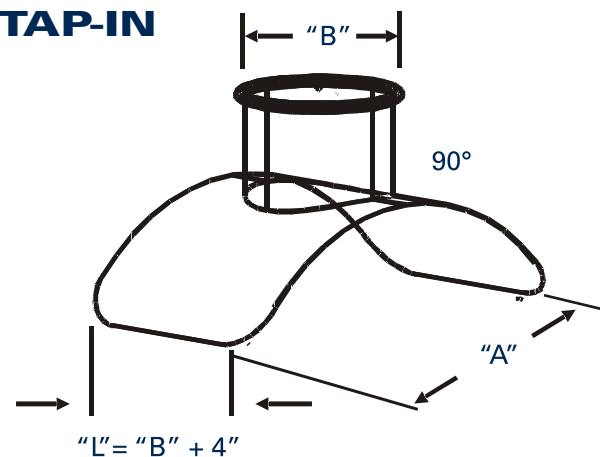

AUTOMATIC BLAST GATE

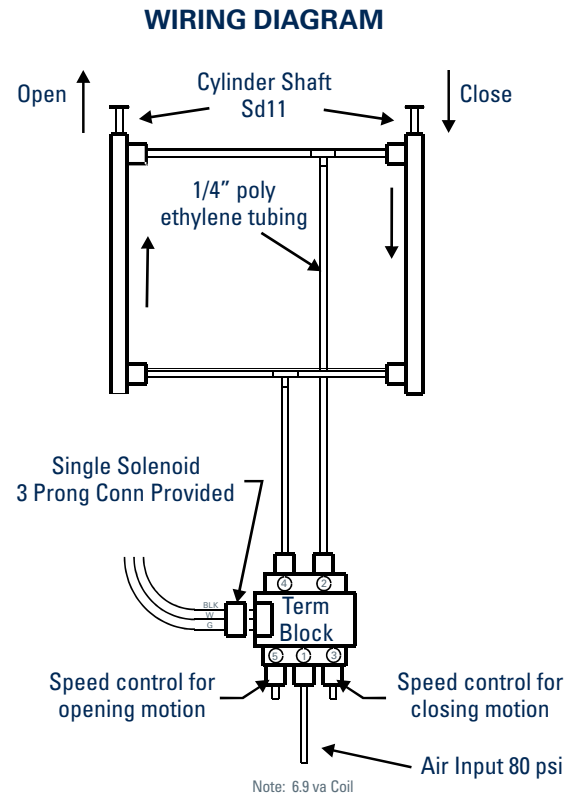
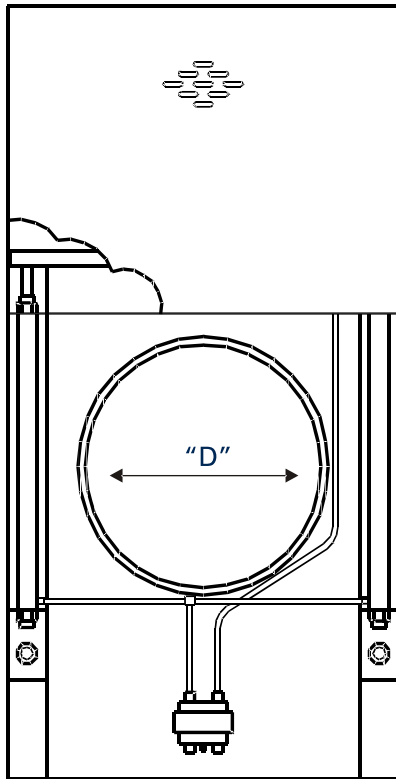

DESCRIPTION

Automatic energy saving blast gates operated by double-acting compressed air cylinders. Cylinders are controlled by electrically-connecting solenoid to machines or remote switch. Gates are constructed with a special sealing device that reduces air loss and friction in operation.

APPLICATIONS

Gates are used as energy-saving devices for industrial dust extraction where extraction is not always needed and where manual control needs to be eliminated.

AVAILABILITY:

Material: GALVANIZED or STAINLESS STEEL

Sizes in inch: 4, 5, 6, 7, 8, 9, 10, 11, 12, 14, 16, 18, 20, 22, 24, 26

Part numbers: 3245-XX00 (where XX is the diameter)

Special: Customer needs 120 Volt and 50 psi minimum air pressure. 240, 24 and 12 volt AC as well as 24 and 12 volt DC models are available upon request.

MANUAL BLAST GATE

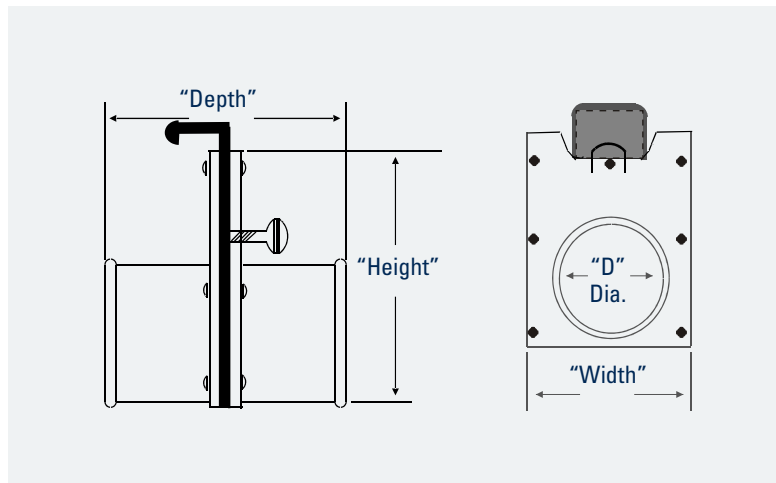

Manually operated, cast aluminum body with standard Easy Duct connection unless otherwise specified.

DIA. (D) INCHES	PART NO.	WIDTH	HEIGHT	DEPTH	COLLAR HEIGHT	WT LBS.
4"	3240-04	5.25	7.00	5.750	2.650	2.0
5"	3240-05	6.12	6.25	5.750	2.550	3.0
6"	3240-06	7.00	10.00	5.750	2.500	3.5
7"	3240-07	8.00	11.12	5.375	2.375	4.5
8"	3240-08	9.37	12.00	5.375	2.375	5.5
9"	3240-09	11.00	13.25	5.500	2.370	7.0
10"	3240-10	11.37	14.37	5.500	2.370	8.0
11"	3240-11	13.50	16.25	5.000	2.250	12.0
12"	3240-12	13.50	16.25	5.000	2.250	12.0
14"	3240-14	15.75	17.87	5.000	2.250	16.0
16"	3240-16	18.00	28.50	11.000	2.250	20.0
18"	3240-18	20.80	32.75	11.000	5.250	37.0
20"	3240-20	22.25	34.00	11.000	5.125	45.0
22"	3240-22	24.25	33.50	11.000	5.125	48.0
24"	-	-	-	-	-	CALL

ENERGY SAVING BLAST GATE

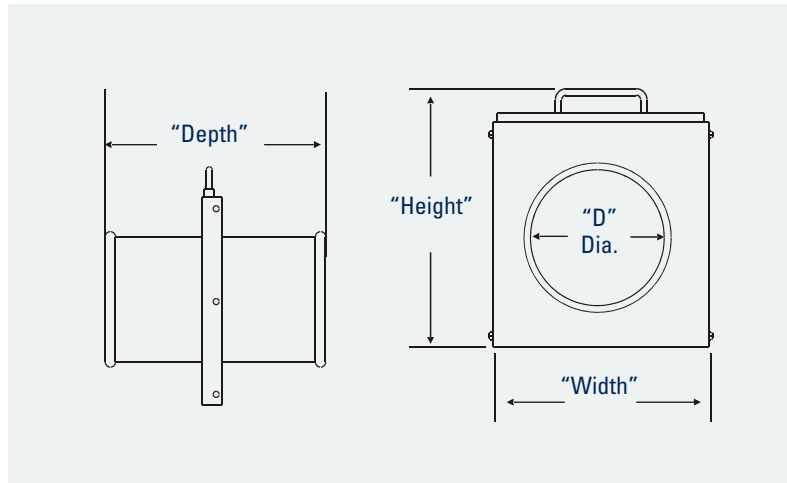

Manually operated, energy saving blast gates. These compact and easy to operate gates are constructed of galvanized metal with a special sealing device that reduces air loss and friction in operation.

DIA. (D) INCHES	PART NO.	WIDTH	HEIGHT	DEPTH	COLLAR HEIGHT	WT LBS.
4"	3241-04	5.25	7.00	5.75	2.65	2.0
5"	3241-05	6.12	6.25	5.75	2.55	3.0
6"	3241-06	7.00	10.00	5.75	2.50	3.5
7"	3241-07	8.00	1.12	5.375	2.375	4.5
8"	3241-08	9.37	12.00	5.375	2.375	5.5
9"	3241-09	11.00	13.25	5.50	2.37	7.0
10"	3241-10	11.37	14.37	5.50	2.37	8.0
12"	3241-12	13.50	16.25	5.00	2.25	12.0
14"	3241-14	15.75	17.87	5.00	2.25	16.0
16"	3241-16	18.00	28.50	11.00	5.25	20.0

DIVERTER VALVE

AUTOMATIC

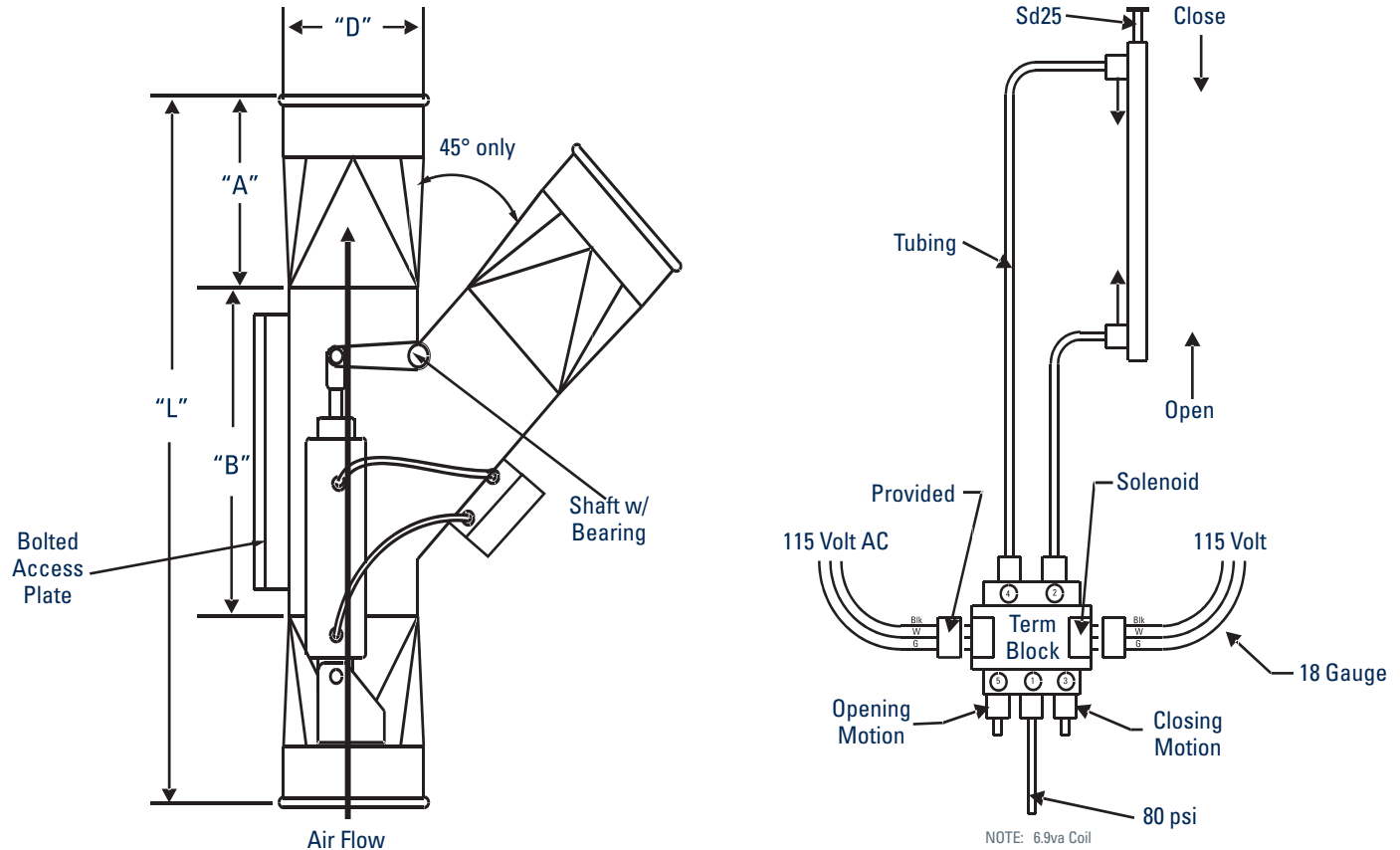

DESCRIPTION

Highly efficient, economical method of diverting flow of material or air. Designed with Q-F or flanged, manual, or air operated.

APPLICATIONS

Diverter valves are used for diverting the air to one of two possible directions at a time. Divert the flow of material or air.

AVAILABILITY

Material: BLACK METAL or STAINLESS STEEL 3/16" thick

Sizes in inch: 3, 4, 5, 6, 7, 8, 9, 10, 11, 12, 13, 14, 15, 16, 17, 18, 20, 22, 24

Larger sizes available upon request.

Please NOTE: 45 lateral angle only

Part numbers: 3235-XX00 for manual (where XX is the diameter)

3236-XX00 for automatic, PLUS read "Special".

Special: Customer needs 120Volt and 75 psi minimum air pressure.

240, 24 and 12 volt AC as well as 24 and 12 volt DC models are available upon request.

WALL & ROOF FLASHING

WALL FLASHING

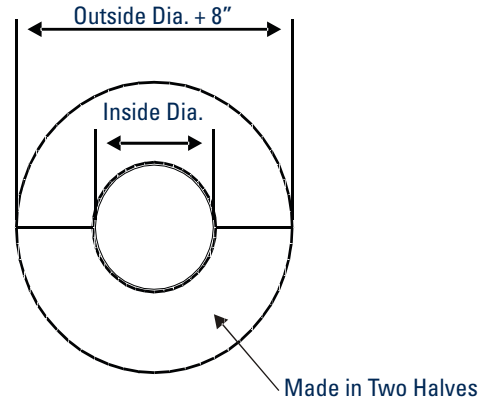
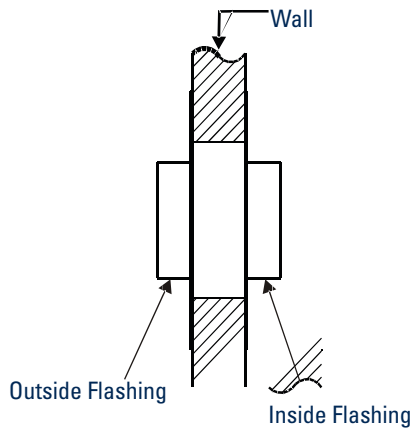

DESCRIPTION:

Provides weather protection for wall penetration. Ordering "one flashing" provides you with both one inside and one outside flashing (4 halves).

AVAILABILITY:

Material: GALVANIZED or STAINLESS STEEL
 Sizes in inch: 4, 5, 6, 7, 8, 9, 10, 11, 12, 13, 14, 15, 16, 17, 18, 20, 22, 24, 26, 28, 30, 32, 34, 36, 38, 40

ROOF FLASHING

ELEVATION VIEW

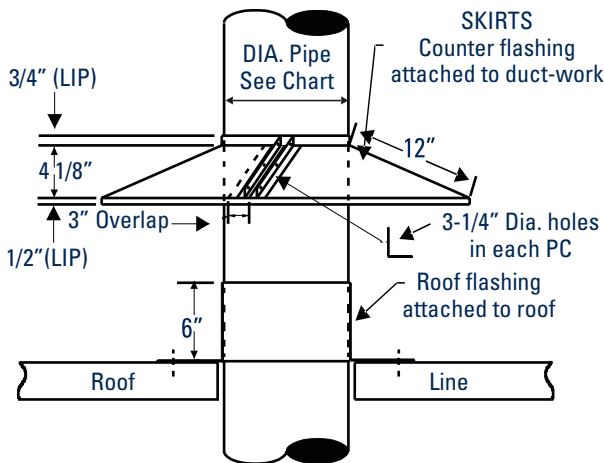

TOP VIEW

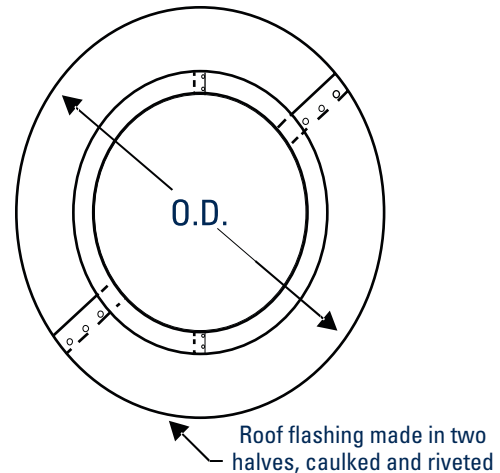

DESCRIPTION:

Provides weather protection for roof penetration.

AVAILABILITY:

Material: GALVANIZED or STAINLESS STEEL
 Sizes in inch: 4, 5, 6, 7, 8, 9, 10, 11, 12, 13, 14, 15, 16, 17, 18, 20, 22, 24, 26, 28, 30, 32, 34, 36, 38, 40

QUANTITY	DIA. OF PIPE NEW LASER WELD SEAM	# OF SETS

NOTE: Please specify Wall or Roof Flashing

WALL MOUNTING BRACE

TYPICAL WALL MOUNTING BRACE

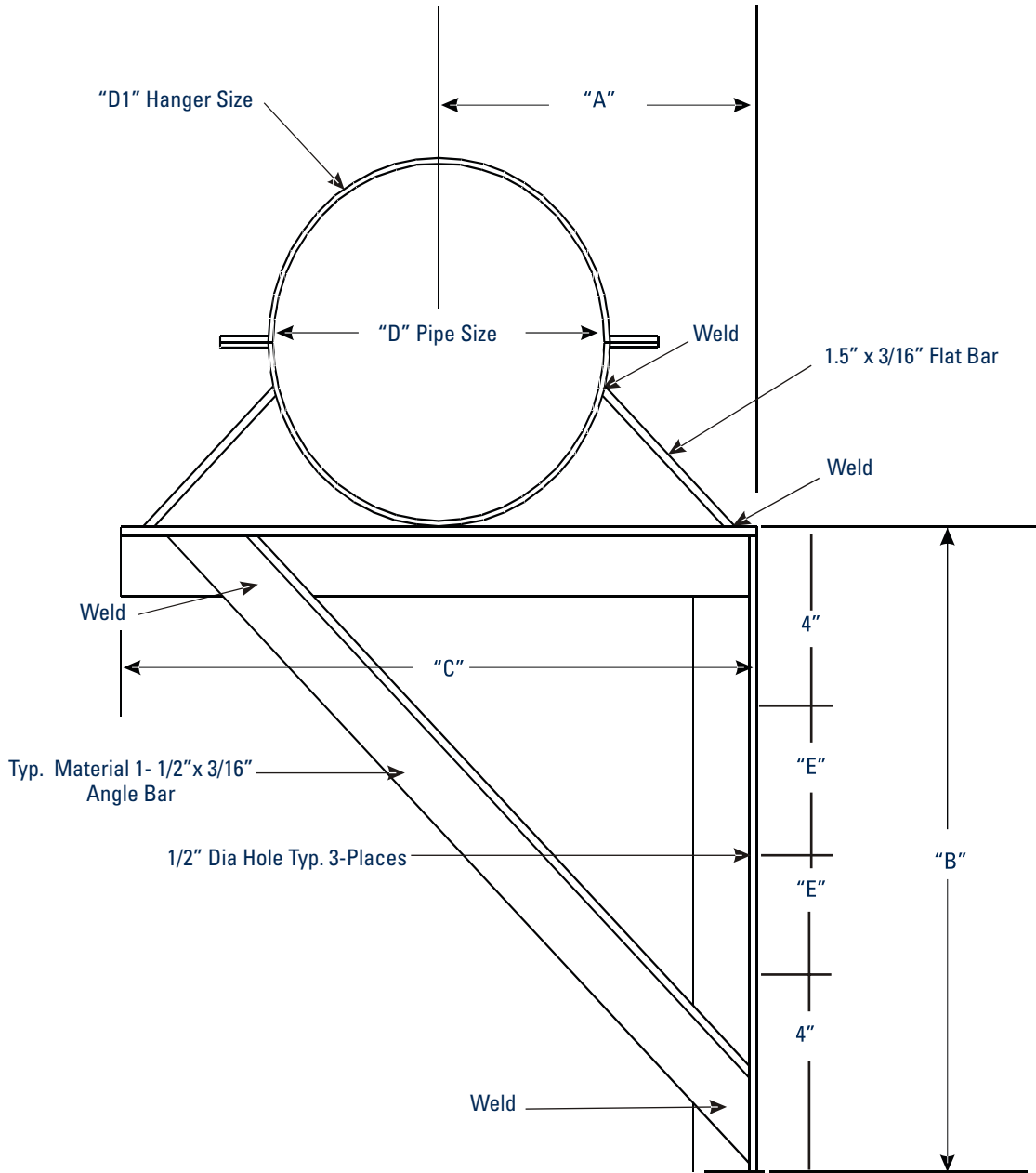

QTY	"A"	"B"	"C"	"D1"	"D"	"E"

CEILING HANGING METHOD

TYPICAL CEILING HANGING METHOD

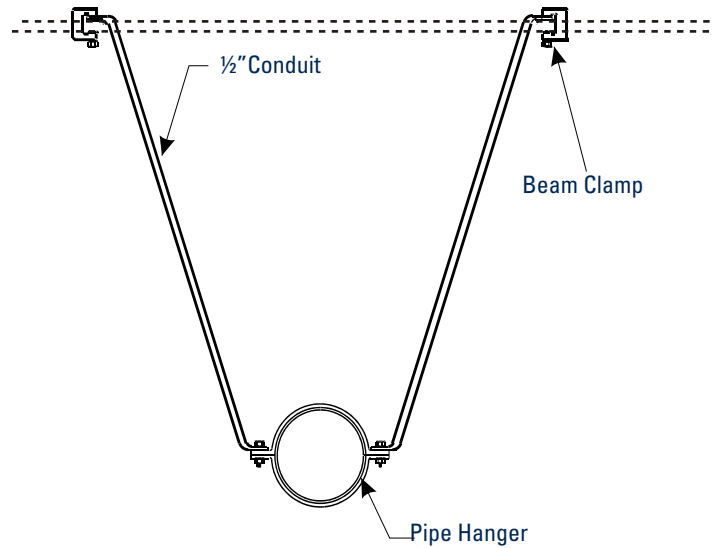
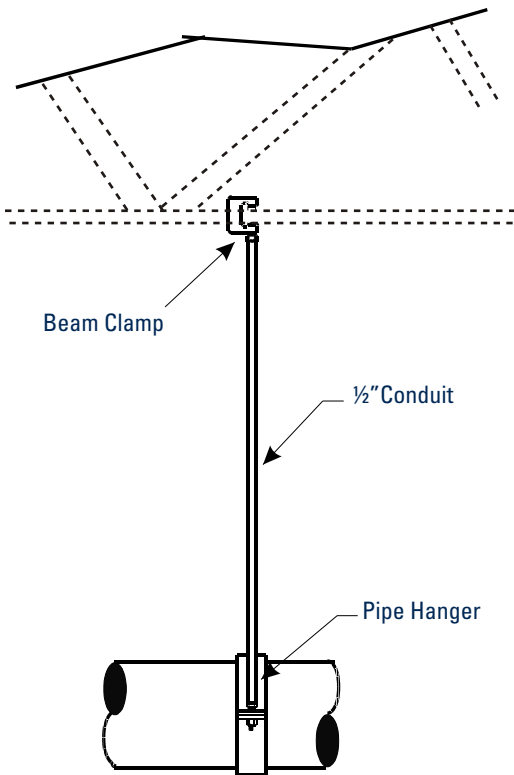
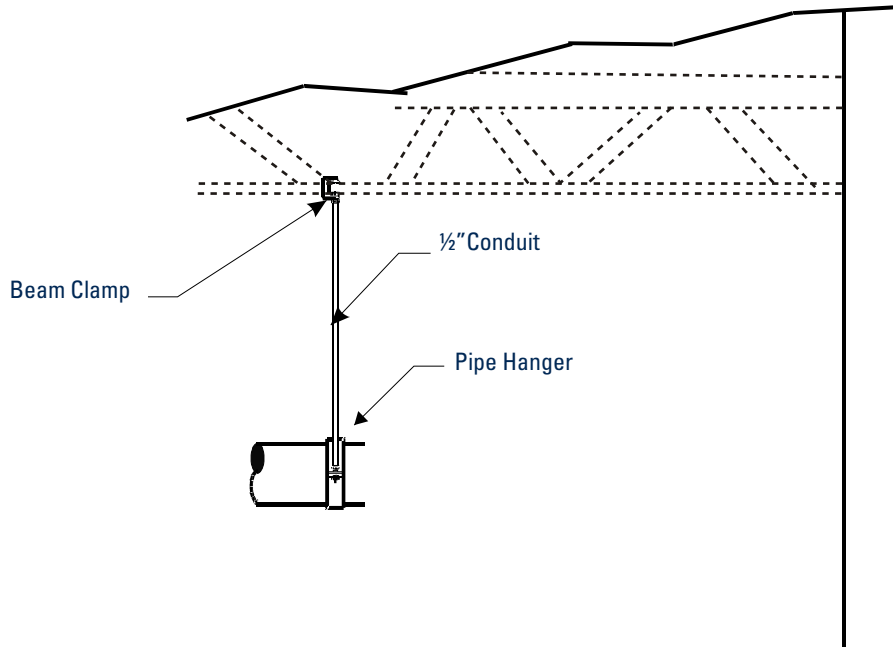

NOTE:
 1. Above 10" should be supported approximately every 15' to 20' from roof joist.
 2. Below 10" should be supported approximately every 12' to 15' from roof joist.

PIPE STAND WITH HANGER BRACKET

SPECIAL PIPE STAND HANGER BRACKET

MATERIAL: 1 1/4" X 3/16" BLK FLAT BAR PAINT TO MATCH GREY STAND

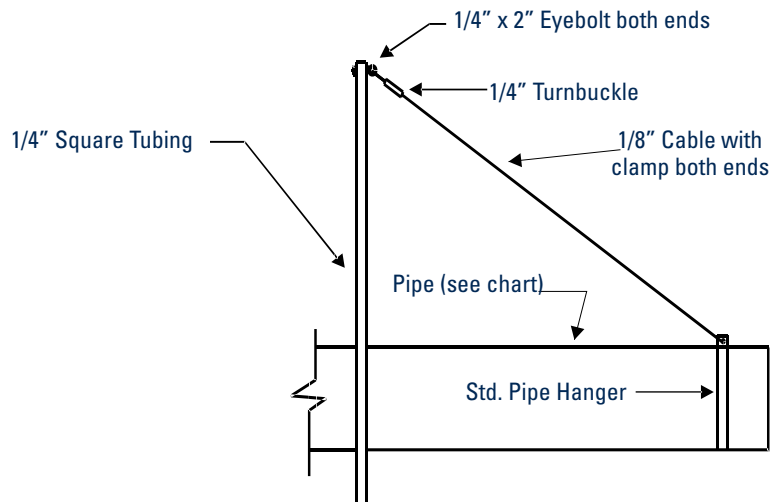
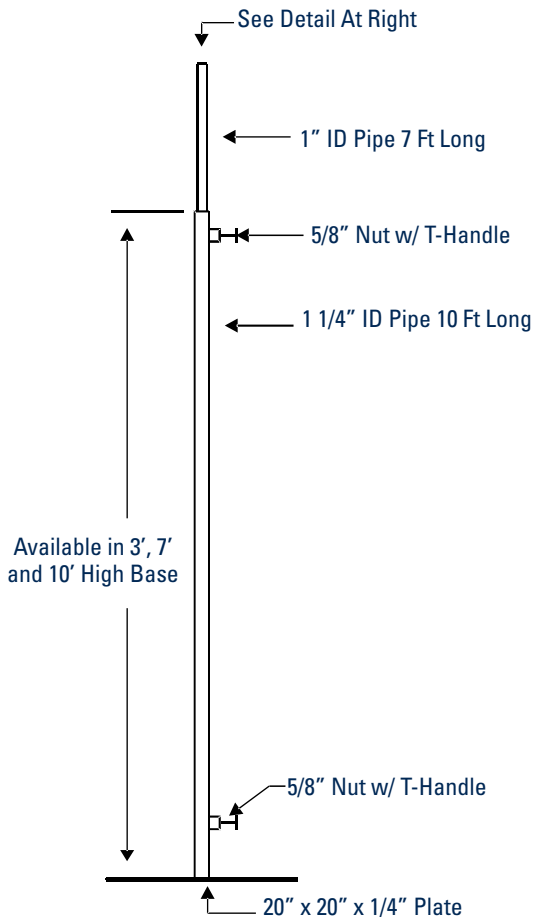
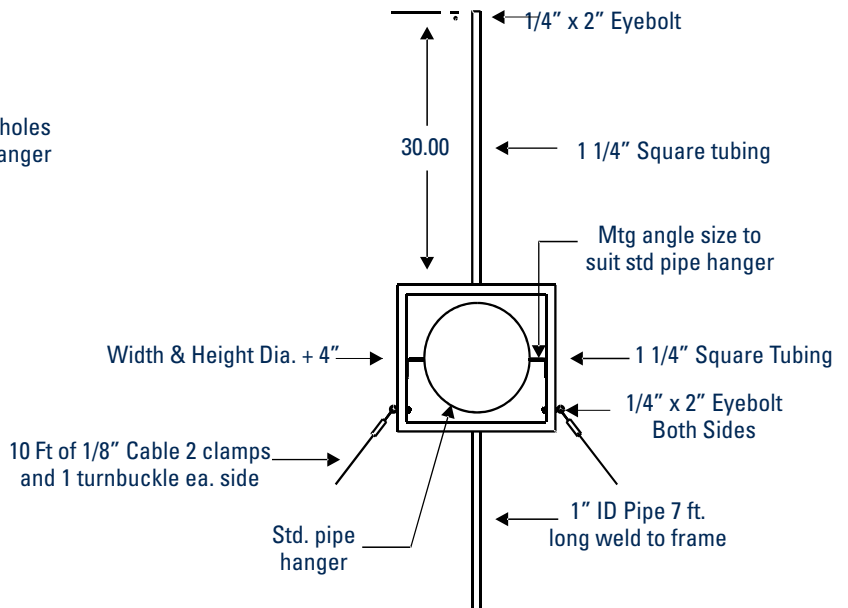
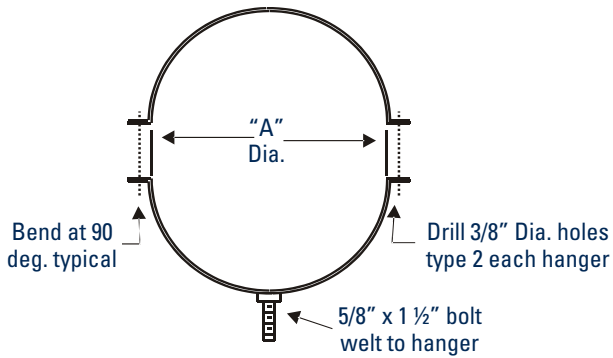

Note: This special type of pipe stand and hanger are used in certain situations, such as at trade shows and tight installations.

GRIPPLE HANG-FAST

GRIPPLE HANG-FAST

Gripple Hang-Fast is a complete solution for hanging mechanical and electrical services. It comes as a ready-to-use suspension kit, with load ratings from 35 kg to 325 kg. The comprehensive range ensures that installation times are minimized and high productivity is achieved on site.

The principal element of all Gripple Hang-Fast assemblies is the Gripple Hang-Fast Grip, which is not only used to terminate the rope but is also the means by which object height can be adjusted.

GRIPPLE HANG-FAST SIZES & WORKING LOAD LIMITS

ITEM #	LENGTH	WEIGHT	AVAILABILITY
3266-1500-022LBS	15'	22 LBS	IN STOCK
3266-1500-100LBS	15'	100 LBS	IN STOCK
3266-1500-200LBS	15'	200 LBS	IN STOCK
3266-1500-495LBS	15'	495 LBS	IN STOCK
3266-1500-715LBS	15'	715 LBS	IN STOCK

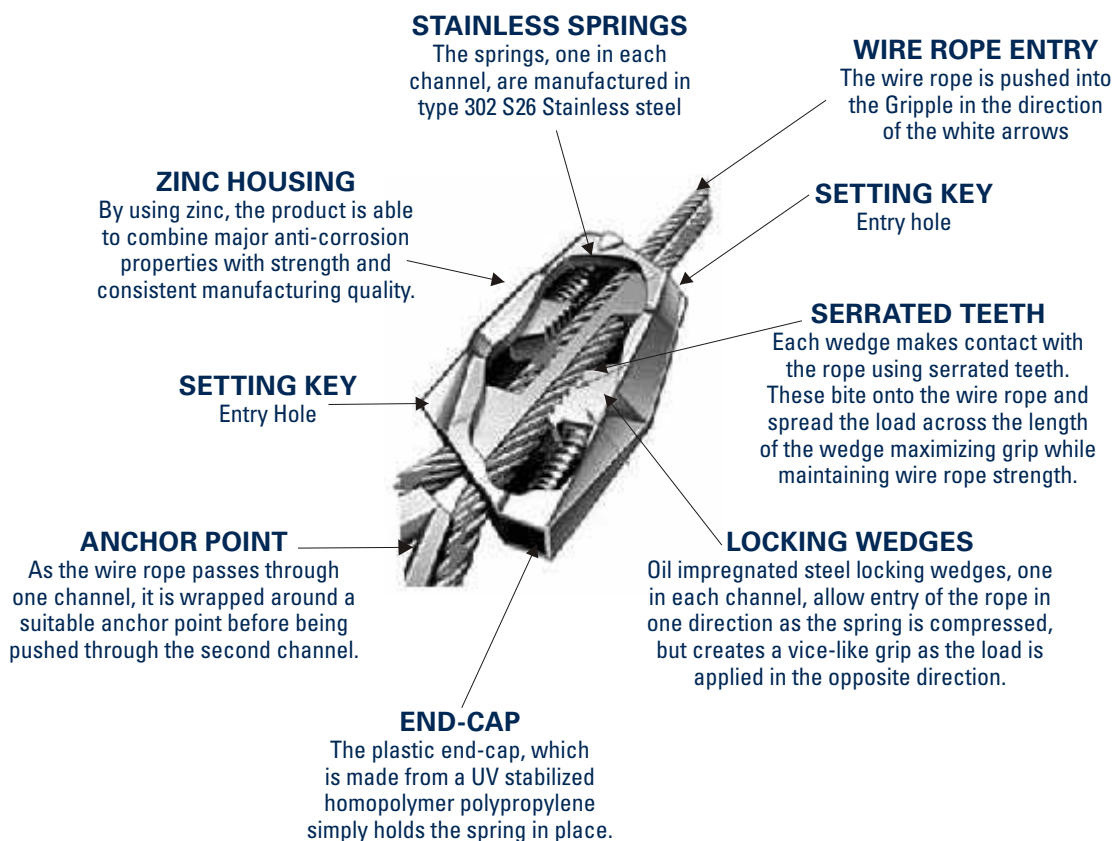

NO-LOSS STACK-HEAD

DESCRIPTION

Used when exhausting from fans or stacks through the roof.

AVAILABILITY

Material: GALVANIZED or STAINLESS STEEL

Sizes in inch: 3, 4, 5, 6, 7, 8, 9, 10, 11, 12, 13, 14, 15, 16, 17, 18, 19, 20, 21, 22, 23, 24, 26, 28, 30, 32, 34, 36, 38, 40

Part numbers: 3204-XX00 (where XX is the diameter)

APPLICATIONS

Eliminates back pressure on the fan while providing weather protection.

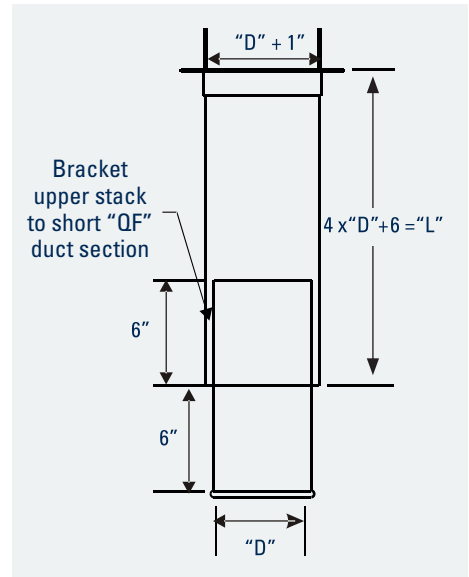

INLINE SILENCER

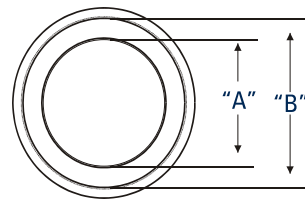
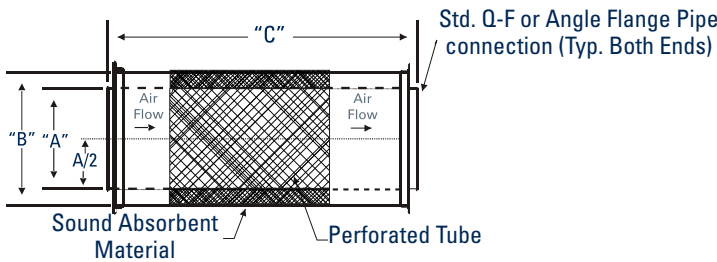

"A"	"B"	PART NO.	ENDS	LENGTH (C)	GAUGE HOUSING	WEIGHT (GALV)
3"	12"	3106-0300	QF	28"	16	10.00
4"	12"	3106-0400	QF	28"	16	21.00
5"	13"	3106-0500	QF	28"	16	35.00
6"	14"	3106-0600	QF	30"	16	43.00
7"	15"	3106-0700	QF	30"	16	54.00
8"	16"	3106-0800	QF	35"	16	65.00
9"	17"	3106-0900	QF	40"	16	76.00
10"	18"	3106-1000	QF	48"	16	89.00
12"	20"	3106-1200	QF	54"	16	104.00
14"	22"	3106-1400	QF	60"	16	122.00
16"	24"	3106-1600	QF	64"	16	176.00
18"	26"	3106-1800	QF	68"	16	225.00
20"	28"	3106-2000	QF	72"	16	265.00
22"	30"	3106-2200	QF	76"	16	310.00
24"	32"	3106-2400	QF	80"	16	406.00
26"	34"	3106-2600	FLANGE	80"	16	546.00
28"	36"	3106-2800	FLANGE	80"	16	600.00
30"	38"	3106-3000	FLANGE	80"	16	678.00
32"	40"	3106-3200	FLANGE	80"	16	700.00
34"	42"	3106-3400	FLANGE	80"	16	770.00
36"	44"	3106-3600	FLANGE	80"	16	897.00
38"	46"	3106-3800	FLANGE	80"	16	974.00
40"	48"	3106-4000	FLANGE	80"	16	1,118.00

1. Silencer to be placed in process line down stream of fan or cyclone collector.
2. Silencer housing constructed of 16 gauge galvanized metal.
3. Silencer should be properly supported in process line.
4. NORDFAB reserves the right to modify the design of the silencer without notice.
5. Efficiencies of Silencer have not been tested, nor are there any guarantees of sound level attenuation.
6. Silencer made in two sections for 16" & larger diameters.

LABOR GUIDELINES

RULE OF THUMB LABOR GUIDELINES

A) Long straight runs and trunk-lines

- “EASY DUCT” duct = 6 to 10 man hours per 100’
- Flanged duct = 20 man hours per 100’

B) Machine Connections

- Machine with 1 or 2 ports = 1.5 to 3 man hours per port
- Machines with 3 or more ports = 4 man hours per port

A + B = TOTAL MAN HOURS
OR
QUICK METHOD

(TOTAL # OF PORTS) X 3 HOURS EACH = “X”
“X” X 2 = DUCTING SYSTEM TOTAL MAN HOURS

NOTE: The above methods should be used for comparison and budgetary purposes only. By no means should they be used to confirm a job installation. It should be the sales person's responsibility to analyze each individual job and make his/her own judgement.

THINGS TO BE AWARE OF WHEN ORDERING “EASY DUCT”

1. Order one clamp per “EASY DUCT” component.
 - 1 - duct = 1 clamp
 - 2 - elbows = 2 clamps
2. Specify dimensional information to speed up process:
 - Transitions A,B,D,L,X,Y and flange style
 - Branches A x B x C, or A x B x D, or A x B x C x D
 - Tap-In or In-cuts A, B
 - Reducer All diameters and end style

THERE IS NO SUCH THING AS TOO MUCH INFORMATION

3. Look for 60 degree elbows to compliment branch orders. This is typical application since the two components will create a perpendicular run to the trunk line.
4. Ask for flange styles, hole patterns, ID, OD, when applicable. Typical components requiring flanges will be parts that connect to filters, fans or other types of equipment.

HIGH-TEMP FUME OR EXHAUST APPLICATIONS

HIGH-TEMP FUME OR EXHAUST APPLICATIONS

GALVANIZED

Ducting will accommodate systems 0 degrees to 500 degrees F. with little or no breakdown of the zinc coating. Zinc melting point is 740 degrees F.

304 SS

Ducting will accommodate systems 500 degrees F. to 1100 degrees F. with no problems. At temperatures above 800 degrees, a small amount of "bluing" may occur.

CLAMP GASKETING ALTERNATIVES

1. Nitrile gasket - standard
 - Service temperature: -104 deg to +158 deg with an intermittent max temp of +194 deg.
 - Standard seal installed in clamp
 - The standard specifications meet ASTM D 1056.
 - 3/8" gasket for 4",5",6"
 - 1/2 " gasket for 7" and larger
2. Inertech PTFE gasket tape
 - Service temperature -450 DEG F. to 600 DEG F
 - FDA suitable for use in food and pharmaceutical industries
 - Not degraded by any common chemicals [0-14 PH range]
 - Non-contaminating and non-aging
 - 3/8" gasket for 4",5",6"
 - 1/2" gasket for 7" and larger

TEMPERATURE RATINGS

1. Black rubber O-Ring material
Service temperature:
 - -40 DEG F. to 250 DEG F.
 - 70 Duro-meter hardness
2. Red rubber silicon O-Ring material
Service temperature: -100 DEG F. TO 500 DEG F.
 - FDA suitable for use in food and pharmaceutical industries
 - Specification: ZZ-R-765 Class 2A and 2B Grade 70 AMS-3304E and 3304F and 3303G
3. Diverter gasket 200 DEG F.
4. (RFH) rubber hose 275 DEG F.
5. UHMW seals in blast gates 180 DEG F.
6. Teflon seals 300 DEG F.
7. Galvanized ducting 500 DEG F.
8. Stainless steel ducting 800 DEG F.
9. RTV high temperature caulk 500 DEG F.
10. Standard caulk up to 250 DEG F.

NOTE: For temperatures 250 degrees F. to 500 degrees F. please request RTV High temp silicone caulk on components. There will be a 10% extra charge.

WET SYSTEM INSTALLATION

TYPICAL DROP FOR WET SYSTEMS

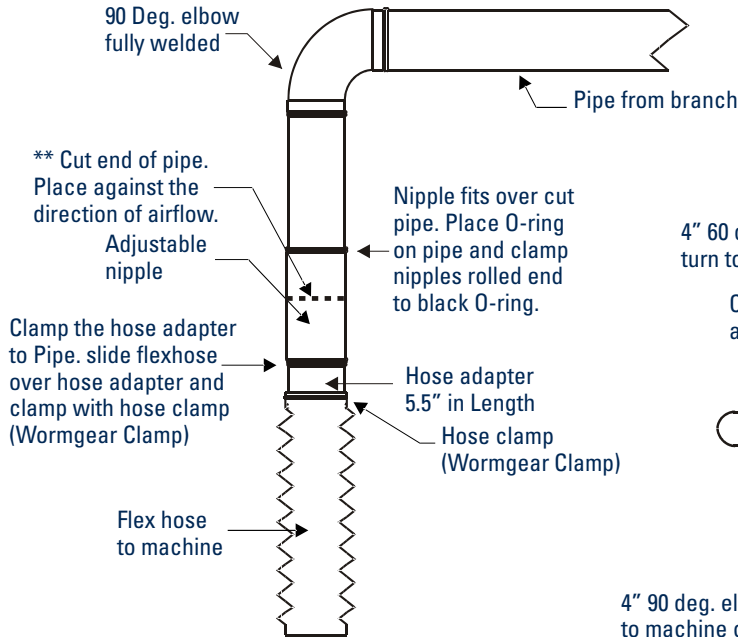

ELEVATION VIEW

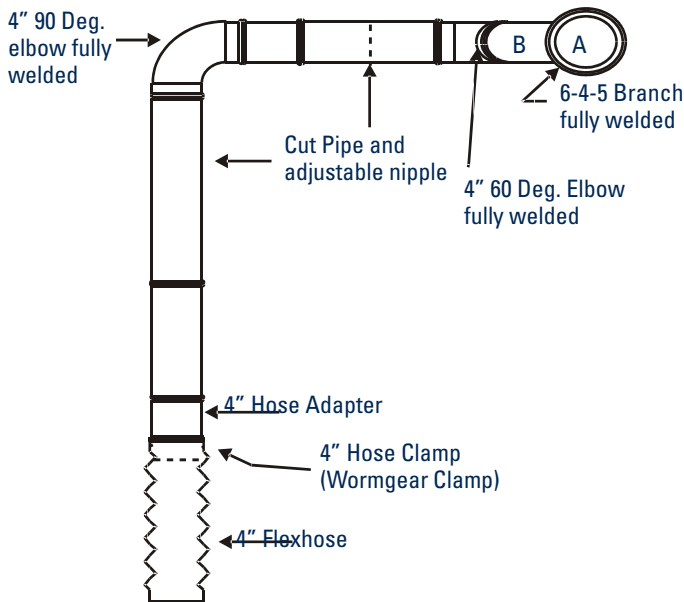

PLAN VIEW

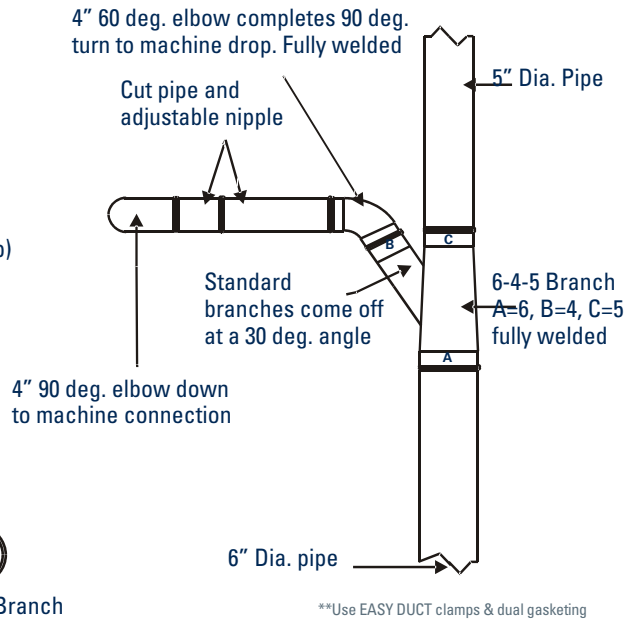

HARD DUCT TO MACHINE

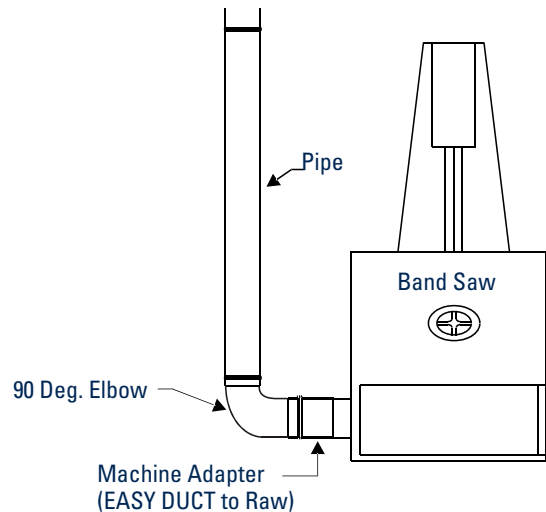

NOTE: Blast gates are not commonly used for wet systems. Use butterfly valves for flow control.
 ** Use EASY DUCT clamps & dual gasketing

DRY SYSTEM INSTALLATION

TYPICAL DROP FOR DRY SYSTEMS

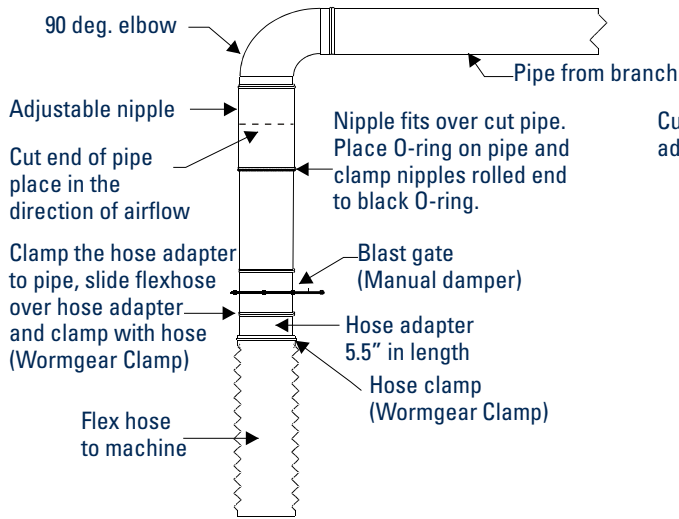

PLAN VIEW

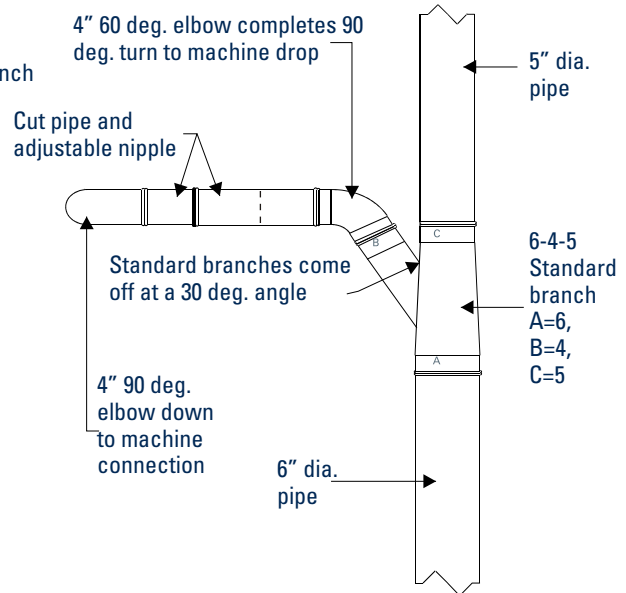

ELEVATION VIEW

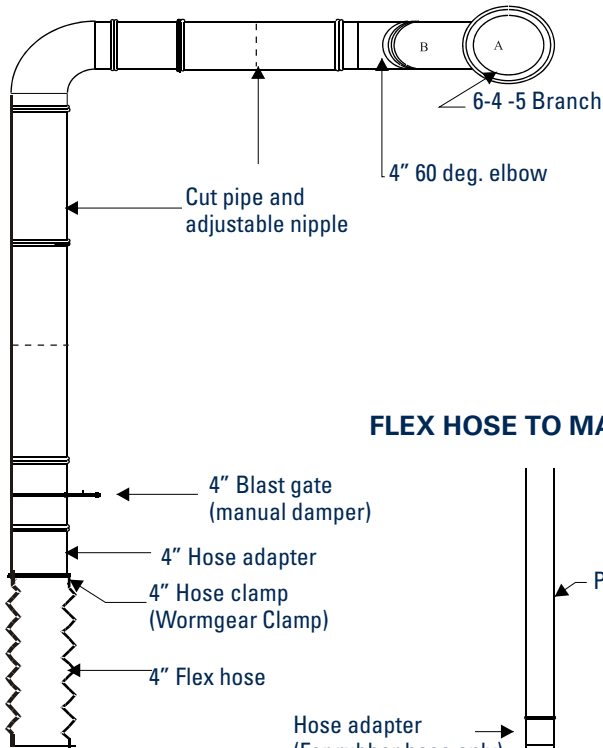

HARD DUCT TO MACHINE

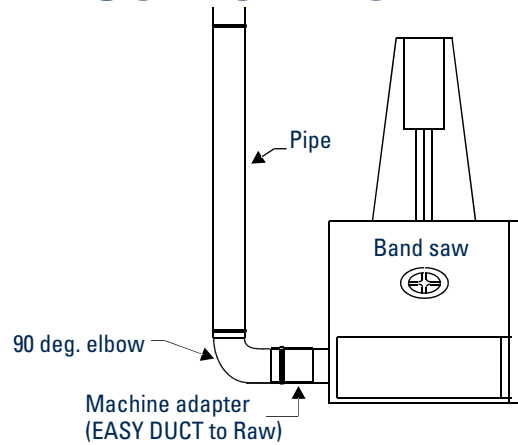

FLEX HOSE TO MACHINE

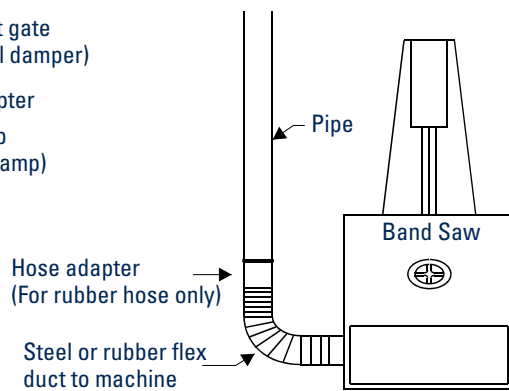

BRANCH STYLES

BRANCHES STANDARD

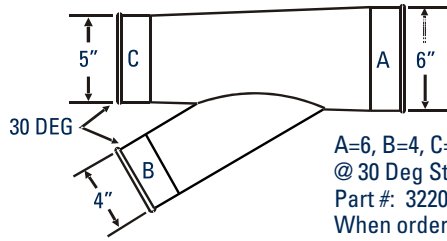

A=6, B=4, C=5
 @ 30 Deg Standard
 Part #: 3220-06xx.
 When ordering, provide part # and description.
Examples:
 3220-06 6-4-5
 or Branch 6-4-5

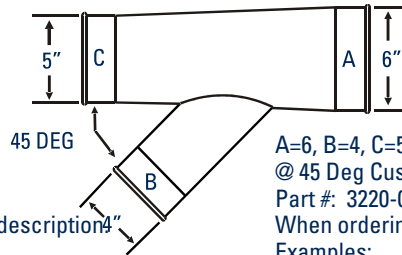

A=6, B=4, C=5
 @ 45 Deg Custom
 Part #: 3220-06xx.
 When ordering, provide part # and description.
Examples:
 3220-06 6-4-5 @ 45 Deg
 or Branch 6-4-5 @ 45 Deg

DOUBLE BRANCHES

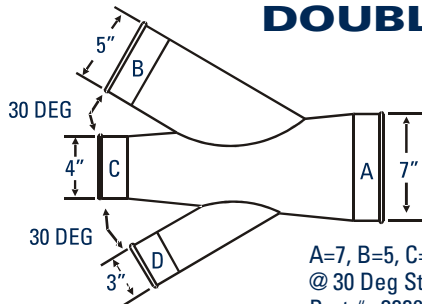

A=7, B=5, C=4, D=3
 @ 30 Deg Standard
 Part #: 3226-07xx.
 When ordering, provide part # and description.
Examples:
 3226-07 7-5-4-3
 or Double Branch 7-5-4-3

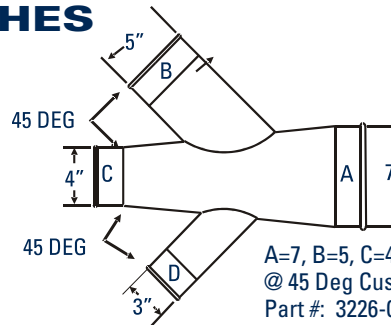

A=7, B=5, C=4, D=3
 @ 45 Deg Custom
 Part #: 3226-07xx.
 When ordering, provide part # and description.
Examples:
 3226-07 7-5-4-3 @ 45 Deg or Double Branch
 7-5-4-3 @ 45 Deg

Y-BRANCHES

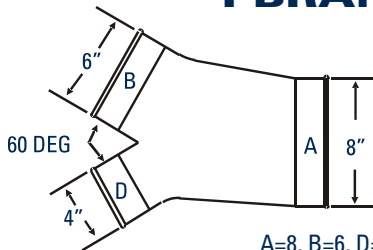

A=8, B=6, D=4
 @ 60 Deg Standard
 Part #: 3221-08xx.
 When ordering, provide part # and description.
Examples:
 3221-08 8-6-4
 or Y- Branch 8-6-4

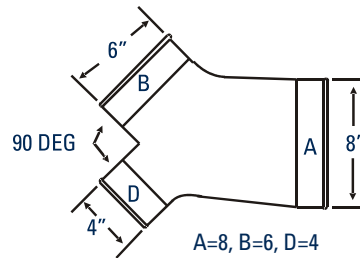

A=8, B=6, D=4
 @ 90 Deg Custom
 Part #: 3221-08xx.
 When ordering, provide part # and description.
Examples:
 3221-08 8-6-4 @ 90 Deg
 or Y- Branch 8-6-4 @ 90 Deg

T-BRANCHES

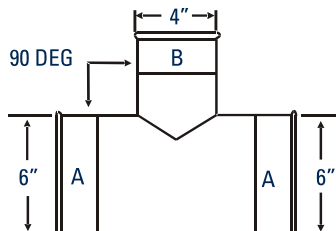

A=6, B=4
 @ 90 Deg Standard
 Part #: 3227-0604. When ordering, provide part # and description.
Examples:
 3227-0604
 or T- Branch 6-4

REDUCER STYLES

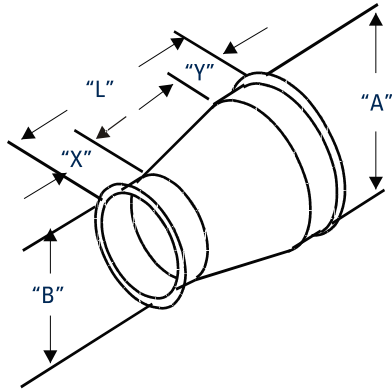

"EASY DUCT STYLE"

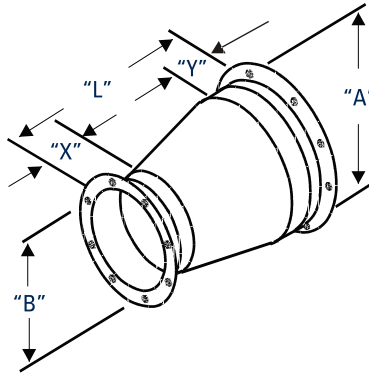

"FLANGED STYLE"

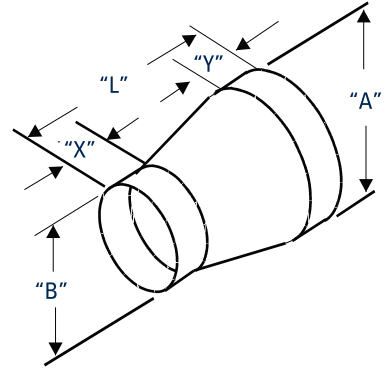

"RAW END STYLE"

A) Reducers are produced by the following formula:

"EASY DUCT" LENGTH = (A-B) + 6" [7" MIN]

"FL" LENGTH = (A-B) + 8" [9" MIN]

B) Material gauges as follows:

DIA.	GALV. GAUGE	SS GAUGE
4" - 12"	22	22
14" - 22"	20	20
24" - 40"	18	18

NOTE: Any combination of the above style are available upon request. Please specify all the required dimensions and all reducer end configurations (Raw ID, Raw OD Style, EASY DUCT Style, Flange Style, Etc.)

Item#	Qty	"A"	Style "EASY DUCT" "Flange" "Raw"	"B"	Style "EASY DUCT" "Flange" "Raw"	"L" (A-B+6)	"X" STD-2"	"Y" STD-2"	Part Gauge	Flange Material	Flg Dwg	Special Notes

SIZING BRANCHES

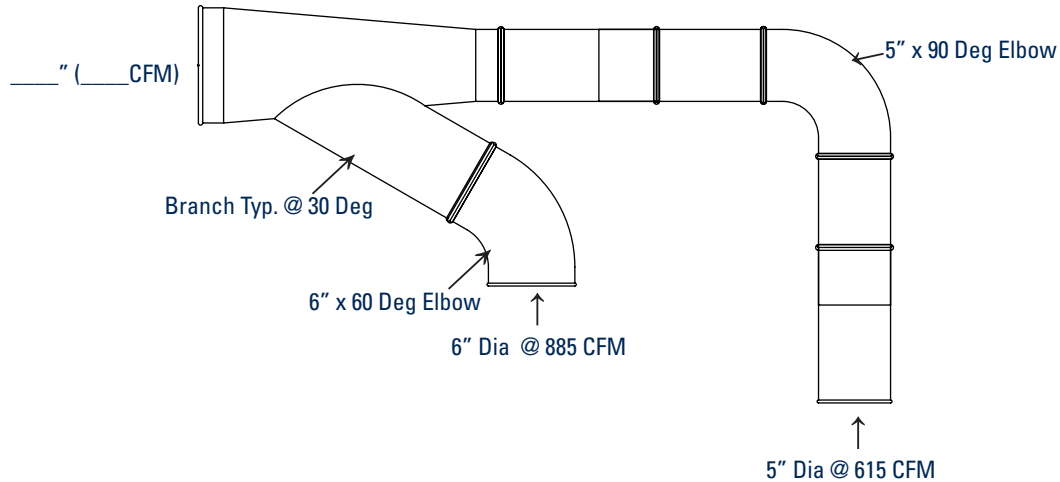

EXAMPLE: Always work from your machines back toward the filter. Suppose that you have a 5" drop that rises and runs back to join with a 6" drop as sketched above. What size branch will you need?

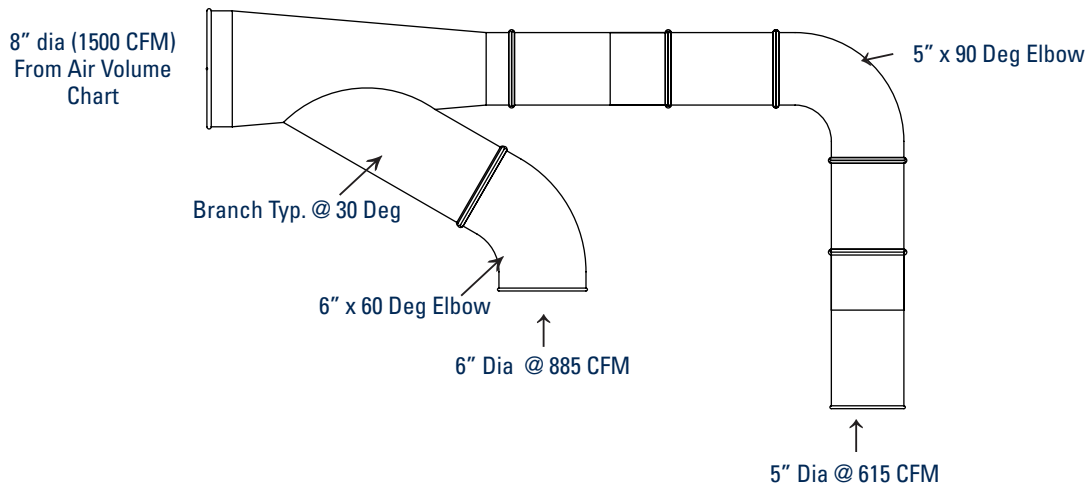

The 5" pipe carries 615 CFM at 4500 FPM, (See Chart). The 6" pipe will need 885 CFM at the same velocity (See Chart). Added together you have a total of (615 + 885) 1500 CFM coming together. Looking again at the chart under 4500 FPM, you find that 1500 CFM is not listed, but falls very close to the 1570 CFM listed for an 8" pipe. This indicates that the 5" joined to the 6" will require an 8" pipe to carry all of the material at the right velocity. The branch, therefore, will be 8" on the downstream end reducing down to a 5" with a 6" branching off of it. That is listed as a 8-6-5 branch.

INSTALLING AN ADJUSTABLE NIPPLE

INSTRUCTIONS FOR USING THE "EASY DUCT" ADJUSTABLE NIPPLE WITH RUBBER O-RING FOR DRY SYSTEM

Each Easy Duct pipe section is 5 ft. in length. To shorten to accommodate an existing span, an adjustable nipple is used.



Measure distance to be spanned.

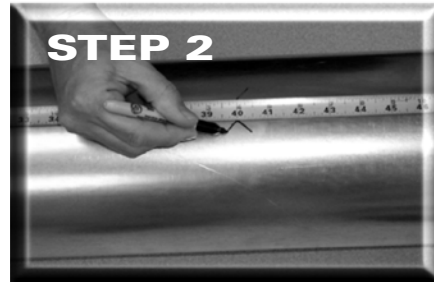

Mark distance to be spanned less 4".

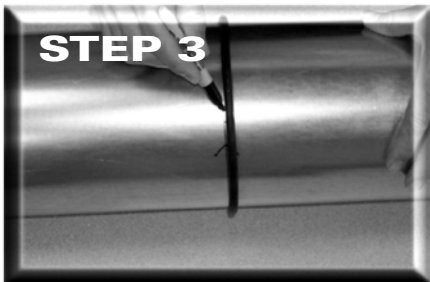

Use O-ring provided and mark for cut.



Drill access hole then cut with saw



Cut piece of pipe put O-ring on cut pipe, slide nipple over



Snap clamp over O-ring and one end of nipple.



Finished connection using the adjust nipple assembly.

NOTE: KEEP CUT PIPE IN THE DIRECTION AS THE AIR FLOW.

OIL, MIST OR WET APPLICATION FOR PIPE

INSTALLATION OF DUAL-GASKETING FOR OIL, MIST OR WET APPLICATIONS FOR EASY DUCT STANDARD ROLLED EDGE PIPE

Standard Easy Duct parts are well-suited for most dust, smoke and fume collection systems. However, on oil-mist or other “wet” systems, a dual gasket is recommended to eliminate leakage of materials condensing inside the pipe. Also industry or government regulations occasionally require dual-gasketing on certain dry or fume systems.



INSTALLING THE OIL MIST GASKET BETWEEN STANDARD ROLLED-EDGE SECTIONS OF PIPE.

1. Carefully place the gasket along the rolled edge of the part, being careful to avoid kinks or voids. Only one gasket is needed per joint.

2. Join the gasketed end of the pipe to a non-gasketed end of the next part in the ducting run using a standard Q-F clamp. The oil-mist gasket, in addition to the gasket inside the Q-F clamp, provides dual protection against leakage.



OIL, MIST OR WET APPLICATION INSTALLATION OF ADJUSTABLE NIPPLE



INSTALLING A SECOND O-RING IN A EASY DUCT ADJUSTABLE NIPPLE.

1. When a non-standard length of pipe is needed, use a standard Easy Duct Adjustable Nipple to span the gap.



2. Place the small-diameter soft o-ring between the standard o-ring and the rolled edge of the nipple. The soft o-ring should be seated evenly against the rolled edge.



3. Position the larger-diameter standard Easy Duct o-ring above the oil-mist ring. The order should be as follows:
a) rolled edge or nipple; against
b) soft, small-diameter o-ring; against
c) standard Easy Duct O-ring.



4. Clamp a standard EASY DUCT clamp around both o-rings and the rolled edge. Make sure that both o-rings fit completely under the clamp.

NOTE:
KEEP CUT PIPE IN THE DIRECTION AS THE AIR FLOW

AIR VOLUME CHART (CFM)

AIR VOLUME IN DUCTS IN CUBIC FEET PER MINUTE (CFM)												
DUCT Ø	VELOCITY IN FEET PER MINUTE (FPM)											
	2000	2500	3000	3500	4000	4500	5000	5500	6000	6500	7000	
3	100	125	150	170	195	220	245	270	295	320	345	
4	175	220	260	305	350	395	440	485	525	570	615	
5	275	340	410	475	545	615	680	750	820	885	955	
6	395	490	590	685	785	885	980	1080	1180	1275	1375	
7	535	670	800	935	1070	1205	1335	1470	1605	1735	1870	
8	700	875	1050	1220	1395	1570	1745	1920	2095	2270	2445	
9	885	1105	1325	1545	1765	1990	2210	2430	2650	2870	3090	
10	1090	1365	1635	1910	2180	2455	2725	3000	3270	3545	3820	
11	1320	1650	1980	2310	2640	2970	3300	3630	3960	4290	4620	
12	1570	1965	2355	2750	3140	3535	3925	4320	4710	5105	5500	
13	1850	2300	2770	3225	3685	4150	4610	5070	5530	5990	6450	
14	2140	2675	3205	3740	4275	4810	5345	5880	6415	6950	7485	
15	2450	3070	3680	4300	4900	5520	6130	6750	7360	7970	8590	
16	2790	3490	4190	4885	5585	6285	6980	7680	8380	9075	9775	
17	3150	3940	4730	5515	6300	7090	7880	8670	9450	10240	11030	
18	3535	4420	5300	6185	7070	7950	8835	9720	10600	11485	12370	
20	4365	5455	6545	7635	8725	9815	10910	12000	13090	14180	15270	
22	5280	6600	7920	9240	10560	11880	13200	14520	15840	17160	18480	
24	6285	7855	9425	10995	12656	14135	15710	17280	18850	20420	21995	
26	7370	9210	11055	12900	14740	16580	18420	20270	22110	23950	25800	
28	8550	10685	12820	14960	17100	19230	21310	23500	25650	27780	29920	
30	9800	12260	14700	17170	19625	22080	24530	26990	29440	31890	34350	
32	11160	13950	16750	19541	22330	25120	27910	30700	33490	36280	39070	
34	12600	15755	18905	22055	25210	28360	31510	34660	37810	40965	44115	
36	14130	17665	21195	24730	28260	31800	35325	38860	42390	45925	49455	
38	15745	19680	23615	27550	31490	35425	39360	43295	47230	51170	55100	
40	17445	21800	26170	30530	34890	39250	43610	47975	52330	56700	61055	

Industry-Leading Technology

- Advanced filtration technology for optimal performance
- Reduced energy consumption and cost of ownership
- Advanced design and testing capabilities

The Most Filters and Parts

- For every brand and style of collector
- Wide range of filtration media for any application
- 90,000 filters and parts in stock and ready to ship

Unparalleled Support

- Live technical specialists
- Comprehensive pre- and post-sale support
- 40 manufacturing plants and 14 distribution centers worldwide

Significantly improve the performance of your collector with genuine Donaldson Torit replacement filters and parts. **Call Donaldson Torit at 800-365-1331.**

Important Notice

Many factors beyond the control of Donaldson can affect the use and performance of Donaldson products in a particular application, including the conditions under which the product is used. Since these factors are uniquely within the user's knowledge and control, it is essential the user evaluate the products to determine whether the product is fit for the particular purpose and suitable for the user's application. All products, product specifications, availability and data are subject to change without notice, and may vary by region or country.



Donaldson.

Donaldson Company, Inc.
Minneapolis, MN
donaldson.com • shop.donaldson.com

North America
Email: donaldson@donaldson.com
Phone: (USA): +1-800-365-1331 • (MX): +1-800-343-36-39

Australasia
Email: marketing.australia@donaldson.com
Phone: +61-2-4350-2000
Toll Free: (AU) +1800-345-837 • (NZ) +0800-743-387

F118018 ENG (02/20) Easy-Duct Technical Manual ©2012-2020 Donaldson Company, Inc.
Donaldson, Torit, Easy-Duct and the color blue are marks of Donaldson Company, Inc. All other marks belong to their respective owners.

China
Email: info.cn@donaldson.com
Phone: +86-400-820-1038

Donaldson Europe B.V.B.A.
Email: IAF-europe@donaldson.com
Phone: +32-16-38-3811

India
Email: info.difs@donaldson.com
Phone: +91-124-4807-400 • +18001035018

Japan
Email: jp-ndl.lifsw@donaldson.com
Phone: +81-42-540-4112

Korea
Email: iaf-kr@donaldson.com
Phone: +82-2-517-3333

Latinoamerica
Email: IndustrialAir@donaldson.com
Phone: +52-449-300-2442

South Africa
Email: SAMarketing@donaldson.com
Phone: +27-11-997-6000

Southeast Asia
Email: IAFSEA@donaldson.com
Phone: +65-6311-7373