

FORMING THE FUTURE



THE ENTIRE WORLD OF FORGING

SCHULER 

Member of the ANDRITZ GROUP

FORMING THE FUTURE

PUT IT INTO MOTION.
FORGING WITH SCHULER.



Hydraulic press for forging ring blanks.

SCHULER FORGING.

As a leading supplier of cold, warm and hot forging systems, Schuler offers everything from a single source – from component development and process planning through die making and turnkey installation of efficient production systems. This deep experience of forging technology offers a decisive competitive advantage for productivity and quality.

This overview of extensive products and services provides comprehensive solutions for producing forged products with high part quality, maximum production availability and reliable process engineering. The Schuler team is ready to put it into motion.

Schuler welcomes a challenge.

01	FORGING PROCESSES	4
02	SCHULER ECOFORM	14
03	SYSTEMS FOR COLD FORGING	18
04	SYSTEMS FOR WARM FORGING	34
05	SYSTEMS FOR HOT FORGING	42
06	AUTOMATION SOLUTIONS FOR FORGING	84
07	ADDRESSES AND SCHULER SERVICE	90

SCHULER AROUND THE WORLD – FORMING THE FUTURE

Schuler is the technological and global market leader in forming equipment. We offer presses, hammers, automation, dies, process know-how and services for the entire metal forming industry. Our clients include car manufacturers and their suppliers, as well as companies in the forging, appliance, packaging, energy and electrical industries. We are the market leader in coin minting presses and supply systems solutions for the aerospace, railway and large pipe industries. Innovation is in our DNA: Schuler technology ensures maximum productivity, high levels of energy-efficiency and reliable mass manufacturing – also of lightweight parts. We showcase this cutting-edge technology at our TechCenters around the world. With around 5,400 employees, Schuler is represented in 40 countries and is a member of the Austrian ANDRITZ Group.

FORMING THE FUTURE

01



AT A GLANCE

FORGING PROCESSES

Schuler offers the entire process development from a single source, including consulting and training services.

To determine the best economic solution to produce quality parts, development of the forging process begins with part design, and must simultaneously consider material selection, process technology, production stages and die processes.

The part design and process plan form the basis for calculating the economic efficiency in the project planning phase. This means that the decision to use a forging process has been decided. Furthermore, the process plan provides information about the forging equipment required, the die system and the transfer system. These parameters must be considered simultaneously in order to achieve an optimum result.

PROCESSES	6
TEMPERATURE RANGES	8
PROCESS DEVELOPMENT	9
DIE CONSTRUCTION	10
COOLING DEVICE	11
PART FEED AND TRANSPORT SEQUENCE ANALYSIS	12
PRESS SYSTEM SELECTION	13

FORGING PROCESSES

PROCESSES

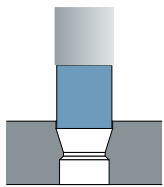

Reduction

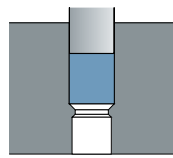
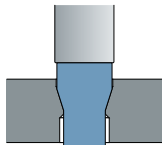

Full forward extrusion

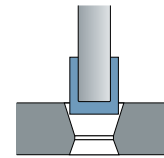
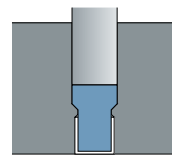

Ironing

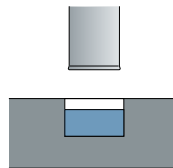
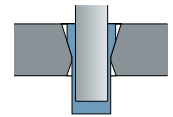

Backward extrusion

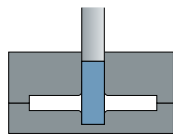
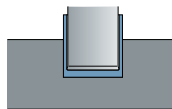

Lateral extrusion

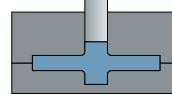

REDUCTION.

Reduction is a forging process in which the workpiece is forced through an opening in the die, fully or in part, involving a reduction in its cross section. Tapering of solid bodies results in a reduction in cross section, whereas hollow bodies, by contrast, are necked.

EXTRUSION.

Extrusion is a single or multi-station production process for creating both hollow and solid bodies. The process is distinguished according to the direction of material flow: forward, backwards or lateral. The workpiece is forced through an opening in the die with reduced cross section giving the workpiece its shape.

IRONING.

Ironing is carried out by pulling the workpiece through an ironing ring with the help of a punch. The wall thickness of the hollow body is reduced in this process.

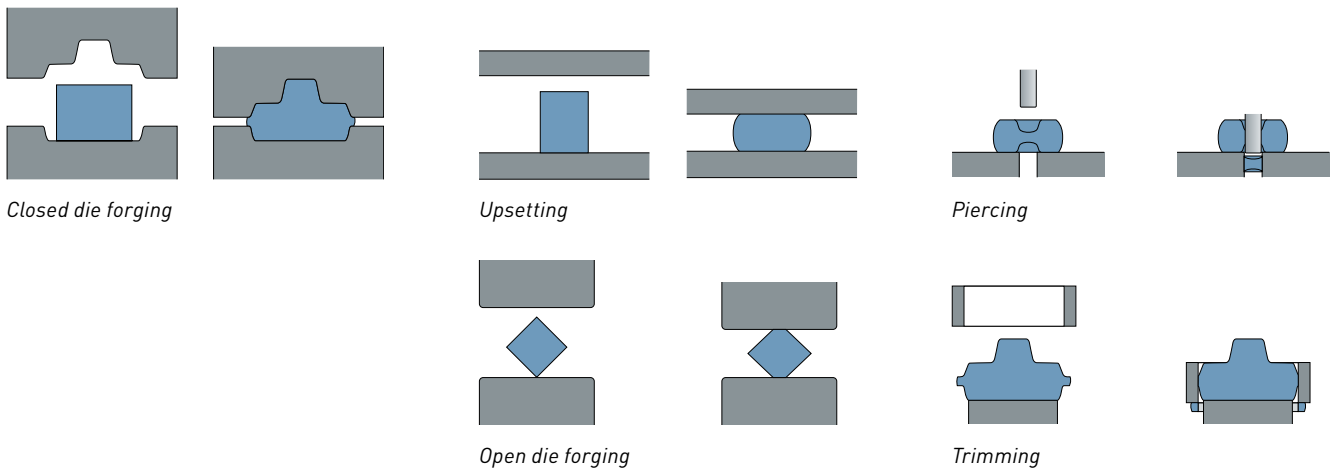

CLOSED DIE FORGING.

Closed die forging is a forging process in which dies move towards each other and cover the workpiece in whole or in part. The heated raw material, which is approximately the shape or size of the final forged part, is placed in the bottom die. The shape of the forging is incorporated in the top or bottom die as a negative image. Coming from above, the impact of the top die on the raw material forms it into the required forged form.

UPSETTING/OPEN DIE FORGING.

Upsetting and open die forging are also forging procedures. Upsetting is principally used for preliminary distribution of the material. In contrast to closed die forging, the workpiece is not completely enclosed during this forging process.

PIERCING/TRIMMING.

Piercing is used for incorporating holes and openings into a workpiece, which can have a wide range of shapes and sizes. Trimming involves removing surplus material (flash) from the workpiece.

FORGING PROCESSES

TEMPERATURE RANGES

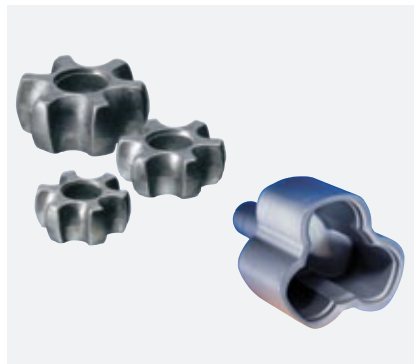

COLD FORGING
ROOM TEMPERATURE

- Extrusion
- Ironing
- Upsetting/setting
- Reduction
- Piercing

WARM FORGING
750 °C – 950 °C

- Extrusion
- Upsetting/setting
- Piercing

HOT FORGING
> 950 °C

- Closed die forging
- Forging ring blanks
- Upsetting
- Open die forging
- Extrusion
- Piercing/trimming

COMPREHENSIVE RANGE OF PRODUCTS AND SERVICES

Schuler system solutions. As a leading supplier of cold, warm and hot forging systems, Schuler offers you a decisive advantage over your competitors for productivity and quality. **Temperature ranges.** The different temperature ranges in forging are an important factor when selecting the process and for successful commercial production.

FORGING PROCESSES

PROCESS DEVELOPMENT

The object of developing the part design and process plan is to ensure that economical production can be achieved. It is necessary to consider the specific application and production situation.

For example, if the production volumes are low, then the objective is to achieve a process with only a few forging stations, and to plan for more complex secondary machining. An effective part design and process plan relies on know-how and practical experience.

During development of the process plan, the decision is made which forging process or which combinations of forging processes should be used: e.g. full forward extrusion, backward extrusion, reduction, upsetting, etc.

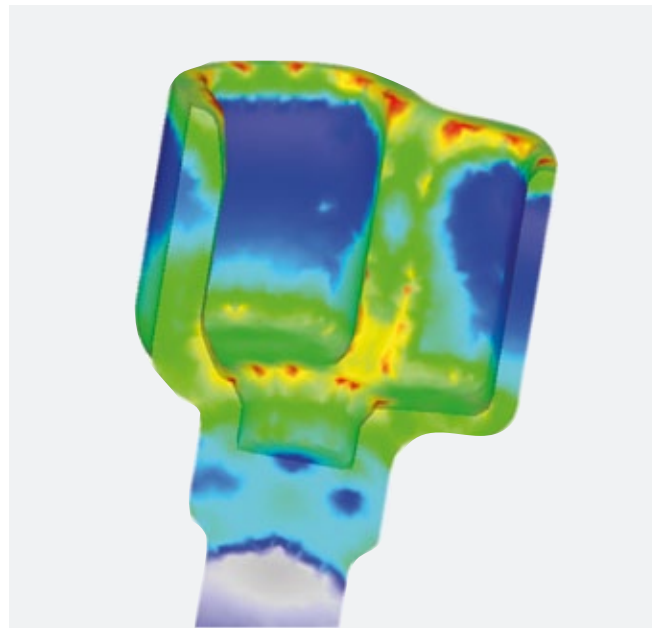

FEM simulation of a tripod joint housing.

PROCESS PLAN FOR TRIPOD HOUSING PRODUCTION

■ WARM FORGING

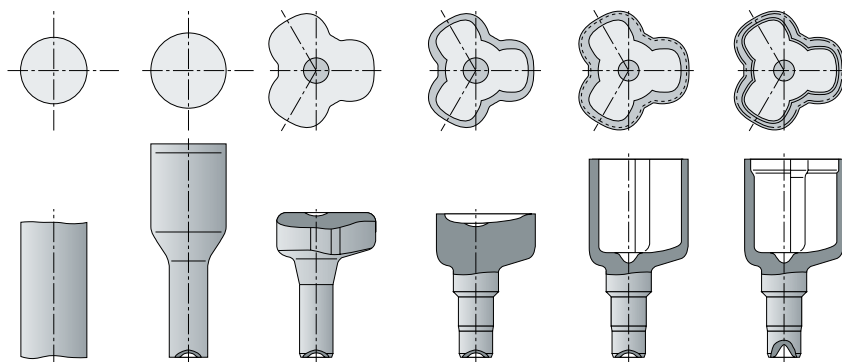

■ COLD FORGING

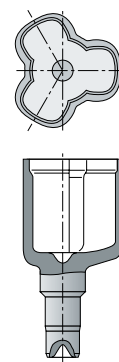

← Sequence development →

FORGING PROCESSES

DIE CONSTRUCTION



Die frame of an eccentric press.

- 1 Ejector pin
- 2 Thrust piece
- 3 Pneumatic spring
- 4 Inner punch
- 5 Outer punch
- 6 Spraying ring
- 7 Die
- 8 Reinforcement
- 9 Counterpunch
- 10 Thrust piece
- 11 Ejector pin

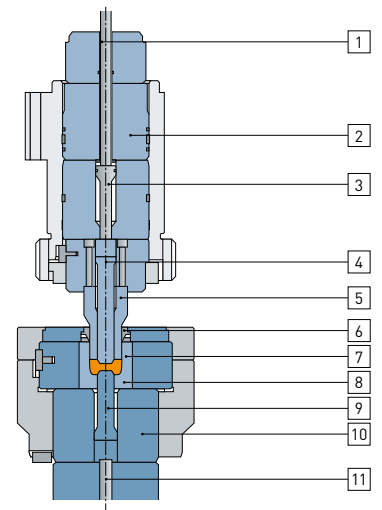

Die with inner punch and outer punch.

DIE CONSTRUCTION .

In practice, a critical part of die development is the configuration of the punches and dies. Not only the punches and dies are accommodated in the die holder, but also the other die elements. Modern forging dies are configured for various stations. This means additional forging, calibration, punching or trimming procedures are possible in the same operation (using four- or five-station die sets commonly found in operation today). Special dies, such as closing dies, can also be used. This significantly reduces production costs related to additional processing after the forging process.

FORGING PROCESSES

COOLING DEVICE

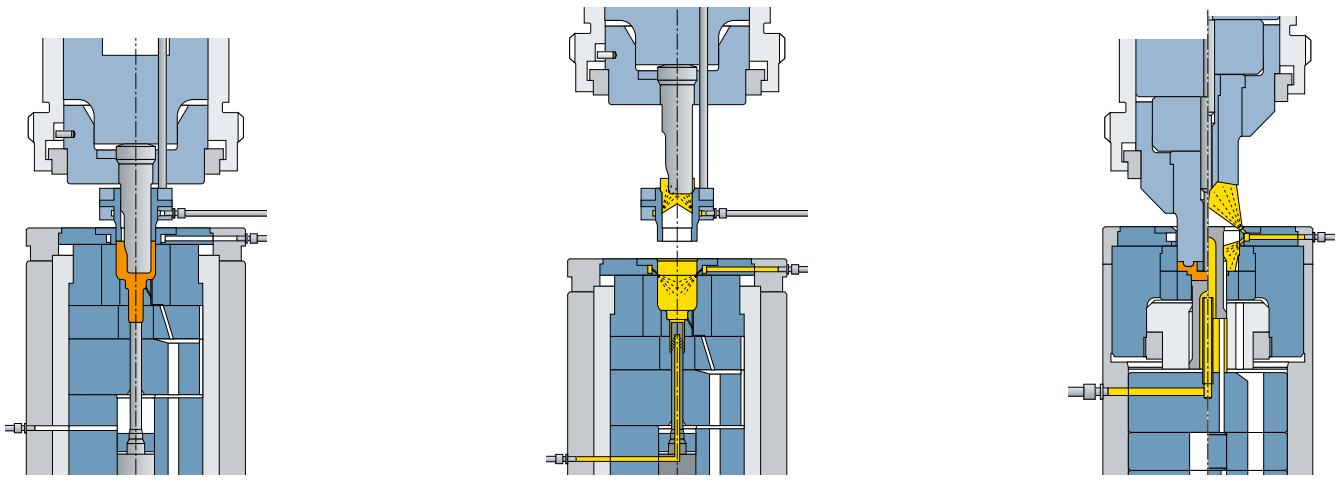

Die cooling and lubrication systems for warm and hot forging.

DIE COOLING AND LUBRICATION.

In warm and hot forging presses, effective cooling and lubrication systems are required. The shown solutions can provide optimum lubrication placement. In addition, the duration of the cooling and lubrication process can be optimized. This is an advantage compared to other systems such as linear manipulators, swivelling systems or systems that are mounted on transfer rails.

FORGING PROCESSES

PART FEED AND TRANSPORT SEQUENCE ANALYSIS

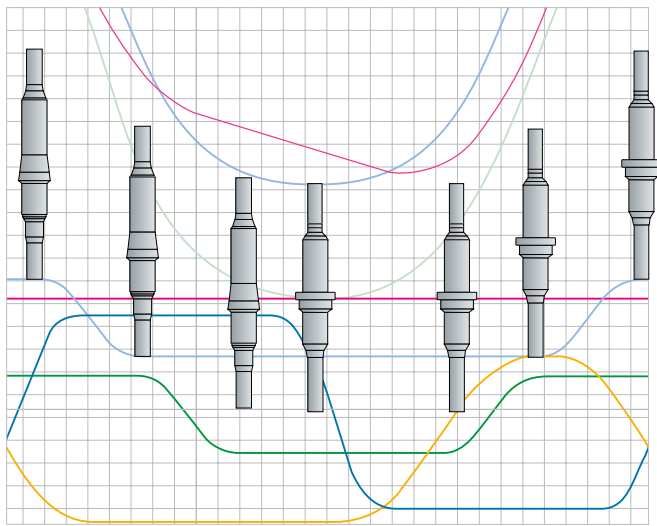

Analysis of part handling.

PART FEED AND TRANSPORT SEQUENCE ANALYSIS.

In the analysis of part handling, the path of every motion axis (slide, ejector and transfer) is coordinated. The data acquired in the handling analysis, such as travel distance and movement start/end points can then be transferred directly into the machine control.

THE OBJECTIVES OF THE PART FEED AND TRANSPORT SEQUENCE ANALYSIS

- Implementing a design with the maximum transport safety and max. output
- Collision-free transport of parts from station to station
- Quick and safe die commissioning
- Increased stroke rate/output

FORGING PROCESSES

PRESS SYSTEM SELECTION

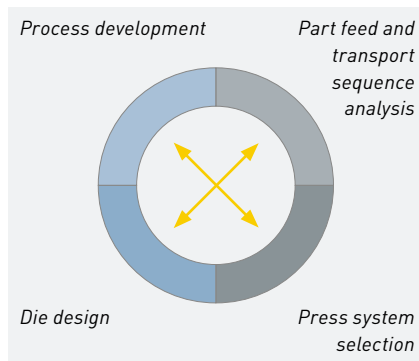

Integrated development of design, process and equipment.



Manual down stroking hammer for special forgings.



Turnkey solution for high-volume production of aluminum rims.

Schuler offers you individual solutions for all requirements in forging – irrespective of whether you need an individual press for manual operation or you are looking for a large turnkey solution. Schuler is also your expert partner for modernizations, conversions or performance increases.

Increasing product qualities, small batch sizes and just-in-time deliveries: Manufacturing forged components places demanding requirements on production systems and automation. Rely on Schuler's extensive expertise as a leading system supplier for cold, warm and hot forging. Whether small or large components, precision forgings or other technical challenges are involved, Schuler supports you in component development involving process development and diemaking through to the startup of your machine.

02



AT A GLANCE

SCHULER ECOFORM

SUSTAINABLE AND EFFICIENT FORGING

Schuler ECOFORM enables us to improve assemblies, system solutions, forming processes and procedures with energy efficiency in mind. ECOFORM offers the following: Analysis of energy used in the press plant, use of energy-efficient components, innovative system solutions, intelligent control solutions, and practical advice. Schuler ECOFORM is geared towards the future, perfectly combining innovation, sustainability, and cost-effectiveness.

SUSTAINABILITY IS DRIVING OUR INNOVATIONS 16

INTELLIGENT, WITHOUT THE NEED FOR OPERATOR INTERVENTION 17



SUSTAINABLE
FORMING SOLUTIONS

ENERGY-EFFICIENT AND COST-EFFECTIVE FORGING

SUSTAINABILITY IS DRIVING OUR INNOVATIONS

Energy costs – a decisive factor in the press plant.

Is it possible to minimize the resource consumption for presses and automation equipment while achieving long-term financial success? Sustainability and energy efficiency are major trends in our world – They are changing our society and revolutionizing the economy. Schuler offers real answers to these global challenges and thereby offers you the opportunity to optimally equip your systems and production facilities with the future in mind.

Forming the Future. Many of us have sustainability on our minds – as technological and innovative leaders in forming technology, it is simply part of our DNA. Armed with our expertise and knowledge of markets and processes, we provide the answers to pressing questions regarding the forming industry with intelligent, cross-sector system solutions which utilize various technologies.

Schuler is pressing onwards. With the development of technologies that allow our customers to produce their goods energy-efficiently, while conserving resources, as well as simultaneously increasing their productivity levels. The range is called: ECOFORM.

SCHULER ECOFORM OFFERS THE FOLLOWING:

USE OF ENERGY-EFFICIENT COMPONENTS

We utilize new components with maximum savings potential, which increase the degree of efficiency. Individual components and assemblies are replaced by energy-optimized components.

INNOVATIVE SYSTEM SOLUTIONS

Optimized provision of drive power in line with demands through implementing system-wide and process-independent solutions, such as intelligent energy recovery and start-stop and standby systems.

INTELLIGENT CONTROL SOLUTIONS

24/7 monitoring based on innovative measuring systems and live evaluation, as well as data and software solutions for energy-optimized processes.

TRIED AND TESTED

INTELLIGENT, WITHOUT THE NEED FOR OPERATOR INTERVENTION



Hydraulic forging press with EHF (Efficient Hydraulic Forming). Energy saving of 60%.

Savings of up to 60%. Efficient Hydraulic Forming is used by Schuler to considerably reduce the energy required by hydraulic presses. In particular, it comes into play for processes with long non-productive times. This takes place automatically for all processes, in all operating modes, and all power classes – without any operator intervention!



First linear hammer with ServoDirect technology.

20% savings. The new servo drive technology from Schuler enables a maximum degree of adaptability to the increasingly specialized fields of application and processes inherent to forging. Now that hard-on-hard blows are a thing of the past, fewer forging blows are required, meaning that the cycle time and therefore energy consumption is reduced. Perfectly complemented by the non-contact, zero-maintenance linear drive, which directly converts electrical energy into the mechanical movement of the ram hammer, energy savings of up to 20% can be achieved.

FORMING THE FUTURE

SCHULER 

03



AT A GLANCE

SYSTEMS FOR COLD FORGING

Cold forging allows components to be manufactured with very high dimensional accuracy combined with impressive output rates. By the very nature of the process, there is no scale formation or shrinkage, and the die wear is also very low. The material is not heated prior to forging in this process. The strain-hardening resulting during forging makes it possible to achieve elevated component strength levels while using low-cost raw materials.

Cold forging machines are suited to a wide range of components. This range includes components for engines, gearboxes and suspension systems that have small length/diameter ratios as well as long-shaft components such drive shafts, gearbox shafts and axles with large length/diameter ratios. Our customers from all over the world manufacture CO₂ cartridges, shock absorbers and hollow shafts on ironing presses.

HYDRAULIC COLD EXTRUSION PRESSES	20
HYDRAULIC IRONING PRESSES	24
KNUCKLE-JOINT PRESSES	27
KNUCKLE-JOINT PRESSES WITH SERVODIRECT TECHNOLOGY	30
FORMMASTER	31
FORMMASTER WITH SERVODIRECT TECHNOLOGY	33

COLD FORGING

HYDRAULIC COLD EXTRUSION PRESSES



Multi-station hydraulic cold extrusion press with 25,000 kN press force.

HIGH FLEXIBILITY ENSURES MAXIMUM ECONOMY.

The great flexibility of hydraulic systems is due to the ability of the user to program strokes, forces and speeds to fit the specific application, which makes cold forging an attractive solution. Single and multi-station hydraulic presses have an unlimited working capacity, offering advantages especially for long shaft-shaped parts.

Multi-station hydraulic presses require a very rigid press frame in conjunction with a tall slide in order to absorb the high off-center loads which result from the different force requirements of the individual stations. Schuler's patented RingValve prefill valves significantly shorten the cycle time of the hydraulic press. These valves provide fast filling of the hydraulic cylinders during rapid closing.

OVERVIEW OF COLD EXTRUSION PRESS MODELS

Model	MH 315	MH 500	MH 630	MH 800	MH 900	MH 1000
Press force [kN]	3,150	5,000	6,300	8,000	9,000	10,000
Max. slide stroke [mm]	250 - 750	250 - 750	500 - 1,000	500 - 1,000	500 - 1,000	500 - 1,250
Number of stations	1 - 3	1 - 3	1 - 4	1 - 4	1 - 4	1 - 5

Model	MH 1250	MH 1600	MH 2000	MH 2500	MH 3150	MH 4000
Press force [kN]	12,500	16,000	20,000	25,000	31,500	40,000
Max. slide stroke [mm]	700 - 1,250	700 - 1,250	900 - 1,250	900 - 1,250	900 - 1,250	900 - 1,250
Number of stations	1 - 5	1 - 5	1 - 5	1 - 6	1 - 6	1 - 6

Subject to technical modifications. Different tonnages are available upon request.

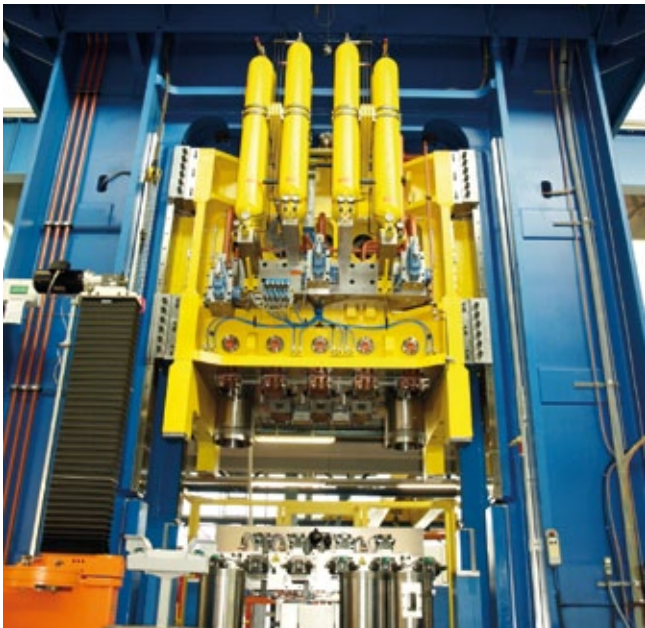

Multi-station hydraulic cold extrusion press with 16,000 kN press force.

The pressure in the cylinder can be released quickly so that the slide will start the return stroke without delay. Unlike traditional prefill valves, RingValve prefill valves can be opened under maximum pressure at bottom dead center, which significantly shortens the press release portion of the cycle. Presses with three cylinders allow Dynamic Force Control (DFC) to be used. The oil flow is automatically supplied to one, two or all three cylinders depending on the force required.

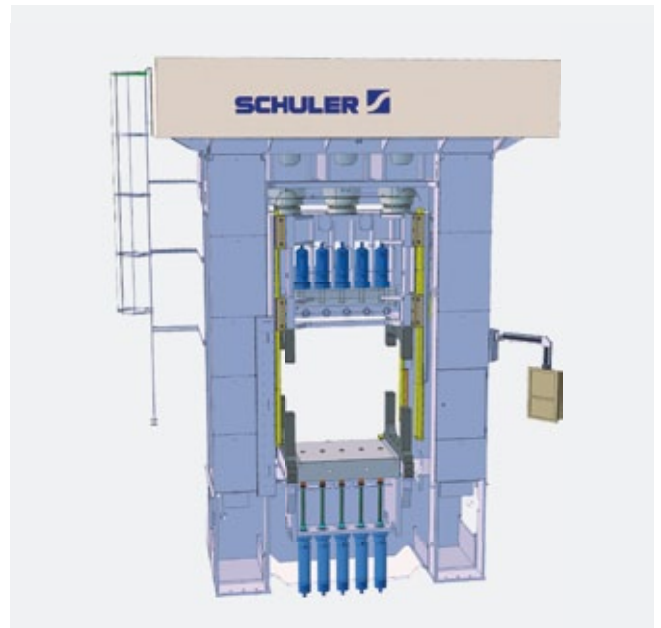

Layout of a multi-station hydraulic cold extrusion press.

The maximum working speed is three times faster than conventional presses with the same drives. As a result, further cycle time reductions can be achieved, particularly for cold extrusion presses, where the force requirement does not rise significantly until the end of the forging cycle. Various process sequences can easily be programmed and saved by the operator using an on-screen menu control system. In addition, integrated and highly flexible part handling ensures maximum productivity.

COLD FORGING

HYDRAULIC COLD EXTRUSION PRESSES



SYSTEMS FOR INDIVIDUAL REQUIREMENTS.

Because of the modular structure of Schuler's hydraulic presses, these cold extrusion presses can be adapted to the range of parts to be manufactured, as well as other customer requirements (e.g. available die concepts, spacing between stations).

Bed and slide surface, die space, stroke, number of stations and spacing between stations are flexible in the press design. Ejector concepts, as well as their forces and strokes, are defined according to the parts being manufactured. Stroke limitations, whether fixed or adjustable, and die change equipment are integrated as required.

The drive configuration ensures that required working speeds are reached, and therefore the desired output is achieved. The adaptable press geometry offers design flexibility for installation of automation with a tri-axis transfer (for high output) or robots (for high flexibility).

THE ADVANTAGES

- Tight parts tolerances because of rigid press frame and design
- High-precision workpieces due to precise slide guiding and motorized height adjustable hard stroke limitations in the bed and below the individual forging stations
- Increased output performance due to RingValve technology
- Part-specific optimization of the press cycle by Dynamic Force Control (DFC) for high output
- Low die wear due to low-speed contact (programmable motion curve)
- Increased flexibility with more forging stations
- Individually programmable ejectors in the bed and slide

THE APPLICATIONS

Long-shaft components such as:

- Drive shafts
- Axle shafts
- Transmission shafts
- Truck axles

COLD FORGING – HYDRAULIC COLD EXTRUSION PRESSES

CASE STUDY

CUSTOMER: AUTOMOTIVE SUPPLIER

THE REQUIREMENTS:

Fully automated press line for manufacturing shafts weighing up to 25 kg. Extremely high flexibility needed – the customer wishes to extend product range to non-automotive parts, such as large specialized screws.

THE SOLUTION:

Schuler supplied one hydraulic five-station transfer press with Dynamic Force Control.

- Press capacity: 25,000 kN
- Slide stroke: 1,000 mm
- Production rate: 12 parts/min
- Part loading and separation
- Tri-axis Compact Mono Beam Transfer using hydraulic active grippers and turnover grippers
- Five die sets
- Die change equipment



Tri-Axis Compact Mono Beam Transfer.

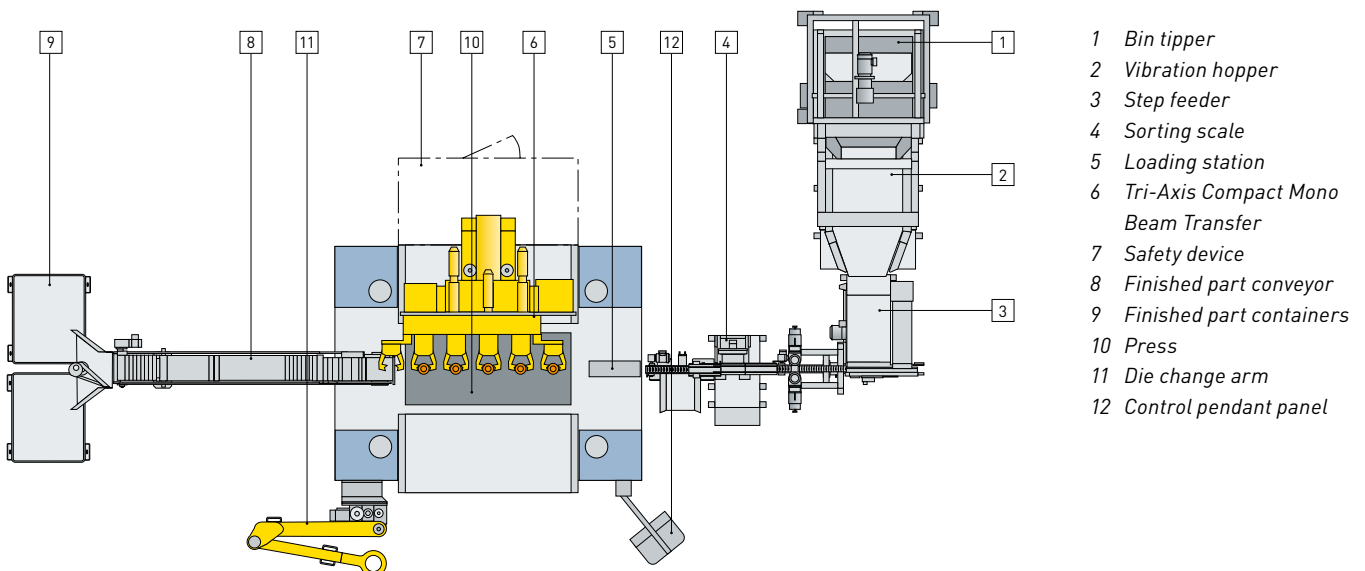

COLD FORGING

HYDRAULIC IRONING PRESSES



Manipulators transferring the blank from the parts conveyor into the die.



ECONOMICAL FORGING WITH COMBINED DRAWING AND IRONING IN ONE STROKE.

Hydraulic presses can form over almost unlimited stroke lengths under force, and therefore are well suited to wall ironing. In addition to traditional vertical forging systems, Schuler also offers horizontal presses. With ingenious integration of two die chambers in this design, the return stroke of the slide can also be used for forging, thereby increasing productivity.

THE ADVANTAGES

- High component quality in terms of accurate dimensions and shape, as well as surface quality
- Economical production with combined deep-drawing and ironing operations in one forging procedure
- No limits on component length due to unlimited working strokes of hydraulic press systems
- High output performance, particularly with horizontal press systems using two die chambers

THE APPLICATIONS

- Long, thin walled parts such as:
- CO₂ cartridges
 - Shock absorbers
 - Hollow shafts



Blanks and cups are processed on the same machine without any return stroke.

WHETHER SHORT OR LONG – NET SHAPE IS THE GOAL.

As a rule, one ironing operation is sufficient for calibrating precise components. Long, thin walled parts are generated in one stroke by relatively large reductions in the wall thickness on presses with long stroke length and several ironing rings arranged consecutively. The blanks are pulled through the die with the punch. In one cycle, the wall thickness is reduced precisely to the required dimension, the ultimate shape is created and the surface is smoothed.

OVERVIEW OF VERTICAL HYDRAULIC IRONING PRESS MODELS

Model	MH 315	MH 400	MH 500	MH 630	MH 800	MH 1000	MH 1250	MH 1600
Press force [kN]	3,150	4,000	5,000	6,300	8,000	10,000	12,500	16,000
Number of die chambers	1	1	1	1	1	1	1	1

Subject to technical modifications. Different tonnages are available upon request.

OVERVIEW OF HYDRAULIC IRONING PRESS MODELS IN HORIZONTAL DESIGN

Model	MHS 63/63	MHS 80/80	MHS 100/100	MHS 125/125	MHS 160/160	MHS 200/200	MHS 250/250	MHS 315/315
Press force [kN]	2 × 630	2 × 800	2 × 1,000	2 × 1,250	2 × 1,600	2 × 2,000	2 × 2,500	2 × 3,150
Number of die chambers	2	2	2	2	2	2	2	2

Model	MHS 400/400	MHS 500/500	MHS 630/630	MHS 800/800	MHS 1000/1000	MHS 1250/1250	MHS 1600/1600
Press force [kN]	2 × 4,000	2 × 5,000	2 × 6,300	2 × 8,000	2 × 10,000	2 × 12,500	2 × 16,000
Number of die chambers	2	2	2	2	2	2	2

Subject to technical modifications. Different tonnages are available upon request.

COLD FORGING

HYDRAULIC IRONING PRESSES



Line for manufacturing CNG gas cylinder tanks from blanks.



Die space.



COMPRESSED NATURAL GAS.

Today, more and more vehicles are driven with alternative fuels. The travel distance of gas-fueled vehicles depends significantly on the vehicle weight and the fill volume of the fuel tank. To deal adequately with both of these factors, it is necessary for the compressed natural gas (CNG) containers to withstand considerable internal pressure and also be

lightweight in design. Beginning with the blank, CNG containers are manufactured on Schuler machines in several drawing/ironing operations. A blank holder is integrated depending on the forging station.

CNG CONTAINERS FROM BLANKS.

Manufacturing CNG gas cylinder tanks from blanks offers many advantages. Blanks are easier and less expensive

to manufacture than seamless precision tubes. In addition, they have thinner bottoms compared to containers forged from a solid block. High surface quality is guaranteed by the integrated ironing process. Fully automated production processes and fast changeovers maximize productivity for the system.

THE ADVANTAGES

- Lower material cost of blanks as compared to precision tubes
- Lower weight than traditionally forged containers
- Larger container diameters are possible compared to traditional forging
- High surface quality

THE APPLICATIONS

- CNG gas cylinder tanks

COLD FORGING

KNUCKLE-JOINT PRESSES



Knuckle-joint press MMK2-1000.



Knuckle joint press with 6,300 kN press force.

EFFICIENCY, STEP BY STEP.

Knuckle-joint presses are suitable not only for high-volume production of small components but also for producing a variety of shafts, due to the large range of

slide strokes. The latest control systems make it possible to integrate the presses easily into fully automated production systems.

OVERVIEW OF KNUCKLE-JOINT PRESS MODELS

Model	MML 315	MML 400	MML 630	MML 800	MML 1000	MML 1200	MML 1600	MML 2000	MML 2500
Press force [kN]	3,150	4,000	6,300	8,000	10,000	12,000	16,000	20,000	25,000
Ram stroke [mm]	250 500	250 500	315 500	315 500	400 630	400 630	630 800	630 800	630 800
Stroke rate [strokes/min]	30 – 60 22 – 45	30 – 60 22 – 45	25 – 50 25 – 50	25 – 55 22 – 45	25 – 50 18 – 38	25 – 50 18 – 38	18 – 40 16 – 36	18 – 40 16 – 36	18 – 36 16 – 32
Bed surface [lr × fb mm]	1,000 × 600	1,000 × 600	1,250 × 710	1,250 × 710	1,500 × 1,000	1,500 × 1,000	1,800 × 1,000	1,800 × 1,000	2,200 × 1,000

Subject to technical modifications.

COLD FORGING

KNUCKLE-JOINT PRESSES



The variety of features and available functions such as bed and slide ejectors, blank feeding, transfer and die changes means that the systems can be used for specific applications or flexibly optimized for a wide range

of applications. The various designs that can be selected for kinematic motion of the slide enable these presses to be configured for warm forging as well.

THE ADVANTAGES

- High output rate
- Reduced forging speed
- Longer die life
- Wide range of applications

THE APPLICATIONS

- Parts for:
- Engines/transmissions
 - Drive components
 - Suspension components
 - Fasteners
 - Roller bearing elements

COLD FORGING – KNUCKLE-JOINT PRESSES

CASE STUDY

CUSTOMER: AUTOMOTIVE SUPPLIER



Knuckle joint press with automatic feed from the right, NC transfer system and finished part output.



THE REQUIREMENTS:

Supply a turnkey solution for economical series production of steering system components in the automotive industry.

THE SOLUTION:

Schuler supplied a knuckle-joint press:

- Press force: 8,000 kN
- Ram stroke: 450 mm
- Production rate: 50 parts/min
- 3-axis servo transfer system
- Automatic feed system with bin tipper
- Die lubrication system
- Die change equipment

COLD FORGING

KNUCKLE-JOINT PRESSES WITH SERVODIRECT TECHNOLOGY



Press with ServoDirect Technology.

SERVODIRECT TECHNOLOGY.

Combining the knuckle-joint drive with a servo motor makes it possible to improve upon the advantages of the knuckle-joint drive concept. This results in highly flexible production systems with increased output rates.

THE ADVANTAGES

- Increased output rates
 - Individually programmable ram speeds and motion sequences
 - Ability to optimize the forging process
 - High component quality and long die life
 - Ability to adapt slide movement to the transport sequence
 - Sensitive tryout operation possible
 - Optimized energy consumption
-

COLD FORGING

FORMMASTER



FormMaster with decoiler and straightening machine.



FormMaster with ServoDirect Technology in assembly.



Transfer system and die installation space for 6 forming stations.

Nowadays, shaped parts and fasteners are manufactured almost exclusively by forging processes. These processes combine high productivity with dimensional accuracy, for optimum grain flow and surface finish. At the same time, requirements for increased product quality, small batch sizes, complex parts geometries and just-in-time delivery conditions present production and automation systems with significant challenges.

OVERVIEW OF FORMMASTER MODELS

Model	FM 100	FM 130	FM 200	FM 250	FM 350	FM 500	FM 630
Press force [kN]	1,000	1,300	2,000	2,500	3,500	5,000	6,300
Forming stations	5/6	5/6	5/6	5/6	5/6	5/6	5/6
Wire cut-off at 600 N/mm ² [Ø mm]	14	15	21	23	25	30	36
Die diameter die side [Ø mm]	90	90	95	110	130	150	175
Die diameter punch side [Ø mm]	75	75	85	90	110	130	145
Cut-off length max. [mm]	125	140	160	180	195	260	290
Weight [t]	25	29	42	48	55	92	125
Production rate [ppm]	180	160	140	120	100	90	80

Subject to technical modifications. Different tonnages are available upon request.

COLD FORGING

FORMMASTER



With FormMaster multi-station presses, Schuler offers presses that meet these requirements. Designed in dialog with operators, production and maintenance specialists, tool-makers and designers, the FormMaster offers high productivity and maximum availability.

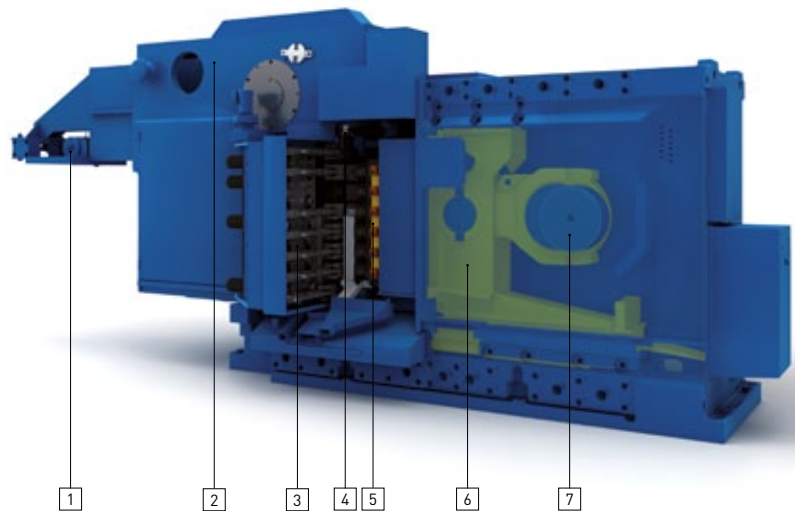

- 1 *Linear wire feed*
- 2 *Press frame*
- 3 *Transfer*
- 4 *Shearing level*

- 5 *Die and punch receptacles*
- 6 *Slide*
- 7 *Eccentric drive*

THE ADVANTAGES

- Optimum ergonomic access to die space
- High level of user friendliness
- Very good visibility of the die space
- Reliable servo transfer with transport parameters adjustable from the control panel

- Ease of maintenance
- Part transport monitoring
- Machine requires 30% less floor space
- Integrated die cooling/lubrication system

THE APPLICATIONS

Various parts from the fitting, joining, automotive industry, tools and hardware

COLD FORGING

FORMMASTER WITH SERVODIRECT TECHNOLOGY



FormMaster with pneumatically supported die change system.

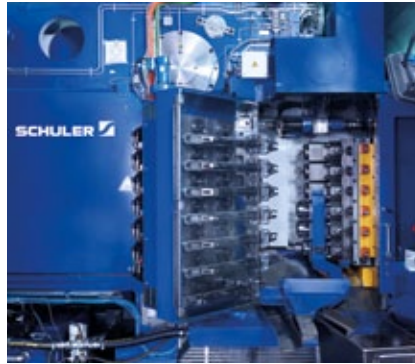

Transfer system and tools on slide side.



Servo motors of the FormMaster press.

OPTIMUM PRODUCTION CONDITIONS.

The servo drive enables the slide movement of the FormMaster horizontal cold header programmed for the specific parts. Even with a wide range of parts, it's possible to optimize the kinematics to the requirements of the forging process. Achieving optimum conditions for part transport with long parts, setting an optimum forging speed for part quality or to reduce die wear and producing critical extruded parts can all be done with high stroke rates and throughput.

THE ADVANTAGES

- High efficiency with optimized process
- Great flexibility due to adaptable slide movements
- Optimum ergonomic working position
- Very good visibility of the die space
- Reliable NC transfer with adjustable transport parameters
- Adapted forging speed for critical forgings
- Optimum clearance for long forgings
- Servo wire feed for high flexibility and accuracy

FORMING THE FUTURE

04

SCHULER 



AT A GLANCE

SYSTEMS FOR WARM FORGING

Systems for warm forging offer advantages to produce components with large dimensional changes and high precision. Prior to the first forging station, the components are heated to a temperature between 700°C and 950°C, depending on the application. The flow stresses are much lower than in the case of cold forging. Also, there is less distortion and scale formation than in hot forging.

Mechanical presses with eccentric or knuckle-joint drives are used in this temperature range. A great advantage to this process is that the die is almost entirely closed, and no flash is formed. The tight tolerances and lack of surface decarburization allow net-shape geometries or very small machining allowances to be achieved, thereby reducing the amount of material that needs to be used. The lower temperature compared to hot forging also requires less energy.

ECCENTRIC PRESSES 36

ECCENTRIC PRESSES WITH SERVODIRECT TECHNOLOGY 40

KNUCKLE-JOINT PRESSES
Information about knuckle-joint presses can be found starting on page 27

KNUCKLE-JOINT PRESSES WITH SERVODIRECT TECHNOLOGY
Information about knuckle-joint presses with ServoDirect Technology can be found starting on page 30

WARM FORGING

ECCENTRIC PRESSES



Eccentric press MME 1200.

SHORT CONTACT TIMES.

Eccentric presses are well suited for warm forging due to the sinusoidal motion sequence, as there is a short contact time and sufficient non-contact time available for die cooling.

This series of presses can be configured with 1 or 2-point slide attachment, and offers a wide range of rated press forces, with the ability to achieve long stroke lengths of 1,000 mm or even more. The generously sized die space permits the use of heavily reinforced dies. The flexible controls can incorporate a wide range of peripheral devices in order to make a fully automated production line.

THE ADVANTAGES

- Long stroke length
- High output rates
- Minimum contact times
- Extended non-contact times for die cooling
- Long die life
- Large die space
- Tight component tolerances and high component quality
- Optional servo drive

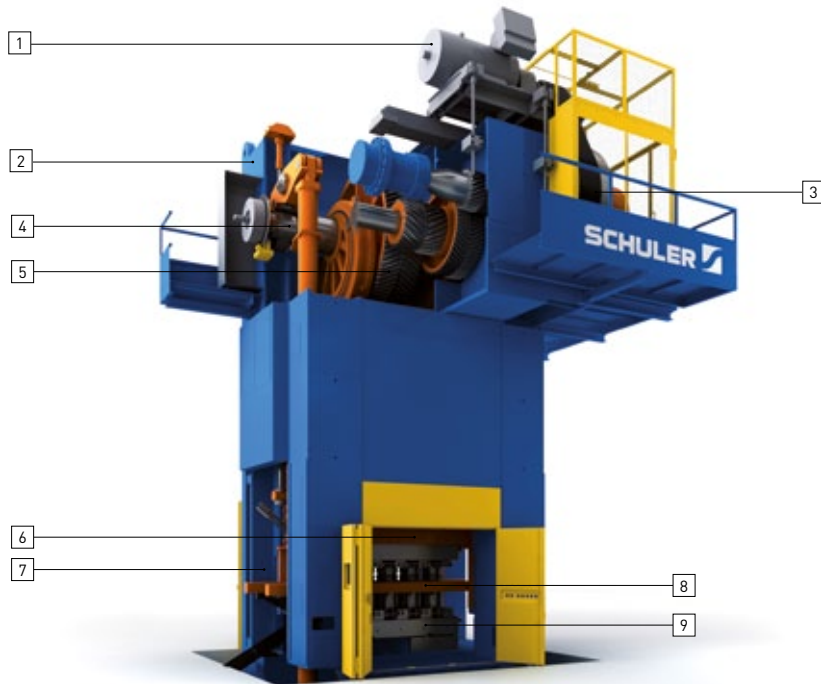

NC-transfer and die space area.

- | | |
|-----------------------------------|------------|
| 1 Main drive | 6 Slide |
| 2 Crown | 7 Upright |
| 3 Flywheel and clutch/brake | 8 Transfer |
| 4 Bed ejector with cam adjustment | 9 Die set |
| 5 Eccentric gears | |

OVERVIEW OF ECCENTRIC PRESS MODELS

Model	MME 315	MME 400	MME 630	MME 800	MME 1000	MME 1200	MME 1600	MME 2000
Press force [kN]	3,150	4,000	6,300	8,000	10,000	12,000	16,000	20,000
Ram stroke [mm]	250 500	250 500	315 500	315 500	400 630	400 630	630 800	630 800
Stroke rate [strokes/min]	30 – 60 22 – 45	30 – 60 22 – 45	25 – 50 25 – 50	25 – 55 22 – 45	25 – 50 18 – 38	25 – 50 18 – 38	18 – 40 16 – 36	18 – 40 16 – 36
Bed surface [lr × fb mm]	1,000 × 600	1,000 × 600	1,250 × 710	1,250 × 710	1,500 × 1,000	1,500 × 1,000	2,300 × 1,000 (1,750 × 1,000)	2,300 × 1,000 (1,750 × 1,000)

Subject to technical modifications.

WARM FORGING

ECCENTRIC PRESSES



The classic eccentric drive in its compact design is particularly suitable for use in warm forging. The drive kinematics, which can optionally be configured with a servo drive, combined with the high-performance bed and ram ejector systems, offer the best conditions for reliable workpiece handling and high output. It is also possible to integrate with multiple feeder and transfer devices. These presses can also be used successfully for cold forging and precision forging applications.

THE APPLICATIONS

Parts for:

- Engines/transmissions

- Drive components

- Suspension components

- Fasteners

- Roller bearing elements

WARM FORGING – ECCENTRIC PRESSES

CASE STUDY

CUSTOMER: AUTOMOTIVE SUPPLIER

THE REQUIREMENTS:

Deliver a fully automated line for warm forging production of driveline components.

THE SOLUTION:

Schuler delivered an eccentric press:

- Press force: 20,000 kN
- Ram stroke: 800 mm
- Output rate: 38 parts/min
- Induction heating with parts feed and temperature monitoring, with a system for gating-out parts
- 3-axis servo transfer system
- Cooling section
- Extensive die, cooling and lubrication accessories



Fully automated line for warm forging.

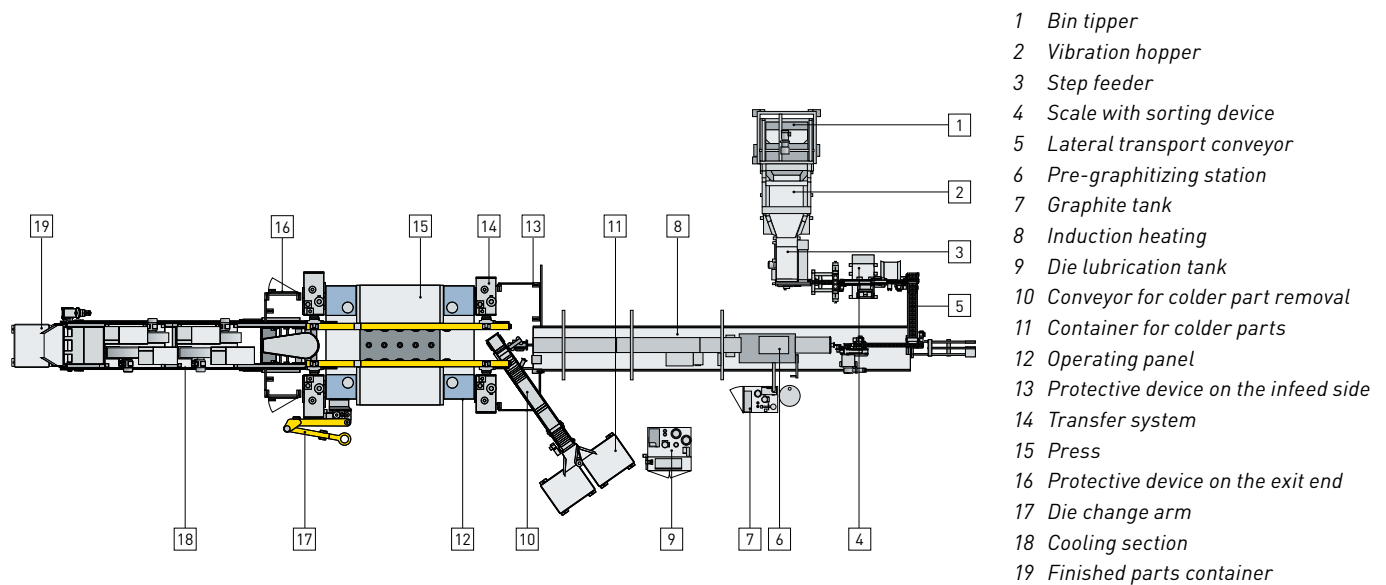
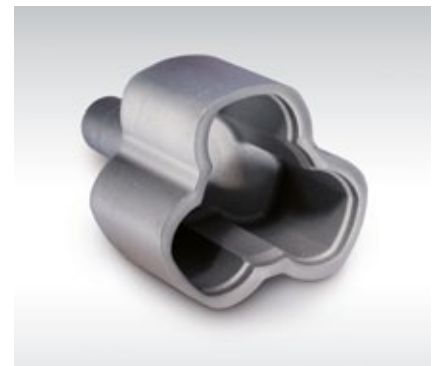

WARM FORGING

ECCENTRIC PRESSES WITH SERVODIRECT TECHNOLOGY

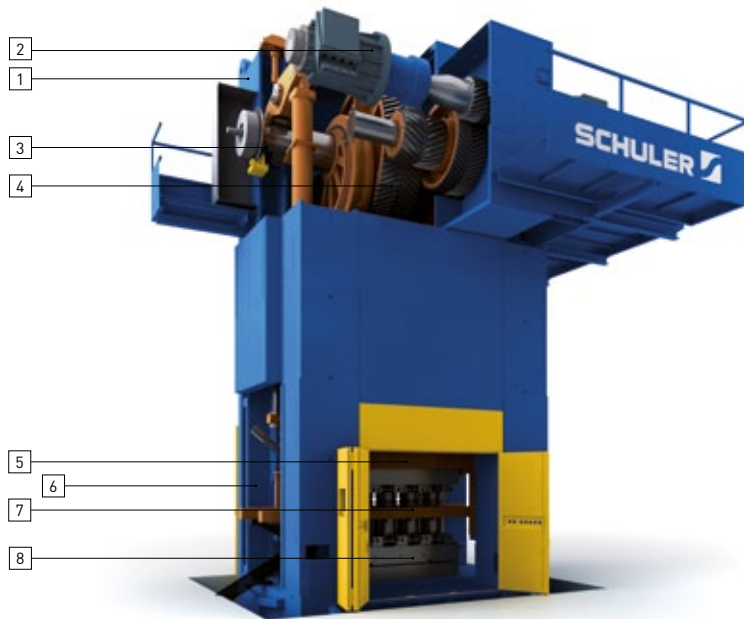

ServoDirect Technology replaces constant speed controlled 3-phase motor drives with flexible torque servomotors. The drive system does not have a flywheel, clutch nor brake. The main advantage of servo drive technology is that the slide kinematics are freely programmable, delivering higher productivity levels compared to conventional presses.

- | | |
|-----------------------------------|------------|
| 1 Crown | 5 Slide |
| 2 Servo motor | 6 Upright |
| 3 Bed ejector with cam adjustment | 7 Transfer |
| 4 Eccentric gears | 8 Die set |

THE ADVANTAGES

- High efficiency with throughput with optimized slide motion
- Best component quality even with complex parts
- Great flexibility due to adaptable slide movements
- Best energy efficiency compared to conventional presses
- Maximum process reliability
- Long stroke
- Optimized timing to handle long parts
- Start/stop operation now possible
- Setting up dies with reduced speed

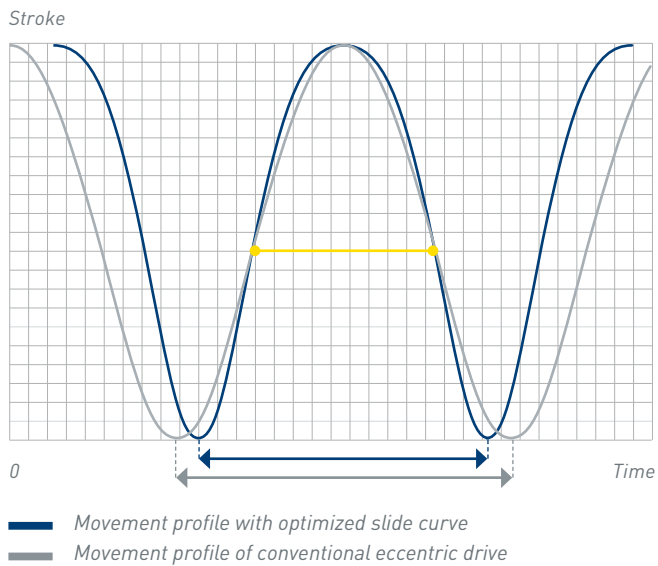

Increased output with the same transport timing due to the ability to program slide speed for a faster forging process in the die.

FLEXIBLE PRODUCTION SYSTEM.

This type of press is particularly suitable for components with an elongated shape, which have a high energy requirement due to their long forging travel. The combination of the eccentric drive and ServoDirect Technology permits increased productivity levels, because the slide kinematics can be optimally adapted to the automation.

05



AT A GLANCE

SYSTEMS FOR HOT FORGING

Schuler offers a wide range of products for hot forging that includes hammers, screw and crank presses, as well as hydraulic forging presses to support a variety of applications. In hot forging, the starting material is heated to a temperature at which recrystallization proceeds in parallel with forging.

The material does not undergo work hardening, and can be formed almost without restrictions. The choice of forging process enables the grain profile in the component to be adapted to the requirements. This leads to improved dynamic component properties.

DOWN STROKING HAMMERS	44
LINEAR HAMMERS WITH SERVO TECHNOLOGY	48
COUNTERBLOW HAMMERS	51
SCREW PRESSES WITH DIRECT DRIVE	55
CRANK PRESSES	61
CRANK PRESSES WITH SERVODIRECT TECHNOLOGY	63
PRESS CONTROL	66
SCHULER FORGE CONTROL SYSTEM (FCS)	
UPSETTER WITH SERVODIRECT TECHNOLOGY	68
HYDRAULIC OPEN DIE FORGING PRESSES	70
HYDRAULIC FORGING PRESSES	72
RING ROLLER	81
WHEEL ROLLER	82

HOT FORGING

DOWN STROKING HAMMERS



Down stroking hammer with oil hydraulic drive.



MAXIMUM EFFICIENCY EVEN IN SMALL-TO-MEDIUM BATCH SIZES.

Down stroking hammers are used for many kinds of applications, and are particularly suitable for small-to-medium sized parts. The sturdy, monoblock U-frame design, in conjunction with precise guides with a large surface area, provides high forging accuracy. The hydraulic down stroke drive permits high stroke rates combined with minimum contact times. The modern control system permits precise adjustment of the impact energy and stroke rate.

THE ADVANTAGES

- High stroke rate
- Minimum contact times
- Low operating costs
- Simple operation
- Guides with large surface area
- Universally applicable

THE APPLICATIONS

- Chassis components
- Flanges
- Connecting rods
- Turbine blades
- Hand tools



Drive head of a KGH 2.5.

ADDITIONAL EQUIPMENT

- Automation
- Anvil bed heating
- Anti-vibration installation
- Acoustic insulation
- Customer-specific custom solutions

- 1 Drive head
- 2 Piston rod
- 3 Slide
- 4 Upper die
- 5 U-frame
- 6 Lower die

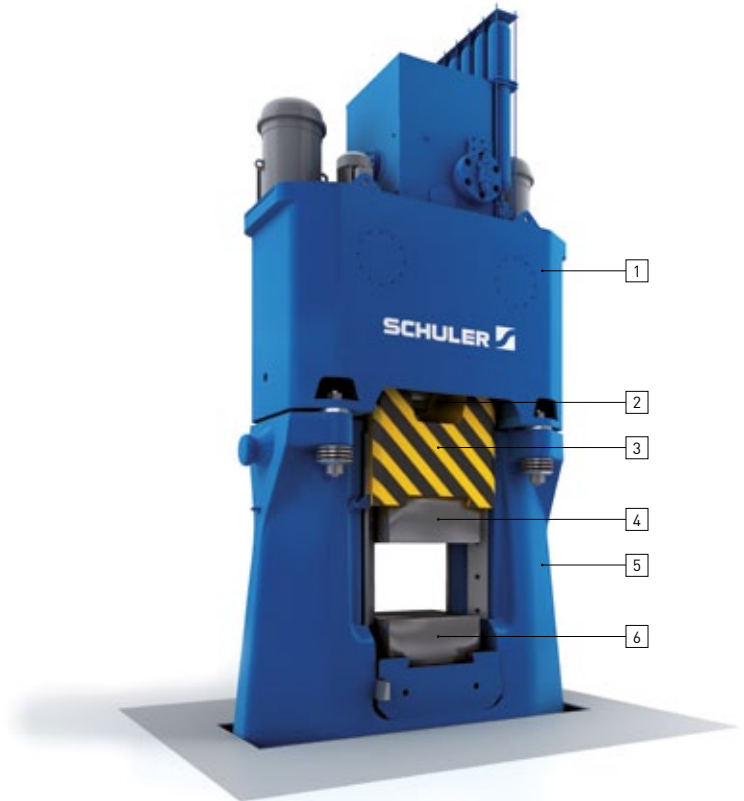

OVERVIEW OF DOWN STROKING HAMMER MODELS

Model	KGH 1.6	KGH 2	KGH 2.5	KGH 3.15	KGH 4	KGH 5	KGH 6.3	KGH 8	KGH 10	KGH 12.5	KGH 16
Working capacity [kJ]	16	20	25	31.5	40	50	63	80	100	125	160
Impact frequency max. [per min]	122	120	113	100	98	98	95	92	83	75	70
Slide stroke max. [mm]	635	665	685	755	790	775	805	835	885	1,160	1,190
Slide depth [mm]	470	510	550	595	640	695	750	830	890	1,020	1,050
Clearance between guides [mm]	520	570	608	664	717	766	831	890	960	1,060	1,150
Total die height max.* [mm]	320	345	360	420	455	435	465	495	540	720	750
Total weight [t]	24	30	36	46	60	75	96	121	143	195	235

*] without dovetails Subject to technical modifications.

HOT FORGING - DOWN STROKING HAMMERS

CASE STUDY

CUSTOMER: AN AUTOMOTIVE SUPPLIER

THE REQUIREMENTS:

Automatic forging cell for economically efficient production of engine and transmission parts, in addition to other components. The components have a single part weight of up to 4 kg and are intended to be forged as a multiple part.

THE SOLUTION:

Automatic hammer line with down stroking hammer KGH 4.0B. Part handling is performed by robots using special grippers. This makes it possible to use a safe forging process in the hammer.



Part handling and forging performed by two robots.



Automatic hammer line with down stroking hammer KGH 4.0B.

FULLY AUTOMATED FORGING CELL

- | | |
|------------------------------|------------------------------|
| 1 Furnace | 4 Robot |
| 2 Part feeding conveyor belt | 5 Robot |
| 3 Down stroking hammer KGH 4 | 6 'Pass' parts conveyor belt |

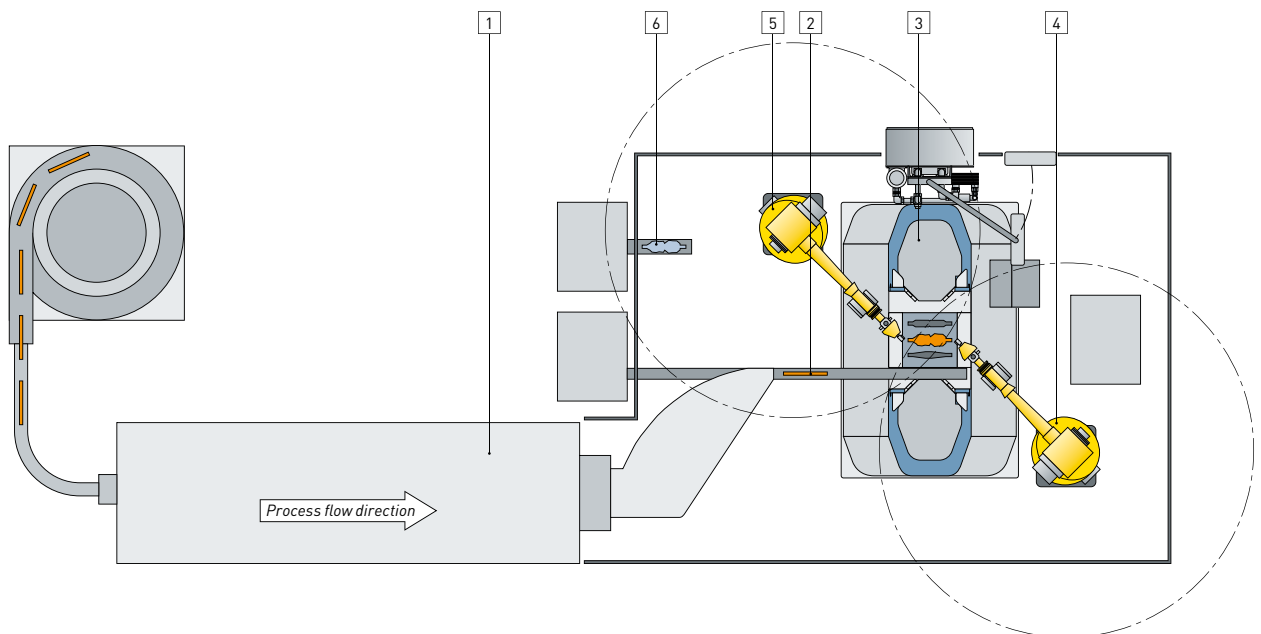

HOT FORGING

LINEAR HAMMERS WITH SERVO DIRECT TECHNOLOGY



Linear hammer with ServoDirect Technology.



MAXIMUM IMPACT ACCURACY WITH LINEAR DRIVE.

The newly developed and patented drive system for down stroking hammers impresses with maximum impact accuracy, for highly sensitive forging processes or demanding customer requirements.

The non-contact linear drive is almost wear-free, extremely dynamic and offers the possibility of flexible stroke control. This means the machine can be adapted to the requirements of the forging process with the maximum degree of effectiveness.

THE ADVANTAGES

- No operating medium
- Highest precision
- Process adaptability
- Perfect for automation
- Wide Information

THE APPLICATIONS

- Chassis components
- Flanges
- Connecting rods
- Turbine blades
- Hand tools

ADDITIONAL EQUIPMENT

- Automation
- Anvil bed heating
- Anti-vibration installation
- Acoustic insulation
- Customer-specific custom solutions

HOT FORGING

LINEAR HAMMERS WITH SERVO DIRECT TECHNOLOGY



- 1 Drive head with linear drive
- 2 Slide
- 3 Upper die
- 4 U-frame
- 5 Lower die

OVERVIEW OF LINEAR HAMMER WITH SERVO DIRECT TECHNOLOGY MODELS

Model	KGE 1.6	KGE 2	KGE 2.5	KGE 3.15	KGE 4	KGE 5	KGE 6.3
Working capacity [kJ]	16	20	25	31.5	40	50	63
Impact frequency max. [per min]	135	130	125	110	108	106	104
Slide stroke max. [mm]	635	665	685	755	790	775	805
Slide depth [mm]	470	510	550	595	640	695	750
Clearance between guides [mm]	520	570	608	664	717	766	831
Total die height max.* [mm]	320	345	360	420	455	435	465
Total weight [t]	22	28	34	44	57	72	96

*) without dovetails Subject to technical modifications.



Drive head of a linear hammer.

MAINTENANCE-FREE DRIVE.

As the forging hammer works with a non-contact, electrically driven linear motor, the standard hydraulic drive head is no longer required. As such, the dynamically highly loaded parts are reduced to a minimum, with the linear hammer being particularly low-maintenance.



Optimum automation.

FLEXIBLE PROCESSES.

Process extension. The forging hammers can be quickly and easily adapted to various tasks. This is how preform operations (descaling, bending) as well as setting blows and press operations (trimming, piercing) are implemented.

Automated processes. Thanks to the fully electrical drive concept, the linear hammer can be integrated into automated systems in the simplest of ways. The exact path control and recording of the tup in automatic mode allows for process reliability and the cycle time to be increased.



Operating the press via the touchscreen is intuitive and user-friendly.

PRECISE AND INFORMATIVE.

Maximum precision. Forge hammers are renowned for their high degree of precision and repeatability. This is because of a stroke precision <math><0.5\%</math>, exact positioning with a deviation of less than $\pm 0.05\text{ mm}$ and continual thickness measurements.

Well informed. The ServoDirect drive of the linear hammer enables various pieces of process data to be continually recorded, such as distance and speed curves. Such data can be exported for optimization and processing in PDA systems.

HOT FORGING – LINEAR HAMMER WITH SERVODIRECT TECHNOLOGY

CASE STUDY

CUSTOMER: SUPPLIER FOR SAFETY PARTS



Forging hammer with ServoDirect technology.



Precision forging with the linear hammer.



Modern plant operating system with touchscreen.

THE REQUIREMENTS:

Precise, energy-efficient, and high flexibility are the three main requirements placed on a modern forging hammer. The new linear hammer with ServoDirect technology should be able to meet such demands.

THE SOLUTION:

Schuler developed a patented hammer drive, which is characterized by its extraordinary precision in terms of path control and impact energy dosage.

This enables precisely tailored forging without impact faces. The new drive concept also allows for combined forging operations (pre-upsetting, bending, pre-forging, final forging, trimming) to be performed under the hammer, as any conceivable motion sequences can be implemented with the drive - from hammering to pressing.

HOT FORGING

COUNTERBLOW HAMMERS

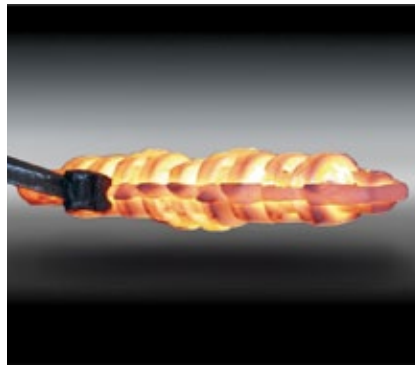

Pneumatic counterblow hammer with a rated capacity of 800 kJ.

FOR LARGE FORGED PARTS.

BÊCHÉ counterblow hammers with hydraulic tup coupling are predominantly used for manufacturing large and ultra-large forgings. The high impact energy and tonnage of the hammer dies, moving in opposite directions, permits precision forming of large forgings.

THE ADVANTAGES

- Extremely high impact energy and tonnage
- High reliability and availability
- High stability of the overall structure
- High precision with large forgings
- Hydraulic tup coupling
- Long stroke for accessibility
- Modern control system
- A vibration insulator is not required

THE APPLICATIONS

- Crankshafts
- Turbine blades
- Driveline and chassis components for cars and trucks
- Flanges and disks

ADDITIONAL EQUIPMENT

- Die change systems
- Tup heating systems
- Ejector systems
- Spraying systems
- Manipulators

HOT FORGING

COUNTERBLOW HAMMERS

HYDRAULIC COUNTERBLOW HAMMERS



Power pack of a hydraulic counterblow hammer.

Counterblow hammers with hydraulic drives are particularly well suited to the medium tonnage range. There is no need for an extensive compressed air system.

- 1 Drive head
- 2 Piston rod
- 3 Upper tup
- 4 Upper die
- 5 Upright
- 6 Tup support
- 7 Lower die

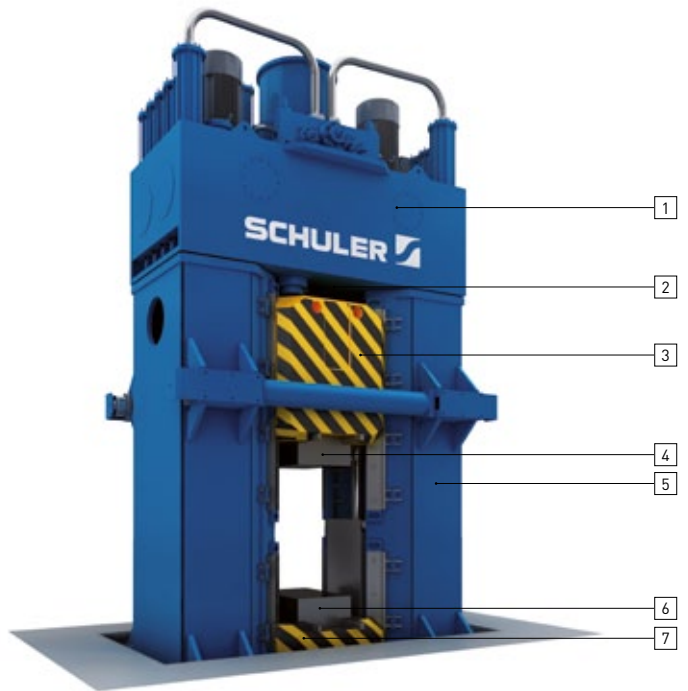

OVERVIEW OF HYDRAULIC COUNTERBLOW HAMMER MODELS

Model	HG 16	HG 20	HG 25	HG 31.5	HG 40
Working capacity [kJ]	160	200	250	315	400
Impact frequency max. [per min]	50	50	50	45	45
Slide stroke max. [mm]	745	840	840	910	960
Slide depth [mm]	1,450	1,600	1,750	1,800	2,150
Clearance between guides [mm]	1,100	1,200	1,300	1,350	1,500
Total die height max.* [mm]	630	710	710	800	900
Total weight [t]	133	161	203	255	322

*) without dovetails Subject to technical modifications.

HOT FORGING

COUNTERBLOW HAMMERS

PNEUMATIC COUNTERBLOW HAMMER

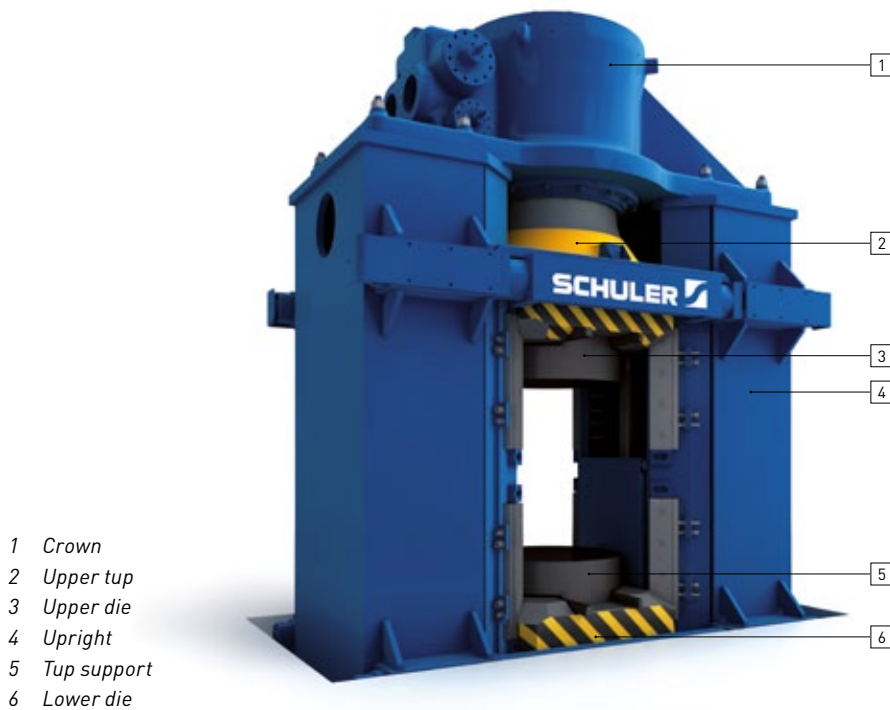

- 1 Crown
- 2 Upper tup
- 3 Upper die
- 4 Upright
- 5 Tup support
- 6 Lower die



Drive of a pneumatic counterblow hammer.

This series employs the proven pneumatic drive concept. It allows very large forging energy levels to be achieved. The sturdy design of the uprights, together with a solid guide system, ensures high precision during forging. The robust design ensures a high level of availability.

OVERVIEW OF PNEUMATIC COUNTERBLOW HAMMER MODELS

Model	DG 16	DG 20	DG 25	DG 31.5	DG 40	DG 50	DG 63	DG 80	DG 100	DG 125	DG 140
Working capacity [kJ]	160	200	250	315	400	500	630	800	1,000	1,250	1,400
Impact frequency max. [per min]	50	45	45	40	40	36	36	32	28	25	25
Slide stroke max. [mm]	745	840	840	910	960	970	1,020	1,035	1,100	1,150	1,225
Slide depth [mm]	1,450	1,600	1,750	1,800	2,150	2,400	2,700	3,000	3,400	3,600	3,700
Clearance between guides [mm]	1,100	1,200	1,300	1,350	1,500	1,500	1,600	1,600	1,700	1,900	2,000
Total die height max.* [mm]	630	710	710	800	900	900	900	1,000	1,100	1,100	1,200
Total weight [t]	120	145	180	210	285	355	433	650	850	1,050	1,200

*) without dovetails Subject to technical modifications.

HOT FORGING - COUNTERBLOW HAMMERS

CASE STUDY

CUSTOMER: COMPONENTS INDUSTRY

THE REQUIREMENTS:

Economical production of large crankshafts with a component length up to four meters and weighing up to 3,000 kg each.

THE SOLUTION:

Schuler designed and manufactured a semi-automated forging line, based upon the DG 80H counterblow hammer. The entire forging line is equipped with an advanced control concept for optimizing the process parameters and material flow, based on an innovative logic function.

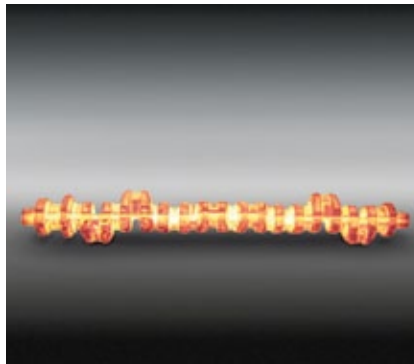

Production of large crankshafts up to 3,000 kg.



Counterblow hammer with a rated capacity of 800 kJ.

SEMI-AUTOMATED FORGING LINE WITH COUNTERBLOW HAMMER AND TRIMMING/CALIBRATING PRESS

- | | |
|----------------|----------------------------------|
| 1 Manipulator | 5 Drop machine |
| 2 Storage area | 6 Counterblow hammer |
| 3 Furnace | 7 Trimming and calibrating press |
| 4 Descaling | |

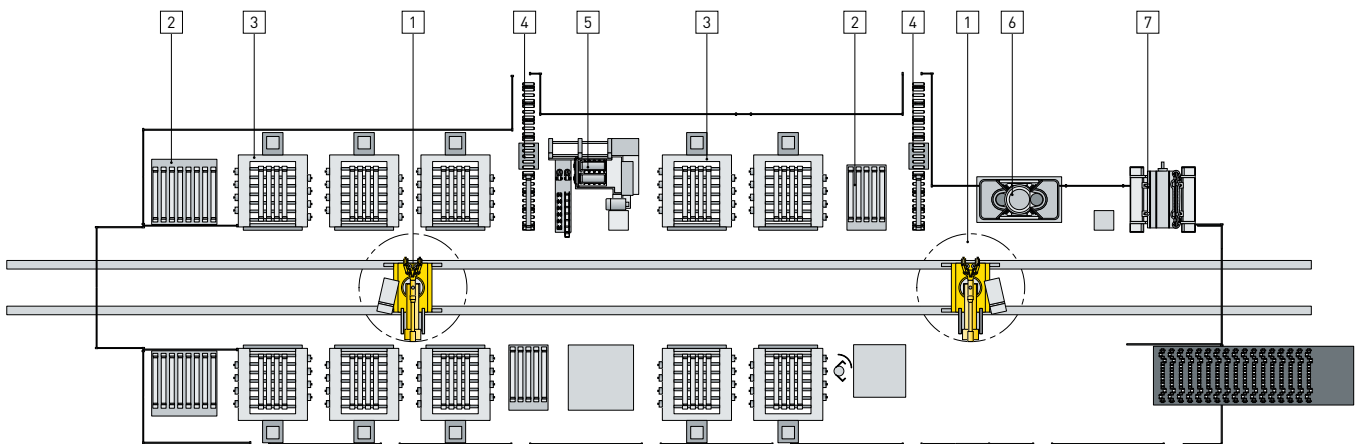

HOT FORGING

SCREW PRESSES WITH DIRECT DRIVE



Screw press with direct drive PZS 900f for manufacturing heavy forged parts.

**HIGH FLEXIBILITY.**

Thanks to almost 120 years of experience in building screw presses with continuous developments, there is practically no drop forging that cannot be manufactured using a screw press. As far back as 1936, the conventional friction drive was superseded by the

friction roller drive and, subsequently, direct drive. In 1963, reliable three-phase synchronous motors with rapid permitted switching frequencies opened the door to a new and ideal drive system for screw presses. In this direct drive, the torque from the drive motor is transmitted to the screw

without intermediate drive components, wear parts or energy losses. This drive concept represents the optimum design solution for a screw press drive – in terms of robustness, reliability, maintenance and efficiency.

THE ADVANTAGES

- Wide range of parts
- High repeat accuracy
- High reliability
- High flexibility
- Maximum efficiency

THE APPLICATIONS

- Forgings for the automotive industry and commercial vehicles such as crankshafts, axles, connecting rods or transverse links
- Surgical instruments as well as turbine components
- Fittings, flanges, hand tools, cutlery

ADDITIONAL EQUIPMENT

- Ejector in the bed and slide
- Die change systems
- Customer-specific solutions

HOT FORGING

SCREW PRESSES WITH DIRECT DRIVE

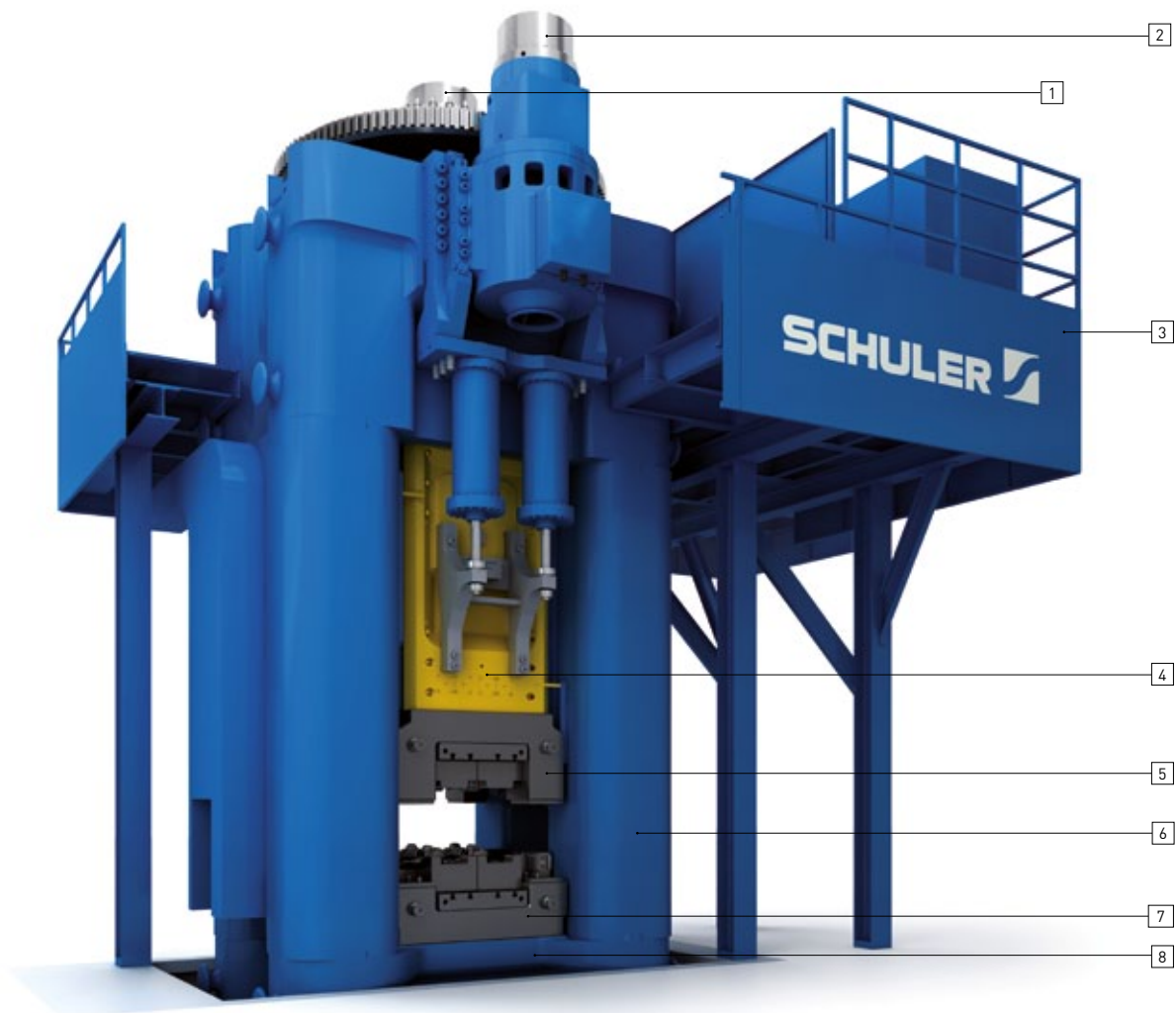

- 1 Flywheel
- 2 Motor
- 3 Crown
- 4 Slide

- 5 Upper die
- 6 Upright
- 7 Lower die
- 8 Bed

HOT FORGING

SCREW PRESSES WITH DIRECT DRIVE

SCREW PRESSES PA/PAR SERIES



Screw press type PAR 265f for manufacturing aluminum forgings.

The body of the press in the PA series is a monoblock design. An additional torque limiting clutch is used for overload protection in the PAR series. This system makes it possible to implement a higher working energy on the press, which is necessary for large forming distances. Small components made from non-ferrous metals and requiring high precision can be forged efficiently on type PA and PAR screw presses with direct drive.

OVERVIEW OF SERIES PA/PAR SCREW PRESS WITH DIRECT DRIVE MODELS

Model	PA 125	PA 140	PA 160	PA 180 PAR 180	PA 200 PAR 200	PA 225 PAR 225	PA 265 PAR 265	PA 300 PAR 300	PA 325 PAR 325	PA 360 PAR 360
Screw diameter [mm]	125	140	160	180	200	225	265	300	325	360
Continuously permitted press [kN]	2,500	3,200	4,000	5,000	6,400	8,000	11,000	14,000	16,000	21,000
Die-to-die blow force [kN]	3,200	4,000	5,000	6,300	8,000	10,000	14,000	18,000	20,000	26,000
Gross working capacity PA [kJ]	4.5	6.5	10	14	19	27	42	60	75	100
Gross working capacity PAR [kJ]	-	-	-	24	32.5	45	72	105	130	170
Stroke rate max. [min ⁻¹]	33	32	29	24	23	21	20	19	18	17
Distance bed – slide max. [mm]	620	670	730	790	850	940	1,050	1,150	1,250	1,350
Bed width [mm]	460	500	540	580	620	680	750	800	850	900
Bed depth [mm]	500	530	570	610	650	710	800	850	920	1,000

Subject to technical modifications.

HOT FORGING

SCREW PRESSES WITH DIRECT DRIVE

SCREW PRESSES PSM/PSH SERIES

The medium PSM/PSH series are produced as a two-piece casting held together by four tie rods. In the PSM series, once a defined forging force has been reached, the tie rods absorb surplus energy protecting the press against overload. In addition, the PSH series features a hydraulic overload protection system. This system allows the press to be equipped with a higher working energy, which is necessary when large forgings are involved. The series has a frequency drive. This not only allows precise control, but also delivers improved efficiency and better repetitive accuracy.



Screw press type PSH 4.450f for manufacturing parts of chain driven earth-moving machinery.

OVERVIEW OF SERIES PSM/PSH SCREW PRESS WITH DIRECT DRIVE MODELS

Model	PSM 265 PSH 265	PSM 300 PSH 300	PSM 325 PSH 325	PSM 360 PSH 360	PSM 400 PSH 400	PSM 450 PSH 450	PSM 500 PSH 500	PSM 560 PSH 560	PSM 630 PSH 630
Screw diameter [mm]	265	300	325	360	400	450	500	560	630
Continuously permitted press [kN]	11,000	14,000	16,000	21,000	26,000	32,000	40,000	50,000	64,000
Die-to-die blow force [kN]	14,000	18,000	20,000	26,000	32,000	40,000	50,000	63,000	80,000
Gross working capacity PSM [kJ]	65	100	120	160	210	315	400	500	700
Gross working capacity PSH [kJ]	90	140	170	225	300	420	560	700	1000
Stroke rate max. [min ⁻¹]	20	19	18	18	17	16	16	15	14
Distance bed-slide max. [mm]	780	860	920	1,000	1,080	1,200	1,300	1,450	1,460
Bed width [mm]	750	820	860	930	1,000	1,100	1,200	1,320	1,600
Bed depth [mm]	860	870	920	1,000	1,080	1,180	1,280	1,400	1,990

Subject to technical modifications.

HOT FORGING

SCREW PRESSES WITH DIRECT DRIVE

SCREW PRESSES PZS SERIES



Screw press with direct drive type PZS 900f for manufacturing heavy forgings.

The frame of PZS presses in this series is a four-piece casting held together by four tie rods. The drive comes from several motors linked via a bull gear to the external diameter of the flywheel. The press force is limited by a slipping clutch in the flywheel.

OVERVIEW OF SERIES PZS SCREW PRESS WITH DIRECT DRIVE MODELS

Model	PZS 710	PZS 800	PZS 900	PZS 1000	PZS 1120	PZS 1200	PZS 1325
Screw diameter [mm]	710	800	900	1,000	1,120	1,200	1,325
Continuously permitted press [kN]	80,000	100,000	128,000	160,000	200,000	230,000	280,000
Die-to-die blow force [kN]	100,000	126,000	160,000	200,000	250,000	290,000	360,000
Gross working capacity min. [kJ]	1,150	1,650	2,250	3,150	4,000	5,000	7,000
Gross working capacity max. [kJ]	2,200	3,000	4,000	6,000	6,800	8,500	10,000
Stroke rate max. [min ⁻¹]	10	9	9	8	8	7	4
Distance bed-slide max. [mm]	1,200	1,700	1,800	2,000	2,000	2,200	2,300
Bed width [mm]	1,600	2,050	2,100	2,400	2,400	2,600	3,100
Bed depth [mm]	2,000	2,000	2,200	3,000	3,000	3,000	3,700

Subject to technical modifications.

HOT FORGING - SCREW PRESSES WITH DIRECT DRIVE

CASE STUDY

CUSTOMER: MANUFACTURER OF HEAVY DUTY TRUCK ENGINE COMPONENTS

THE REQUIREMENTS:

System for automated production of truck crankshafts and truck front axles.

THE SOLUTION:

Schuler supplied a complete, fully automated forging line. A PZS 900f screw press with direct drive is used as the main forging machine. All necessary process steps such as rolling, pre-forming forging, finish forging, trimming, twisting and calibrating are accomplished in the line.



Screw press with direct drive type PZS 900f in operation.

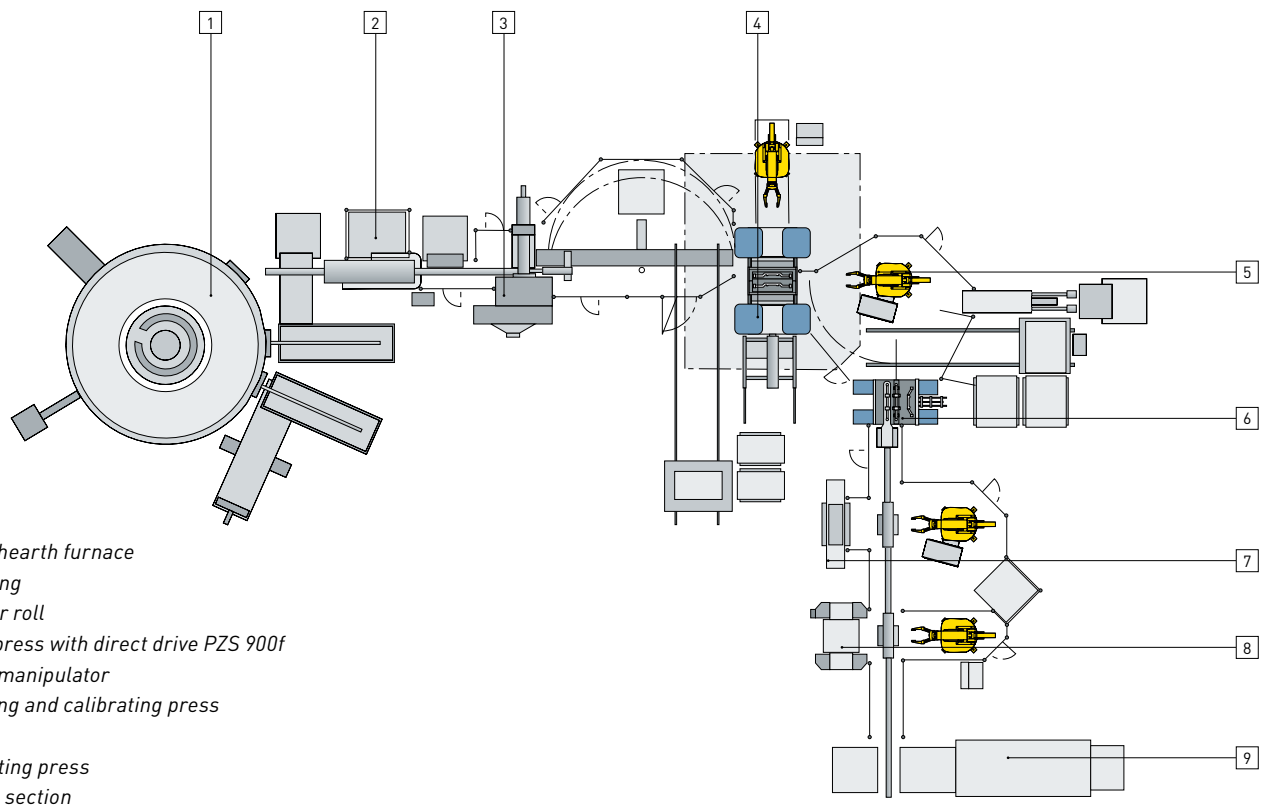

HOT FORGING

CRANK PRESSES



Crank press PK 3150.

**SPEEDFORGE.**

High-performance crank presses are particularly well suited to fully automated production of high volume forgings. The frame and drive system are designed for high load and production precision.

An extensive range of equipment including material feed, transfer system and finished part removal, spraying system and die change makes it possible to adapt the presses to various production jobs with ease. These presses can be efficiently used both for steel and non-ferrous materials.

THE ADVANTAGES

- High production speed
- Fully automated parts handling
- High production accuracy
- High rigidity
- Efficient series production

ADDITIONAL EQUIPMENT

- Ejector in the bed and slide
- Servo transfer
- Feeder
- Die change system
- Spraying system

THE APPLICATIONS

- Chassis components
- Flanges
- Drive components
- Bearing races
- Gear blanks

HOT FORGING

CRANK PRESSES

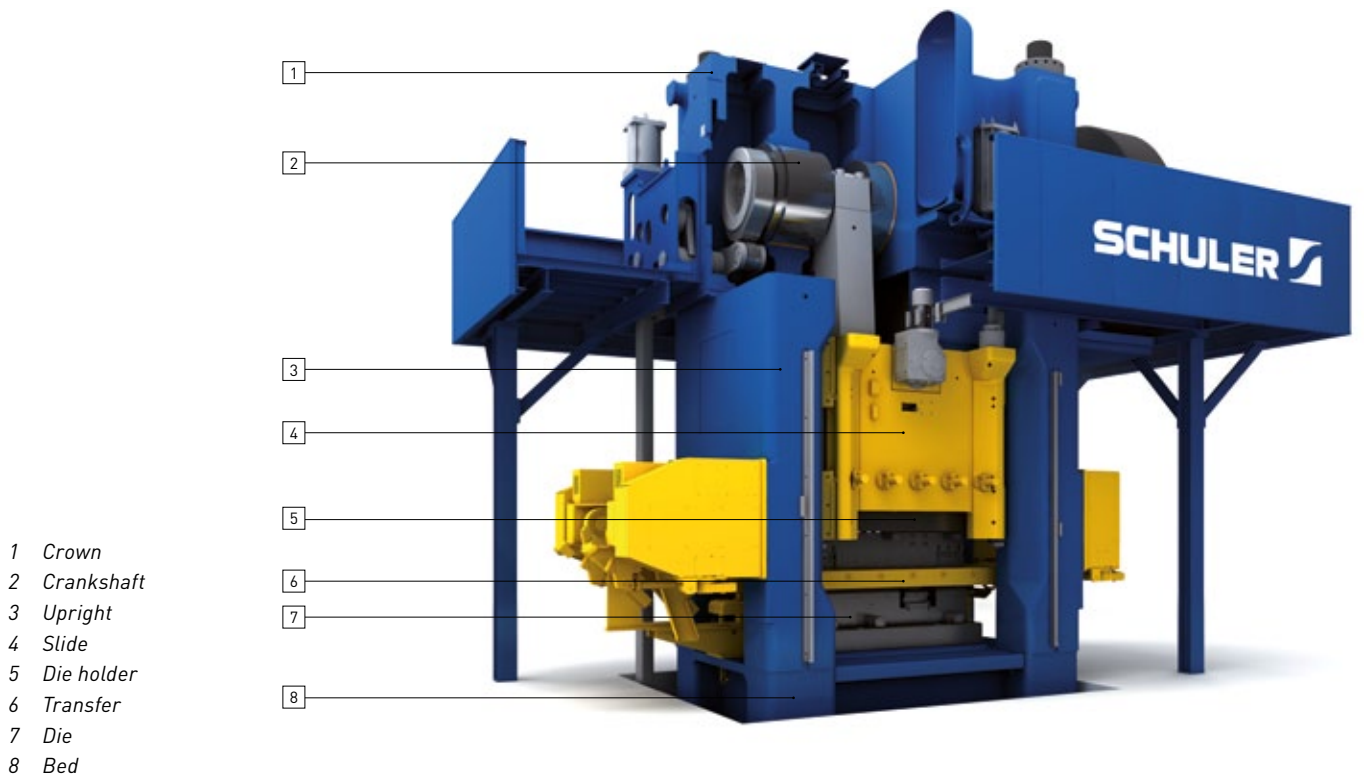

- 1 Crown
- 2 Crankshaft
- 3 Upright
- 4 Slide
- 5 Die holder
- 6 Transfer
- 7 Die
- 8 Bed

OVERVIEW OF CRANK PRESS MODELS

Model	PK 1250	PK 2000	PK 3150	PK 4000	PK 5000	PK 6300
Nominal force [kN]	12,500	20,000	31,500	40,000	50,000	63,000
Stroke rate continuous [1/min]	70	65	60	60	50	40
Working capacity single [kJ]	180	320	550	750	1,000	1,300
Ram stroke [mm]	300	300	400	425	450	450
Ram adjustment [mm]	15	20	25	20	20	20
Shut height [mm]	850	1,100	1,500	1,600	1,700	1,700
Bed depth [mm]	1,050	1,500	1,390	1,450	1,500	1,600
Bed width [mm]	1,280	1,640	2,170	2,200	2,250	2,300

Subject to technical modifications.

HOT FORGING

CRANK PRESSES WITH SERVODIRECT TECHNOLOGY

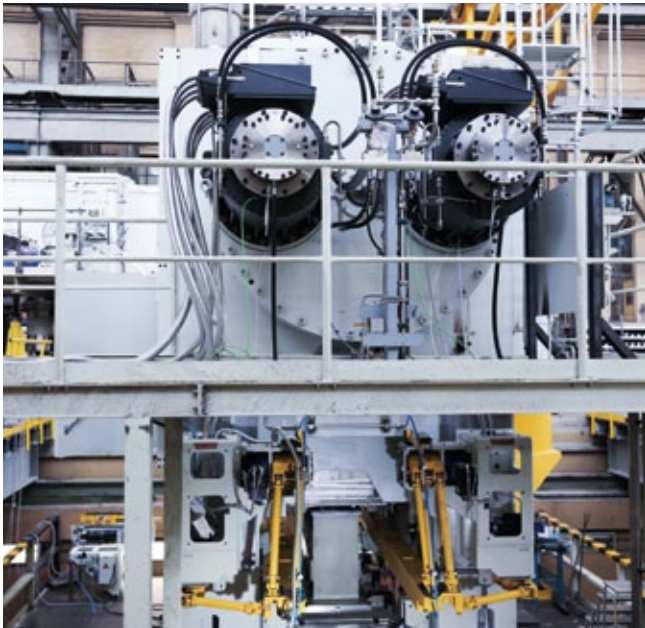

Installation of a forging press with ServoDirect Technology.

DIRECT DRIVE.

In forging presses with ServoDirect Technology, several torque motors act on a main shaft via a step-down gear unit. These types of presses are suitable for single-stroke operation as well as forging in continuous operation.

THE ADVANTAGES

- High efficiency with optimum productivity levels
- Great flexibility due to adaptable slide movements
- Rigid configuration with triple bearings for the crankshaft
- Short pressure contact times and low heat input
- Wear-free single-stroke operation is possible
- Immediate access to the die installation space, for example in tryout mode
- Station to station part handling with minimal speed

Stroke

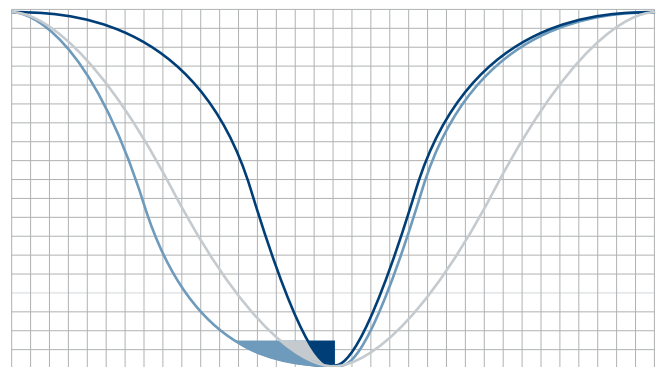

0 Pressure contact time Time

- Movement profile of servo press, e.g. for steel
- Movement profile of servo press, e.g. for aluminum
- Movement profile of conventional crank drive

ServoDirect Technology allows the slide motion to be programmed individually.

The stroke rate and forging speed can be optimally adapted to the part. Production output levels are increased by shorter pressure contact times and a corresponding lower heat input into the dies.



- 1 Crown
- 2 Servo motors
- 3 Planetary gear
- 4 Upright
- 5 Slide
- 6 Die holder
- 7 Transfer
- 8 Die
- 9 Bed

HOT FORGING – CRANK PRESSES WITH SERVO DIRECT TECHNOLOGY

CASE STUDY

CUSTOMER: AUTOMOTIVE MANUFACTURER

THE REQUIREMENTS:

System for fully-automated manufacturing of gear blanks with a high output level.

THE SOLUTION:

Schuler provided a complete production line, comprising parts feed, induction heating system, crank press PK 1600 with ServoDirect technology, mechanical ejectors, and electronic transfer. Die holders, dies, and the die change system round off the scope of supply. On the forging line, gear blanks are manufactured using a manufacturing process which is free of burrs with a production output of 35 parts/min. and five forming stages.



Crank press PK 1600 with ServoDirect technology.



Annealing forging part in the die.

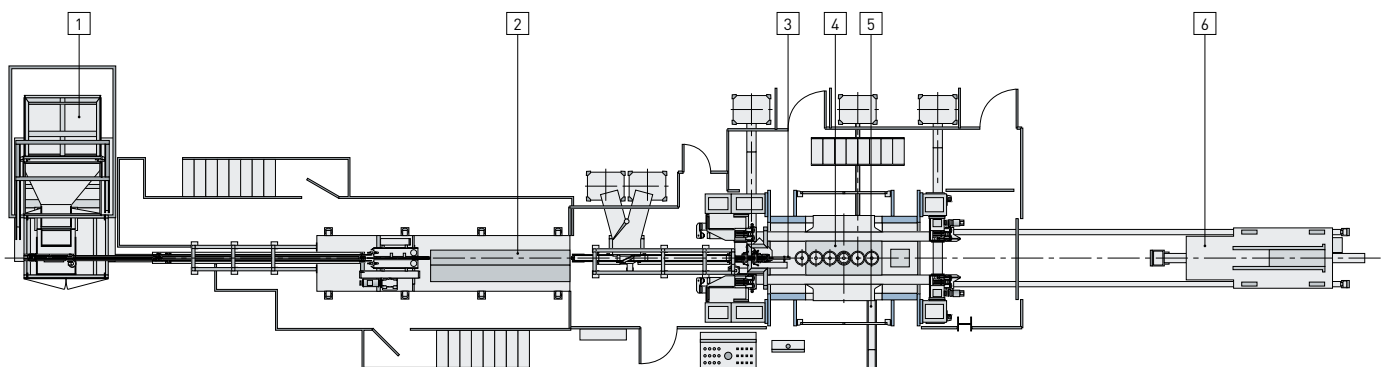

1 Parts feed

2 Induction furnace

3 Feeder

4 Crank press with automation

5 Conveyor for finished forged parts

6 Die change

HOT FORGING

PRESS CONTROL SCHULER FORGE CONTROL SYSTEM (FCS)



Straightforward operation with graphic user interface.

The Schuler FCS control system represents the latest development in control systems for screw presses, forging hammers, crank presses and upsetter. It has been developed especially for forging machines, and combines the latest features for high flexibility and high accuracy in controlling machine parameters.

Depending on the machine and application, the standard functions include a wide range of stroke control options or impact program specifications, energy and part thickness measurement, control loops for energy and TDC position, as well as documentation functions for die and production data.

THE ADVANTAGES

- Ease of operation because of uniform graphical user interface with touch screen
 - Monitoring functions for parameters affecting quality, such as impact energy, part thickness, impact force, part temperature
 - Required impact energy can be applied precisely
 - Visualization in almost every customer's language
 - Access to machine documentation, circuit diagrams and fluid diagrams
 - Remote maintenance and diagnosis
 - Interfaces for external data storage as well as print function, including integration in a customer's network
 - Control loops to ensure that process parameters are observed, especially for screw presses
-



Monitoring of the force/motion profile with envelope curve.



Thickness measurement including Gaussian standard distribution curve.



Forge Control System for monitoring the complete forging line.

ADDITIONAL EQUIPMENT

- MDA-Machine Data Acquisition
- Barcode scanner
- Pyrometer for part temperature
- Central control for forging cells with central data storage and data management
- Interlinking interfaces and, if required, control functions to customer's forging peripherals
- Energy feedback into the power system when operating screw press with frequency inverter
- Heating with control loops for top and bottom
- Customer-specific special functions

HOT FORGING

UPSETTER WITH SERVO DIRECT TECHNOLOGY



Upsetter with ServoDirect Technology in production.

MAXIMUM PRODUCTION OUTPUT.

The upsetter with ServoDirect Technology permits maximum production output and makes it possible to optimize forging parameters for the material in the forging process. The upsetter with ServoDirect Technology is operated with two separate servomotors. At the same time, the movements of

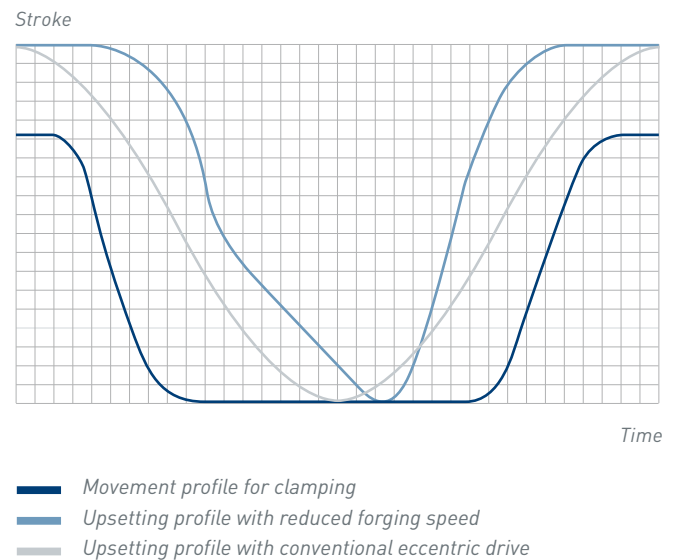

ServoDirect Technology allows the clamping and upsetting movements to be programmed individually.

the clamping and upsetting slide can be set independently from one another. This offers the advantage of adapting the movement kinematics flexibly to the forging process. Furthermore, the shortest pressure contact times can be achieved in the clamping and upsetting work sequence.

THE ADVANTAGES

- Independent movements of the clamping slide and the upsetting slide due to two servo drives
- High output performance
- Double overload protection with force and torque limitation
- Energy efficient ServoDirect Technology
- Complex components

HOT FORGING

HYDRAULIC OPEN DIE FORGING PRESSES



Hydraulic open die forging press from the MHFU series.

PRESS SYSTEMS.

According to the requirements Pull Down (MHFU-series) as well as Push Down concepts (MHFT-series) in two or four column design can be provided. Beside the need of a deeper foundation pull down presses are offering plenty advantages. Less tendency of swing, clear forging area with excellent accessibility and drive system below floor level is protected against contamination.

OVERVIEW OF HYDRAULIC OPEN DIE FORGING PRESS MODELS

Model	MHFT8 MHFU8	MHFT10 MHFU10	MHFT12.5 MHFU12.5	MHFT16 MHFU16	MHFT20 MHFU20	MHFT30 MHFU30	MHFT45 MHFU45	MHFT60 MHFU60	MHFT80 MHFU80	MHFT100 MHFU100
Press force [MN]	8.0	10.0	12.5	16.0	20.0	30.0	45.0	60.0	80.0	100.0
Die space [mm]	2,200	2,200	2,500	2,850	3,400	4,000	5,000	6,000	7,000	8,000
Ram stroke [mm]	1,000	1,000	1,200	1,350	1,600	1,800	2,400	3,000	3,500	4,000
Passage width [mm]	1,400×750	1,600×850	1,800×1,000	2,000×1,100	2,300×1,200	2,500×1,400	3,500×1,550	4,000×1,800	4,500×2,000	5,000×2,200

Subject to technical modifications. Hydraulic open die forging presses up to 150 MN are available upon request.

HOT FORGING

HYDRAULIC OPEN DIE FORGING PRESSES



Open Die forging press in underfloor MHFU design.

PROVEN DRIVE SYSTEM.

The Modified Sinusoidal Direct drive System (PMSD) gives presses an extremely high cycling frequency in a shock free manner, because there are no operating valves in the main lines of the system. This drive and control system is designed for low maintenance requirements and high availability.



Hydraulic open die forging press with two manipulators.

TURNKEY SOLUTIONS FOR OPEN DIE FORGING.

Manipulators connected to the forging press round off the equipment of modern forging systems with optimized productivity. They enable swift and precise positioning of the forging part as well as automatic operation and ensure a high degree of precision and repeatability. Manipulators are ideally suited as supports when manufacturing heavy forming parts using cranes. Turntables, which can be lifted, between the manipulator and press support loading by mobile loaders and are used to turn forming parts.



Example of a complex hammer forging part.

In the field of hammer forging, Schuler has extended its capabilities by forming a strategic partnership with Pahnke, a well-known name with a great deal of experience under its belt in the forming industry. We offer our customers a wide range of products and

THE ADVANTAGES

- High productivity
- Energy efficient drive technology
- Excellent uptime and availability

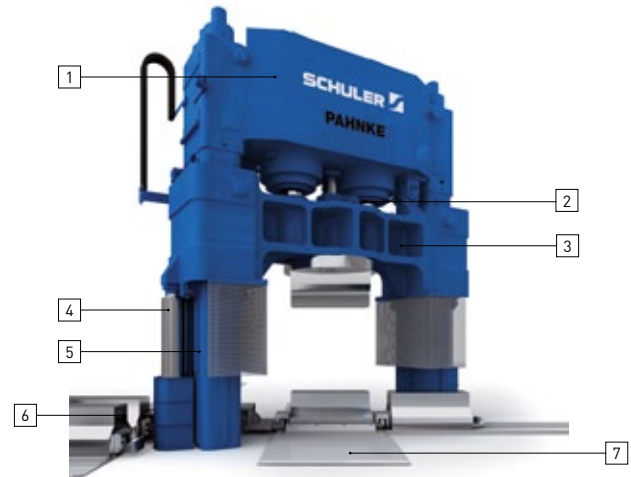

- | | |
|-------------------|------------------|
| 1 Crown | 5 Upright |
| 2 Main cylinder | 6 Tool magazine |
| 3 Slide | 7 Moving bolster |
| 4 Return cylinder | |

services through to implementing complex major projects. We want to give our customers the competitive edge, by providing highly efficient production systems for manufacturing hammer forging parts to a high degree of quality.

THE APPLICATIONS

- Slabs
- Different kinds of shafts
- Sleeves
- Rings
- Special forgings

HOT FORGING

HYDRAULIC FORGING PRESSES



Hydraulic forging press with 140,000 kN press force.



Multi-station closed die forging press with 6,300 kN press force.

HIGH FORCES AND LONG WORKING TRAVEL DISTANCES.

Hydraulic forging presses are used wherever high forces and long working travel distances are required. This is revealed in numerous special applications up to press forces of 300,000 kN and working travel distances of 4 m.

Examples include hot forging presses, piercing presses and presses for partial forging of fittings and thick-walled pipes.

OVERVIEW OF HYDRAULIC FORGING PRESS MODELS

Model	MH 500	MH 630	MH 800	MH 1000	MH 1600	MH 2000	MH 2500	MH 3000	MH 3500
Press force [kN]	5,000	6,300	8,000	10,000	16,000	20,000	25,000	30,000	35,000
Number of stations	1-3	1-3	1-3	1-3	1-4	1-4	1-4	1-4	1-4

Model	MH 4000	MH 5000	MH 6000	MH 7000	MH 8000	MH 9000	MH 10000	MH 12000	MH 14000
Press force [kN]	40,000	50,000	60,000	70,000	80,000	90,000	100,000	120,000	140,000
Number of stations	1-4	1-3	1-3	1-4	1-4	1-4	1-4	1-4	1-4

Subject to technical modifications. Different tonnages are available upon request.

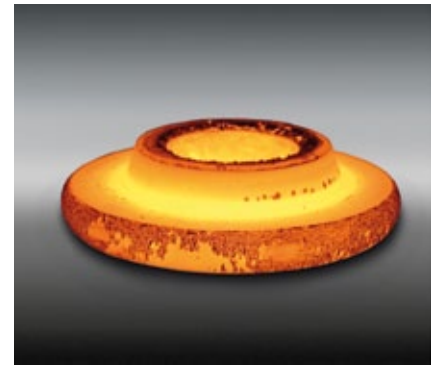
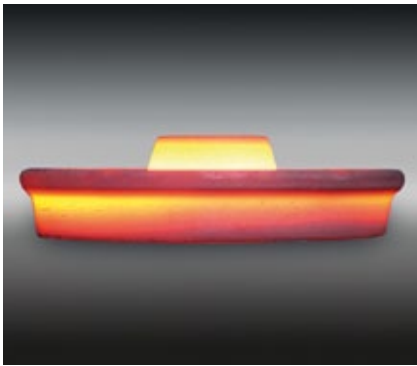

FORGING LINES WITH HYDRAULIC PRESSES.

The working sequences before and after the actual forging are frequently performed on hydraulic presses. On hydraulic pre-form presses, pre-forms are generated so that there will be a mass distribution appropriate for the die. Having a pre-form with a good

structure reduces the amount of material used and also reduces the forming forces required during forging. The die life is improved. Following die forging, the flash is trimmed off and any required piercing and coining work is performed on hydraulic trimming and calibrating presses.

These working sequences can either be combined in one die or performed consecutively in several stations. Hydraulic presses are the main units used for manufacturing complex parts such as ring blanks, aluminium wheels or railway wheels.

THE APPLICATIONS

- Aluminum wheels
- Railway wheels for cars
- Railway wheels for engines
- Fittings for pipelines
- Thick-walled pipes
- Rail ends
- Large flanges and brake disks (pre-forming)
- Crank shafts (calibrating)
- Axle parts (calibrating)
- Seamless rings as the precursor for:
- Bearing shells
- Crown gears
- Flanges
- Blade carriers for jet engines
- Various highly stressed structural elements

HOT FORGING

HYDRAULIC FORGING PRESSES

LINES FOR FORGING AND ROLLING RAILWAY WHEELS



Hydraulic press for forging railway wheels.



The Schuler wheel roller.

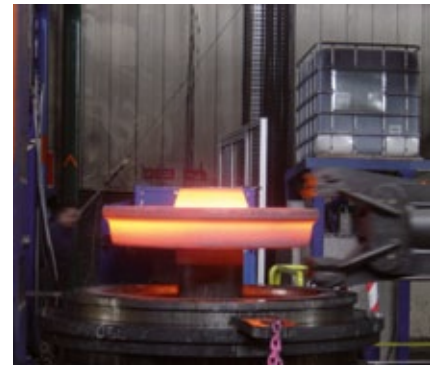

FORGING AND ROLLING RAILWAY WHEELS.

Railway wheels are manufactured in three forging stages before they are processed further with machining. First, the heated billet is pressed into a disk-shaped pre-form on a pre-form press. Next, this blank is rolled into the shape of a wheel on a rolling machine. Last, the rolled wheel is shaped in a calibrating press and a hole is pierced in the hub. Hydraulic presses with press forces up to 100,000 kN are used for pre-forging the wheels. As a rule, press forces from 20,000 to 50,000 kN are required for shaping and piercing.

THE ADVANTAGES

- High press forces achieve more accurate pre-forging, reducing rolling work
 - Weight savings due to greater accuracy
 - High output
-

HOT FORGING

HYDRAULIC FORGING PRESSES

HYDRAULIC PRESSES FOR FORGING RING BLANKS



Multi-station hydraulic ring blank press with 35,000 kN press force.

HYDRAULIC PRESSES FOR FORGING RING BLANKS.

When manufacturing seamless rings, the first forging operation is forging the ring blank. Ring rolling lines turn these into the precursors for bearing shells, crown gears, flanges, turbine disks for jet engines and various highly stressed structural elements.

Hydraulic presses are particularly well suited for forging ring blanks: High forces, long strokes and an unlimited rated capacity are the features needed for efficient ring blank forging. Either highly flexible lines or multi-station processes with optimized output are used, depending on the depth of the product range and/or the required output rate. Centering devices, swivel arms, robots and manipulators guarantee suitable parts and die handling.

THE ADVANTAGES

- High forces for extremely large parts
- High flexibility and high output rates
- Proven press concepts
- Different forging processes adapted to the parts
- Coordinated die processes, in-house die and process expertise

HOT FORGING

HYDRAULIC FORGING PRESSES

HYDRAULIC PRESSES FOR FORGING RING BLANKS



Hydraulic ring blank press with 30,000 kN press force.



Hydraulic ring blank press with 40,000 kN press force.



Forging of a ring with symmetrical fiber course.

PROCESSES DEPENDENT ON THE PRODUCT.

The required part geometry and a suitable grain flow are provided by different forging processes. Ring blanks for simple parts are manufactured by open die upsetting followed by pre-piercing and piercing. Complex geometries are achieved by forging and pre-piercing in a die. Pre-piercing guarantees a symmetrical grain flow in the part and has a positive effect on the mechanical properties of the finished product. Each process requires a precisely configured line with the necessary level of flexibility for the required output rate.

The short cycle time of the press allows the ring blank to be further processed before it cools. Different materials present the forging line with different challenges. Low-alloy steels can be formed relatively easily, while “exotic” materials such as nickel-based alloys, Inconel, titanium and aluminum alloys require process parameters that can be adjusted or even varied during the forging operation, such as adjustable profiles for the forging speed.

HOT FORGING – HYDRAULIC FORGING PRESSES

CASE STUDY

CUSTOMER: MANUFACTURER OF OIL AND GAS PIPELINES

THE REQUIREMENTS:

System for forging parts for the oil and gas industry.

THE SOLUTION:

Schuler provided its largest universal forging press to manufacture components for the oil and gas industry. The dual forging press with a press force of 2 × 140,000 kN enables previously cast parts to be cost-effectively manufactured with a diameter of up to 2,500 mm. The press which weighs in total over 4,000 tons, is 22 m high above ground and 9 m deep underground, and is ideally suited to various forging methods: Valve housing is manufactured in a two-stage retraction and upsetting process. The high press



Hydraulic dual forging press with 2 × 140,000 kN press force.



Dual forging die for large valve housing.

forces and degree of precision ensure optimum results here. Rings are forged using centering manipulators and swivel arms. Various dies are also arranged on the moving bolster for this purpose.

A drawing cushion housed in the press bed enables manufacturing of large T-pieces. Upsetting, reducing, cupping, and finishing – the numerous press functions enable various complex parts to be manufactured.

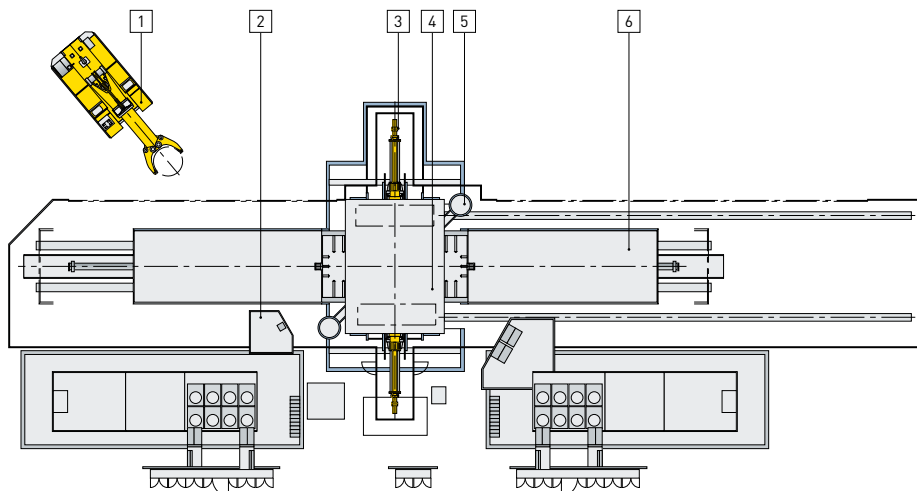

- 1 Manipulator
- 2 Control panel
- 3 Centering manipulator
- 4 Hydraulic forging press
- 5 Swivel arm
- 6 Moving bolster

HOT FORGING

HYDRAULIC FORGING PRESSES

FORGING LINES FOR FOR MANUFACTURING ALUMINUM WHEELS



Turnkey system for manufacturing aluminum wheels.

FORGING ALUMINUM WHEELS.

Weight savings achieved in the driveline are leading to more energy efficient vehicles. In addition, reducing the wheel weight in trucks can allow for a payload increase of up to 500 kg, depending on the number of wheels, for the same gross vehicle weight. In addition, the ability to polish the surface to a mirror-like finish makes the hearts of some truck drivers beat faster. These requirements are met by forged aluminum wheels. Hydraulic presses with high press forces make it possible to forge aluminum wheels with superior properties: Improved mechanical properties, lighter weight, good chemical resistance, and almost unlimited design options.

Turnkey systems including the presses, a saw for the billets, heaters, automation and die change devices make it easy to start forging aluminum wheels, or to extend an existing production facility. Line controllers make sure the complex systems operate reliably.

THE ADVANTAGES

- Concentrated high press forces
 - Proven press concepts
 - High precision and quality of forged wheels
 - High output rates
 - Forging processes adapted to the part geometry
 - Complete lines from a single source
-



Forging line for manufacturing aluminum wheels.



Forged truck wheel.



Tool sequence for car aluminum wheels.

ADAPTED FORGING PROCESSES FOR THE PRODUCTION OF ALUMINUM WHEELS.

The design and geometry of the forged wheel, as well as the required quantity, influences the type of system selected for production. Simple wheel geometries without a forged rim face, such as truck wheels, are forged in one station. The following station carries out the trimming and flaring of the rim. A similar process is used for small quantities, in which the design of the rim face is completed by machining.

For rims with a profiled face, press lines comprising typically three to four presses are used. The parts are either forged with one heat in three to four stations or with intermediate heating. Single or double-action presses make it possible to forge the rim face precisely. The surface is either left unfinished (as forged) or machined, depending on the quality required.

HOT FORGING - HYDRAULIC FORGING PRESSES

CASE STUDY

CUSTOMER: SUPPLIER TO AUTOMOTIVE AND TRUCK INDUSTRIES

THE REQUIREMENTS:

Line for economical aluminum wheel manufacturing for cars and pickups.

THE SOLUTION:

Schuler supplied two manufacturing cells, each based on presses with 70,000 kN press capacity. The aluminum wheels are forged in one stroke. High-performance ejectors are installed in bolster and slide to make sure the parts are unloaded safely from the die. The wheels are then flared on a press with 8,000 kN press capacity. The proper operating conditions of the dies are ensured by a lubricating and cooling system consisting of a lubricant conditioning device and linear manipulator with rotary head. Both oil-based lubricants and water-based lubricants can be



Hydraulic press with 70,000 kN press capacity in production.



Forged part and finished wheel.

used. Part handling inside the cell is done by a six-axis robot designed for forging. Short cycle times are achieved by double grippers. Hydraulic clamps with internal cooling and a tandem die change cart are provided for quick and safe die changes.

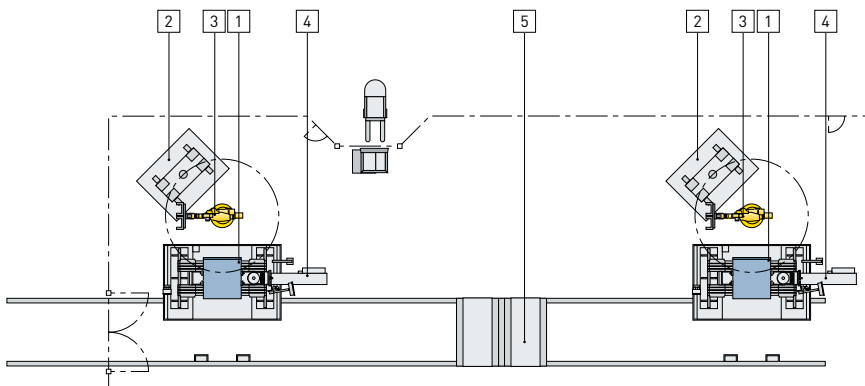

- 1 Hydraulic forging presses with 70,000 kN capacity each
- 2 Flaring presses with 8,000 kN capacity each
- 3 Robot with double-tooling
- 4 Lubrication manipulator with rotating head
- 5 Die change cart

HOT FORGING

RING ROLLER

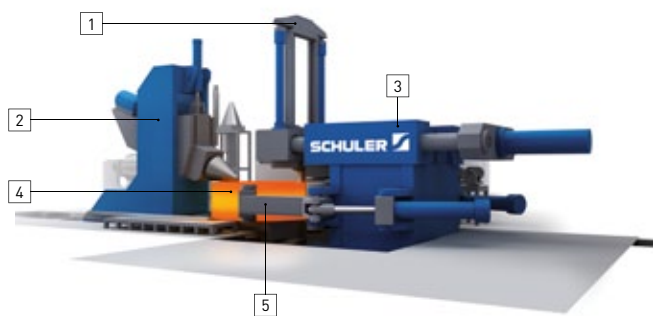

- 1 Mandrel lifting equipment
- 2 Axial frame
- 3 Radial frame
- 4 Ring
- 5 Centering arms

Production of small and large rings on a single Schuler ring roller.

TAILOR-MADE FORGING AND ROLLING PROCESSES FROM SCHULER.

These machines make it possible to manufacture seamless rings according to their specific required properties.

THE ADVANTAGES OF RING ROLLER

- Reliable technology proven for decades in forging environments
- Special design for production of small and large rings on the same ring roller
- Quick tool change solutions to reduce machine downtime

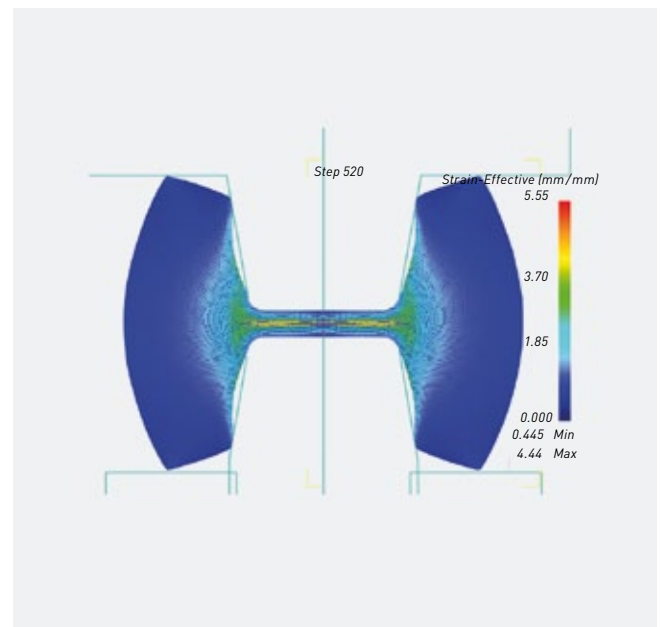

Ring blank with symmetrical fiber orientation.

The seamless rings are used on engine casings, bearing shells, blade carriers and different structural elements. Advanced features offered by Schuler, such as simultaneous punching, achieve optimized flow of special products.

HOT FORGING

WHEEL ROLLER

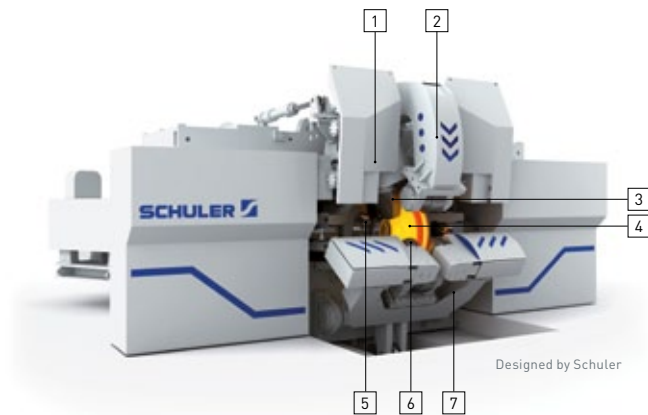

TURNKEY MACHINES FOR MANUFACTURING WHEELS EFFICIENTLY.

Schuler special equipment configurations can fulfill all customer requirements for a complete process starting from the continuous casted material to the finished wheel for the most economic production of wagon, locomotive, and high speed wheels. High press forces linked to precise control systems ensure low material consumption.

- | | |
|-----------------------|-------------------------|
| 1 Tapered roller unit | 5 Bar roller |
| 2 Upper centering arm | 6 Lateral guide rollers |
| 3 Main roller | 7 Lower centering arm |
| 4 Railway wheel | |

Schuler wheel roller optimized for extended tool life.

THE ADVANTAGES OF WHEEL ROLLER

- High accuracy due to rigid machine design
- All tool axles driven (main and support drives)
- Continuous cooling during loading /unloading for less wear and increased tool life
- Internal torque zeroed for less abrasion and extended tool life
- Extended life time of shafts and bearings due to well-sized units

HOT FORGING - WHEEL ROLLER

CASE STUDY

CUSTOMER: NEW SUPPLIER FOR RAILWAY INDUSTRY

THE REQUIREMENTS:

Production of forged wagon, locomotive and high speed wheels with an output up to 72 wheels per hour, with minimum material consumption and high availability.

THE SOLUTION:

Schuler supplied the complete forging line with both process and die technology. Large hydraulic presses, designed with external billet centering and special guiding in the tooling, prepare wheels for the newly developed wheel roller to produce precision forged high-speed rail wheels. Quick and easy change-over of the



Schuler Wheel Roller MHRV 180/80.

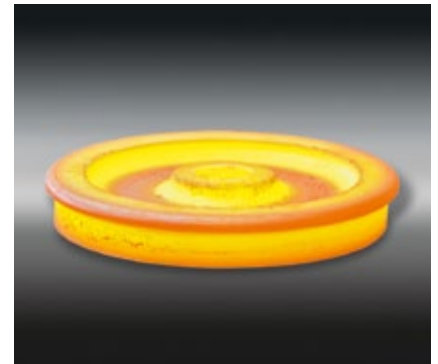

Railway wheel after rolling.

entire line is supported by double die change carriages. The line control includes integrated process simulation software to automate the sequence of operations of the railway

wheels. This, in combination with the high press forces, leads to approximately 10% reduction in material consumption as compared to current systems in the market.

ROBOT AUTOMATED COMPLETE SYSTEM FOR FORGING AND ROLLING RAILWAY WHEELS

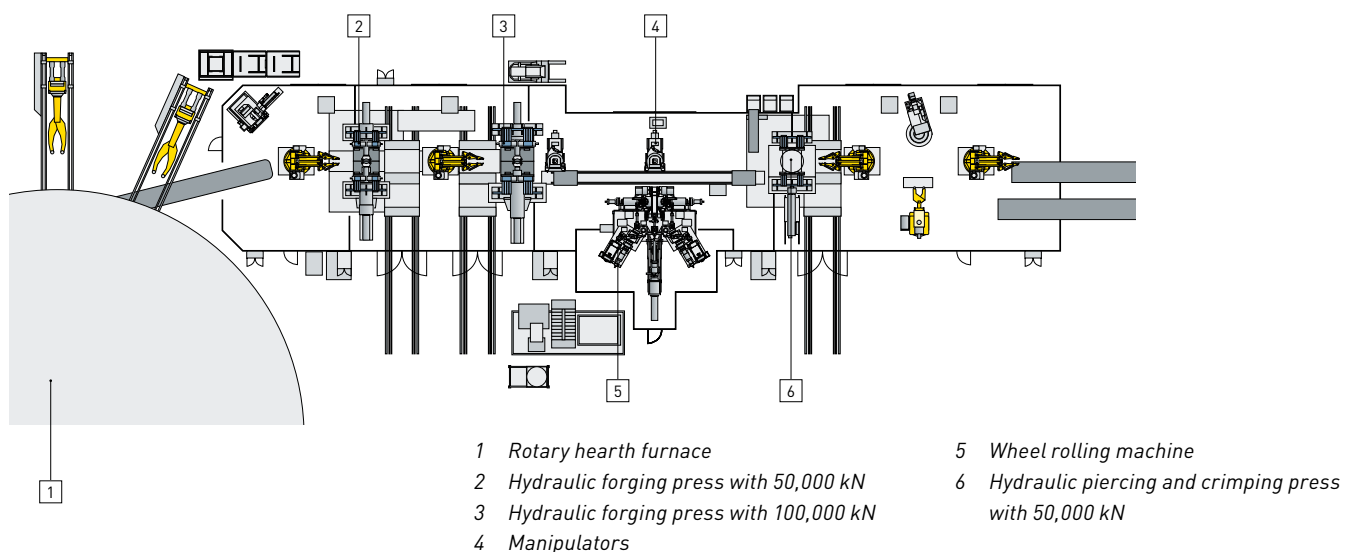

06

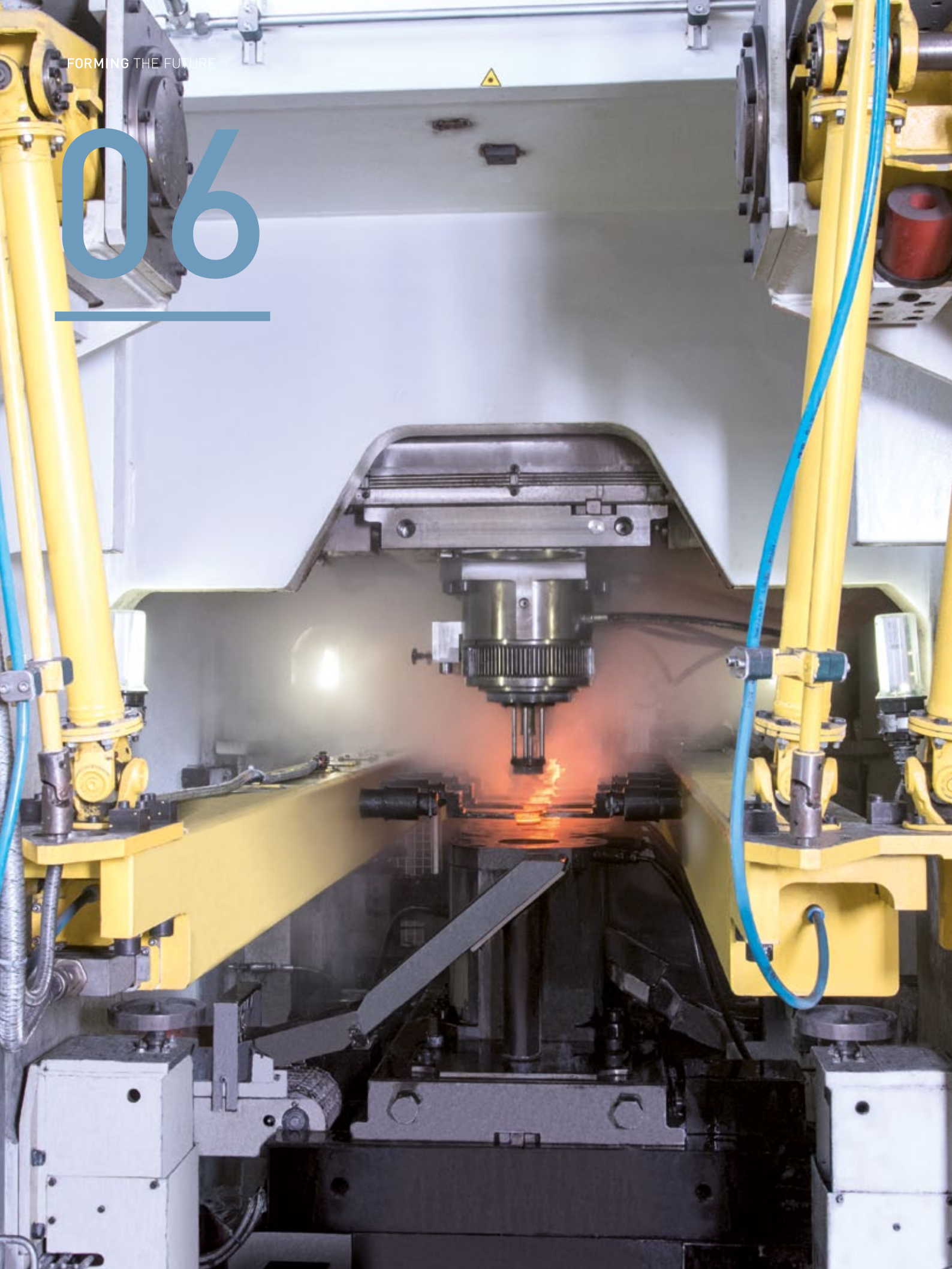

AUTOMATION FROM SCHULER

From the individual press, to forging hammers, through to the complete press line: As a system supplier, we automate your forming systems in an intelligent, yet practical manner. Our automation solutions are perfectly tailored to the temperature ranges of cold, warm, and hot forging. This allows you to increase the capacity of your production lines in an efficient and cost-effective way.

The automation solutions offered by Schuler have been rounded off to include optimum maintenance and a global service, thereby ensuring performance across the entire line – with reliable production processes and a significant reduction in part costs.

TRANSFER SYSTEM SOLUTIONS	86
ROBOT AUTOMATED HAMMER LINES	88
ROBOT AUTOMATED PRESS LINES	89

SCHULER ONLINE



Do you want to find out more about automation for forging?

Visit www.schulergroup.com/automation_forging to find more detailed information.

From there, you can also download various brochures on this topic.

AUTOMATION FROM SCHULER

TRANSFER SYSTEM SOLUTIONS

FLEXIBLE AND ACCURATELY POSITIONED TRANSFER SYSTEM SOLUTIONS.

The Schuler tri-axis servo transfer is the reliable solution when maximum positioning accuracy is called for. Electrically-driven and servo motor-driven gripper rail systems form the basis for this concept. They not only enable the motion sequence to be freely programmed and therefore optimally adjusted to the forming process. Even the times for the cooling and lubrication of forming tools can be directly adjusted to the process. If the Tri-axis servo transfer is also combined with a servo press drive, an optimized forming, motion, spray and cooling process is also achieved for optimum results. All grippers are equipped with quick disconnect coupling systems which enable fast replacement without any long production downtimes.



The Double Beam ensures a high output level and is available as a standard or encapsulated version.

An efficient, versatile solution for all applications. The Schuler Double Beam offers highly efficient parts transfer, regardless of whether cold, warm or hot forging is involved. Available in two versions, as standard or encapsulated design, the Schuler Double Beam stands out with its high output level. Parts handling is performed with passive grippers.



The robust Mono Beam is perfectly suited to all requirements.

The robust choice for warm and hot forging. The areas of application of the Schuler Mono Beam include warm and hot forging. The encapsulated transfer is highly reliable and is ideally suited to all requirements, thanks to its robust design. The parts handling works with hydraulic active grippers – guaranteeing extremely economical parts transport.

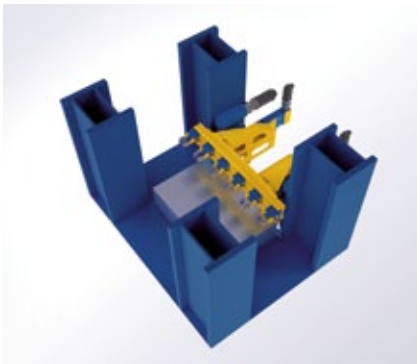

The Compact Mono Beam stands out from the crowd with its compact design and high-performance active grippers.

The compact choice for cold forging.

Developed for parts transfer in cold forging, the Schuler Compact Mono Beam proves advantageous on various levels. It features a highly compact, space-saving design which can even be used in confined spaces. The parts are transported using a parts handling device with hydraulic active grippers, which continually ensure a high output level.

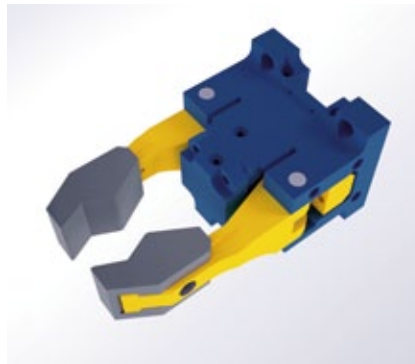

The active grippers are suitable for handling round parts, while passive grippers are used for bottle-shaped parts.

The grippers – these specialists lend a hand when particular tasks are called for. Optimized in line with specific requirements, the transfer systems work with various grippers. For instance, the passive grippers used in the Double Beam are ideally suited to handling bottle-shaped and cylindrical parts. The fast replacement option keeps change times to a minimum. If required, passive grippers can also be extended to form turn-over grippers. In contrast, active grippers are used for the Compact Mono Beam and Mono Beam, which are typically designed for handling bottle-shaped parts. They can also be optionally extended to form rotary grippers.

THE ADVANTAGES:

- Tri-axis servo transfer for maximum positioning accuracy
- Extremely economical, due to fast parts transport
- Servo drive enables freely programmable motion sequences as well as optimized times for cooling and lubrication of forming dies
- Available with active or passive grippers, depending on the requirements of the parts geometry
- Quick disconnect coupling system for fast gripper replacement

AUTOMATION FROM SCHULER

ROBOT AUTOMATED HAMMER LINES



Parts transport and forging using two robots.



The patented special gripper prevents vibration couplings during hammer forging.



The hammer line is automated with three robots for optimum processes.

High-performance, thanks to robot automation. Forging hammers can be efficiently automated using the robots provided. The results: an increased level of output and improved product quality, as well as increased safety and reliability throughout the entire production process. Depending on the parts geometry and cycle time requirements, two or three robots are used to automate the hammer. These robots are equipped with a special patented gripper, which prevents the robots from being coupled as a result of vibrations caused by the forging blows of the hammer.

In this way, robot automation creates further potential to increase performance, cost effectiveness, and productivity – particularly in combination with the new hammer and linear drive.

AUTOMATION FROM SCHULER

ROBOT AUTOMATED PRESS LINES



Optimum accessibility and flexibility through automation with suspended robots.



Screw press PZS900 automated with suspended robots.



Robot-automated screw press.

Precisely tailored to the requirements. Automation of forging lines with screw or crank presses provides multiple benefits. In addition to the higher level of output, the degree of process reliability and therefore process safety can be significantly increased.

In doing so, robot automation takes all the special features of a production process into consideration. As such, you can decide whether the robots are positioned on the ground or are suspended from above. If parts are to be transported over long distances, robots suspended from above can be easily equipped with an additional linear axis. This not only enables precise positioning of the forging parts, but also means that spacers are no longer required.

The robots work with special hydraulic grippers which have been developed to safely pick up and deposit forging parts, including heavy ones. To ensure the seamless monitoring of the parts transport, all grippers are also equipped with part sensing equipment.

FORMING THE FUTURE

07



AT A GLANCE

LOCATIONS AND SCHULER SERVICE

SCHULER WORLDWIDE – FORMING THE FUTURE.

As the technological and global market leader in forming technology, we offer presses, hammers, automation solutions, dies, process know-how and services for the entire metal-forming industry. Its clients include automotive manufacturers and their suppliers, as well as companies in the forging, household equipment, packaging, energy and electrical industry.

Schuler is the market leader in minting presses and supplies systems solutions for the aerospace, railway and large pipe industries. Innovation is in our DNA: Schuler technology ensures maximum productivity, a high level of energy efficiency, and reliable processes in series manufacturing as well as in lightweight construction. We present this cutting-edge technology in our Tech Centers. With 5,400 employees, Schuler is represented in 40 nations around the world. The Austrian ANDRITZ Group holds a majority share in Schuler.

PARTNERS FOR FORGING TECHNOLOGY 92

SCHULER SERVICE 94

SCHULER ACADEMY

Success through expertise. The Schuler Academy offers various training sessions and seminars on forging as well as topics associated with all aspects of forming technology. At www.schulergroup.com/academy, you will find our full range of services offered. From there, you can also download the seminar catalog in PDF format.

LOCATIONS

PARTNERS FOR FORGING TECHNOLOGY



Schuler Group Headquarters, Göppingen.

forging@schulergroup.com
www.schulergroup.com/forging

Mechanical presses for hot forging

Schuler Pressen GmbH
Schussenstraße 11
88250 Weingarten | Germany
Phone +49 751 401-2214
Fax +49 751 401-2694
Schuler Service Phone +49 751 401-2244
Schuler Service Fax +49 751 401-2670

Mechanical presses for cold and warm forging

Schuler Pressen GmbH
Bahnhofstraße 41
73033 Göppingen | Germany
Phone +49 7161 66-307
Fax +49 7161 66-729
Schuler Service Phone +49 7161 66-628
Schuler Service Fax +49 7161 66-626

Hydraulic presses for cold and hot forging

Schuler Pressen GmbH
Louis-Schuler-Straße 1
68753 Waghäusel | Germany
Phone +49 7254 988-226
Fax +49 7254 988-490
Schuler Service Phone +49 7254 988-325
Schuler Service Fax +49 7254 988-361

Service center forging hammers

Schuler Pressen GmbH
Industriegebiet Bergisch-Born
Am Weidenbroich 1a
42897 Remscheid | Germany
Schuler Service Phone +49 2191 95199-20
Schuler Service Fax +49 2191 95199-81

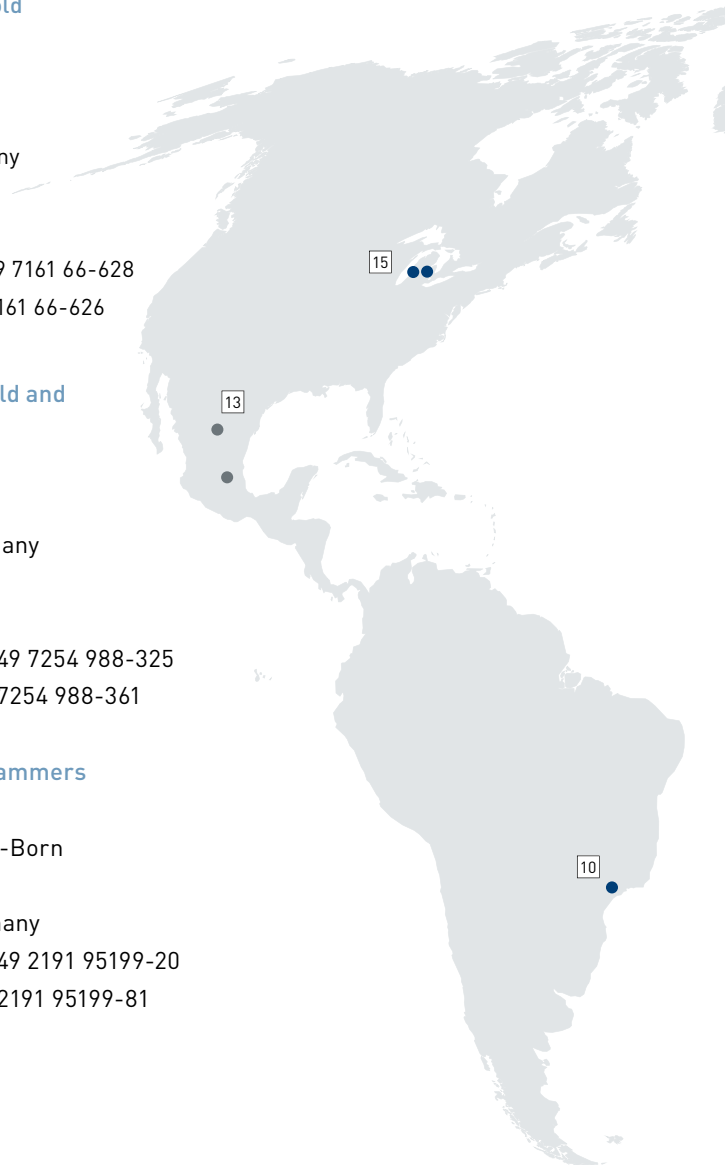

SCHULER ONLINE



With approximately 5,400 employees around the world at our own sites and in agencies, we are ready to serve you locally in 40 countries. We look forward to hearing from you. You can find an overview of our sites and contact information at www.schulergroup.com/plant_locations.

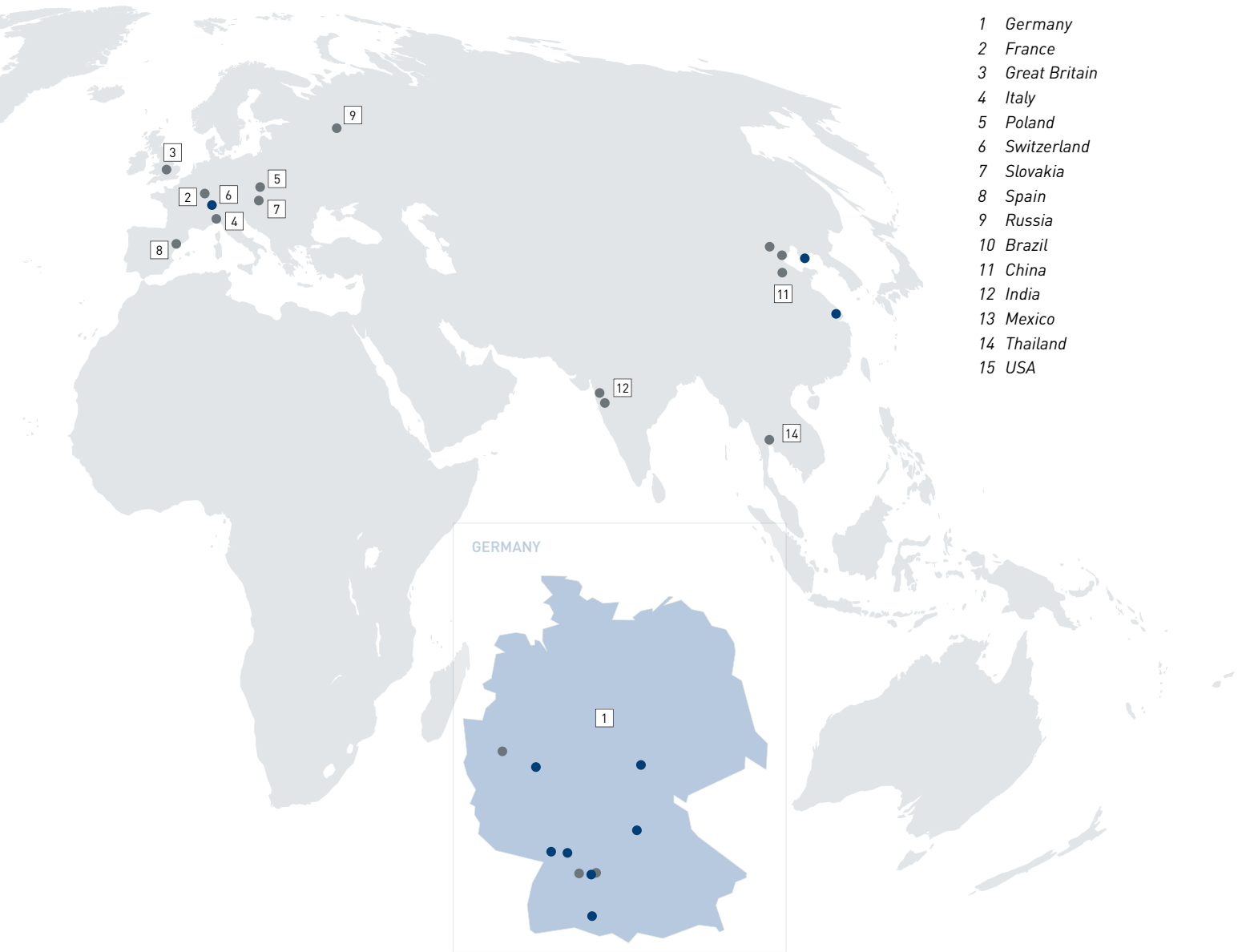

- 1 Germany
- 2 France
- 3 Great Britain
- 4 Italy
- 5 Poland
- 6 Switzerland
- 7 Slovakia
- 8 Spain
- 9 Russia
- 10 Brazil
- 11 China
- 12 India
- 13 Mexico
- 14 Thailand
- 15 USA

- Schuler production facilities
- Schuler Service

SCHULER SERVICE.

STATE-OF-THE-ART SERVICE FOR
MORE PERFORMANCE.

Schuler Service offers a tailored portfolio of services covering the entire life cycle of your equipment.



Schuler Service – Customer-oriented & efficient, worldwide.

Over 900 service employees worldwide provide expert support 24/7 in close cooperation with you – our partners. Our main priority is always to ensure the maximum productivity and safety of your production equipment in order to secure your company's continued success.

With over 175 years of experience and expertise, we can guarantee the best possible support for the operation of your machines – and not only those supplied by Schuler, but by all other manufacturers. Whatever the situation, Schuler Service has the right solution for your specific needs.

OUR SERVICES FOR YOU.

Technical Customer Support:

- Machine inspections
- Safety inspections
- Preventive maintenance
- Repair
- Repair welding
- Production support

Components and Accessories:

- Spare parts and spare part packages
- Maintenance kits
- Repair parts
- Replacement parts

Project Business:

- Modernization
- Retrofits
- Refurbishment
- Machine relocations

Special Services:

- Service contracts
- Hotline and remote service
- Training
- Tailored customer training
- Optimizing plant & processes
- Consulting

Used Machinery:

- Purchase and sale
- Evaluation

SCHULER SERVICE ONLINE



Want to know more about our full range of services?

Simply scan the QR code with the camera of your smartphone or tablet.

www.schulergroup.com/service_en



www.schulergroup.com/forging

Find out more. Simply scan the QR code using the camera of your smartphone or tablet.

Mechanical presses for cold and warm forging

Schuler Pressen GmbH
Bahnhofstraße 41
73033 Göppingen | Germany
Phone Sales +49 7161 66-307
Phone Service +49 7161 66-628
Fax +49 7161 66-729

Mechanical presses for hot forging

Schuler Pressen GmbH
Schussenstraße 11
88250 Weingarten | Germany
Phone Sales +49 751 401-2214
Phone Service +49 751 401-2244
Fax +49 751 401-2694

Hydraulic presses for cold and hot forging

Schuler Pressen GmbH
Louis-Schuler-Straße 1
68753 Waghäusel | Germany
Phone Sales +49 7254 988-226
Phone Service +49 7254 988-325
Fax +49 7254 988-490

Service center forging hammers

Schuler Pressen GmbH
Industriegebiet Bergisch-Born
Am Weidenbroich 1a
42897 Remscheid | Germany
Phone Service +49 2191 95199-20
Fax +49 2191 95199-81

forging@schulergroup.com
www.schulergroup.com/Forging