

# The EZ Guide 250 "How To Guide"



DRAFT

# The EZ Guide 250 "How To Guide"

---

## Contents

Title	Section/Page
<b>EZ Guide 250 Table of contents</b>	
1. User Mode.....	1 - 3
2. Firmware.....	2 - 3
2.1 Check the Firmware Version.....	2 - 3
2.2 Check memory stick compatibility.....	2 - 4
2.3 Downloading firmware.....	2 - 4
2.4 Unzipping firmware and placing firmware onto memory stick.....	2 - 5
2.5 Updating the Screen.....	2 - 5
3. Correctly configuring the 250 light bar settings.....	3 - 6
3.1 Satellites.....	3 - 6
3.2 SBAS Positions.....	3 - 6
3.3 On PathFilter.....	3 - 7
4. Installation of Equipment	
4.1 Correctly mounting the Antenna.....	4 - 8
4.2 Upgrading the Antenna.....	4 - 8
4.3 Mounting the Screen.....	4 - 9
5. EZ Guide 250 Add On Functions.....	5 - 10
5.1 Adding an EZ Steer CAN Connection.....	5 - 10
5.2 Adding a Coverage Switch.....	5 - 10
5.3 Adding a RADAR out Connection.....	5 - 11
5.4 Adding an 'NMEA OUT' or 'RTCM IN' Cable.....	5 - 11
6. Data Management	
6.1 Field Management.....	6 - 12
6.2 Deleting Coverage Logging.....	6 - 14
6.3 Summary Reports.....	6 - 15

# The EZ Guide 250 "How To Guide"

## 1. User Mode

**Please Note:** The EZ Guide 250 comes set on 'Easy Mode'. Please set the 'User Mode' is set to 'Advanced' so that the various settings shown in this How To Guide can be accessed.

- On the run/main screen press the down arrow until you have selected the  icon and then press OK. The '**Configuration**' screen appears shown in [Figure 1.1].
- Select '**User Mode**'. The '**User Mode**' screen appears shown in [Figure 1.2] and select Advanced by pressing OK.

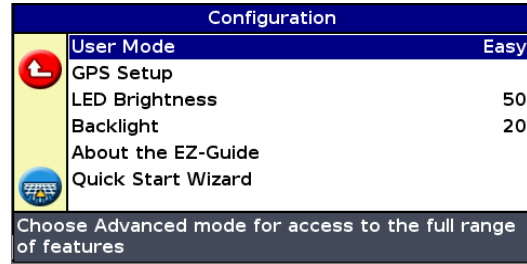

[Figure 1.1]

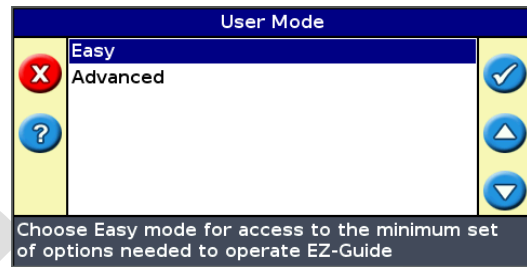

[Figure 1.2]

## 2. Firmware

**Please Note:** Firmware is the software that runs the EZ Guide screen.

### 2.1 Checking the Firmware Version

- Choose the Spanner  icon. The '**Configuration**' screen appears, as shown across in [Figure 2.1] press down to '**About the EZ-Guide**' and press OK.
- The '**About the EZ-Guide**' screen will appear as shown in [Figure 2.2]. The Firmware version is highlighted in red
- The current level of firmware is Version-3.10

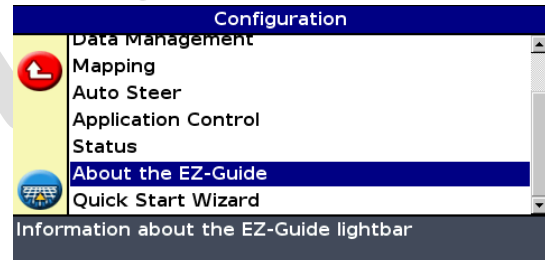

[Figure 2.1]

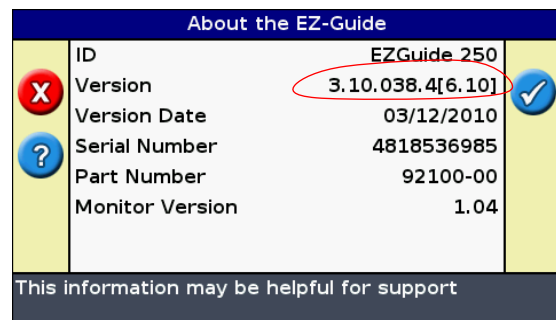

[Figure 2.2]



# The EZ Guide 250 "How To Guide"

## 2.2 Check memory stick compatibility

- Please note that not all memory sticks are compatible with the EZ-Guide 250. Some **(Not all)** FAT/FAT32 Memory sticks are compatible with the EZ-Guide 250.
- A green memory stick symbol will appear in the bottom left hand corner of the screen if the memory stick is compatible. This is shown in figure 2.3
- The colour of the memory stick icon will show the status of the memory stick as shown in Figure 2.4.
- Compatible memory sticks can be ordered through CNH Parts. **Part No 73321221**



[Figure 2.3]

ITEM	DESCRIPTION
	The USB drive is connected and ready
	The USB drive is connected, but currently loading
	The USB drive is disabled due to an error

[Figure 2.4]

## 2.3 Downloading firmware

- EZ-Guide 250 firmware can be found in two different locations.
- Assist Home Page
  - CNH Trimble Support Page

### 2.3.1 ASIST home page

- Once logged into assist, click on the '**EZ-guide & FM1000 Software update information**' link shown across in [Figure 2.5] and choose EZ Guide 250. This will open the link to save the file.

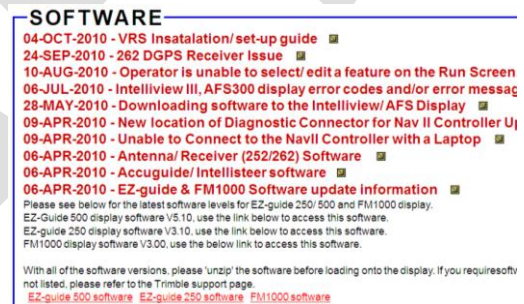

[Figure 2.5]

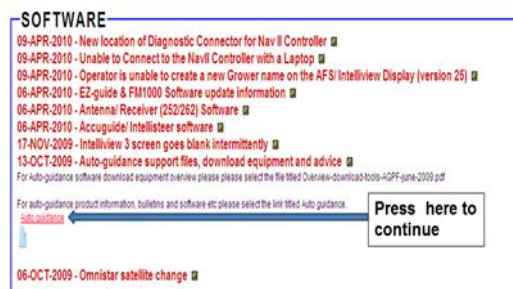

[Figure 2.6]

# The EZ Guide 250 "How To Guide"

## 2.3.2 CNH Trimble Support Page

- When logged into assist, choose '**Auto-guidance support files, download equipment and advice**' shown in [Figure 2.6]. Click on the '**Auto-guidance**' link.
- From the link that opens chose the '**Trimble AutoPilot and EZ Support files**'.

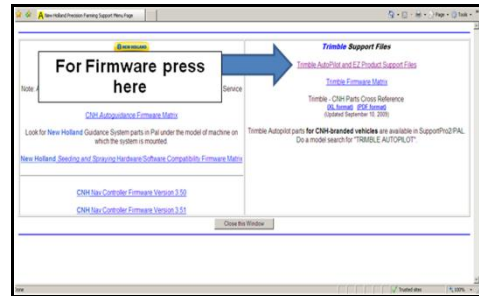

[Figure 2.7]

## 2.4 Unzipping firmware and preparing memory stick

- Once downloaded the ZIP file should then be copied to the root (first) folder of a compatible memory stick.
- The file must then be Unzipped before it can be used. This can be done by right clicking on the file and selecting '**extract here**' as shown in [Figure 2.8].

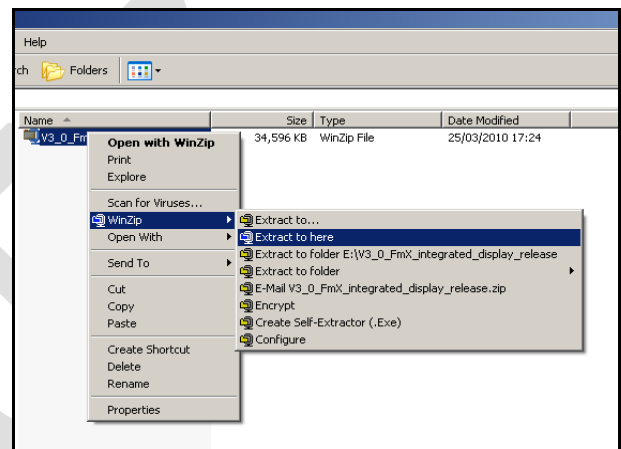

[Figure 2.8]

**Note: The computer programme WinZip is needed to Unzip the file before the memory stick can be inserted into the EZ-Guide 250.**

## 2.5 Updating the Screen

- Once the memory stick is inserted into the screen, the screen will recognise the newer firmware and the warning screen shown in [Figure 2.9] will appear.
- Pressing the OK button will go through the procedure of updating the screen this will only take a few minutes to do.



[Figure 2.9]

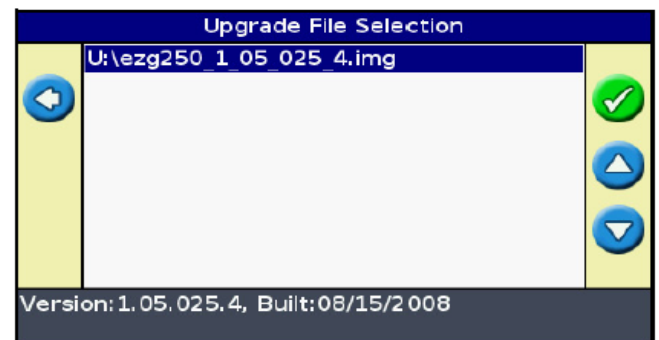

[Figure 2.10]

# The EZ Guide 250 "How To Guide"

## 3. Correctly Configuring the

### 3.1 Satellites

Note: It is important to have the latest firmware in the screen, it doesn't mean that the screen is using the optimum setting and satellite configurations.

- Select , *System, GPS, GPS Setup*'.
- Choose *'WAAS/EGNOS'* shown in [Figure 3.2]. In *'WAAS/EGNOS Settings'* scroll down to *'Satellite'* and press 'OK' as shown in [Figure 3.3].
- The optimum satellite used in the UK and Europe is *'EGNOS 120 AOR-E'*.
- If you have correctly configured the screen as shown and still have a poor signal from *'EGNOS 120 AOR-E'* then *'EGNOS 124 ARTEMIS'* can also be used.

### 3.2 SBAS Positions

Note: *'SBAS positions'* is a GPS quality indicator, This gives you the option of extending your operating hours by running the system when GPS satellites are less available and possibly providing lower position quality. Alternatively, you can select the best level of quality in order to achieve the maximum accuracy.

## 250 Light Bar settings

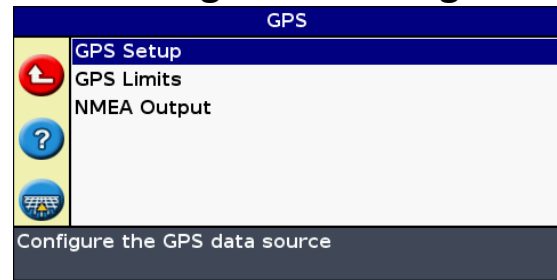

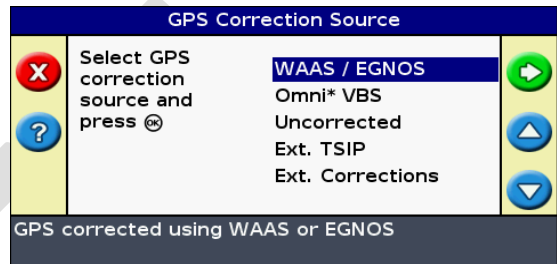

[Figure 3.1]

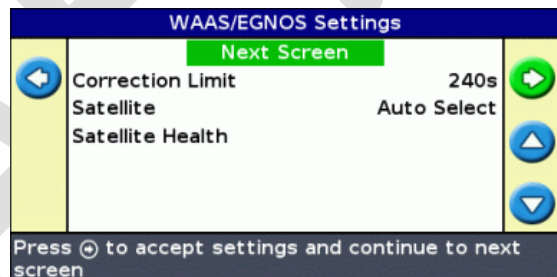

[Figure 3.2]



[Figure 3.3]

Bars	Option	Select ...
	Favor Accuracy	For operations that require the highest accuracy. <b>Note</b> – Trimble recommends this option for the best pass-to-pass accuracy. This option is equivalent to the quality level of previous versions of the EZ-Guide firmware.
	Balanced Quality	To trade potential accuracy for a slight increase in production time.
	Favor Availability	To extend production time further, with more potential for reduced accuracy.

[Figure 3.4]



# The EZ Guide 250 "How To Guide"

- The optimum setting for this will depend on what operation is being done in the field and the type of area that is being worked in. If high accuracy is needed then **'Favour accuracy'** should be chosen.
- If low accuracy is being used such as mapping fields then balanced quality should be chosen. If the signal is poor then **'Favour availability'** should be chosen.
- This setting can be changed by selecting the '🔧' icon and choosing 'SBAS Positions' as shown in [Figure 3.6]. The default 'SBAS Position' setting is **'Favour Accuracy'**, change this to 'Balanced Quality' when setting up the EZ Guide for Lightbar use.

### 3.3 On Path Filter

- The OnPath Filter should be set to match the area that the tractor is working in. Select **'Configuration (🔧), System, GPS, GPS Limits'** and then select OnPath Filter as shown in figure 3.7.
- There are 5 different settings as shown in figure 3.8. If the settings chosen does not match the area the screen is working in then the screen will tend to lose GPS signal quiet often.

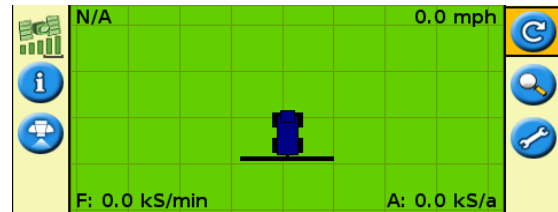

[Figure 3.5]

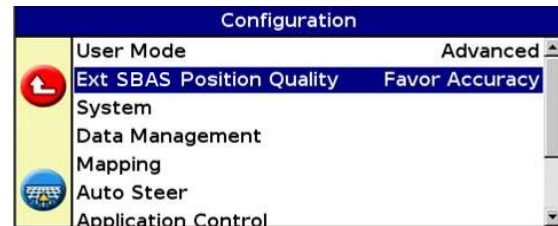

[Figure 3.6]

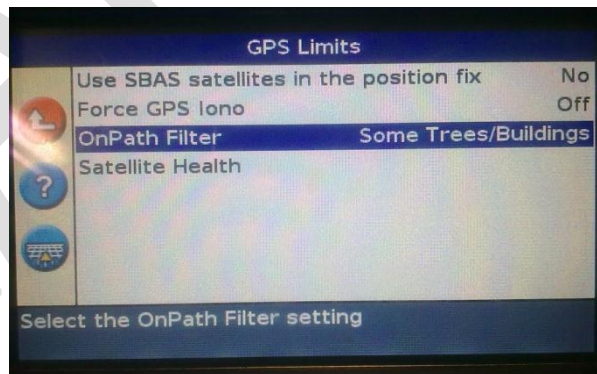

Figure 3.7

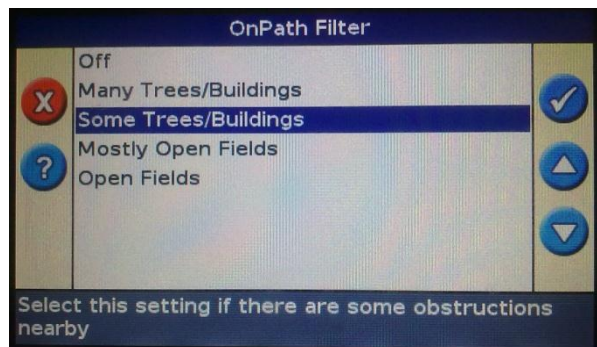

Figure 3.8

# The EZ Guide 250 "How To Guide"

## 4 - Installation of Equipment

### 4.1 Correctly mounting the Antenna

- The antenna should be mounted on the roof of the cab, in the centreline and as far forward as possible (without blocking the signal). The blue square shown in [Figure 4.1] displays where the antenna should be mounted. The antenna must be mounted as far forward as possible because once the tractor goes off line the further forward the antenna is the sooner the EZ Guide can correct the error.

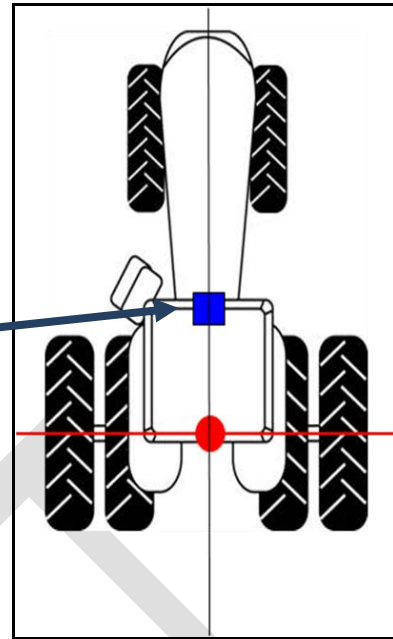

[Figure 4.1]

### 4.2 Upgrading the Antenna

- The EZ Guide 250 comes with a Patch Antenna as standard. This is accurate up to 70cm. In order to achieve an accuracy of 20 to 30cm then an Antenna upgrade is needed.
- The Part Number for the upgrade kit is 73321218. This includes the Ag15 antenna, mount plate and the antenna cable. The EZ Guide must be told which antenna is connected, Patch antenna is a 5Volt antenna where the Ag15 is a 10Volt antenna.



[Figure 4.2]

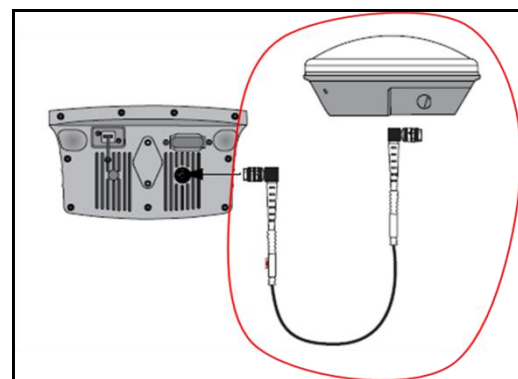

[Figure 4.3]

**Note: Going through the getting started wizard will allow the antenna type to be selected.**



# The EZ Guide 250 "How To Guide"

---

## 4.3 Mounting the screen

- The screen is mounted to the front windscreen using a suction cup. The part number for the suction cup is 87301269, removing the wing nut on the suction cup allows the circular Ram Mount that comes with the EZ Guide 259 kit to screw on the suction cup as shown in [Figure 4.4]. Mounting is shown in [Figure 4.5].



[Figure 4.4]



Figure 4.5

- If the EZ Guide 250 screen is being used with EZ Steer then the most convenient way of mounting the screen is to fix it to the bracket on the right hand door shown in Figure 4.6 and figure 4.7. This is an ideal location because the Lightbar is not needed on the windscreen when using EZ Steer, also the EZ Steer engage button is in a more convenient location.



Figure 4.6



Figure 4.7

# The EZ Guide 250 "How To Guide"

## 5 EZ Guide 250 Add On Functions

### 5.1 Adding an EZ Steer CAN connection

- The standard cable that comes with the EZ Guide 250 is shown in figure 5.4. To enable EZ Steer to be used with the screen, the EZ Steer add on cable must be purchased. The Part Number for this cable is **73321220**. The cable diagram shown in figure 5.4 shows the Pin connections to add EZ Steer to an EZ Guide 250.

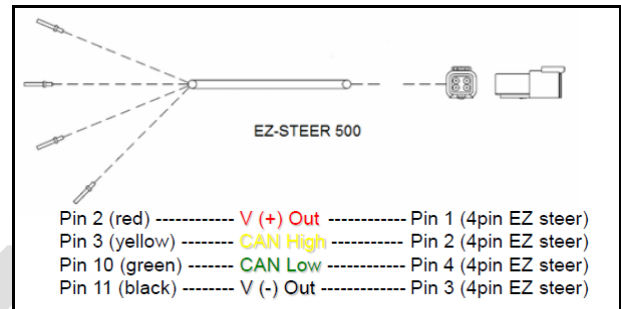

Figure 5.4

### 5.2 Adding a Coverage Switch

- To add a coverage switch to an EZ guide 250 then the relevant cables can be found by ordering the Part number **73321232**. The pin out for the cable received is shown in figure 5.5, also included is the cable that goes to the coverage switch. The external switch has to be sourced locally and is not available from CNH parts.
- To configure the coverage switch then choose '**Advanced Mode / System / Guidance / Coverage logging, select the Switch option**'. This is shown in figure 5.6. The switch can either be wired Active when the switch is Open (**Active Low**) or active when the switch is Closed, (**Active High**).

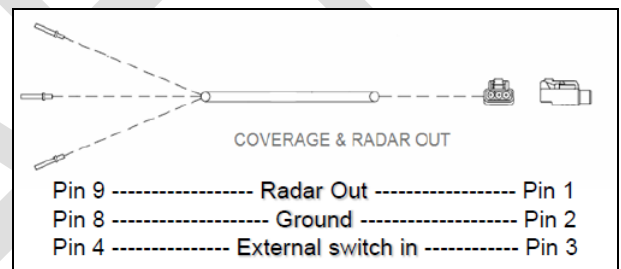

Figure 5.5

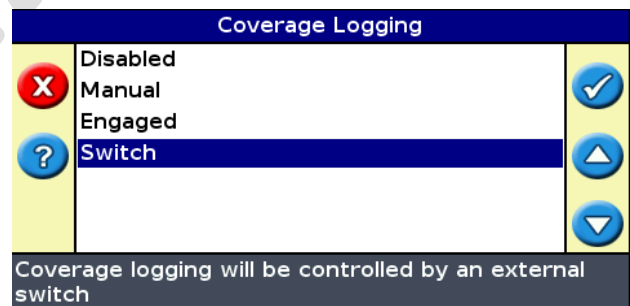

Figure 5.6

# The EZ Guide 250 "How To Guide"

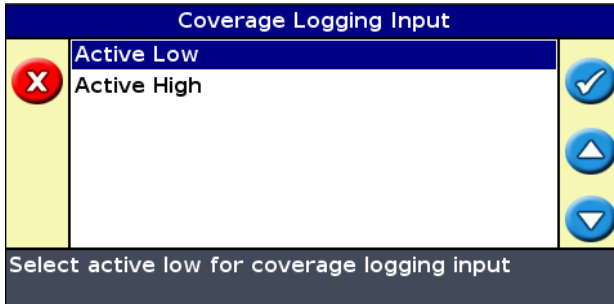

Figure 5.7

- To access the NMEA messages that are output, you require the all-port cable (P/N 64045) or the serial port add-on cable (P/N 63076). The cable needed to add NMEA Output or RTCM Input shown in figure 5.10 and P/N is 73321231

## 5.3 Adding a RADAR out Connection

- The cable that is needed for RADAR Output, P/N is **73321232** and this is same cable that is used for wiring a coverage switch, the various cables needed are shown in the table 5.9 across.

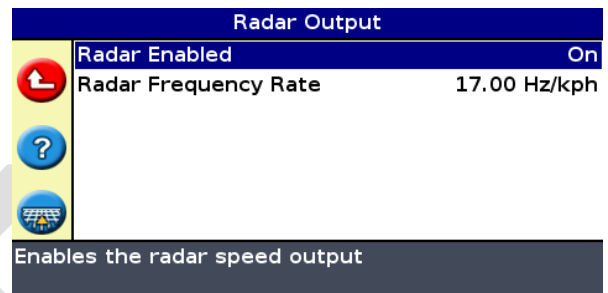

Figure 5.8

- Connect the relevant cables to the controller and choose 'configuration-system-radar output'. Select On for Radar Enabled and then choose the appropriate Radar frequency Rate for the controller. Raven and Midtech
- controllers use 58.94 Hz/mph (34.80 Hz/kph)

P/N for Radar Out Cables for EZ Guide 250
73321233 - Cable for Radar speed output for Raven Controller
73321234 - Cable for Radar speed output for Dickey-John Controller
73321235 - Cable for Radar speed output for Hiniker Controller

Table 5.9

## 5.4 Adding an 'NMEA OUT' or 'RTCM IN' Cable

**Note: 'NMEA out' is output from velocity, position, direction to 3rd party controllers (e.g. Vicon)**

**'RTCM In' is input of external GPS data (e.g. From a 262 receiver)**

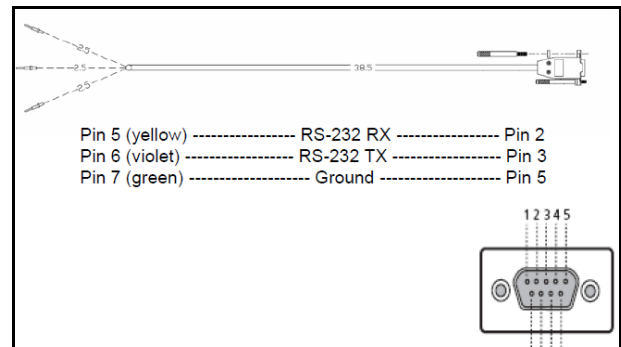

Figure 5.10

# The EZ Guide 250 "How To Guide"

- To configure NMEA output, select **'System/GPS/NMEA Output'** shown in [Figure 5.11].

**Note:** To be able to communicate, the parameters must match those of the device.

- Set the Lightbar port parameters. The baud rate and the output rate need to be the same between the EZ-Guide and the implement controller
- Select 'OK' Screen and then the **'Message Selection'** screen appears.
- Set the various message formats to On or Off, depending on whether they are required. Then select OK'
- Finally Configure the **'NMEA GGA output decimal places'**.

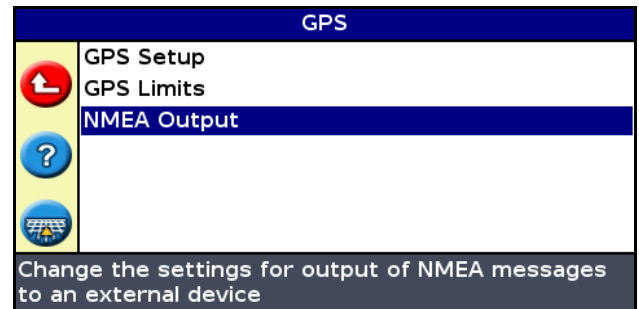

[Figure 5.11]

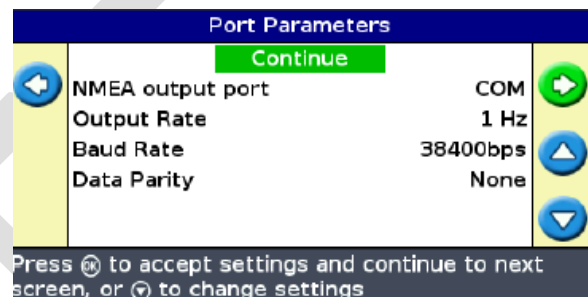

[Figure 5.12]

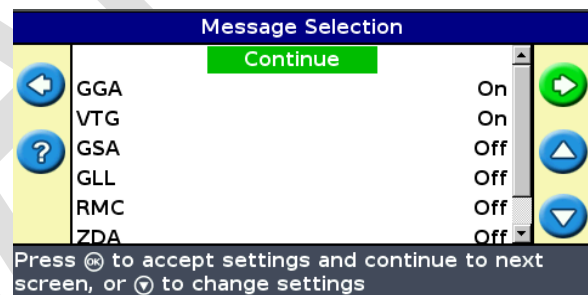

[Figure 5.13]

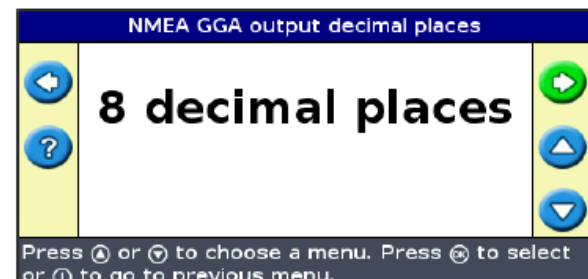

[Figure 5.14]

# The EZ Guide 250 "How To Guide"

## 6 Data Management

**NOTE:** To take data from the EZ Guide 250 a compatible memory stick is needed. Please refer to page 3 for the compatible memory sticks section.

### 6.1 Field Management

- The EZ Guide 250 can hold approximately 60 fields in its internal memory. Once the 60 fields have been used then the operator will have to transfer the field information or delete some of the fields to be able to continue. The Memory left can be seen in the information tab on the home screen as '**Storage**' (hours).

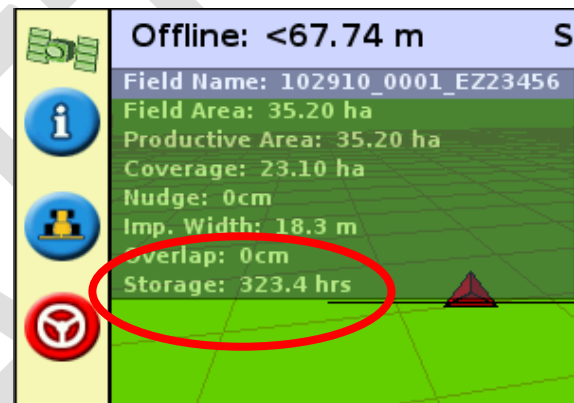

Figure 6.1

#### 6.1.1 Sending fields to a memory stick.

- While in Advanced mode going to '**Configuration, data management, Manage Fields**' and then select '**Send fields to Memory Stick**', choosing this option will send all the field data from the screen on to a memory stick.

#### 6.1.2 Deleting Fields

- Remove the memory stick and select '**Configuration, Data Management, Manage Fields, Delete Selected fields**'. It is then possible to choose what fields, what farms or what clients to delete.

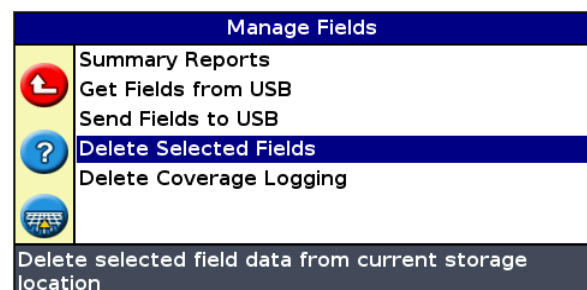

Figure 6.2

# The EZ Guide 250 "How To Guide"

- Deleting all the clients as shown in Figure will delete all the data from the screen. Deleting one client will delete just all the farms and fields for that client.

## 6.1.3 Selecting fields from Memory stick

- When all the field data is saved on the memory stick this can be brought back on to the screen by selecting 'Get fields from USB'. It is now possible to select the required field from the USB Stick. The field is now copied on to the Screen once again.

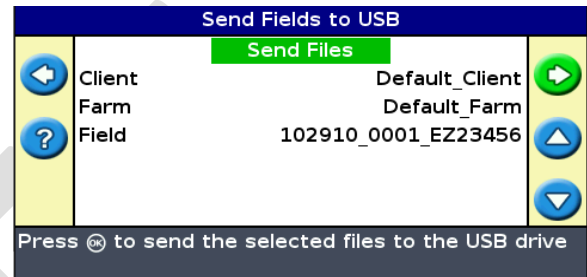

Figure 6.3

**NOTE: This is useful when transferring fields from one EZ Guide to another.**

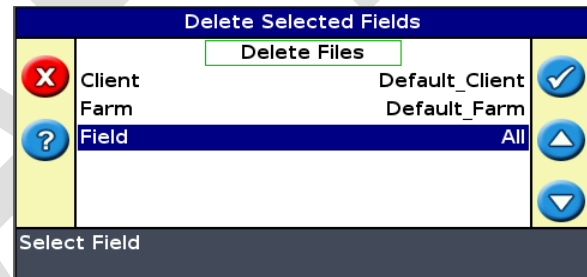

Figure 6.4

## 6.2 Deleting Coverage Logging

- Deleting field coverage logging is required when the operator wants to work in the same field that he had created before. Coverage logging is deleted, boundaries and obstacles remain this allows him to drive the same headland and AB lines without having to drive the boundary and create new AB Lines. To do this go to 'Configuration, Data Management, Manage Fields, Delete Coverage Logging'. This will allow the user to select the field he wants to delete the coverage logging.

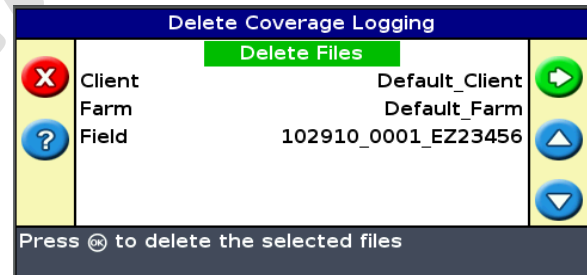

Figure 6.5



# The EZ Guide 250 "How To Guide"

## 6.3 Summary Reports

- To view field summary reports, insert a USB Stick and go to '**Configuration, Data Management, Summary Reports, Send Summary Reports to USB**'. This will then allow you to choose the field that you want to view the summary report or send all the summary report to the USB Stick.

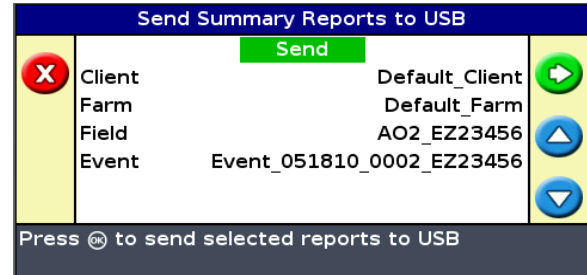

Figure 6.6

- Plug the USB Stick in to the computer, go to "**My Computer, USB Disk, AgGPS, Data, (Choose Relevant Client), (Choose Relevant Farm), (Choose Relevant Field), (Choose Relevant Event)**" and open up the Word document called "**EventSummary.rtf**". In this word document there are 6 pages. The information on them is as follows

1. **Event Details**
2. **Map of Overlap**
3. **Map of Height**
4. **Map of Applied Rate**
5. **Map of Speed**
6. **Mapped Features**

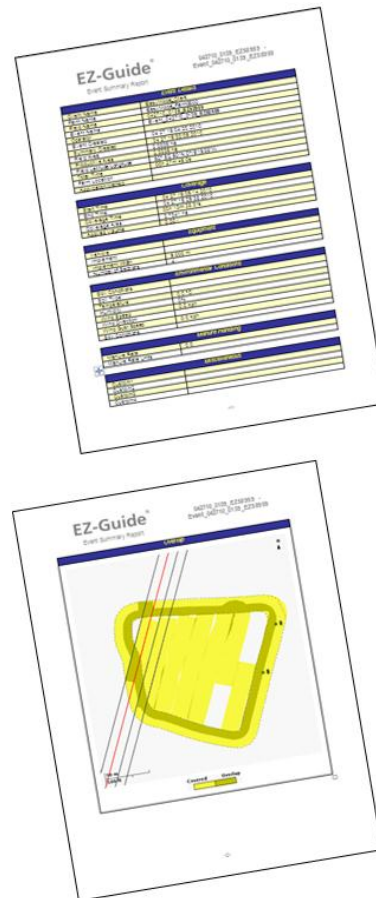

Figure 6.7

- Field area, Productive Area, and Total Times are all included in the report along with other information. Figure 6.7 Shows an example of the report.