

# 6

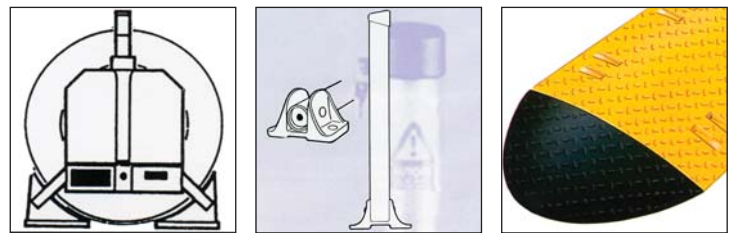

<b>Section 1</b>
Traffic Management Temporary Signage Roadworks Equipment
<b>Section 2</b>
Highway Maintenance Products
<b>Section 3</b>
Pedestrian Guardrailing Crash Barriers & Fencing
<b>Section 4</b>
Decorative & Amenity Bollards
<b>Section 5</b>
Amenity & Street Furniture
<b>Section 6</b>
Car Parks & Access Control

Collapsible Bollards	2-4
Anti Ram-Raid Bollards	5
Telescopic Bollards	6-7
Mild Steel Bollards	8
Boundary Bollards	9
Removable Bollards	10-11
Gates & Barriers	12-15
Amenity Lighting Bollards	16
Traffic Lights	17
Access Control	18-21
Cones, Cylinders & Lamps	22
Temporary Barriers	23
Traffic Separators	24
Salt & Grit Bins	25
Cycle/Perimeter Barriers	26-27
Portable Guardrailing	28
Column Protection	29
Rubber Barrier Protection	30
Flexible Bollards	31
Car Park Crash Barriers	32-35
Traffic Flow Plates	36-37
Speed Ramps	38
Road Markings, Road & Bay Marking Studs	39
Industrial & Traffic Mirrors	40-41
Wheel Clamps	42-43

## ► Collapsible Bollards



### ◀ Key operated standfast post (ex stock)

This highly successful post is ideal for reserving individual car parking spaces. It can be used as a visual deterrent to restrict access into driveways. Can be locked in the down or upright position. The floor mounted base is secured to a prepared concrete foundation by 3 No. M12 anchor bolts.

In the case of multiple orders, locks can be supplied with the same keys or with keys to differ. Anchor bolts as well as build in base option can be supplied at an extra cost.

**Specification:**

63.5mm dia x 620mm o/height mild steel. Base cast aluminium.

**Finish:** Yellow powder coated for high visibility. Other colours available on request.

**Ground clearance:** 102mm

**Weight:** 6kg

**Alternatives:** Galvanised finish. Rigid version available.

### ► Padlock standfast collapsible post (ex stock)

A low cost popular post designed to restrict access to car parking spaces, driveways, etc. Floor mounted base is secured by the use of 3 No. M12 anchor bolts to a prepared concrete foundation. It is lockable in the upright position by means of a padlock, which can be supplied with keys the same or to differ. Padlock, anchor bolts and alternative build in base can be supplied at extra cost.

**Specification:**

63.5mm dia x 768mm o/height

**Finish:** Hot dipped galvanised

**Ground clearance:** 102mm

**Weight:** 7kg

**Alternatives:** Powder coated only. Rigid version available



### ◀ Triangular padlock parking barrier

A space reservation barrier designed to fold completely flat when not in use. Vehicles can drive over it without damage to vehicle or post. The barrier can be locked in the upright or down position. Secured by a padlock supplied with 2 No. keys to pass or differ. This device is easily floor mounted by 3 No. M12 anchor bolts (supplied).

**Specification:**

Fabricated from 5mm thick mild steel.

650mm erected height, 58mm a/ground fully collapsed, 762mm o/length, 115mm o/width.

**Finish:** Red powder coated with white banding

**Ground clearance:** 58mm

**Weight:** 12kg



### ► Hinged lockable parking post (ex-stock)

Designed for the reservation of individual car park bays. When erected the post prevents unauthorised access and provides control without the need for supervision. Only the authorised user's key will release the locking mechanism, allowing the post to be lowered and thus enabling the vehicle to pass over it. In some situations it is possible to site the post so that it can be re-erected when the space is occupied, thereby acting as an added vehicle theft deterrent.

The hinged lockable post features an integral cylinder lock and a totally enclosed locking mechanism. To erect, simply raise the post to the vertical position and apply a moderate downward pressure to the top of the post. This will secure the post within the base plate recess. The key is not required to lock the post. To lower, release the locking mechanism with the key and lower the post. The post is lockable in the up and the down position.



### Type B hinged lockable post

Available for emergency service access. Usually specified by local authorities or fire brigades, this post is similar to the hinged lockable post (above) but includes an extended hinge pin (called a type B adaptor) to allow a fire brigade padlock to be fitted at the bottom of the post.

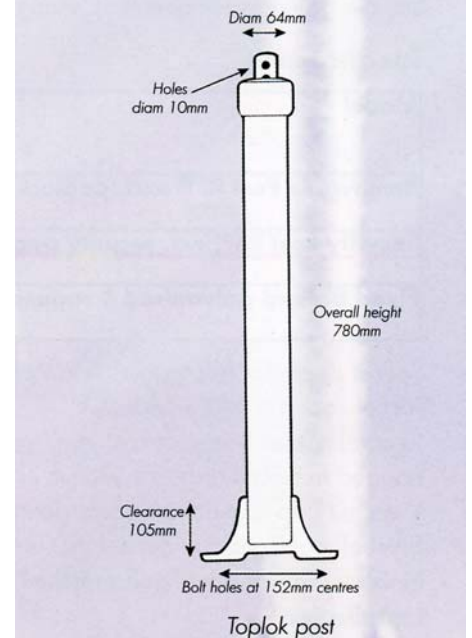
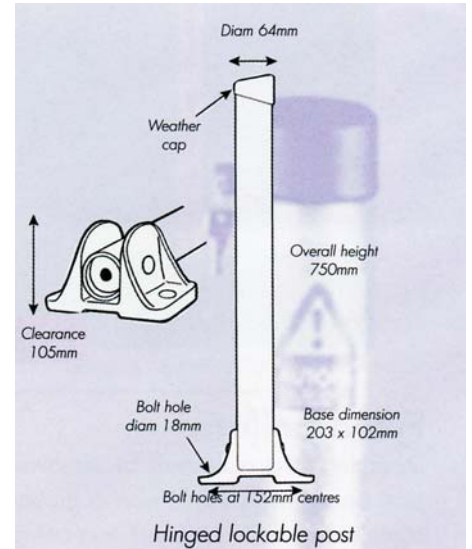

### ▲ Hinged Toplok parking post

Similar in design and use to the hinged lockable post. The Toplok post does not have an integral cylinder lock or spring assistance, but requires a padlock to be located on the locking rod which protrudes through the weather cap. The locking rod features two holes; the lower hole is for locating a padlock when the post is in the vertical position and thereby locking the post upright. The upper hole is for safety and conveniently retaining the padlock when the post is in the lowered position.

### ► Stealth post

For reserving individual parking bays as well as controlling common access points for smaller car parks and low use access areas. The stealth post also offers a deterrent to car theft when locked upright, and extra security for car parks in general. Fitting flush with the ground when down, the posts provide no obstruction to vehicles or pedestrians. The hinged lid lowers down to safely cover the excavated hole when in both the up and down positions. **Not suitable for heavily used areas nor for HGV use.**



## ► Collapsible Bollards (continued)



### ◀ Heavyweight key operated post

A larger and stronger version of the key operated standfast post, fulfills the role where a more substantial post is required. The base is pre-drilled to accept 4 No. M12 anchor bolts. The locks can be supplied with keys the same or to differ. Anchor bolts and alternative build in base can be supplied at an extra cost.

**Specification:**

89mm dia x 762mm o/height. Mild steel post and base.

**Finish:** Red powder coated with a white band (other colours available on request).

**Ground clearance:** 110mm

**Weight:** 10kg

**Alternative:** Rigid version available



### ► Heavyweight folding lockable post

This heavy duty post is intended for those applications where a standard car parking post is insufficient. For use mainly where heavy vehicles are involved. The floor mounted post is lockable in both the down and upright positions by means of a padlock. Standard post is floor mounted.

Alternative build in base, padlock and anchor bolts available at an extra cost.

**Specification:**

115mm dia x 994mm o/height

**Finish:** Black and white finish (galvanised base)

**Ground clearance:** 150mm

**Weight:** 23kg

**Alternative:** Rigid version available





## Telescopic anti ram-raid post

This extremely strong post is very effective in protecting warehouses, shops, stores and property against ram-raiders. It has been approved by both Police and local government authorities and recommended by insurance companies.

The unit is secured by a padlock situated inside the flanges to make it difficult for access. Raising and lowering can be achieved by using a T-key. The post can be removed and replaced when damaged or in need of servicing, reducing the time needed to excavate.

### Specification:

**Section of body:** 127mm x 76mm R.S. joist

**Height above ground:** 720mm (open)

**Length of unit o/a:** 950mm (closed)

**Finish:** Hot dipped galvanised

**Weight:** 40Kgs

**Alternative:** Rigid version available

Padlock can be supplied at an extra cost.

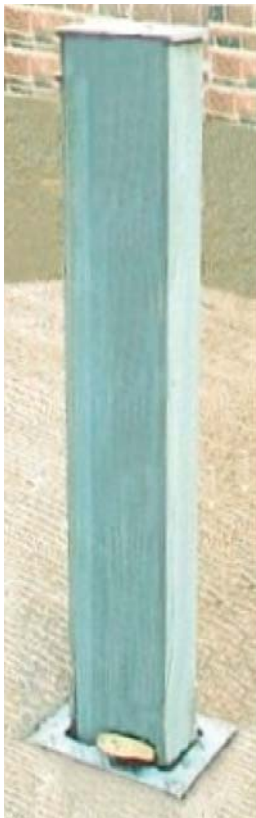

## Fixed anti ram bollards

We have introduced an anti ram-raid option to our selection of fixed bollards. The RSJ can be welded to the inside of any 114mm and 168mm diameter fixed bollard to make it ram-raid resistant.



## ► Telescopic Bollards

### ► Telescopic Mole post

The mole post is a low cost solution for providing effective security for a variety of applications, garage forecourts, drives and car parks. It can also be used for site demarcation i.e. cordoning off areas. The post is designed to retract into the ground when not in use; it is manually raised into its protecting position and secured by means of a padlock at the base.

**Specification:**

**Section of body:** 100mm x 100mm steel tube

**Height above ground:** 610mm (open)

**Length of unit o/a:** 785mm (closed)

**Finish:** Hot dipped galvanised

**Weight:** 25Kgs

**Alternative:** Rigid version available

Padlock can be supplied at an extra cost.

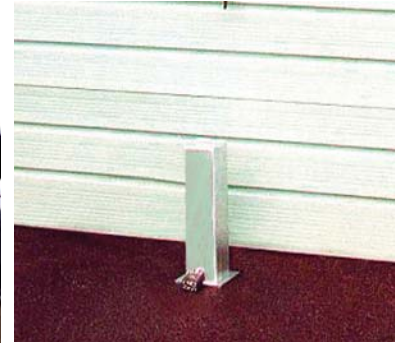
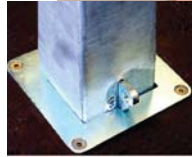

### ▲ Baby Mole post

As the name implies this is a smaller version of the mole post and is a very cost-effective way of protecting garage doors and gates, etc.

**Specification:**

**Section of body:** 100mm x 100mm steel tube

**Height above ground:** 310mm (open)

**Length of unit o/a:** 470mm (closed)

**Finish:** Hot dipped galvanised

**Weight:** 12Kgs

**Alternative:** Rigid version available

Padlock can be supplied at extra cost.

### ► Telescopic parking post

This post is an alternative to the telescopic mole post, with the padlock (not supplied) being situated at the top of the post, not at the base, for ease of operation.

Padlock can be supplied at an extra cost.



### ◀ Lockable telescopic parking post

This is similar to both the Mole and telescopic parking post but is superior in so much that it incorporates an integral pushlock and can only be lowered or raised using a T-key. The central stem can be removed and replaced if damaged or in need of servicing. When the post is in the lowered position it is protected by an 8mm thick steel hinged plate strong enough to enable vehicles to pass over without damage.

**Specification:**

**Section of body:** 100mm x 100mm steel tube

**Height above ground:** 610mm (open)

**Length of unit o/a:** 795mm (closed)

**Finish:** Hot dipped galvanised

**Weight:** 30Kgs

**Alternative:** Rigid version available

Supplied with 2 No. keys (further keys can be supplied at an extra cost). Locks can be keyed alike or to differ.

### ► Telescopic traffic stopper

This is a larger version of the telescopic parking post and is therefore much stronger to fulfil a role where a substantial post is required to deter ram raiders, etc.

**Specification:**

**Section of body:** 120mm x 120mm steel tube

**Height above ground:** 660mm (open)

**Length of unit o/a:** 914mm (closed)

**Finish:** Hot dipped galvanised

**Weight:** 40Kgs

**Alternative:** Rigid version available

Padlock can be supplied at an extra cost.



### ▲ Round telescopic post

A more aesthetically pleasing alternative to the telescopic parking post, but circular rather than square. Can be used around garage forecourts and car parks in various colours to suit the surroundings. The post can be removed and replaced when damaged or in need of servicing.

**Specification:**

**Section of body:** 101.6mm dia steel tube

**Height above ground:** 610mm (open)

**Length of unit o/a:** 795mm (closed)

**Finish:** Outer body hot dip galvanised, post sprayed nylon.

**Weight:** 28Kgs

**Alternative:** Rigid version available

Padlock can be supplied at extra cost.



### SF-RT/R14

Steel lifting handle

10 pin 'anti drill' push button lock

114mm round section x 5mm gauge mild steel

6mm mild steel lid

25mm x 10mm square bar reinforcement

140mm square section x 5mm gauge mild steel

6mm gauge base plate with drainage holes

850

1140

140<sup>2</sup>

1110

Mild steel to BS1449.  
Galvanised to BSENISO 1461 (1999)

◀ **MATCHING STATIC POST RB114**



### SF-RT/R14/HD

Steel lifting handle

10 pin 'anti drill' push button lock

114mm round section x 5mm gauge mild steel

101 x 4mm gauge sliding post sleeve

6mm mild steel lid

25mm x 10mm square bar reinforcement

140mm square section x 5mm gauge mild steel

6mm gauge base plate with drainage holes

850

1140

140<sup>2</sup>

1110

Mild steel to BS1449.  
Galvanised to BSENISO 1461 (1999)

◀ **MATCHING STATIC POST RB114AR**



### SF-RT/R5

Steel lifting handle

10 pin 'anti drill' push button lock

90mm round section x 5mm gauge mild steel

6mm gauge mild steel lid

25mm x 10mm square bar reinforcement

120mm square section 5mm gauge mild steel

6mm gauge base plate with drainage holes

670

900

950

120<sup>2</sup>

Mild steel to BS1449.  
Galvanised to BSENISO 1461 (1999)

◀ **MATCHING STATIC POST RSPR8**



### SF-RT/RD4

Steel lifting handle

10 pin 'anti drill' push button lock

76mm round section x 4mm gauge mild steel

6mm gauge mild steel lid

25mm x 10mm square bar reinforcement

100mm square section 4mm gauge mild steel

6mm gauge base plate with drainage holes

500

760

700

Mild steel to BS1449.  
Galvanised to BSENISO 1461 (1999)

◀ **MATCHING STATIC POST RS/D4**

All measurements in mm

## ► Mild Steel Bollards



Newtown bollard



Plain galvanised flat top 1500 x 140mm



L to R: 76mm, 101mm, 127mm and 152mm plain steel galvanised



Bollards painted to order

### ▲ ▼ Range of mild steel bollards

Available in round tube or square section. Adding security to your area as the bollards are exceptionally strong and will not fracture on impact. Ideal for ram-raid deterrence, protected parking and pedestrian walkways.

Steel bollards can be manufactured in a wide range of sizes and lengths - plain, stepped or with rings and castings. They are produced in galvanised form as standard but can be supplied painted or powder coated to most BS or RAL colours.

We carry some sizes in stock for quick delivery. For extra strength steel bollards can be filled with concrete on site.

### ► ▼ Range of polyurethane bollards

Street Furnishings supply a range of polyurethane bollards, all with a polymer casting over an internal steel core. These combined materials and construction give the bollards inherent structural strength, but also will not shatter on impact. Minimum maintenance is required as the bollards will not rust as they are made from a self-coloured flame retardant engineering grade polymer.

Many designs are available to order in most BS or RAL colours. Gold banding and reflective finishes can be supplied to your requirements.

#### ► Streetwise bollard

“The bollard that takes care of itself”.

This bollard has a smooth basic design which, once installed, requires zero maintenance. Highly resistant to accidental and deliberate damage.

#### Dimensions:

Typical height: 1000mm  
Typical root depth: 300mm  
Typical diameter: 150mm

Available in standard black and a range of popular colours.







## ◀ Sprung boundary post

The sprung boundary posts are similar to the standard fixed boundary post but incorporate a heavy duty spring towards the bottom of the post thus enabling it to withstand light to medium impacts from vehicles. Used for marking boundaries of parking spaces, siting between hinged posts and for protection of walls and buildings. After impact the spring allows the post to return to the near vertical position - minimising damage to the post and to the vehicle.

The sprung boundary post can spring to approximately 30° from the vertical position.

### Specification:

- Made of mild steel tube 48mm o.d. 750mm above ground. Ragged version 240mm below ground
- Flanged version requires 3 No. 12mm bolts. Circular flange of mild steel, diameter 134mm, 6mm thick
- Weather cap of black polypropylene
- Galvanising is standard finish. Colour coated options available at extra cost

### Installation:

- Flanged posts should be bolted to a suitable existing surface, preferably concrete
- Ragged posts should be cast in a concrete foundation approx 300mm cube. The ragged ends ensure a good anchorage into concrete

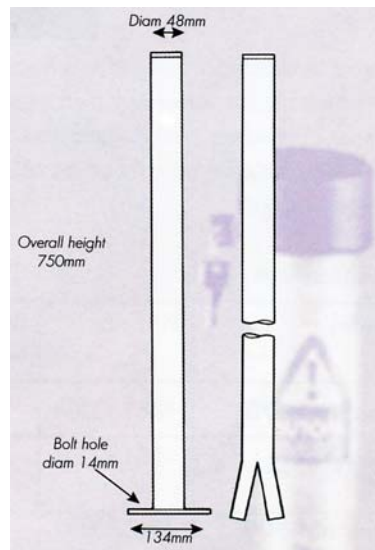

## ▼ Boundary post

Boundary posts are fixed posts with either ragged ends for casting in or flanged ends for bolting down. They can be positioned between hinged posts to prevent unauthorised parking, or used as a permanent post by themselves to mark lateral limits, or with chain and eyelets to block access points.



## ▶ ▼ Rubber bollard

The flexible bollard which can bend down to 90° without normally being damaged, it will in time return to its original position. Low speed impacts will cause virtually no damage to the bollard, therefore considerable replacement costs are avoided.

Extremely robust, durable and maintenance free, the Universal and Konus are made from recycled granulated rubber. The bollards are flexible with no sharp edges, making them safe for pedestrians, cyclists and drivers. 200kg force needed to bend to 45°.



## ▲ Universal rubber bollard

### Installation:

Excavate hole 780mm deep, 300mm diameter, insert steel tube, pack sand to required depth then place bollard in hole and pack sand around to secure it.



## ▲ Konus rubber bollard

### Installation:

Simply drill and bolt down on to a suitable concrete surface. 6x12mm bolts available at extra cost.

Model	Finish	Height above ground (mm)	Below ground depth (mm)	Diameter at base (mm)	Extra info
Universal	Black	1000	340	140	Steel socket 780mm long x 160mm od, Weight 25kg
Konus	Black	740	n/a	140	Flange height 50mm x 305mm diameter Weight 16kg + 1.5kg for flange

## ► Removable Bollards

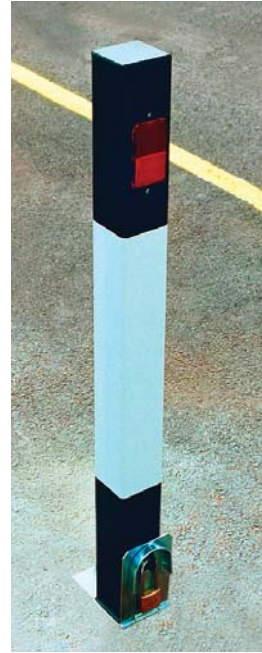

### ▲ ► Heavyweight removable bollards (ex-stock)

This range of bollards will meet all requirements to prevent unauthorised entry of vehicles and restrict access. The bollard is a heavy duty post that locates into a socket embedded into concrete. The post is locked in position by use of the socket flap and a padlock (supplied at extra cost). When the post is removed, the socket flap can be padlocked in the closed position keeping the socket free from rubbish until the post is next used. The removable bollard is available in three sizes:

**Small:** For use in driveways, forecourts, etc.

**Intermediate:** Car park use, town centres, supermarkets, garages.

**Large:** For heavy duty applications where lorries, vans, etc. are involved.

Handles are supplied on the large bollard only to assist removal of the post. All three sizes have amber reflectors on both sides.

**Standard colour:** Black and white (other colours available).

We are also able to supply rigid posts in addition to these removable posts. These are available in either floor mounted or build in type versions. Chain lugs are not standard but can be supplied upon request.

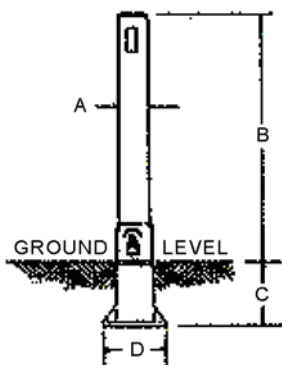

Ref	Small	Inter- mediate	Large
A	70 x 70	80 x 80	100 x 100
B	690	965	1100
C	200	250	300
D	140	140	200
Weight	7kg	13kg	22kg

Measurements in mm





### ◀ ▶ Removable post RPP

Forms a rigid barrier when positioned. It is used to exclude the access of all but emergency and service vehicles from traffic-free zones and to prevent unauthorised access. Commonly found where access is only occasionally required, or required during daytime so posts can be locked in at night. To remove the post, the padlock (available extra) is unlocked, the pin is disengaged from the locking bracket on the underside of the ground plate and the post can be lifted out. Once clear, the flap closes flush with the ground leaving no projections or unprotected holes. Retaining pin and hinge pin of zinc plated mild steel.



### ◀ Security post type RSP removable security post

Similar to the standard removable post RPP, but supplied complete with a high security sliding bolt padlock and two keys and a hardened steel retaining pin. Ideal for providing a high security vehicle obstruction for car forecourts, driveways, perimeter and access points, thereby providing a physical, secure barrier to car theft. When the post is removed, the socket flap closes flush with the surrounding ground level.

### ▶ Removable wooden bollard

- Common size 1500 x 150 x 150mm
- 4-way weather top
- With or without reflectors



### ▼ Road warning signs

Street Furnishings can provide road warning signs to be used in conjunction with our vehicle access control equipment. It is recommended that signage is used to warn of speed, height or entry restrictions.

#### Specification:

300mm signs can be used for private roads and signs 600mm upwards are available for public highways. Signs are constructed from (11 gauge, 3mm thick) aluminium as standard.

Lightweight foamex signs are also available.

3m, 3.5m, 4m and 5m by 76mm diameter galvanised steel posts can also be provided along with relevant fixings.



A small sample from our vast range of available signs



Cycle parking sign, used with the cycle stand



Speed ramp sign on galvanised steel post

# ► Gates & Barriers



## ▲ ► Swinging gate

The swinging gate is of mild steel tubular construction throughout and is based upon a rigid triangular form, complete with strengthening struts and a central plate to accommodate a sign (available at extra cost). The gate swings on a tubular sleeve, mounted on brass bushes for ease of movement. Maximum width available is six metres. If opening is larger, we strongly recommend the use of two gates locked centrally by use of a removable latch post.



Finish: white (other colours available on request).

Recommended height of top beam above ground 1000mm. Gates are supplied with 1 No. latch post. A further latch post can be supplied (at extra cost) for locking gate in the open position. The gates can be locked by padlock or, at an extra cost, by an integral push lock.

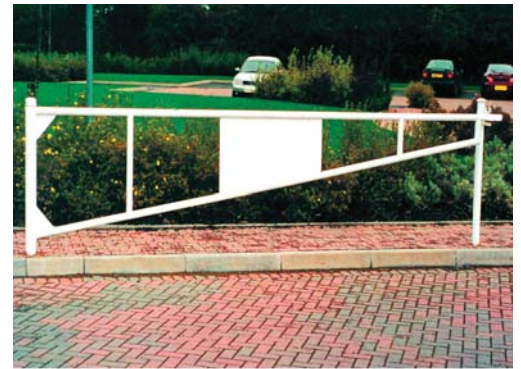
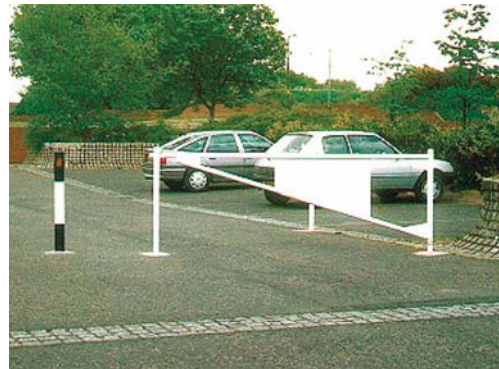

## ▼ Single or double swing gate

### Specification:

- Galvanised steel construction painted red with white/red class 2 reflectors
- Main pivot post 120 x 120 x 5mm steel, 966mm to underside of boom
- Boom length up to 6.0m
- Boom of 60 x 60 x 3mm steel
- Lockable by padlock (available extra)
- Main post - 4qty 16mm bolts required to bolt down
- End catch post 4qty 12mm bolts needed

- Catch post of 90 x 50 x 3mm steel
- Catch post adjustable to  $\pm 70$ mm
- Additional catch post is required to lock gate in open position

### Installation:

- Main foundation 600 x 600 x 500mm deep minimum
- Catch post foundation 300mm cube
- Also available with ragged end for casting into ground

Available as 3m, 4m, 5m, 6m (inside measurement flange to flange = given length minus 200mm)

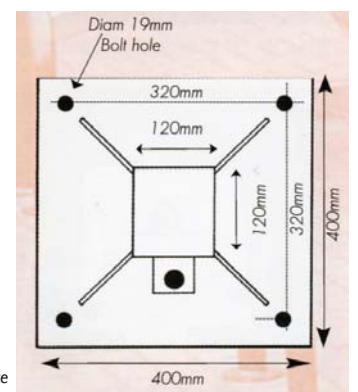

Base plate for swing gate

## ► Manual arm barrier

### Specification:

- Steel pivot post 120 x 120 x 5mm mild steel
- End catch post 50 x 50 x 4mm mild steel
- Finish - galvanised and painted red
- Height 1.0m to underside of boom
- Boom - up to 7.0m length made of rectangular aluminium section, 76mm x 38mm, 3.2mm thick, finished in white with red class 2 reflective tape
- Boom weight 2.0kg/m

### Installation:

- Recommended concrete foundation 600 x 600 x 500mm deep minimum for main post
- Catch post foundation 300mm cube
- Also available with ragged end for casting into ground
- Requires 4 qty 16mm bolts for main pivot post. Main base size 400 x 400 x 10mm steel
- 4 qty 12mm bolts required for catch post
- Catch post adjustable to  $\pm 70$ mm
- Lockable in raised and lowered position by padlock (available extra) Padlock can fit at either end
- Skirt option available, for up to 6m size only

Available as 3m, 4m, 5m, 6m, 7m (measurements from flange front to end of boom).

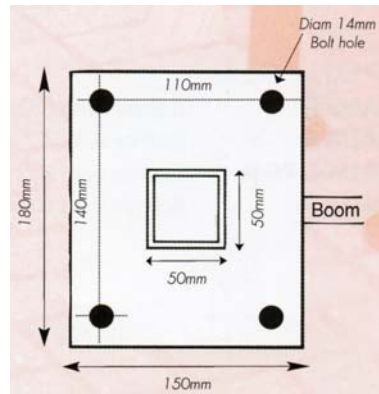

Base plate for end catch post for manual arm barrier and swing gate

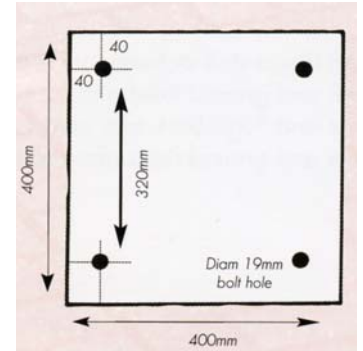

Base plate for manual arm barrier



High restrictor

## ◀ Height restrictor (fixed or swing)

### Specification:

- Galvanised steel main post construction 90 x 90 x 3mm (fixed). Base 400 x 400 x 10mm thick. 120 x 120 x 5mm for swing version main post
- Swing boom catch post 90 x 50 x 3.6mm thick. Base 340 x 254 x 10mm thick
- 2.05m  $\pm 70$ mm standard clearance to knocking arm
- All fabrication of galvanised steel construction
- Finish painted red with white class 2 reflective tape
- 4 qty 16mm bolts required for each leg
- Swing boom lockable by padlock (available extra)
- Swing boom version with additional catch post available for occasional access by high sided vehicles. Additional catch post will be required if swing boom is to be locked in the open position
- Up to 6m post centres
- Also available with ragged end for casting into ground
- Road warning signs are available

Available as 3m, 4m, 5m, 6m (both fixed and swing versions)

### Installation:

Main foundations 600 x 600 x 500mm deep minimum. Catch post foundations 300mm cube.

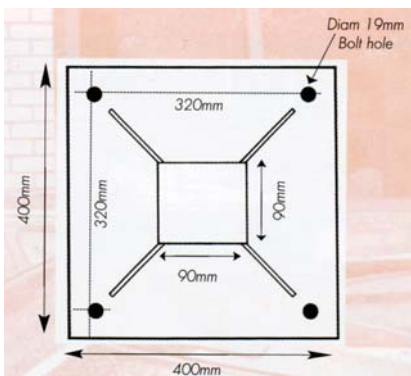

Base plate for fixed height restrictor

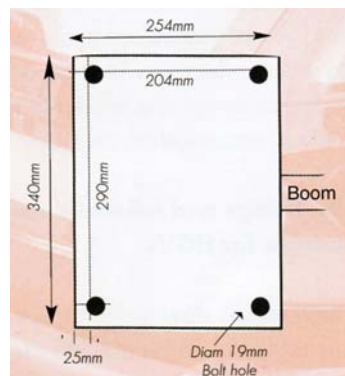

Base plate for catch post of swing height restrictor

▼ **Single barrier gate**

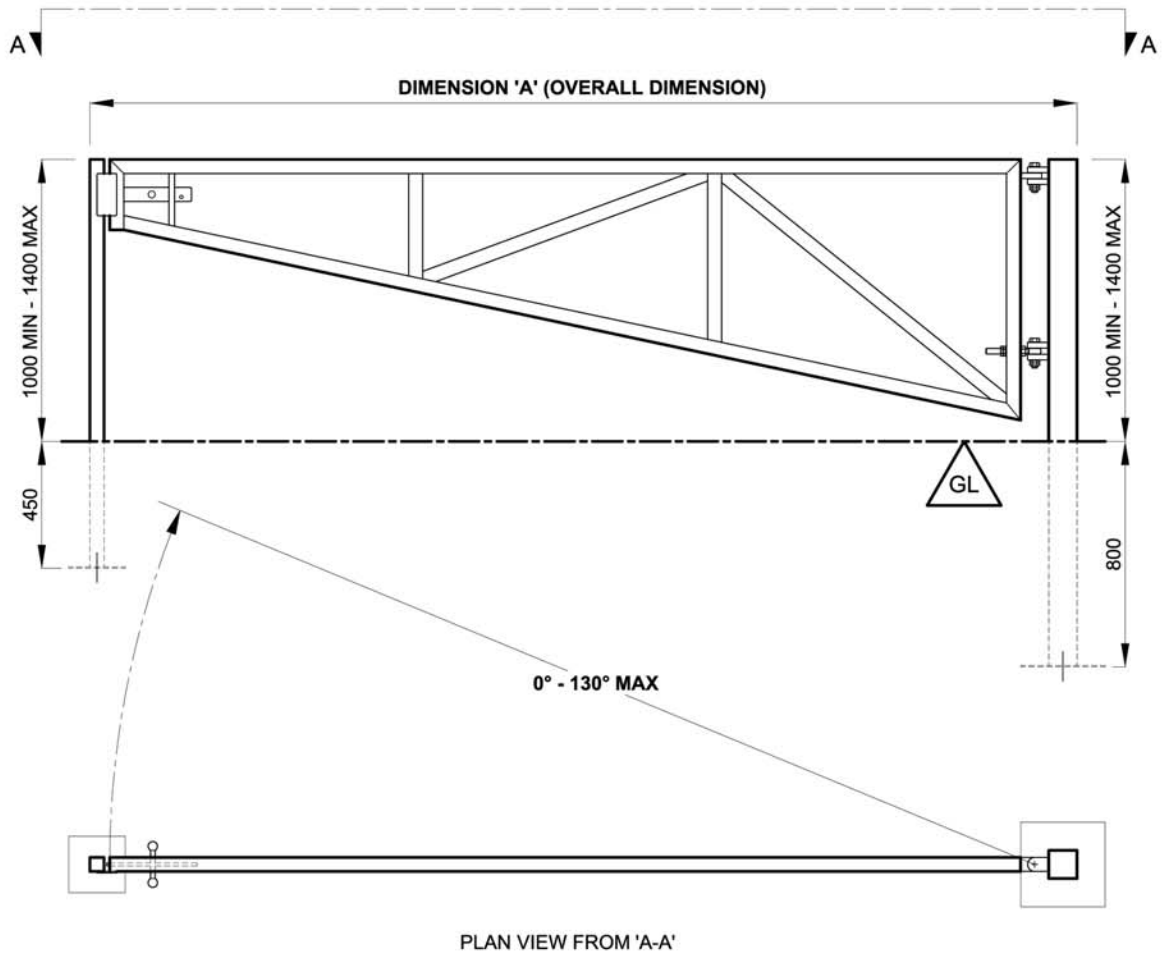

**TECHNICAL NOTES:**

MATERIALS SPECIFICATIONS TO **BSEN10025/BSEN10219**  
 VERTICAL BAR INFILL AND PITCHES TO **BS1722 Part 9**  
 GALVANIZED FINISH TO **BSEN1461:1999**

**UNIT LENGTHS:**

SINGLE BARRIER GATES ARE AVAILABLE IN STANDARD LENGTHS AND HEIGHTS (SEE BELOW), AND CAN BE ORDERED IN NON STANDARD LENGTHS TO SUIT.

**STANDARD GATE LENGTHS:** 1500mm, 2000mm, 2500mm

**STANDARD GATE HEIGHTS:** 1000mm, 1100mm, 1200mm

**ACCESSORIES:**

EACH SINGLE BARRIER GATE SET WILL BE SUPPLIED WITH 1 No. HINGE POST AND SLAM POST, SLAM PAD, ADJUSTABLE BTM HINGE AND A LOCKABLE SLIDING LATCH.

SF 11.10

**WHEN SPECIFYING YOUR ORDER PLEASE USE THE FOLLOWING PRODUCT CODE MATRIX:**

- 1) OVERALL LENGTH (DIM 'A'mm)
- 2) (SINGLE BARRIER GATE)

EXAMPLE: "(3000mm) SINGLE BARRIER GATE"

▼ Double barrier gate

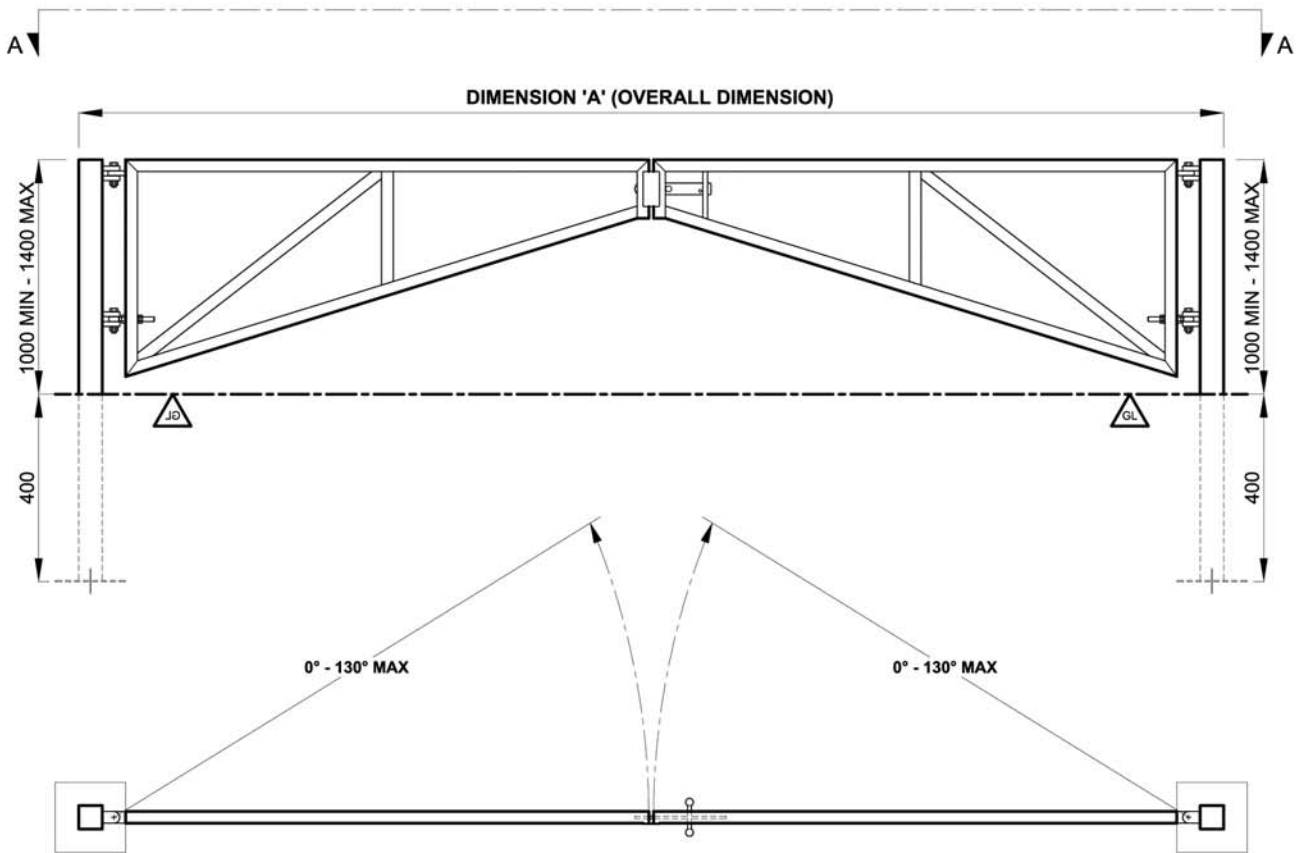

**TECHNICAL NOTES:**

MATERIALS SPECIFICATIONS TO **BSEN10025/BSEN10219**  
 VERTICAL BAR INFILL AND PITCHES TO **BS1722 Part 9**  
 GALVANIZED FINISH TO **BSEN1461:1999**

**UNIT LENGTHS:**

DOUBLE BARRIER GATES ARE AVAILABLE IN STANDARD LENGTHS AND HEIGHTS (SEE BELOW), AND CAN BE ORDERED IN NON STANDARD LENGTHS TO SUIT.

**STANDARD GATE LENGTHS:** 3000mm, 3500mm, 4000mm  
**STANDARD GATE HEIGHTS:** 1000mm, 1100mm, 1200mm

**ACCESSORIES:**

EACH DOUBLE BARRIER GATE SET WILL BE SUPPLIED WITH 2 No. HINGE POST AND SLAM POST, SLAM PAD, ADJUSTABLE BTM HINGE AND A LOCKABLE SLIDING LATCH.

**WHEN SPECIFYING YOUR ORDER PLEASE USE THE FOLLOWING PRODUCT CODE MATRIX:**

- 1) OVERALL LENGTH (DIM 'A')mm
- 2) (DOUBLE BARRIER GATE)

EXAMPLE: "(5000mm) DOUBLE BARRIER GATE"

SF 11.11

# ► Amenity Lighting Bollards



## ◀ Flat top bollard

- Classical slim line design
- Robust aluminium construction
- High performance polycarbonate refractive lens
- Fused cut-out with SWA cable terminations
- Large access door for easy installation
- Wide range of clour finishes available
- Finished in grey as standard

### Lamp options:

- 50W SON-E/I (internal ignitor) - E27 cap
- 50W MBFU Deluxe - E27 cap
- 9W TC-S compact fluorescent, 4000oK - G23 cap
- 100W (max) GLS - E27 cap

### Materials:

- Head - pressure die cast aluminium, multi-stage chromate pre-treatment, powder coated in grey finish
- Body - extruded aluminium, multi-stage chromate pre-treatment, powder coated in grey finish
- Lens - clear polycarbonate prismatic refractor

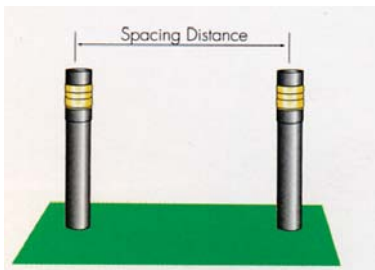
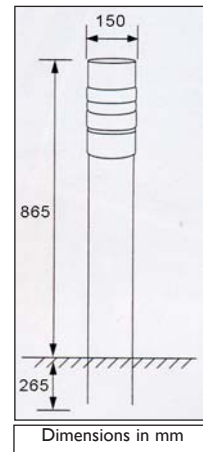

### Photometric data:

Cat No.	Spacing distance to achieve typical mid-point illuminance				
	15 lux	10 lux	5 lux	2 lux	1 lux
CBSE50	3.0m	5.5m	7.0m	9.0m	12.0m
CBME50	3.0m	5.0m	6.0m	8.0m	10.0m
CBCT209	3.0m	4.0m	5.0m	7.0m	8.0m
CBGE100	3.0m	4.0m	5.0m	7.0m	8.0m

## ▼ Dome top bollard

- For use in pathways, walkways, urban spaces, piazzas
- Robust, complies with BS EN 60598 - good value and available in two sizes
- IP65 - very good protection against weather for a long reliable life
- Extruded aluminium housing - tough and durable with a very weather resistant black powder coated finish
- Vandal resistant diffuser - the clear ribbed UV-

resistant polycarbonate diffuser will withstand rough treatment

- Versatility in lamp choice - the wide range of lamp types accommodated makes for a very versatile luminaire
- Choice of bases - the zinc coated base plate is standard but a root mounted version is available for greater strength
- Range of options - including a 3-hour integral emergency version, photocell control and a white housing

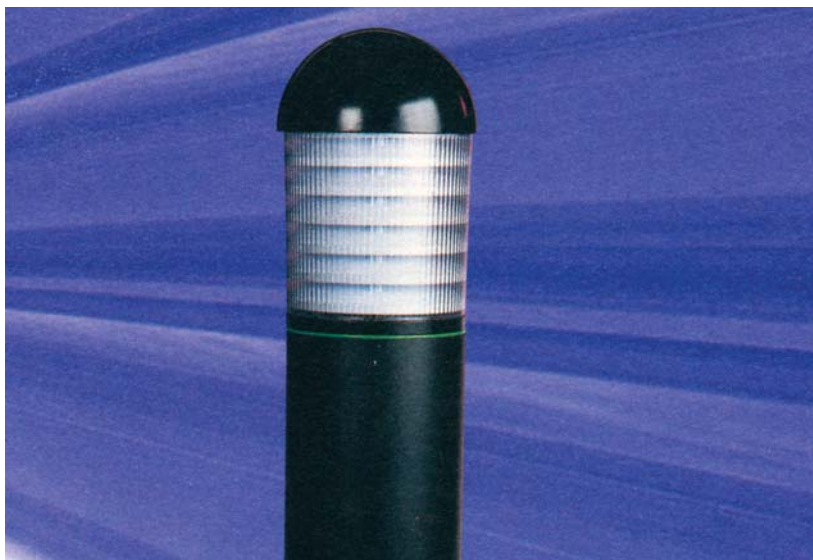
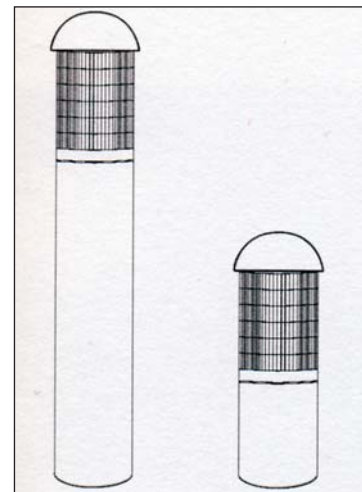

### Technical data:

- Two body sizes - available in 500mm and 1100mm heights, extruded aluminium
- Finish - black powder coated as standard
- Lamp types - 70W SON, 80W and 125W MBF/U and 2 x 18W TCD/CFL

### Dimensions:

Type	Height mm	Diameter mm	Weight Kg
500	500	180	5.8
1100	1100	180	8.5





### ▲ Safelite 100 square PHZ100

May be used singly or built up into virtually any combination of colour signals and can incorporate a flasher unit. The modules are moulded with integral hoods in impact-resistant self-coloured polycarbonate, with 100 x 120mm rectangular Fresnel lenses. Maximum recommended lamp wattage is 40W.

Heads may be wall or pole mounted using swivel brackets. They may also be mounted against a pole with push fit end caps in place of brackets.

### ▼ Safelite 100 round PH100

May be used singly or built up into virtually any combination of colour signals and can incorporate a flasher unit. The 150mm square modules are moulded with integral hoods in impact-resistant self-coloured polycarbonate, with 100mm dia Fresnel lenses. Maximum recommended lamp wattage is 40W.

Heads may be wall or pole mounted using swivel brackets. They may also be mounted against a pole with push fit end caps in place of brackets.



### ◀ ▼ Range of polycarbonate signal heads

- Widely accepted for use in loading bays, car parks and dock levelling installations, plus many other special applications
- Maintenance free, self colour polycarbonate housing in black (grey and other colours available)
- Modular - can be built into multiple aspects
- E27 Edison screw optics with Fresnel (100mm) and spiderweb (210 & 300mm) lenses
- Employs swivel mounting bracket or pole top fixing, both with enclosed cable entry
- Full range of coloured lenses, mounting fittings, control systems, cables
- Lamps available 240 & 110V in standard and long-life versions
- Vandal resistant lenses and door screws



### ◀ Safelite 210 round PH210

May be assembled up to five aspects and can have a flasher unit inside. The 320mm high by 270mm wide units are 410mm deep overall with slot-in polycarbonate hood or 210mm in depth without hood. Fixing arrangements are very flexible, with a choice of spigot, pole top fittings or angle brackets to fit any surface. In all cases signal head angle is adjustable and may be locked into position. Maximum recommended lamp wattage is 65W.

### ▼ Safelite 300 round PH300

May be assembled up to four aspects and can have a flasher unit inside. The 350mm high by 350mm wide units are 530mm deep overall with slot-in polycarbonate hood or 270mm in depth without hood. Fixing arrangement is by angle bracket to fit any surface. The signal head angle is adjustable and may be locked into position. Maximum recommended lamp wattage is 65W.



### ▼ Stop-Go light

- Fully conforms to EMC emissions - BS EN 55014-1:2001
- Manufactured to operate at 240V (alternative voltages available on request)
- Low power consumption
- Supplied with 6m cable

#### Body:

- Tough vandal resistant housing made from a single high density polyethylene moulding
- UV stabilised
- UL94 fire retardant test
- Fixed to various sizes of posts by means of stainless steel wall fixing brackets
- Vertical or horizontal fitting option

#### Lens pods:

- LED light source - selected for high light output
- Low maintenance - greater than 100,000 hour life expectancy
- 2 x sealed pods with 12 self-coloured LEDs
- Optically designed to maximise light output
- Vandal resistant polycarbonate lens



## ► Access Control



### ▲ ▼ ► Auto arm barriers

The Street Furnishings AU series of automatic rising arm barriers has been proven to provide a robust and reliable means of effectively controlling vehicular access. Suitable for a wide range of applications, the barriers are designed for constant use and incorporate advanced drive and logic control functions with a quiet and rapid operation.

The Street Furnishings AU barrier combines an elegant external appearance with a robust internal linkage and fixing system. The smooth operation of the barrier arm is provided by the combination of a powerful, controllable motor, accurate position sensing and custom-made counterbalance springs. The JD-78 logic control unit can accept inputs from a full range of access control actuation systems, including intercom, card control, radio remote and inductive loop technologies.

The AU-3.0, AU-4.5 and AU-6.0 barriers are manufactured to provide years of reliable service at the heart of a complete vehicle access control system

The AU barrier offers a high quality solution to vehicle access control situations where effec-

tive, flexible and swift control of traffic flow is required.

#### Specification:

**Cabinet:** 1030 x 350 x 350mm, 2mm steel. Polyester powder coated traffic blue/dark grey (other colours available). Lockable access door, internally latched removable lid.

**Linkage:** Zinc plated. Sinusoidal three arm drive linkage, adjustable. Clutch mechanism prevents damage if the boom is maliciously forced up.

**Arm:** 76mm o.d. aluminium tube, powder coated white. Red (class 2) reflective banding.

**Counterbalance:** Dual tension spring, micro adjustment.

**Motor:** Torque 55 Nm max. Manual arm release mechanism. 0.37kw 3-phase motor, supplied through inverter. Single phase supply only required.

**Inverter:** Output torque control. Power conversion. Arm motion control.

**Logic controller:** JD-78 parking control logic. Master on/off switch. Override raise, lower and automatic operation. LED monitoring for operation and input status. Position sensing optical switches (additional mechanical fail safe).

**Power supply:** Single phase, 240v, 5amp.



## ▼ ► Range of control equipment

Street Furnishings offers a full range of remote, vehicle detection and access control equipment ideally suited to provide easy operation and effective access control for private car parks. All our control systems are sourced from market leading companies, each meeting the highest standards of manufacture and operation. Each control has been exhaustively tested with the AU barrier to guarantee compatibility and long-term reliability. All controls are supplied with full OEM manuals, installation instructions and warranties.



Radio remote transmitters & receivers

## ► Card technology

Magnetic stripe and proximity card technologies provide the ideal solution for controlling access for a large number of users. Each card is encoded with a site code and an individual number providing very secure access control and easy system management. Timed allocation and capture (magnetic stripe only) systems are also available.

The standard card controller provides a stand-alone, easily programmed card control system, featuring verify, void and add functions and a 4-digit site code and memory for up to 10,000 cards. Programming may be in batches or individually. The card controller may be used to link two readers together to control both entry and exit through a single barrier.



Magnetic stripe card reader



## ◀ Intercom

Intercom systems provide easy remote verification before allowing access - the most cost-effective means of providing visitor access through a barrier. Each intercom provides high quality audio, distinctive ringing tone and a barrier opening button on the handset unit. Intercom systems can be provided to cater for a wide range of situations and requirements. From controlling single or multiple barriers to single or multiple locations, each with a dedicated handset and selectable from the barrier.

Vandal resistant and integrated video systems are also available.

Single point intercom entry panel

## ► Induction loop & vehicle detectors

Inductive loop detectors and photoelectric cell systems can be used to control both raising and lowering of the barrier. Inductive loops detect metallic objects that pass through the conductive field they generate. Photoelectric cells use a reflective beam to sense an object as it passes. Closing and safety detectors lower the arm only once the vehicle has safely passed.

The AU barrier logic provides "rollback" protection. Should another vehicle be detected before the barrier is fully closed, the arm will automatically raise thus minimising any risk of damage to the vehicle or barrier.



Dual channel vehicle detector

## ◀ Remote controls

Push buttons and switches provide easy local control of the barrier - for barrier systems that are permanently manned. Alternatively, a key-switch can be fitted to the barrier cabinet and control override opening and closing controls (key may be removed from any position).

RF radio remote control offers a simple and reliable means of opening the barrier arm. With a large operating range and up to 150 transmitters for each receiver, the remote transmitter and receiver combination is ideal for barriers with a limited number of users, or as an additional control system.

## ▼ Warning systems - signs & beacons

A full range of signs is available that can be fitted to the barrier arm or on a separate post. Warning beacons (LED) can be integrated with the barrier giving permanent or flashing visual warnings. The LED beacons are available in red, white and orange.

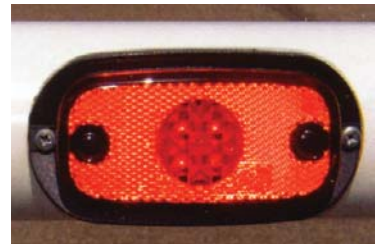

LED flashing beacon

## ▼ Override controls

During peak hours, especially on sites adjoining busy main roads, it may be desirable to allow the barrier arm to remain raised. The programmable timer allows the barrier to be raised during programmed periods and revert to fully automatic operation when required. The 7-day timer is fully programmable for single or multiple periods (day, combination of days and times). The barrier arm only closes behind the first vehicle outside of the time period (in conjunction with a closing detector).



7-day programmable timer

## Installation & layout

Site surveys are advised for all automatic systems to ensure correct, safe operation and selection of the most suitable equipment. Suitable signage is recommended to ensure drivers and pedestrians are aware of automatic barrier operation.

All installation work must be carried out by experienced and qualified personnel, ensuring that correct ground works and power supply are properly and safely completed in accordance with applicable statutory regulations.



## Code & token access

Numerical code keypads provide a vandal resistant, easily managed control system. Each keypad may be programmed with up to 50 entry codes of 4, 5 or 6 digits. A six digit manager's code provides re-programming security. A no-cash value token acceptor system provides easy control of vehicle access through a barrier - ideal for sites with large numbers of visitors. Usually combined with a "free entry" system.

Magnetic key systems are also available.

The layouts below are only for guideline purposes.

### Operation

### TYPICAL LAYOUTS

### Control Option

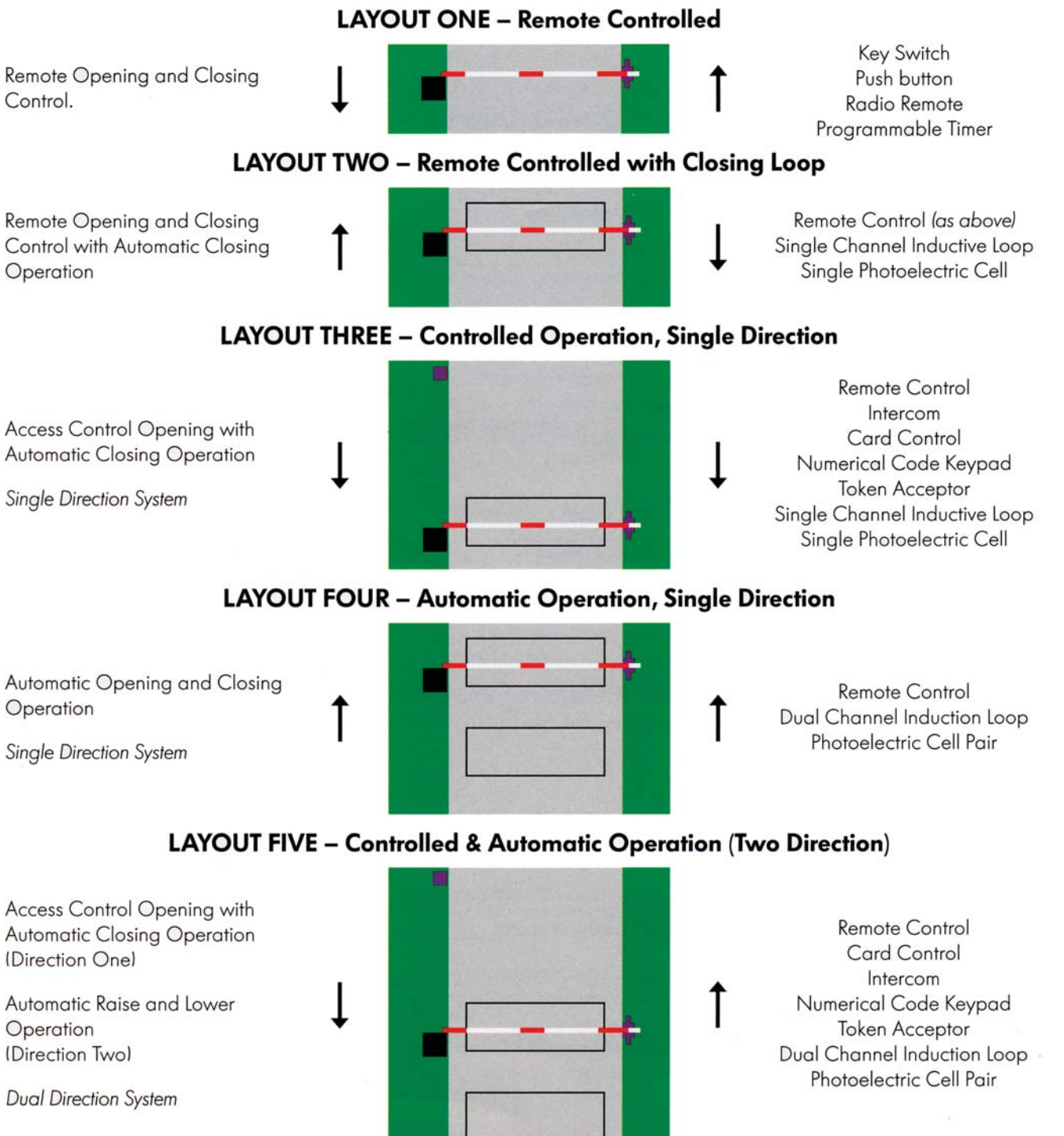

## ▼ Access control equipment - ordering information

ORDERING INFORMATION		Product Code
<b>AU3.0</b>	Automatic rising arm barrier with 3.0m arm (Pogo stick or fixed arm support <i>optional at extra cost</i> )	SF-138 105 301
<b>AU4.5</b>	Automatic rising arm barrier with 4.5m arm and ground fixed arm support.	SF-138 105 451
<b>AU4.5 Pogo</b>	Automatic rising arm barrier with 4.5m arm and arm fixed support.	SF-138 105 452
<b>AU6.0</b>	Automatic rising arm barrier with 6.0m arm and ground fixed arm support.	SF-138 105 601
<b>Single Channel Loop Detector</b>	24 v DC. Boxed. LED Power & Status. Self-tuning	SF-138 601 201
<b>Dual Channel Loop Detector</b>	24 v DC. Boxed. LED Power & Status. Self-tuning.	SF-138 601 202
<b>Induction Loop Cable</b>	100m drum	SF-138 601 209
<b>Photoelectric Cell</b>	Photoelectric cell and reflector. Post fixed.	SF-138 601 210
<b>Safety Strip (AU4.5)</b>	Pressure sensitive rubber strip, fixed to underside of barrier arm	SF-138 601 224
<b>Remote Control Button/Switch</b>	Up button and 3 position Rotary Selector (Raise/Auto/Lower)	SF-138 601 102
<b>Local Key switch Override</b>	Cabinet mounted 3 position key switch (Raise/Automatic/Lower)	SF-138 601 103
<b>Radio Remote Receiver</b>	Two Channel 150 user Radio Remote Receiver	SF-138 601 111
<b>Single Channel RF Transmitter</b>	One button Radio Remote Transmitter	SF-138 601 112
<b>Warning Beacon</b>	LED, Red, White or Orange, Arm or Cabinet fitted	-
<b>Plastic Skirt (AU4.5 only)</b>	Folding hanging skirt fitted beneath barrier arm	SF-138 105 920
<b>Access Control Stand Post</b>	Mild Steel, galvanised and flanged post. Painted Traffic Blue. <i>Required for items marked with an asterisk (*)</i>	SF-138 601 001
<b>Magnetic Stripe Card Reader*</b>	"Swipe" style magnetic stripe card reader	SF-138 601 311
<b>Magnetic Stripe Card</b>	Magnetic stripe card	SF-138 601 321
<b>Proximity Card Reader*</b>	5 cm read range Proximity card/tag reader	SF-138 601 312
<b>Proximity Card</b>	Passive Proximity Card	SF-138 601 322
<b>Proximity Tag</b>	Passive Proximity Tag	SF-138 601 323
<b>Card Reader Controller</b>	Controller for stripe and proximity readers.	SF-138 601 301
<b>Intercom 1.1*</b>	Entry panel (one backlit push button), controller and handset.	SF-138 601 401
<b>Numerical Code Keypad*</b>	Vandal Resistant 4, 5 or 6 digit entry code keypad	SF-138 601 510
<b>7 day Programmable Timer</b>	12 v DC Timer	SF-138 601 501
<b>Token Acceptor*</b>	No Cash Value Token Acceptor	SF-138 601 520
<b>Token</b>	No Cash Value Token	SF-138 601 521

# ► Cones, Cylinders & Lamps

## ► Recycled cone

- Our most popular cone.
- 450mm fitted with DES2 cat sleeve
  - 750mm self-weighted



50cm No Waiting Dominator

Mark II  
Plain

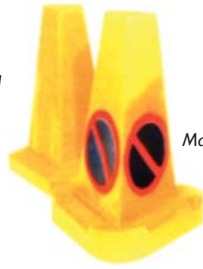

Mark II



Mark III

## ◀ No waiting cones

- Recycled
- Two-piece 500mm
- Tri-sided

## ► Two-piece cones

- Fitted with DES2 cat sleeve
- Heavy recycled base for good stability
- Excellent for staking
- Totally complies with BS873
- Available in 500mm, 750mm & 1000mm



## ▼ Traffic cylinders and bases



Unibase



Glue Mat



Asphalt Fixing Bolts

## ▼ Temporary road studs

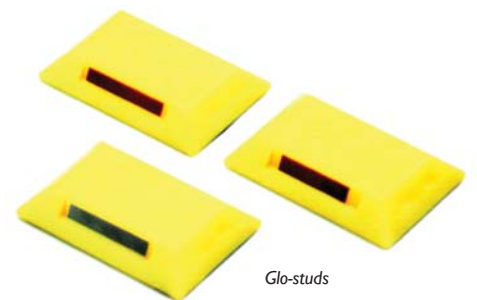

## ▼ Flashing lamps



Glo-Post  
75cm/30" and 45cm/18" heights available



Springback Cylinder Post with Unibase  
75cm/30" and 45cm/18" heights available



Microlite 2



Minilite



Lamp Cone Bracket

## ▼ Titan barrier 2-metre and 1.5-metre



1.5 metre Titan barrier



2 metre Titan barrier

## ▼ Smaller manhole barrier sets

Highly portable systems.



Hazard Moorgate barrier



Hazard Moorgate barrier - black chevron



Moorgate barrier 3 gated



Manhole kit



Champion manhole barriers - available in three designs

## ► Cone barrier system



75cm Roadhog slotted barrier



75cm slotted two-part cone barrier



Mark V cone converter fits Fleximan end-capped boards



Mark V cone converter fits Turret end-capped boards

## ▼ Temporary barrier systems



JWeb fencing

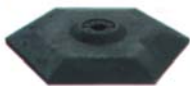

Bodyline base



JWeb fencing with JWeb upright and sand-filled base



Metal fencing support pins (do not comply with Chapter 8)



Zebra tape

# ► Traffic Separators

## ► Utility traffic separator

Available in two different lengths and several colour options, the Utility is highly versatile. It is sturdy enough for use in permanent situations if required or it can form a roundabout with a diameter of 4.5m upwards.

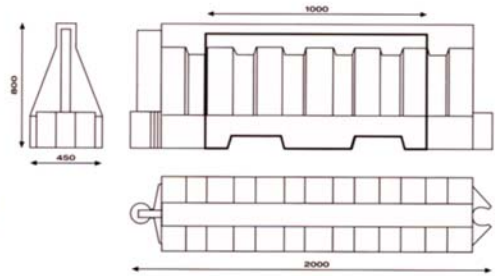

- Integral linkage system negates the need for pins or bolts
- Easy to assemble jigsaw fixing
- Lightweight for easy transportation and positioning
- Maintenance free
- Optional logos and colours available at extra cost
- Can be part filled with sand, gravel or water



## ▼ Pozecone traffic separator

The innovative design of the Pozecone combines a traffic cone and traffic kerb into one unit. It is totally unique and highly cost-effective.

Ideal for use as a safety barrier, it can equally be utilised for traffic management purposes. A spacer unit and corner piece make this system exceptionally flexible for all locations.

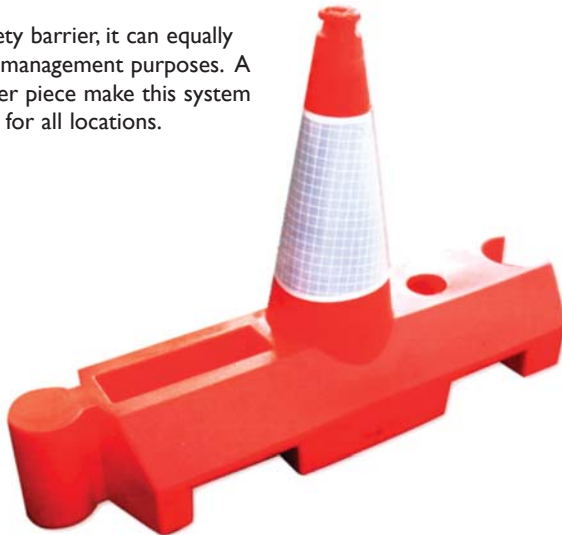

- Exceptional stability in poor weather conditions
- Much higher visibility than standard cones
- Positive fixing
- Tough, durable one-piece moulding with integral jigsaw fixing
- Can be filled with either sand or water
- Stackable for easy transportation and storage
- Handle recess for either forklift or manual handling
- Standard D2 sleeve, other options available

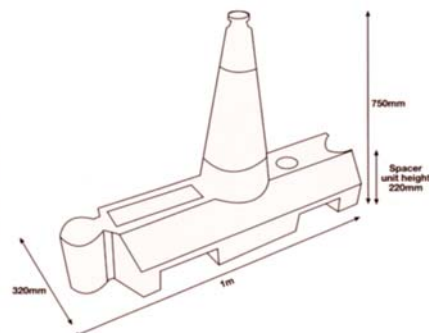



## ▼ Bee Hive bin

- Full 290o opening
- Capacity 8.8 CUFT (250 litres)
- Excellent nesting, perfect for summer storage

### Dimensions:

Height (measured at back)	704mm
Depth (measured back to front)	600mm
Width	1050mm
Weight	15Kg



## ◀ Grit/salt bin

Moulded in tough polyethylene with a one piece fully integrated hinge arrangement. They are vandal resistant and completely rot proof. The lettering 'Grit' is embossed into the moulding providing permanent identification. Standard colour supplied is yellow. Non-standard colours, additional lettering or plates for personal identification can be fitted at extra cost. Drain holes are provided in the base.

Type	Capacity				Height		Depth		Width	
	ft <sup>3</sup>	m <sup>3</sup>	cwt	kg	ins	mm	ins	mm	ins	mm
A	6	0.17	4	204	28	712	26	661	26	661
B	12	0.34	8	407	30	762	28	712	32	813

# ► Cycle/Perimeter Barriers

## ▼ Sheffield cycle barrier/stand

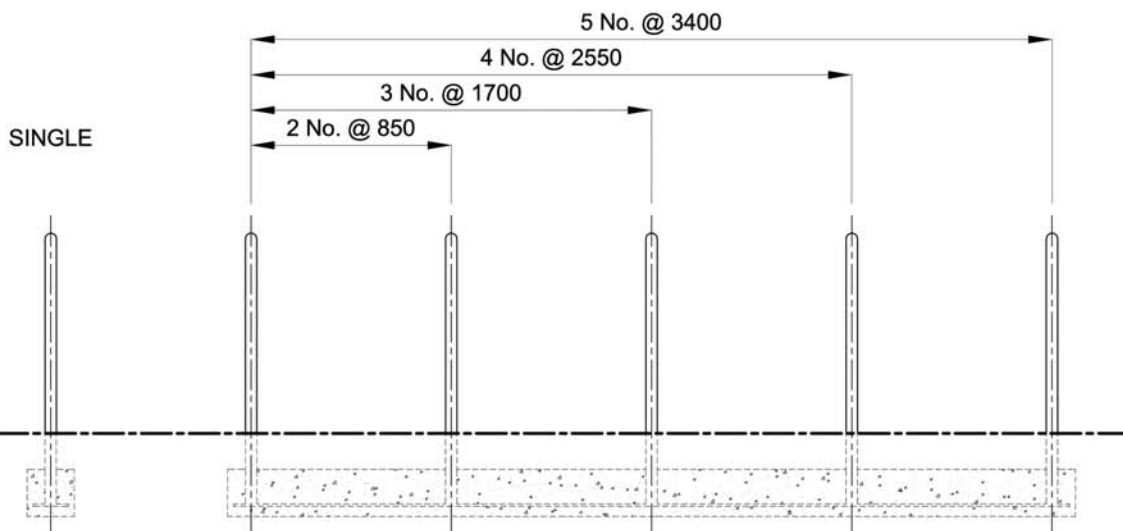
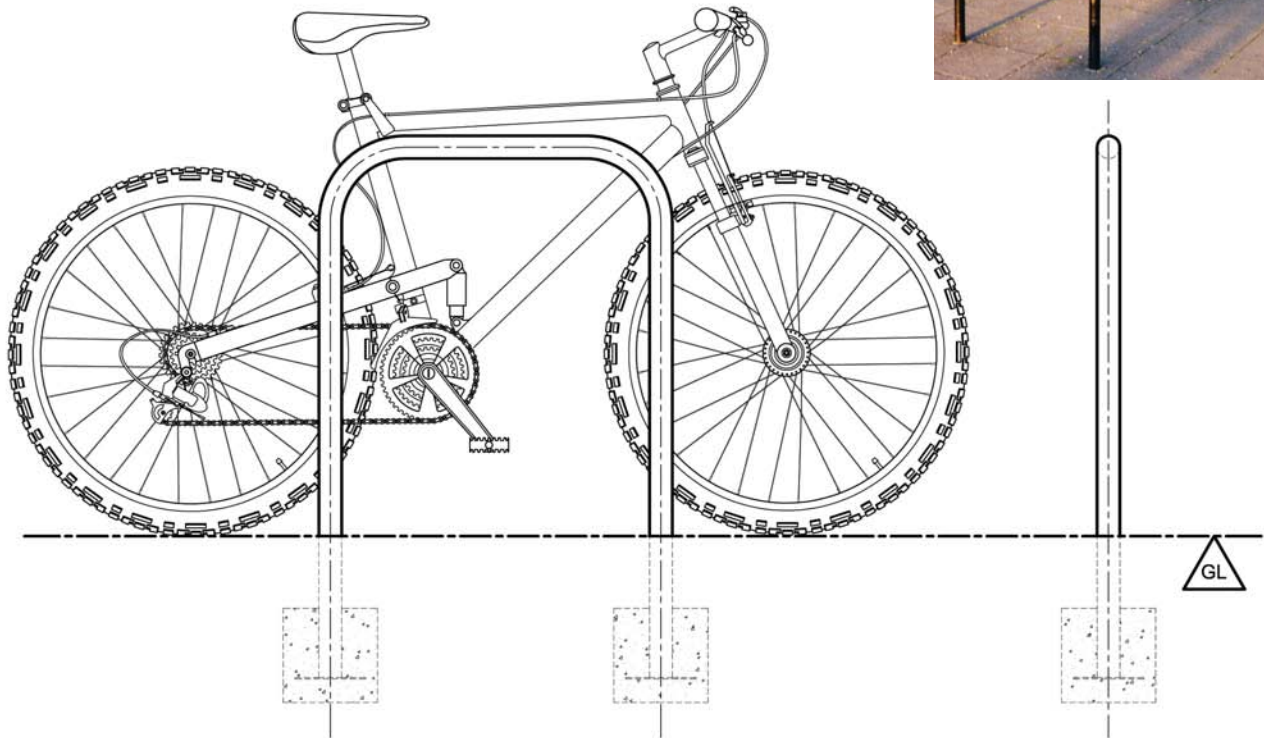

**NOTE: ALSO AVAILABLE WITH BASE PLATES FOR FLOOR FIXING**

**WHEN SPECIFYING YOUR ORDER PLEASE USE THE FOLLOWING PRODUCT CODE MATRIX:**

- 1) OVERALL LENGTH (SINGLE / 850mm / 1700mm / 2550mm / 3400mm)
- 2) (FLOOR MOUNTED CYCLE STAND)

**EXAMPLE: "(SINGLE) FLOOR MOUNTED CYCLE STAND"**

SF 14.10

## ▼ Perimeter barriers

To help secure site perimeters and provide a permanent obstacle to vehicle access. Also used to secure motorcycles. To mark boundaries, form trolley parks and protect vulnerable door entrances and exits.

- A variety of sizes and configurations are available in 48mm, 64mm or 76mm diameters as shown below (others available to order)
- Available ragged/spiked for casting in or flanged for bolting down
- Finishes available: galvanised, stainless steel, powder coated or painted (others to specific order)

- Manufactured from mild steel tube to BS1387 or BS8232/5 ERW
- 76mm barriers can be supplied in a removable version - lockable by ground sockets and padlock
- Grade 304 stainless steel is standard, but grade 316 can be supplied to order for marine and other demanding environments

### Installation:

Barriers should be cast into concrete a minimum 300-400mm deep by 300mm diameter or bolted where applicable to an existing concrete surface or similar.



64mm o.d 390 x 580mm above ground



Flanged perimeter barrier



Removable perimeter barriers

### Perimeter barriers Specification

o.d. (mm)	Wall thickness (mm)	Additional vertical leg	Additional horizontal rail	Length (mm)	Height above ground (mm)	Height below ground (mm)	Weight (kg)	Finish	Material grade steel
48	3.2	no	no	1000	500	300	10.0	Galvanised	Mild
48	3.2	no	no	2000	500	300	14.0	Galvanised	Mild
48	3.2	no	yes	2000	1000	300	23.0	Galvanised	Mild
50	2	no	no	750	750	300	9.0	Brushed	304 SS
50	2	no	yes	1200	750	300	11.0	Brushed	304 SS
64	3.25	no	no	390	580	300	8.0	Galvanised	Mild
64	3.25	no	no	1000	1000	400	21.0	Galvanised	Mild
64	3.25	no	no	2000	1000	400	26.0	Galvanised	Mild
64	3.25	no	yes	2000	1000	400	31.0	Galvanised	Mild
76	3.65	no	no	1000	1000	400	25.0	Galvanised	Mild
76	3.65	yes	no	2000	1000	400	32.0	Galvanised	Mild
76	3.65	no	yes	2000	1000	400	40.0	Galvanised	Mild

Mild = Mild steel tube    SS = Stainless steel

Many other heights and lengths (up to 2.5m) available - please ask for quotation

# ► Portable Guardrailing

## ▼ Portable guardrail

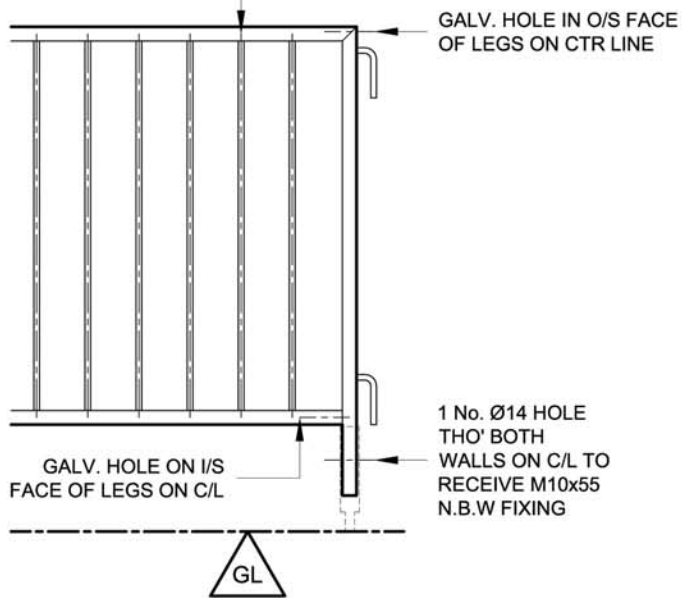
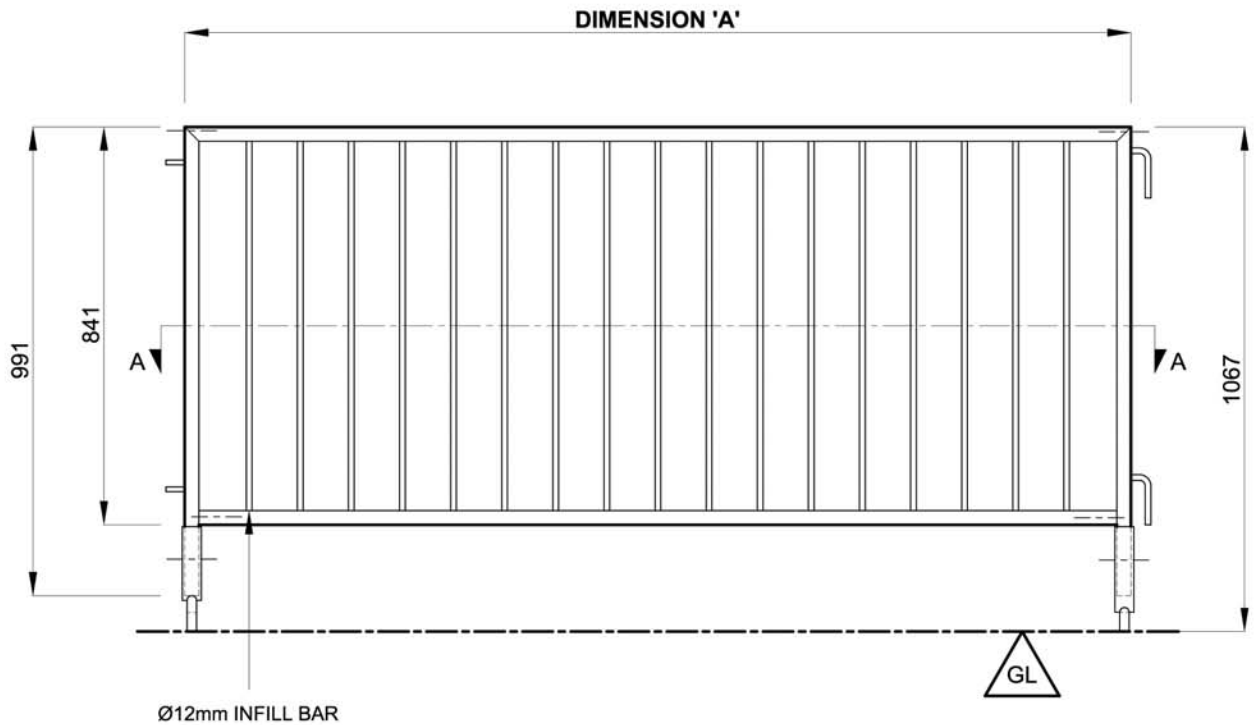

**PANEL END SECTION**  
(SHOWING MALE CONNECTORS)

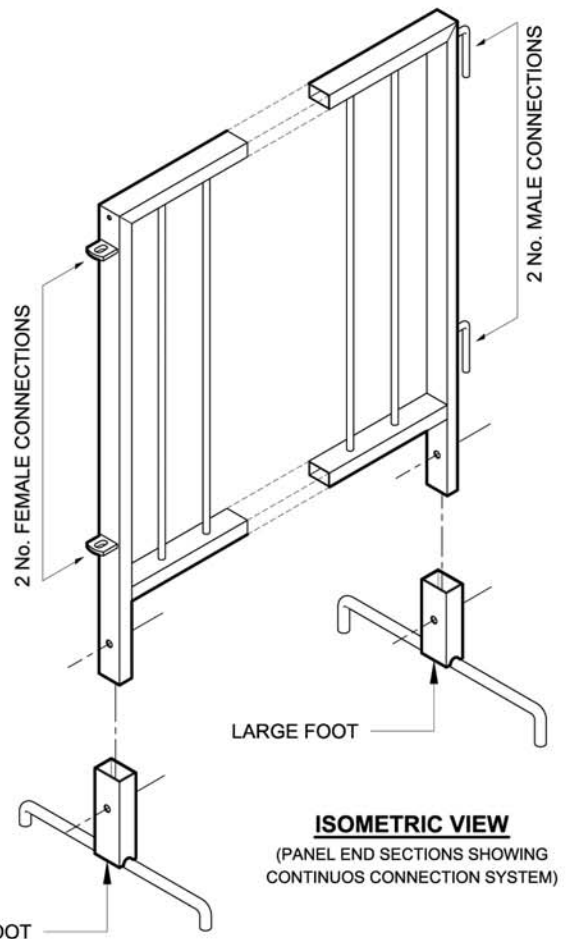

SF 5.10



Warehouse rail

## ◀ ▼ Column protection

Column protection units can be supplied in diameters as low as 500mm and are an ideal, cost-effective method of protecting lighting columns, structural columns, racking supports or similar. They are also available in a light-weight monostrut construction that can be installed down to as little as 400mm diameter.

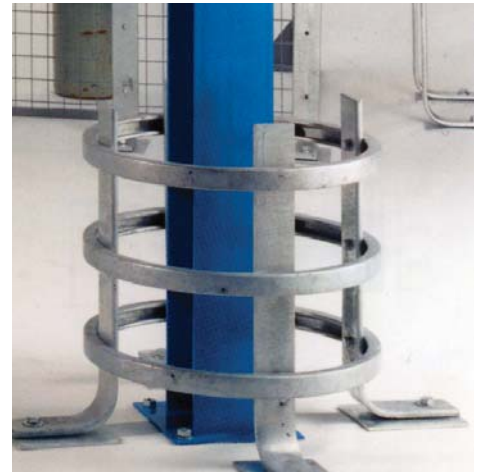

Monostrut rail

## ▼ Prefabricated column protector

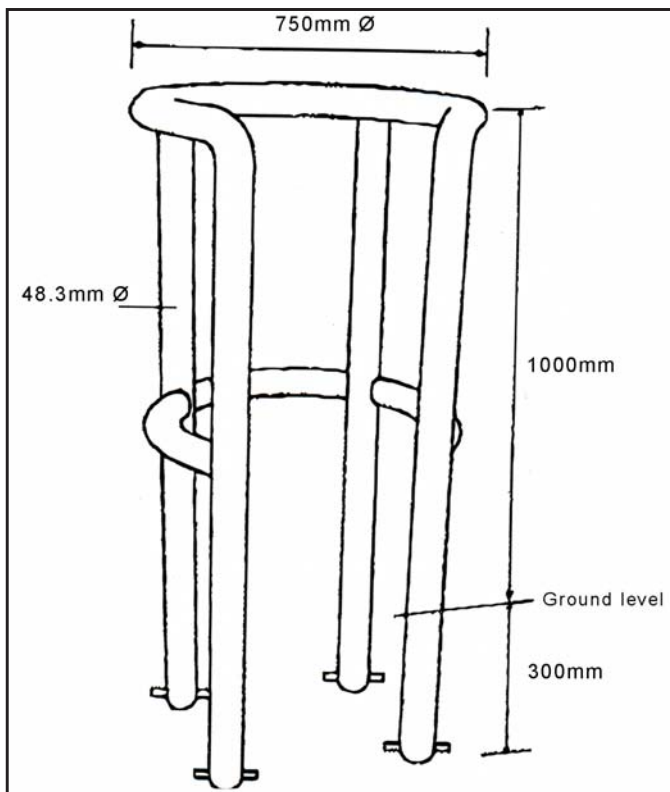

## ► Bolt-down bollards

Ideal for use as protection for columns.



# ► Rubber Barrier Protection

## ▼ Rubber barrier protection systems

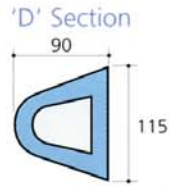

Standard length: 3000mm  
Material: EPDM Rubber  
No pre-drilled fixing holes

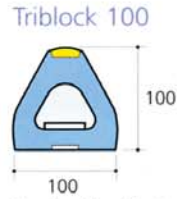

Standard length: 1m  
5 pre-drilled fixing holes

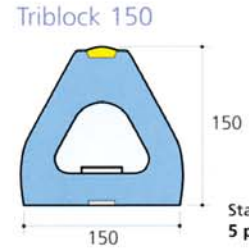

Standard length: 1m  
5 pre-drilled fixing holes



Standard length: 1m  
5 pre-drilled fixing holes

**Wall Fender**

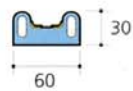

Standard length: 3m  
No pre-drilled fixing holes  
No fixings supplied

**Column Corner Guard**

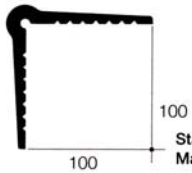

Standard length: 1200mm  
Material: EPDM Rubber

**Corner Fender**

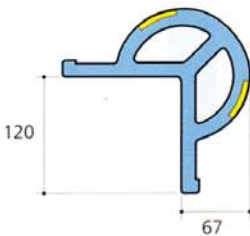

Standard length: 1m  
No pre-drilled fixing holes

**Kerb Stopper**

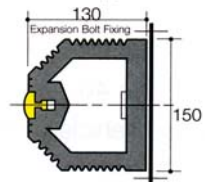

Standard length: 2500mm  
Material: EPDM Rubber

**Wallguard Section**

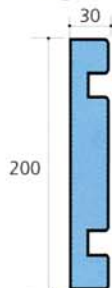

Standard length: 3000mm  
Material: SBR Rubber  
No pre-drilled fixing holes

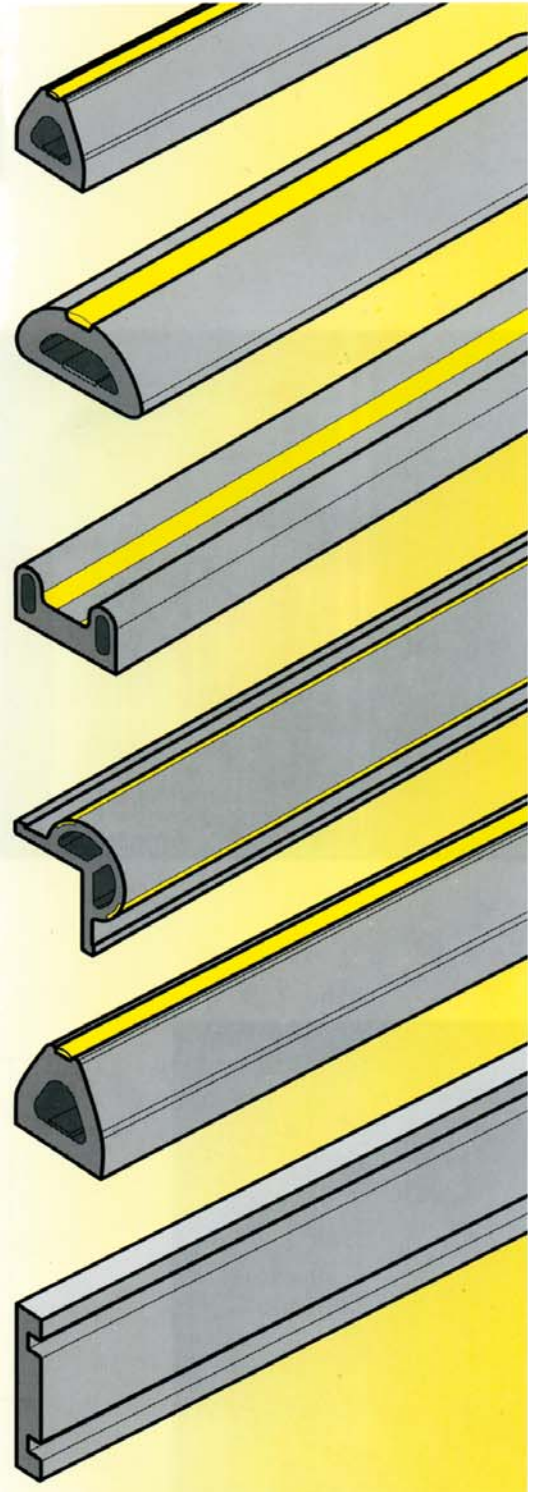



## ▶ ▶ Hercules flexible bollards

Hercules bollards are impact absorbing and can deflect to an angle of 18° and still return to their original position. Stylishly designed and incredibly tough, Hercules are the ideal solution for protecting doors, loading bays, machinery and personnel.

They can be surface mounted or cast in.

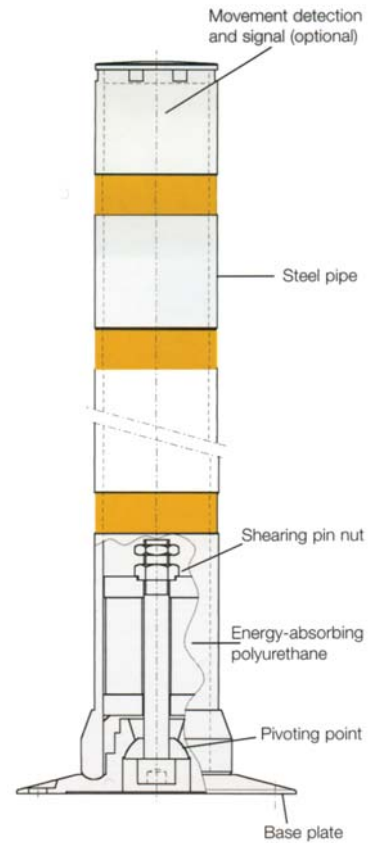

## ▶ ▶ Flexi-bollards

Flexi-bollards provide single point impact protection and are operational up to impacts of five tonnes. With built-in EPDM impact strips and high strength steel RSJ, the posts are finished in a high visibility yellow to add to the protection provided.

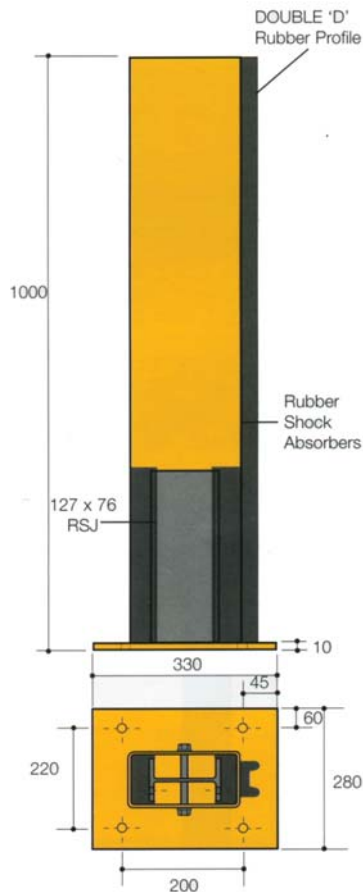

All dimensions in mm

# Car Park Crash Barriers

## Armco barrier

The untensioned system is designed only for use in situations where speed limits do not exceed 50 mph.

### Specification:

The main beams together with adjuster and anchorage beams are formed from stock 3mm thick steel complying with BS EN 10 025 Grade Fe 430A. Each standard beam has a 3.5m overall length (3.2m effective) and a nominal depth of 310mm.

There is no restriction on the installation lengths of untensioned safety fence beams, but all approach and depart ends must be taken down to ground level with the use of a formed beam and terminated with an end shoe, subsequently filled with concrete.

Alternatively, untensioned beams can be transitioned to the open box beam series if it is intended to terminate the safety fence at a bridge parapet or structure.

Usually, untensioned beams are mounted on 125mm x 90mm steel 'Z' section posts manufactured from stock 6mm thick steel.

Normal spacing of posts is 3.2m for untensioned safety fences, but post spacing can be reduced to 1.6m centres for improved protection at special hazards or where situations restrict deflection.

For projects such as car parks, loading bays, etc. stronger SHS posts or special mounting brackets are available.

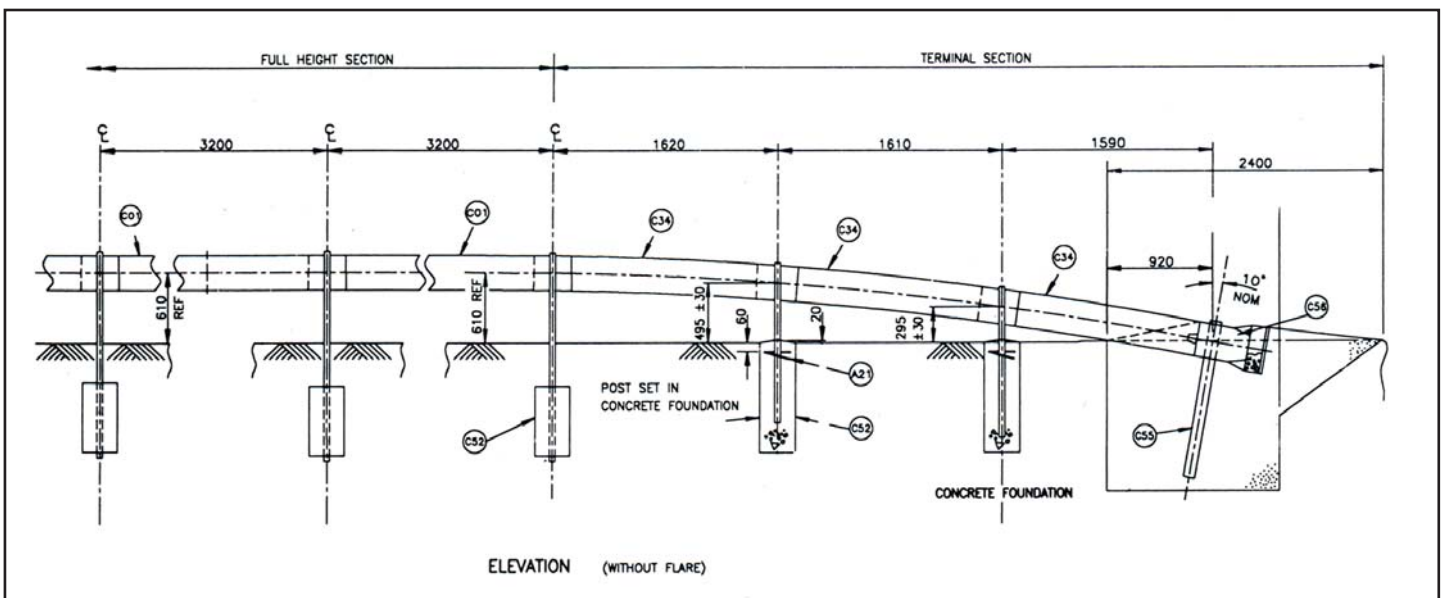



### ▼ Rigid steel barrier posts

In car parks or loading areas where vehicle contact is more frequent but less severe, a more rigid support is required. Rigid steel posts mounted in concrete provide an answer. Specially fabricated bolt-down posts are required when barriers are mounted on bridge decks, floor slabs or foundation blocks.

- Car parks
- Logistics depots
- Protecting structures



All dimensions in mm

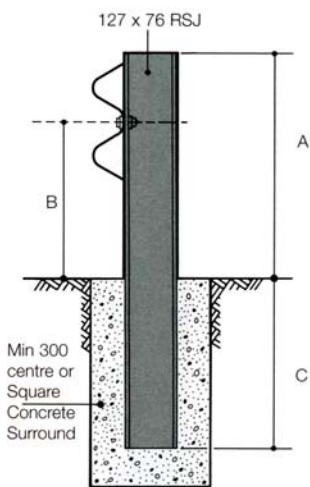

### ◀ Rigid steel posts

Typical arrangement at RSJ post in concrete surround.

P224 Type 3/1.1			P224 Type 3/1.5		
A	B	C	A	B	C
600	430	500	800	630	700



### ▶ Bolt down post

P224 Type 1*		P224 Type 2	
A	B	A	B
610	440	760	570

\*Car park height

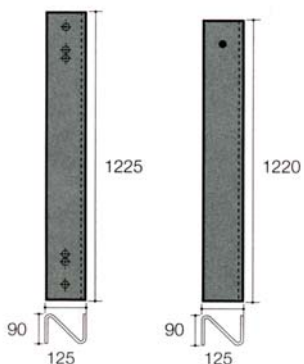
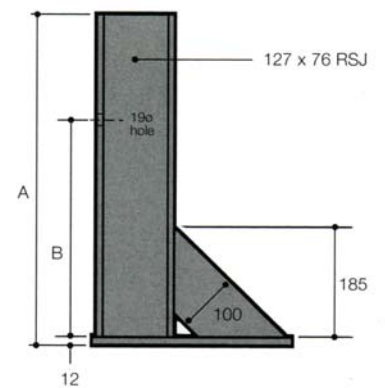

### ◀ 'Z' section posts

125 x 90 x 6mm 'Z' post, available in 1225mm lengths. Suitable for general contracts and for use with offset bracket.

125 x 90 x 5mm 'Z' post, available in 1220mm lengths.

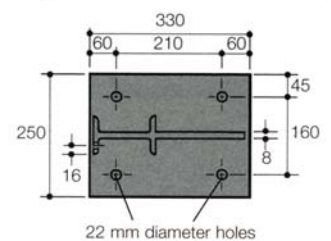

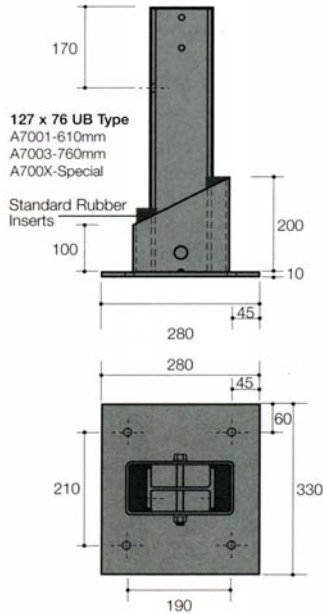
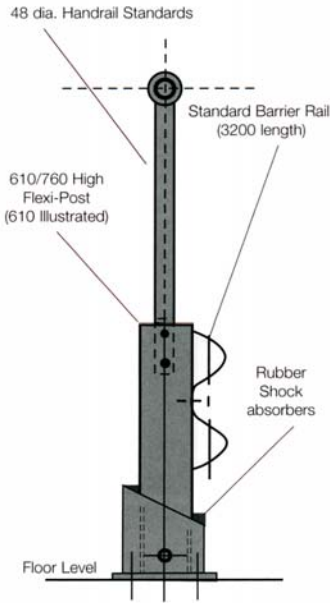

## ◀ Flexi-post diagram

All dimensions in mm

## ▼ Spring steel buffers

Designed to absorb impact loads of up to 40 tonne heavy goods vehicles, these buffers will significantly reduce barrier replacement and maintenance cost.



### Spring Steel Buffers

**GH Type**  
76 x 10mm

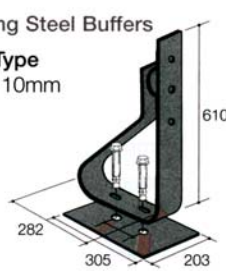

**RB1X Type**  
100 x 14.3mm  
foot length 300mm  
Also available  
76 x 12.7mm  
foot length  
200mm

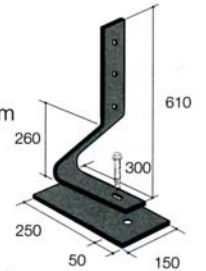

**RB1 Type**  
100 x 14.3mm  
foot length 300mm  
Also available  
76 x 12.7mm  
foot length 200mm

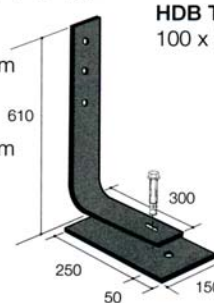

**HDB Type**  
100 x 20mm

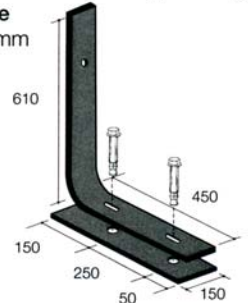

**Planted Post Buffer**  
complete with Sheath  
76 x 12.7mm

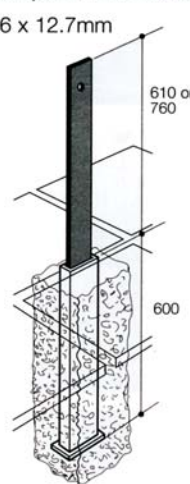

**Wall Mounted Buffers**

**WH Type**  
76 x 10mm

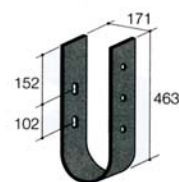

**WB1 Type**  
76 x 10mm

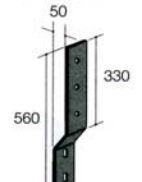

**Warehouse Rail Buffers**

**RB610**  
76 x 12.7mm



**RB235**  
76 x 12.7mm

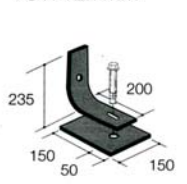

**Combined Beam & Balustrade**

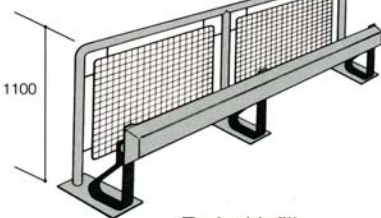

**Split Level Protection**

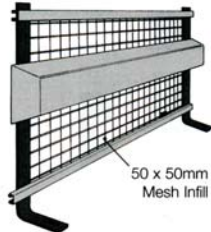

**Typical Infill System**

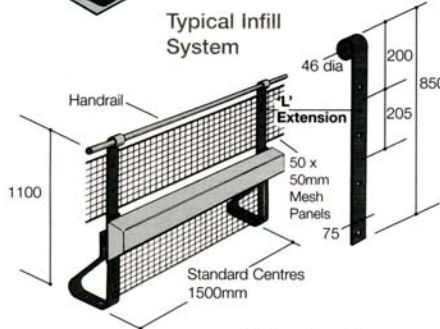

**Nudge Protection - Rubber Sleeve**

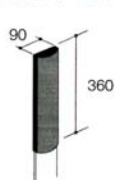

All dimensions in mm

▼ Accessories

▼ ► Pedestrian terminal end

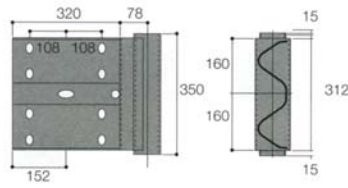
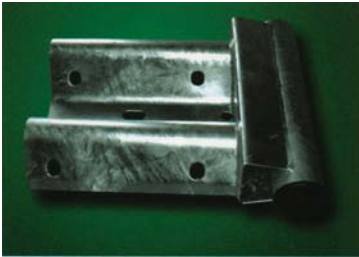

Pedestrian terminal end pieces make the transition from a deeply corrugated section with sharp ends to a safe, tubular profile with no protruding sharp edges and fitted plastic end caps. They are used primarily at the exit ends of parking spaces to protect pedestrians from injury.

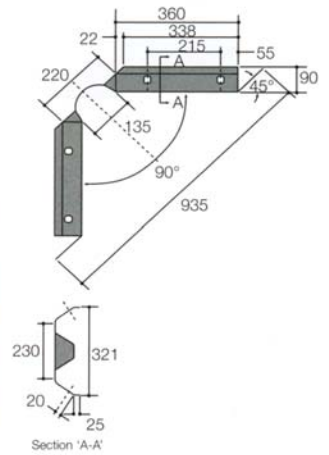
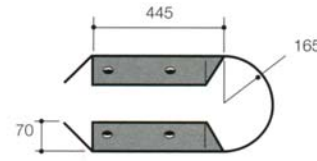

▼ Bullnose end

Flexible external corner

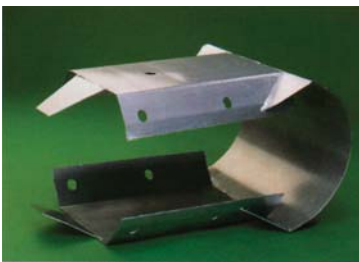

▼ Internal corner connector

Flexible

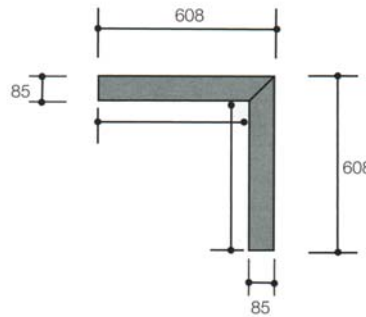

▲ Rigid external corner

Connector also available

All dimensions in mm

▼ Plastic end cap

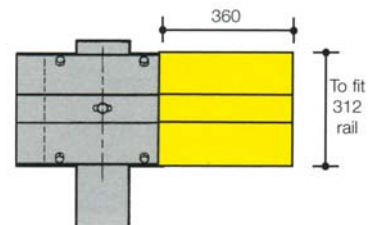
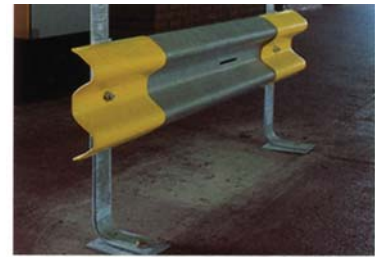

▼ Flexi-post (continued on next page)



Flexi-post barriers are manufactured using an untempered beam attached to flexible floor mounted posts. The unique engineered design allows them to be used for absorbing an impact of up to 10 tonnes. Extremely strong, easy to install and with a long operational life, Flexi-posts are the perfect protectors of people, plant and infrastructure.



## ► Traffic Flow Plates



### ▼ Restrictor traffic flow plates

Provide a robust and cost-effective means of controlling vehicle traffic.

#### Key features:

- Robust construction
- Ease of installation
- Manual operation
- Durable coating specification
- Modular design

#### Benefits:

- Low maintenance
- Cost-effective
- Spares availability

#### Technical specification:

The Restrictor traffic flow plate has been designed to provide a low cost answer to the problem of directional vehicle flow. Manufactured from heavy gauge steel plate and load bearing road surface plates constructed from 12mm durbar plate. The sub surface road box having external anchor plates for securing into the supporting concrete bed, a removable road surface plate is provided to allow access to the bearings and buffer pads.

This entirely mechanical, gravity controlled unit requires no external power source thus being low in capital and running costs and requiring minimal maintenance.

- 5mph maximum speed advised
- Maximum load 7.5 tonnes
- Sub-surface parts galvanised. Top plates galvanised and painted yellow
- Weight 26kg/unit

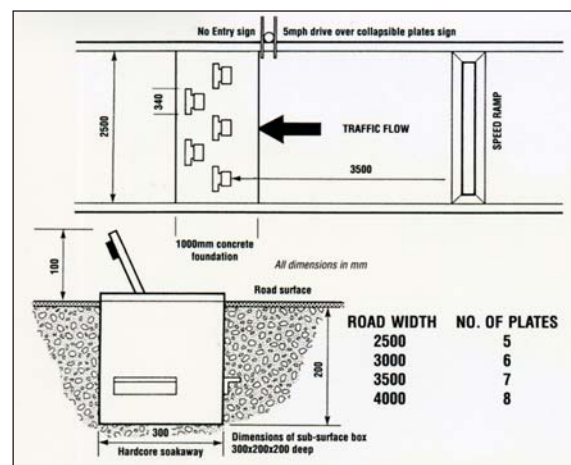

## ▼ ► Heavy duty traffic flow plates

Within any industrial or commercial site, car park or similar location there is a need to implement an effective traffic management system. Without any form of traffic control there is a security risk to the organisation, a risk of damage to other vehicle drivers and a risk of injury to pedestrians. A series of traffic flow plates offers a cost-effective solution to any traffic control problem. Designed for strength and durability, these traffic flow plates encourage a one-way traffic flow and prevent unauthorised entry/exit within any location, thereby enabling vehicle movement to be managed at all times.

With a heavy duty steel construction, these traffic flow plates can be used for any type of vehicle application, including HGVs. They have been uniquely designed to withstand the rigours of all types of road vehicle over an extended period and thus capable of giving long-term effective operation with only minimal maintenance.

It is important that warning signs and speed restriction units are installed in conjunction with traffic flow plates.



### Specification:

Dimensions: 250mm cube  
 Flap height: 110mm  
 Recommended speed: Not to exceed 10mph  
 Base material: Heavy duty steel plate  
 Top plate material: 8mm durbar steel  
 Finish: Galvanised primed & painted yellow



## ◀ ▼ Surface mounted traffic flow plates

An extremely strong and reliable unit designed for ultimate strength and reliability. It encourages one-way traffic flow and deters unauthorised entry/exit.

The surface mounted traffic flow plates offer a cost-effective solution to traffic control issues where standard fixed traffic flow plates cannot be used. Suitable for multi-storey car parks or where excavations cannot take place.

It is recommended that warning signs and speed restriction units are used in conjunction with traffic flow plates.

- Deters unauthorised entry/exit
- Encourages one-way traffic flow
- Rapid installation
- Low maintenance - no on-going charges
- Galvanised units available
- Greater security and traffic control
- Effective vehicle management
- Reduced cost
- Increased durability and wear

### Specification:

Dimensions: 255mm x 430mm  
 Raised height: 115mm  
 Recommended speed: Not to exceed 10mph  
 Base material: Heavy duty steel plate  
 Top plate material: 8mm durbar steel  
 Finish: Primed & painted yellow  
 Optional finish: Galvanised

### Installation:

Surface mounted traffic flow plates can be bolted to concrete or tarmac using special fixings which can be supplied.



## ► Speed Ramps



### ▲ ▼ ► BeeBump

A highly effective means of controlling traffic speeds. 50mm high slows to 10mph, 75mm high slows to 5mph.

- The modular system is formed from black and bright yellow segments made from heavy duty recycled PVC
- White reflectors in each section - excellent night time and bad weather visibility
- Both ends and inners are available in black and yellow
- Quick and easy to install by just one person with a drill and spanner
- All segments are sold separately
- Ramps of any length can be formed simply by combining modular sections

Speed restriction signs should be placed in a clearly visible position ahead of any ramp location.



Bolts and "dog bone" fixings included at no extra charge

#### Dimensions & weights of components:

50mm high inner segments:  
weight 8.0kg, length 500mm, width 420mm

50mm high shoulder pieces:  
weight 2.2kg, length 210mm, width 420mm

75mm high inner segments:  
weight 13.0kg, length 500mm, width 420mm

75mm high shoulder pieces:  
weight 3.2kg, length 210mm, width 420mm

BeeBump size chart Component parts						
Overall length of ramp	With shoulders				Without shoulders (eg kerb to kerb)	
	Inner (yellow)	Inner (black)	Shoulder (yellow)	Shoulder (black)	Inner (yellow)	Inner (black)
2.5m	2	2	1	1	3	2
3.0m	3	2	-	2	3	3
3.5m	3	3	1	1	4	3
4.0m	4	3	-	2	4	4
4.5m	4	4	1	1	5	4
5.0m	5	4	-	2	5	5
5.5m	5	5	1	1	6	5
6.0m	6	5	-	2	6	6



## ◀ ▼ Flexline preformed thermoplastic road markings

- Wide range of colours
- Material can be formulated for hot or cold climates
- Can be laid easily onto coloured anti-skid surfacing
- Reflective glass beads can be applied during heating
- Black Flexline can be used to black out existing markings
- Ideally suited for maintaining existing markings

## ▼ Accessories

Tack Coat, gas torches and other associated equipment available.

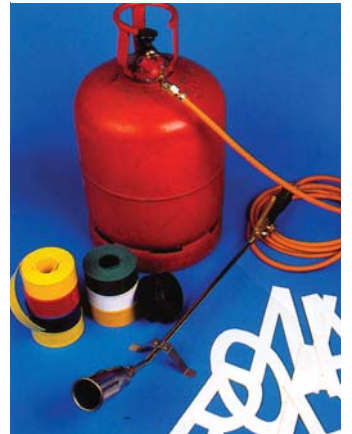

## ◀ Contractors spray paint

The contractor's answer to economic temporary marking.

- 728ml aerosol
- Temporary line and spot marker for low wear applications
- Fast drying

## ▼ Specialised logos & images



## Maintenance paint

We are able to supply any BS colour paint for use in the maintenance of your highway products e.g. bollards, posts.

## ▼ Stainless steel tactile studs

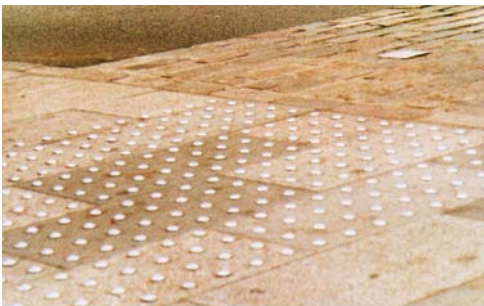

## ▼ Brass tactile studs

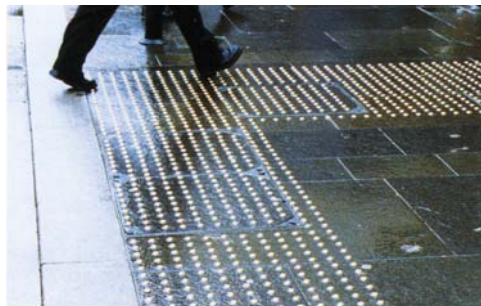

## ▼ Brass boundary studs



## ► Stainless steel roadstuds

Each stud is made from austenitic stainless steel (18% chrome, 8% nickel) specially heat treated which ensures maximum toughness, strength and rust resistance. Available with either fishtail or chisel shank designed and shaped to prevent twisting after installation. To assist skid resistance a serrated face is also available (chisel shank only). A superior quality roadstud appropriate for any type of road surface, its durability provides excellent cost effectiveness.

## ► Aluminium roadstuds

Each stud is cast from aluminium alloy conforming to BS1490:1988. Supplied with a raised profile to assist skid resistance and fishtail shank. Suitable for most road surfaces - a cheaper short-term alternative to the stainless steel type when a compromise on quality is a necessity.

All studs conform to BS873 Part 4.

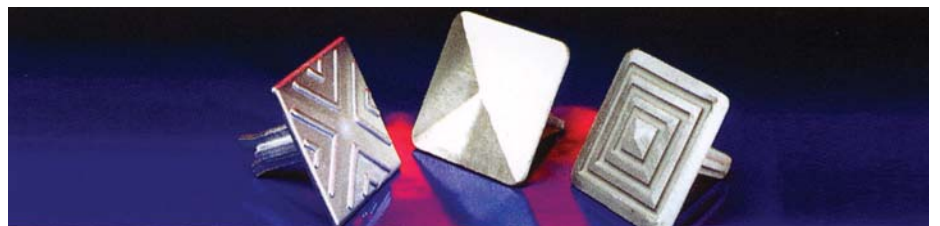

Measurements, types & weights						
Metal	Surface of stud			Shank of stud		Nett weight (approx) Grams
	Head shape	Nominal measurements mm	Type	Shape	mm	
Stainless Steel	Square	100x100	Plain face	Chisel	70±6	700
Stainless Steel	Square	100x100	Plain face	Fishtail	70±6	700
Stainless Steel	Square	100x100	Serrated face	Chisel	70±6	700
Aluminium	Square	100x100	Raised profile	Fishtail	70±6	210

## ► Industrial & Traffic Mirrors

### ▼ ► Industrial mirrors

Industrial mirrors made of modern plastic materials have a long life and resist impact. You can choose between impact-resistant acrylic (AC) or virtually unbreakable polyester (PET).

The mirrors are supplied with a zinc-plated bracket for mounting on a standard 50-76mm pole or on a wall. There are also models which are heated electrically to prevent moisture and ice formation.

An industrial mirror in the right place can help prevent accidents and provides greater safety when vision is blocked e.g. in truck aisles and narrow exits. The mirrors can also be used for security and monitoring automatic machines and conveyors. Since they are impact-resistant or virtually unbreakable, they are ideal for food and process industries.

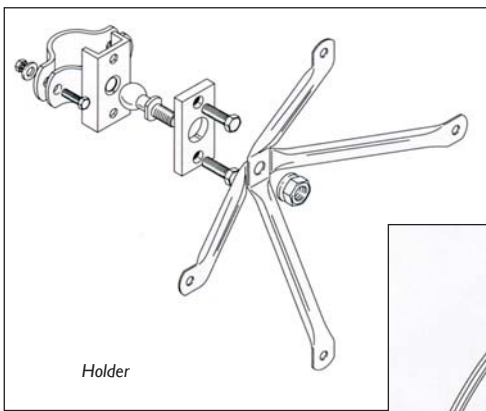

Holder

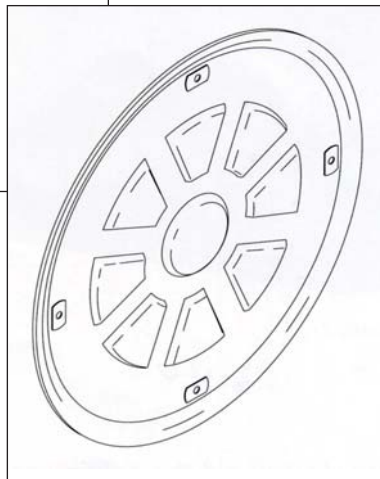

Rear view



Industrial mirror I-94



Industrial mirror I-94

Part no.	Type	Industrial mirror		Observing distance (m)	Material
		Size (mm)	Weight (kg)		
SF-14-34050	I-94	Ø500	2.4	10	AC
SF-14-34060	I-94	Ø600	3.2	12	AC
SF-14-34080	I-94	Ø800	5.4	18	AC
SF-14-34046	I-94	400x600	3.2	12	AC
SF-14-34068	I-94	600x800	7.4	18	AC
SF-14-34250	I-94	Ø500	2.4	10	PET
SF-14-34260	I-94	Ø600	3.2	12	PET
SF-14-34280	I-94	Ø800	5.4	18	PET
SF-14-34246	I-94	400x600	3.2	12	PET
SF-14-34268	I-94	600x800	7.4	18	PET

Designed for monitoring machines, warehouses, truck aisles, parking lots, etc. in industry. Packed individually with a bracket.



## ▼ ► Traffic mirrors

Traffic mirrors made of modern plastic materials are strong and will have a long life. You can choose between impact-resistant acrylic (AC) or virtually unbreakable polyester (PET). The frame is made of a reflecting Class 2 material to emphasise that the mirror is a traffic aid.

The mirrors are supplied with a zinc-plated bracket for mounting on a standard 50-76mm post or on a wall. There are also models which are heated electrically to prevent moisture and ice formation.

Traffic mirrors offer greater safety when vision is restricted - in built-up areas, opposite driveways and at intersections. They improve vision and thus safety of all road users. Since an outdoor environment naturally makes special demands, the mirrors are made of a plastic material which guarantees a long life under particularly difficult weather conditions.



Traffic mirror T-97



Traffic mirror T-97



Part no.	Type	Traffic mirror			Material
		Size (mm)	Weight (kg)	Observing distance (m)	
SF-14-34146	T-97	400x600	3.6	12	AC
SF-14-34168	T-97	600x800	7.9	18	AC
SF-14-34160	T-97	Ø600	3.5	12	AC
SF-14-34180	T-97	Ø800	5.8	18	AC
SF-14-34346	T-97	400x600	3.6	12	PET
SF-14-34368	T-97	600x800	7.9	18	PET
SF-14-34360	T-97	Ø600	3.5	12	PET
SF-14-34380	T-97	Ø800	5.8	18	PET

Designed to improve visibility for road users at intersections, on sharp curves, opposite driveways, etc. Packed individually with a bracket.

# Wheel Clamps

## Wheelok wheel clamp range

- Security of vehicles and forecourt areas.
- Control of illegal parking

All vehicles are at risk from theft, be they on garage forecourts, business premises, private car parks, public car parks or the private driveway at home. Nowhere is safe.

To prevent your vehicles falling easy victim to theft, you can now deter the thief with a wheel clamp from the Wheelok range. Government Home Office approved since 1983 and insurance company recommended, the Street Furnishings Wheelok range has wheel clamps to fit virtually any vehicle including trailers, caravans, cars, vans and HGVs.

Your vehicles deserve the best protection - choose Wheelok, the professional's choice for vehicle security.

As towns and cities become more congested with vehicles, parking regulations are being enforced in more and more locations with Wheelok wheel clamps. Introduced in 1983 for use by the London Metropolitan Police to control illegal parking, this model clamp is being adopted by many local authorities to enforce on-street parking regulations.

On private property, store complexes, colleges, universities and hospital car parks there is misuse by the casual parker which can be reduced by the Street Furnishings Wheelok range of wheel clamps.

## Super model 'A'

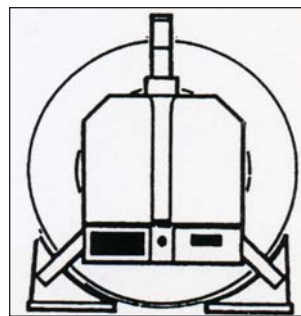

Colour: Yellow  
 Lock: Integral lock  
 Weight: 16kgs  
 To fit tyres: 145-195 width  
 Wheels 13" 14"  
 Accessories: Swivel chock to fit twin axle caravans, trailers, etc. Close fitting hook arm for caravans, trailers and other vehicles with close fitting low wheel arch trims.  
 Applications: A versatile model for cars, vans, caravans & trailers

## Police model II

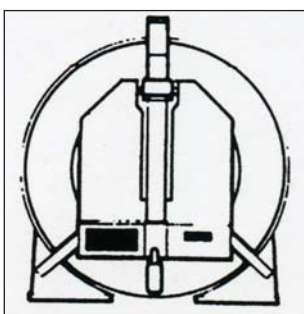

Colour: Yellow  
 Lock: Padlock  
 Weight: 24kgs  
 To fit tyres: 165-265 width  
 Wheels 14" 15" 16"  
 Accessories: Extended hook arms to fit tyres greater than 27" in height and up to 11.5" wide.  
 Applications: Control of illegal parking. Also used for high security of cars, vans, plant hire machinery and up to 7.5 tonne trucks.

## HGV model 'C'

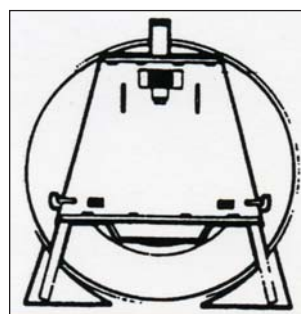

Colour: Yellow  
 Lock: Padlock  
 Weight: 63kgs  
 To fit tyres: Small HGV dia. 33" to 42.5" in height  
 Large HGV dia. 36" to 45.5" in height  
 Tyre width 10.25" to 15.25"  
 Applications: Vehicle security of HGVs, large trucks, trailers, coaches, JCBs, etc.

## ► The Professional wheel clamp

Street Furnishings innovative world-beating Professional wheel clamp range offers a solution to every enforcement need. Our clamps are designed with the needs of the professional user in mind. The accent is on ease of use, coupled with unparalleled security.

No. 1 clamp in the UK market, the Professional offers superior performance to meet the demanding needs of the professional operator. The Professional will enable your team to clamp any vehicle from a Mini to a Range Rover. The wheel clamp will fit tyre sizes from 145 to 225.

- Home Office Approved
- In use by DVLA, Councils and major car park operators
- Robust and extremely strong
- Quick, silent and easy to use - 30 seconds to fix
- No assembly - the Professional comes in two main parts ready to use
- Light & compact - takes up less than 1 cubic ft of storage
- Supplied complete with high security lock



### Full fitting instructions

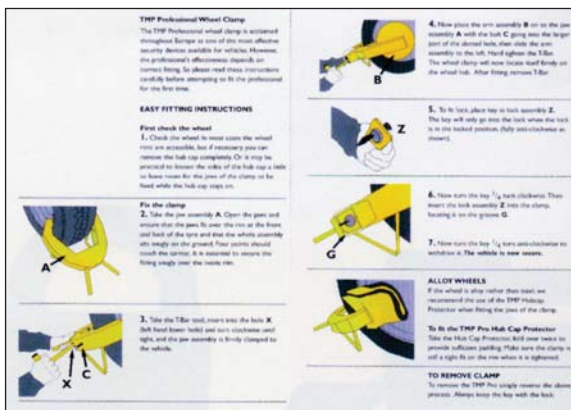

# W

ith a highly knowledgeable sales team available to assist with any project at any stage from design through implementation and to completion, and access to a wide range of production facilities, we are committed to providing the complete supply service to our customers.

Based in Berkshire at the heart of the motorway network of the M4, M40 and M25, Street Furnishings Ltd is ideally placed for rapid dispatch of goods from its well stocked warehouse to all parts of the United Kingdom and Ireland - from the Channel Islands to the north of Scotland and from East Anglia to the west of Ireland.

Contact the sales office to speak to people who understand the needs of governmental and local authorities as well as contractors. Or visit the web site for more details of our extensive product range.



Festival House • Mumbery Hill • Wargrave • Berkshire • RG10 8EE  
Tel: 01189 404717 • Fax: 01189 403216 • Email: [mail@streetfurnishings.co.uk](mailto:mail@streetfurnishings.co.uk)  
[www.streetfurnishings.co.uk](http://www.streetfurnishings.co.uk)

