

The History of Articulators: The Wonderful World of “Grinders,” Part III

Edgar N. Starcke, DDS, FACP¹ & Robert L. Engelmeier, DMD, MS, FACP²

¹Department of Restorative Dentistry and Prosthodontics, University of Texas HSC at Houston School of Dentistry, Houston, TX

²Department of Prosthodontics, University of Pittsburgh School of Dental Medicine, Pittsburgh, PA

Keywords

Articulator; denture grinder; denture milling machine.

Correspondence

Edgar N. Starcke, The University of Texas Health Science Center at Houston, School of Dentistry, 7500 Cambridge St., Houston, TX 77054. E-mail: Edgar.N.Starcke@uth.tmc.edu

The authors deny any conflicts of interest.

Accepted September 24, 2014

doi: 10.1111/jopr.12276

Abstract

This is the third article in a three-part series on the history of denture occlusal grinders. The first article reviewed the earliest attempts to “grind in” denture occlusion by hand manipulating simple articulators with special features to those more complex devices powered by hand cranks. The second article explored devices that were motor driven, either those with cast holders to grind the occlusion of processed dentures or those designed to utilize an articulator’s condylar or incisal controls for that purpose. This article examines those articulators that have a rotary occlusal grinder as an essential feature. Additionally, this article reviews those grinding devices produced as attachments for popular contemporary articulators.

This third article concludes the series on denture occlusal “grinders”^{1,2} by examining those articulators that incorporated a grinding device as a requisite feature. “Grinding” or “milling” devices, almost from the dawn of their conception and use, have not only captured the imaginations of dental scholars, but for some, have evoked frustration and anger as well.

The procedure for milling artificial teeth is placing an abrasive compound between the maxillary and mandibular teeth. Because the compound acts as a cutting tool while the opposing teeth are moving across each other, naturally both sets of teeth lose tooth stock. Since this factor is uncontrollable, some critics have condemned the milling process.³ B. B. McCollum stated, “Just how fatal to articulation the various “grinding” machines are we demonstrated on this [tooth wear testing] device.” He further commented, “Teeth cannot be rubbed together with a grinding powder or mixture between them without destroying ‘centric.’ So-called ‘freed centric’ is a poor makeshift in attempting to compensate for malarticulation.”⁴ McCollum’s sentiments are a common thread among critics of denture grinding devices. Furthermore, it is obvious from the patent letters and from descriptions in the literature that most inventors’ beliefs as to what the grinding process should achieve surely would have resulted in overgrinding the teeth.

A voice of reason

Milus M. House (Fig 1)⁵ was well aware of the folly of indiscriminate overgrinding of artificial teeth. “When the Rotary

Occlusal Grinder is used,” he said, “it will be found that it takes only a very slight grinding to [achieve] a freedom of occlusion and obtain a balance in all positions. It requires, however, that the teeth be properly articulated and that central occlusion is correct before grinding is attempted.”⁶ House believed that the “spot grinding” process should eliminate gross interferences in existing cases.³

In the early 1920s, Milus House and his associates at the Deaner Institute for Dental Research in Kansas City, Missouri, conducted a “series of tests, studies and observations of . . . natural teeth and movements of the mandible and . . . cases with complete dentures where cusps were present.”⁶ House reported this research revealed that in the natural dentition, a “horizontal freedom of movement in the central or triturating ranges of occlusion” was present in all cases to some degree. In contrast, “a large number of cases with complete dentures were tested and without exception where cusps were present, the occlusion was ‘locked’.”⁶ House considered complete denture occlusion to be “locked” if there were no horizontal lateral movements of 1 mm or more without interference of the cusps. He reported that further testing disclosed that “trituration of short ranges of movement from centric occlusion in mastication are circular in the plane of occlusion . . . and this is the principle of Nature’s scheme in the freedom of occlusion and the triturating or grinding efficiency in mastication.”⁶ With these conclusions in mind, House conducted extensive experiments to develop an instrument that would give this result in restorative dentistry.



Figure 1 Dr. Milus M. House (1879-1959).

The “Occlusal Grinding Device for Articulators,” as illustrated in the patent letter dated July 19, 1927, (Fig 2) was the culmination of this work.⁷ The House Rotary Grinder, with a three-gear drive mechanism, was designed specifically for the Gysi “Simplex” articulator.⁷ However, most models were designed for more than one make of articulator. For example, the grinder in Figures 3 and 4 with additional retaining screw holes (2, 2), was also designed for other articulators as well, in this instance, the Snow “New Century” and “Acme” and both models of the Kerr articulator. In addition, House grinders were made for the Gysi “Trubyte,” the Hanau “H” Series and Kinescope, the McCollum, Monson, Lentz, Hall “Automatic Anatomic” and Wadsworth articulators. House discovered that to use the grinder with articulators having upper members that should not be removed, special attachments would be required. For example, the grinder in Figure 5⁸ with a special attachment is shown in use on a Wadsworth articulator with a bench lathe as the external power source. Figures 6 and 7 provide two detail views of the special attachment (indicated by arrows) that secures the grinder to the horizontal condylar bar.

During the 1920s, one of the most productive collaborations at the Deane Institute was that of Milus House and John W. Needles. Their alliance produced a new mandibular registration system, also known as the “House-Needles Chew-in” procedure, the Needles-House incisal pin and guide and, of course, rotary occlusal grinders, three versions for which patents were received.^{7,9,10}

The patent letters did not provide precise measurements of the grinding movements of these devices, but indicated only that

July 19, 1927. M. M. HOUSE 1,636,304
 OCCLUSAL GRINDING DEVICE FOR ARTICULATORS
 Filed Nov. 16, 1925 2 Sheets-Sheet 1

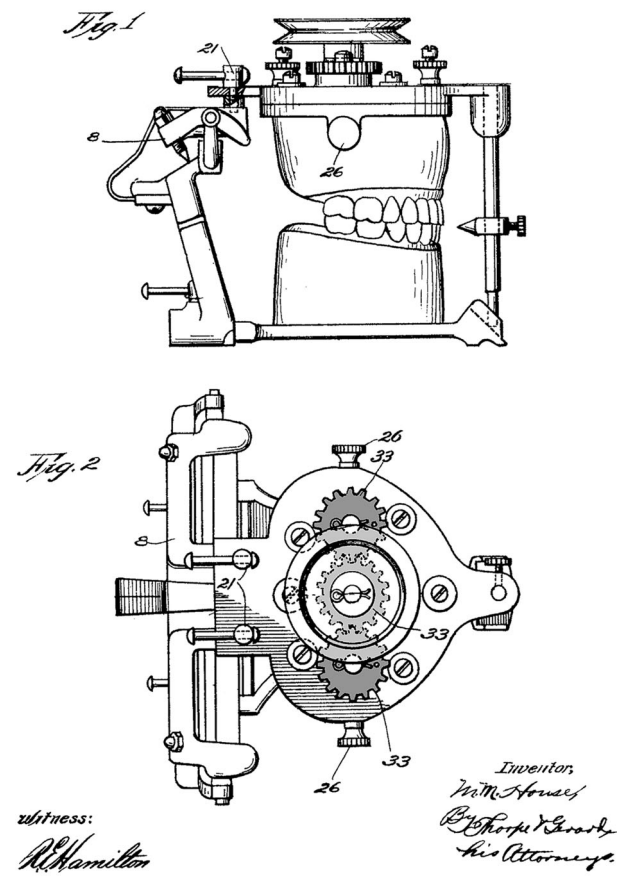

Figure 2 House “Occlusal Grinding Device for Articulators.”⁷ This model, designed specifically for the Gysi “Simplex,” to be mounted in lieu of the maxillary cast support by connecting it to the articulator frame (8) with screws (21). Retaining screws (26) hold the maxillary cast in place. This model was the first of three grinders^{7,9,10} to be patented in July and August of 1927. It was the only one with a three-gear drive mechanism.

they produced a “continuous unidirectional circular movement of small amplitude simulating a mortar and pestle action.”^{7,9} Sharry, however, stated that the grinder on the upper member of the House articulator “creates a free area, 20/1000-inch, at centric position.”¹¹ Of the three models patented, it is not surprising that House chose the one shown in Figure 2 to be incorporated into his own articulator (Figs 8–10).

An interesting recent discovery concerns a House Occlusal Grinder used in a novel way. The lower member of a Hanau Kinescope was replaced with a grinder mounted upside down (Figs 11 and 12). This altered Kinescope may be unique, although it is quite possible that others may exist. Nevertheless, it is obvious that much time and effort was given to this contrivance.



Figure 3 House "Occlusal Grinding Device for Articulators." Unlike the model illustrated in the patent letter, this model can be mounted on the Snow "New Century" and "Acme" and the Kerr articulators using the additional holes (2) for the retaining screws.

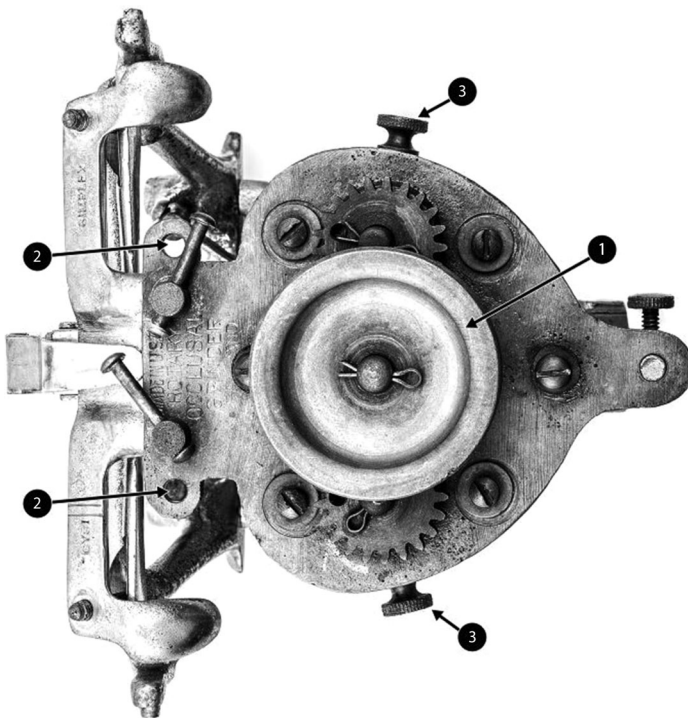

Figure 4 House "Occlusal Grinding Device for Articulators." This is a top view detail of the three-gear drive mechanism. The third gear is obscured beneath the pulley (1); however, both additional holes (2, 2) can be seen in this view. Note the two retaining screws (3, 3) used for securing the maxillary cast in place.

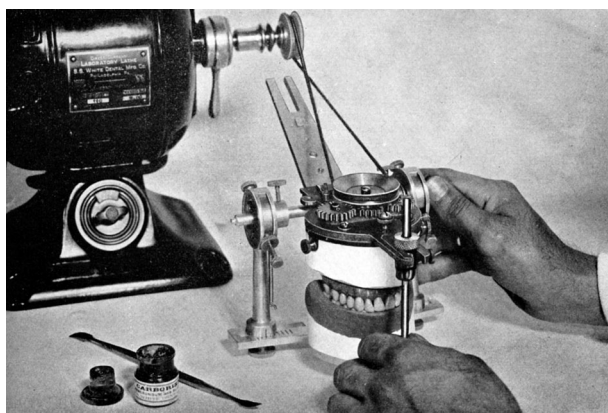

Figure 5 This photograph demonstrates the typical technique for use of the House Occlusal Grinder with a bench lathe as the external power source. A Wadsworth articulator is shown with the upper member rotated back in order to secure the House grinder in the proper position. A special attachment is required for articulators from which the upper member cannot be removed.⁸

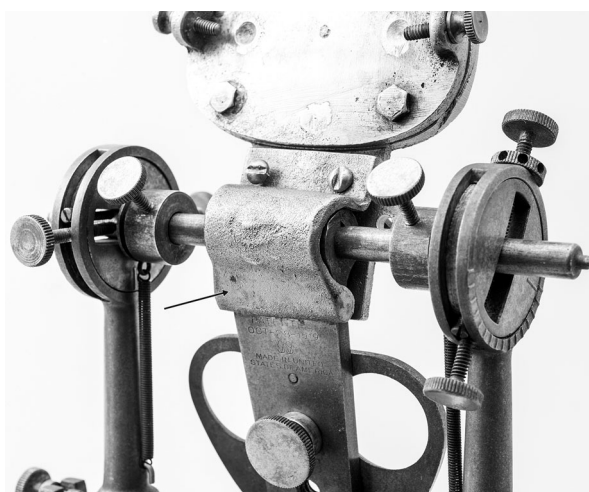

Figure 7 Detail of the Wadsworth articulator special attachment (arrow) secured to the upper member by two screws.



Figure 6 The Wadsworth articulator (1925) with the grinder in place. This is a posterior lateral view of the special attachment (arrow) used to secure the grinder to the horizontal condylar post.

The “Precision Coordinator” and the “Tripod”

The House Articulator, the “Precision Coordinator,” produced by W. E. Van Dorn and W. H. Terrell, and the “Tripod,” produced by C. J. Stansbery are the articulators incorporating a rotary occlusal grinder that are likely most familiar to the profession. Each of these grinders (Fig 5) was also intended for use with a bench lathe as an external belt drive power source. There are differences, however, in location and operation of the grinders. The House occlusal grinder controls the maxillary cast holder while the “Tripod” and “Precision Coordinator” grinders control the mandibular cast holders. Furthermore,



Figure 8 The House Articulator (1927). The occlusal grinder’s mechanical components were sealed in a metal casing for protection and lubrication.

while the House occlusal grinder has one setting (20/1000 inch),^{11,12} the “Precision Coordinator” occlusal grinder (Fig 13) is adjustable from 0 to 10, 20, 30, and 40/1000 inch; Fig 14).^{11,13} The “Tripod” (Fig 15) grinding apparatus is not adjustable but is complex, generating a protrusive movement that is a constant 40/1000 inch and lateral movement that is variable (0 in the condylar region, 20/1000 inch in the molar region and 40/1000 inch in the incisal region).^{12,14} This variable grinding action is achieved by the movement of the milling plate (1) (supporting the cast holder) secured to the base (2) anteriorly to the grinding pulley (3) and posteriorly to the base with a setscrew (4) deposited vertically through a slot that allows only “forward-backward” movement. The belt guard (3a) has been removed in order to view the pulley. Figure 16 is a graphic depiction of Stansbery’s concept of the milling operation.¹⁴

At the anterior underside of the plate within the grinding pulley (3), a 5/16-inch pin extends downward through a



Figure 9 A top view detail of the House occlusal grinder showing the pulley and metal casing. Even though House received patents on his grinding devices, he did not patent any of his articulators.³

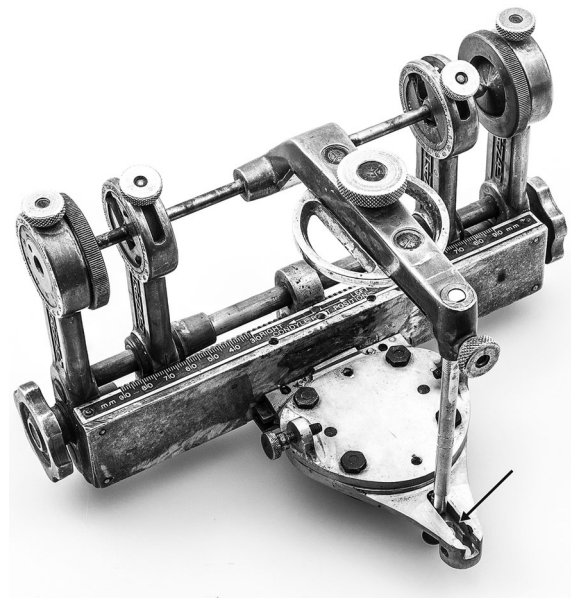

Figure 11 A "bird's eye" view of a Hanau Kinescope articulator with the lower member having been replaced with an occlusal grinder that House designed for large articulators. For obvious reasons, the grinder has been attached upside down, and a slot (arrow) has been cut into the incisal plate to establish the correct vertical distance between the upper and lower members and to provide clearance for movements of the incisal pin.

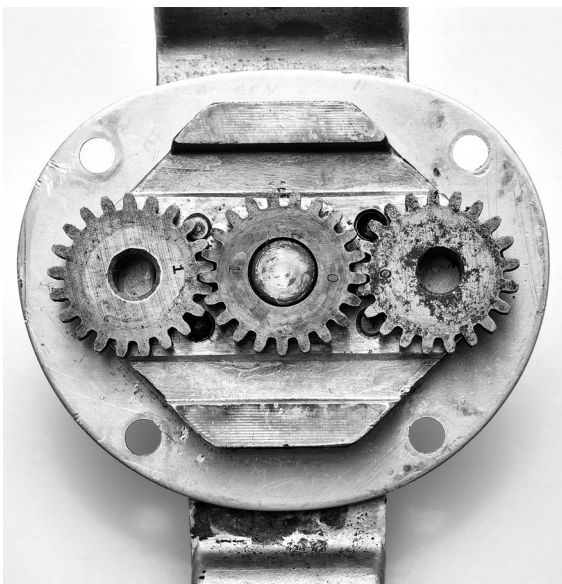

Figure 10 Top view detail of the three-gear drive mechanism of the occlusal grinder with the casing removed.

1/2-inch ring bearing in the base (2) (Fig 17). During the use of the "Tripod" for the construction of dentures, a sleeve holds the pin in the centric position. In the milling operation, the sleeve is removed and replaced by an eccentric pulley, the inner bearing of which is 20/1000 inch off-center. The combination of a lathe moving the anterior pulley and the "forward-backward" movements at the posterior produces the grinding movements created by Stansbery. Two idler pulleys (5, 5) are used to guide the engine belt around the posterior control.¹⁴

Notably, Stansbery as well as Van Dorn and Terrill produced articulators prior to the commercial models discussed above.

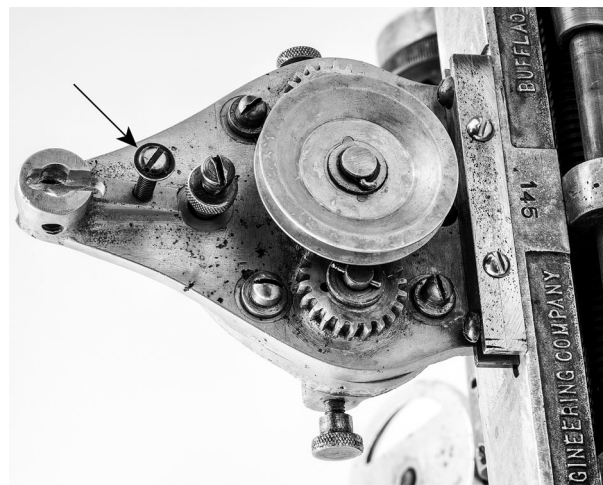

Figure 12 A close-up view of the occlusal grinder from below the Kinescope. An adjustable screw (arrow) has been added to the incisal plate for leveling and anterior support of the articulator.

The Stansbery "Dental Orient," (c. late 1920s) (Figs 18 and 19) with likely 50 or fewer manufactured, had a grinder similar to that of the "Tripod," while the grinder on the prepatent model of the "Precision Coordinator" was not adjustable (Figs 20 and 21). The incisal guide (Fig 22) included a puzzling feature: a removable protrusive channel (2) in which the incisal pin (1) rests while in centric position. When secured in place, this device would not allow lateral movements.

Figure 13 The Terrell "Precision Coordinator." The pulley (1) for the occlusal grinder is located on the left side of the lower member extending past the edge of the base. This pulley controls the speed of the movements of the milling plate (2). The milling plate also functions as the cast holder and can be removed from the base (3).



Figure 14 This view beneath the lower base (3) of the Terrell "Precision Coordinator" reveals that the grinder pulley (1) has four amplitude settings for the grinding motion: 10, 20, 30, and 40/1000 inch, with 0 indicating the centric position. Loosening the two screws (4, 4) on the numerical plate (5) and rotating the plate adjusts the pulley to the desired amplitude setting.

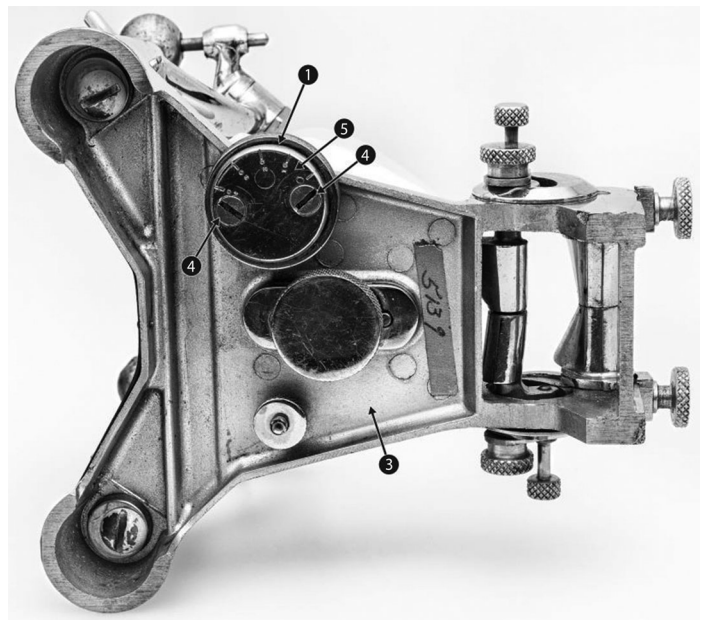



Figure 15 Side view of the Stansbery "Tripod." The maxillary and mandibular casts are mounted with Stansbery's extraoral tracer. Note that there are two anterior controls (A & B), through which the extraoral tracer extends, and one control (C) centered posteriorly. The upper member is in the shape of a "T," while the lower controls form a triangle.

Obscure but noteworthy

On November 17, 1936, Leslie N. Roebuck of Melbourne, Victoria, Australia, received a patent¹⁵ for an articulator he described as being uncomplicated and inexpensive with a rotary grinder on the upper member, "... whereby the [artificial] teeth may be ground [so] that the possibility of the teeth being locked in use is reduced to a minimum."¹⁵ The articulator was constructed according to the concepts of Bonwill's

triangle and Monson's spherical theory of occlusion. The incisal guide was adjustable; however, the condylar guides were fixed and coincidental with a mounting template having a curvature corresponding to a 9.5-inch sphere.¹⁶

Although there were examples of the 1936 patent model produced, the 1938 patent model¹⁷ was promoted for commercial use (Fig 23).¹⁸ There were no significant differences in the two articulators except for structural improvements and the addition of a "loading weight" to the incisal pin.¹⁷ The principal

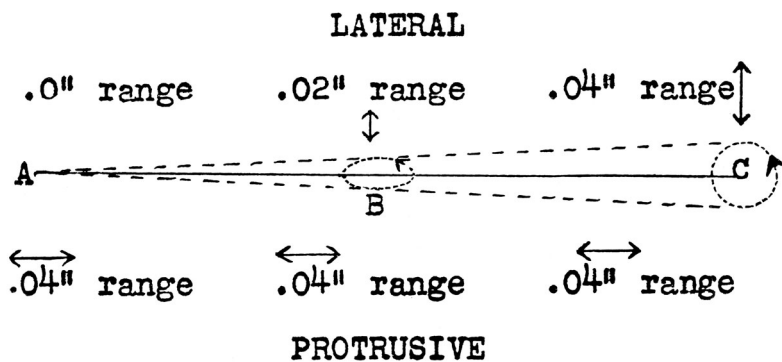

Fig. 60—The points A, B, and C that lie on the median line in condyle, molar and incisive regions, respectively, while the central sleeve is in place, move in paths as indicated when actuated by the eccentric pulley. It will be noted that the protrusive range is constant while the lateral range is variable, increasing from zero in the condyle region to a millimeter in the incisal. This should be recognized as a condition similar to the horizontal movement of the mandible.

Figure 16 Stansbery's diagram of the milling action of his occlusal grinder. Note that there is a constant protrusive movement of 0.04 inch (A) while the lateral movement ranges from 0.0 inch (A) to 0.02 (B) to 0.04 inch (C) forward to the incisal base.¹⁴

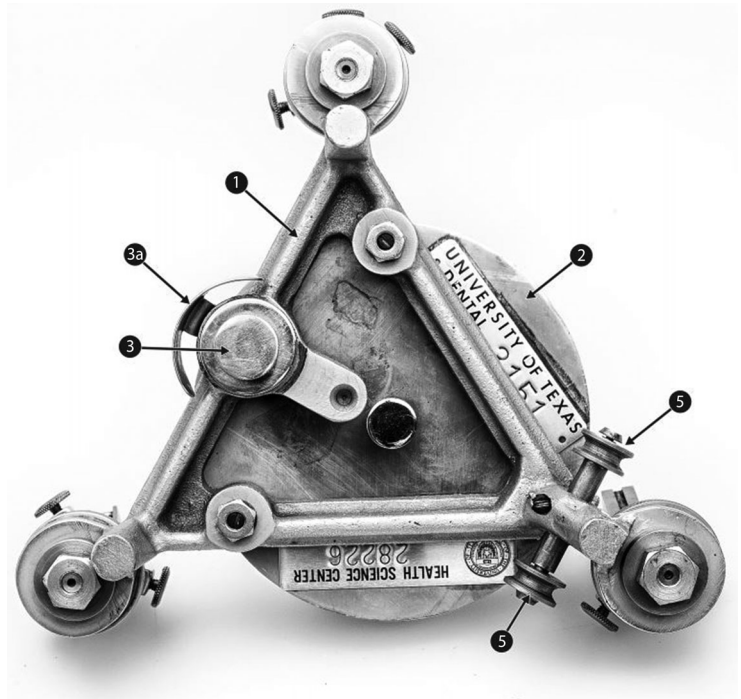

Figure 17 This view beneath the lower member of the “Tripod” displays its triangular construction. The pulley for the occlusal grinder (3) is centered between the anterior controls, while two idler pulleys (5, 5) guide the engine belt around the posterior control. Note that the grinder belt guard (3a) is in position on the articulator.

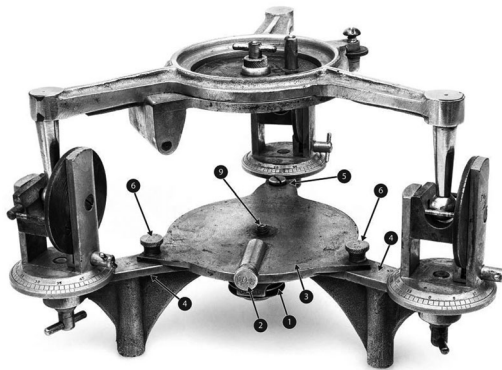

Figure 18 The Stansbery “Dental Orient.” Looking through the two anterior controls, the grinder pulley (1) can be seen with the locking screw (2) within a raised channel directly above it on the surface of the milling plate (3) mounted on the lower articulator base (4, 4). With the milling plate secured in the posterior by a screw (5) in a slot with a protrusive orientation and the anterior set screws (6, 6) in holes that allow lateral movement, the grinding action is essentially the same as in the “Tripod.” A retaining screw (9) for the mounting ring is located in the center of the milling plate.

differences were in the rotary grinders. While both grinders produced eccentric movements of low amplitude, the 1936 model grinder (Fig 24) had a rear guide pin (46a) bearing against a guide slot (46b) of the oscillating plate (38) producing, “. . . a greater grinding movement to the incisors.” The guide slot produced only a protrusive movement while the guide pins (46, 47) allowed lateral movement (patent Fig 3).

Roebuck may have “borrowed” this idea from Stansbery because the functional designs are so remarkably similar (patent

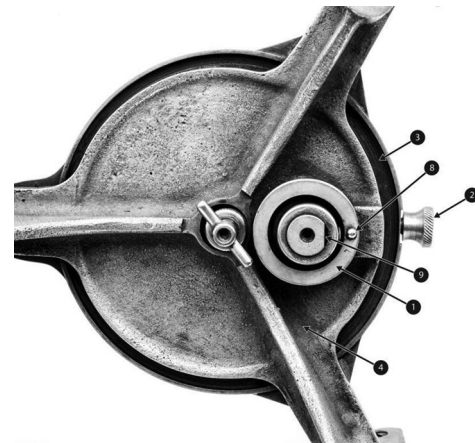

Figure 19 The Stansbery “Dental Orient.” View of the grinder pulley assembly underneath the articulator lower base (4). When the bead (8) on the pulley (1) is centered on the flat surface (9) of the inner plate and is in line with the lock screw (2), the milling plate (3) is in centric position.

Fig 7); however, in the 1938 model, this feature was eliminated. He described the new rotary grinder as one that permitted, “. . . the carrier to be rotated bodily, with a substantially circular motion.”¹⁷

On May 15, 1928, William M. Gambill of Merkel, Texas, received a patent¹⁹ for an articulator with a rotary grinder; however, this grinder is uniquely different from those that have been previously examined and one with which the profession is generally unfamiliar. It is apparent that Gambill was influenced by the Hanau “H” series condylar controls (Fig 25). The singular distinction of this articulator, however, was the incisal



Figure 20 The prepatent model of the Terrell "Precision Coordinator." This view is to demonstrate the differences between the prepatent and commercial models. There are obvious similarities, but the workmanship and the materials used reflect what would perhaps be expected in a prototype.

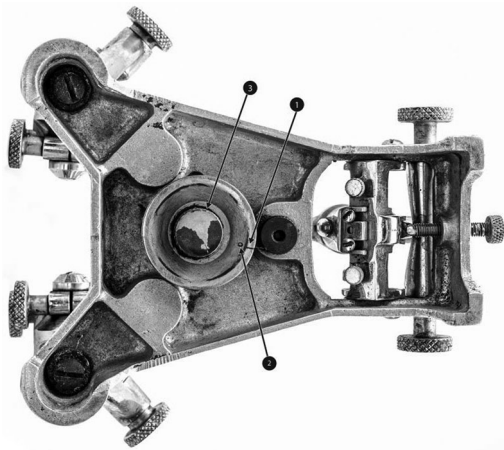

Figure 21 The prepatent model of the Terrell "Precision Coordinator": view of the grinder pulley. The occlusal grinder is not adjustable. The only markings are a *dash* on the outer rim (1) of the pulley and a *circle* on the inner bearing plate (2). When these marks are aligned and centered anteriorly, the cast holder is in centric position during pregrinding procedures. The locking (3) member controls the movement of the pulley.

pin and guide, designed to control the movements of the upper member of the articulator during the milling process (Figs 26 and 27).

As illustrated in the patent letter (Fig 28),¹⁹ the mechanism that rotates the incisal pin is located entirely within the upper member of the articulator. The rigid operating shaft (57; patent Fig 2) extends from a point (55) at the rear (where it exits coupled to a flexible cable [59]) to the anterior section. The

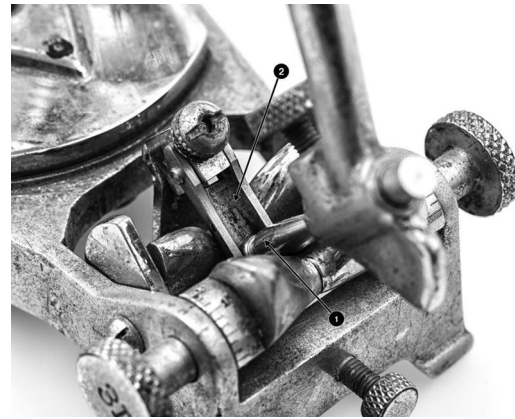
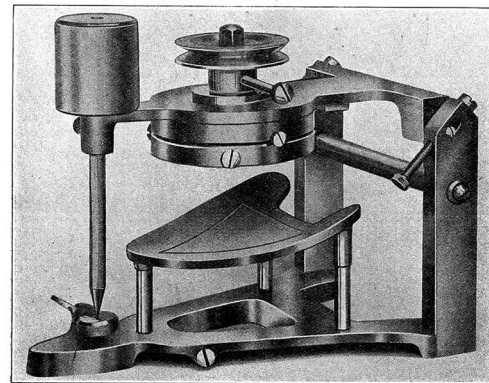

Figure 22 Detail of the Terrell prepatent model incisal pin and guide. Of interest is a feature of the incisal controls that was not included in the patent. The lower end of the incisal pin (1) rests in a restrictive channel (2) when the articulator is in centric position. The function of this channel is unclear. It may have been a centric lock and/or intended to ensure a straight protrusive path. Nevertheless, it would have been removed for the articulator to function properly.

ADVERTISEMENTS

The "ROEBUCK" OCCLUSION TECHNIQUE
 Patent Nos. 424684-33756/35.



THE "ROEBUCK"
 IS A COMPLETE COMBINATION OF AN ANATOMICAL
 ARTICULATOR & AUTOMATIC OCCLUSION GRINDER
**Proclaimed by the Profession as the
 most notable contribution to DENTAL
 PROSTHESIS in recent years**
Its Principal Attribute is Absolute Simplicity
 PERFECT ARTICULATION AND ACCURATE OCCLUSION
**ASK TO SEE IT DEMONSTRATED AT THIS
 ESTABLISHMENT AT ANY TIME ON ANY DAY!**
 A TECHNIQUE BOOKLET WILL BE FORWARDED ON APPLICATION.

Manufacturers and Distributors:
COTTRELL & CO.
 15-17 CHARLOTTE STREET LONDON. W.I.

Figure 23 An advertisement for the "Roebuck" articulator with an offer by Cottrell & Co. to demonstrate the occlusion technique "at any time on any day." Cottrell & Co., the manufacturer and distributor, noted that the "Roebuck" was "Proclaimed by the profession as the most notable contribution to dental prosthesis in recent years."¹⁸

Nov. 17, 1936. L. N. ROEBUCK 2,061,484
 APPARATUS FOR USE IN THE FORMATION OF ARTIFICIAL DENTURES
 Filed Oct. 11, 1933

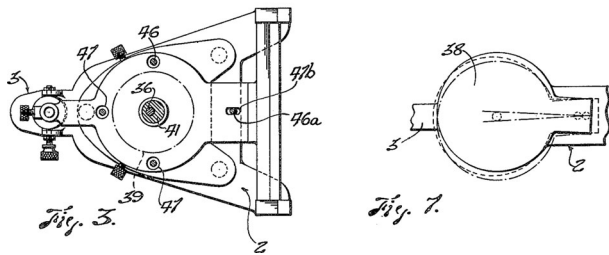

Figure 24 L.N. Roebuck, US Patent No. 2,061,484; November 17, 1936.¹⁵ Patent Figure 3 illustrates the relationship of the grinder pulley (39) and the offset “vertical spindle” (36) and “bearing” (41) on which it moves to the guide pins (46, 47) and posterior guide pin and slot (46a, b) of the oscillating plate (38). Patent Figure 7 is a “plan view” showing the approximate positions of the oscillating plate (38) during a rotary grinding operation and its relationship to the upper anterior frame member (3) and posterior frame member (2).

anterior section is provided with a vertical opening for the incisal pin (66) to which a worm gear (65) is fixed. The worm gear engages a worm pinion (58) attached to the operating shaft. When the flexible end (59) of the operating shaft is provided with a power source, such as a handpiece, the action rotates the incisal pin in a purely circular motion.

So, how was the grinding motion produced? According to Gambill’s patent letter,¹⁹ the incisal pin had a “detachable incisal point member (72) . . . that is disposed at right angles with respect thereto as well as positioned to one side of the axis of the shaft” (66).¹⁹

“The incisal guide was a horizontal V-shaped trough (73) . . . that was closed at the forward end with an adjustable screw (80) to adjust the protrusive movements [as well as to stabilize the pin in centric position].”¹⁹ In centric position

the horizontal incisal point (72) faced forward (patent Figs 6 and 9).

It should be noted that the patent description of the incisal pin was not consistent with several articulators available to the authors. Typically, the right angle point unit was soldered to and centered on the incisal pin. Figure 26 shows the incisal horizontal point unit (7b) in centric position engaging the adjustable screw (8) that controls centric position, and Figure 27 shows the incisal horizontal point unit (7b) engaging both walls (8) of the V-shaped trough as the incisal pin rotates. Gambill claimed that the movements of the right angle “point unit” engaging the inclined walls of the “guide unit” produced the oscillatory and vertical movements of the upper member of the articulator required for the milling process;¹⁹ however, these movements have been observed to be extreme, and it is doubtful that this grinding process would have produced the desired effect.

During the same time period that Milus House received three occlusal grinder patents (mid- to late-1920s), William Gambill created attachments based on his original incisal pin and guide grinder patent for three popular articulators of the day.¹⁹ On February 28, 1928, he received an attachment patent²⁰ for the Gysi “Simplex” (Fig 29), the Wadsworth articulator (Fig 30), and the Hanau “H” articulators (Fig 31). By utilizing existing structures of these articulators, that is, sleeves, holes, and slots, Gambill designed removable versions of his original grinder design with “coupling” extensions for substituting his incisal pin and guide for each articulator’s original ones. Each Gambill rotary incisal pin assembly had a chamber to house the worm gear and worm pinion. Attached to the worm pinion was a flexible drive shaft connected to the power source. The chamber had a central vertical sleeve that held the rotating incisal pin. The incisal pin assemblies as well as the incisal guides, using the “coupling” extensions, were secured to the articulators by either bolts or screws.²⁰

In the patent letter, Gambill claimed that, “. . . it is to be understood that a dental articulator attachment, in accordance with this invention can be employed with any form of

Figure 25 The Gambill Articulator, 1928. The grinding apparatus notwithstanding, this articulator may have been more competitive on the market if Gambill had chosen higher grade materials for its construction; however, there is no evidence to suggest that he made any improvements in that regard. A ridged shaft (1) is located within the upper member (2) extending forward to (3) where it is connected to the worm-gear and pinion system that rotates the incisal pin (4). Posteriorly, the ridged shaft is attached to a long flexible shaft (spring) (5) from which extends a large diameter copper wire (6). The power source was most likely a belt driven, variable speed handpiece. The tip of the incisal pin had vertical (7a) and horizontal (7b) units that engaged the horizontal V-shaped incisal guide (8). Incisal screw (9) and condylar screws (10) established centric position.



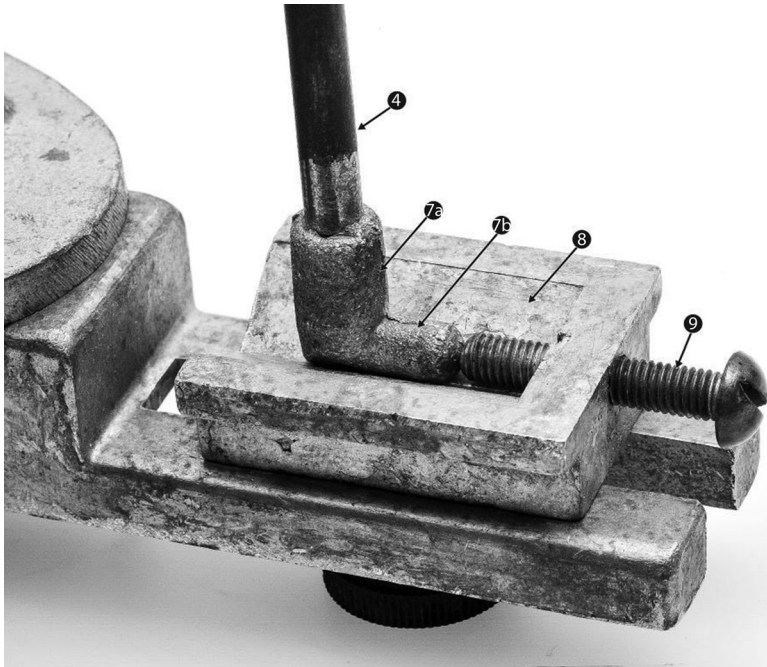

Figure 26 The Gambill Articulator, 1928. This detail of the incisal pin and guide illustrates the relationship of the horizontal tip unit (7b) of the incisal pin (4) to the V-shaped incisal guide (8) and to set screw (9) when the articulator is in centric position; 7a is the vertical tip unit of the incisal pin that secures the horizontal top to the shaft (4). Contrary to the claims made in the patent letter,¹⁹ the incisal pin tip is not removable.

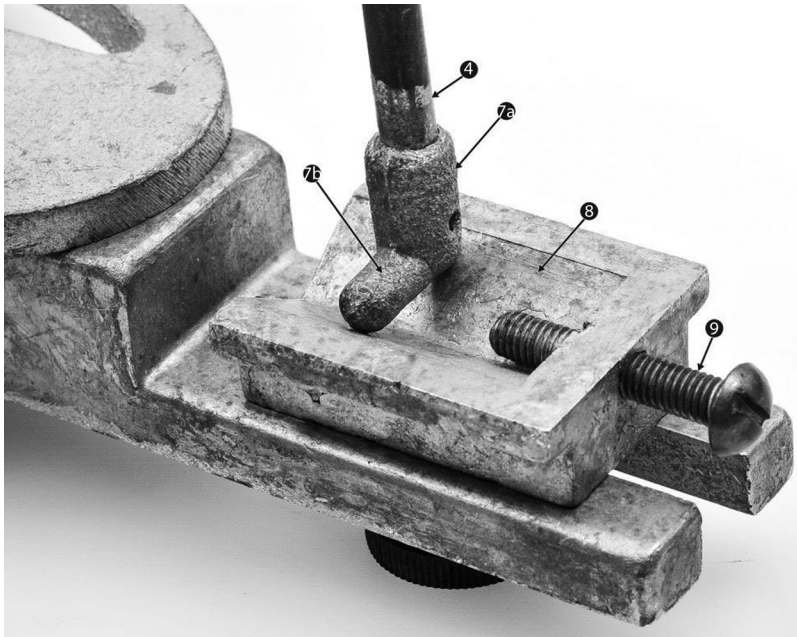

Figure 27 The Gambill Articulator, 1928. This detail of the incisal pin and guide shows a one-quarter turn of the pin (7a & b) during the grinding operation. This suggests that during a full rotation, there would primarily be exaggerated lateral and vertical movements. Under these conditions, however, some oscillatory movement would probably be achieved as well.

May 15, 1928.

W. M. GAMBILL
ARTICULATOR

1,669,462

Filed Nov. 29, 1926 3 Sheets-Sheet 2

Fig. 2.

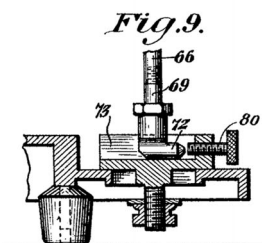
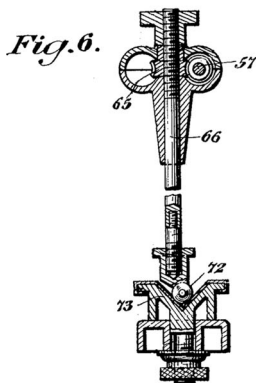
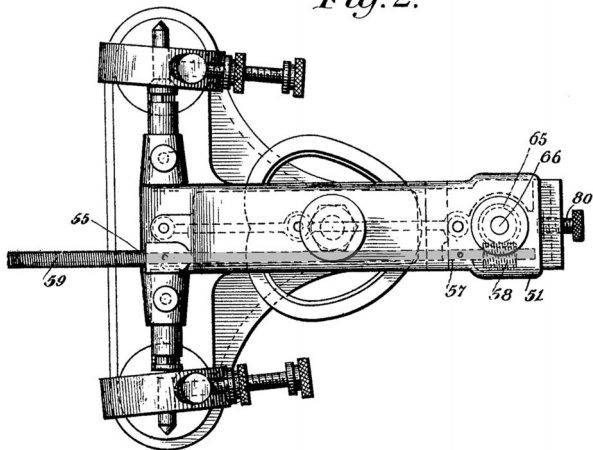

INVENTOR.
William M. Gambill,
BY *Geat. Kimmel,*
ATTORNEY.

Figure 28 The Gambill Articulator, 1928.¹⁹ Patent Figures 2, 6, and 9 are sectional views of the incisal pin and guide occlusal grinder power train as described in the text.

dental articulator for which it is found applicable. . . .²⁰ Gambill obviously had high expectations for his grinder attachments, but it is more likely that competition with M. M. House would have put a premature end to this venture.

The account of House's development of occlusal grinders for many of the popular articulators of the day as well as for his own articulator is, undoubtedly, a lesson in marketing. Having an international reputation as a clinician, educator, author, and innovator, House clearly enjoyed some measure of success for his efforts.

Mandible: the final frontier

Perhaps the most curious approach to "grinding" or "milling" artificial teeth came to the attention of the profession with the introduction of the Warwec "Equilibrator" in 1960. This device was created to generate vibration of the human mandible for the refinement of complete denture occlusion in the mouth. W. Ross Stromberg, of Orlando, Florida, presented the "Equilibrator" at the annual session of the Academy of Denture Prosthetics in San

Feb. 28, 1928.

W. M. GAMBILL
ATTACHMENT FOR DENTAL ARTICULATORS

1,661,119

Filed Oct. 4, 1926 3 Sheets-Sheet 1

Fig. 1.

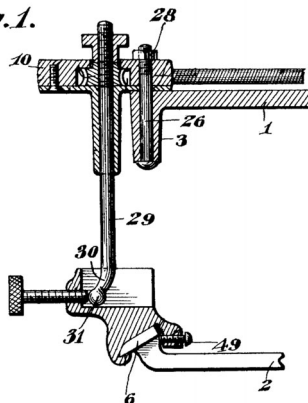

Fig. 3.

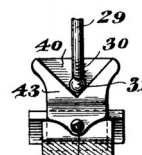

Figure 29 W. M. Gambill's grinder attachment "for an articulator of the Gysi type."²⁰ Patent Figures 1 and 3 illustrate how the Gambill grinder attachments are secured to the Gysi "Simplex" articulator. The vertical sleeve (3) for the "Simplex" incisal pin was used to attach the housing (10) for the Gambill "grinding shaft" (incisal pin) (29) and associated worm gear and pinion to the upper member (1). A nut and bolt (28, 26) was used to secure the grinding assembly in place. The tip of the "grinding shaft" is slightly curved at (30) and terminates at (31) with a spherical shape. "The coupling" extension (43) for the V-shaped horizontal incisal guide (40) was designed to slide over the original Gysi incisal guide (6) of the lower member (2) and to be secured in place with screw (49).

Juan, Puerto Rico.²¹ Stating that there was a need for "a simple yet accurate method for refinement of the occlusion beyond that accomplished by usual methods," Stromberg proposed that a method of vibration of the mandible offered possibilities for this purpose.²¹ He described the "Equilibrator" as a handheld, chin rest vibrator with two speeds, having high frequency-small amplitude straight vertical movement (Fig 32). Stromberg emphasized that vibration grinding must be limited to *refinement grinding*, and only after all other occlusal corrections are made using customary accepted procedures. "The objective," he said, "is to vibrate the mandible along the physiologic arc of closure in centric relation" . . . to bring the teeth into light intermittent contact in centric occlusion.²¹ Naturally, this was the same objective for occlusal contacts in movements toward protrusive and right and left lateral positions. Stromberg explained that the patient was cautioned "only a light tooth contact is needed and that contact will only be made *as the dentist presses against the chin*, causing the teeth to vibrate against each other" (Fig 33). The pressure is applied for approximately 3 minutes in centric occlusion and approximately 2 minutes in the other positions.²¹

Unfortunately, this places patients in "uncharted territory": most patients are not prepared to make the subjective decisions required of them; that is, assessing the quality and quantity of occlusal contacts while attempting to control unstable denture bases due to the influences of vibratory forces and a coarse pumice or carborundum paste between the maxillary

Feb. 28, 1928.

1,661,119

W. M. GAMBILL
ATTACHMENT FOR DENTAL ARTICULATORS
Filed Oct. 4, 1926 3 Sheets-Sheet 2

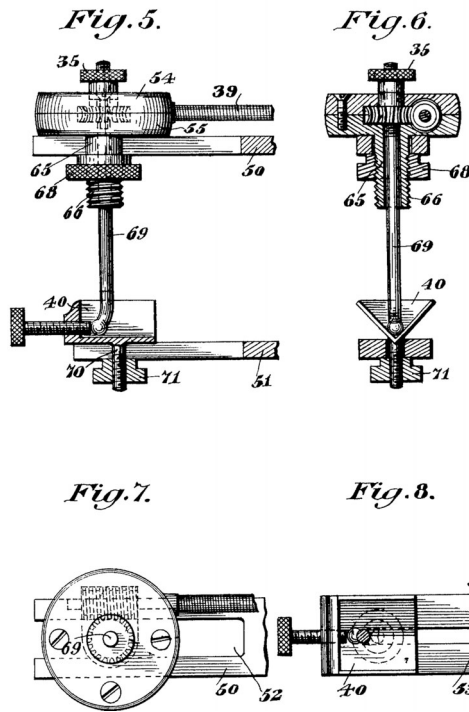

Feb. 28, 1928.

1,661,119

W. M. GAMBILL
ATTACHMENT FOR DENTAL ARTICULATORS
Filed Oct. 4, 1926 3 Sheets-Sheet 3

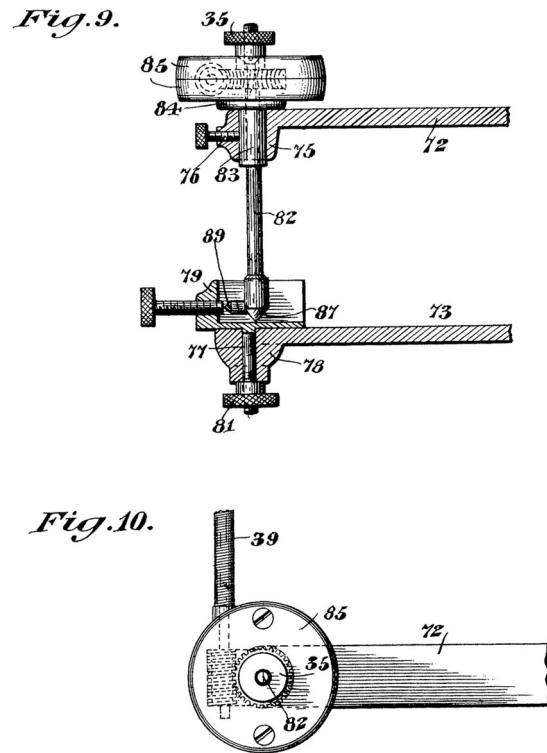

Figure 30 W. M. Gambill's attachment "for an articulator of the Wadsworth type."²⁰ Patent Figures 5 to 8 illustrate how the Gambill grinder attachments are secured to the Wadsworth Articulator. The upper (50) and lower (51) members of the Wadsworth articulator had slots (52) and (53), respectively, where the original incisal pin and guide were attached. The housing (54, 55) for the grinding mechanism and associated flexible drive shaft (39) was secured to the upper member by inserting the tubular sleeve (65) into the slot through the open outer end and by tightening the lock nut (68) on the threaded lower end (66) of the sleeve. The "revolving shaft" (incisal pin) (69) could then move freely within the tubular sleeve or could be locked in centric position by tightening the nut (35) on top of the housing (54, 55). The horizontal V-shaped trough (incisal guide; 40) was attached to the lower member by a threaded cylindrical vertical bar (70) that extended through the slot and secured with a lock nut (71).

Figure 31 W. M. Gambill's grinder attachment "for an articulator of the Hanau type."²⁰ Patent Figures 9 and 10 illustrate how the Gambill grinder attachments are secured to the Hanau H model articulators. The upper member (72) and lower member (73) have vertical collars (75, 78) with openings for the revolving incisal pin (82) and for the V-shaped incisal trough (79), respectively. The housing (85) for the gear system and rotating incisal shaft has a sleeve (83) with an annulus flange (84) that extends through the opening and is secured by a binding screw (76). The movement of the incisal rod is controlled by lock nut (35). It should be noted that the flexible drive shaft (39) was set 90° to the upper bow (72; patent Fig 10), and similarly, the incisal rod tip (89) at (87) was set at 90° to the revolving shaft (82), as it was in Gambill's original articulator patent. The incisal trough threaded coupling extension rod (77) was secured by lock nut (81).



Figure 32 The Warwec “Equilibrator,” W. Ross Stromberg, 1960. This device was introduced to the profession as a means to generate vibration of the mandible to refine complete denture occlusion in the mouth.

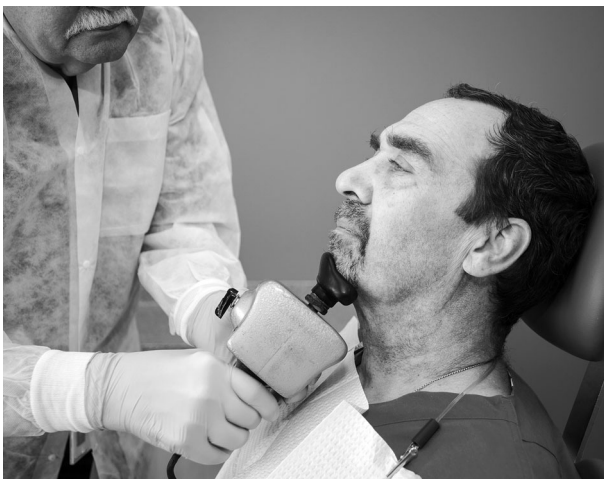

Figure 33 This is a demonstration of the suggested chin rest position for the use of the Warwec “Equilibrator.” This device produced only high frequency-small amplitude straight vertical movement.²¹

and mandibular occlusal surfaces. Under these conditions, predictable success would be extraordinarily difficult to achieve.

Acknowledgments

Photography and artwork by Brian Schnupp. The authors wish to acknowledge Mr. Schnupp’s excellent and important contribution.

References

1. Starcke EN, Engelmeier RL: The history of articulators: the wonderful world of Grinders, Part I. *J Prosthodont* 2006;15:1-13
2. Starcke EN, Engelmeier RL: The history of articulators: the wonderful world of Grinders, Part II. *J Prosthodont* 2012;21:232-252
3. House JE: The design and use of dental articulators in the United States from 1840–1970. Master’s thesis, Indiana School of Dentistry, Indianapolis, IN, 1970, pp. 227, 265-269, 331-364
4. McCollum BB and Stuart CE (eds): A research report. Scientific Press, South Pasadena, CA, 1955, p. 83
5. House JE: A dream fulfilled: the M.M. House memorial museum, *Alumni Bulletin*, Indiana University School of Dentistry 1972;51,4-11
6. House MM: Observations and studies of occlusion. *J Amer Dent Lab Assoc* 1926;1:17-21
7. House MM: Occlusal grinding device for articulators, US Patent No. 1,636,304, July 19, 1927
8. Nichols IG (ed): *Prosthetic dentistry*. St. Louis, Mosby, 1930, p. 249
9. Needles JW: Dental grinding device and process. US Patent No. 1,636,321, July 19, 1927 (Assignor of one-half to Milus M. House)
10. House MM: Dental triturating appliance. US Patent No. 1,637,569, August 2, 1927
11. Sharry JJ (ed): *Complete denture prosthodontics* (ed 2). McGraw-Hill, New York, 1968, pp. 212-219
12. Mitchell DL, Wilkie ND: Articulators through the years. Part I. Up to 1940. *J Prosthet Dent* 1978;39:330-338
13. Van Dorn WE, Terrell WH: Articulator. US Patent No. 2,119,896, June 7, 1938
14. Stansbery CJ: A complete denture technique: Part VI. The adjustment of the tripod. *Dent Digest* 1933;39:339-343
15. Roebuck LN: Apparatus for the use in artificial dentures. US Patent No. 2,061,484, November 17, 1936
16. Roebuck LN: Articulation simplified. *Proc 8th Australian Dent Cong* 1933;8:290-301
17. Roebuck LN, Everett SJ: Mechanism for grinding artificial dentures. US Patent No. 2,106,125, January 18, 1938
18. Advertisement: The “Roebuck” occlusion technique. [*The Mouth Mirror*. 1936;16, (no page number)]
19. Gambill WM: Articulator. US Patent No. 1,669,462, May 15, 1928
20. Gambill WM: Attachment for dental articulators. US Patent No. 1,661,119, February 28, 1928
21. Stromberg WR: Use of vibration in the occlusal refinement of complete dentures. *J Prosthet Dent* 1961;11:621-624