

The improved and complete
Instruction Manual

**for Installing TurnaSure[®]
DIRECT TENSION INDICATORS
(BS 7644)**

with

**HIGH STRENGTH FRICTION GRIP
BOLTS (BS 4395 Part 1 and Part 2)**



TurnaSure LLC

TABLE OF CONTENTS

| | |
|--|----|
| Introduction | 1 |
| Theory of High Strength Friction Grip Bolting..... | 2 |
| Direct Tension Indicators (DTIs)..... | 3 |
| Bolt Tensioning Using Self Colour DTIs..... | 6 |
| Bolt Tensioning Using Coated DTIs | 9 |
| Recommended Bolt Installation Procedure..... | 12 |
| Problems Commonly Encountered When Tensioning Bolts | 14 |
| Tool Selection and Performance | 15 |
| Checking for Specification Conformance..... | 16 |
| DTI Identification Markings | 19 |



TurnaSure LLC

(July 2006 edition)

International Headquarters
340 E. Maple Avenue, Suite 305
Langhorne, PA 19047

Phone: 215-750-1300
Fax: 215-750-6300
Website: www.turnasure.com

INTRODUCTION

High Strength Friction Grip (HSFG) bolts are well established as economical and efficient devices for connecting structural steel. The basic rules for their use are laid out in BS 4604 and BS 5950, by The Steel Construction Institute (SCI) and the British Constructional Steelwork Association (BCSA), and the developing European Structural Standards. Designers and inspectors are thoroughly familiar with these relevant specifications.

Since they originated in 1962, Load Indicator Washers, now commonly known as Direct Tension Indicators (DTIs), have been recognized by many engineers as the most reliable method for ensuring correct installation of HSFG bolts. TurnaSure LLC now introduces a new and improved DTI design, the TurnaSure® DTI, which equals and substantially exceeds the requirements of BS 7644. This new DTI has increased the popularity of DTIs in America where applications include bridges in most states, the world's tallest buildings, stadiums, refineries and other industrial and military structures.

This manual is written for Engineers, Supervisors, Inspectors and Erection Staff, to assist them in the proper installation of HSFG bolts using these new and improved DTIs. This will ensure that bolts have been tensioned to the values required in friction grip connections. The handbook discusses the theory of friction grip connections, proper installation of DTIs, general rules for bolt installation, problems typically encountered when installing HSFG bolts and many other subjects relative to HSFG bolting.

TurnaSure LLC has decades of DTI manufacturing experience and provides a range of consultation activity including seminars, site visits, tool recommendations, and specification commentary.

THEORY OF HIGH STRENGTH FRICTION GRIP BOLTING

The principle of HSFG bolted connections relies upon tensioning each bolt in the connection to a specified minimum tension so that the desired clamping force will be induced in the connection interface. Shear loads are then transferred by frictional resistance at the joint interface rather than by bearing on the bolt shanks and hole faces. In this type of connection there will be no movement of the connected materials when the connection is subjected to these loads. Movement in many types of joints is highly undesirable, hence the development of the friction grip connection. (Figure 1)

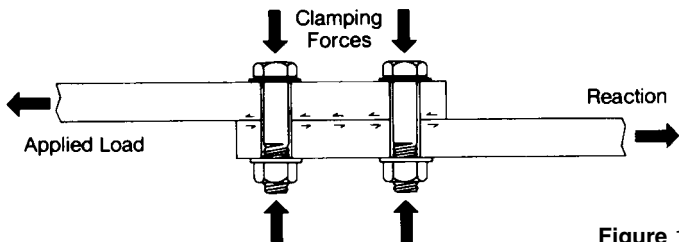

Figure 1

When tension loads are applied in the direction of the bolt axis, tensioning to a specified minimum tension is also important, particularly if the loads are cyclical and could induce loosening or fatigue failure of the bolts. The clamping force at the specified minimum tension should be greater than the applied loads. This will prevent the plies from separating or the bolts from developing any significant increase in tension stress over the installed pretension stress. (Figure 2)

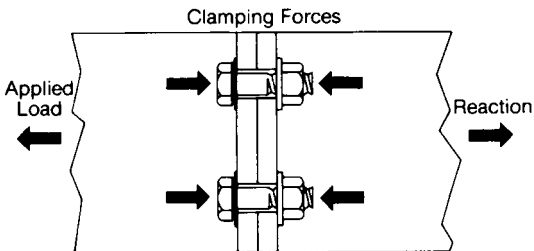

Figure 2

DIRECT TENSION INDICATORS (DTIs)

Only TurnaSure® Direct Tension Indicators (DTIs) are covered under British, American, and other worldwide patents. They are even more accurate than earlier designs, and are very simple devices to use for ensuring that bolts have been installed above the specified minimum tension values. Used properly they positively ensure the correct amount of clamping force. **Readers who have installed HSFG bolts using “torque/tension” values will notice that this manual does not relate torque to tension. Torque, or twisting force, is not a reliable measure of bolt tension. DTIs measure tension regardless of applied torque.**

The TurnaSure® DTI is washer-shaped with protrusions, “bumps,” pressed out on one face, manufactured to exceed the provisions of BS 7644. The fact that it resembles a washer is incidental. It is, in fact, a precision made mechanical load cell; a device for tensioning HSFG bolts, which is not only covered by the British Standard but also by a tightly controlled American Standard ASTM F959M-05. When a DTI is installed on a bolt with the “bumps” placed against the underside of the bolt head there are noticeable gaps between the “bumps.” As the nut is turned and the bolt tensioned, the “bumps” flatten. When the “bumps” are flattened so that the gaps have been reduced to the required dimension, the bolt has been properly tensioned and required clamping force is present. A DTI does not make it more difficult to tension a bolt, it merely shows that the bolt has been properly tensioned. (Figure 3)

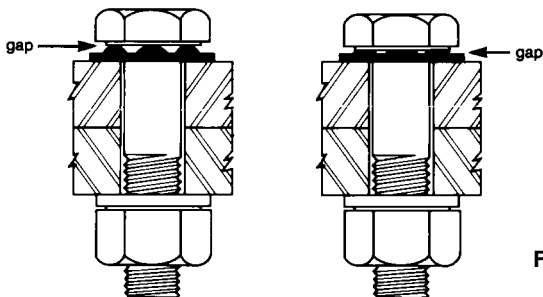

Figure 3

Direct Tension Indicators are supplied either “self colour” that is without a coating, or Sherardized to BS 4921 1988, or mechanically galvanized to BS 7371 (Part 7) or ASTM B695 (Class 50) as appropriate. They are also produced from “weathering steel” for use with bolts to BS 4395 made from heat treatable grade weathering steel. This is limited to Part 1 General Grade bolts only. Other coatings may be available upon enquiry.

DTIs are usually installed under the bolt head and the nut turned. When the bolt is properly tensioned the gap will be less than 0.40mm in more than half of the spaces. If installed under the element turned, i.e. the nut, then a .25MM feeler gauge is used. For BS 4395 Part 2 HSFG Bolts and Nuts a .50MM or a .35MM (for under nut) feeler gauge is sometimes used as the maximum average, and if desired a .40MM or a .25MM as the minimum average gaps. Coated DTIs are installed using a 0.25MM criteria. To assure that the DTI is properly installed, feeler gages, 0.40MM and 0.25MM thick, can be provided with DTI shipments. To ensure that the DTI is properly compressed, and the bolt tensioned, the appropriate feeler gage must be refused in a given number of gaps between the “bumps.” It must be emphasized that especially with these newly designed DTIs *zero gap should not be cause for rejection.* (Table 1 lists the number of “bumps” for each size and grade of DTI and the required number of gage refusals in the gaps.)

Table 1

| Bolt Size | Grade 1 (8.8) | | Grade 2 (10.9) | |
|------------------|----------------------|-----------------|-----------------------|-----------------|
| | Bumps | Refusals | Bumps | Refusals |
| M12 | 4 | 3 | — | — |
| M16 | 4 | 3 | 4 | 3 |
| M20 | 5 | 3 | 5 | 3 |
| M22 | 5 | 3 | 6 | 4 |
| M24 | 6 | 4 | 7 | 4 |
| M27 | 6 | 4 | 7 | 4 |
| M30 | 7 | 4 | 8 | 5 |
| M33 | — | — | 8 | 5 |
| M36 | 8 | 5 | — | — |

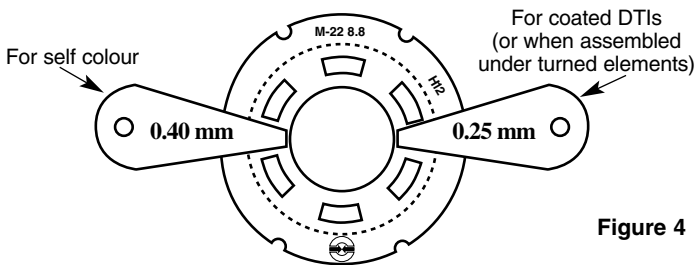

Figure 4

When inserted the feeler gage must be pointed at the center of the bolt and be at the center of the space. “Notches” in the O.D. of the redesigned DTIs assist in feeler gage inspection as the notch corresponds to and is in alignment with each feeler gauging space. (Figure 4).

Usually, erection staff develop a “feel” for installation and can install DTIs to the correct gap by eye. Inspectors will want to verify that the correct gap has been achieved using a feeler gage on a limited number of DTIs and then compare other gaps by eye. Fully compressed DTIs should not be rejected. Some inspectors judge that a bolt which has fully compressed a DTI is “over tensioned”. Much experience has not identified a problem of “over tensioning” particularly with Part 1 HSFG bolts. Many experts believe that unless a tensioned bolt has broken it is acceptable. Further support for this recommendation can be found in a report published in Volume 36, No. 1 of the Engineering Journal, (Published by the American Institute of Steel Construction, or AISC) entitled “The Effects of Over-Compressing ASTM F959 Direct Tension indicators on A325 Bolts Used in Shear Connections”. This is Available from your TurnaSure distributor.

BOLT TENSIONING USING SELF COLOUR DTIs

METHOD #1—(PREFERRED METHOD)

DTI Under the Bolt Head—Turn the Nut to Tension

This method should be used whenever possible as it ensures that the bolt has not been trapped by movement of the steel plies before tightening. Other methods are suggested but should only be used when this one cannot be.

ASSEMBLY

Put the DTI under the bolt head with the bumps facing the underside of the bolt head. Put a hardened washer under the nut. (Figure 5a)

With a short-slotted or oversized hole under the bolt head add a hardened flat washer between the DTI and the hole. (For a long slotted hole, an external cover plate of sufficient size to completely cover the slot should be provided at a minimum of 8mm thick). (Figure 5b).

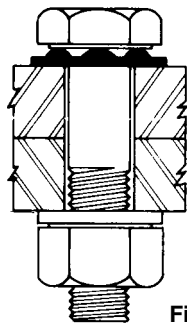

Figure 5a

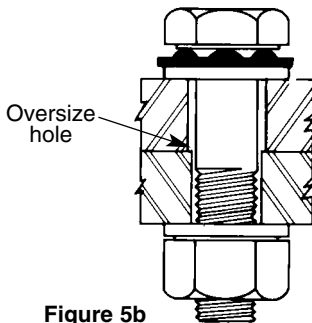

Figure 5b

TENSIONING

For Part 1 bolts turn the nut until the gap between the bolt head and the DTI face is reduced to less than 0.40mm in more than half of the entry spaces. For Part 2 (10.9) reduce gaps to less than 0.50mm and if desired not less than 0.40mm. When turning the nut, prevent the bolt head from spinning with a podger spanner. Spinning can cause unnecessary wear.

BOLT TENSIONING USING SELF COLOUR DTIs (Continued)

METHOD #2--(ALTERNATE METHOD)

DTI Under the Nut--Turn the Nut to Tension

This method should be used when the preferred method cannot be used. It is usually limited to an installation where the DTI cannot be inspected for the proper gap if it is under the bolt head.

ASSEMBLY

Place the DTI under the nut with the bumps facing the nut. (Figure 6a). With a short-slotted or oversized hole under either the bolt head or nut add a hardened flat washer between the DTI and the hole. (For a long slotted hole, an external cover plate of sufficient size to completely cover the slot should be provided at a minimum of 8mm thick). (Figures 6b, and 6c)

Note A: *The new TurnaSure DTIs do not need nut-face washers.* Nut-face washers were for DTIs with the older design "straight-sided" protrusions (as depicted in Figures 12 and 13 on page 20). With the old design DTIs a nut-face washer has to be used between the nut and DTI to achieve consistent assembly loads. However, nut-face washers are currently required by BS 7644.

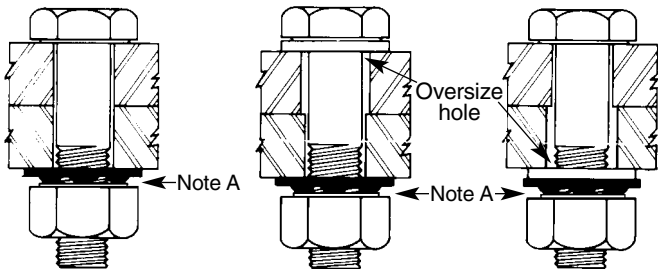

Figure 6a

Figure 6b

Figure 6c

TENSIONING

For Part 1 bolts turn the nut until the gap between the nut and the DTI face is reduced to less than 0.25mm in more than half of the entry spaces. For Part 2 (10.9) reduce gaps to less than 0.35mm and if desired not less than 0.25mm. When turning the nut, prevent the bolt head from spinning with a podger spanner.

BOLT TENSIONING USING PLAIN FINISH DTIs

METHOD #3—(ALTERNATE METHOD)

DTI Under the Bolt Head—Turn the Bolt Head to Tension

Like method #2 this method can be used when the preferred method cannot be used, such as when the tightening tool can only be placed on the head of the bolt and the DTI cannot be inspected for the proper gap if it is under the nut.

ASSEMBLY

Place the DTI under the bolt head with the bumps facing the bolt head. (Figure 7a). With a short-slotted or oversized hole under either the bolt head or nut, add a hardened flat washer. (For a long slotted hole, an external cover plate of sufficient size to completely cover the slot should be provided at a minimum of 8mm thick). (Figures 7b and 7c)

Note B: *The new TurnaSure DTIs do not need bolt-face washers.* Bolt-face washers were for DTIs with the older design “straight-sided” protrusions (as depicted in Figures 12 and 13 on page 20). With the old design DTIs a bolt-face washer has to be used between the nut and DTI to achieve consistent assembly loads. However, bolt-face washers are currently required by BS 7644.

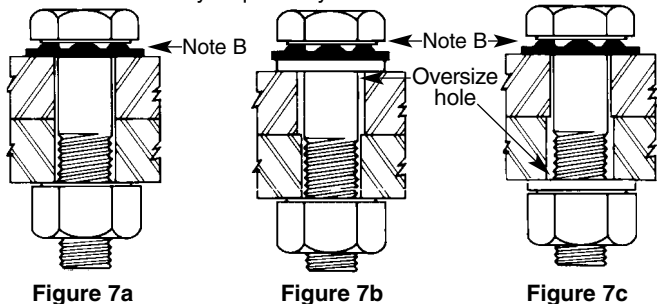

TENSIONING

For Part 1 bolts turn the bolt head until the gap between the nut and the DTI face is reduced to less than 0.25mm in more than half of the entry spaces. For Part 2 (10.9) reduce gaps to less than 0.35mm and if desired not less than 0.25mm. When turning the bolt head, prevent the nut from spinning with a podger spanner.

BOLT TENSIONING USING COATED DTIs

METHOD #1—(PREFERRED METHOD)

DTI Under the Bolt Head—Turn the Nut to Tension

Coated DTIs should be assembled under head whenever possible as it ensures that the bolt has not been trapped by movement of the steel plies before tightening. Assembly and tensioning should proceed as with self colour. With a short-slotted or oversized hole under either the bolt head or nut, add a hardened flat washer. (For a long slotted hole, an external cover plate of sufficient size to completely cover the slot should be provided at a minimum of 8mm thick). (Figure 8b).

For mechanically galvanized, sherardized or weathering steel DTIs the gap between the bolt head and the DTI face should be reduced to less than 0.25mm in more than half of the entry spaces. (Figure 8a).

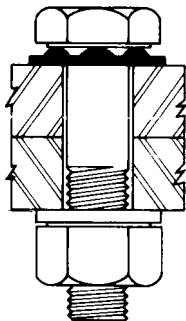

Figure 8a

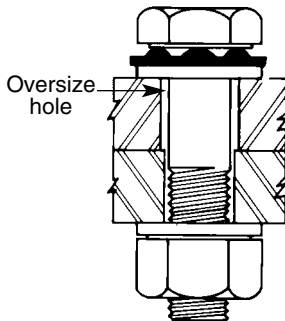

Figure 8b

BOLT TENSIONING USING COATED DTIs (Continued)

METHOD #2—(ALTERNATE METHOD)

DTI Under the Nut—Turn the Nut to Tension, or

METHOD #3—(ALTERNATE METHOD)

DTI Under the Bolt Head—Turn the Bolt Head to Tension

If using these installation procedures, for Part 1 bolts, the DTIs should be compressed to a gap of less than 0.25mm in all of the entry spaces. (Figures 9a and 10a). With a short-slotted or oversized hole under either the bolt head or nut, add a hardened flat washer. (For a long slotted hole, an external cover plate of sufficient size to completely cover the slot should be provided at a minimum of 8mm thick). (Figures 9b, 9c, 10b and 10c).

Note C: The new TurnaSure DTIs do not need nut-face or bolt-face washers. These extra washers were for DTIs with the older design “straight-sided” protrusions (as depicted in Figures 12 and 13 on page 20). With the old design DTIs extra washers have to be used between the nut and DTI to achieve consistent assembly loads. However, nut-face and bolt-face washers are currently required by BS 7644.

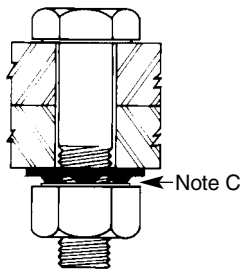

Figure 9a

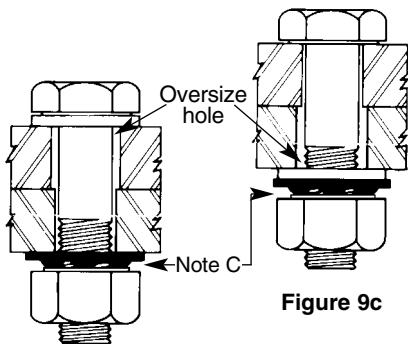

Figure 9b

Figure 9c

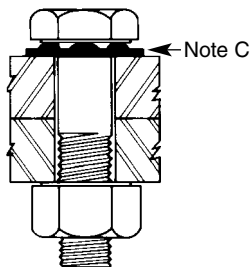

Figure 10a

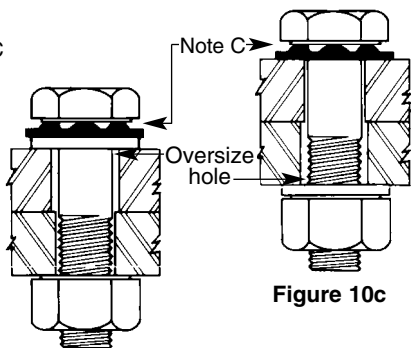

Figure 10b

Figure 10c

RECOMMENDED BOLT INSTALLATION PROCEDURE

Step 1

Bring the members to be joined together and align the holes with drift pins. (Bolts should not be used as drift pins to achieve alignment.)

Step 2

Fill the remaining holes with High Strength Friction Grip bolts, nuts, washers, and DTIs of the correct size and grade. Partially tension the bolts to snug the connection. Partial tension is evidenced by slight, but visible, flattening of the DTI protrusions. At this point there will be as much as 50% of the minimum specified tension in the bolt. This amount of tension should be sufficient to produce a snug connection. If the protrusions in a DTI are compressed so that any gap is less than final installation gap (e.g. 0.40mm) replace the DTI. Work from the most rigid part of the connection to the free edges.

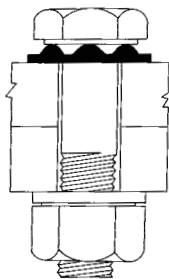
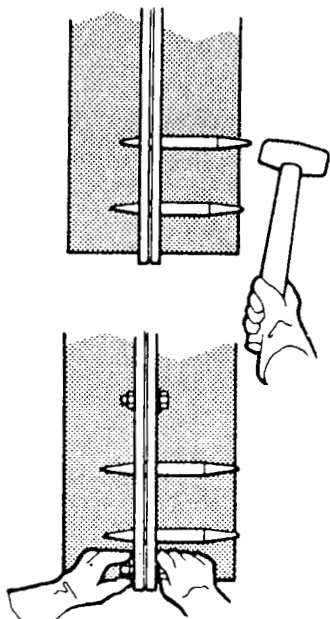

No Tension

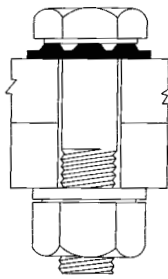

**Partial Tension
"Snug"**

Step 3

Tension the bolts until the average gap on each DTI is as specified. Again, work from the most rigid part of the connection toward the edges. Leave the drift pins in during this operation. Premature removal of the drift pins may cause trapping of the bolts by joint slippage.

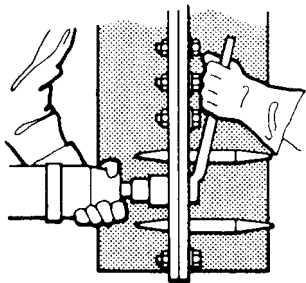

Step 4

Knock out the remaining drift pins, replacing them with bolts. Tighten these bolts.

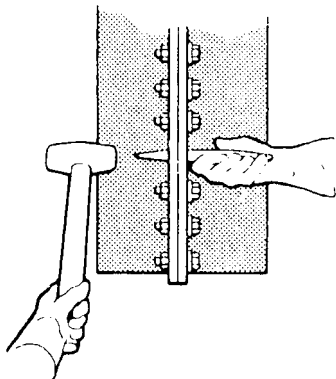

Notes

On Part 2 HSFG bolts, try not close all the gaps to nil. There is no need to tension these bolts (which have less ductility than Part 1 bolts) that much. However a nil gap should not be cause for rejection. If there is a concern about “over tensioning,” remove a sample number of bolts from the work and inspect them for deformation by running the nut down to the thread run out. If the nut runs down there is no excessive elongation. Note however if the removed bolt is Part 2 (10.9) or galvanized Part 1 bolt it cannot be reused. When using impact wrenches, final tightening should be accomplished in 10 seconds or less. Large HSFG bolts may take as long as 20 seconds. If these limits are exceeded check to see that the correct tools are being used or that one of the problems listed on pages 14 and 15 is not being encountered.

PROBLEMS COMMONLY ENCOUNTERED WHEN TENSIONING BOLTS

Dry or Rusty Threads or Nut Faces—Usually caused by poor storage conditions, dry or rusty bolts, nuts or washers should not be permitted. Ideally nuts, bolts, washers and DTIs should be kept in dry storage and their containers not opened until immediately before use. Rust significantly increases the amount of torque required to tension a bolt. Ideally nuts should be wax dipped before use, particularly on large Part 2 (10.9) bolts. Lubricant on the face of the nut is very desirable. If it is necessary to lubricate bolts at the site at the time of installation. A tallow type lubricant or high pressure grease is recommended. It is available from many sources. **The necessity of adequate lubricant to achieve the desired level of bolt pretension cannot be over-emphasized.**

Galvanized Nuts and Bolts—Hot dipped or mechanically galvanized nuts should have threads tapped oversize. Mechanically galvanized nuts are tapped before galvanizing. This prevents the galling and “lock up” of the threads resulting in failure by torsional shear.

Damaged Threads—Usually caused by forcing the bolt through misaligned holes, this will cause the nut to “freeze” or “lock up”.

Trapped Bolts—Usually caused by slippage in the joint as a result of removal of drift pins before enough bolts have been tensioned to prevent slippage. Trapped bolts cannot develop tension along their entire length.

Oversized Holes—Hardened washers are required to cover oversized and slotted holes, which are necessary to prevent the dishing of DTIs as well as the washer. (For a long slotted hole, an external cover plate of sufficient size to completely cover the slot should be provided at a minimum of 8mm thick).

REUSE OF DIRECT TENSION INDICATORS ON HIGH STRENGTH FRICTION GRIP BOLTS

The question has been raised as to whether it is permissible to reuse Direct Tension Indicators (DTIs). This notice is intended to clarify that the reuse of DTIs is not recognized by this manufacturer as a viable and accurate means to assure that required clamp force has been generated in friction-grip connections. DTIs, like other fasteners, plastically deform during use. Thus, reuse of such fasteners cannot be assumed to be sound engineering practice. Note: BS 4604 Part One states that HSFG Bolts, Nuts and Washers are not to be re-used.

AIR-TOOL SELECTION AND PERFORMANCE

Air driven impact wrenches are the prevalent tool for installing HSFG bolts. These wrenches require between 25 and 120 cu. ft./min. of air at a pressure of 100psi, at the tool, while running, to deliver a particular torque. The torque required to install an HSFG bolt to the correct tension varies with the size and grade of the bolt, and with the bolt and nut thread condition. **There are no specific relationships between torque and tension.**

Assuming the wrench is of adequate size, if problems are encountered in compressing DTIs within the time span noted, check the equipment for:

- Insufficient air pressure at the compressor.
- Too many tools running at one time.
- Too long an air line, or leaks in the air line.
- Blockage of the inlet or outlet filter on the tool.
- Broken tool.

If the tool is merely sluggish, blow it out with solvent to clean it and relubricate it with a light oil, SAE 5 or 10.

The chart below gives a rough guide to the suitable tool, based on our field experience.

| Bolt Size | | Chicago | Ingersoll | Norbar | CLECO |
|-----------|--------|-----------|------------|--------|--------|
| Part 1 | Part 2 | Pneumatic | Rand | | |
| M16 | — | 610 | 2934 | — | WS2110 |
| M20 | M16 | 610 | 2934/40 | — | WS2110 |
| M22 | M20 | 611 | 2940 | — | WS2110 |
| M24 | M22 | 6120 | 2950 | — | WS2120 |
| M27 | M24 | 6120 | 2950 | — | WS2120 |
| M30 | M27 | 6210*/614 | 2950*/5980 | PT6 | — |
| — | M30 | 614* | 5980 | PT7 | — |
| M36 | M36 | 614* | 5980 | PT7 | — |

*Only if the bolt and nut are well lubricated.

When tensioning large HSFG bolts, hydraulic wrenches should be considered as an alternative to air driven impact wrenches. Also ask your TurnaSure distributor about a new series of easy to use constant velocity electric wrenches with reaction arms for easier tightening of bolts from one end.

CHECKING FOR CONFORMANCE TO SPECIFICATIONS

Identification and Certification

Inspectors should check that all fastener components conform to applicable Standards before use. Manufacturers' marks should be clearly identifiable on all fasteners. Where required, test certificates should accompany product to the job site. Bolt certificates should state tensile strength and hardness. Nut certificates should state hardness and proof-load. Hardened washer certificates should identify that they are at the correct hardness range of 38 to 45 Rockwell C. The DTIs are marked to identify the lot number, manufacturer and Grade (M8.8 for Part 1 or 10.9 for Part 2).

TurnaSure DTIs are carefully tested throughout the manufacturing process utilizing statistical process control procedures. The finished product is tested by an independent accredited laboratory on a Digital Compression Load Analyzer with a dial gage (per ASTM F606).

Certification of testing, equals and exceeds BS 7644 requirements. The certificate shows 29 pieces per lot, without failure, in the self colour condition. (DTIs coated by TurnaSure LLC will still achieve the reported compression loads on the original test certificates). This is as per ASTM F959M-05 protocol and laboratory duplication of this product performance test by the user should not be required. There should be no attempt to reproduce the product performance test in the field. Instead, the following test of the DTI and bolt/nut/washer assembly in a bolt load meter is suggested. This will assist the user in qualifying all of the components, and verifying their compatibility.

Field Verification Test for Bolt Assembly Performance

Assemble the bolt, nut, washer and DTI in a bolt load meter as shown in Figure 5.

Verify that the bolt load meter has been certified and calibrated within the last year. The calibration certificate shall be supplied by an organization approved by UKAS (NAMAS) with the results traceable to National Standards.

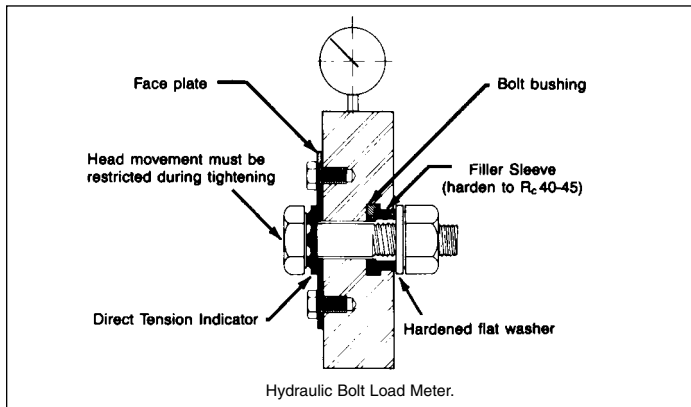

Figure 5

Tension the bolt to the minimum required bolt tension and check that the applicable feeler gauge enters as least the proper number of spaces (tension and spaces given in Table II). A 0.40mm feeler gauge is used when a self colour DTI is installed under the bolt head and the nut is turned per Method #1 for Part 1 bolts and a 0.50mm feeler gauge is used for Part 2 (10.9) bolts. A 0.25mm feeler gage is used with Methods #2 and #3 for Part 1 bolts and a .35mm for Part 2 bolts. 0.25 mm gauge is used for Part 1 coated DTIs in any arrangement, and again, a .35mm is used on Part 2 (10.9) bolts. The load should be increased on the bolt load meter as smoothly as possible so as to avoid “fallback” where the load cell “bleeds off” and the meter starts to show a lower load than the actual bolt load. At this point the assembly has demonstrated the ability to reach the desired tension prior to compression of the number of bumps which are required to be compressed in the work.

Next tension the bolt until the point where the feeler gage refuses to enter the number spaces in Table II. The tension in the bolt as measured by the meter must be less than the minimum ultimate load of the bolt for Part 1 bolts. In the case of Part 2 (10.9) bolts it must be less than the maximum tension in Table 11. At this point the assembly has demonstrated the ability to compress the bumps to the gap required in the work without exceeding the minimum tensile strength of the bolt or the maximum for Part 2 (10.9) bolts.

If an impact wrench is used to tension the bolts in the meter, the impact wrench should not be used to exceed 2/3 of the required tension. A spanner should be used to bring the load up to the value specified.

| Table II | | | | | | |
|-----------------------|-------------------------------|--------------------------------|-------------------|----------------------------|-----------------------------|-----------------------------|
| Grade 1 (8.8) | | | | | | |
| Bolt Size | Minimum Bolt Load (kN) | Min. Ultimate Bolt Load | | DTI Spaces | Feeler-Gage Entries | Feeler-Gage Refusals |
| | | Load-Min (kN) | DTI | | | |
| M12 | 49.4 | 69.6 | 4 | 2 | 3 | |
| M16 | 92.1 | 130 | 4 | 2 | 3 | |
| M20 | 144 | 203 | 5 | 3 | 3 | |
| M22 | 177 | 250 | 5 | 3 | 3 | |
| M24 | 207 | 292 | 6 | 3 | 4 | |
| M27 | 234 | 333 | 6 | 3 | 4 | |
| M30 | 286 | 406 | 7 | 4 | 4 | |
| M36 | 418 | 591 | 8 | 4 | 5 | |
| Grade 2 (10.9) | | | | | | |
| Bolt Size | Bolt Load Min. (kN) | Bolt Load Max. (kN) | DTI Spaces | Feeler-Gage Entries | Feeler-Gage Refusals | |
| M16 | 103.9 | 140.5 | 4 | 2 | 3 | |
| M20 | 161.8 | 219.0 | 6 | 3 | 4 | |
| M22 | 200.2 | 270.8 | 6 | 3 | 4 | |
| M24 | 233.4 | 316 | 7 | 4 | 4 | |
| M27 | 303 | 409 | 7 | 4 | 4 | |
| M30 | 370 | 500 | 8 | 4 | 5 | |
| M33 | 459 | 621 | 9 | 5 | 5 | |

Note: For Grade 2 (10.9) DTIs, if the engineer is concerned about exceeding the “bolt load maximum” then simply make sure at “bolt load maximum” figures a feeler gauge per the sizes detailed in the bolt tensioning section (i.e. the same gauge sized used for grade 1 DTIs) also refuses at least the number of spaces in the “minimum gauge refusals” column above.

DTI IDENTIFICATION MARKINGS

TRADEMARK

The trademark of TurnaSure LLC is shown on the cover of this booklet. DTIs marked with it have been manufactured by TurnaSure LLC of the U.S.A.

GRADE AND SIZE

Each DTI is marked with a series of numbers. "M-8.8" signifies the DTI is for use with BS 4395 Part 1 HSFG bolts. "10.9" is for BS 4395 Part 2 HSFG bolts. DTIs for use with weathering steel will be marked "M-8.8-3".

LOT NUMBER

For purposes of absolute traceability TurnaSure LLC's DTI requires each DTI be marked with a lot number. The lot number will take the form of a letter followed by either one or more numbers. Figure 11 illustrates the new and improved 8.8 DTI design.

CIRCUMFERENTIAL NOTCHES

The redesigned DTIs have circumferential indentations spaced equally around the outside circumference, corresponding to and in alignment with each feeler gauge entry space.

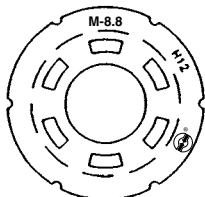

Figure 11

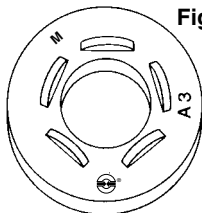

Figure 12

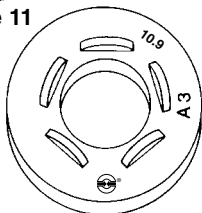

Figure 13

Older designs look like Figures 12 & 13



TurnaSure LLC

International Headquarters
340 E. Maple Avenue, Suite 206
Langhorne, PA 19047

Phone: 215-750-1300
Fax: 215-750-6300
Website: www.turnasure.com