



## THE INSTRUMENT CLUSTER DISPLAYS VARIOUS CHECK CONTROL MESSAGES

New information provided by this revision is preceded by this symbol  .

This Service Information bulletin replaces SI B61 21 15 **dated June 2018**

### What's New:

- Warranty Information section updated for CPO (Certified Pre-Owned) vehicles

### MODEL

F25 (X3)	F26 (X4)		
Produced up to July 31, 2016			

### SITUATION

The instrument cluster displays various check control messages. This includes messages for the PDC (Park Distance Control), DSC (Dynamic Stability Control) and windshield washer system.

There can be many different fault codes stored in the vehicle, including:

Control Module	Fault Code	Fault Description
ICM_25	4827BA	ICM: Procedure error detected
ACSM4	C9542D	Signal (driving speed, 0x19F) invalid, transmitter ICM
DSC_25	480715	Wheel speed sensor: Voltage supply, short circuit, front right
ICM_25	D017C6	Signal (actual wheel speed, 46.0.1) undefined, transmitter DSC
MEVD172Y	1B0A60	Driving speed, plausibility: Minimum speed under load implausible
IHKA25	E71442	Interface instrument panel (distance travelled, kilometer's, 0x330): Signal invalid
DSC_25	480AA3	Wheel speed sensor: Wrong variant, front right
MEVD172Y	1B0A21	Rough road detection: No wheel speed signal received

ICM_25	D017A3	DSC interface (actual number of sensor edges wheel, 64.1.2): Signal invalid
DSC_25	48068C	Transfer box: Temporary fault, temperature
MEVD172Y	1B0A67	Vehicle speed, front/right wheel speed sensor, signal change: Not plausible
ICM_25	D017C5	Interface DSC (actual speed, wheel, 46.0.1): Signal invalid
MEVD172Y	1B0A61	Driving speed, plausibility: Minimum speed in coasting/overrun mode implausible
EMF_10	D3AC8D	DSC interface (status, hydraulic function, 25D): Signal invalid
ICM_25	48002C	ICM, ACC: Interface DSC
DSC_25	480AA6	Wheel speed sensor: Plausibility, signal fault, front right
DSC_25	D36D44	Signal (longitudinal torque distribution, front axle/rear axle, 19.3.4) invalid, transmitter VTG
MEVD172Y	1B0A62	Driving speed, plausibility: Road speed signal implausible
HUD_01	D86C07	Interface INSTR. CL. (kilometer reading, 0x330): signal invalid
DSC_25	480AA5	Wheel speed sensor: Plausibility, signal spike, front right
DSC_25	480713	Wheel speed sensor: Plausibility, direction of rotation, front right
PDC_01	E2170C	Interface INSTR. CL. (outside temperature, 0x2CA): signal invalid
ICM_25	D0142C	Instrument panel interface (ambient temperature, 252.1.4): Signal invalid
MEVD172Y	10B101	Outside temperature sensor, electrical: Short circuit to B+
MEVD172Y	10BA41	Outside temperature sensor, plausibility: Ambient temperature less than model temperature
KOMB01	B7F655	Instrument panel: Outside temperature sensor Short circuit to B+
DSC_25	D3542C	KOMBI interface (outside temperature, ID: 0X2CA): Signal invalid
TR SVC01	CAAC0F	Interface INSTR. CL. (outside temperature, 0x2CA): signal invalid
IHKA25	E71417	KOMBI interface (outside temperature,

0x2CA): Signal invalid
------------------------

## CAUSE

The wiring harness below the micro filter housing (right front area of the bulkhead) is damaged from washer fluid leaking into the harness.

## CORRECTION

Check and replace the right front "repair" wiring harness (improved part) listed below.

## PROCEDURE

1. Perform a vehicle test with ISTA and if the faults listed above are stored, **proceed to the next step**.
2. Inspect the wiring for damage.
3. Remove the right front wheel and wheel arch cover.
4. Remove the micro filter housing.
5. Inspect the harness coming through the bulkhead in the right front engine compartment area for any signs of swollen wires (remove the electrical tape to expose the wires).
6. If the wires are swollen, refer to the attached procedure to install a repair wiring harness and to check and correct the washer fluid line leak.

Always connect a BMW approved battery charger / power supply ([SI B04 23 10](#)).

## PARTS INFORMATION

Part Number	Description	Quantity
Refer to ETK	Repair wiring harness section with foamed grommet for connection in vehicle interior	1
61 12 6 825 706	Cover	1

## WARRANTY INFORMATION

Covered under the terms of the BMW New Vehicle Limited Warranty for Passenger Cars and Light Trucks or the BMW Certified Pre-Owned Program

<b>Defect Code:</b>	<b>6111900100</b>	
<b>Labor Operation:</b>	<b>Labor Allowance:</b>	<b>Description:</b>
00 63 789	Refer to KSD2/AIR	Check wiring harness for engine compartment on the right and install repair wiring harness section with grommet (includes connecting an approved battery charger/power supply and performing a vehicle test) (Plus work)

Refer to KSD2/AIR for the corresponding flat rate unit (FRU) allowance.

### Other Repairs

**UPDATE !**

If the wiring is found **not** to be the cause and performing the ISTA diagnostics and related test plans results with other eligible and covered work, claim this work with the applicable defect code and labor operations (including diagnosis) listed in KSD2/AIR.

**UPDATE !**

### **Overlapping Labor Procedure – Other Repairs**

If invoicing the KSD2/AIR flat rate labor operation codes for other repair work results in overlapping labor, for those flat rate labor operations that are affected, you are able to:

- Replace the stated KSD2 “FRU allowance” with a “reduced FRU value” to eliminate the overlapping labor.

For help in identifying the overlapping labor, please refer to the AIR FRU Plausibility Check (Overlapping Labor Tool) that is located in the AIR Client.

Eligible other repair work being claimed under a different defect code will require separate punch times.

On the repair order and in the claim comment section, please identify and itemize those labor operations being claimed with a “reduced FRU value.”

Posted: Friday, September 28, 2018

## **ATTACHMENTS**

View PDF attachment [B612115 AttachmentV3](#).

[ Copyright ©2018 BMW of North America, Inc. ]

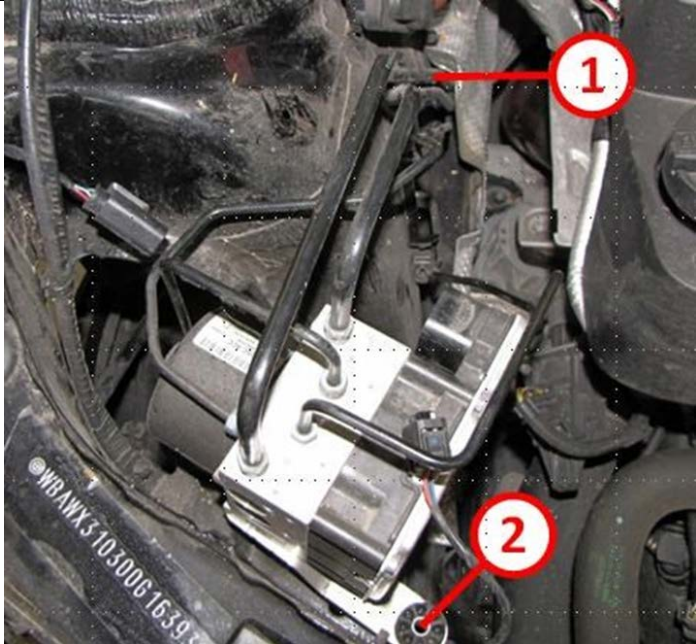
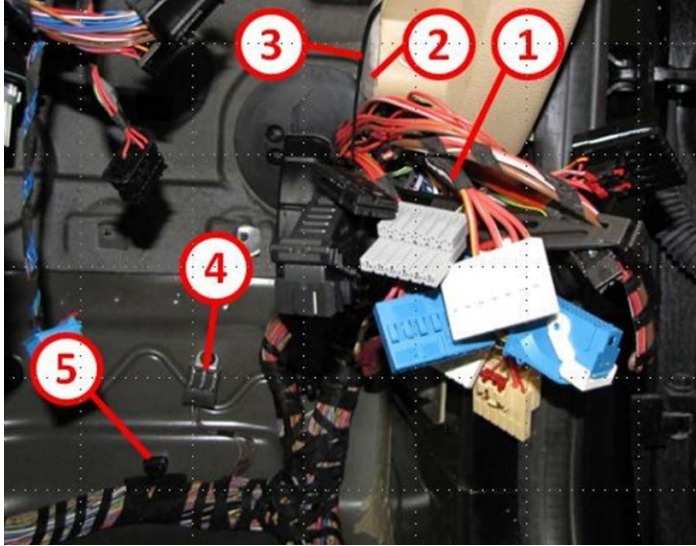
<p><b>Preliminary Work:</b></p> <ul style="list-style-type: none"> <li>• Disconnect the battery – ISTA repair instructions 61 20 900</li> <li>• Remove the microfilter housing</li> <li>• Remove the right front wheel</li> <li>• Remove the right front wheel arch cover (front section) – repair instructions 51 71 038</li> <li>• Remove the right front wheel arch cover (rear section) – repair instructions 51 71 039</li> </ul>	
	<p><b>Removal of existing wiring harness</b></p> <p><b>Behind Right Front Headlight</b></p> <ul style="list-style-type: none"> <li>• Open the brake line holder (1) where shown</li> <li>• Remove the DSC hydraulic unit mount screw (2) where shown</li> </ul>
	<p><b>Right Side of Dash</b></p> <ul style="list-style-type: none"> <li>• Remove the glove box – repair instructions 51 16 366</li> <li>• Remove the blower motor for the heating and air conditioning – repair instructions 64 11 213</li> <li>• Remove the vehicle interior fuse box – repair instructions 61 13 050</li> <li>• Remove the side trim panel for the foot well at the A-pillar – repair instructions 51 43 075</li> <li>• Lay the carpet carefully to one side</li> <li>• Secure the wiring harness (1) to the dashboard carrier (2) with a cable strap (3).</li> </ul>

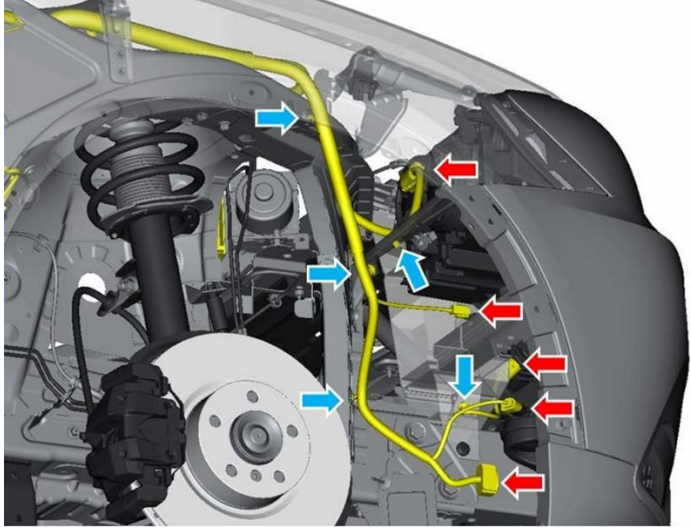
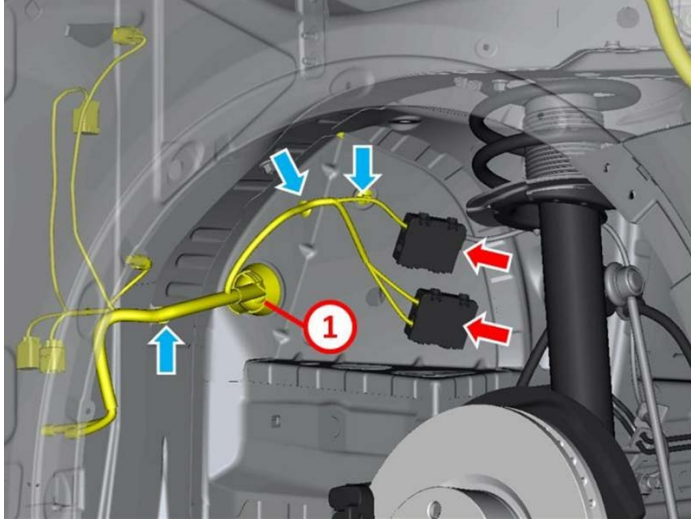
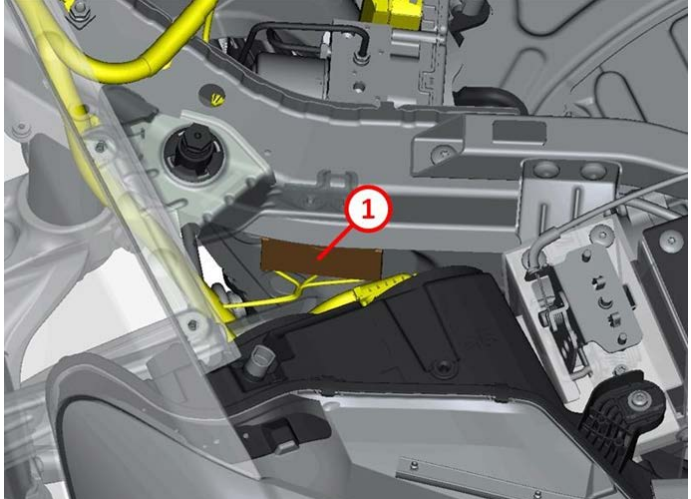
	<ul style="list-style-type: none"> <li>• Remove the nut (4)</li> <li>• Disconnect the wiring harness (5)</li> </ul>
 <p>A photograph showing the front of the right front wheel well. A yellow wiring harness runs through the area. Blue arrows point to various mounting points where the harness is secured. Red arrows point to several electrical connectors that need to be unplugged. A brake disc and suspension components are visible in the background.</p>	<p><b>Front of Right Front Wheel well</b></p> <ul style="list-style-type: none"> <li>• Unplug all the wiring harness plug connections (red arrows). Based on the vehicle options there might be more connections to unplug</li> <li>• Unfasten all the wiring harness mounting points (blue arrows)</li> <li>• Guide the wiring harness up and out of the wheel arch area</li> </ul>
 <p>A photograph showing the rear of the right front wheel well. The yellow wiring harness is being guided through the wheel arch. Blue arrows indicate the path of the harness. Red arrows point to connectors to be unplugged. A red circle with the number '1' highlights a specific opening in the body panel through which the harness must be pulled.</p>	<p><b>Rear of Right Front Wheel well</b></p> <ul style="list-style-type: none"> <li>• Unplug all the wiring harness plug connections (red arrows).</li> <li>• Pull the grommet out of the body (1)</li> <li>• Guide the wiring harness through the opening (1) into the engine compartment</li> </ul>
 <p>A photograph showing the area behind the right front headlight. A yellow wiring harness is visible. A red circle with the number '1' points to a ground comb connector that needs to be removed.</p>	<p><b>Behind Right Front Headlight</b></p> <ul style="list-style-type: none"> <li>• Remove the nut from the ground comb connector (1) and remove the ground comb</li> </ul>

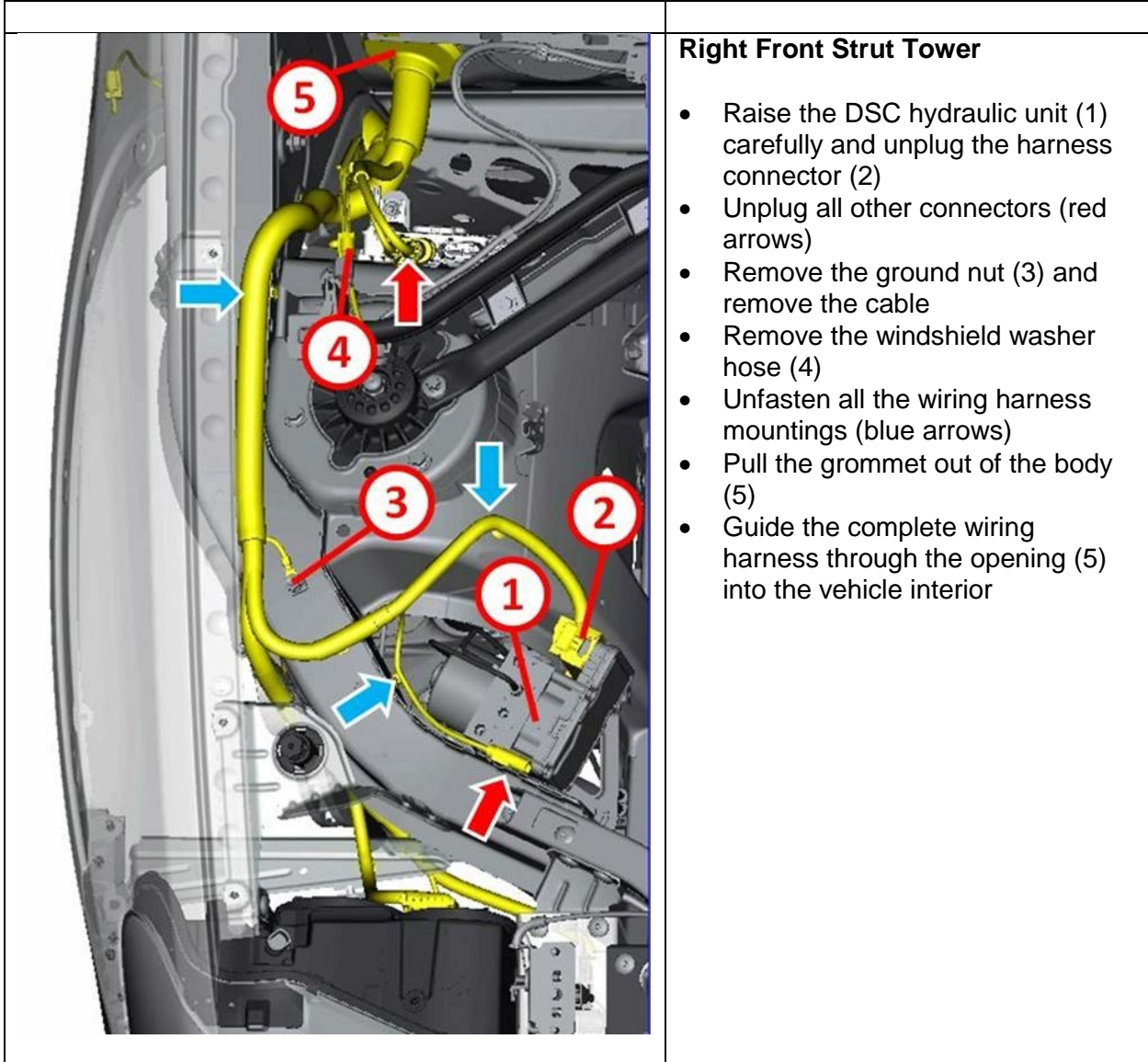

### Right Front Strut Tower

- Raise the DSC hydraulic unit (1) carefully and unplug the harness connector (2)
- Unplug all other connectors (red arrows)
- Remove the ground nut (3) and remove the cable
- Remove the windshield washer hose (4)
- Unfasten all the wiring harness mountings (blue arrows)
- Pull the grommet out of the body (5)
- Guide the complete wiring harness through the opening (5) into the vehicle interior

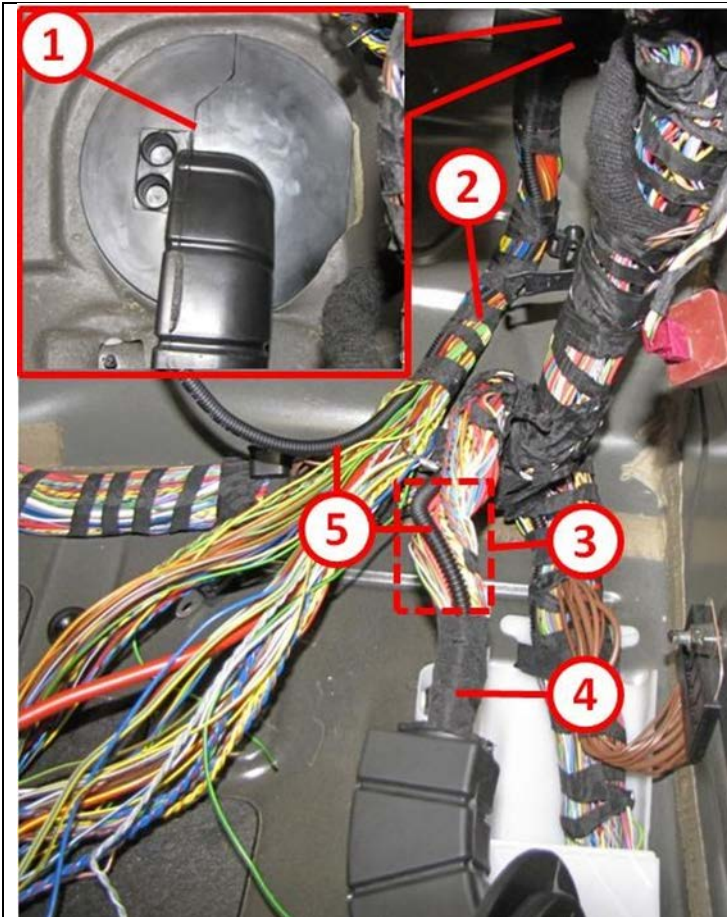

**Installation of new wiring harness**

- Guide the new wiring harness (2) from the vehicle interior into the engine compartment
- Install the grommet (1) of the new wiring harness as shown
- Place the new wiring harness (2) and the old wiring harness (4) next to each other
- The wires from the old harness (4) must be individually cut in the area (3) **NOTE: do not cut all the wires in the same location in order to prevent a lump in the harness repair**
- Crimp the wires from the existing old harness with the respective wires on the new harness and seal with heat-shrink tubing.

**Note: the following variations apply if the vehicle is equipped with SA 522 Xenon Headlights. Refer to the charts below in regards to the headlight wiring.**

**conversion instruction swollen harness F25**

headlight	the repair kit		at the vehicle			
	E5*1B	X844*2B	X844*2S	until 04/2014		
chamber in the plug	chamber in the plug	chamber in the plug	Halogen (BASIS)	AHL (S524A)	Xenon (S522A)	
1	SWG	6	6	SWG	BLBR	BLBR
2	BR	-	-	-	-	-
3	GEBL	7	7	GEBL	GEBL	GEBL
4	BR	-	-	-	-	-
5	GERT	8	8	GERT	GERT	GERT
6	WSSW	9	9	WSSW	WSSW	WSSW
7	BR	-	-	-	-	-
8	GESW	11	11	GESW	GESW	GESW
9	GEGR	12	12	GEGR	GNSW	GNSW
10	BLSW	13	13	BLSW	WSRT	WSRT
11	BLBR	14	14	BLBR	BR	BR
12	BLBR	10	10	BLBR	BLBR	BLBR

headlight	the repair kit		at the vehicle				
	E5*1B	X844*2B	X844*2S	since 04/2014			
chamber in the plug	chamber in the plug	chamber in the plug	Halogen (BASIS)	AHL (S524A)	Xenon (S522A)	LED (S552A)	
1	SWG	6	6	SWG	BLBR	BLBR	BLBR
2	BR	-	-	-	-	-	-
3	GEBL	7	7	GEBL	GEBL	GEBL	RTGE
4	BR	-	-	-	-	-	-
5	GERT	8	8	GRRT	RTGN	GNSW	RTGN
6	WSSW	9	9	WSSW	-	GERT	-
7	BR	-	-	-	-	-	-
8	GESW	11	11	GESW	WSRT	WSRT	WSRT
9	GEGR	12	12	GEGR	GEWS	-	GEWS
10	BLSW	13	13	BLSW	GESW	-	GESW
11	BLBR	14	14	BLBR	-	-	BR
12	BLBR	10	10	SWG	-	-	GESW

At the vehicle with halogen headlight, are 2 lines with the same color (BLBR) at the vehicle. after separating the lines, check on passage and suitable connect  
 FRMFA A58\*2B chamber 30, auf E5\*1B chamber 11  
 FRMFA A58\*2B chamber 8, auf E5\*1B chamber 12



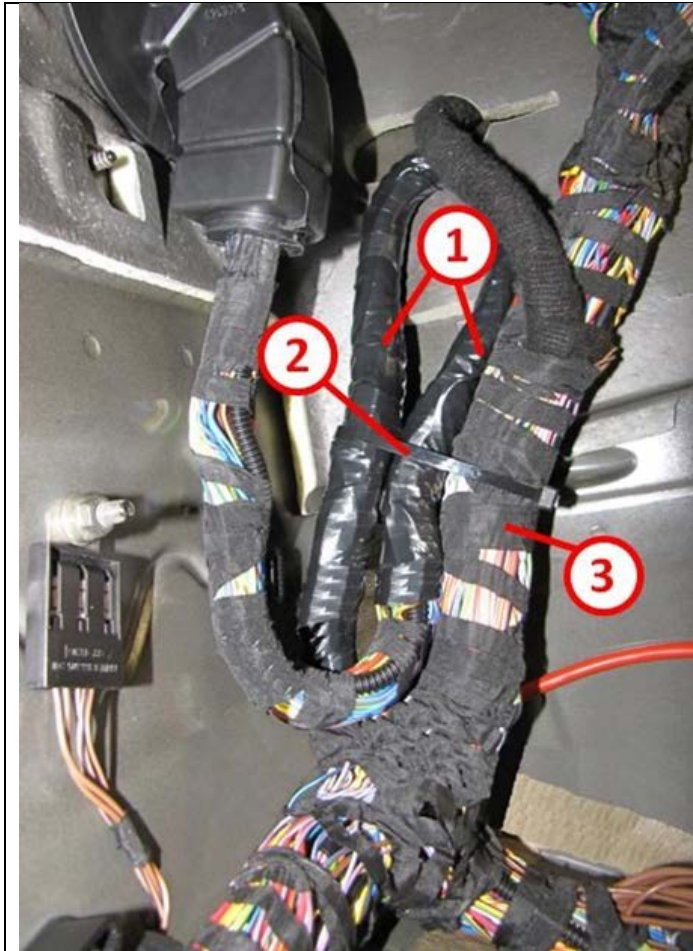

- Route the new wiring harness in the engine compartment and connect all plug connections
- Cut the windshield washer hose (5) to the correct length in order to make the connection using the repair kit provided
- Wrap the wiring harness and windshield washer hose (1) with adhesive tape
- Secure the harness (2) as shown, ensuring that the washer hose does not get kinked

	<p><b>UPDATE!</b> Before the installation of the micro filter cover box lid, install a water discharge cover tray (P/N 61 12 6 825 706) as shown.</p>
--	---

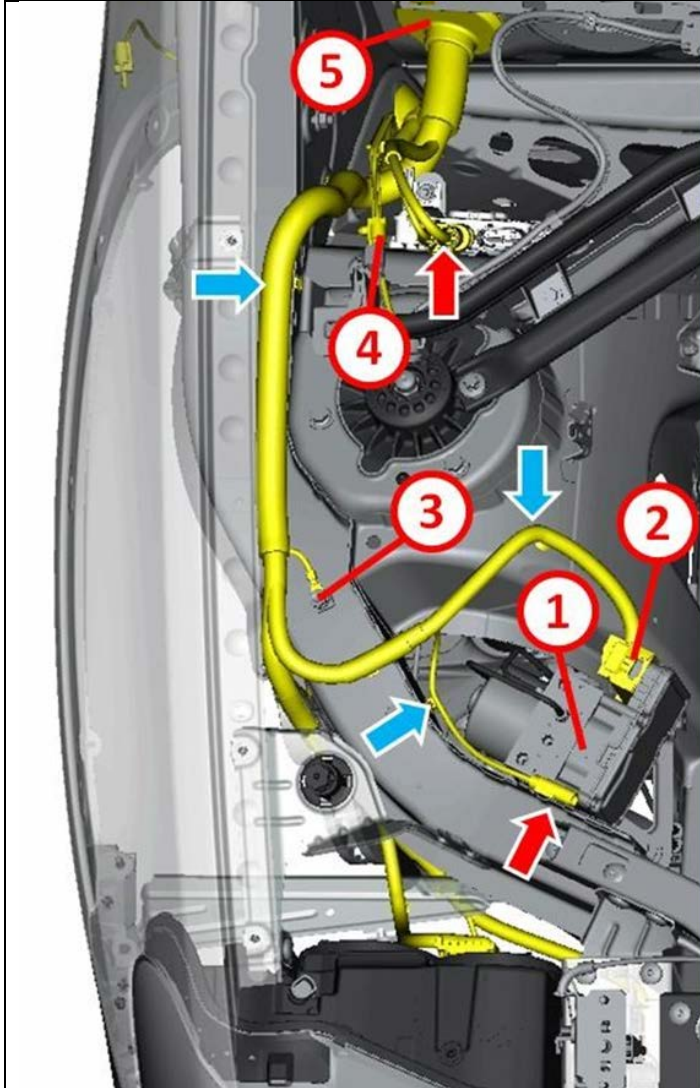

### Right Front Strut Tower

- Route the new wiring harness into the engine compartment  
Fasten all the wiring harness mountings (blue arrows)
- Install the windshield washer hose (4)
- Reinstall the ground cable and nut (3)
- Plug all connectors (red arrows)
- Raise the DSC hydraulic unit (1) carefully and plug in the harness connector (2)

**Note:** The replacement harness has a pink/blue wire instead of a red/blue wire at the DSC hydraulic unit.

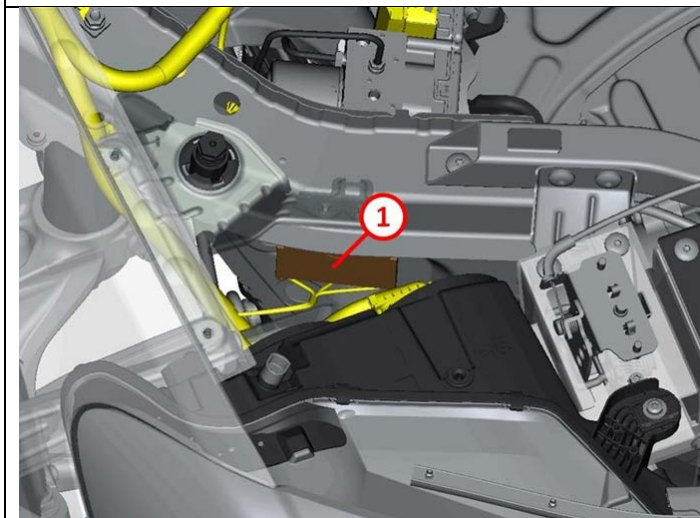

### Behind Right Front Headlight

- Mount the ground comb connector and install the nut for the ground comb connector (1)

**Note:** The wiring harness connector at the right side repeater light may be incorrectly pinned. The blue/yellow and brown wires need to be swapped at the connector.

**Pin 1 – Blue/Yellow to FRM**  
**Pin 2 – Brown to Ground Z10\*2B**

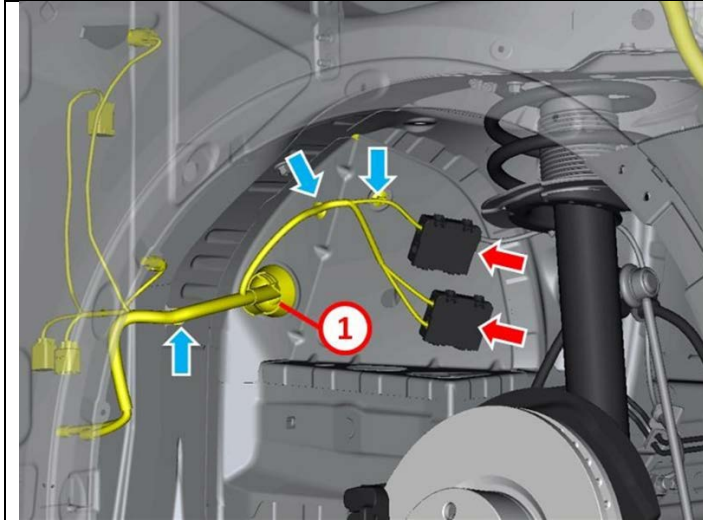

**Rear of Right Front Wheel well**

- Guide the wiring harness through the opening (1) from the engine compartment
- Mount the grommet (1) in place
- Secure the wiring harness in place (blue arrows)
- Plug in all the wiring harness plug connections (red arrows).

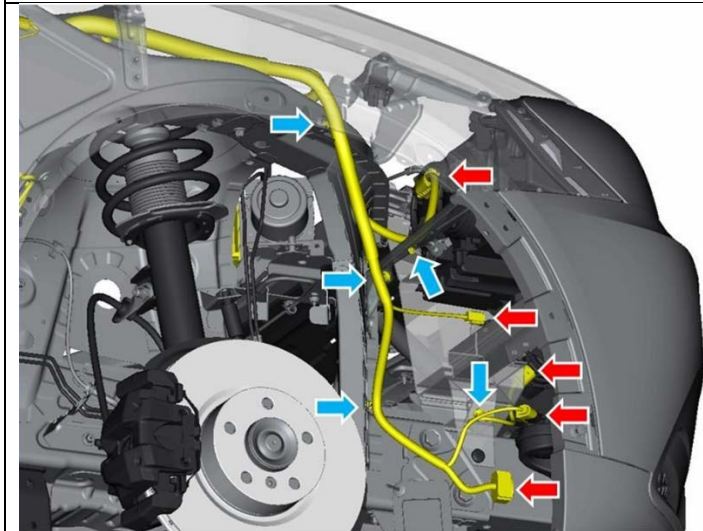

**Front of Right Front Wheel well**

- Guide the wiring harness down and into the wheel arch area
- Secure the wiring harness in place (blue arrows)
- Plug in all the wiring harness plug connections (red arrows). Based on the vehicle options there might be more connections to plug in

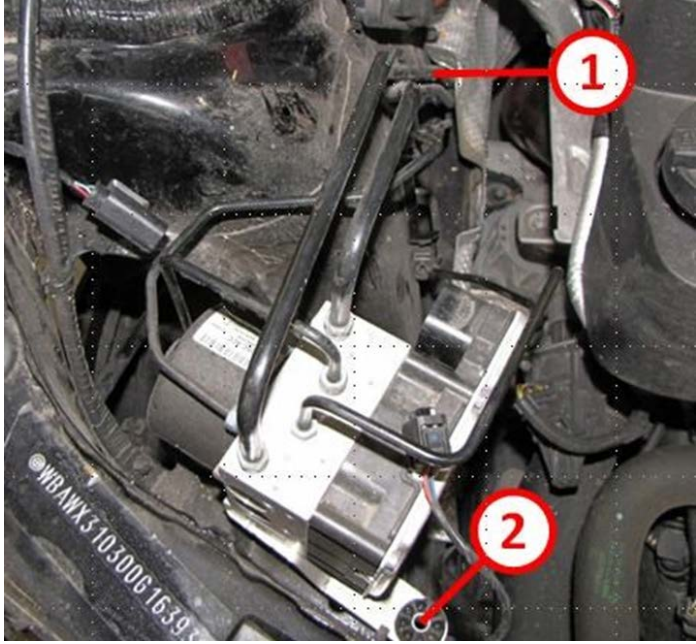
	<p><b>Behind Right Front Headlight</b></p> <ul style="list-style-type: none"> <li>• Install the DSC hydraulic screw (2)</li> <li>• Close the brake line holder (1) where shown</li> </ul>
<ul style="list-style-type: none"> <li>• After all the wiring harness connections are made, connect the battery and perform a functional check on the vehicle to make sure everything is working.</li> <li>• Verify that the windshield washer system has no leaks</li> </ul>	
<p><b>Follow-up work</b></p> <ul style="list-style-type: none"> <li>• Install the right front wheel arch cover (rear section) – repair instructions 51 71 039</li> <li>• Install the right front wheel arch cover (front section) – repair instructions 51 71 038</li> <li>• Install the right front wheel</li> <li>• Install the microfilter housing</li> </ul> <p><b>Inside the vehicle</b></p> <ul style="list-style-type: none"> <li>• Resecure the carpet</li> <li>• Install the side trim panel for the foot well at the A-pillar – repair instructions 51 43 075</li> <li>• Install the vehicle interior fuse box – repair instructions 61 13 050</li> <li>• Install the blower motor for the heating and air conditioning system – repair instructions 64 11 213</li> <li>• Install the glove box – repair instructions 51 16 366</li> <li>• Reconnect the battery - repair instructions 61 20 900</li> <li>• Retest all functions and clear all faults</li> </ul>	