

THE LITHIUM-ION BATTERY VALUE CHAIN

New Economy Opportunities for Australia

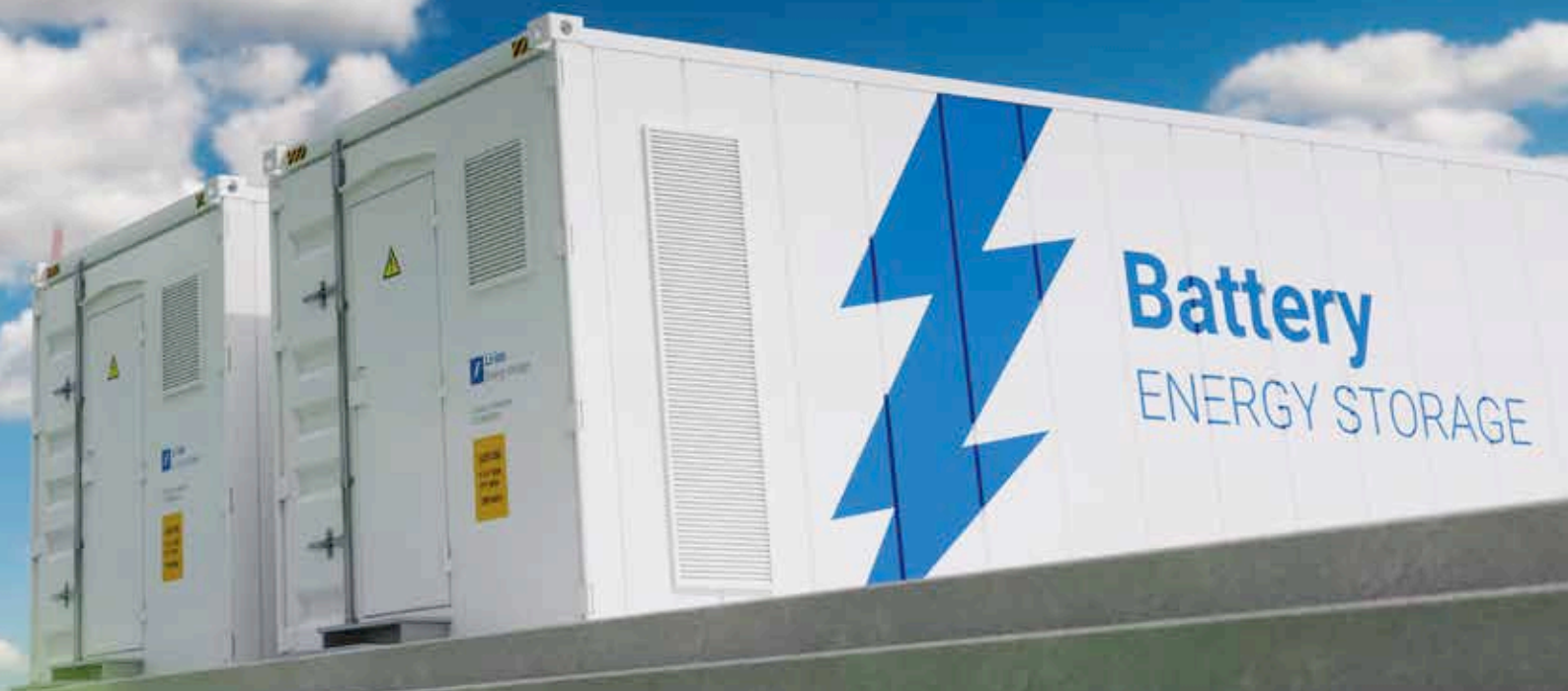

Australian Government
Australian Trade and Investment Commission



Acknowledgment

Austrade would like to express our appreciation to Future Smart Strategies, especially Howard Buckley, for his professional guidance, advice and assistance, with earlier versions of this report.

We would also like to thank Adrian Griffin at Lithium Australia for his insights and constructive suggestions.

And we would like to acknowledge the insights provided by Prabhav Sharma at McKinsey & Company.

More broadly, we would like to thank the following companies and organisations for providing data and information that assisted our research:

- Association of Mining and Exploration Australia (AMEC);
- Geoscience Australia;
- Albemarle; and
- TianQi Australia.

Disclaimer

This report has been prepared by the Commonwealth of Australia represented by the Australian Trade and Investment Commission (Austrade). The report is a general overview and is not intended to provide exhaustive coverage of the topic. The information is made available on the understanding that the Commonwealth of Australia is not providing professional advice.

While care has been taken to ensure the information in this report is accurate, the Commonwealth does not accept any liability for any loss arising from reliance on the information, or from any error or omission, in the report.

Any person relying on this information does so at their own risk. The Commonwealth recommends the person exercise their own skill and care, including obtaining professional advice, in relation to their use of the information for their purposes.

The Commonwealth does not endorse any company or activity referred to in the report, and does not accept responsibility for any losses suffered in connection with any company or its activities.

Unless otherwise specified, all amounts in this report are in Australian dollars.

Copyright © Commonwealth of Australia 2018



The material in this document is licensed under a Creative Commons Attribution – 4.0 International licence, with the exception of:

- the Australian Trade and Investment Commission's logo
- any third party material
- any material protected by a trade mark
- any images and photographs.

More information on this CC BY licence is set out at the creative commons website: <https://creativecommons.org/licenses/by/4.0/legalcode>. Enquiries about this licence and any use of this document can be sent to marketing-comms-helpline@austrade.gov.au.

Attribution

Before reusing any part of this document, including reproduction, public display, public performance, distribution, dissemination, communication, or importation, you must comply with the Attribution requirements under the CC BY licence.

17-18-140. Publication date: December 2018.

FOREWORD

The new energy revolution and accelerating growth in demand for lithium-ion batteries provides a wonderful opportunity for Australia. As the world's largest producer of lithium, with mineral reserves covering 90 per cent of the elements required in lithium-ion battery chemistry, Australia has undeniable competitive advantages that need to be explored.



Moving beyond traditional minerals extraction and exports into downstream manufacturing capabilities and associated industry value chains opens the door to a new world of possibilities. The time is right to explore Australia's full potential in lithium-ion batteries.

The lithium-ion battery is an enduring technology. It was central to the communications and technology revolution of the 1990s and it is at the forefront of how the world is addressing threshold issues such as energy storage, electric vehicles, and powering an increasingly wide range of customer appliances.

The Australian Government supports building economies of scale for products that leverage Australia's competitive advantages in natural resources, processing, infrastructure, advanced manufacturing, and technology. These industries have the potential to drive long-term economic prosperity, jobs and growth.

This report highlights Australia's strengths, but also identifies the areas where Australia needs to attract the investment, partners and technologies required to develop capability ahead of other global industry participants. Our vision is for Australia to secure an expanded place in the lithium-ion battery value chain, thereby maximising the economic benefit to all Australians.

Australia has a strong history of welcoming foreign investment in the resources and manufacturing sector, which will be crucial to realising our vision in this sector. The Australian Government is committed to maintaining an investment policy regime that is transparent, predictable and non-discriminatory. In 2017, A\$315.3 billion of foreign investment was made in the Australian mining sector. This represented 37.1 per cent of all foreign direct investment into Australia – by far the largest of all industries. The second largest was the manufacturing sector, which received 11.5 per cent of all investment.

This report sets out the potential new chapter in the story of Australia's remarkable mining and resources development. The Australian Government stands ready to capture the value this opportunity presents to ensure Australia is well positioned to grow market share in the 'new economy' minerals sector.

Senator the Hon Simon Birmingham
Minister for Trade, Tourism and Investment



CONTENTS

Introduction	05	Infrastructure	34
Lithium-ion batteries	06	Workforce and skills	34
Lithium-ion batteries and future energy storage	07	Support for innovation and high-tech industries	35
Supply and demand	08	Leading safety and environmental practices and safeguards	36
Production forecasts	09	Local drivers	37
From lithium spodumene to battery packs: how lithium-ion batteries are produced	12	Opportunity for lithium-ion battery recycling	38
Ore extraction	12	Why Australia?	40
Processing	12	A robust economy	40
Battery manufacture	14	International competitiveness	40
How competitively placed is Australia to own the supply chain?	17	Global ties	41
Mineral resources	17	Investment attractiveness	41
Chemicals and related inputs	28	Gap analysis	43
The case for lithium-ion battery production in Australia	30	What else does Australia need?	43
A missed opportunity	30	Targeting FDI and technology transfer	43
Australia's secure access to lithium-ion battery inputs	31	Case studies	43
Australian movement into the lithium supply value chain	32	Potential sites for lithium-ion battery cell manufacturing	46
Cost competitiveness	33	Incentivising investment: Commonwealth Government policy support	48
Scale and expertise of the Australian mining sector	34	List of acronyms	51
		References	52



INTRODUCTION

Lithium has been at the forefront of several important technological changes over the past three decades. The commercialisation of the lithium-ion battery in the 1990s enabled the mobile phone revolution and the smartphone and tablet industry of the late 2000s. With minimal technological development, the same batteries now underpin a new emphasis on energy storage capabilities, consumer electronics, and the global shift towards electric vehicles (EVs).

Australia is well positioned to capitalise on the significant opportunities presented by the lithium-ion battery era. Australia has the world's third-largest reserves of lithium and is the largest producer of hard-rock lithium spodumene – the largest lithium spodumene asset in the world is the Greenbushes project in Western Australia.

Australia currently produces nine of the 10 mineral elements required to produce most lithium-ion battery anodes and cathodes, and has commercial reserves of graphite – the remaining element.¹ Australia also has secure access to all of the chemicals required for lithium-ion battery production.

In addition to resource deposits, Australia has competitive supply-chain advantages. Australia's rail and port infrastructure links relevant regions of mineral production to global markets. This supports both a production capability that can supply raw and refined materials to global markets and enables efficient domestic processing and manufacturing of finished products for global markets. Australia also has world-leading expertise in resource extraction and processing, high-tech engineering and renewables research.

Australia is a highly attractive destination for foreign investment in new economy opportunities. Australia has competitive advantages across the full spectrum of technical, capital allocation, and risk considerations, including political and economic stability, technology, training, research and development, environmental and labour standards, and legal and regulatory certainty.

Accelerating global demand presents Australia with a once-in-a-generation opportunity to transition into a major processing, manufacturing and trading hub for lithium-ion batteries. Currently most of Australia's spodumene in the form of concentrate is exported to China for processing, before being then sent to Japan and Korea, where it is transformed into battery packs. These finished products are ultimately imported into Australia and other countries for a range of commercial energy-storage applications as well as consumer goods.

This report demonstrates the critical components in advanced battery production – precursor, anode, cathode, electrolyte – can be manufactured in Australia. Battery manufacturing technology central to downstream lithium processing therefore stands as the critical gap in the Australian supply chain.

Australia could host the entire production chain with investment from one of the world's patented battery cell manufacturers.

This report also provides an assessment of the competitive advantages Australia offers for investment in downstream processing of commodities and the local development of the lithium-ion battery supply chain. It also highlights the Australian Government's support for building economies of scale for products of emerging global significance and technological application that leverage Australia's competitive advantages in natural resources, processing, infrastructure, advanced manufacturing, and technology.

LITHIUM-ION BATTERIES

Lithium is the lightest known metal, and the least-dense solid element with the greatest electro-chemical potential and a very low melting point. These factors contribute to the lithium's excellent energy-to-weight performance and strength-to-weight properties which make it suitable for many metallurgical applications.²

Lithium is highly reactive in pure form, with a single valence electron that is easily given up to bond with other molecules. Lithium's very high electro-chemical potential (its willingness to transfer electrons) makes

it a powerful component of battery cells. This unique electro-chemical quality has underscored a global shift of approximately half the world's lithium into the production of lithium-ion batteries.

The current application of lithium-ion battery storage

- › More than 8 billion smartphones
- › More than 3 million electric cars currently on the road, with annual sales growth in 2017 greater than 50 per cent
- › Some 300,000 electric buses operating on regular commercial routes
- › Commercially available and operating electric aircraft, vehicle ferries, motorcycles, trucks and taxis.
- › More than 200 GWh of storage in smart phones, tablets and laptops
- › More than 15 GWh of stationary battery storage
- › More than 100 GWh of battery storage in power tools

WHAT IS A RECHARGEABLE LITHIUM-ION CELL?

All types of rechargeable lithium-ion cells comprise two electrodes separated by a (liquid or gel) electrolyte. The cathode (positive electrode) is made from a lithium-based compound. The anode (negative electrode) is generally made from carbon (graphite). The composition of the electrolyte varies from one type of battery to another.

When the battery is charging, the cathode releases lithium ions which move through the electrolyte to the anode. The battery takes in and stores energy during this process. When the battery is discharging, lithium ions move back across the electrolyte to the cathode, producing the energy that powers the battery. Unlike disposable cells, this is a reversible and not a finite process. This enables multiple charge/discharge cycles and no lithium (or other component) is consumed in the process. Chemical changes occur over time which cause the batteries to gradually lose effectiveness.

Lithium-ion batteries and future energy storage

As noted in the Australian Chief Scientist’s recent paper ‘Taking Charge: The Energy Storage Opportunity for Australia’³, the two most mature technologies for energy storage in Australia are pumped hydro and lithium-ion batteries.

Lithium-ion batteries are scalable and can be located at or near where their energy is consumed, avoiding the need for extensive electrical grid upgrades. Lithium-ion batteries have significant practical advantages over other battery sources. They have higher energy density and a longer cycle life; can charge and discharge faster than other storage alternatives; can supply applications requiring high current (such as power tools); require less maintenance; can be manufactured and deployed

faster; and can be mass produced leveraging existing technology. While other electrical storage solutions exist commercially – such as vanadium flow batteries, lead-acid batteries, salt-water batteries – none of the alternatives have the versatility of a lithium-ion battery. A typical lithium-ion battery generates around 3 volts compared to 2.1 volts for lead-acid or 1.5 volts for zinc-carbon cells.⁴

Lithium-ion battery manufacturers continue to innovate, improving performance and reducing dependence on cobalt and graphite. These evolutionary changes are expected to be implemented over the next five to 10 years. Longer-term research is focused on improving storage capacity, raising charging speeds, reducing the cost of production, and extending lithium-ion battery lifespans – recent research indicates that effective cell life could reach 20 years under regular use.

Figure 1: Lithium-ion battery consumption

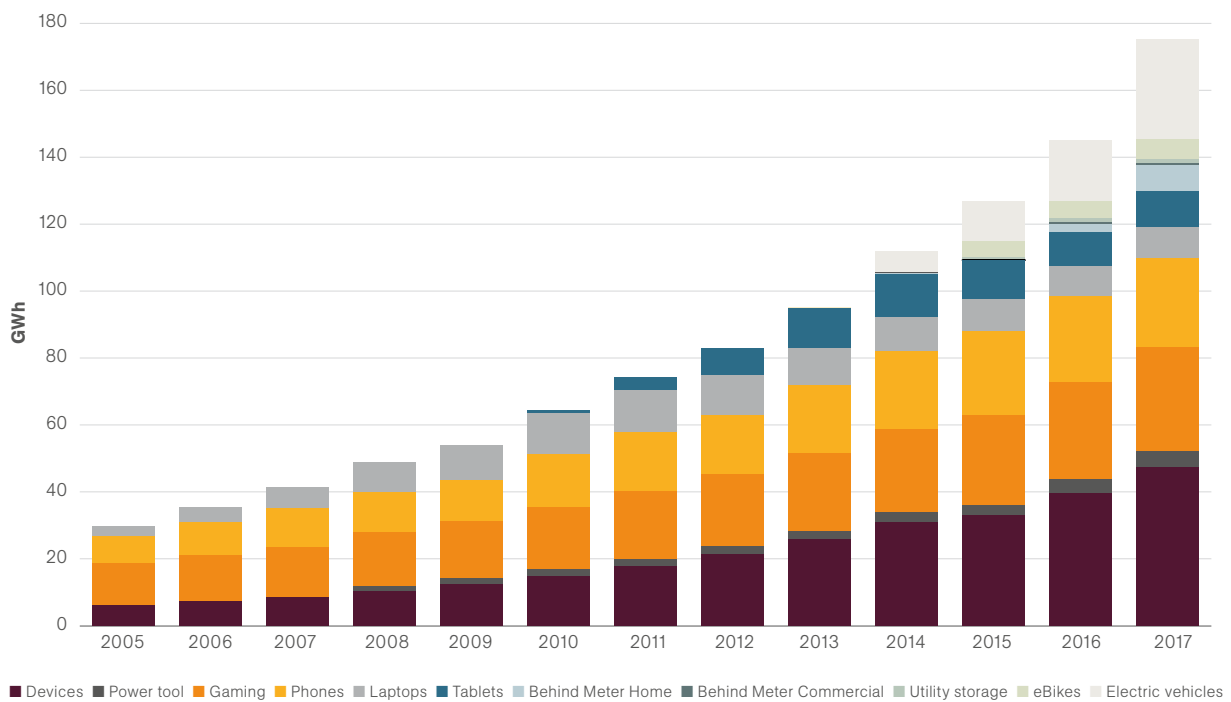

Source: Future Smart Strategies (June 2018)

Demand and price outlook

While batteries have long been included in products, demand for lithium-ion batteries has accelerated over the past decade due to their performance and grid-scale energy storage potential. Forecast growth in EVs will be a significant source of demand as governments adopt policies that encourage the move from Internal Combustion Vehicles (ICEs). Other initiatives are also fuelling demand by raising the costs of traditional energy distribution and constraining the development of non-renewable resource supplies. The full range of industry drivers for lithium-ion batteries is available at Figure 1.

Deutsche Bank expects global battery consumption to increase five-fold in the next 10 years, placing pressure on battery supply chain and lithium markets.⁵ Frost & Sullivan forecast that for the period 2017 to 2023, demand for lithium-ion batteries for EVs will increase by 32.4 per cent, grid and energy storage by 21 per cent and consumer electronic applications by 8.1 per cent.⁶ As shown in the graph below, BMO Capital Markets estimate lithium demand grew at 8 per cent compound annual growth rate (CAGR) from 2010 to 2016 and forecast a 14 per cent year-on-year growth until 2025.

Analysts expect battery demand will increase the demand for lithium from 214kt in Lithium Carbonate Equivalent (LCE) in 2017 to 535⁷ or 587⁸ LCE in 2025. McKinsey forecasts demand to grow between a base estimate of 669 LCE up to 893 LCE in 2025.⁹

World consumption of lithium-ion battery energy is expected to increase from 70 Gigawatt hours (GWh) in 2015 to approximately 535GWh by 2023.¹⁰ Deutsche Bank expects battery use in energy storage will rise to 50GWh per annum by 2025 (46 per cent CAGR over next 10 years). Deutsche Bank also forecasts lithium-ion batteries will account for 97 per cent of battery use in energy storage alone by 2025.¹¹

The increased use of lithium-ion batteries across a range of applications will create economies of scale and technological advancements which are expected to drive lower battery unit costs. Deutsche Bank estimates lithium-ion battery costs could fall to US\$150/kilowatt hour (kWh) by 2020 as multinational companies further expand global battery manufacturing capacity.¹² Frost & Sullivan expect the price of lithium-ion batteries to fall to US\$200/kWh by 2023, driven by promising growth in the electric vehicle segment.¹³

Figure 2: Forecast global annual lithium demand

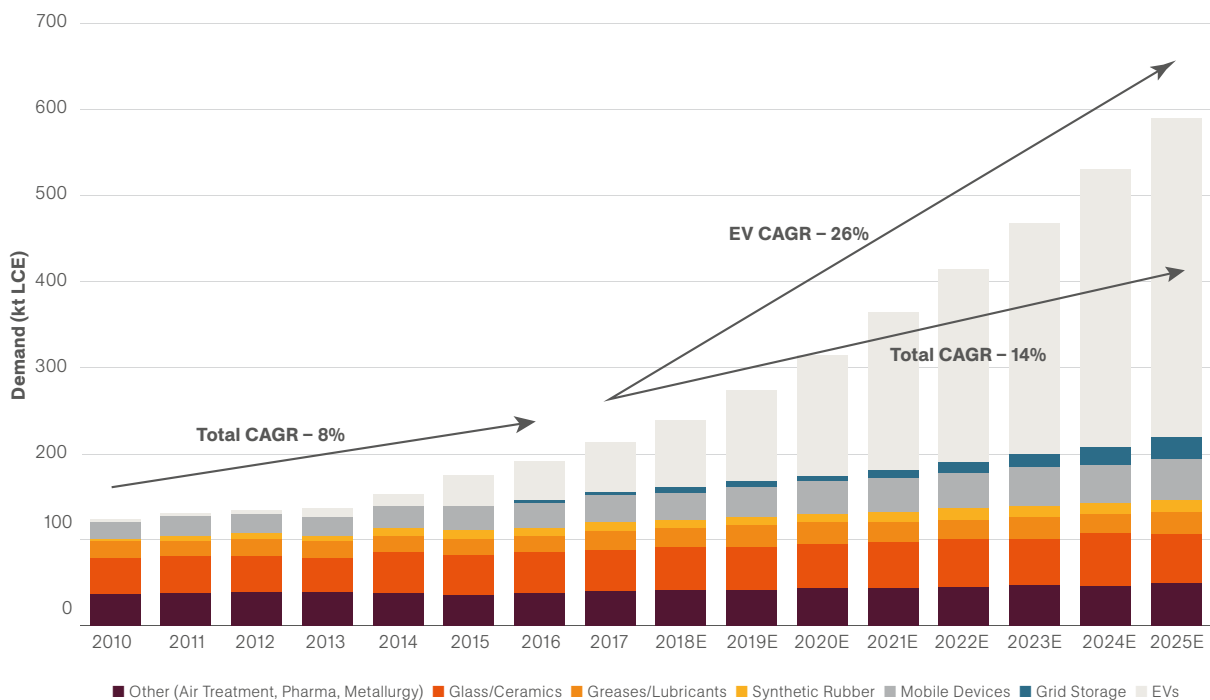

Source: Industry Reports, BMO Capital Markets

Figure 3: Falling price of batteries by category

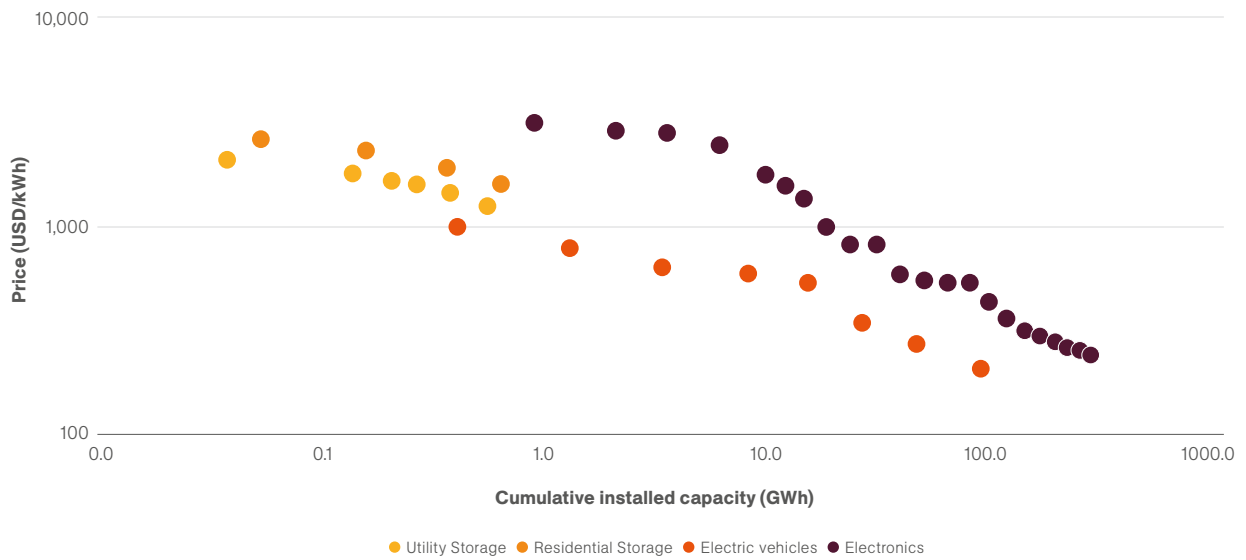

Source: IEA Global EV Outlook 2018 report

Production forecasts

The lithium-ion battery manufacturing industry is adding additional capacity to meet the rise in global demand. Future Smart Strategies' projections (below), at the top end of available forecasts, are based on announcements of new factory construction and commitments by leading industry participants.¹⁴ Financial commitments beyond five years are

uncommon and longer-term forecasts are based on anticipated plant capacity. In addition to the forecasts in Figure 2, Benchmark Mineral Intelligence believes lithium battery manufacturing capacity could grow to 1,043GWh by 2028 (840kt LCE) with 45 different battery facilities in development.¹⁵ At the same time, demand pressures and greater efficiencies are driving lower production costs (see Figure 3), while major industry participants ramp up production (see Figure 6).

Figure 4: Comparative forecast global annual battery production (GWh) to 2023

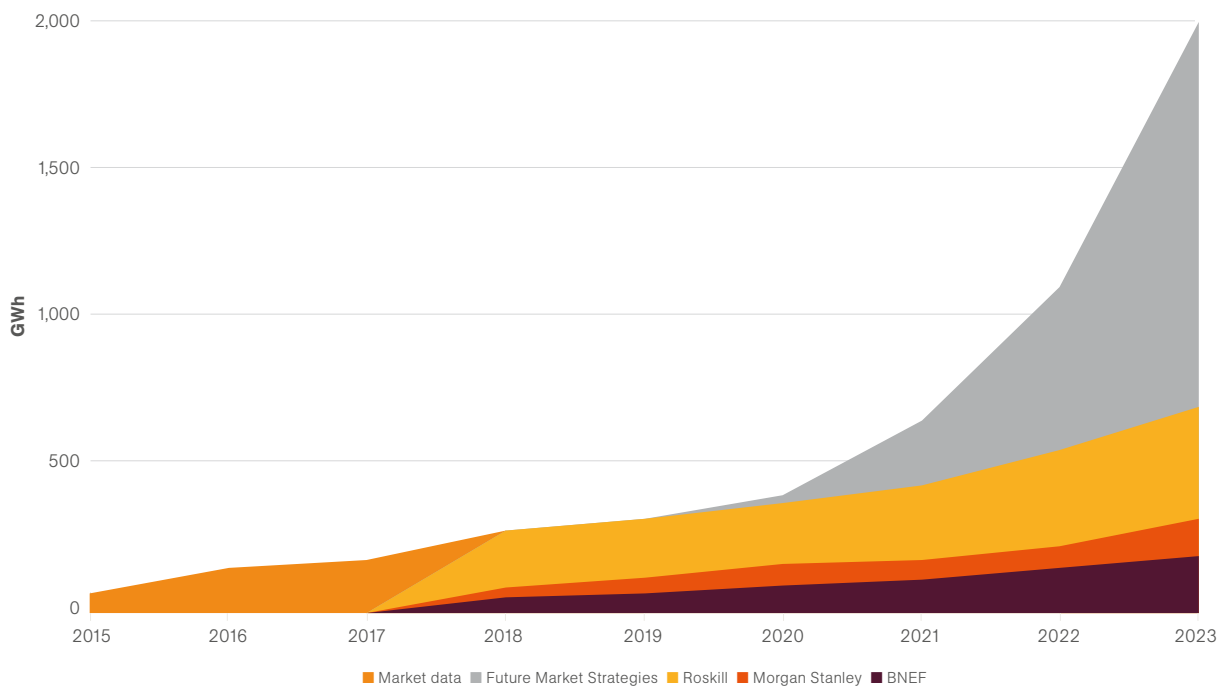

Source: Future Smart Strategies (June 2018)

Figure 5: Forecast global production capacity for existing and committed projects to 2023

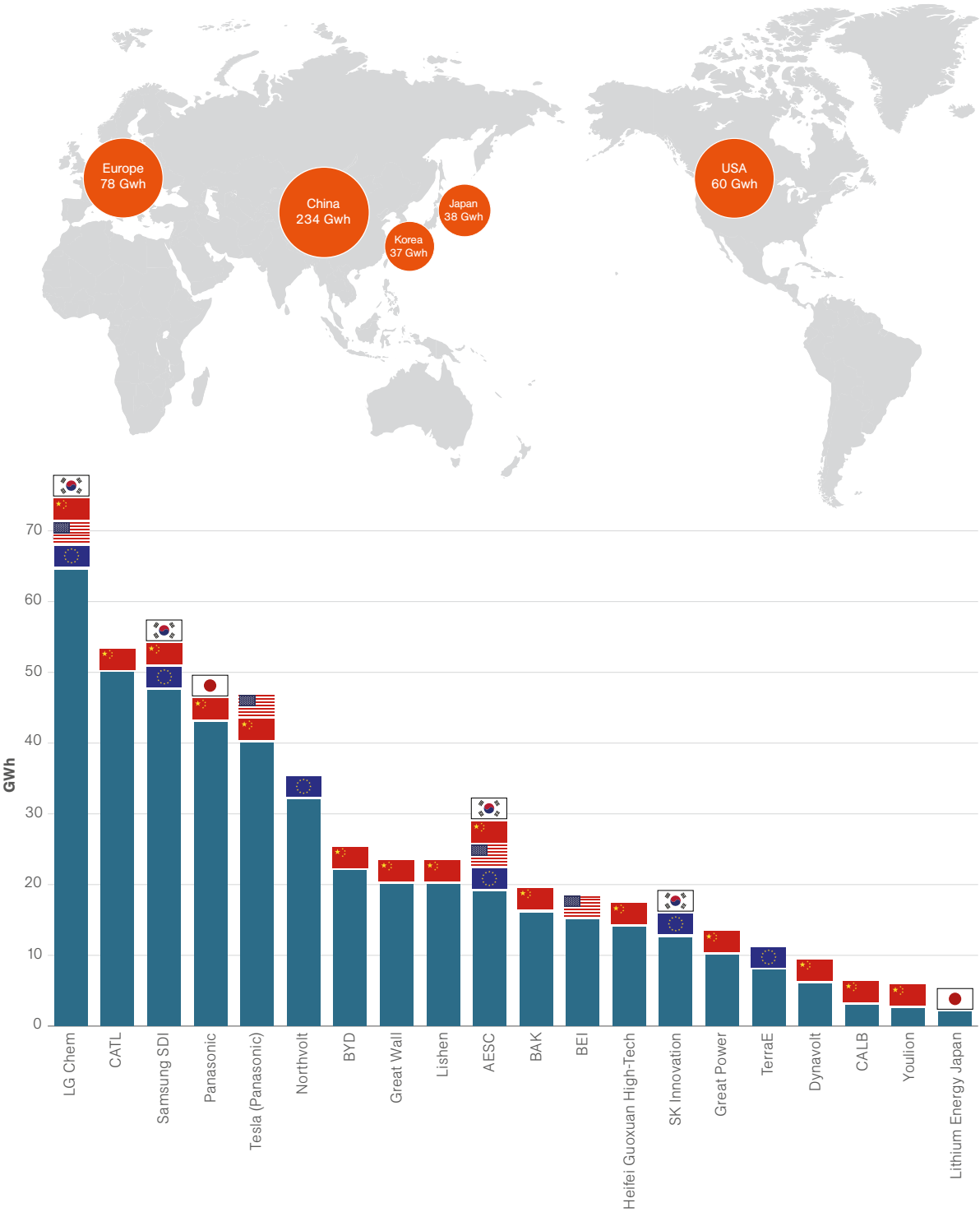

Source: Future Smart Strategies (June 2018) and Benchmark Mineral Intelligence 2018

Figure 6: Planned production capability of major producers

Company	Planned GWh by 2020
Tesla	150
CATL	88
Panasonic	80
BYD	60
LG Chem	20
Foxconn	16
Daimler	15
Boston Power	10
Other	26
TOTAL	465

Source: Future Smart Strategies (June 2018). The above table is based on announced planned production capacity for battery factories in 2020 (collected media reports as at 30 June 2018).



FROM LITHIUM SPODUMENE TO BATTERY PACKS: HOW LITHIUM-ION BATTERIES ARE PRODUCED

Lithium ore

Lithium is extracted from lithium minerals found in igneous rocks composed of large crystals (spodumene) or in water with a high concentration of lithium carbonate (brine). Historically global lithium supply was dominated by hard-rock mineral sources. However, in the early 1980s, large-scale lithium brine operations commenced in South America. Today, the world's lithium production is split evenly between hard rock and brine.

Most of Australia's lithium resource is contained in hard-rock spodumene deposits. Australian technical expertise has enabled producers to scale up quickly and competitively. Australia supplied more than half the world lithium market in 2017. As global lithium demand increases, hard-rock operations will continue to respond to market conditions much faster than their brine counterparts.¹⁶

Processing spodumene deposits follows conventional hard-rock mining and processing practices. Ore is mined via drill and blast methods, then excavated and trucked to a central processing facility. The ore then undergoes multiple stages of crushing to reduce the particle size to below 6mm. Following flotation and magnetic separation, the wet concentrate is filtered and prepared for transportation as a six per cent Lithium Oxide (Li_2O) concentrate.

Lithium brine is concentrated by solar evaporation from soluble salts. Capital input for producing lithium from brines is high but subsequent operating costs are comparatively low. While less expensive to mine than rock, lithium extraction from brine can take 12 to 18 months to reach extraction levels. Project scale up usually takes between eight to 10 years for brine compared to two to three years for spodumene.

Processing

Lithium is typically marketed in the form of lithium carbonate (Li_2CO_3), lithium hydroxide (LiOH) or lithium chloride (LiCl). Lithium products derived from brine operations can be used directly in end-markets, but hard-rock lithium concentrates must be further processed before they can be used in value-added applications like lithium-ion batteries. Most of Australia's lithium is exported overseas as a bulk concentrate for further processing. Generally Australian shipments contain only six per cent Li_2O concentrate.

China dominates lithium processing, accounting for an estimated 89 per cent of the world's lithium hydroxide.¹⁷ Chinese refineries produce lithium carbonate, lithium hydroxide and lithium chloride – the precursors to lithium-ion battery cathode materials. They are chemically stable (for storage and transport), contain a high proportion of lithium, and can be readily transformed into a lithium compound for cathode building.

Australia has attracted investment from two of the world's largest lithium producers – Tianqi (China) and Albemarle (US). These companies are both investing in downstream lithium processing at Kwinana and Kemerton in Western Australia. There are three processing plants in development phase in Western Australia.

► **Tianqi (Kwinana):** Tianqi is constructing a two-stage lithium processing plant in Kwinana, Western Australia at a cost of \$A700 million. Construction began in October 2016 and is scheduled for commissioning towards the end of 2019. The project is expected to create 500 local construction and 175 full-time production jobs at completion of the first stage at end 2018. Once complete, the

Figure 7: From lithium extraction to battery cell manufacturing

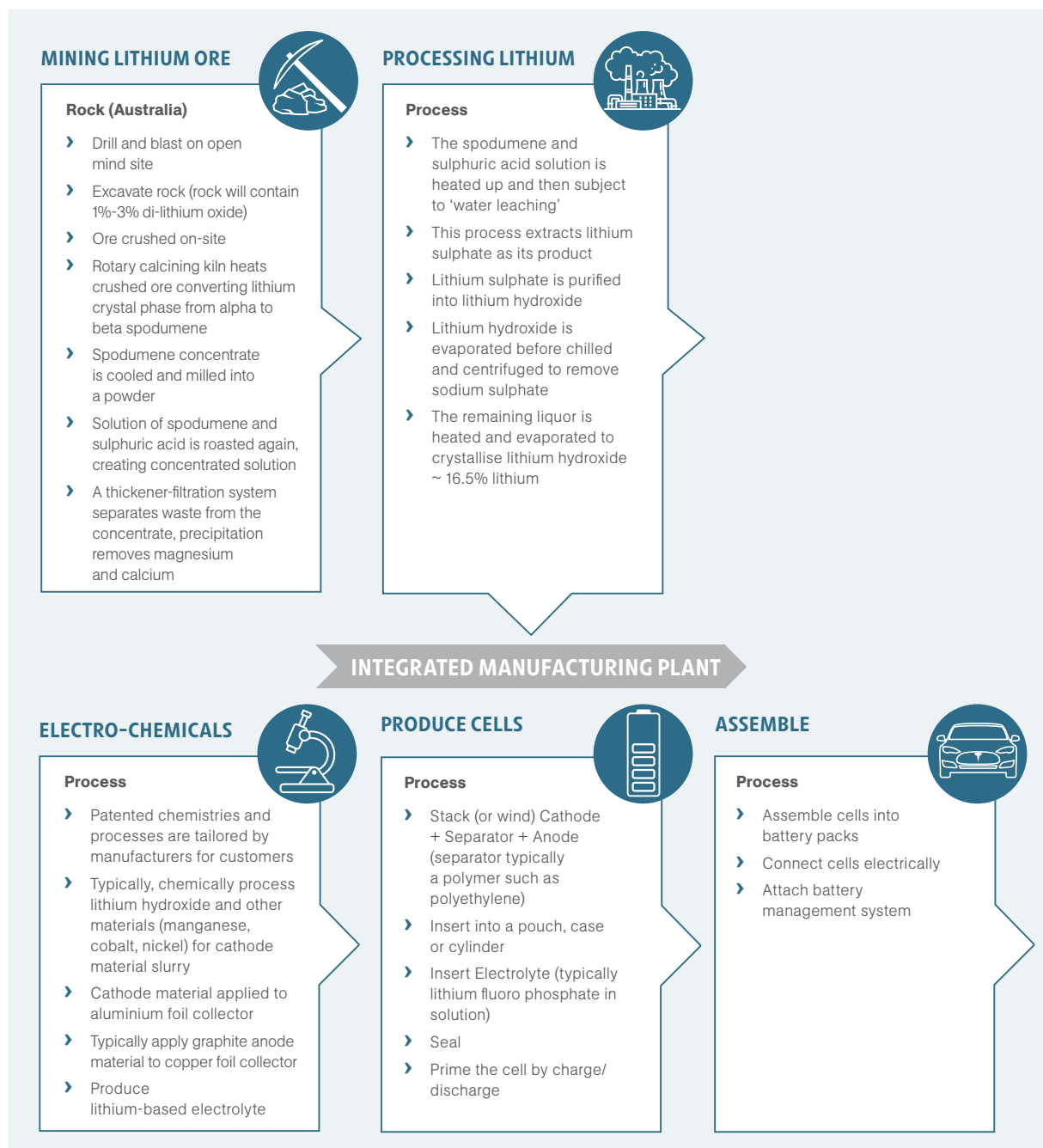

Source: Future Smart Strategies (June 2018)

Kwinana plant will have a capacity of 48,000 tonnes per annum of high purity, battery-grade lithium hydroxide.

- › **Albemarle (Kemerton):** Albemarle has received final regulatory approval for its plans to develop a lithium hydroxide processing plant at the Kemerton Industrial Park, near Bunbury. Albemarle aims to process spodumene ore concentrate from the Talison Greenbushes mine to produce 100,000tpa of lithium hydroxide by 2025.

- › **Covalent Lithium (Kwinana):** Kidman Resources and Chile-based Sociedad Quimica y Minera de Chile (SQM) have a 50:50 joint venture to develop and operate the Mt Holland lithium project as well as a proposed downstream lithium processing facility. The companies expect to produce 44,000tpa of lithium hydroxide in 2021, 37,800tpa of lithium carbonate, or a combination of both. The project is expected to create 700 full-time jobs (400 at the refinery) during construction and 300 (150 at the refinery) during operations.

Figure 8: The Lithium-ion battery industry chain

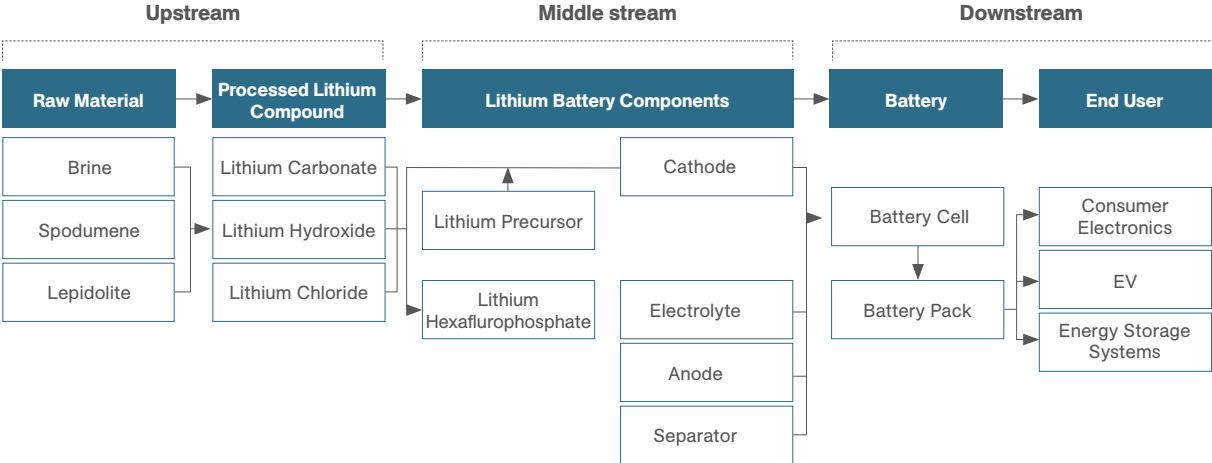

Source: Deutsche Bank

Battery manufacture

Lithium-ion battery cells comprise a cathode (positive electrode), anode (negative electrode) and electrolyte solution. The cells also contain separators which prevent the battery from short circuiting and overheating. The separator also functions as a conduit for lithium-ion flow by maintaining the electrolytic solution. At the conclusion of the production phase, lithium-ion batteries are placed in packs which contain modules connecting battery cells to management systems.

There are six different types of lithium-ion battery. The three chemistries most commonly used in battery production are: lithium iron phosphate (LFP); lithium nickel cobalt aluminium oxide (NCA) and lithium nickel manganese cobalt oxide (NMC). The remaining three are: lithium cobalt (LCO); lithium manganese oxide (LMO); and lithium titanate (LTO) – which offers an alternative anode composition. This report focuses on the three main chemistries used in lithium-ion battery production – LFP, NCA and NMC.

The lithium-ion battery industry focuses closely on the purity and quality of the cathode as it represents 22 per cent of battery costs and is essential to determining battery performance. To ensure quality performance, LG Chem, Panasonic and BYD Batteries have started in-house cathode manufacturing production facilities through backward integration.¹⁹

South Korean and Japanese companies are the leading established producers of lithium-ion batteries. Major lithium battery manufacturers are traditional electrical appliance producers, such as Panasonic, BYD, PEVE (a

LITHIUM-ION BATTERY CHEMISTRIES

LFP is used in Chinese EVs because of the availability of iron to Chinese manufacturers. LFP is known for its stability/safety and capacity compared to other cathode chemistries. Increasingly Chinese EVs manufacturers are looking to switch to other cathodes with better energy density.

NCA is similar to NMC chemistries and is used in Tesla/Panasonic batteries. This composition is more expensive and less safe, which make it less attractive to the wider EV market.¹⁸

NMC is the current focus of battery designers and researchers by virtue of its performance-enhancing properties. The aim is to reduce cobalt content due to high international cobalt prices. While higher nickel content increases energy density, it also becomes less stable as cobalt stabilises nickel.

LCO batteries are used in laptops, tablets and smart phones. These cathodes are limited by low thermal stability (which reduces its safety) and high cost. They are not used in EV batteries because they are more expensive and not as safe as other options.

LMO are generally much safer than other cathodes but have a shorter lifespan. They are usually blended with NMC chemistry of aluminium.

Figure 9: EV Battery Chemistry Market Share

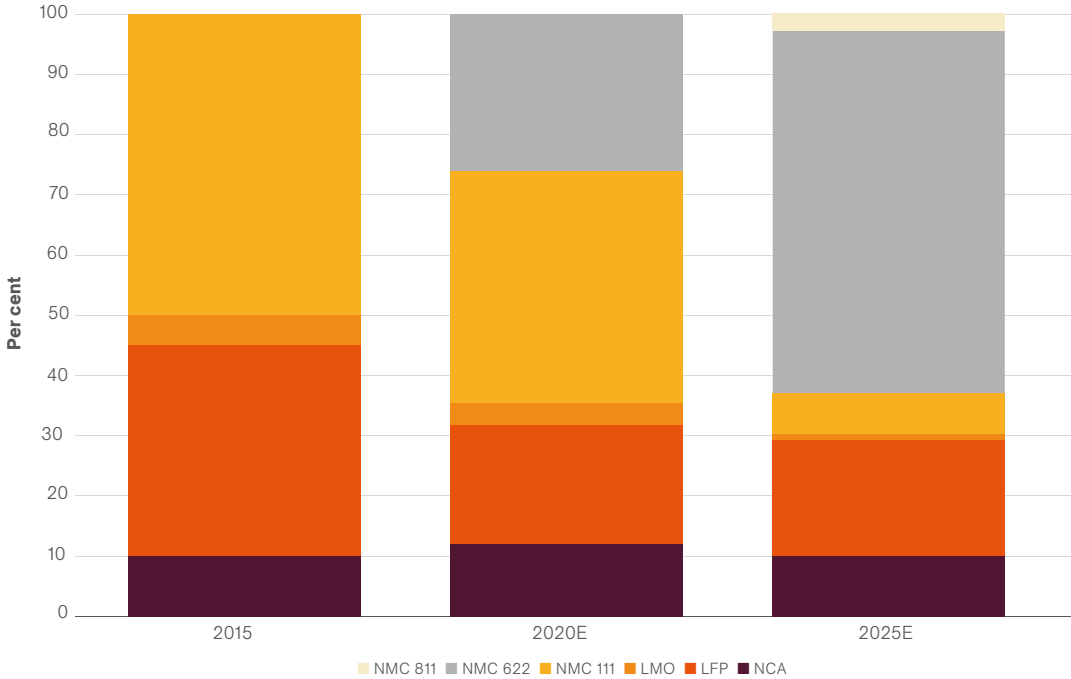

Source: BMO Capital Markets

joint venture between Panasonic and Toyota), AESC (a joint venture between NEC and Nissan), LG Chem, and Samsung SDI. The bulk of their manufacturing comes from integrated manufacturing plants satisfying both volume and quality expectations.

While much of the manufacturing technology has been developed in Korea and Japan, China has moved to establish its own battery cell capability, utilising its comparatively small lithium ore reserves, its dominant market position in lithium refining, and its proximity to centres of high demand. This strategy is supported by Korean and Japanese investment, as well as Chinese companies emulating foreign technology and processes. Figure 10 shows the share of each country in the lithium-ion battery supply chain.

China is moving up the value-add curve through its closer focus on automation and integration into lithium-ion battery manufacturing supply chains. As lithium-ion battery demand has risen, China’s manufacturing economies of scale (resource supply, labour costs, supportive government policies and a nascent electric vehicle sector) have increased. China is however increasingly dependent on the imported critical materials, including lithium concentrate or unprocessed ore.

The US and several European countries have recently started to upscale their lithium-ion battery manufacturing capacity in response to increased demand for EVs. US and European-based plants have cloned Korean and Japanese chemistries, technology and manufacturing expertise to produce batteries in close proximity to EV plants.

In addition to the chemistry of cathodes, the current production trend is ‘gigafactories’. The number of lithium-ion battery gigafactories has risen from three planned in 2015 to 42, with 19 of those in China.²⁰ Tesla, through its partnership with Panasonic, produces 20GWh at its Gigafactory No 1 in Nevada. Tesla plans to increase production to 35GWh by 2025. Companies are also aiming to compete by integrating internally vertical up-stream battery material production.

Germany is progressing plans to build a facility known as Terra-E, with a consortium of 17 companies aiming to construct a 34GWh plant by 2028. German Chancellor Angela Merkel is supporting the development of a strategic ability to produce battery cells. Germany recently proposed two large-scale construction projects and plans to build mass-production facilities. Some €600 million has been slated for a research factory, together with the Fraunhofer Association, to support future battery cell development and innovation.

Figure 10: Share of the lithium supply chain by country 2017



Source: A Lithium industry in Australia: A value chain analysis for down streaming Australia's lithium resources. Association of Mining and Exploration Companies, 2017.



HOW COMPETITIVELY PLACED IS AUSTRALIA TO OWN THE SUPPLY CHAIN?

Mineral resources

Australia has a comparative advantage in its access to the mineral elements required for lithium-ion battery production. Australia has world’s third-largest reserves of lithium and is the largest producer of hard-rock lithium spodumene. Australia also currently produces nine of the 10 elements required to produce most lithium-ion battery anodes and cathodes, and has commercial reserves of graphite – the remaining element.²¹ Australia also has secure access to all of the chemicals required for lithium-ion battery production.

Australia’s resource base and production

Australia’s lithium resource base (over 18 per cent of the world’s economic resources)²² ranks third globally, behind Chile and China. Australia’s economic demonstrated resources (EDR) of lithium in 2016 stood at 2730kt, up from 1610kt in 2015. Talison’s Greenbushes project, the world’s largest and highest-grade spodumene deposit, contains 50 per cent of Australia’s lithium EDR. Other significant resources include Mount Cattlin, Mount Marion and Earl Grey in the Yilgarn region and the two Pigangoora deposits in Western Australia.²³

LITHIUM

Figures 11 & 12: Lithium reserves and production by country

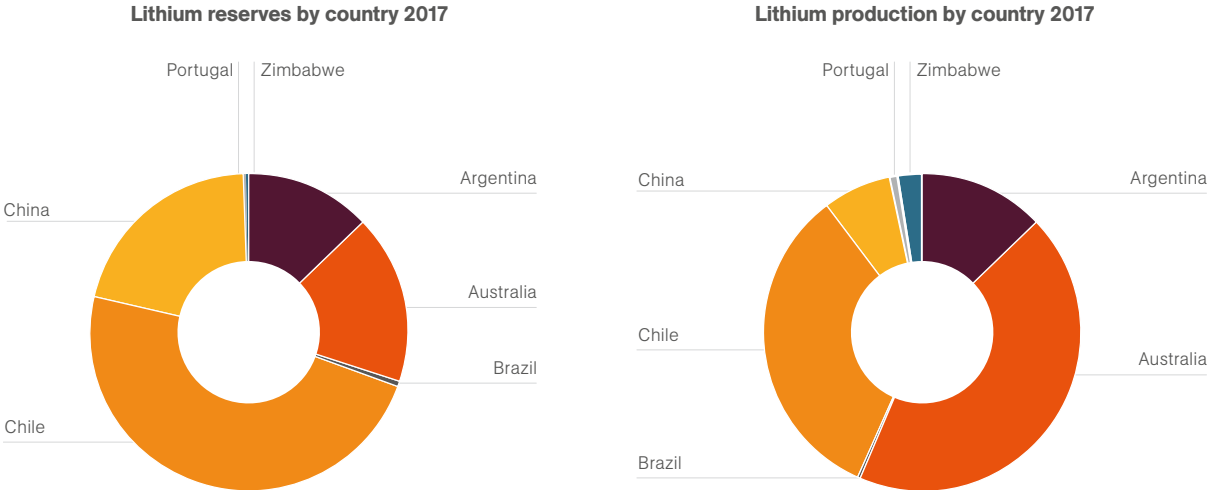

Source: USGS (2018)

Australia was the world's largest producer of lithium in 2017, with an output of 14,300mt, equivalent to 76,199mt lithium carbonate,²⁴ equivalent to 43 per cent of global lithium output. Production in Australia increased by approximately 34 per cent in 2017 as two new spodumene operations increased their concentrate production. Australian exports of spodumene ore have risen from around \$A117 million in 2012 to \$A780 million in 2017, and are expected to rise to around \$A1.1 billion by 2020.

Australia is developing its lithium extraction capacity faster than any other country. Forecast output from existing Australian operations and planned projects tracked by the Western Australian Department of Mines indicates a potential supply of more than 1mt LCE by the early 2020s.²⁵ This projection indicates underlying industry demand for lithium at a higher rate than forecast by many industry analysts. For example, McKinsey & Company forecast only 669,000 tonnes of global LCE demand in 2025.²⁶

Summary of current Australian lithium projects (as at September 2018)

- ▶ Talison Lithium operates the world's largest lithium mining project – the Greenbushes mine near Bunbury (250km south of Perth) in Western Australia. Greenbushes satisfies approximately one-third of current global lithium demand. The company has board approval for an additional \$A516million to expand the project, which is expected to double lithium concentrate production to 1.95mt (520,000tpa LCE). The Greenbushes project has two processing plants which produce different lithium concentrates to meet specific customer requirements: one producing technical-grade lithium concentrates with a low iron content; the second producing high yielding chemical-grade lithium concentrate used to produce lithium chemicals used in the manufacture of lithium-ion batteries.²⁷
- ▶ The Mt Cattlin Mine, operated by Galaxy Resources and located near Ravensthorpe in Western Australia, commenced production in 2016. Estimated reserves are 11.62mt with a grade of 1.20 per cent lithium oxide. At full capacity, ore can be processed at a rate of 1.6mtpa, with production of spodumene concentrate at 180,000tpa. Bulk concentrate is shipped directly to China from the Esperance Port in Western Australia.²⁸
- ▶ The Mt Marion Mine, 40km south west of Kalgoorlie, began production in 2016. This project is jointly owned Mineral Resources Limited (Australia: 43.1 per cent), NeoMetals (Australia: 13.8 per cent) and Jiangxi Ganfeng Lithium (China: 43 per cent). The estimated reserves are 77,800kt with lithium oxide grade of 1.37 per cent providing for a 2,700kts of LCE.²⁹ Production is expected to be 400,000tpa.
- ▶ The Earl Grey lithium project in Mt Holland, 370km east of Perth, is being developed by Kidman Resources (Australia: 50 per cent) and Sociedad Química y Minera (SQM, Chile: 50 per cent). This deposit is estimated to hold 189mt of spodumene at 7.03mt of LCE. Kidman Resources expects the project to create 300 full time operational jobs and supply up to \$1.7 billion in royalties to the Western Australian Government.
- ▶ The Pilgangoora deposit, 120km south of Port Hedland, is 100 per cent owned by Pilbara Minerals. Estimated reserves are 226mt with a lithium oxide grade of 1.27 per cent.³⁰ At full capacity, the project is forecast to produce 800,000tpa of spodumene concentrate. Production commenced in 2018, followed by a first shipment of 8,800t of spodumene concentrate in September 2018. The company has offtake agreements with China's General Lithium and Jiangxi Ganfeng Lithium. In November, the Pilbara board approved a second-stage expansion of the Pilgangoora project, which will see an additional 3mtpa processing circuit added to the existing operation, taking the project capacity to 5mtpa. The expansion will increase production from 314,000tpa, to between 800,000 tpa and 850,000tpa of spodumene concentrate over a forecast 17 year mine life.
- ▶ A similarly named Pilgangoora Project, being developed by Altura Mining, commenced production in July 2018. The company is considering a feasibility study to double production. Estimated reserves are 30,100kt with a lithium oxide grade of 1.04 per cent for a total 774kt of LCE. Project owners hope to produce approximately 230,000 tpa of lithium spodumene concentrate.
- ▶ The Bald Hill lithium and tantalum mine is a joint venture between Tawana and Alliance Minerals. Estimated reserves are 18,900kt with a lithium oxide grade of 1.18 per cent for 551kt of LCE. Lithium concentrate production commenced in March 2018.

- ▶ Mineral Resources' Wodgina deposit is 100km south of Port Hedland in Western Australia. The mine began exporting Direct Shipping Ore (DSO) in April 2017 to provide cash flow to fund construction a spodumene concentrate plant which will produce 750,000tpa of 6 per cent spodumene concentrate. The estimated resource is 198,000kt with lithium oxide grade of 1.18 per cent and 5,777kt of LCE.³¹ On 21 November 2018, Albemarle announced that it had signed an Exclusivity Agreement with Mineral Resources in

relation to the potential creation of a 50/50 joint venture to own and operate the Wodgina hard rock lithium mine and ultimately develop an integrated lithium hydroxide operation at the resource site.

- ▶ Core Exploration is developing the Finiss Lithium Project south of Darwin in the Northern Territory. The estimated resource is 3.45mt with a grade of 1.4 per cent. Core has an offtake agreement with China's Yahua. First deliveries are scheduled for late 2019.

COPPER

Copper is commonly used as the collector for the anode electrode in a lithium-ion battery across each of the chemistry applications assessed in this report.

Figures 13 & 14: Copper reserves and production by country

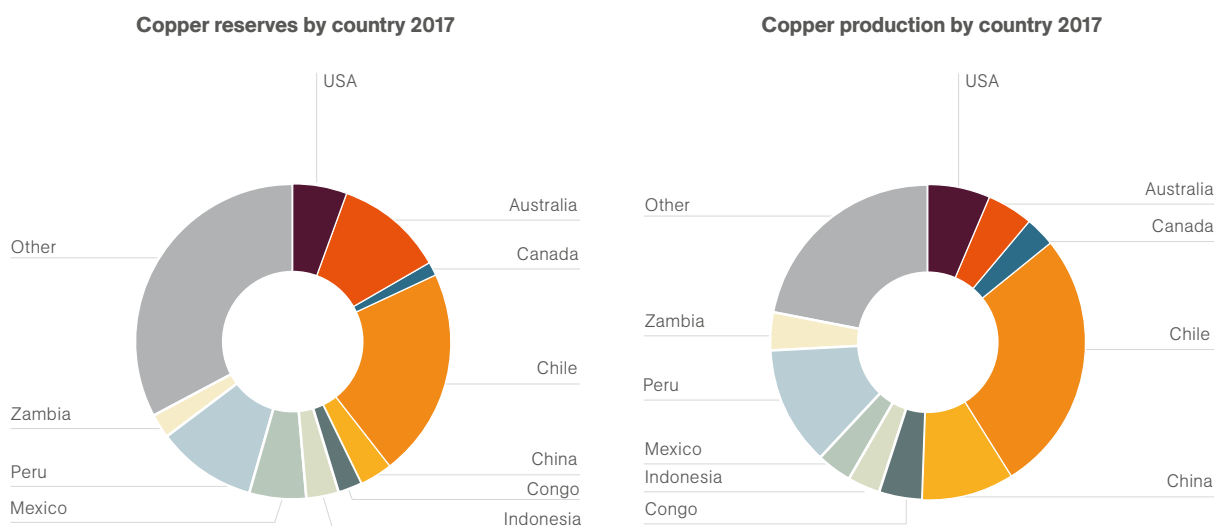

Source: USGS (2018)

Australia's resource base and production

Australia is the seventh-largest producer of copper in the world and third-largest exporter of copper ores and concentrates. Australian copper reserves could last more than 90 years.³² Copper is mined in all Australian states and the Northern Territory, with most production coming from major mines in the Mount Isa region in Queensland and at the Olympic Dam mine in South Australia.³³

BHP BILLITON

BHP Billiton's Olympic Dam is the fourth-largest copper resource in the world. Olympic Dam operates a fully integrated processing facility from ore to metal.³⁴ Glencore operates Australia's two deepest underground copper mines and has a world-leading electrolytic copper refinery, producing 275,750 tonnes of copper metal and 53,900tpa of copper concentrate. Oz Minerals' Prominent Hill project in South Australia's Gawler Craton Region is another major operating copper mine.

NICKEL

Nickel is a key input for cathode electrodes used in NMC and NCA chemistries. Demand for nickel is rising in response to accelerating lithium-ion battery demand, and the transition towards higher nickel/lower cobalt proportions in both NMC and NCA chemistry formulations.

Figures 15 & 16: Nickel reserves and production by country

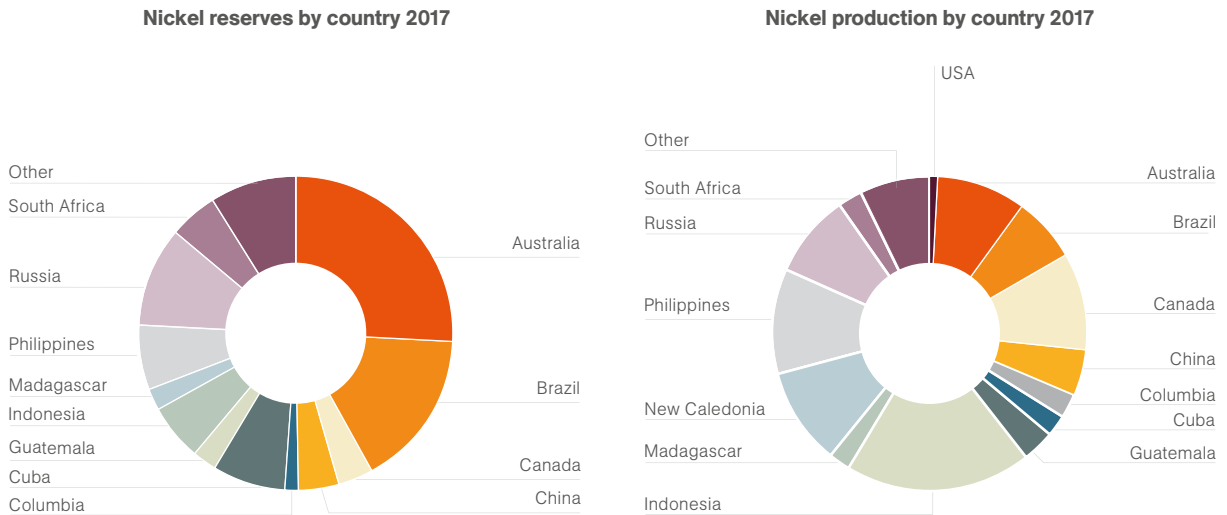

Source: USGS (2018)

Australia's resource base and production

Australia accounts for 10 per cent of global nickel production. Western Australia holds the largest nickel resources with 95.3 per cent of total Australia's EDR. Queensland is the second-largest with 4.5 per cent, followed by Tasmania with 0.2 per cent. Western Australian resources comprise both sulphide and laterite deposits. Australia's mined nickel output is forecast to rise to 178,000mt in FY2019-20, driven mainly by the startup of new mines. Australia also has significant downstream processing capabilities. Australia is forecast to produce 141,000mt of refined nickel in 2019-20, up from estimated output of 122,000mt in 2018-19. The revised forecast is largely attributed to a projected rise in output from BHP's Kwinana plant.

BHP SNAPSHOT

The Kalgoorlie Nickel Smelter, part of BHP's Nickel West Operation, is one of the largest nickel matte producers in the world, with a capacity of 110ktpa. The smelter receives concentrates from nickel mines at Kambalda and Leinster and is connected to the Kwinana Nickel refinery via rail. Kwinana Nickel is one of the largest producers of finished nickel in the world (capacity of 65ktpa) and also produces mixed nickel and cobalt sulphide, copper sulphide and ammonium sulphate. The smelter also produces some 550ktpa of sulphuric acid.³⁵

BHP's Nickel West project has funding and government approval for phase one of its nickel sulphate project, which will be the largest nickel sulphate project in the world. The project will produce 100ktpa of nickel sulphate hexahydrate in phase one with the second phase doubling production by dissolving nickel powder at Kwinana Nickel Refinery in sulphuric acid from its Kalgoorlie Smelter. Nickel West can also produce cobalt sulphate as a by-product.

COBALT

Cobalt is used in the cathode material for NMC, NCA and LCO chemistries. Cobalt is mined independently or as a by-product of nickel and copper production. Cobalt prices have been volatile throughout 2018, driven by market sentiment around the battery market. Efforts are underway to reduce the proportion of cobalt used in lithium-ion batteries. Pressure is also mounting on battery manufacturers to source cobalt from suppliers with strong corporate social responsibility commitments.

Figure 17 & 18: Cobalt reserves and production by country

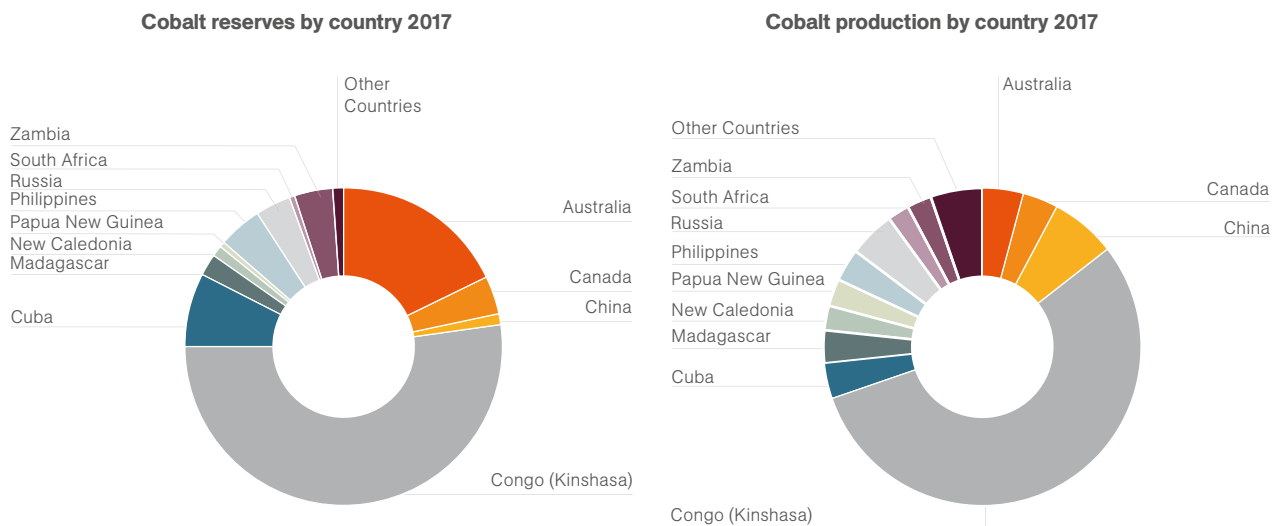

Source: USGS (2018)

Australia's resource base and production

Australia is ranked second for global cobalt resources and has 14 per cent of world resources. In terms of production, Australia is ranked fifth, accounting for 4 per cent of global production, significantly behind the Democratic Republic of the Congo (over 50 per cent of both reserves and production in 2017).³⁶

Copper and nickel plants also process cobalt. With shifting demands for critical elements, some companies are extracting cobalt from tailings to improve the economics and utilisation of existing plant infrastructure.

CLEAN TEQ

Clean Teq is planning to produce 4,000-5,000tpa of cobalt over the next two to six years through the development of its Sunrise Nickel-Cobalt-Scandium Project in Parkes, New South Wales. A Definitive Feasibility Study (DFS) was completed in June 2018, which highlighted the project's global importance as a sustainable, long-life, low-cost source of high purity cobalt and nickel sulphates.

MURRIN MURRIN

Minara's Murrin Murrin nickel cobalt operation in Western Australia, owned by Glencore, is one of Australia's top nickel producers.³⁷ Conventional open pit mining techniques are used, followed by ore processing comprising pressure acid leaching, mixed sulphide precipitation, cobalt refining and nickel refining. The production process also produces ammonium sulphate as a by-product. Through its research and development program, Minara has used technological improvements and engineering solutions to improve plant reliability and throughput and to increase nickel and cobalt production levels. This includes Minara's research into heap leaching technology which offers the opportunity to exploit low-grade ores in a cost-effective manner.

COBALT BLUE

In September 2018, Cobalt Blue announced a bankable feasibility study for its Thackaringa cobalt project in New South Wales, which is expected to be completed by 30 June 2019. A final investment decision is due by mid-2020.

GRAPHITE

Graphite is commonly used for anodes in most lithium-ion battery chemistries, with the grade and purity of significant importance. Refining graphite into a battery-ready product typically involves proprietary processes for spheroidisation and coating, and usually occurs close to (or integrated into) battery cell production. Different crystalline structures of carbon lattice are proposed for future use (including nano-diamond and graphene). Synthetic graphite represents roughly 50 per cent of the graphite used in lithium-ion batteries.

Figures 19 & 20: Graphite reserves and production by country

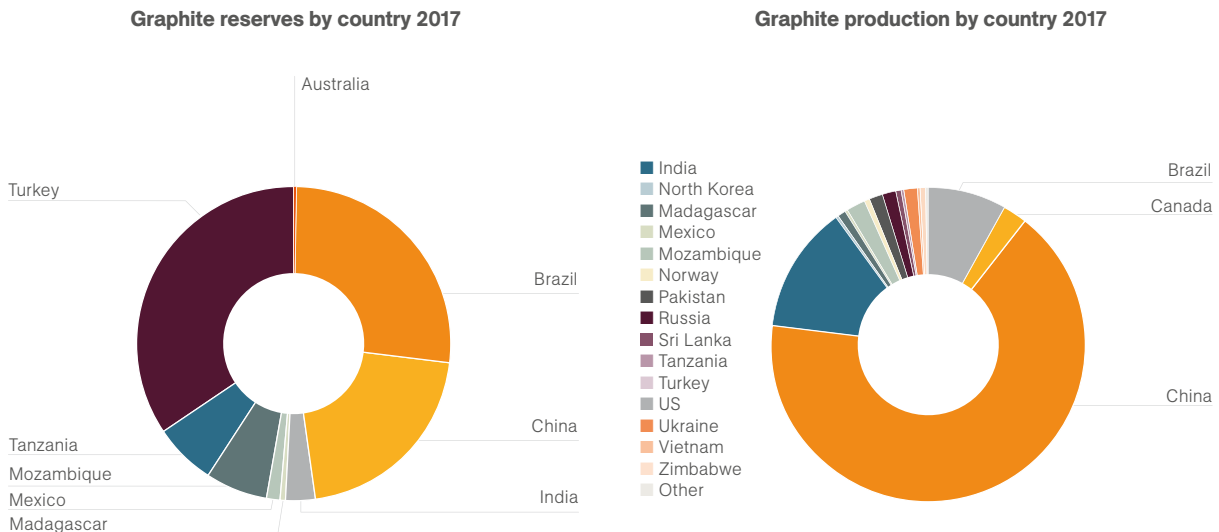

Source: USGS (2018)

Australia's resource base and production

Australia's known economic graphite reserves stand at around a modest 1,079kt³⁸ and there are no operating graphite mining projects. Lincoln Minerals is a major mineral acreage holder on South Australia's Eyre Peninsula.³⁹ Lincoln's principal graphite projects include the Kookaburra Gully Project, the Koppio Graphite Mine and the Kookaburra Gully Extended, Pernella, Campoona Syncline and Gum Flat prospects. In December 2013 Lincoln announced a maiden JORC Mineral Resource of 2.20mt with a grading 15.1 per cent total graphitic carbon (TGC) at its flagship Kookaburra Gully project. The company's primary focus includes enhancing its graphite resources and obtaining all government approvals.

Renascor has acquired the rights to the Siviour graphite project, also on South Australia's Eyre Peninsula, one of the world's largest reported graphite deposits with an average resource estimate of 80.6 million tonnes at 7.9 per cent.⁴⁰ Renascor has completed a scoping study based a 20-year mine life, at an annual production rate of 123,000tpa. The potential to produce spherical

graphite will be considered in further studies. A range of other projects are currently being progressed, with studies underway at sites in Oakdale in South Australia, and McIntosh in Western Australia.⁴¹

SYRAH RESOURCES

Syrah Resources is an Australian-based industrial minerals and technology company. Syrah first produced natural flake graphite at the Balama graphite project in Mozambique in November 2017. Once at full capacity, Balama will be the leading global producer of high purity graphite. Syrah tests Battery Anode Material (BAM) product samples at a pilot plant in China and is also developing a 60ktpa capacity BAM plant in Louisiana, USA. The company also plans to establish a technology centre in Perth for process training, product optimisation and research and development.⁴²

MANGANESE

Manganese is a component of the cathode material based on NMC and LMO chemistries.

Figures 21 & 22: Manganese reserves and production by country

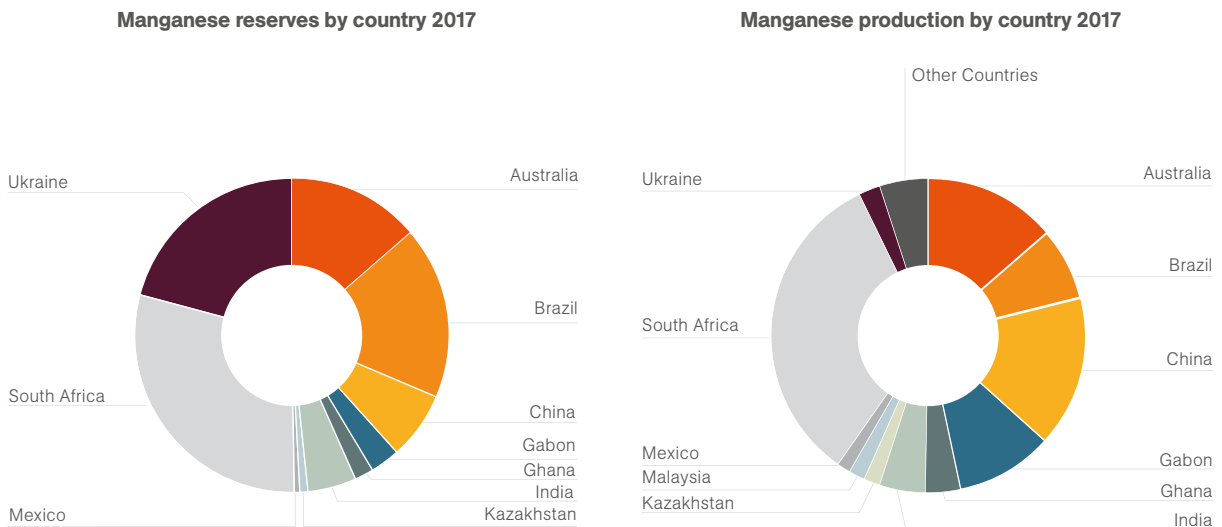

Source: USGS (2018)

Australia's resource base and production

Australia's manganese resource base (219mt in 2016) is ranked fourth globally behind South Africa, Ukraine and

Brazil. All reserves are located in the Northern Territory and Western Australia with a production of 3.2mt in 2016.⁴³

SNAPSHOT OF AUSTRALIA'S MANGANESE PROJECTS

GEMCO's Groote Eylandt mine in the Northern Territory (60 per cent South32 and 40 per cent Anglo American) is one of the largest manganese producers in the world. The company is expected to produce 5.2mt of manganese ore in 2017-18, up from 4.9mt in 2014-15. GEMCO exports approximately 90 per cent of its output, with the balance transported to GEMCO's wholly-owned manganese alloy plant, Tasmanian Electro Metallurgical Company (TEMCO) in Bell Bay, Tasmania.⁴⁴

TEMCO commenced operations in 1962 and runs the only manganese ferroalloy plant in Australia. It incorporates four furnaces and a sinter plant and produces high-carbon ferromanganese, silicomanganese and sinter. TEMCO has become an efficient, low cost, world-class producer of manganese alloys with some 75 per cent of its production exported to more than 50 customers in 14 countries. The remaining 25 per cent of its production supplies the domestic steel market.⁴⁵

Element 25's Butcherbird manganese deposit, south of Newman in Western Australia, is Australia's largest onshore manganese resource. The deposit has an inferred resource of 180mt at 10.8%. A pre-feasibility study is due for completion in mid-2019. Element 25 intends to produce high-purity manganese sulphate from Butcherbird for use in lithium-ion battery cathodes. The company has recently produced high-purity electrolytic manganese metal in leach test work.

IRON

Iron is a major component of the cathode for LFP and LMFP chemistries. Steel is sometimes used as the container for cylindrical lithium-ion battery cells.

Figures 23 & 24: Iron ore reserves and production by country

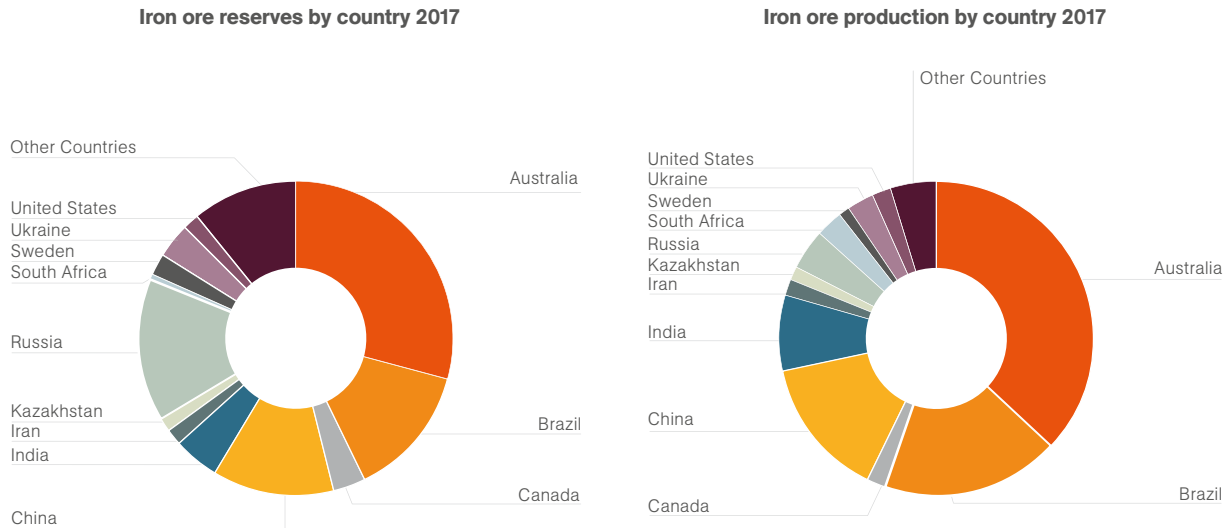

Source: USGS (2018)

Australia's resource base and production

Australia has the world's largest estimated reserves of iron ore with 52 billion tonnes, or 30 per cent of the world's estimated 170 billion tonnes. Australia is followed by Russia, with 25 billion tonnes (13 per cent), Brazil with 23 billion tonnes (12 per cent) and China, with 21 billion tonnes (but of lower grade) of estimated iron ore reserves. Western Australia accounts for about 98 per cent of Australia's EDR. Much of this is found in the state's Hamersley Province, one of the world's major iron ore provinces. It hosts many deposits ranging in type from premium high-grade hematite ores to channel iron deposits.⁴⁶

In 2016, Australia produced 23,532mt of iron ore of which 27 per cent came from 29 mines.⁴⁷ Australia exported 818mt of iron ore 2016-17.⁴⁸ In volume terms, only China produced more ore than the state of Western Australia.

SNAPSHOT OF AUSTRALIA'S IRON ORE PROJECTS

Rio Tinto operates the world's largest integrated portfolio of iron ore assets. Rio Tinto's Pilbara operations include an integrated network of 15 iron ore mines, four port facilities, a 1,700-kilometre rail network and related infrastructure.⁴⁹ BHP Billiton's Western Australia Iron Ore (WAIO) project covers an integrated system of four processing hubs and five mines, connected by more than 1,000 kilometres of rail infrastructure and port facilities in the Pilbara.⁵⁰ Fortescue Metals Group (FMG) owns and operates an integrated supply chain comprising three iron ore mines in the Pilbara and 620km of the world's fastest, heavy-haul railways. Exploration activity in the past year has been primarily focused on iron ore tenements to maintain mine life and sustain product quality.⁵¹

PHOSPHATE

Phosphate is a material component of the LFP chemistry cathode material. It is also a component of the common electrolyte for all lithium-ion battery chemistry – lithium hexafluorophosphate (LiPF₆).

Figures 25 & 26: Global phosphate production and reserves by country

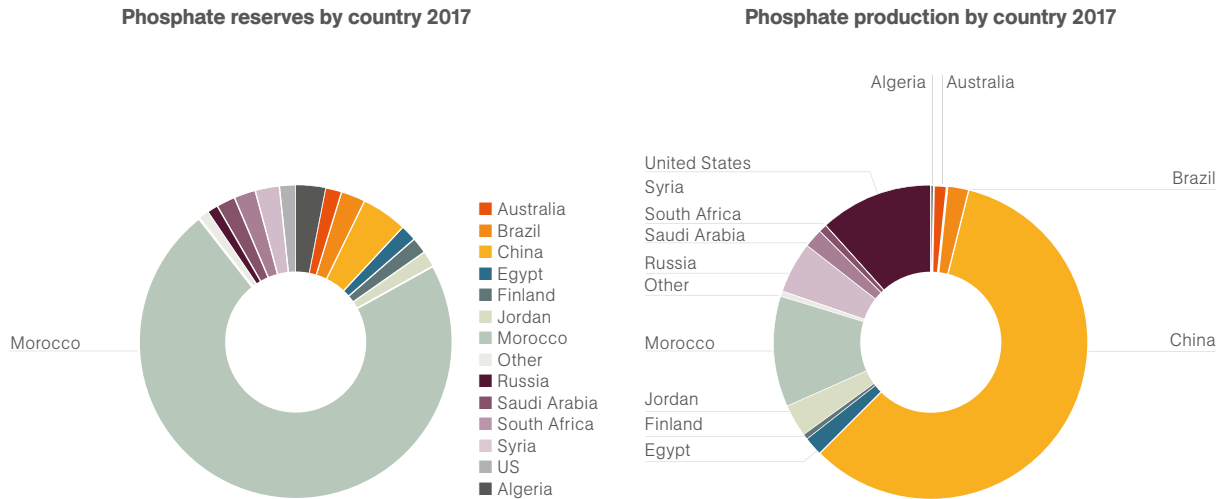

Source: USGS (2018)

Australia’s resource base and production

Australia has around two per cent of the world’s economic resources of phosphate rock (1,072mt in 2016). The phosphorites of the Georgina Basin (Queensland and Northern Territory) account for 90 per cent of Australia’s EDR. The remaining phosphate rock occurs at Christmas Island.⁵² Christmas Island and Phosphate Hill process ore through blending to create a product specific to customer needs which is then dried and crushed.⁵³ Verdant Minerals has environmental approval for its planned Ammaroo phosphate project, 220km south-east of Tennant Creek in the Northern Territory. Verdant hopes to produce an initial 1mtpa of phosphate rock from 2019. Other current and potential phosphate producers include Krucible Metals, Paradise Phosphate, Legend International Holdings, National Mineral Development Corporation, Arafura Resources, Rum Jungle Resources, NuPower Resources, Korab Resources, Lynas Corporation, Kimberley Rare Earths, and Forge Resources.

PHOSPHATE HILL

Incitec Pivot’s Phosphate Hill fertilisers refinery in North West Queensland (approximately 1,000km from Townsville) manufactures ammonium phosphate fertilisers. In addition to its beneficiation, ammonia, phosphoric acid and granulation plants, Phosphate Hill has its own phosphate mine and ore processing facility.

With an annual capacity of 975,000 tonnes, Phosphate Hill combines world-class and low-cost manufacturing plants, its own phosphate rock reserve and ammonia production from gas sourced from long-term gas supply agreements.⁵⁴

TITANIUM

Titanium is a component of the anode in LTO type chemistries. This chemistry has some advantages over graphite anodes in terms of charge/discharge speed and thermal stability. It is often partnered with an NMC or LMO based cathode.

Figures 27 & 28: Titanium production and reserves by country

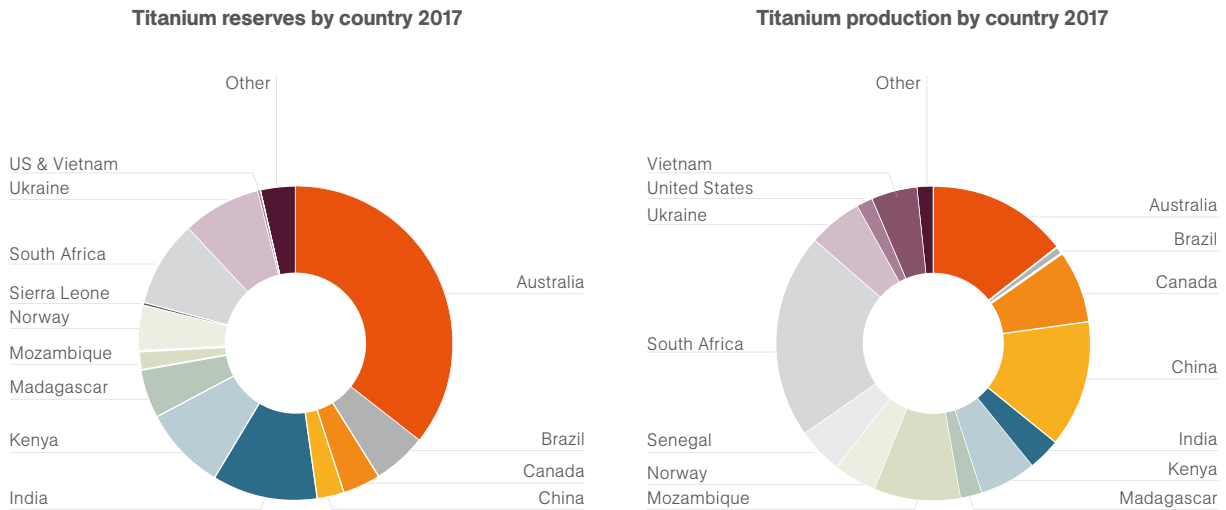

Source: USGS (2018)

Australia's resource base and production

Australia accounts for around 13 per cent of the global titanium production of ilmenite. Other leading ilmenite producers include China (16 per cent) and Vietnam (10 per cent). Australia also produces around 30 per cent of the world's rutile followed by Sierra Leone (23 per cent). Victoria hosts Australia's largest share of known rutile resources (just over 50 per cent) while Western Australia hosts just under 50 per cent of known ilmenite resources. Internationally, Australia hosts around 40 per cent of global rutile resources, compared to Kenya (24 per cent), South Africa (15 per cent) and India (14 per cent) and 19 per cent of global ilmenite resources, compared to China (27 per cent), India (11 per cent) and South Africa (9 per cent).⁵⁵

NEOMETALS

Neometals' Barrambie Project is a globally significant hard-rock titanium-vanadium asset located approximately 800km from Perth. It has a JORC-compliant mineral resource of 280mt grading 9.18 per cent titanium dioxide and 0.44 per cent vanadium pentoxide.⁵⁶ The company is now undertaking a dual track evaluation of development alternatives for its 100 per cent owned Barrambie project.

NATIONAL TITANIUM DIOXIDE COMPANY LTD (CRISTAL)

Cristal's Bunbury operations incorporate two facilities at Kemerton and Australind that produce titanium dioxide (TiO₂) for Cristal's Millennium inorganic chemicals business.⁵⁷

ILUKA RESOURCES

Iluka Resources is the largest producer of titanium dioxide-derived rutile and synthetic rutile globally. Iluka produces from a plant in Western Australia, has mines in Victoria, and a wholly-owned subsidiary in Sierra Leone.

ALUMINIUM

Aluminium has a number of applications in lithium-ion batteries. It is often used as the current collector for cathode, as well as being part of the cathode material in NCA chemistry. Aluminium is also used as a component of the cell enclosure.

Figures 29 & 30: Bauxite reserves and alumina production by country

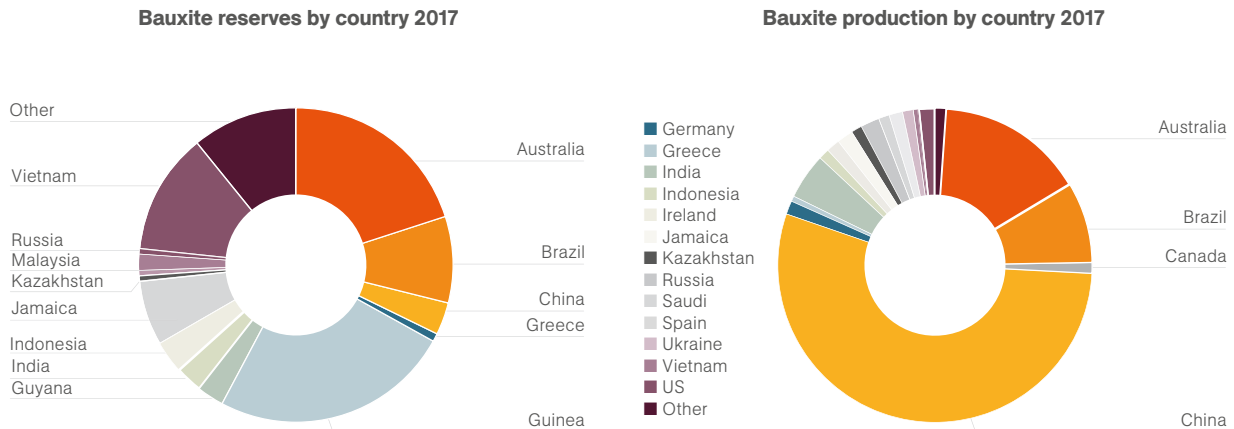

Source: USGS (2018)

Australia’s resource base and production

Australia is ranked first globally for bauxite production and alumina exports and second for alumina production.⁵⁸ Australia’s bauxite production rose by 6.9 per cent year-on-year in the first half of 2017-18, driven by higher output from Rio Tinto’s Gove and Weipa operations⁵⁹ Australia’s aluminium industry continues to be a highly integrated sector of mining, refining, smelting and semi-fabrication and is of major economic importance nationally and globally.⁶⁰

ALCOA

Alcoa operates three Western Australia-based alumina refineries in Kwinana, Pinjarra and Wagerup. Each year Alcoa mines close to 32mt of bauxite, which it refines into nine million tonnes of alumina, which is smelted into 300,000 tonnes of aluminium. Alcoa produces almost 43 per cent of Australia’s alumina and approximately 20 per cent of Australia’s aluminium. Its alumina production accounts for close to 8 per cent of total world demand. Alcoa operates a smelter in Portland with capacity of approximately 358,000tpa of aluminium.

RIO TINTO

Rio Tinto’s alumina operations in Australia include the Yarwun refinery, near Gladstone in Queensland, and an 80 per cent holding in Queensland Alumina (QAL). The Yarwun refinery processes bauxite sourced from the group’s Weipa mine in Cape York. Rio Tinto is expanding its bauxite and alumina operations at the Weipa mine, a \$A2.6 billion project that is projected to be fully operational by 2019.

Rio Tinto has a 59.4 per cent holding in the Boyne Island aluminium smelter. Aluminium output totalled 301kt for the year ending December 2017. Japan is the smelter’s major market, accounting for virtually all export sales, through equity off-takes and long-term contracts. Rio Tinto also has a 51.6 per cent interest in the Tomago smelter in New South Wales. Smelter production totalled 305kt in 2017. The company’s wholly owned Bell Bay smelter in northern Tasmania processes alumina from the Queensland Alumina Refinery and provides 1,500 jobs. In 2017, the smelter’s output was 187kt.

SOUTH32

South32 has an 86 per cent interest in Worsley Alumina's Worsley project, comprising a bauxite mine and the Mount Saddleback refinery. The project is a joint venture with Japan Alumina Associates (10 per cent) and Sojitz Alumina (4 per cent). The Worsley refinery processes ore extracted from the associated Mount Saddleback bauxite mine. The alumina produced at Worsley is distributed between the joint venture participants in accordance with their shares in the project, and it is exported from the port of Bunbury, Western Australia.

Chemicals and related inputs

Australia has a mature chemical manufacturing and distribution sector for both organic and inorganic chemical products. The policies that govern chemical manufacture, storage, transport and use have been established by the Australian Government's statutory body, Safe Work Australia. Regulations safeguarding their use are applied at the federal, state and territory level.



Sulphuric Acid

Sulphuric acid is used to create lithium sulphate. Acid plants in Australia are located alongside smelting facilities and are used to reduce sulphur dioxide stack emissions while obtaining a useful by-product. Sulphuric acid plants in Australia are based in Kalgoorlie, Olympic Dam (BHP Billiton), Ravensthorpe (First Quantum), Alligator Rivers (Energy Resources Australia), Mount Isa (Incitec Pivot), Murrin Murrin (Minara Resources), Hobart and Port Pirie (Nyrstar), Port Kembla (Orica) and Townsville (Sun Metals).

Phosphoric Acid

Phosphoric acid is used in the production of lithium-ion iron phosphate cathode material. Wesfarmers CSBP imports phosphorous and uses sulphuric acid sourced from BHP's project in Kalgoorlie to create phosphoric acid in Kwinana, Western Australia. Incitec Pivot mines mineral phosphorous at their Phosphate Hill project, which is combined with sulphuric acid (sourced from Glencore's Mount Isa Copper Smelter) to produce phosphoric acid.⁶¹

Lime

Lime assists with the separation of lithium, copper, nickel and other non-ferrous elements. Lime, as a strong alkali, is also used to neutralise any acidic solutions developed during separation, concentration and refining.

Cement Australia produces lime in Railton (Tasmania), Gladstone (Tasmania), and Bulwer Island (Queensland). Other lime producing companies include Adelaide Brighton Cement, Boral Cement, Cockburn Cement and Swan Portland Cement. Separator material is typically polyethylene or polypropylene. Polyethylene is produced by Qenos in Melbourne and Sydney and polypropylene is manufactured by LyondellBasell in Geelong.

Soda Ash (soda carbonate)

Soda ash is used to precipitate lithium carbonate from process solution. This material is similar to the carbonate produced from brine lakes. Australia does not produce soda ash – it is imported in bulk to support multiple industry uses, including water treatment, mining operations, fertilizer manufacture, and detergents.



The VSPC Brisbane plant. Image courtesy of Lithium Australia.

THE CASE FOR LITHIUM-ION BATTERY PRODUCTION IN AUSTRALIA

Rising demand for lithium-ion batteries for energy storage offers economies of scale to all new potential downstream market entrants.

Australia holds significant global supply-chain advantages by having almost all of the necessary mineral elements and chemicals, combined with world-leading and demonstrated expertise in resource extraction and processing, high-tech engineering, and renewables research. Moreover, Australia's accessible resource base enables a short supply-chain production capacity that can both continue to supply raw materials, while enabling efficient domestic refining, processing and manufacturing of finished products for global markets.

A missed opportunity?

Australia's value proposition rests on the ability to source, refine and produce all key materials in the lithium-ion battery supply chain under one open market jurisdiction. Future Smart Strategies claim Australia currently earns only 0.53 per cent of ultimate value of its exported ore (A\$1.13 billion) — see Figure 31. Some 99.5 per cent (of an estimated A\$213 billion) of the value of Australian lithium ore is added through offshore electro-chemical processing, battery cell production and product assembly. For example, about 2.5 tonnes of ore is needed to produce approximately 650 kilograms of concentrate.

Figure 31: Lithium Value Chain 2017-2025

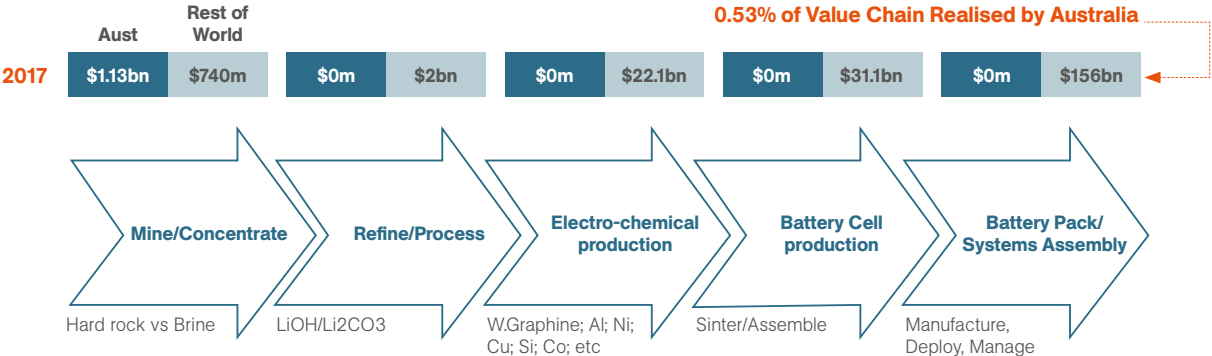

Source: Future Smart Strategies (2018)

This then must be refined to 100 kilograms of lithium hydroxide to supply 18 kilograms of lithium metal needed to produce the batteries for an average electric vehicle.⁶² Frost & Sullivan estimate the total projected revenue for lithium-ion battery materials at US\$14,556 billion with a CAGR of 11.5 per cent from 2016 to 2023.⁶³

Australia’s secure access to lithium-ion battery inputs

As noted above, Australia has unparalleled access to the essential mineral element inputs to support the lithium-ion battery supply chain (see Figures 32 and 33). Australia has domestic supplies of every mineral required to produce all LFP, NMC and NCA lithium-ion battery anodes and cathodes, as well as access to the necessary chemicals.

Figure 32: Australian reserves of the major mineral inputs required for lithium-ion battery production

Mineral	Mt
Lithium	2.7
Cobalt	1.2
Nickel	18.5
Iron	49,588
Copper	87.8
Manganese	219
Alumina (Bauxite)	6,005
Graphite	1.1
Titanium (Ilmenite, Rutile)	310
Phosphate	1,072

Source: GeoScience Australia

Figure 33: Mineral resource reserves relevant to manufacturing lithium-ion batteries

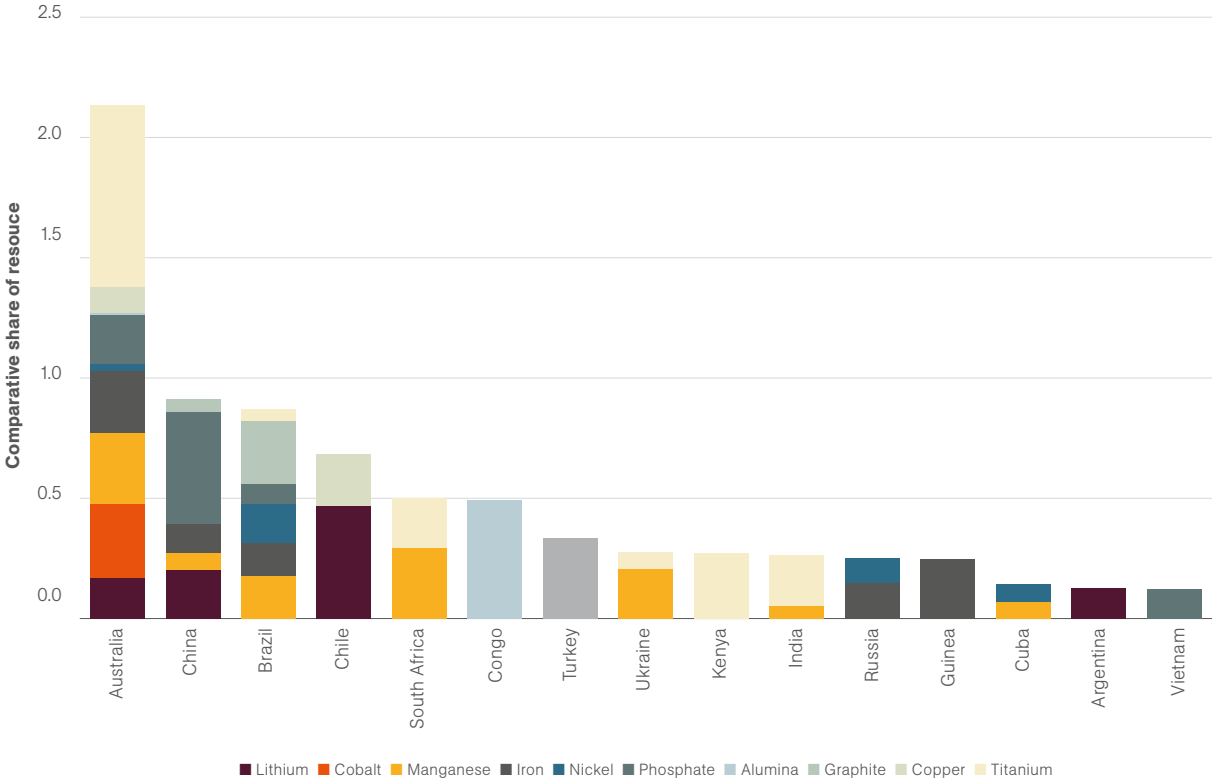

Source: USGS (2018)

Figure 34: Countries with reserves or relevant cathode material

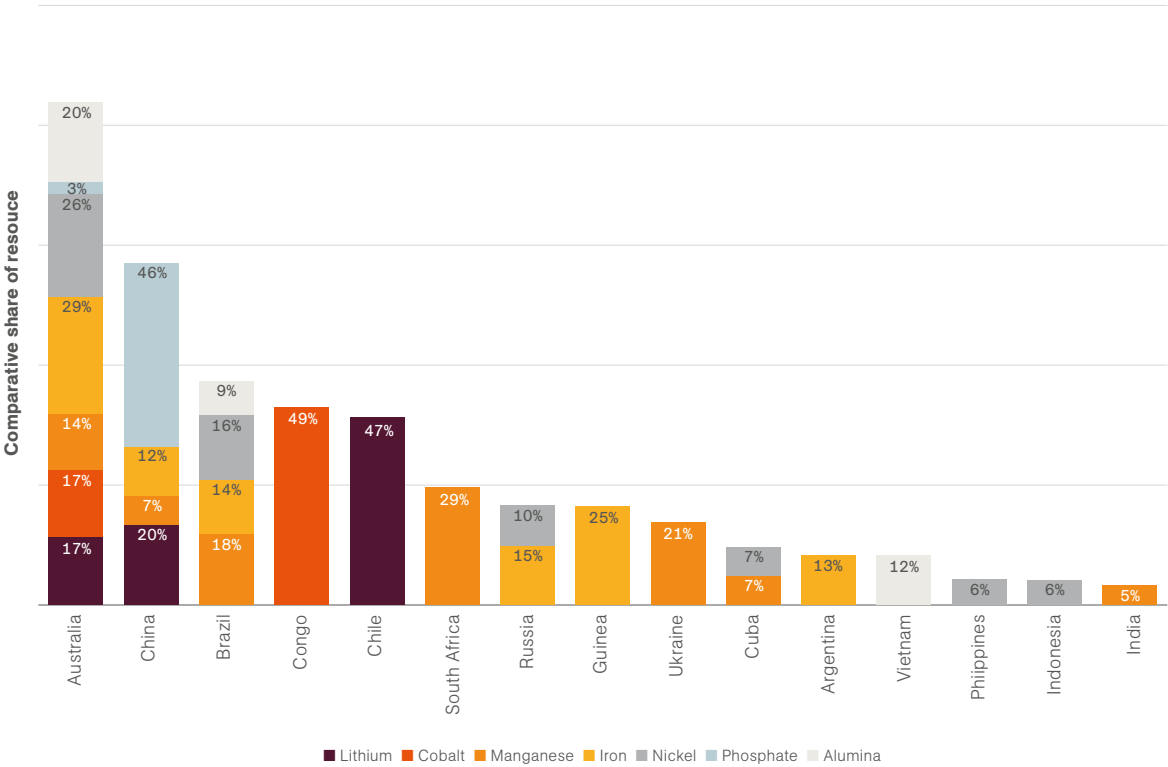

Source: USGS (2018)

Australian movement into the lithium-ion batteries value chain

To date, there has been no commercial-scale lithium-ion battery manufacturing in Australia. However local lithium producers are beginning to move into new areas of the lithium supply chain. On top of the steps being taken by Albemarle, Tianqi, and Covalent Lithium, Energy Renaissance is planning to build a 1GWh manufacturing facility in the Northern Territory to produce low cost lithium-ion batteries optimised for warm climates. The Queensland State Government has committed A\$3.1 million towards a feasibility study for a 15GWh Gigafactory in Townsville.⁶⁴ This project is being developed by an international consortium called Imperium3 led by Boston Energy and Innovation, ASX-listed graphite company Magnis Resources and Charge CCCV LLC. The consortium has begun testing manufacturing processes and production of prototype battery products. The facility will produce either car batteries, home storage battery units or micro grids to power small towns. First production is expected by 2020.

Lithium Australia is seeking to supply ethically and sustainably sourced materials to the battery industry on a global scale. On top of holding lithium positions across various continents, Lithium Australia has developed energy-efficient, proprietary technologies to extract lithium and other energy metals from unconventional sources (including mine waste and spent batteries) and transform them into chemical precursors for lithium-ion batteries. Its principal business activities units are: acquisition of raw materials – exploration and alliances in Australia, Europe and North America; primary lithium extraction – SiLeach[®] hydrometallurgical processing (no roasting); production of superior battery cathode materials – VSPC Ltd proprietary nanotechnology; and recovery of energy metals from of spent batteries and e/waste – RCARC Pty Ltd (see section on page 38 on recycling).

Lithium Australia is evaluating the business case for manufacturing lithium-ion battery precursors, most of which are currently produced in China. To that end, Lithium Australia recently completed second generation pilot testing of its SiLeach[®] process at ANSTO Minerals, which successfully recovered lithium chemicals from mine waste. SiLeach[®] can produce lithium carbonate, hydroxide or phosphate, as well as a range of by-products that include silicon and aluminium chemicals.

The lithium chemicals produced using SiLeach® went to VSPC, Lithium Australia's wholly owned lithium-cathode pilot plant and battery-testing facility in Queensland. There they were used to produce complex, high-grade lithium cathode powders, as well as (on a lab scale) batteries for evaluation in VSPC's battery testing facility. Lithium Australia currently has cathode powders available for specification testing by international energy customers.

The Future Battery Industries Cooperative Research Centre (FBICRC) is seeking to support Australian development of mineral processing, battery manufacturing, deployment, reuse and recycling. The FBICRC hopes to do this by enabling Australian industry, governments and researchers to optimise the cost competitiveness and productivity of Australian energy storage metals, materials and systems to meet market growth. It will enable value creation, sustainability and global competitiveness through the battery value chain.

The FBICRC is requesting \$A25 million in funding from the CRC programme over a five-year period, commencing on 1 July 2019. The 42 partners in the FBICRC are committing \$A26.18 million in cash and

\$A13.15 million of in-kind contributions. The estimated impact of the partner investment matched with \$A25 million Commonwealth investment is forecast to be A\$1.23 billion over a 15-year period. Three research programs, with multiple research activities, will address the requirements of industry including: battery industry development; battery resources, processing and recycling; and battery materials, components, manufacturing, testing and deployment.

Cost competitiveness

Australia has some expected cost advantages over other lithium-ion battery producers (see Figure 35). Australia also has a comparative advantage over South American companies producing from lithium brine. McKinsey and Roskill figures suggest it is at least 10 per cent cheaper to convert spodumene to lithium hydroxide than South American brine. Growing demands for more robust environmental compliance in China will help reduce the release of dangerous chemicals and resulting damage, but could erode at least some of its cost competitiveness.



Figure 35: Cost variables for countries manufacturing lithium-ion battery cells

	Factory Construction cost USD/m²	Skilled Technical labor USD/hr	Industrial electricity US c/kWh
China	333	5	14
Chile	554	9	8.05
South Korea	950	22	25
Poland	420	6	10.46
USA	656	85	10.0
Australia	578	60	9.71

Sources: Turner and Townsend; OECD; National Renewable Energy Laboratory; CEIC; Korean Times. It should be noted that the above table does not take account of effective productivity.

Scale and expertise of the Australian mining sector

Mining is a significant driver in the Australian economy. In 2016-17, Australia's resources and energy exports, including minerals, metals and petroleum, posted a new record high value of A\$204 billion, accounting for 53 per cent of Australia's total goods and services export revenue.⁶⁵ Australia's resources and energy export earnings are forecast to reach A\$226 billion in 2017-18 – the highest on record.⁶⁶ In 2017, mining and METS accounted for 15 per cent of Australia's GDP.⁶⁷ Mining contributes 1.1 million jobs nationwide, around 10 per cent of overall employment.⁶⁸

Australia has a long history of rapidly scaling-up resource production through its ability to innovate, develop and apply new technology. These dynamics continue to be reinforced by the extensive engagement of Australian management in global mining projects. Australia's share of global lithium production over the past two years highlights Australia's capability to scale up in response to global demand. As demand for key materials including lithium, nickel and cobalt have increased, Australian resource companies have demonstrated an ability to expand supply faster than any competitor. The reasons for this are many but include: hard rock mining expertise and efficiency; effective and efficient logistics; excellent natural resources; innovation; and research and development.

Infrastructure

Australia's high-quality roads, ports and rail networks offer considerable comparative advantages to supply chains in the lithium-ion battery market. All of Australia's major shipping ports and industrial centres are connected by established road and rail infrastructure. Australia was ranked 18th out of 160 countries in the World Bank's 2018 Logistics Performance Index,⁶⁹ ahead of all other countries supplying key materials for lithium-ion battery manufacturing.

Australia has single ocean access to more than 50 per cent of the world's population, with the fastest growing global economies accessible from the continent's west and north coasts. Australia is well positioned to provide finished products to support economic development and the expectations of the growing middle-class in the fast-growing Asian region. Access to European and North American markets also positions Australia as an alternative and reliable source of energy materials to meet increasing demand in established markets.

Workforce and skills

Australia has a highly-educated workforce that can drive innovation and grow international businesses in the lithium-ion battery sector. Australia is rated by the World

Economic Forum as the ninth-most competitive country in the world in terms of its education and training.⁷⁰ More than 40 per cent of Australian workers on average hold a tertiary qualification. Australia has six universities in the world's top 100;⁷¹ a number only exceeded by the United States and United Kingdom. Over recent years, Australia has produced more than seven per cent of the world's most highly cited research publications despite having less than half of one per cent of the world's population.⁷²

Australia has one of the safest, cleanest and most productive mining sectors in the world. Productivity levels for the Australian mining sector are more than 40 per cent above the global average.⁷³ Australia's minerals industry workforce is abundant, young, diverse and well educated. More than 42 per cent of the mining workforce is aged between 25 to 39 years.⁷⁴

Support for innovation and high-tech industries

Australia is an excellent partner for industries in the lithium-ion battery sector on account of its world-class scientific and research institutions, access to modern research infrastructure and strong intellectual property protections. In August 2018, the Economist Intelligence Unit ranked Australia as one of the three most future-ready countries in its annual Technological Readiness Ranking of 82 countries.⁷⁵ Australia was also rated as one of the most attractive high-tech business investment environments on account of its openness to innovation, international patents, research and development spending and research infrastructure.

The Commonwealth Scientific and Industrial Research Organisation (CSIRO) is ranked in the top one per cent of the world's scientific institutions in 14 research fields.⁷⁶ Australia's knowledge and technology-intensive industries add more value to its economy than the equivalent industries in France, Canada, Italy and South



Korea. The quality of Australia's infrastructure, human capital and research, and scientific research institutions are ranked in the world's top 10.⁷⁷

Innovation and science are major contributors to Australia's economic, cultural and social advancement. In 2017–18, Australia had plans to invest A\$21 billion in gross expenditure on research and development (GERD) on current PPP dollar terms. Australia's GERD commitment places it among the world's leading innovative countries, including the US, Japan, Germany and South Korea.

Australia's GERD has risen on average by 73 per cent each year since 2000, well above the OECD average growth rate of 5.1 per cent.⁷⁸ Australia is ranked fifth in the world for global entrepreneurship.⁷⁹ Nearly half of Australian businesses are considered to be innovation active, across a broad range of industries.⁸⁰

Leading safety and environmental practices and safeguards

Australia sets transparent and high-quality standards for all resource sector participants. Australian investors, customers and suppliers can be confident that ethical and sustainable operations are enforced by considered regulation. Federal, state and local governments jointly administer environmental laws. The Department of Environment and Energy administers the Environment Protection and Biodiversity Conservation (EPBC) Act, which covers the assessment and approval process of relevant national environmental issues. The Department also administers specific Acts that cover activities relating to the sea, importing, heritage issues, hazardous waste and fuel quality.

Figure 36: Forecast growth of global battery storage

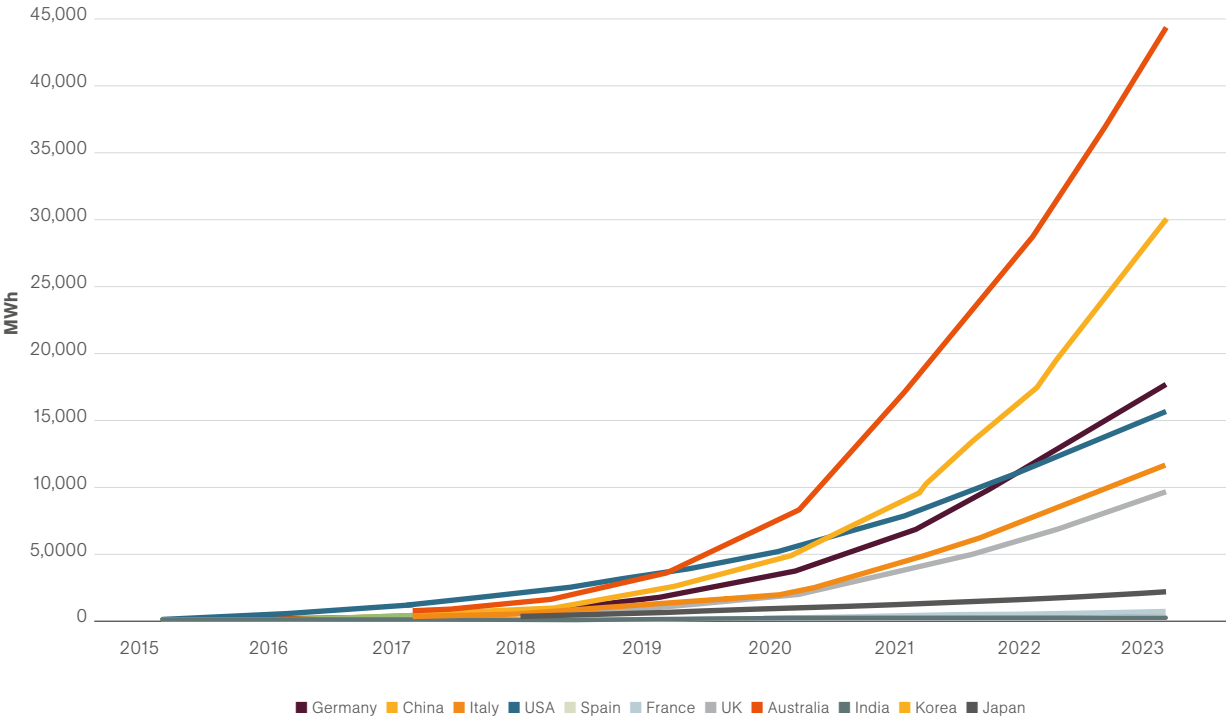

Source: Future Smart Strategies (2018)

Local drivers

Australia has demonstrated a rapid take-up of new energy solutions, evidenced by our position as the world's per capita leader in rooftop solar photovoltaic systems, our hosting of the world's largest lithium-ion utility scale battery, and our position as a destination for battery energy investment. A close focus on

dispatchable energy, especially for the National Electricity Market (NEM), features among one of the Commonwealth Government's major energy commitments. Moreover, Australia has an EV charging network despite low EV penetration. Domestic demand is forecast to exceed 30GWh per year by 2025⁸¹ – four times the annual capacity of the integrated plant being constructed in Hungary by SK Innovation.



Opportunity for lithium-ion battery recycling

Efforts are underway globally to recycle material from end-of-life lithium-ion batteries, driven by the high relative content and price of cobalt (see Figure 37). These measures focus on older LCO cathode chemistries which have a higher cobalt content. However, the supply stream for these lithium-ion batteries is still small, making it difficult to achieve economic returns from small scale operations. There is currently no cost-effective method to process the newer battery cathode chemistries (LMO, LFP, NCA, and NCM).

Only two per cent of Australia's annual 3,300 tonnes of lithium-ion battery waste is currently recycled, with the remainder shipped overseas. The CSIRO claims Australia could lead the world in the re-use and recycling of lithium-ion batteries.⁸² The agency suggests a recycling industry could not only address waste

issues but stabilise global lithium supplies to meet consumer demand. If recycled, 95 per cent of waste components could be turned into new batteries or used in other industries.

A significant opportunity exists to innovate in this sector in order to deliver greater environmental and economic returns in the medium-long term. Australia has the capability to contribute to recycling technology improvements by applying much of the technology developed for the mining sector. Lithium Australia, through its subsidiary RCARC, is joining the global effort to recycle material from end-of-life lithium-ion batteries (and e-waste), much of which is still consigned to landfill, despite the relatively high cobalt content of a range of battery chemistries. Lithium Australia's move into recycling is driven by environmental concerns, as well as current constraints on cobalt supply and lithium sustainability. To address these issues, the company is developing new processing technologies and actively exploring supply opportunities.

Figure 37: Battery recycling flow diagram

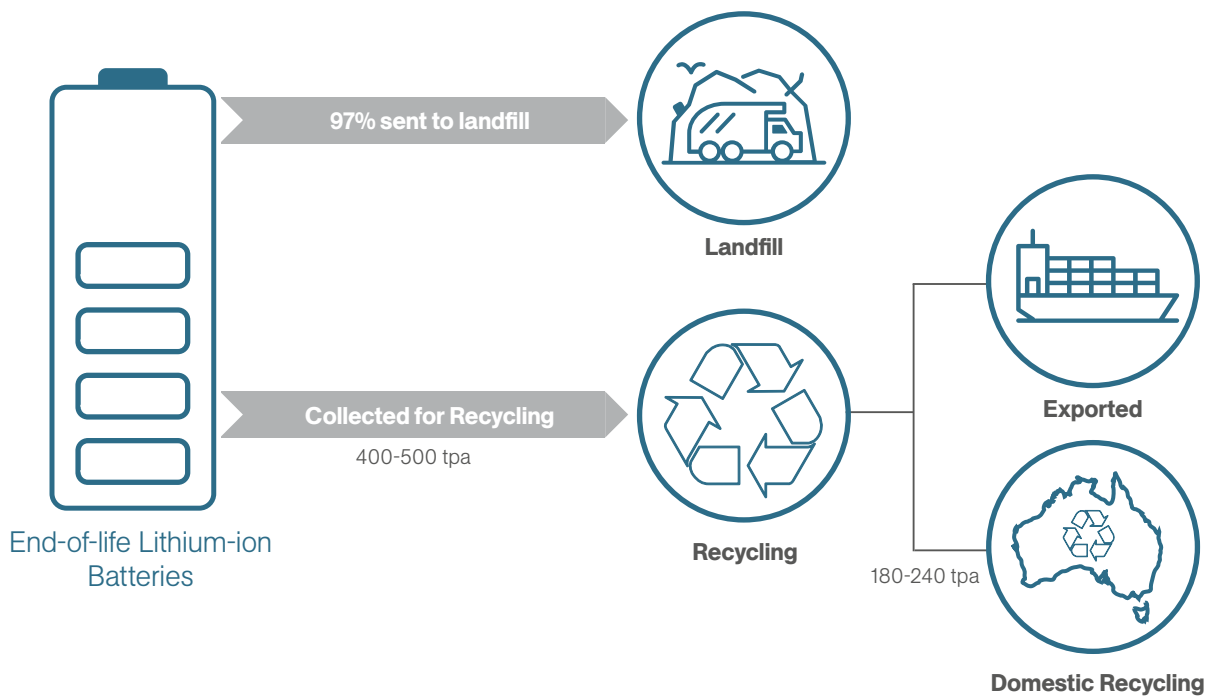

Source: Source: Future Smart Strategies (2018)



WHY AUSTRALIA?

In addition to access to raw materials, infrastructure and expertise in resource extraction and processing, Australia is also a safe and secure place to invest and do business.

Australia's democratic institutions, governance, and transparent regulatory system set it apart from the majority of its competitors, underpinning its economic resilience and minimising sovereign risk. Australia's efficient business frameworks also make it relatively easy for multinationals to set up their operations. Australia offers:

- › a strong economy and business environment ranked 18th out of 190 economies for ease of doing business. Australia is ranked fifth in the world for economic freedom
- › a sophisticated economy suited to high-tech industries supported by leading scientific and education institutions and a highly educated workforce
- › a robust regulatory system noted for its institutional frameworks and finance and banking regulations

- › a stable political system, strong legal institutions and sophisticated anti-corruption regimes.

A robust economy

Growing by more than three per cent on average each year since 1992, Australia is now in its 28th year of consecutive growth.⁸³ The Australian economy's resilience is sustained by robust policy frameworks, strong and resilient institutions, sophisticated financial systems, an attractive investment environment and deep economic ties with the Asian region. Australia is a top 20 global economy and member of the G20, the world's premier forum for international economic cooperation. Australia is the only major developed economy not to have recorded an annual recession from 1992 to 2017.

The Australian economy is:

- › the 14th largest in the world
- › rated AAA by all three global rating agencies



- › forecast to realise average annual real GDP growth of 2.7 per cent over the period 2019 to 2023 – the highest among major advanced economies⁸⁴
- › diversified, with the services sector accounting for three-quarters of real gross domestic product.

International competitiveness

The World Economic Forum⁸⁵ ranks Australia 14th out of 140 countries in its Global Competitiveness Report 2018, which tracks performance on 12 pillars of competitiveness. Australia's rating is attributed to its strength in education and factors contributing to a stable investment environment. This index places Australia as the most competitive of all countries with a significant interest in the lithium-ion battery market, above South Korea (15), Poland (37) Hungary (48) and China (28). Australia is also the most competitive of all the major resource suppliers including Chile (33), Argentina (81), Zambia (118) and Democratic Republic of Congo (135).

Global ties

Australia's portfolio of Free Trade Agreements grants preferential access to some of the world's largest markets in Asia. Trade agreements also facilitate the smooth exchange of goods, services and investment with major economies across Asia, Europe and North America.

Australia is ranked fifth of 180 of the most economically liberal nations in the 2018 Index of Economic Freedom produced by the US-based Heritage Foundation.⁸⁶ Australia's robust free-market democracy, effective system of government and entrepreneurial development all contributed to this status.

Australia has an open trading economy

- › Ten of the country's top 12 export markets are within the Asian and Oceania region
- › Two-way trade in goods and services totalled A\$763 billion in 2017
- › Inward foreign investment stock totalled more than A\$3.3 billion by the end of 2017⁸⁷
- › Inward foreign direct investment stock reached A\$849 billion in 2017



Investment attractiveness

The Government has prioritised attracting foreign investment as a key pillar of Australia's economic and commercial diplomacy. Australia's world record uninterrupted economic growth over the last 27 years would not have been possible without new FDI, which totalled more than \$645 billion over the past five years. FDI underpins economic growth, creates jobs, improves productivity, and enables the transfer of new technologies.

Australia's open, well-regulated and stable economy, underpinned by strong institutions and a talented, highly skilled workforce, contributes to Australia's position as an attractive investment destination. In 2017, the total value of FDI came to almost \$A900 billion; in 2007, that figure was \$400 billion and in 1997, the figure was \$150 billion.⁸⁸ The overall compound annual growth rate from 1997 to 2017 was 8.6 per cent.⁸⁹ While foreign-owned firms make up 0.5 per cent of Australia's operating businesses, they produce nearly 30 per cent of exports and contribute around one-fifth of Australia's economic output.

The Australia Benchmark Report provides rich data demonstrating why there is no better place than Australia to do business. The report examines five key reasons for investing in Australia and compares Australia's credentials with other countries. The Milken Institute's 2017 Global Opportunity⁹⁰ ranked Australia as the fourth-most attractive investment destination – the highest of any resource-rich nation. This ranking was based on:

- › economic fundamentals
- › financial services
- › business perceptions
- › institutional frameworks
- › international standards and policy



GAP ANALYSIS

What does Australia need?

Australia requires the proprietary equipment, processes and technology to convert its raw materials into end-user lithium-ion batteries. Australia does not yet have the domestic capability to refine and manufacture coated spherical graphite from flaked graphite; polymer separator; and cell enclosure material; and copper and aluminium foils for electrodes and electrolyte. While there will be technological upgrades to the current chemistry and architecture of lithium-ion battery cells over the next decade, many chemistries will remain consistent. While new technologies are being developed,⁹¹ it is reasonable to expect that the 10 core mineral elements identified in this report will continue to comprise the key components of every lithium-ion battery chemistry in commercial production.

Targeting FDI and technology transfer

As noted, despite some progress by Australian companies in developing relevant technologies and even small-scale lithium-ion battery capabilities, Australia needs to attract investment and technology transfer and/or patents from existing lithium-ion battery manufacturers to develop the required level of capability. Following is a profile of the lead manufacturers:

BYD CO LTD – CHINA – MARKET CAP \$21.54 BILLION

Founded in 1995, BYD Co Ltd (“Build Your Dream”) began as a rechargeable-battery factory competing in the Chinese market against Japanese imports.⁹² BYD grew quickly capturing more than half the world’s mobile phone battery market within 10 years. BYD currently has three core businesses: information technology; automotives (including EVs); and lithium-ion battery storage systems. BYD is ranked number one globally in sales volumes of new energy vehicles (both EVs and hybrids). Headquartered in Shenzhen, BYD manufactures across nine hubs in China, as well as subsidiaries in India, Japan, Korea, North America, Europe, and Australia. BYD, with 16-17 per cent of the lithium-ion battery market,⁹³ is a leading producer of rechargeable batteries: NiMH batteries, lithium-ion batteries and NCM batteries. BYD owns the complete supply chain from mineral battery cells to battery packs. BYD will open a 24GWh power battery factory in Western China’s Qinghai province in 2019. The high-tech factory, which is equivalent to the size of 140 football fields, will be the largest in the world, and BYD’s third battery factory in China after Shenzhen and Huizhou.⁹⁴ BYD shareholders include: Berkshire Hathaway, Inc. (24.5 per cent); Himalaya Capital Management LLC (8.2 per cent) and The Vanguard Group, Inc. (2.5 per cent).

LG CHEM – KOREA. MARKET CAP: US\$24.61 BILLION

LG Chem is the chemical arm of LG Group and estimated to have 16-17 per cent market share of the lithium ion battery sector – on par with BYD.⁹⁵ It was founded in 1947 and is the largest Korean chemical company.⁹⁶ LG Chem manufactures batteries for a variety of purposes, including laptops, power tools, smartphones, e-bikes, garden tools, power banks and digital cameras.

Since 1999 LG Chem's lithium battery sales have averaged over 30 per cent year on year growth. LG Chem and Panasonic are the leading battery suppliers for the North American market. LG Chem's battery technology is the most used in the EV markets, with key users including Daimler and Great Wall. LG Chem has 16 overseas manufacturing plants, including in China, Taipei, Poland and the United States.

CONTEMPORARY AMPEREX TECHNOLOGY (CATL) – CHINA. MARKET CAP: US\$26.45 BILLION

CATL specializes in the manufacturing of lithium-ion batteries for EVs and energy storage systems, as well as battery management systems (BMS). It is headquartered in Ningde, Fujian Province and operates manufacturing bases in Ningde, Qinghai and Liyang. Its three main R&D centres are based in Ningde, Shanghai and Berlin. CATL makes both LFP and NMC batteries for the electric bus market. An IPO in Jun 2018 raised Rmb5.46bn (A\$853m), which will be used to establish new manufacturing plants in China and Germany.

CATL is estimated to have 8 per cent of the Lithium-ion battery market. CATL's customers include a number of Chinese automobile companies such as Yutong, the world's largest electric bus manufacturer. CATL also has supply agreements with BMW, Honda, Hyundai, Nissan, Toyota Nissan and Volkswagen. CATL's battery shipments roughly doubled in 2017 to 12 gigawatt-hours. CATL plans to reach production capacity of 50GWh a year by 2020, enough to power nearly 2 million EVs.

SAMSUNG SDI – REPUBLIC OF KOREA. MARKET CAP: US\$13.65 BILLION

Samsung SDI is a subsidiary of the Samsung Group.⁹⁷ The company's product portfolio includes batteries, solar energy panels, EV batteries, energy storage systems and plasma display panels. It has subsidiaries in America, Germany, Europe, and Malaysia and overseas production facilities in China, Malaysia, Hungary, Austria, Vietnam and the US. Major shareholders include: Samsung Electronics Co., Ltd. (19.5 per cent); National Pension Service of Korea (11.2 per cent)

PANASONIC – JAPAN. MARKET CAP: US\$24.87 BILLION

Panasonic manufactures and distributes electronic and electrical products.⁹⁸ It has a strong presence in North America, Latin America, China, and Oceania. Panasonic is the main EV battery supplier for Tesla. The firm commands 29 per cent of the market for batteries used in plug-in hybrids and EVs. Panasonic started mass production of EV battery cells at Tesla's 'Gigafactory' in Nevada, USA in 2017. The company plans to build a new plant in Dalian China and increase production in Japan. Major shareholders include Panasonic Corp. (4.9 per cent) and Nippon Life Insurance Co. (2.8 per cent).

TOSHIBA CORP – JAPAN. MARKET CAP: US\$20.65 BILLION

Toshiba produces lithium-ion batteries for EVs, industrial and infrastructure applications.⁹⁹ In 2017, Toshiba developed a titanium niobium oxide anode material that has double the lithium storage capacity by volume of the graphite-based anodes generally used in lithium-ion batteries.

The battery offers high-energy density and rapid recharging qualities. Japan's New Energy and Industrial Technology Development Organization (NEDO) funded part of the research work on the next-generation SCiB.

In April 2017, Toshiba, Suzuki and Denso established a joint venture for production of automotive lithium-ion battery packs in India.¹⁰⁰ Shareholders include Effissimo Capital Management (11.3 per cent), Farallon Capital Management (5.3 per cent) and King Street Capital Management (5.2 per cent).

Summary case studies

- › **Tesla/Panasonic integrated 'Gigafactory' in Reno, Nevada.** Investment in 2014 secured by incentives (estimated at US\$1.3 billion) including multi-year exemptions on various taxes, transferable tax credits up to US\$195 million, discounts on power and infrastructure support.
- › **LG Chem Integrated factory in Holland, Michigan.** Investment in 2011 secured by a dollar for dollar federal investment grant (US\$151 million in the first instance), US\$100 million in state tax credits, US\$25 million job creation credits and land supply.
- › **LG Chem integrated lithium-ion battery production facility in Poland.** A 2016 investment in a US\$700 million factory secured by dollar-for-dollar government funding of US\$350 million (as allowed under EU regulations), tax exemptions, employer incentives and land.
- › **Samsung/POSCO cathode facility in Chile** – 2018 investment in a US\$54 million cathode material manufacturing facility secured by assuring guaranteed access to lithium production.

Figure 38: Location of Australia's relevant lithium-ion battery resources

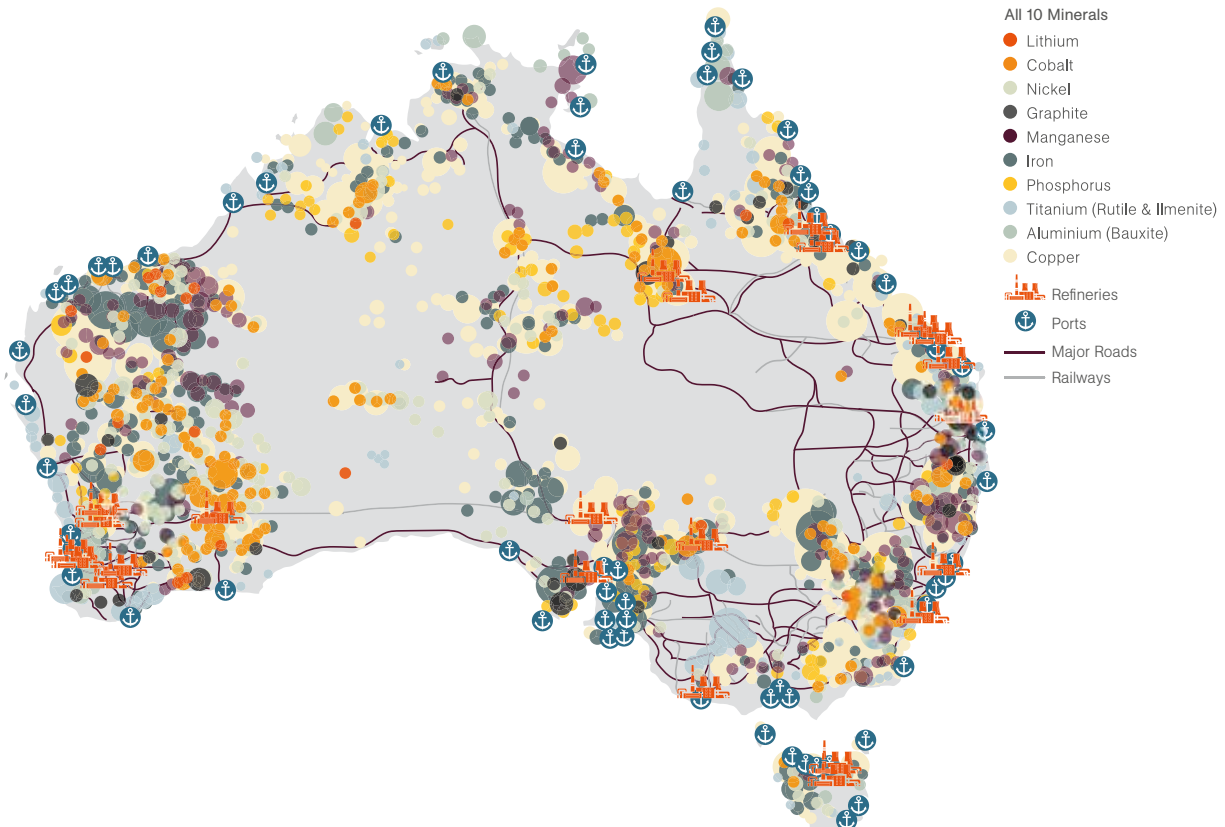

Possible target sites for lithium-ion battery cell manufacturing

Australia has the resources, logistics and capability to produce lithium-ion batteries at many locations, with major drivers being: land availability; proximity to ports and related export infrastructure; labour; energy; and water. Earlier comparisons indicate that none of these are commercial barriers in Australia.

Western Australia

Kwinana, some 38km south of Perth, was identified as an ideal location for lithium-ion battery manufacturing in a recent Regional Development Australia report (RDA Australia 2018),¹⁰¹ on account of its proximity to energy minerals and trade access to the Indian Ocean rim and Europe. Kwinana is an established industrial centre which services world-scale oil and gas, resources and agricultural sectors. Kwinana already hosts refining, fabrication, chemical, research and innovation services and supporting companies. The chemical precursors and other requirements for electro-chemical processing

are already in place. Kwinana represents one of the best global examples of industrial ecology with 158 companies collaborating on industrial waste exchange between industries.

Kalgoorlie is a long-established mining centre positioned close to energy minerals and located 595km east of Perth – approximately the same distance as the Tesla Gigafactory in Nevada is from the Tesla vehicle factory in San Francisco. Land, power and water are all readily available for industrial use. Kalgoorlie is on a national highway and railway freight route with good access to Western Australian ports and domestic airline routes. Nickel and cobalt are refined locally.

Bunbury is 170km south of Perth. Bunbury Port is well connected by rail and road and located two hours from Fremantle and one and a half hours from Kwinana. It is 21km from Kemerton Industrial Park, the proposed site of Albemarle's lithium processing plant.

Figure 39: Possible locations in Australia



South Australia

Adelaide is on national and international freight routes, with an established industrial and manufacturing base, and an operating iron refinery. The South Australian government has offered significant incentives for lithium-ion sector investment. German company Sonnen will establish an energy storage assembly plant in Adelaide using imported lithium-ion batteries.¹⁰² The company plans to produce 50,000 energy storage systems over the next five years for domestic use and export.

In March 2018, The Australian Renewable Energy Agency (ARENA) announced A\$7.7 million in funding for Simply Energy to build a second virtual power plant across Adelaide. The A\$23 million project will deliver Tesla Powerwall 2 home batteries to up to 1200 Adelaide households representing 6MW of residential energy storage. A further 2MW of demand response capacity will be deployed across 10 commercial businesses. The virtual power plant is expected to be up and running by the end of 2019.¹⁰³

Other potential locations for production sites in South Australia include Port Adelaide, the former Holden manufacturing plant, and the closed Mitsubishi plant at Tonsley. In Feb 2018, smelting group Nyrstar has opened its upgraded metals processing plant at Port Pirie, north of Adelaide, a A\$600 million investment.

Queensland

Townsville is the largest city in North Australia and a gateway to mining and agricultural regions. Townsville is positioned near mining regions and has well-established mining logistics systems. As noted earlier, there are already plans for a 15GWh Gigafactory in Townsville.

New South Wales

Newcastle is a major trade and logistics hub. It is the largest port on the east coast and a significant export centre for coal. The CSIRO has established a Stored Energy Integration Facility at the CSIRO Energy Centre in Newcastle.

Victoria

Geelong is located 75km from Melbourne and is a significant port city and industrial centre with extensive chemical and manufacturing capabilities. Primary industries in the region include chemicals and refining, engineering metals and manufacturing. The region has well-established transport and freight infrastructure covering road, rail and Avalon Airport. The Port of Geelong is Victoria's largest bulk commodity port.

The Geelong region is well known as a 'City of Makers and Innovators' with a strong manufacturing heritage.

More than 10,500 people are employed in manufacturing and the region is undergoing a transition from traditional to high-value advanced manufacturing. Innovation has been supported by Deakin University, which has capabilities in robotics, haptics, intelligent systems, data analytics, artificial intelligence and cyber security. The world's leading carbon fibre research facility, Carbon Nexus, is located at Deakin University's Geelong Campus. This project is a partnership between Deakin University and CSIRO and enables Australia to carry out research across the carbon fibre value chain. Geelong is a centre for a 'carbon cluster' of businesses producing a range of automotive, defence, sporting and leisure-related parts and products.¹⁰⁴

Incentivising investment: Commonwealth Government policy support

The Australian Government plays an important policy role in supporting economies of scale for industries of emerging global significance. In doing so, the Government endeavours to put in place the most appropriate industry, infrastructure, regulatory and policy settings to leverage Australia's competitive advantages. Major focal points include supportive infrastructure investment, and funding programmes to develop globally competitive industries. Added to this, the Australian Government supports innovation by investing in enablers such as education, science and research, and infrastructure, incentivising business investment, and removing regulatory obstacles. State and territory governments have their own policies and programs in place to support industries that have competitive advantages.

The Resources 2030 Taskforce report, released in September 2018, makes a range of recommendations on ways to bolster the competitiveness of the resources sector and promote investment. Key focal points of the report included: a stronger base to guide and drive innovation; stronger communities and stronger regions; a high-quality resources base for future generations; and improvements to the mining sector's environmental performance. The report supports continuous improvement across all levels of government service to the resources sector, and welcomes input to ensure the best trade and investment outcomes are achieved by the industry.

To this end, the Australian Government invested A\$9.7 billion in research and development in 2015-16. Around A\$3.2 billion directly supported industry-led initiatives while other funds supported research in universities and agencies such as the CSIRO. The Australian Government also enables innovation by investing in traditional infrastructure such as research laboratories, roads and rail and digital infrastructure such as the NBN and Data61.

Austrade

Austrade contributes to Australia's economic prosperity through investment facilitation, Australian capability promotion, and influencing policies to improve regulatory settings for business. In 2017-18, Austrade contributed to almost \$4.8 billion in recorded investment value from 113 investment outcomes¹⁰⁵, helping to increase FDI in Australia and create or retain an estimated 27,588 jobs.

As the Commonwealth Government's lead investment facilitation agency, Austrade showcases Australia as a world-class investment destination and identifies specific opportunities for potential investors.

Austrade, in executing this responsibility, focuses on foreign direct investment (FDI) that creates and retains Australian jobs, develops new industries and infrastructure, introduces new technologies and skills, encourages innovation and competition, raises productivity, identifies investors for gaps in potential value chains, and strengthens Australia's overall global economic linkages. FDI covers greenfield investment by foreign companies, joint ventures, partnerships, and research collaborations. It also includes capital investment by investors and funds into Australian companies and projects.

Austrade's overseas network is concentrated in markets where its services will have greatest impact. It operates 84 points of presence in 49 overseas markets, which are grouped into seven regions: ASEAN-Pacific; Greater China; North East Asia; South Asia; Middle East and Africa; Europe; and the Americas. Due to the maturity of their economies, Austrade has historically concentrated its investment promotion and attraction activities in the North American, Western Europe and Japanese markets. In recent years, Austrade has expanded its investment focus to include high-growth and emerging markets, being Greater China, India, ASEAN, South Korea and the Gulf Cooperation Council countries. These regions have a particular sectorial focus on agri-tech, resources and energy, major and tourism infrastructure, and technology.

Austrade's Resources and Energy team co-ordinates all of its activities closely with other Commonwealth Government departments as well as states and territories and relevant industry bodies. Austrade's Resources and Energy team has 13 dedicated staff across its onshore operations. Supported by its offshore network, the team assisted over A\$1 billion of resources investment projects into Australia in 2017.



Austrade's engagement with government departments such as the Department of Industry, Innovation and Science and GeoScience Australia is the centrepiece of the agency's investment attraction strategy. Austrade is currently working in conjunction with other Commonwealth Government agencies to develop the 'Why Invest in Australia' resources narrative. Austrade also partners with federal, state and territory governments on investment attraction at resources events including China Mining and Prospectors & Developers Association of Canada in Canada.

Tax incentives for eligible investors include:

- › A 20 per cent non-refundable carry-forward tax offset on investment, capped at A\$200,000 per investor, per year
- › A 10-year capital gains tax exemption for qualifying investments held for at least twelve months.

Other Programs

The Cooperative Research Centre (CRC) program provides businesses with an opportunity to pursue public-private research collaborations that aim to achieve commercial outcomes. Twenty-two CRCs linked to the resources and energy sector have undertaken collaborations across the world.

Other major programs and initiatives include:

- › **The National Innovation and Science Agenda (NISA)**, announced on 7 December 2015, is an important step to a more innovative and entrepreneurial economy by encouraging early-stage investment from foreign and domestic startups looking to develop ideas in Australia for the global market.
- › **The Industry Growth Centres Initiative** is an industry-led approach driving innovation, productivity and competitiveness by focusing on areas of competitive strength and strategic priority. The Australian Government has already established Industry Growth Centres in key sectors of competitive advantage including those of direct relevance to the lithium-ion battery sector including advanced manufacturing (Advanced Manufacturing Growth Centre – AMGC); mining equipment, technology and services (METS Ignited); and oil, gas and energy resources (National Energy Resources Australia – NERA).

- › **The Exploring for the Future** program led by Geoscience Australia focusses on northern Australia and parts of South Australia to gather new data and information about the potential mineral, energy and groundwater resources concealed beneath the surface. The new pre-competitive data and information will be made publicly available and released over the next three years to support and de-risk resource decision making and investment.
- › **The \$A100 million Junior Minerals Exploration Incentive** provides eligible companies to generate tax credits by giving up a portion of their tax losses from greenfield mineral exploration expenditure. It is capped over four years from 2017-18 and will assist junior exploration companies seeking to raise additional capital for greenfield exploration programs.
- › **Clean Energy Finance Corporation (CEFC)** provides support for developments directly relevant to this energy sector. An example of the funding was an investment of around \$A20 million (\$US15 million) in Pilgangoora project (producing lithium concentrate) led by Pilbara Minerals Ltd. The CEFC's investment in the project will help finance the project's development.
- › **The Northern Australia Infrastructure Facility (NAIF)** offers up to \$A5 billion over five years in concessional finance to encourage and complement private sector investment in infrastructure that benefits Northern Australia. This may include developments in airports, communications, energy, ports, rail and water. The NAIF's investment mandate was recently broadened to cover commercially marginal projects to help stimulate interest in the energy minerals sector.
- › **The Major Projects Approval Agency** provides a single-entry point for regulatory project approvals advice for domestic and international project proponents with an estimated investment of \$A50 million or more, that are of strategic significance to Australia and require Australian Government approval(s).
- › **The Roads of Strategic Importance** initiative funds works on key regional road corridors to support more efficient freight transport. Some A\$3.5 million is being invested over the next decade, including for freight corridors connecting mining projects to transport hubs.
- › The Australian Government provides a discount on the luxury car tax threshold for low emission vehicles. Companies can earn carbon credit units under the Emissions Reduction Fund to transition their fleets to EVs. The CEFC is funding a number of programs that enable the purchase of EVs. The Australian Renewable Energy Agency is also providing financial support for research by ClimateWorks which has partnered with the Electric Vehicle Council.



LIST OF ACRONYMS USED IN THIS REPORT

AMGC	Advanced Manufacturing Growth Centre	LCE	Lithium Carbonate Equivalent
ARENA	Australian Renewable Energy Agency	LCO	Lithium Cobalt
BAM	Battery Anode Material	LFP	Lithium Ion Phosphate
BMS	Battery Management Systems	LIB	Lithium-Ion Battery
CEFC	Clean Energy Finance Corporation	LMFP	Lithium Manganese Iron Phosphate
CSIRO	Commonwealth Scientific and Industrial Research Organisation	LMO	Lithium Manganese Oxide
DSO	Direct Shipping Ore	LTO	Lithium Titanium Oxide
EDR	Economic Demonstrated Resources	Mt	Million tonnes
EPA	Environment Protection Authority	NAIF	Northern Australia Infrastructure Facility
EPBC	Environment Protection and Biodiversity Conservation	NCA	Lithium Nickel Cobalt Aluminium Oxide
EV	Electric Vehicle	NEM	National Electricity Market
FBICRC	Future Battery Industries Cooperative Research Centre	NEPC	National Environmental Protection Council
FDI	Foreign Direct Investment	NERA	National Energy Resources Australia
GDP	Growth Domestic Product	NISA	National Innovation and Science Agenda
GERD	Gross research and experimental development spending	NMC	Lithium Nickel Manganese Cobalt Oxide
GWh	Gigawatt hours	NSW	New South Wales
ICEs	Internal Combustion Vehicle	QLD	Queensland
JORC	Joint Ore Reserves Committee	RDA	Regional Development Australia
JV	Joint Venture	SA	South Australia
Kt	Kilo tonnes	Tpa	Tonne per annum
		VIC	Victoria
		WA	Western Australia

REFERENCES

1. Australian companies are the largest offshore producers of graphite – the remaining major mineral input in lithium-ion batteries.
2. Source: Deutsche Bank, Lithium 101, 9 May 2016.
3. Porteous C, Godfrey B, & Finkel A (2018) "Taking Charge: The Energy Storage Opportunity for Australia" <http://www.chiefscientist.gov.au/2018/07/occasional-paper-taking-charge-the-energy-storage-opportunity-for-australia/> July 2018. ISSN: 2201-0025 (print) and 2201-0033 (online).
4. Deutsche Bank, Lithium 101, 9 May 2016.
5. Deutsche Bank Market Report, Lithium 101, May 2016.
6. Frost & Sullivan, Global Analysis of Battery Materials Market, Forecast to 2023, February 2018.
7. Deutsche Bank Market Report, Lithium 101, May 2016.
8. BMO Capital Markets, Battery Raw Materials – The Fundamentals, 2016.
9. Azevedo M, Campagnol N, Hagenbruch T, Hoffman K, Lala A, Ramsbottom O (2018) Lithium and cobalt – a tale of two commodities, McKinsey&Company. Metals and Mining. June 2018.
10. BMO Capital Markets, Battery Raw Materials – The Fundamentals, 2016.
11. Deutsche Bank, Lithium 101, 9 May 2016.
12. Deutsche Bank, Lithium 101, 9 May 2016.
13. Global Industrial Battery Market, Forecast to 2023, January 2018.
14. Building factories is a basic exercise that requires a business case, capital, commitment and delivery. From financial close on the factory build to first output is generally less than two years. For this reason, longer forward announcements are not normal practice – manufacturers are unlikely to announce a factory build beyond four years out.
15. Deutsche Bank, September 2018.
16. Deutsche Bank, Lithium 101, 9 May 2016.
17. Association of Mining and Exploration Companies.
18. BMO Capital Markets "The Lithium-ion battery and the eV Market" February 2018.
19. BMO Capital Markets "The Lithium-ion battery and the eV Market" February 2018.
20. Benchmark Mineral Intelligence.
21. Australian companies are the largest offshore producers of graphite – the remaining major mineral input in lithium-ion batteries.
22. Australia's Identified Mineral Resources 2017, Geoscience Australia.
23. Australia's Identified Mineral Resources 2017, Geoscience Australia.
24. USGS – <https://minerals.usgs.gov/minerals/pubs/commodity/lithium/mcs-2018-lithi.pdf>
25. Future Smart Strategies (2018).
26. Azevedo M, Campagnol N, Hagenbruch T, Hoffman K, Lala A, Ramsbottom O (2018) Lithium and cobalt – a tale of two commodities, McKinsey&Company. Metals and Mining. June 2018.
27. <http://www.talisonlithium.com/projects>
28. <http://www.galaxyresources.com.au/projects/mt-cattlin>
29. Company data and Credit Suisse "China Lithium Sector" 26 June 2018.
30. Company data and Credit Suisse "China Lithium Sector" 26 June 2018.
31. Company data and Credit Suisse "China Lithium Sector" 26 June 2018.
32. Australia's Identified Mineral Resources 2017, Geoscience Australia.
33. Australia's Identified Mineral Resources 2017, Geoscience Australia.
34. <https://www.bhp.com/media-and-insights/news-releases/2017/07/bhp-invests-a350-million-in-olympic-dam-smelter-operations>
35. Australia's Identified Mineral Resources 2017.
36. Australia's Identified Mineral Resources 2017, Geoscience Australia.
37. <http://www.minara.com.au/about/operations-overview>
38. Geoscience Australia, 2018.
39. <https://www.lincolnminerals.com.au/index.php>
40. <https://renascor.com.au/>
41. Department of Industry, Innovation and Science, Resources and Energy Quarterly, June 2017.
42. Syrah Resources, Battery Anode Material Project, <http://www.syrahresources.com.au/spherical-graphite-project>, 2018.
43. Australia's Identified Mineral Resources 2017.
44. IBIS World Industry Report B0809, Manganese and other mineral mining in Australia, April 2018.
45. <https://mining-atlas.com/operation/Bell-Bay-Manganese-Smelter.php>
46. <http://www.dmp.wa.gov.au/Investors/Iron-Ore>
47. Australia's Identified Mineral Resources 2017.
48. Resources and Energy Quarterly March 2018.
49. <https://www.riotinto.com/iron-ore-158.aspx>
50. <http://www.ga.gov.au/data-pubs/data-and-publications-search/publications/aimr/iron-ore>
51. <http://www.fmgil.com.au/about/fortescue/our-operations>
52. Australia's Identified Mineral Resources 2017.

53. Australia's Identified Mineral Resources 2017.
54. https://www.incitepivot.com.au/~media/Files/IPL/Work%20with%20us/phosphate_hill_leaflet.pdf
55. <http://www.ga.gov.au/education/classroom-resources/minerals-energy/australian-mineral-facts/titanium>
56. Neometals, <http://www.neometals.com.au/reports/2018-07-31-5501-QuarterlyA.pdf>, 31 July 2018.
57. http://www.cristal.com/about-us/Documents/Bunbury_6_15.pdf
58. Resources and Energy Quarterly June 2018.
59. Resources and Energy Quarterly March 2018.
60. Australia's Identified Mineral Resources 2017, Geoscience Australia.
61. Incitec Pivot Ltd (2018) Phosphate Hill https://www.incitepivot.com.au/~media/Files/IPL/Work%20with%20us/phosphate_hill_leaflet.pdf
62. Future Smart Strategies (2018)
63. Frost & Sullivan, Global Analysis of Battery Materials Market, Forecast to 2023, February 2018.
64. Magnis Resources (2018) Agreements signed to fast track Townsville Battery Plant, ASX media announcement by Magnis Resources Ltd, June 5, 2018. <http://magnis.com.au/significant-news/agreements-signed-to-fast-track-townsville-battery-plant>
65. Table 1.1 Outlook for Australia's resources and energy exports, Resources and Energy Quarterly March 2018.
66. Resources and Energy Quarterly March 2018.
67. Deloitte Access Economics "Mining and METS": engines of economic growth and prosperity for Australians, 2017.
68. Deloitte Access Economics "Mining and METS": engines of economic growth and prosperity for Australians, 2017.
69. World Bank (2016) 2016 LPI index.
70. The Global Competitiveness Report 2017–2018, Klaus Schwab, World Economic Forum.
71. Times Higher Education's World University Ranking, 2018.
72. Times Higher Education's World University Ranking, 2018.
73. Deloitte Access Economics analysis, 2015. Based on data provided in The Conference Board Total Economy Database™, May 2015; Austrade.
74. Minerals council of Australia, Miners at work – Australia's world-class mining workforce.
75. Economist Intelligence Unit. "Preparing for Disruption: Technological Readiness Ranking, 2018.
76. CSIRO Annual Report 2016–17; 5. Department of Innovation, Industry and Science, Australian Innovation System Report, November 2016.
77. Austrade Benchmark Report 2018.
78. OECD Dataset: Main Science and Technology Indicators (downloaded on 10 Sep 2018).
79. The Global Entrepreneurship and Development Institute. 2018 Global Entrepreneurship Index.
80. ABS Cat. No. 81580DO001_2016-17 Innovation in Australian Business, 2016-17, Table 1 Summary of innovative activity in Australian business, by status, by employment size, by industry – 2016-17 (Released 19 July 2018).
81. ENERGIA "Electric Vehicles Insights" report prepared for the Australian Energy Market Operator's 2017 Electricity Forecast Insights, Sep 2017.
82. <https://www.csiro.au/en/Research/EF/Areas/Energy-storage/Battery-recycling>
83. International Monetary Fund, World Economic Outlook Database, October 2018; Austrade.
84. International Monetary Fund, World Economic Outlook Database, 2018; Austrade.
85. The Global Competitiveness Report 2018, Klaus Schwab, World Economic Forum.
86. Miller T, Kim A, & Roberts J. 2018 Index of Economic Freedom The Heritage Foundation.
87. ABS 53520 – International Investment Position, Australia: Supplementary Statistics, 2017 (Released 9 May 2018).
88. International Investment in Australia 2017, Department of Foreign Affairs and Trade (DFAT), 2018 <https://dfat.gov.au/about-us/publications/Documents/international-investment-australia-2017.pdf>
89. Benchmark Report, Australian Trade and Investment Commission (Austrade), 2018, <https://www.austrade.gov.au/International/Invest/Resources/Benchmark-Report/charts?RefineModule=114786&retain=true&StartTax=1110&StartDate=&Keywords=&RefineParent=875>
90. Wilhelmus J (2017) Global Opportunity Index: 2017 Global Investors' Growing Focus on Asia. Milken Institute, Sep 2017.
91. Deutsche Bank Market Report, Lithium 101, May 2016.
92. <https://asia.nikkei.com/Companies/BYD-Co.-Ltd>
93. BMO Capital Markets, Battery Raw Materials – The Fundamentals, 2016.
94. <https://steelguru.com/auto/chinese-byd-launches-world-s-biggest-battery-factory/513625#tag>
95. BMO Capital Markets, Battery Raw Materials – The Fundamentals, 2016.
96. <https://asia.nikkei.com/Companies/LG-Chem-Ltd>
97. <https://asia.nikkei.com/Companies/Samsung-SDI-Co.-Ltd>
98. <https://asia.nikkei.com/Companies/PANASONIC-CORPORATION>
99. <https://asia.nikkei.com/Companies/Toshiba-Corp>
100. http://www.toshiba.co.jp/about/press/2017_04/pr1401.htm
101. RDA Australia (2018) Lithium Valley: Establishing the Case for Energy Metals and Battery Manufacturing in Western Australia. ISBN – 978-0-646-98891-7 Lithium Valley.
102. AAP (2018) Sonnen battery manufacturer to set up production plant in SA. <https://www.adelaidenow.com.au/business/jobs/sonnen-battery-manufacturer-to-set-up-production-plant-in-sa-creating-jobs/news-story/371afd78f53b4397e3e4442358e06a57>
103. <https://arena.gov.au/news/simply-energy-build-8mw-virtual-power-plant-adelaide/>
104. Geelong region Local Investment Plan: <https://www.business.gov.au/assistance/regional-jobs-and-investment-packages/geelong-victoria>
105. Annual Report: 2017-2018, Austrade 2018, <https://www.austrade.gov.au/.../1401/Austrade-Annual-Report-2017-18.PDF.aspx>

austrade.gov.au



Australian Government
Australian Trade and Investment Commission

