

Partner of Experts



The Magazine

20

Interesting articles, technical innovations, application examples from all around the world



Weightlifting on the Nil

Technology stands the test in the Egyptian heat

Page 06

Report from Künzelsau

Interview with Patrick Landes, Head of the Spare Parts and Customer Service

Page 10

Mission underground

Wire rope hoists deployed in tunnelling project in Austria

Page 16



EDITORIAL

Dear Reader,

As a strong member of the Columbus McKinnon family, STAHL CraneSystems maintains its status as an internationally successful company. Hoists from Künzelsau set standards, whether this is in the heat of Egypt, under ground in Austria or in the production of air conditioning systems in Canada. On the following pages, we are once again presenting some of the exciting projects that we are realising with our partners. STAHL CraneSystems also attaches great importance to the training and professional development of its employees and partners – you can read about it in the reports on Girls'Day, training and the TechnicalExpertsForum. Anyone who orders a STAHL CraneSystems replacement part receives a package straight from Künzelsau: We've provided you with a glimpse into the Spare Parts Centre, which rounds off our fascinating magazine.

Have fun reading!
Werner Wagner

CONTENT

| | | | | | | | |
|--|---|--|---|---|---|---|--|
| <p>CANADA A breath of fresh air <i>Page 18</i></p> | <p>GERMANY At one klick <i>Page 03</i> The SR wheel block <i>Page 09</i> Report from Künzelsau: Spare Parts Centre <i>Page 10</i> 6th Technical ExpertForum <i>Page 14</i> LogiMAT 2017 <i>Page 15</i> Girls'Day at STAHL CraneSystems <i>Page 21</i> Specially programmed <i>Page 22</i></p> | <p>EGYPT Weightlifting on the <i>Page 06</i></p> | <p>UNITED ARAB EMIRATES Cooperative study modeler in Dubai <i>Page 20</i></p> | <p>NETHERLANDS <i>Page 22</i> 5 cranes for foundry in Egypt</p> | <p>CZECH REPUBLIC <i>Page 04</i> In just 48 hours <i>Page 23</i> Fruitful deployment in Sweden</p> | <p>AUSTRIA <i>Page 16</i> Mission underground <i>Page 22</i> Trade Fair: INTERTOOL & SMART</p> | <p>MALAYSIA <i>Page 23</i> Full power!</p> |
|--|---|--|---|---|---|---|--|



Everything
at one click!

The new STAHL CraneSystems website has gone live.

You've probably noticed already: Our new website, at www.stahlcranes.com, with a new layout and packed full of information, went live in May 2018.

The new responsive design now adapts to your own usage habits. Whether you visit us via your desktop computer, tablet or smartphone, the complete world of STAHL CraneSystems is always within easy reach for you. Naturally, the page can be accessed worldwide not just in German, but also in English, Spanish, French and Portuguese.

From our rich history through current press articles to individual products: the carefully designed information structure allows you to access everything you need to know about STAHL CraneSystems quickly and easily. You can find lots of information about chain hoists, wire rope hoists, explosion protection, engineering, support, people to contact and much more on detailed subpages without needing to click any further – so have fun surfing.

➔ www.stahlcranes.com



In just 48 hours

The new travel carriage was installed on the existing crane in just 48 hours.

SLT components s.r.o., a partner of STAHL CraneSystems, modernises a crane system in the Czech Republic.

Around 200 km east of Prague in Moravská Třebová, REHAU Automotive s.r.o. manufactures injection-moulded and extruded components for the automotive industry. The delicate components must be handled carefully, which is why it became necessary to modernise the existing crane system. In just a weekend, the Czech crane builder SLT components s.r.o., a certified partner of STAHL CraneSystems, equipped the system with two new wire rope hoists from STAHL CraneSystems.



A new travel carriage with an ASF7 as main and an SHF6 as auxiliary hoist was installed on the existing double girder overhead travelling crane.



The REHAU automotive plant in Moravská Třebová has manufactured polymer-based components such as dashboards for various automobile manufacturers since 1994. A double girder overhead travelling crane with a lifting capacity of 32 tonnes and a two-step drive was used in the past to handle the components. This configuration was, however, no longer fit to meet the growing demands for careful material handling. REHAU Automotive therefore contracted SLT components s.r.o. in the summer of 2017 to modernise the system. The new system not only had to move the plastic parts more precisely, but also had to be reconfigurable within a short time – after all, just-in-time production means hard cash in the automotive industry.

Following analysis of the maximum safe working load and foundation of the existing crane runway, SLT components decided to keep these and to install only a new travel carriage. The crab was equipped with an ASF7 wire rope hoist as main hoist and an SHF6 wire rope hoist as auxiliary hoist by STAHL CraneSystems. The ASF7 raised the lifting capacity to 32 tonnes.

The SHF6 auxiliary hoist has a lifting capacity of 20 tonnes. To keep the load on the crane runway and building structure as low as possible and to counteract load swing, the two wire rope hoists are controlled by a frequency inverter. The two hoists can be operated independently of each other and in tandem. They manage a lifting speed of 4 m/min. at a load of 100%.

The workforce of SLT components carried out the demanding replacement of the hoists within just one weekend. It was not necessary to interrupt production operations and REHAU Automotive was able to serve its customers as usual. The reliability of the system also satisfied the customer: shortly after installation, a new contract for delivery of a bridge crane equipped with the same travel carriage and the same wire rope hoists was signed.

SLT components *With the kind support of*
 SLT components s.r.o., Ing. Zbyněk Dvořák

The frequency inverter enables careful lifting and lowering of the loads.





**Weightlifting
on the
Nile**

Madinat al-Aschir min Ramadan

Cairo

Technology from
STAHL CraneSystems stands
the test in the Egyptian heat.

In June 2017 the hoists and components start their journey from Germany to Egypt.



Up to 140 tonnes heavy and up to 40 metres long: the prefabricated concrete parts made by the Egyptian manufacturers ECPC Company are real heavyweights. On top of this come heat and dust – none of which are a problem for the proven technology from STAHL CraneSystems, which does not even work up a sweat in the face of such extreme conditions.

Prefabricated concrete parts are often used to construct the roads and railways. These parts are produced in a precast factory and transported to their destinations once hardened. ECPC Company is one of the leading manufacturers of prefabricated concrete parts in Egypt and is located in Madinat al-Aschir min Ramadan, a town 46 km north-east of Cairo. It manufactures concrete parts for road and tunnel construction as well as concrete pipes for drinking water supply and sewage systems. To serve the growing demands of the Egyptian market, ECPC decided to expand its factory by a new depot with two portal cranes. The contract was awarded to the company ICF International Crane Factory, a certified partner of STAHL CraneSystems, against competition from a French competitor.

The population of Egypt has been growing for decades – by about two million people a year. One of the many challenges this fast population growth poses for the state is overcoming the growing volume of traffic. Although more and more people are using the subsidised railways and metro as means of transport, traffic on the roads is also rising: the number of private cars increased from 2.2 to 3.5 million from 2008 to 2013. On top of this, a large part of freight is transported by road. Egypt is therefore investing heavily in infrastructure projects such as countrywide expansion of roads, bridges and railway lines as well as the metro lines in Cairo and the Nile and Suez Canal waterways.

ECPC Company is one of the largest manufacturers of precast concrete parts in Egypt.





The two AS 7 twin hoists lift concrete parts weighing up to 140 tonnes.



The engineers and technicians of International Crane Factory began planning the installation in March 2017. The hoists and components were manufactured in the STAHL CraneSystems factory in Künzelsau and dispatched on their long journey to Egypt in June 2017. International Crane Factory and STAHL CraneSystems maintained close contact the whole time. International Crane Factory already installed two double girder portal cranes with a span of 32 metres and lifting capacity of 70 tonnes each in July 2017. Each crane is equipped with an AS 7 wire rope hoist in twin implementation with double rail crab. As the ropes of the twin hoist run in opposite directions simultaneously, the concrete parts are lifted and lowered without any sideways movement of the hook and can be positioned exactly. To handle the prefabricated parts, which can weigh up to 140 tonnes each and reach lengths of up to 40 metres, the two portal cranes can be operated individually or synchronously. The cranes are driven precisely with a total of 32 SR wheel blocks and eight

frequency-controlled travel drives. Thanks to the prepared connections, the wheel blocks can be mounted quickly and simply with a head connection.

The reliable technology of STAHL CraneSystems is just the right thing whenever the going gets tough – such as in the hot and dusty environment of Egypt. All components are designed for ambient temperatures up to +45 °C and withstand the harsh conditions effortlessly. Using the standardised, tried-and-tested components from STAHL CraneSystems as basis, it was possible to find a high-performance and maintenance-friendly solution fulfilling all customer requirements optimally. ECPC Company and International Crane Factory are already planning further projects together, for example installation of a new portal crane with a lifting capacity of 6,300 kg.



As the ropes of the twin hoist run in opposite directions simultaneously, the load is lifted and lowered without any sideways movement of the hook and can be positioned exactly.

The SR wheel block from STAHL CraneSystems is truly multi-talented.

Strong and versatile

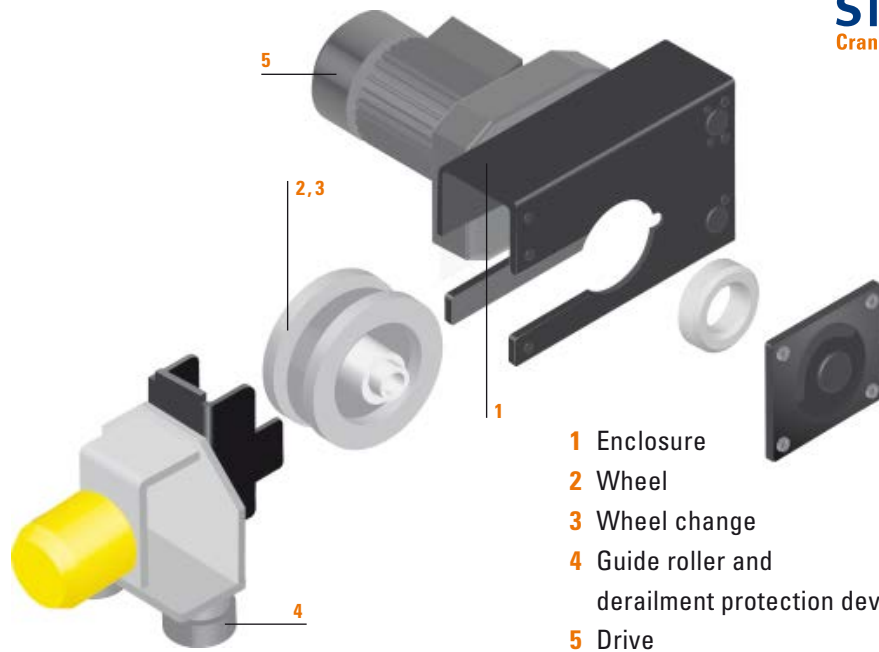

- 1 Enclosure
- 2 Wheel
- 3 Wheel change
- 4 Guide roller and derailment protection device
- 5 Drive

Whether it's for classic crane, trolley and systems building or in custom applications and special constructions: The SR wheel block programme with six different sizes and three standard configurations is ideal for any application to do with moving loads.



The strength of the SR wheel block lies in the cost-effective series manufacture from reliable, low-maintenance standard components. On this basis, six different sizes for wheel loads between 5,000 and 30,000 kg are available. An important feature of the SR wheel block is the simple installation due to the three standardised attachment options for head, welded and inserted connection.

The SR wheel block can be made even safer, more economical and easier to use with a range of mechanical, electrical and electronic add-ons. An angle drive, where the drive is installed at a 90° angle, saves precious space and ensures optimum accessibility even in the tightest conditions. This can be used, for example, with portal cranes or in warehouse technology for driving through narrow gaps. Special options such as guide rollers or a derailment protection device add to the safety of your system.

For out-of-the-ordinary requirements, our engineers will devise special solutions tailored to your needs. If required, the entire wheel block programme is also available in explosion-proof design for Zone 1, Zone 2, Zone 21 and Zone 22.

Application examples

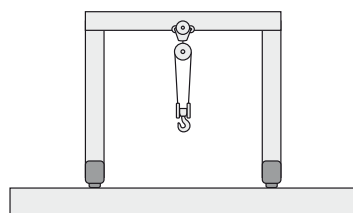

Portal crane

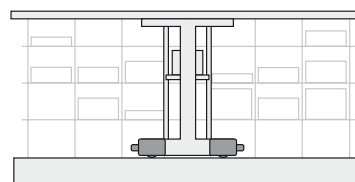

Storage and retrieval machines

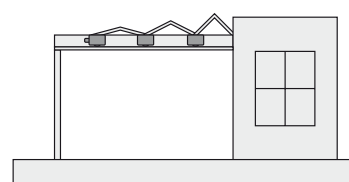

Architectural applications

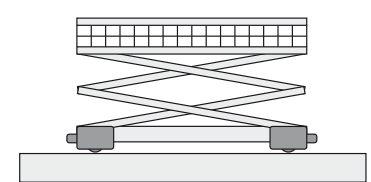

Lifting platforms

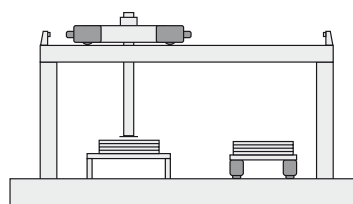

Transport systems

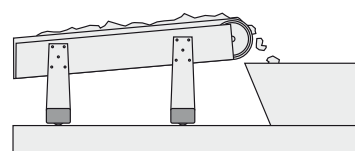

Conveyor systems

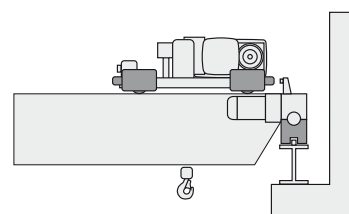

Crane systems

Report from Künzelsau

Interview with Patrick Landes,
Head of the Spare Parts and Customer Service

The Spare Parts Centre at STAHL CraneSystems in Künzelsau is a busy place. Before the gate there are several 40-ton trucks, and the hall is a hive of forklift traffic. The clicking and humming of the automated high-bay warehouse and the packaging machines can be heard. Nevertheless, Patrick Landes finds the time to answer our questions. The head of the Spare Parts Centre is a real expert in the company STAHL CraneSystems: In 1999 he started his training as an industrial mechanic, worked in assembly for a long time - including a year in the subsidiary in Great Britain - and has also spent time in the training department. Since 2010 he has ensured with 20 other employees that STAHL CraneSystems customers around the world receive spare parts reliably.



What is so attractive about working in the spare parts warehouse?

We are the central point of contact for all questions relating to STAHL CraneSystems spare parts and supply original parts all over the world. We ensure that our customers' systems are ready for operation again quickly and stand by as personal contacts. Technical know-how and long experience with our products and in the industry are in demand worldwide. We also constantly work on optimising and modernising our processes in close consultation with our crane building partners and our subsidiaries. This ensures that our work is always interesting and varied.

What are the special features of worldwide shipping?

The delivery of spare parts to various countries is above all an organisational challenge. Every country has its own regulations for shipping and customs. Some countries require a certificate of origin for each part, even for the smallest screw. For shipping to other countries, the country of manufacture must also be indicated on the outside of the packaging. Inside the EU, things are a bit easier, but the tax-free movement of goods entails its own bureaucracy. Each of our employees therefore has specific countries for which he or she is responsible. Nevertheless, everyone has to be informed about current worldwide regulations and specifications in order to support colleagues in case of bottlenecks. In this way we can guarantee the reliable and fast dispatch of spare parts worldwide and reduce the downtimes of our customers to a minimum.



Above:
6,000 spare parts are stored here!
Our photographer takes a look into the
13-metre-high automated warehouse.

Right: Stefan Weidner, team leader of the
spare parts warehouse, and Patrick Landes,
head of the Spare Parts and Customer
Service department.



**We ensure that
our customers' systems
are operable
again quickly.**





How many different spare parts does the department have in stock?

There are 6,000 different parts in the automated warehouse alone. Overall, we have more than 10,000 individual parts in stock, from screws and hook blocks to large gearboxes.

How does a spare part order work?

The orders are digitally recorded by our spare parts order processing system. The system creates a material withdrawal card, which the employees use during picking to know which parts they have to pack. The spare parts are stored in our conventional shelf warehouses and, since 2013, also in our automated high-bay warehouse. It automatically delivers the corresponding containers with the spare parts. A light mark helps the employee to remove the corresponding part. Once everything has been picked, the order goes on to the packaging station and then to dispatch. The package size, weight and delivery note are also automatically calculated and generated by the system.

How long are spare parts available for products from STAHL CraneSystems?

We supply spare parts for all current and past series. Ten years of spare parts delivery for a product is standard in the industry. However, our aim goes far beyond this: we also supply spare parts for hoists 30 to 40 years old. The products from STAHL CraneSystems are very durable and we are proud to be able to supply spare parts even after a long time. We still have some old parts in stock, such as the rope guide for the N wire rope hoist from the 1970s, and others we manufacture from scratch if necessary. For this, we can access our microfilm archive with the old construction plans. Whether a certain part is re-produced depends, among other things, on whether the casting tool is still available or a new one needs to be made. We clarify such cases in close consultation directly with the customer and our production department. An individual post-production of spare parts is usually interesting for our customers until the costs for the production of the required spare parts exceed those for a general overhaul of the crane system.

What will the spare parts department look like in the future?

In the future, technologies such as 3D printing will play an important role. It is now possible to manufacture metal parts using the 3D process, even if this is still very cost-intensive. The 3D printers for metal processing currently cost much more than those for plastic. In addition, the



At the helm: Patrick Landes keeps track of the goings-on in the Spare Parts Centre.

Overall, we have more than 10,000 individual parts in stock.

production of various alloys is still a challenge at present. But as the technology matures and becomes cheaper, the process will become very attractive for the entire metalworking industry. Inventory costs would fall and the production of spare parts would be much more individual for our customers with “print on demand”.



And off you go – well packed and tied-up, the spare parts start their journey all over the world.

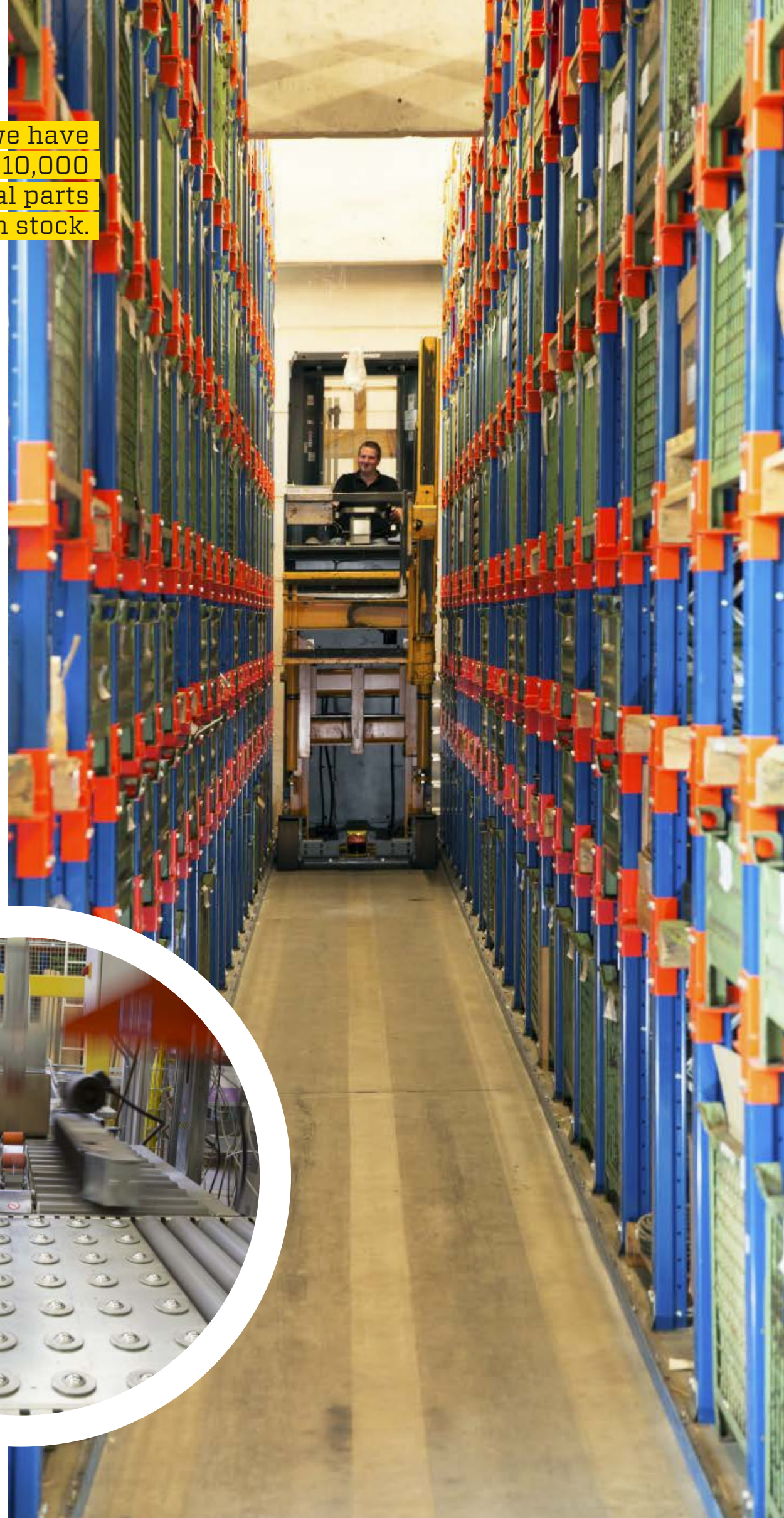



6th TechnicalExpertsForum

STAHL CraneSystems invites crane building partners to the Swabian Mountains

Up along the winding roads of the Albtrauf, past grassy hills, small forests and broad paddocks, you reach the idyllic village of Hohenstein-Ödenwaldstetten. With a population of few more than 500, the hamlet lies in the heart of the Swabian Mountains. Who could expect that up to 45 representatives of the German-speaking crane building partners of STAHL CraneSystems would meet there at Speidels Braumanufaktur from 12-14 March 2018?

Crane building partners from various parts of Germany, Switzerland, the Netherlands, Czech Republic and even Romania travelled to Hohenstein-Ödenwaldstetten for STAHL CraneSystems' 6th TechnicalExpertsForum. They met at midday on 12 March in the pleasing ambience of Speidels Braumanufaktur to share information on the latest developments at STAHL CraneSystems and in the crane building industry as a whole.

The second day of the forum was dedicated to the 16th LogiMAT International Trade Fair for Intralogistic Solutions and Process Management taking place simultaneously at the nearby fair grounds in Stuttgart. There STAHL CraneSystems presented itself with other members of the CMCO Group, namely Yale, Pfaff-silberblau and Magnetek. In the evening the participants learnt about the art of brewing traditional beer in a seminar that left enough time for socialising and conversation.

The next day the crane technology experts got to know the many sides of the Swabian Mountains at Marbach Stud, where the TechnicalExpertsForum closed with presentations on innovations in European standards and the future developments of STAHL CraneSystems.

The abundant attendance, harmonious atmosphere and many interesting talks at the TechnicalExpertsForum make STAHL CraneSystems' convention an important component in its collaboration with international crane building partners, which will be pursued further within the Columbus McKinnon Group.



Partners in motion control

STAHL CraneSystems has been part of the large Columbus McKinnon family since spring 2017. Last year the Künzelsau company still exhibited on its own at the LogiMAT – this year the joint stand with the brands Yale, Pfaff-silberblau and Magnetek testifies to its successful integration into Columbus McKinnon.

By uniting brands such as STAHL CraneSystems, Yale, Pfaff-silberblau and Magnetek, Columbus McKinnon offers an extensive product portfolio under one roof. The immense scope and multitude of possible applications that the range covers became clear at the joint stand at the 16th LogiMAT – International Trade Fair for Intralogistic Solutions and Process Management.

STAHL CraneSystems counts as one of the world's leading manufacturers of hoists and crane components and is the international specialist when it comes to explosion-proof crane technology. The brand Yale of Columbus McKinnon Industrial Products GmbH in Wuppertal is the leading brand in Europe for manual standard hoists. With its Pfaff-silberblau brand, Columbus McKinnon Engineered Products GmbH in Kissing has numbered among the technology leaders in components and system solutions for mechanical drive and hoisting technology for more than 150 years. And Magnetek is America's largest supplier of digital drive systems for industrial cranes and hoists.



The brands presented the perfect synergy between these different products at their stand at this year's LogiMAT 2018. The individual portfolios are supplemented by different focuses and competencies and offer their customers an all-encompassing service.

The dynamic and bright stand presented products and prototypes and invited visitors to explore and try out. Competent staff answered questions and stood by with a wealth of information on the group and all innovations. The booth evening on 14 March gave everyone an opportunity to make new contacts in a relaxed atmosphere of American food and music.

The LogiMAT 2018 was a great joint success for Columbus McKinnon Corporation. With 55,300 visitors and 1,564 exhibitors, the trade fair is one of the most eminent for intralogistics worldwide. Both the number of visitors and exhibitors have grown within three years by 50 and 35 percent respectively. This positive trend should continue next year – of course with STAHL CraneSystems within Columbus McKinnon Corporation.



Mission under- ground

Wire rope hoists from STAHL CraneSystems
deployed in tunnelling project in Austria

The company ACIMEX, at home in the heart of the Loire Valley in France, has offered bespoke solutions in the heavy-duty hoisting sector for 45 years. It specialises in the transportation of objects weighing several tons using air vacuum technology or hydraulic and mechanical grabs. STAHL CraneSystems has regularly equipped these special solutions with durable and high-quality technology since the company's inception. Working closely together, the engineers of the two companies build machines that are used around the world in the construction, metallurgy, aviation and energy industries.







In Semmering, Austria, a 27.3 kilometre long railway tunnel between Gloggnitz in Lower Austria and Mürzschlag in Styria is set to pass under the northern Alps as from 2026. For the machines in use here, ACIMEX ordered three identically constructed wire rope hoists from STAHL CraneSystems to adjust the precast elements picked up by the segment erectors exactly. The SHF 5020-40 wire rope hoists with 1/1 reeving and a length of 2 were manufactured in the company's Künzelsau plant. For this application, the customer required an above-average lifting speed, which was achieved by using a hoist controller with frequency inverter and motor encoder for closed-loop control. The closed-loop control, combined with software, makes it possible to compare the actual speed of the hoist with the set speed and to adjust it if necessary. In this way lifting speeds of 8 to 12 metres per minute can be achieved. The frequency inverter further enables smooth acceleration and deceleration movements during the lifting process.

STAHL CraneSystems delivered the hoists to ACIMEX in April 2017. The successful and timely completion of the machines once again illustrates the fruitful collaboration between the two companies.

With the kind support of CBE GROUP, Isabelle Richomme

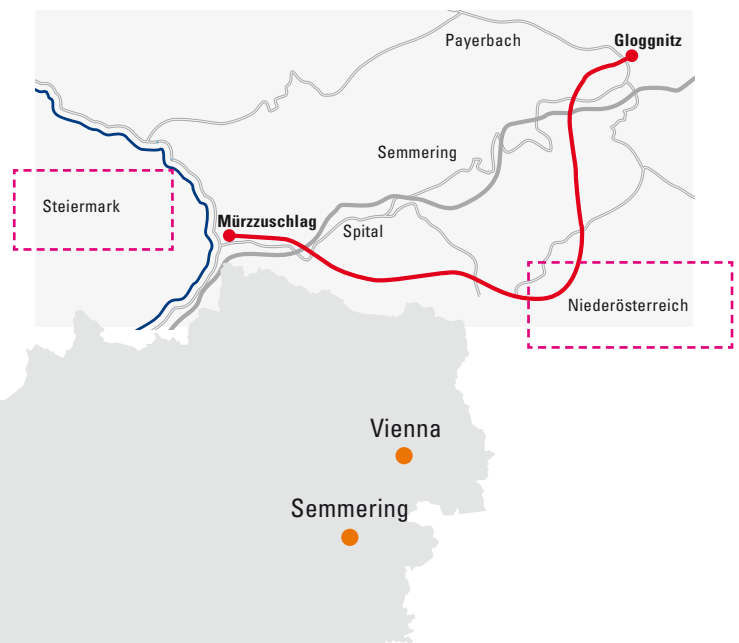
Tunnelling requires strong and reliable machinery to ensure safe construction of the tubes. To this end, ACIMEX manufactures segment trolleys and segment erectors that handle the individual precast elements at the tunnel construction site: the segment trolley, fitted with a vacuum lifter, grips and lifts the segments from the service train and transports them deeper inside the tunnel. There they are picked up by segment erectors with the help of an air vacuum and placed in their final position. Fitted with two lateral rubber suction cups fastened underneath the chassis and a central vacuum pump, the ACIMEX segment erector can turn the elements in X, Y and Z-direction by up to 360°. Parts weighing up to 20 tonnes are lifted in this way to the highest possible position and placed with a precision of $\pm 5^\circ$. The hoisting technology that performs this work often comes from STAHL CraneSystems.





Montreal

A breath of fresh air

STAHL CraneSystems hoisting technology for Canadian air handling equipment manufacturer

Ventrol Air Handling Systems Inc. is a brand of Nortek Air and one of Canada's leading suppliers of innovative customised air handling equipment. Ventrol has been supplying high-quality products and services for a wide range of air handling applications since 1998. The company produces certified ventilators, coils and individually made air handlers in its own factory in Montreal, Québec. With eight employees initially, Ventrol has expanded in just twenty years to 400 employees and a factory area of 150,000 square metres. With its takeover by the US Nortek Air Solutions group, the decision was made to expand the factory building in Montreal in order to increase production on site.

STAHL CraneSystems is represented in Canada by CanStahl Inc.. Since 2009, CanStahl Inc. has built an exceptional partnership in the province of Québec with the crane building and service company Groupe Industriel Premium Inc. This partnership is even stronger now with the addition of the construction company Structures Industrielles Premium Inc. Within this group customers can be offered turn key solutions which consist of integrated solutions from customised crane technology through to building modifications for the safe installation of hoisting technology.

These advantages were used by Ventrol Air Handling Systems Inc. for the expansion of its operating site: 18 new single girder overhead travelling cranes were required, 15 of which were to work in tandem with two hoists. Alongside headroom, quality and delivery on time, the pricing was a major criterion for the customer, Ventrol Air Handling Systems Inc., in its decision to work with PREMIUM INDUSTRIAL Groupe. In a trial run with a prototype in the CanStahl Inc. factory hall, the clients were able to see the high quality and reliability of the products for themselves before placing the order: All the bridge cranes were equipped with high-quality STAHL CraneSystems components.

In North America, indoor cranes are traditionally fitted with wire rope hoists. However, to be able to lift the load in tandem operation without any sideways movement of the hook, to ensure a small space between the load hooks and to keep the approach dimension on both sides of the crane bridge to a minimum, this generally standard strategy was reviewed, and chain hoists were used instead of the more usual wire rope hoists. CanStahl thus took over the use of chain hoists for deployment with low loads from Europe for the Canadian market.

In total, 35 new chain hoists with a lifting capacity between 2,000 and 5,000 kg were installed. The spans of the bridge cranes are up to 20.12 m. The lifting height of the individual hoists is between 6 and 8 m. The cranes are each equipped with a 12-button radio transmitter, which communicates with the three receivers for crane movement and the two hoists with tandem operation. This efficient layout of the controls means that there is no need for the cable trailing systems for the control cables.

The large store on site, the easy working relationship with CanStahl and the flexibility of the implementation impressed the customer, Ventrol Air Handling Systems Inc., across the board. After the commissioning of the 35 chain hoists, further joint projects are now planned, such as the replacement of older lifting equipment in the Montreal factory by STAHL CraneSystems products.

With the kind support of PREMIUM INDUSTRIAL Groupe, Alain Leclerc

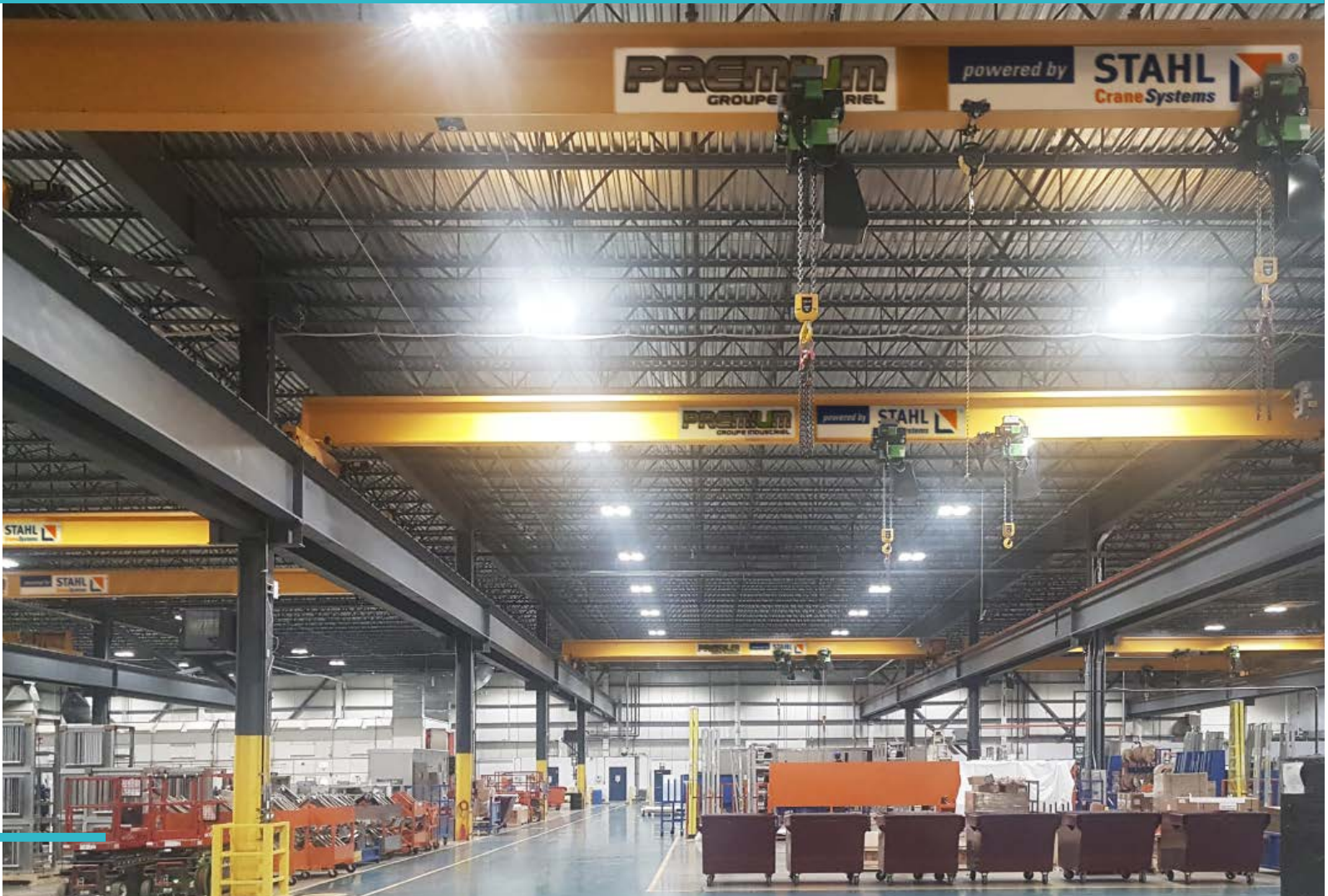

3 birds with one stone



At STAHL CraneSystems, Daniel Kaluza is combining training, study and time abroad.

Daniel Kaluza is studying at the Künzelsau campus of the Reinhold Würth University. In the cooperative study model, he is combining vocational training to become an electronics engineer with a university course to become a Bachelor of Science (Electrical Engineering) and will thus gain two qualifications in just five years. In his practical semester, Daniel Kaluza was also able to gain experience abroad at STAHL CraneSystems FZE on the Persian Gulf.

“The cooperative study model is just the right thing for me”, says Daniel Kaluza. “After gaining my university entrance qualification, I wanted to do something practical first, so starting with the training to become an electronics technician for equipment and systems is perfect.” The trainees go through almost all the departments at STAHL CraneSystems, which gives them a great insight into the company and its products. “The training course was full of variety, and I kept on learning new things. I really love the family working atmosphere at STAHL CraneSystems. There’s a nominated person in each department you can always turn to”, Daniel Kaluza continues.

Training then transitions seamlessly into university study: “The first semester at University was really demanding, as I took the final training examination at the same time.” During the degree course, Daniel Kaluza spends his time away from lectures in Electronics Development at STAHL CraneSystems. All of the fifth semester of the degree course is spent gaining practical experience in the training company. Daniel Kaluza was able to spend 2 months of this in the company’s subsidiary STAHL CraneSystems FZE in the United Arab Emirates, where he passed through various areas of the company, exploring the Engineering Department in Dubai and also learning, in particular, about sales. Language barriers were soon overcome and, thanks to the favourable location of his apartment near both the office and the beach, the dry heat of Dubai was not a problem for this young student, “though I did miss a bit of greenery sometimes”.



We can do it!

Curious girls discover technical professions

On Girls' Day each year, companies, businesses and universities throughout Germany open their doors to school girls in Class 5 (~ 11 years) and above. Here, girls are introduced to training careers and degree courses in IT, manual trades, sciences and technology where women have so far been under-represented and meet female role models in leadership positions in industry and politics.



The 2018 Girls' Day at STAHL CraneSystems was soon booked up! Six schoolgirls were given an insight into the production of hoists at the headquarters in Künzelsau, the various training professions such as electronics technician for operating technology or industrial electrician and the degree in mechanical engineering at STAHL CraneSystems. And then it was time to get "hands on". In the practical session, the girls were able to experience electrical technology for themselves by using soldering irons, circuit boards and LEDs to assemble a retro "ping-pong" game, complete with sound, operating elements and coin insertion. Everyone was delighted – and maybe we'll be welcoming back one or two of them as an apprentice or student!



Specially programmed

BRUNNHUBER KRANE, Germany

BRUNNHUBER KRANE supplied two identical single girder overhead travelling cranes, each with two wire rope hoists and a lifting capacity of 3.2 tonnes (1.6 t + 1.6 t), for the galvanising hall of a hot dip galvanising plant. The wire rope hoists can be moved individually or in tandem. For safety reasons, the crane systems are fitted with an obstacle avoidance control: When the crane is moving slowly, the crane bridge is automatically positioned at the entrance to the galvanising room and the crane movement is blocked at the same time. The crane bridge can only move on when the travel carriages have come out of the galvanising room or blocked area. With a special coating, control cabinets and C-rails in stainless steel and safety conductor lines with sealing lip and admission pressurisation, the cranes are superbly adapted for use in an aggressive, corrosive environment.



INTERTOOL & SMART Automation

Austria, 15-18 May 2018

In 2018, two trade fairs for manufacturing and automation technology were held at the same time: INTERTOOL and SMART Automation Austria. STAHL CraneSystems was represented on the joint CMC0 stand.



From
around
the
World

5 cranes for foundry in Egypt

CraneSolutions B.V., Netherlands



Our Dutch partner CraneSolutions B.V. was awarded the contract to fit out an iron foundry in Alexandria back in 2013. After a few delays due to the difficult political situation in Egypt, the foundry finally started operation in March 2018. In total, five SH wire rope hoists with working loads between 3.5 and 16 tonnes plus three ST chain hoists are used in two buildings. Hall 1 contains two double girder overhead travelling cranes for handling the scrap iron and the molten metal and for maintenance work. The three cranes have a span of 20.4 m and run on the same crane runway. Each one can take on the task of the adjacent crane, which avoids production down times. In the second hall, the metal parts are cast and finished, and a double girder overhead travelling crane with a span of 22.9 m and a portal crane with a span of 3.5 m are used for this. Three ST chain hoists were also installed at various stations such as tool change and sand blasting. The commissioning client, Dutch company Gemco Engineers B.V., is very happy with STAHL CraneSystems products and the work done by CraneSolutions B.V.. Further joint projects are already being planned.



Full power!

EXCELLIFT, Malaysia



STAHL CraneSystems partner EXCELLIFT from Malaysia delivers crane systems not only to South East and Central Asia, but also to South America. In May 2018, EXCELLIFT installed a double girder overhead travelling crane with an AS 7 with a 60-tonne lifting capacity in a power plant in Colombia. An SH wire rope hoist with a lifting capacity of 20 tonnes serves as auxiliary hoist.



Fruitful deployment in Sweden

Adamec Crane Systems, Czech Republic



The Norwegian company Yara International manufactures chemicals and industrial gases such as fertilisers, urea, nitrates and ammonia. At its plant in Köping (Sweden), 150 km east of Stockholm, an AS 7 wire rope hoist with a lifting capacity of 120 tonnes is used on a double girder overhead travelling crane. In addition, an SHR 6 wire rope hoist with a lifting capacity of 16 tonnes has also been installed. The crane has a span of 12.4 m and was installed by STAHL CraneSystems partner Adamec Crane Systems from the Czech Republic.

Information literature

Copy, fill in, fax

Company _____

Name _____ Department _____

Address _____

Telephone _____ Mail _____

You can find this and other brochures at www.stahlcranes.com/download
We will gladly also send them to you by post.



The ST chain hoist
No. of pages: 28
 DE EN ES
 FR NL NO
 PT CS RU
 ZH



The SH wire rope hoist
No. of pages: 24
 DE EN ES
 FR NL PT
 CS RU ZH



The AS7 wire rope hoist
No. of pages: 28
 DE EN ES
 FR NL PT
 RU ZH



Crane Technology
No. of pages: 28
 DE EN ES
 FR NL PT
 RU ZH



SR wheel block
No. of pages: 8 Seiten
 DE EN ES
 FR



Expertise in explosion prot.
No. of pages: 28
 DE EN ES
 FR NL PT
 RU ZH NO

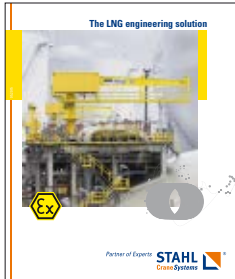

The LNG engineering solution
No. of pages: 16
 DE EN ES
 FR RU NO

DE: German, EN: English, ES: Spanish, FR: French, NL: Dutch,
PT: Portuguese, RU: Russian, ZH: Chinese, NO: Norwegian, CS: Czech

Presented by

STAHL CraneSystems GmbH
Daimlerstr. 6, 74653 Künzelsau, Germany
Tel +49 7940 128-0, Fax +49 7940 55665
marketing.scs@stahlcranes.com
www.stahlcranes.com

a member of **COLUMBUS MCKINNON**
CORPORATION

Partner of Experts

