

**THE MEPKIN ABBEY SHIPWRECK:
DIVING INTO MEPKIN PLANTATION'S PAST**

A Thesis

by

SUSAN LYNN VEZEAU

Submitted to the Office of Graduate Studies of
Texas A&M University
in partial fulfillment of the requirements for the degree of

MASTER OF ARTS

August 2004

Major Subject: Anthropology

**THE MEPKIN ABBEY SHIPWRECK:
DIVING INTO MEPKIN PLANTATION'S PAST**

A Thesis

by

SUSAN LYNN VEZEAU

Submitted to Texas A&M University
in partial fulfillment of the requirements
for the degree of

MASTER OF ARTS

Approved as to style and content by:

Kevin J. Crisman
(Chair of Committee)

Donny L. Hamilton
(Member)

Charles E. Brooks
(Member)

David L. Carlson
(Head of Department)

August 2004

Major Subject: Anthropology

ABSTRACT

The Mepkin Abbey Shipwreck:

Diving into Mepkin Plantation's Past. (August 2004)

Susan Lynn Vezeau, B.S., College of Charleston

Chair of Advisory Committee: Dr. Kevin J. Crisman

When discovered by sport divers in 1970, the Mepkin Abbey shipwreck was immediately reported to the South Carolina Institute of Archaeology and Anthropology (SCIAA). The wreck was first investigated in 1980, and a preliminary report was published in 1981. The shipwreck is now part of 'The Cooper River Underwater Heritage Trail,' established in 1998. SCIAA archaeologists theorized that the wreck was the sloop *Baker*, owned in the late 1700s by American patriot and Mepkin Plantation owner Henry Laurens.

This thesis includes a description of the field research, drawings of the vessel, a scantling list, and a discussion of the artifacts recovered from the site which provided clues dating the vessel to the second quarter of the 19th century. The historical background of Mepkin Plantation is described, with a focus on how the craft may have been utilized. Finally, the thesis compares the wreck with other documented vessels from the same region and period, specifically: the Brown's Ferry vessel, Clydesdale Plantation sloop, and Malcolm boat.

DEDICATION

I would like to dedicate this thesis to my maternal grandmother, Cora Jane Eanes Dillon, for a lifetime of continuous love and support and for giving me an excellent example of what an independent woman should be.

ACKNOWLEDGEMENTS

Many thanks to all those that helped to make this project a reality: Dr. Kevin Crisman for his guidance and support; Dr. Lynn Harris for being a mentor and friend; the SCIAA underwater staff of Chris Amer, Jim Spirek, Joe Beatty, and Carl Naylor for their professionalism and their kindness; Doug Boehme and George Pledger for teaching me the ropes of “black water” diving; Lou Edens for allowing me to stay in her beautiful plantation home; the SCIAA Archaeological Research Trust for financial support; Barbara Merchant for her editorial assistance and for always making me laugh; and especially Drew Ruddy for his excellent documentation and his years of dedication.

I would also like to thank my family: my parents, Jerry and Jackie Vezeau, for their never ending love and encouragement; my children, Brian and Jazmyn Beck, for being my inspiration; and most of all, my wonderful husband, Steve Edelman, for sharing the journey and bringing peace and beauty into my life.

TABLE OF CONTENTS

	Page
ABSTRACT	iii
DEDICATION	iv
ACKNOWLEDGEMENTS	v
TABLE OF CONTENTS	vi
LIST OF TABLES	viii
LIST OF FIGURES.....	ix
INTRODUCTION.....	1
1980 Field Research	1
Historical Background.....	7
2000 and 2001 Field Research	10
ANALYSIS OF ARTIFACTS	22
DESCRIPTION OF THE MEPKIN ABBEY VESSEL	40
Described from Archaeological Data.....	40
Reconstruction of Missing Elements from Comparative Sources	53

	Page
COMPARATIVE ANALYSIS	61
The Brown's Ferry Vessel.....	61
The Clydesdale Plantation Sloop	64
The Malcolm Boat.....	67
Analysis.....	71
CONCLUSIONS.....	76
The Function of the Mepkin Abbey Vessel	76
Interpretations.....	77
Recommendations	81
REFERENCES.....	83
APPENDIX A SCANTLINGS OF THE MEPKIN ABBEY WRECK (Metric).....	86
APPENDIX B SCANTLINGS OF THE MEPKIN ABBEY WRECK (Imperial).....	88
APPENDIX C MEPKIN ABBEY SHIPWRECK HULL CALCULATIONS	91
VITA	94

LIST OF TABLES

TABLE	Page
I Dimensions of Four Early Vessels from the Carolina Low Country	72
II Woods Used in Ship Construction.....	74

LIST OF FIGURES

FIGURE	Page
1 Map of the Cooper River.....	2
2 The Mepkin Abbey Site	3
3 The 1980 Wreck Plan.....	4
4 The Stem	5
5 The Stern Post	6
6 Underwater Heritage Trail Buoy Marker at the Site of the Mepkin Abbey Shipwreck.....	11
7 Forward Section of the 2000 Preliminary Site Plan.....	14
8 After Section of the 2000 Preliminary Site Plan.....	15
9 Two Views of the Stem.....	16
10 Two Views of the Mast Step.....	17
11 The Rudder Assembly.....	18
12 Lines of the Mepkin Abbey Plantation Vessel.....	19
13 Construction Drawings of the Mepkin Abbey Plantation Vessel	20
14 The 1970 Discovery Dive Team	24
15 Jug 1	25
16 Jug 2	26
17 Jug 4	27
18 Jug 6	28

FIGURE	Page
19 Jug 8	29
20 Jug 9	30
21 Jug 10	31
22 Jug 7	32
23 Jug 3	33
24 Jug 5	34
25 Brother Stephen Petronek Holding Jug 1	36
26 Jug 10, Close-up Showing ‘SWAINE’ Maker’s Mark	38
27 The Final 2000 Site Plan of the Mepkin Abbey Wreck	41
28 Excavated Starboard Side of the Malcolm Boat	56
29 The Brown’s Ferry Research Model	59
30 Recovery of the Brown’s Ferry Vessel	62
31 Construction Plan and Interior Profile of the Brown’s Ferry Vessel	63
32 Section Drawing of the Brown’s Ferry Vessel.....	64
33 Remains of the Clydesdale Plantation Sloop	64
34 Section Drawing of the Clydesdale Plantation Sloop	66
35 Lines of the Clydesdale Plantation Sloop	67
36 Malcolm Boat’s Mast Steps	68
37 Malcolm Boat’s Surviving Transom Planking.....	69
38 Reconstruction of the Malcolm Boat with a Gaff Rig	70
39 Capacity of the Malcolm Boat	79

INTRODUCTION

On the southeastern coast of the United States, just inland from Charleston, South Carolina, two men discovered a shipwreck while diving in the west branch of the Cooper River (Figure 1) in June 1970. Later that week one of the men, eager to explore, returned to the site with additional help. The shipwreck was located just offshore from the Mepkin Abbey (Figure 2), which had once been the Mepkin Plantation. The remains of the old plantation dock were still there, now underwater, not far from the shipwreck. The old wooden wreck's primary cargo seemed to be planks, but the divers also recovered ceramic jugs, bottles, and hammers. The divers reported the wreck--and their finds--to the South Carolina Institute of Archaeology and Anthropology (SCIAA).

1980 Field Research

In November 1980, the wreck was surveyed by a team from SCIAA. They spent two weeks researching the site, recording with a depth sounder, measuring the hull (Figure 3), and collecting wood samples. Mapping was done on a preliminary basis and many details were left unrecorded at this time. The stem (Figure 4) was recorded and the team recovered the entire stern assembly, which included the stern post, stern knee, rudder stock, and the rudder blade (Figure 5). The stern assembly was conserved in Columbia, South Carolina along with the remains of the Brown's Ferry vessel. The recording and subsequent analysis indicated that the Mepkin Abbey shipwreck was a southern built vessel. The wood from the hull was primarily live oak, with a keelson of

This thesis follows the style of *The International Journal of Nautical Archaeology*.

southern yellow pine, and trenails of bald cypress. The surviving hull was 48 feet (14.63 m) in length, with a beam of 11 feet (3.35 m). It was tentatively dated to the early part of the 19th century based on the ceramics recovered from inside the wreck (Wilbanks, 1981). The ceramics consisted of 11 stoneware jugs; other finds recovered from the site included two three-piece mold bottles and two hammers. Dating the vessel on the basis of these artifacts was considered problematic; the river is not a stable environment and the shipwreck can act as a strainer, trapping materials moving in the current.

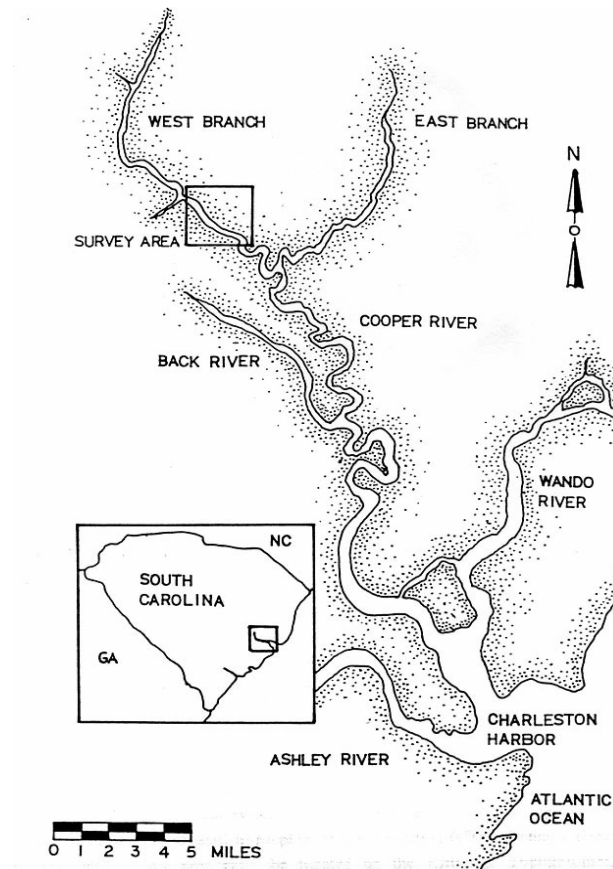

Figure 1. Map of the Cooper River (drawing by Scott Heavin, courtesy of SCIAA).

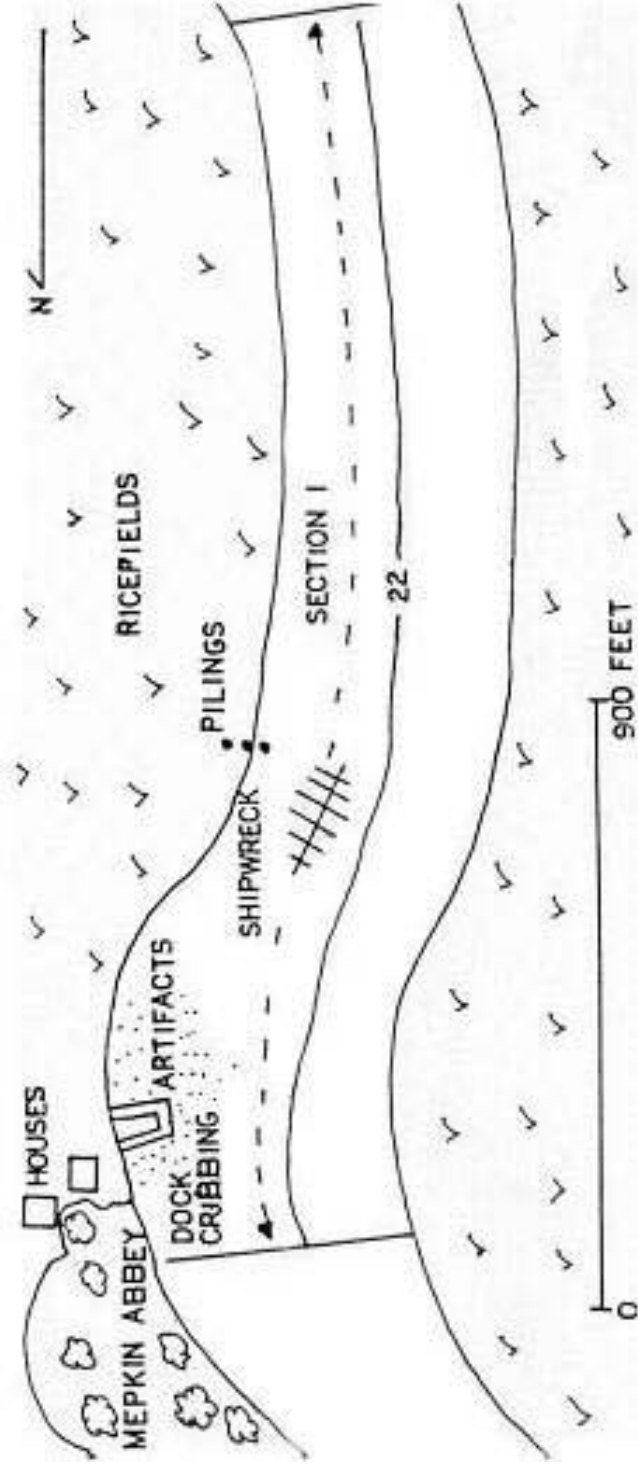

Figure 2. The Mepkin Abbey Site (drawing by Lynn Harris, courtesy of SCIAA).

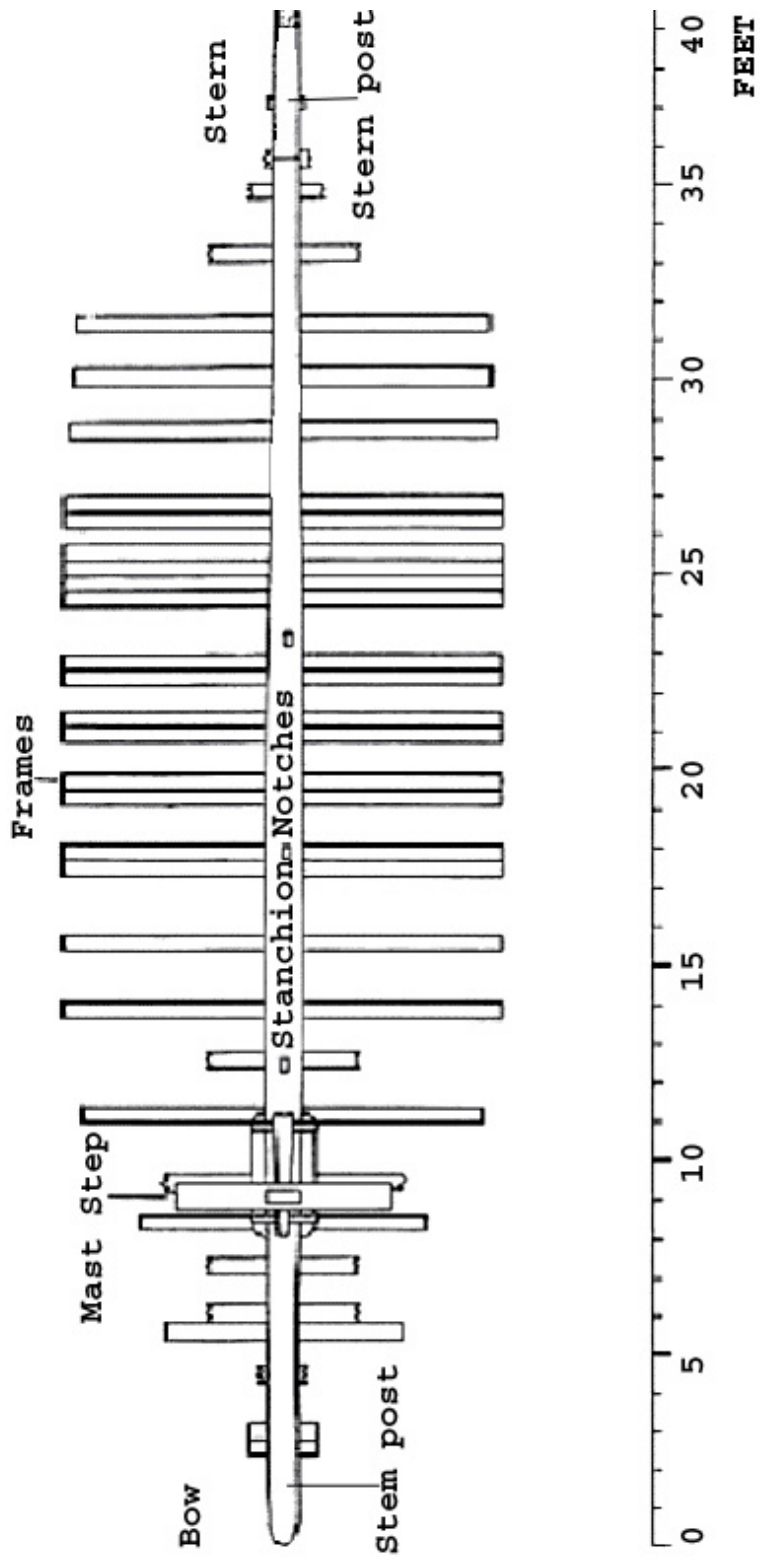

Figure 3. The 1980 Wreck Plan (drawing courtesy of SCIAA).

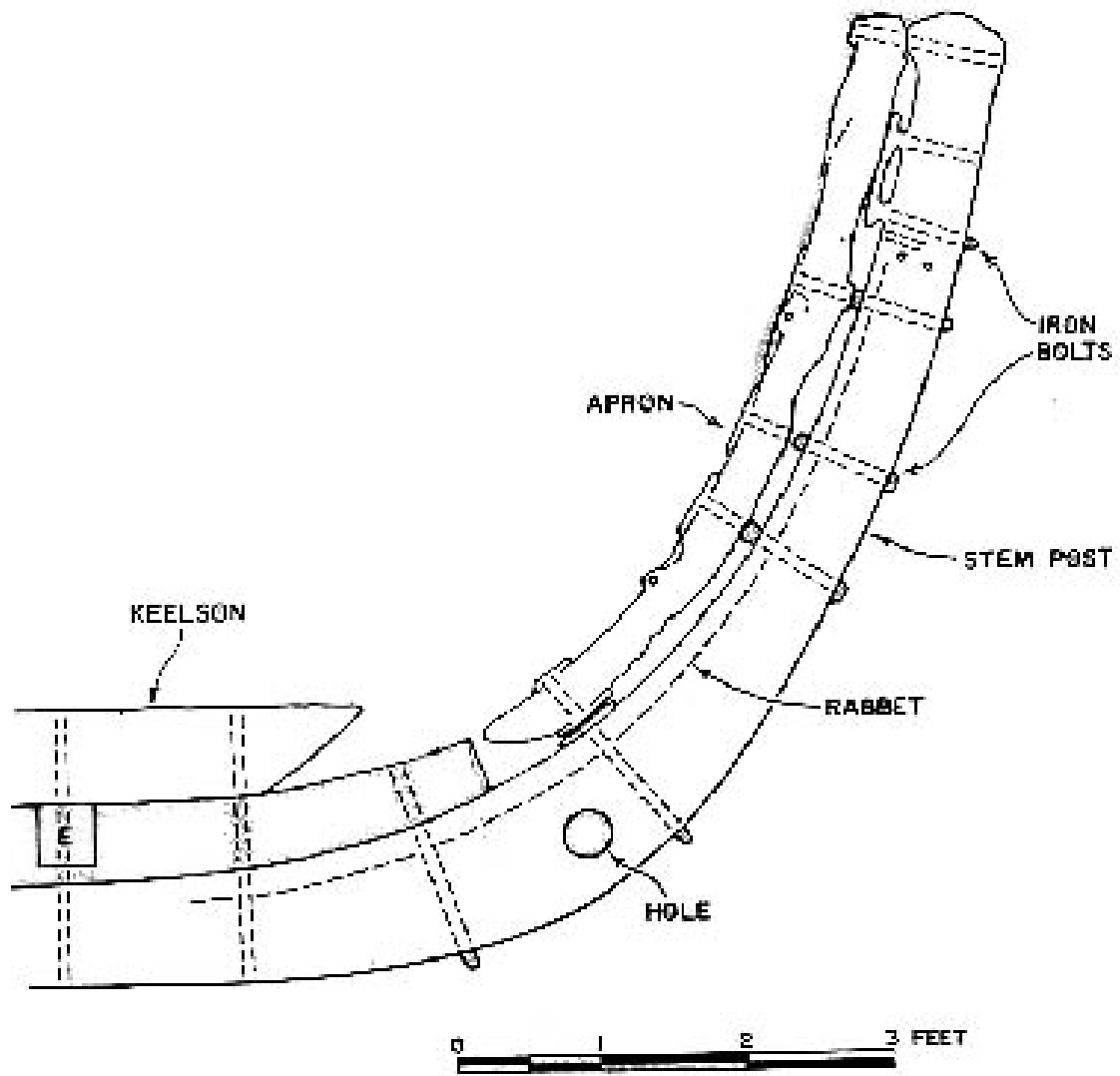

Figure 4. The Stem (drawing by Darby Erd 1980, courtesy of SCIAA).

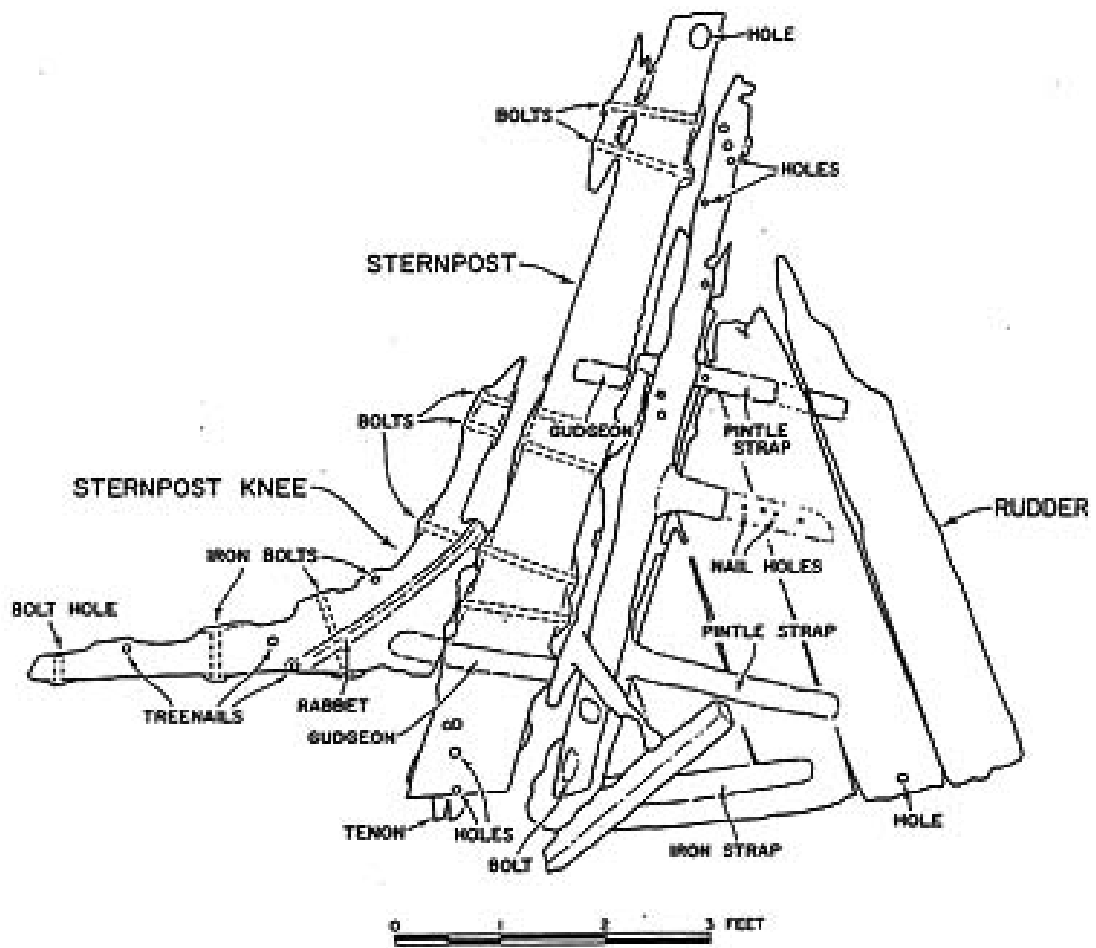

Figure 5. The Stern Post (drawing by Darby Erd 1980, courtesy of SCIAA).

Historical Background

Historical sources were consulted to see if a vessel of this size had ever been registered or reported sunk in the vicinity of the Mepkin plantation. During the mid to late 18th century, Mepkin plantation belonged to the wealthy and respected Henry Laurens, a dedicated American patriot and one of the signers of the Declaration of Independence. Born in Charleston, South Carolina in 1724, Laurens died at Mepkin plantation in 1792. He was president of the first and second Councils of Safety 1775-1776; president of the first Provincial Congress of South Carolina in 1775; vice president of South Carolina in 1776; and president of the Continental Congress 1777-1778. Laurens was elected Minister Plenipotentiary to Holland in 1779, and was captured at sea while sailing to fulfill that mission during the American Revolutionary War. He was the only American prisoner of war to be confined in the Tower of London. After 15 months he was released in exchange for Lord Cornwallis who was captured along with his army at Yorktown in 1781. In 1783, Henry Laurens, along with John Jay, John Adams, and Benjamin Franklin, represented the United States and signed the peace treaty in Paris that brought an end to the Revolutionary War (Chesnutt and Taylor, eds., 1999).

Henry Laurens' career had a less-savory aspect: he earned his vast wealth as a trans-Atlantic merchant, and slaves were one of his most profitable cargoes. He was one of the largest owners and importers of African slaves of his period. Laurens invested his money in rice plantations, and staffed them with hand-picked slaves. Over time he became one of the wealthiest men in America. His Mepkin Plantation was a success,

and even after his death it continued to produce rice under the yoke of slavery. The plantation was handed down, father to son, and remained in the Laurens family until the middle of the 19th century when the property was transferred to the South Carolina Society for \$900 per year on a lease/sell agreement (Charleston County Book of Deeds L12:517). Much of this is described in *The Papers of Henry Laurens*, edited by Philip M. Hammer and George C. Rogers, Jr., and published for the South Carolina Historical Society by the University of South Carolina Press (1981).

The papers also inform us that Henry Laurens owned a vessel called the *Baker*, which belonged to the Mepkin plantation and traveled between the plantation and the port city of Charleston. In 1763 the overseer of Mepkin arranged for a schooner (probably the *Baker*) to be built as a plantation boat. In a 1766 Mepkin estate inventory, the *Baker*, with four slave crew members, was valued at 2,600 pounds (Hammer and Rogers, eds., 1981; vol. 6, p. 613). In 1771 Laurens ordered that the *Baker* be converted from a schooner into a single masted sloop, for in his travels north he had seen similar vessels that had been converted to this rig. He wrote that by converting the schooner to a sloop the ‘Labor and Expence of at Least one Man is saved by such Rigging’ and that there would also be ‘some Advantage gained in Point of Sailing’ (Hammer and Rogers, eds., 1981; vol. 7, p. 566 footnotes).

The *Baker* is discussed a number of times in letters written to Henry by his brother James. On October 19th 1773, James noted:

The *Baker* is so much out of repair that I expect it will cost a great sum to put her in order. But as there is near 400 cord of Wood ready for her I must put her into the hands of Tweed & Mr. Rose promises to Look into her & make the best agreement he can for you (Hammer and Rogers, eds., 1981; vol. 9, p. 126).

One month later, on November 30th, James stated:

I have but lately got the *Baker* out of the Carpenters Hands & now it appears that her bottom is so bad, that it remains a Doubt whether she will swim with a Load of Wood which she is gone to make tryal of. It was the Carpenter's opinion, that to Give her a new Bottom & thorough Repair would be as Expensive as to Build a new Vessel, & besides that she would not have been finish'd for this Season. Therefore I thought it best to Defer that. If it proves unfit for Service, I must endeavor to sell the Wood which is Cut at the Landing (Hammer and Rogers, eds., 1981; vol. 9, p. 183).

On December 22nd 1773, James wrote:

I have had Sam & 7 Negro fellows from Mepkin this fortnight Past Repairing the Dam & laying down two new trunks to let off the Water...I send them back tomorrow in the *Baker* (who brings her Cargo notwithstanding her Worm eaten Bottom) very well taking care not to Load deep (Hammer and Rogers, eds., 1981; vol. 9, p. 204).

Finally, on July 19th 1774, Laurens concluded:

Your Schooner *Baker* is now unfit for service & I could not Venture to put her into the Carpenter's hands as Tweed assur'd me it would be as Expensive to repair her as to build a New Vessel of Equal Burthen. I mention'd this formerly but you did not give me any directions about repairing or Purchasing another (Hammer and Rogers, eds., 1981; vol. 9, p. 513).

The location of the shipwreck and the letters from the papers of Henry Laurens all pointed to the possibility that the Mepkin Abbey shipwreck was the *Baker*. Because of the historical importance of Henry Laurens, it was tempting to link the Mepkin Abbey vessel to him. Furthermore, the Mepkin Abbey shipwreck showed signs of modifications to its mast step which fit with Laurens' directions to convert the schooner into a sloop. Even if it was not of Henry Laurens' era, the wreck may have been a vessel owned by the Laurens family as the plantation remained in their possession for generations.

Upon Henry Laurens' death in 1792, Mepkin plantation passed into the hands of

his oldest living son Henry (Harry) Laurens (1763-1821), and Harry, when he died, left the plantation to his son John Ball Laurens (1799-1827). John had a son, also named John Ball Laurens (1824-1865), who inherited Mepkin plantation at the death of his parents when he was only 4 years old. The younger John Ball Laurens, the fourth generation of Laurens' to own Mepkin, relinquished the plantation to the South Carolina Society on April 25, 1851. The terms of the sale called for the Society to make payments under a lease agreement until the final sale price of \$9000.00 was paid in full in 1855. At that time, the title to Mepkin was officially transferred (Charleston County Book L12, p. 517).

Mepkin belonged to the Laurens family for 93 years, from 1762 when Henry Laurens bought the plantation, until his great grandson John Ball Laurens signed over the title in 1855. During this entire period rice was the primary crop, and river travel the main means of transportation. This was true not only at Mepkin, but throughout the South Carolina Low Country. Whether or not the Mepkin Abbey shipwreck was once Henry Laurens' *Baker*, or the plantation vessel of one of his family members or even that of a neighbor, the importance of the vessel is considerable: It is an archaeological link to South Carolina's maritime, agricultural, and commercial heritage.

2000 and 2001 Field Research

SCIAA's Underwater Archaeology Division used the Mepkin Abbey shipwreck as a field training site for several years. Because the state has an active hobby diver program and the Cooper River is the state's most heavily dived inland waterway, in fall 1998 SCIAA and the Parks, Recreation and Tourism Division of South Carolina opened

the 'Underwater Heritage Trail' in the Cooper River. The Mepkin Abbey shipwreck became an official site on the trail (Figure 6). In order to improve knowledge of the shipwreck site, a grant was obtained from the SCIAA Archaeological Research Trust for field research to be conducted in the summer of 2000.



Figure 6. Underwater Heritage Trail Buoy Marker at the Site of the Mepkin Abbey Shipwreck (photo by Sue Vezeau).

The 2000 field research objectives were to: 1) conduct historical research on the vessel; 2) complete detailed recording of the hull construction; 3) stabilize and reconstruct the shipwreck (sections of the hull removed for study in 1980 were to be returned to the site); and 4) photograph and videotape the site.

The SCIAA research grant contained funding for a graduate student intern, and I was invited to come to Charleston and help with the field research. Funding provided by the Institute of Nautical Archaeology and Texas A&M University also supported my

participation in this research.

The wreck lies beneath 20 to 30 feet (6.1 to 9.1 m) of black water. The term 'black water' refers to water that has the appearance of dark tea, a result of cypress trees releasing tannic acid into the river. Visibility in this water is usually low to nonexistent. The river's powerful current makes it feasible to dive only during an incoming tide. The tide creates a six-hour flow in each direction, and the water level changes by approximately six feet (1.8 m) with each tidal change. We had to wait at the dock until the tide had risen enough to float the dive boats. On a typical day this left us with about a four-hour window of dive time.

Two weeks of field research were carried out in the summer of 2000 by the SCIAA crew, which was when the majority of the documentation was completed. An additional expedition was scheduled for a week in October to complete the work. I arrived for the final three days in October of the 2000 project. The weather held with prevailing temperatures in the upper 70s and water temperature in the mid to upper 60s. This, along with the shallow depth (no more than 30 feet or 9.14 m) of the wreck, allowed us to dive comfortably in wet suits using compressed air. Two divers used Argo masks to communicate with those on board the dive boat while taking hull recordings.

My primary purpose was to obtain hull curvatures with a digital goniometer borrowed from the Texas A&M Nautical Archaeology Program. Lynn Harris, Ph.D. (SCIAA's nautical archaeologist in Charleston), directed the dive team. Carl Naylor (SCIAA's technical assistant), Jim Spirek (another of SCIAA's nautical archaeologists), a number of volunteer divers (including George Pledger, Doug Boehme, and Drew

Ruddy), and I comprised the crew. As well as getting the hull curvatures, we tried to fill in any gaps left over from the summer's research. Much had already been accomplished as evidenced by the preliminary site plan that I was given (Figures 7 and 8).

We elected to bring up the stem (Figure 9) and the mast step (Figure 10) to photograph and record on board our dive boat then return them to their original locations. The stern assembly, in storage at a nearby plantation, was also re-recorded and photographed (Figure 11). I made copies of all field notes and upon my return to Texas A&M University, began an analysis and interpretation of the hull. This included preparation of ship's lines based on the wreck plan (Figure 12), frame curvatures, historical data, development of a scantling list in both imperial and metric measurements (Appendices A and B), and the creation of construction drawings (Figure 13) that included an interior profile, a deck plan, and a section drawing specifically chosen to highlight the saddle mast step. The reconstruction of the ship was based not only on the wreck plan, frame sections, and related research conducted in 2000, but also on the preliminary report written in 1981 from the 1980 field work.

Ralph Wilbanks, in his 1981 report tells us that, 'in November 1980, the Division of Underwater Archaeology at the Institute spent two weeks surveying the wreck. Only six days were utilized in actually measuring the wreck' (151). During this two-week period, wood samples were taken from the wreck and sent in for analysis, and the stern post knee, stern post, and rudder assembly were raised and transported to Columbia, South Carolina for conservation. These were conserved by SCIAA conservators along with the timbers from the Brown's Ferry vessel.

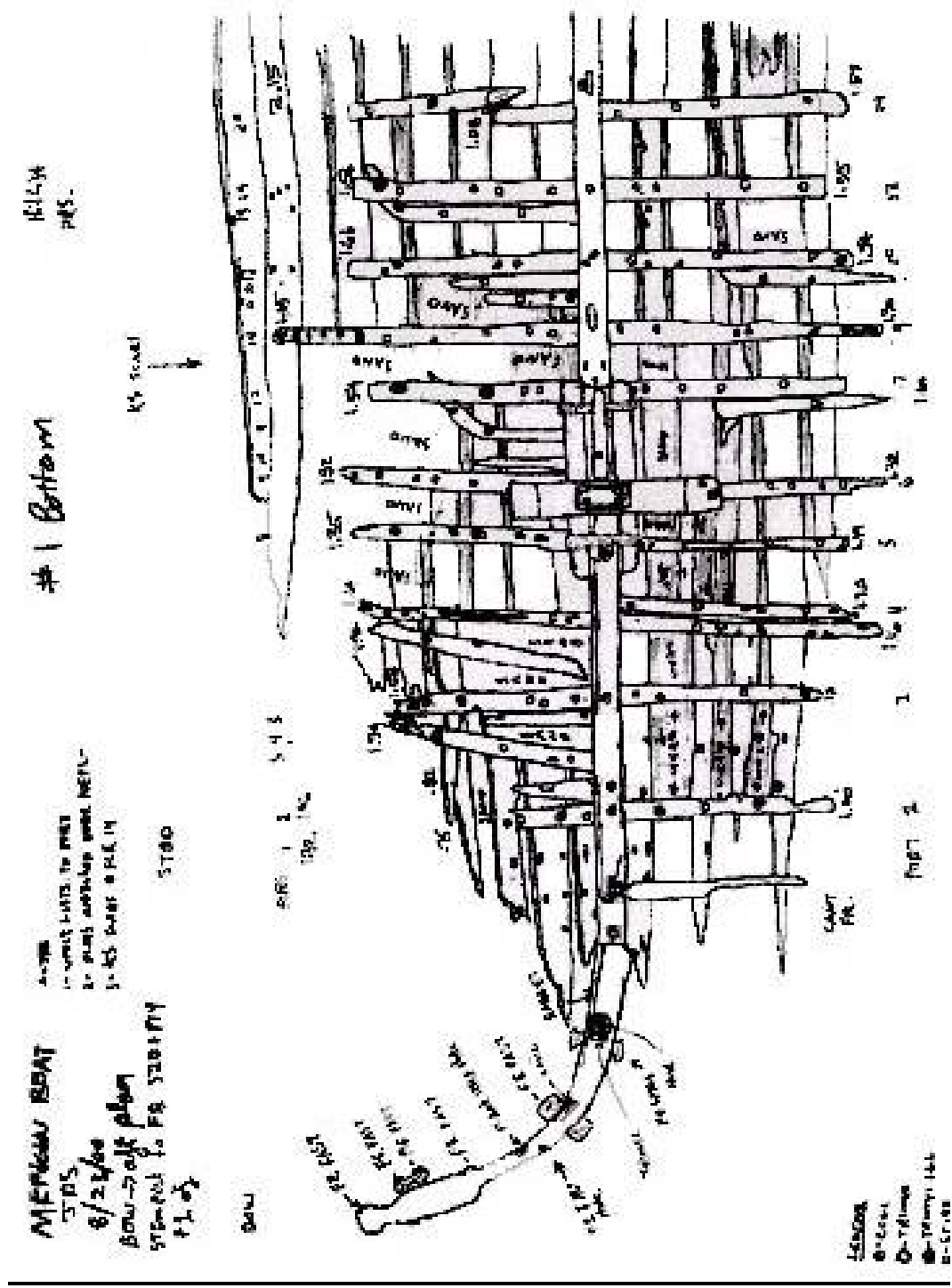

Figure 7. Forward Section of the 2000 Preliminary Site Plan (drawing by Jim Spirek, of SCIAA). This drawing is a reproduction of the actual field notes drawn underwater and illustrates legibility.

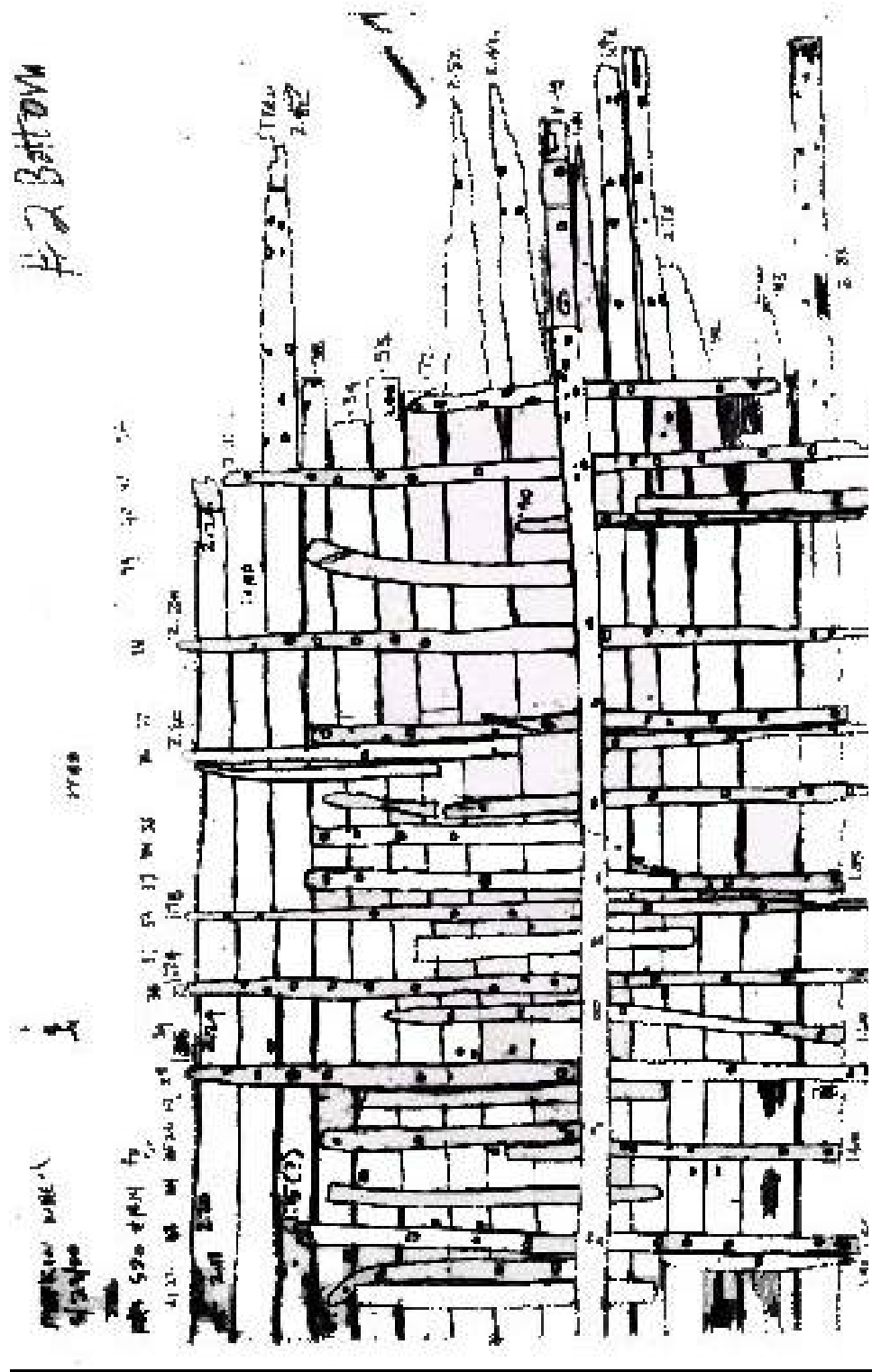

Figure 8. After Section of the 2000 Preliminary Site Plan (drawing by Jim Spirek, courtesy of SCIAA). This drawing is a reproduction of the actual field notes drawn underwater and illustrates legibility.



Figure 9. Two Views of the Stem (photographs taken October 2000 by Sue Vezeau). The complete stem is shown at top and a detail of the base and the keel scarf is shown in the lower photo.

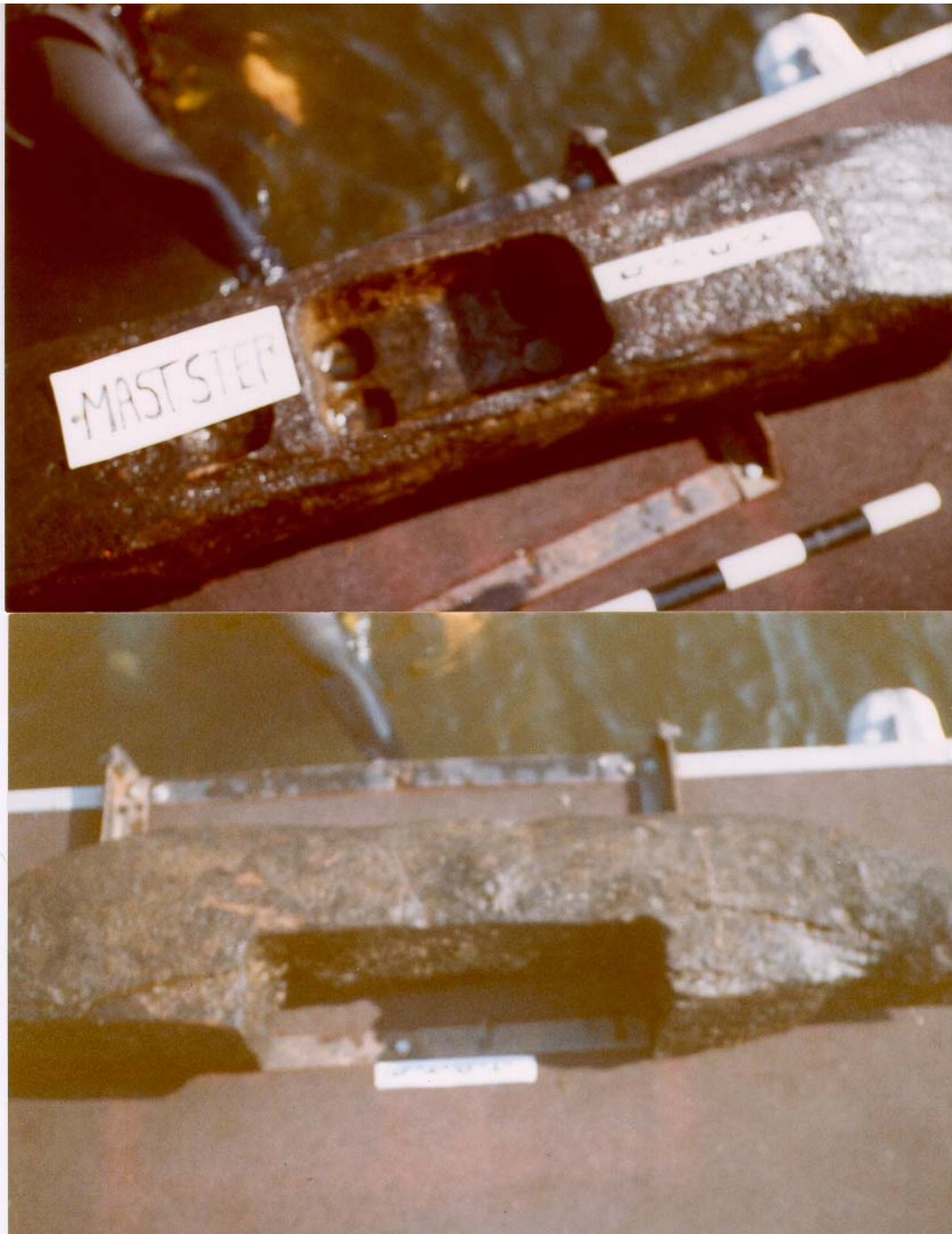

Figure 10. Two Views of the Mast Step (photographs taken October 2000 by Sue Vezeau). The upper photo shows the top of the mast step including a view of the auger holes inside the step itself. The lower photo is a profile view showing how the mast step was designed to fit over the keelson.

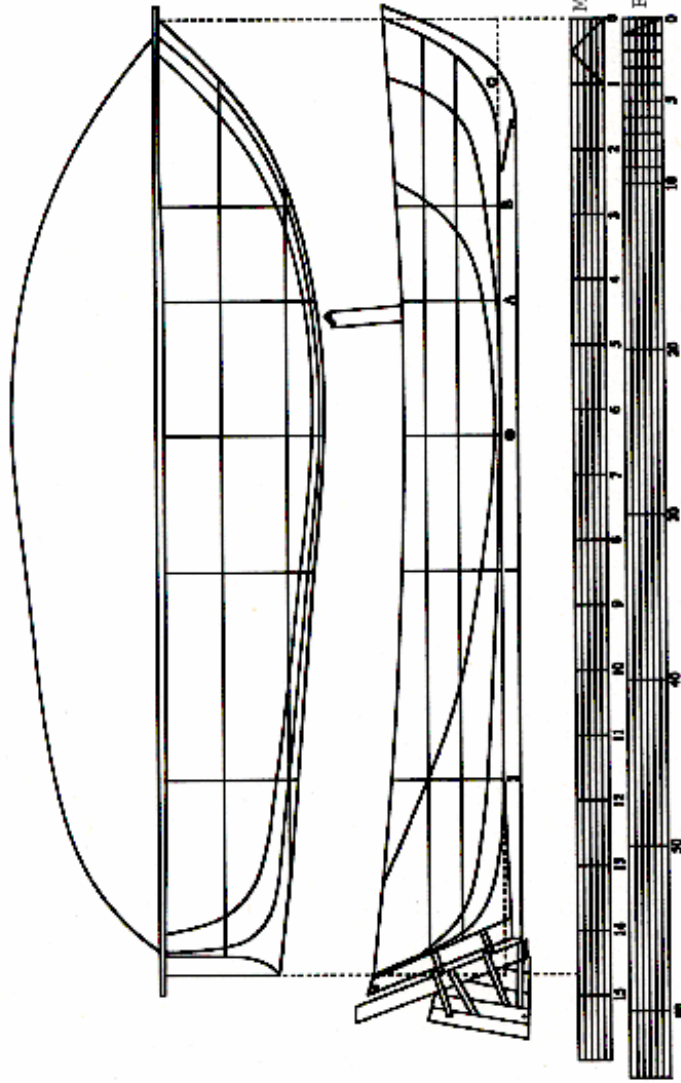
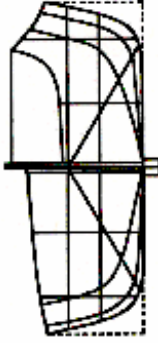

Figure 11. The Rudder Assembly (photograph taken October 2000 by Sue Vezeau).

**MEPKIN ABBEY
PLANTATION VESSEL**

Preliminary Reconstruction
From Lines Taken off the Hull
in 1980 and 2000

Reconstructed Dimensions
Length Overall 14.71 M
Moulded Beam 5.12 M
Maximum Draught .9 M
23.65 Tons



SCALE 1:30

Part No. 100

Figure 12. Lines of the Mepkin Abbey Plantation Vessel (reconstructed and drawn by Sue Vezeau).

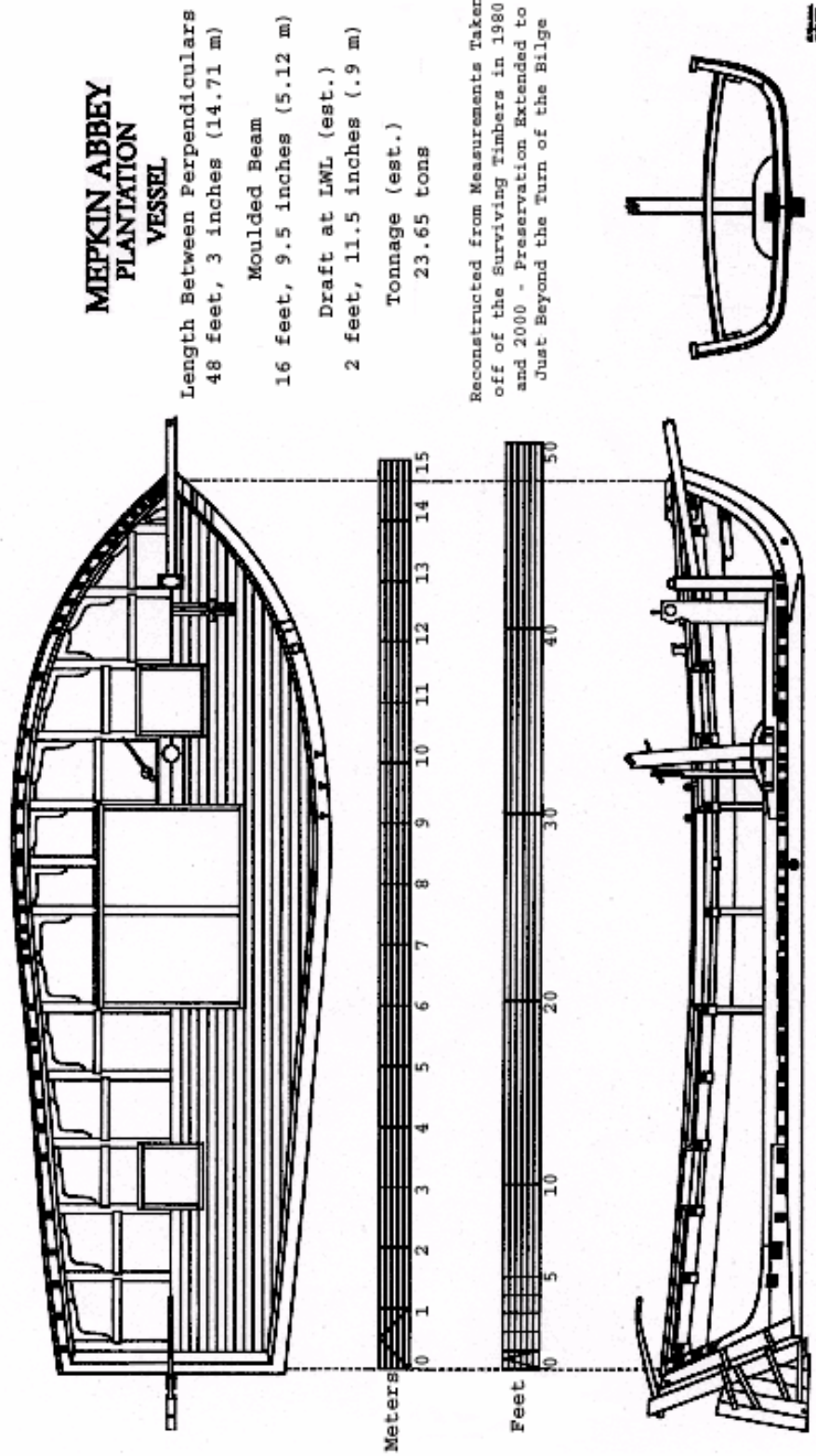

Figure 13. Construction Drawings of the Mepkin Abbey Plantation Vessel (reconstructed and drawn by Sue Vezeau).

Once the field notes were analyzed, new questions emerged. Consequently, another field expedition was conducted in 2001. The SCIAA crew from the previous expedition, along with volunteer divers Ronnie Rogers, Drew Sorrel and I dove on the Mepkin site May 7 and 11; between those dates, we excavated and recorded another site on the shipwreck trail. During our two days of recording, we took additional hull measurements and photographed the rudder assembly in situ (It had been reconstructed and replaced on the wreck the previous week.)

I spent May 12-14 doing historical research at the Charleston County library and the Charleston Museum. I also interviewed Drew Ruddy, one of the original discoverers of the Mepkin Abbey shipwreck. Drew was a true asset to this project, for he kept excellent records of the artifacts recovered from the site and undertook historical research on his own. Together we visited the local Moncks Corner library and the Mepkin Abbey, where Drew introduced me to Father Aelred Hagen and Father Francis Kline, Abbot of Mepkin Abbey.

ANALYSIS OF ARTIFACTS

Our knowledge of the wreck's discovery and its artifacts is largely based on the work of Drew Ruddy, one of the first divers on the wreck and the compiler of 'Abstracts Concerning the Mepkin Boat Wreck' (Personal Communication, 2001). In this document Ruddy explains that the wreck was initially discovered by Robert 'Captain Bob' Densler who was taking a friend, Don Hayes, out for his first diving experience in June 1970. Their dive had to be aborted just after the wreck was found, but Densler contacted Ruddy and another dive partner, Julian 'Muck' Muckenfus, who agreed to try and relocate the wreck the following Saturday. The three divers returned to the site and prepared to dive, along with Densler's father, Robert 'Papa D' Densler Sr. who would stay aboard and tend the boat. Ruddy described the experience:

Upon arriving at the site Bob very carefully aligned his range markers and dropped his anchor reporting that we should be over the wreck. I very eagerly geared up and jumped into the water and descended on the anchor line. Upon arriving on the bottom I found that I was on the frames of the wreck. I began to swim forward and almost immediately found a stoneware jug lying just within the wreck on the port side. Upon recovering the jug I ascended the anchor line and handed it to Papa D. All were excited by the find and after returning to the bottom I soon heard Bob and Muck in proximity on the wreck. I began to slowly swim around the outer parameters of the wreck. It had a very impressive bow stem which curved up into the current. As I progressed down the starboard side, I began to hear Bob screaming into his regulator. Thinking that he might be in some kind of trouble, I began to swim to the middle of the wreck to assist him. The interior of the wreck aft of the mast step was loaded with what appeared to be a cargo of wood of varying and assorted sizes. Bob was on top of the pile of wood, approximately amidships reaching down and pulling out stoneware jugs and setting them on top of the heap. I took two of the jugs and swam to the surface and handed them into the boat. I repeated this process for all seven of the stoneware jugs which Bob found buried in the cargo of wood. Upon completion of the dive, we learned that Muck had recovered one additional stoneware jug forward of the mast step in the bow area. Also two mid 19th century three-piece

mold bottles and two hammers were recovered. I can't say at this time who recovered these objects or exactly where they were found. During the course of this dive, Bob removed some wood from inside of the wreck. He found no additional artifacts and a substantial cargo of wood remained in the wreck. I do not remember any upper structure of the wreck being in place. The stern post and rudder were not in place. We found no other types of artifacts that day and there was no indication of any of the ship's rigging or tackle.

His firsthand account of the discovery of the artifacts substantiates that these items were indeed located in situ and were not arbitrarily placed there by tide or current. It is very doubtful if a large collection of stoneware jugs would have been found intact in any situation where they were not well protected.

The original discovery yielded nine stoneware jugs, two bottles, and two hammers. The recovery team took a group photo with the artifacts. The photo shows the bottles and all of the jugs, but none of the hammers (Figure 14). Two additional jugs were recovered from underneath the pile of wood on a subsequent dive that took place the following year, bringing the total to 11 stoneware jugs. According to Ruddy, the pile of wood was originally over four feet (1.22 m) high and occupied the space from just aft of the mast step to the front of the stern post. The pile contained fence posts and other odd shapes. Densler removed much of it in 1970 and 1971; the SCIAA team cleared out the rest to facilitate a study of the hull during the 1980 excavation.

A final glass bottle recovered at that time was described as 'missing the neck which was not found on board the wreck. The body of the bottle was free-blown and appeared to have been from the late 18th or early 19th centuries;' free-blown bottles are generally dated prior to 1860 (Ruddy, Personal Communication, 2001). The first mold-made bottles were produced in 1814 and the process was patented in 1822 (Hume, 1991:

61). The bottles in the photograph, described by Ruddy as three-piece mold bottles, would have been made sometime between 1814 and 1885. No further documentation exists on the bottles, and their current location is unknown.



Figure 14. The 1970 Discovery Dive Team (from left: Drew Ruddy, Julian Muckenfus, Captain Bob Densler, and Robert Densler Sr.) (photo courtesy of Drew Ruddy).

Of the 11 stoneware jugs, 10 were well photographed and documented before being distributed to various locations by their owners. Jug 11, which was broken, was not photographed and was awaiting repair at the time the rest of the collection was

recorded. Subsequent research has relied upon these photographs because none of the jugs were available for study in 2001.

Those jugs located in 1970 include one located by Drew Ruddy (Figure 15), six located by Bob Densler (Figures: 16, 17, 18, 19, 20, and 21), and one located by Julian Muckenfus (Figure 22). Two additional jugs were located in 1971 by Bob Densler (Figures 23 and 24).

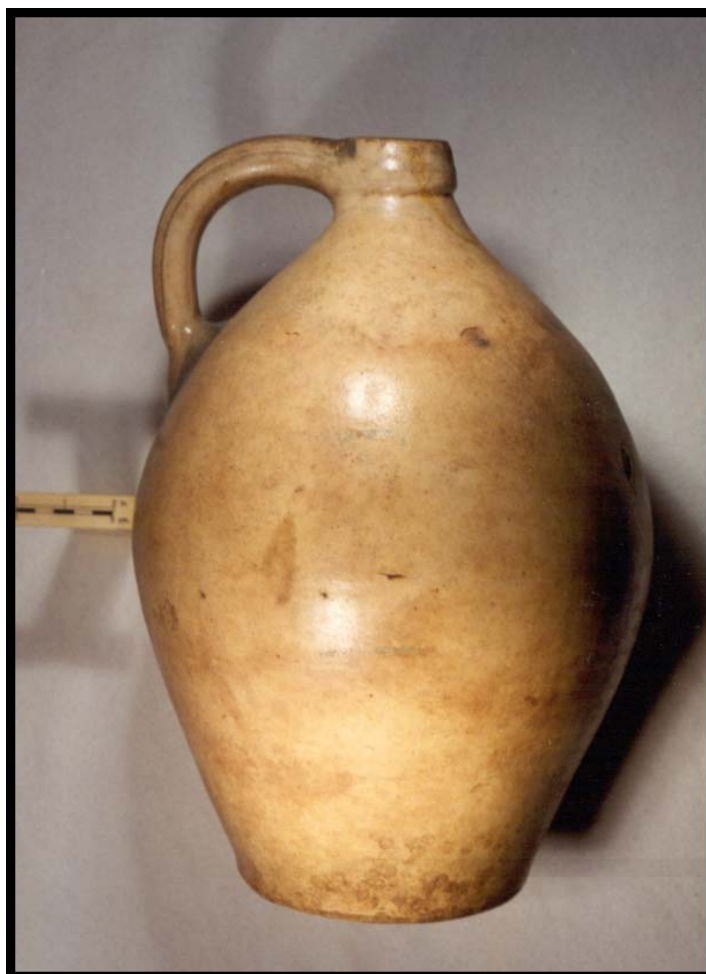

Figure 15. Jug 1. Located in 1970 by Drew Ruddy from the portside amidship (photo courtesy of Drew Ruddy).



Figure 16. Jug 2. Located in 1970 by Bob Densler from just aft of the mast step under the cargo of wood (photo courtesy of Drew Ruddy).

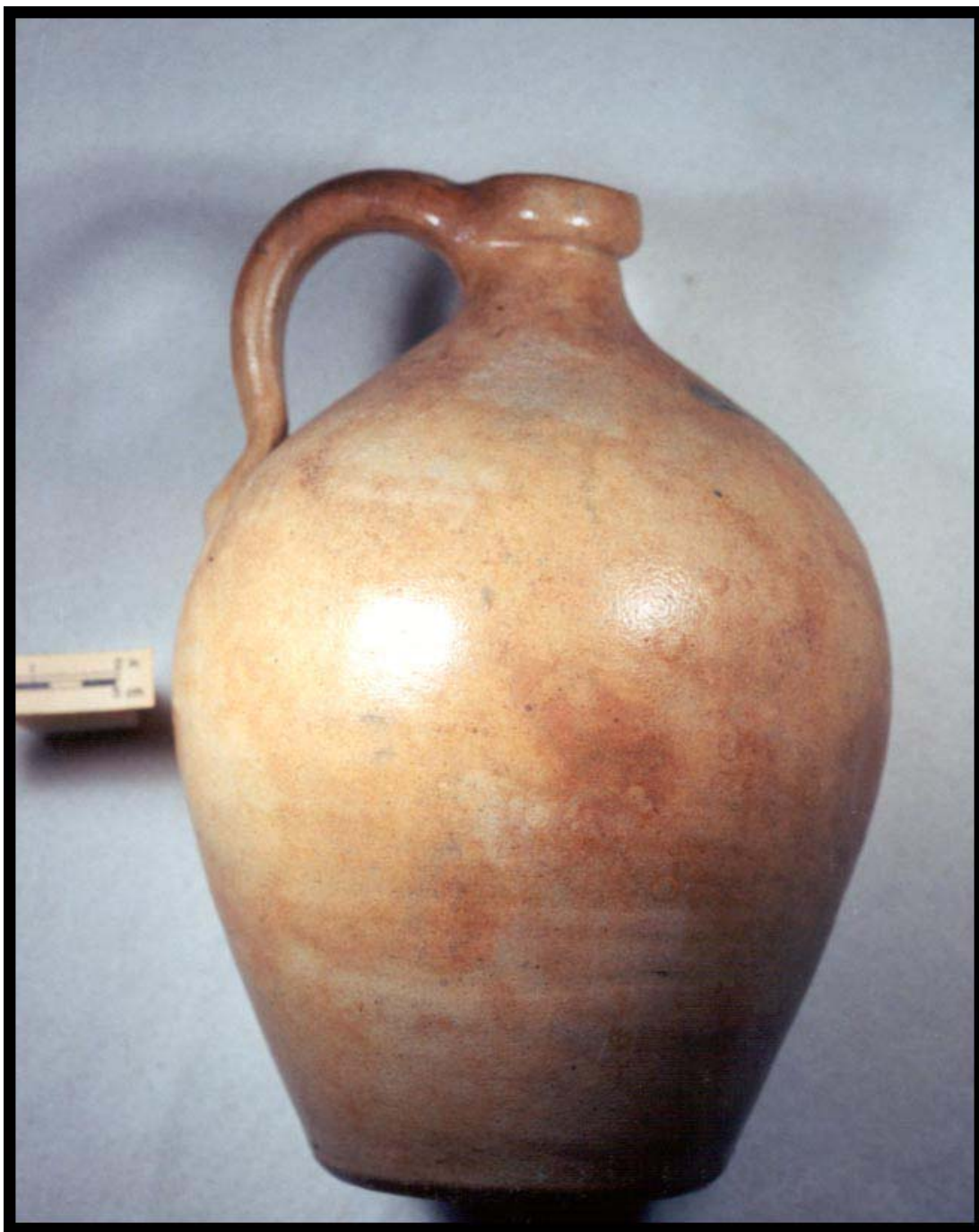

Figure 17. Jug 4. Located in 1970 by Bob Densler from just aft of the mast step under the cargo of wood (photo courtesy of Drew Ruddy).

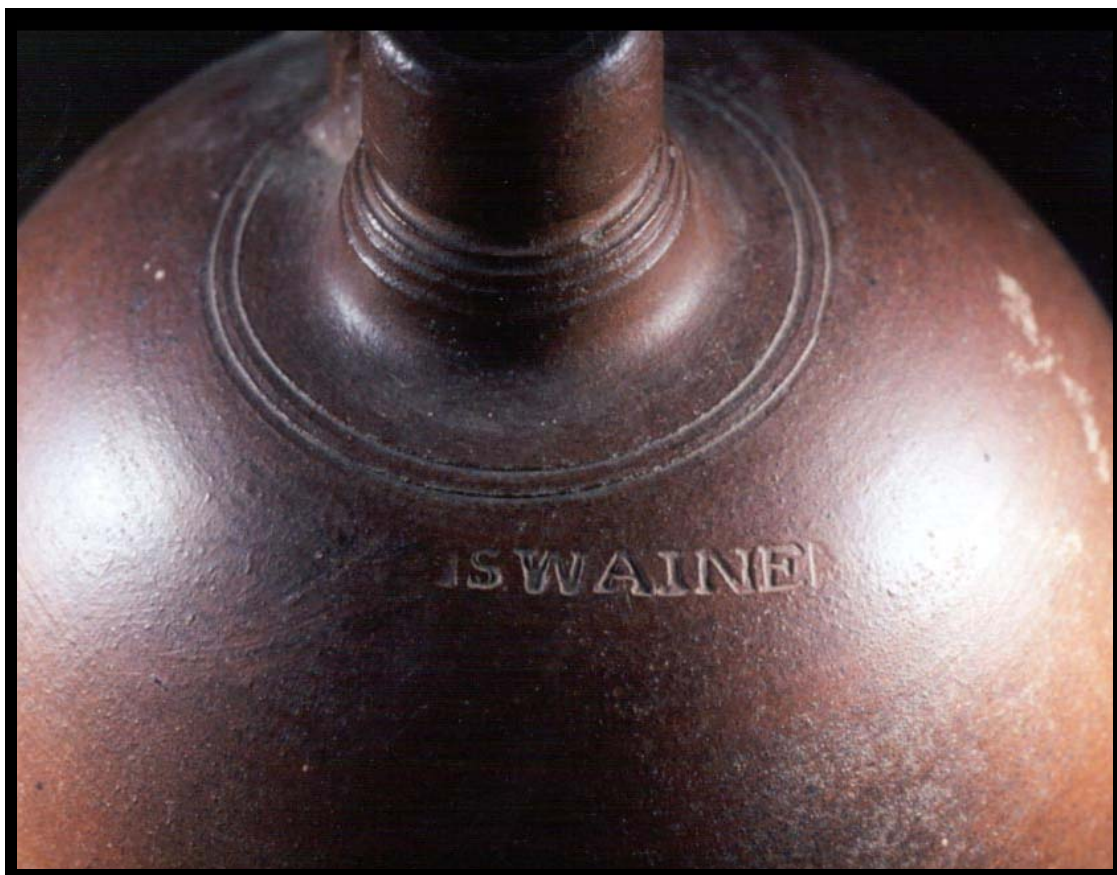

Figure 18. Jug 6. Located in 1970 by Bob Densler from just aft of the mast step under the cargo of wood (photo courtesy of Drew Ruddy).



Figure 19. Jug 8. Located in 1970 by Bob Densler from just aft of the mast step under the cargo of wood (photo courtesy of Drew Ruddy).



Figure 20. Jug 9. Located in 1970 by Bob Densler from just aft of the mast step under the cargo of wood (photo courtesy of Drew Ruddy).



Figure 21. Jug 10. Located in 1970 by Bob Densler from just aft of the mast step under the cargo of wood (photo courtesy of Drew Ruddy).

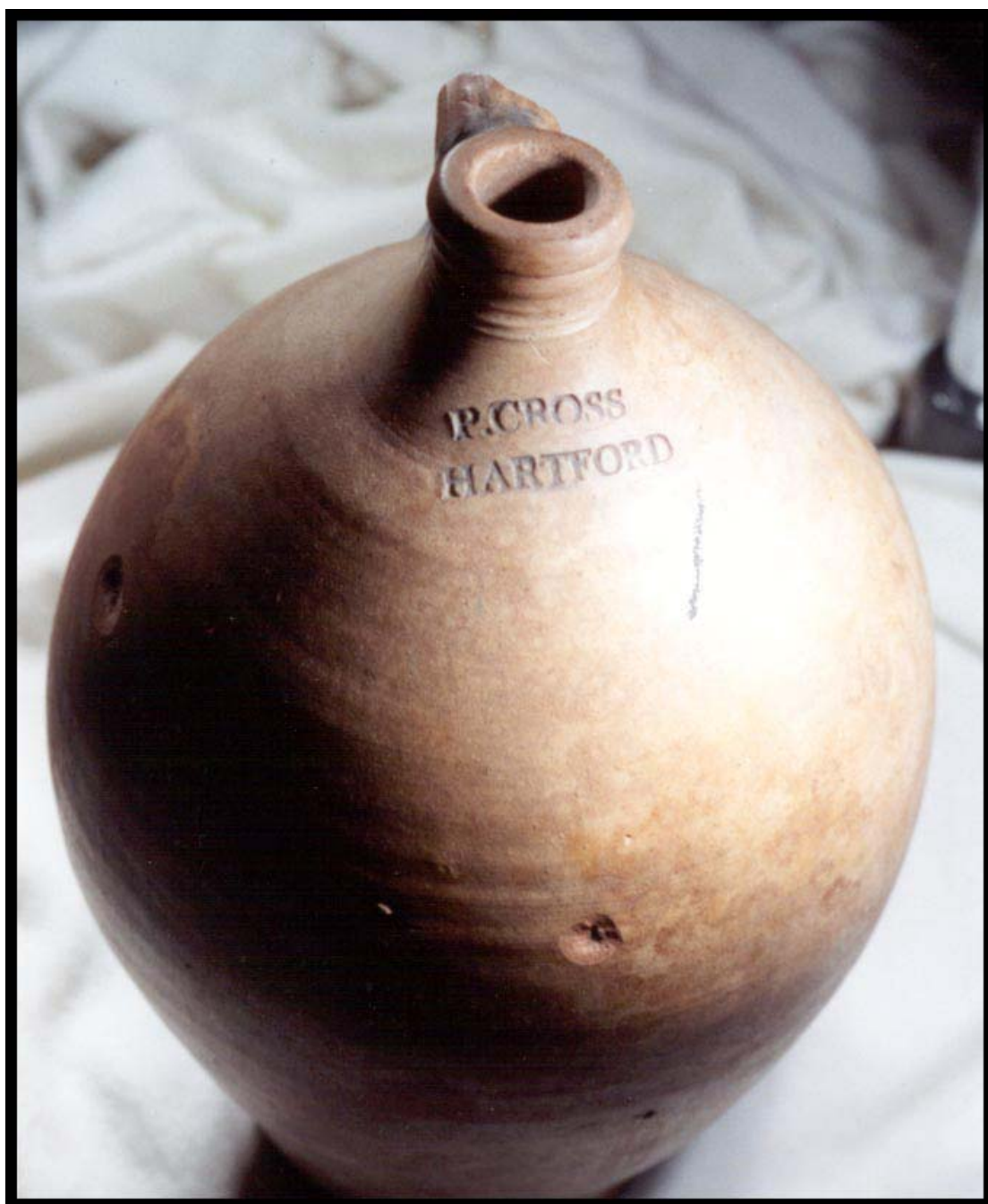

Figure 22. Jug 7. Located in 1970 by Julian Muckenfus from the starboard side of the bow just forward of the mast step (photo courtesy of Drew Ruddy).

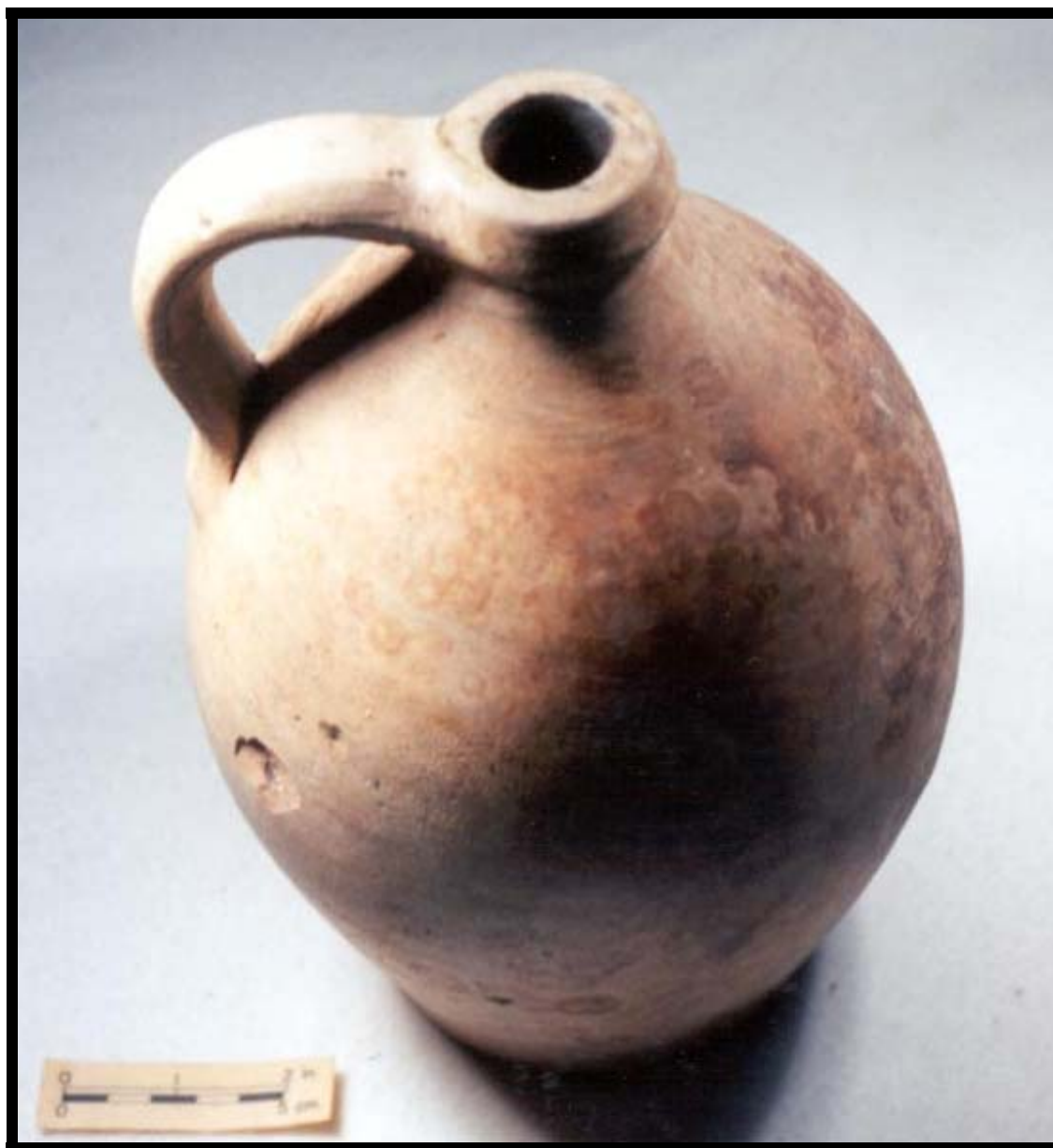

Figure 23. Jug 3. Located in 1971 by Bob Densler among the after portion of the cargo of wood (photo courtesy of Drew Ruddy).



Figure 24. Jug 5. Located in 1971 by Bob Densler from the after portion of the cargo of wood (photo courtesy of Drew Ruddy).

While in Charleston, I visited the Mepkin Abbey to try to examine jug 1, which had been donated to the abbey by Drew Ruddy (Figure 25). Unfortunately the jug could not be located having been packed away while the abbey was undergoing remodeling. I then visited the Charleston Museum where Martha Zierden, curator of historical archaeology, assisted with my study of the Mepkin artifact photos by allowing me to compare them to the museum's stoneware jug collection. Jug 2 was immediately identified as being from the same potter as the museum's HC-765, which was recovered from the Miles Brewton house in Charleston and is now on exhibit in the museum gallery. The Miles Brewton house jug has been reliably dated to the 1770s.

The museum also has two 'SWAINE' jugs in their study collection, HC-301 and HC-302. HC-302 was donated by W.D. Moorer and came from the Marchant's plantation of Charleston, South Carolina. HC-301 was purchased in 1929 from Mrs. S.W. Danner of Orangeburg, South Carolina. The museum had no further information about the origins of either stoneware jug. Drew Ruddy had previously visited the museum and found what he believed was a similarity between jug 4 and the museum's HC-784. However, Zierden and I determined that the two jugs did not closely resemble one another. After comparing their shape, glaze, and overall appearance, we decided all of the Mepkin stoneware jugs could safely be placed in the period of the late 18th through early 19th centuries.

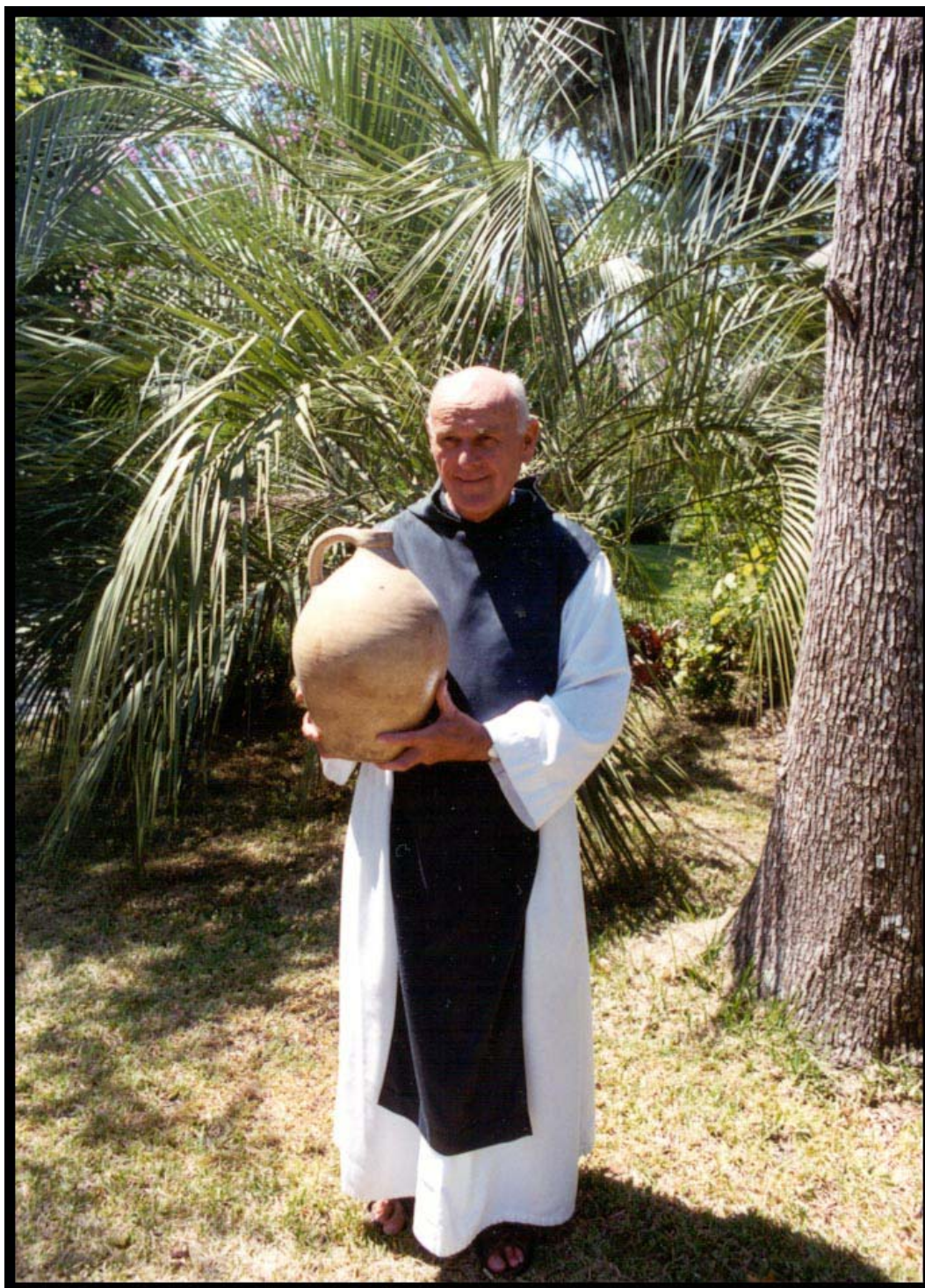

Figure 25. Brother Stephen Petronek Holding Jug 1 (photo courtesy of Drew Ruddy).

The remainder of the artifact research was done using historic reference materials, primarily searching for information on the two maker's marks found on the artifacts. The maker's mark on jug 7 (Figure 22), which reads 'P. CROSS HARTFORD,' refers to Peter Cross of Hartford Connecticut, who was a potter during the years 1805-1818 (Ramsey, 1962: 407). William Ketchum, Jr. in *American Stoneware* writes that: 'One of the earliest kilns was that of Peter Cross, who made salt-glazed stonewares at two different locations on Front Street between 1805 and 1815. His well formed examples, marked P. CROSS/HARTFORD, are rare and valued by collectors' (1991: 60). Although Ramsey and Ketchum differ in the latest date that Mr. Cross was producing stoneware jugs 1818 versus 1815, it is obvious that this is the source for jug 7.

The 'SWAINE' maker's mark (Figure 26) was much more difficult to locate. After utilizing all reference materials available in the Texas A&M University library, I queried ceramics scholars. Dr. William E. Pittman, curator of archaeological collections in the Department of Archaeological Research for the Colonial Williamsburg Foundation identified the jugs as having been made by Thomas and Robert Swaine of Sutton Heath, England between 1825 and 1844 (Oswald *et al.*, 1982: 205). Isaac Slater's commercial directory of 1846 (p.15) listed a 'Swain, Thomas & Robert, 14 College lane and Sutton Heath.' but there was no other information in the other directories that were searched. 1846 is the latest date that the pottery is listed.

Miranda Goodby, senior museum officer (Ceramics), of the Potteries Museum and Art Gallery in the city of Stoke-on-Trent in the United Kingdom forwarded a copy

of an article by Reginald Haggard from the *Northern Ceramic Society Journal*. Haggard states that: ‘In 1825 there were three earthenware manufacturers in Sutton: Nathan Prescott; Fraser and Haddock; and Robert and Thomas Swaine,’ and that ‘The Swaine Brothers Robert and Thomas were making black and brown stoneware in 1825...the Pottery is indicated on the 1843 Tithe Map: the occupier is given as Robert Swaine, and the land owner as Sir Henry Hoghton Bold Bart’ (Haggard, 1984: 14-15). Although the maker’s mark itself is not shown, the article has pictures that show stoneware items similar in form and appearance to the two stoneware ‘SWAINE’ jugs recovered from the Mepkin site. We can be reasonably confident that jugs 6 and 10 were made of English brown stoneware by Robert and Thomas Swaine of Sutton Heath sometime between 1825 and 1846.



Figure 26. Jug 10, Close-up Showing ‘SWAINE’ Maker’s Mark (photo courtesy of Drew Ruddy).

The other stoneware jugs do not have maker's marks or unique characteristics. Dating them can only be done by their general style. Coarse salt glazed stoneware of the utilitarian type and in the ovoid shape, as found on the Mepkin Abbey wreck, were among the early forms. This type of stoneware was formed on a pottery wheel and then fired in a kiln. When the kiln's temperature reached 2000-2200 degrees Fahrenheit, salt was thrown in. The salt would vaporize and react with the silica in the clay, creating a glaze on the stoneware. This was the method of pottery production until machines began producing molded stoneware sometime in the 1890s.

Analysis of the artifacts found on the Mepkin Abbey shipwreck enables us to establish a period of use consistent with the vessel's construction and materials, namely that of the antebellum period. The 'SWAINE' maker's mark found on two of the stoneware jugs gives us a specific date range of 1825-1846 when the Swaine brothers were producing pottery, as the earliest years in which the vessel may have been lost. The Mepkin Abbey vessel is clearly from a much later period than Henry Laurens' *Baker*, which was reported to be badly decayed by 1773. It very likely performed a role similar to that of the *Baker*, that of a multipurpose watercraft workhorse.

DESCRIPTION OF THE MEPKIN ABBEY VESSEL

The following is a description of the Mepkin Abbey Wreck's timber dimensions and assembly techniques. Imperial units of measure are used in the description as this would have been the system used by the shipwrights when they originally built the vessel. The description begins with the keel and follow the general order of frame first construction. The construction drawing (Figure 13) and the final site plan are provided for visual reference (Figure 27).

Described from Archaeological Data

Keel

The keel was originally 41 feet, 3 inches (12.57 m) in length, although the forward tip has eroded, leaving only 41 feet (12.49 m) remaining. It is accessible only at its forward and after end. The forward end of the keel currently has a sided dimension of 6 inches (15.24 cm) and a molded dimension of 2 inches (5.08 cm) where it joins the stem with a flat scarf with two stopwaters. The scarf rises diagonally, aft, a distance of 2 feet, 4.5 inches (72.39 cm) to a molded dimension of 8 inches (20.32 cm) where the stem scarf ends at the nib; here the keel shears straight up another 2 inches (5.08 cm) to a maximum molded dimension of 10 inches (25.4 cm). It has a sided dimension of 10 inches (25.4 cm) at this location, but the top corners are chamfered 2 inches (5.08 cm) in and 2 inches (5.08 cm) down from the rabbet leaving the flat-topped surface of the keel with only a 6 inches (15.24 cm) sided dimension. It is believed that the rabbet extends aft on the keel to a point, about 8 feet, 8 inches (2.64 m) from the end where it is again

- 1 Stem Post
- 2 Mast Step
- 3 Outer Hull Planks
- 4 Stanchion Step
- 5 Keelson

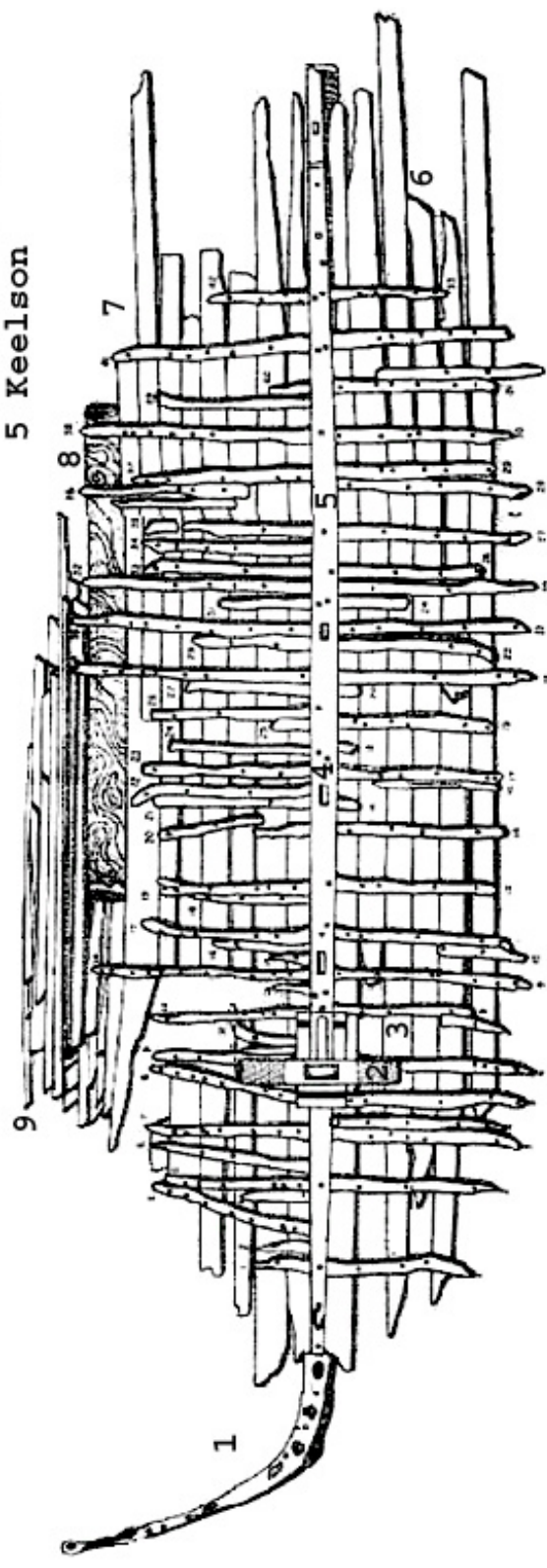

MEPKIN PLANTATION WRECK 38BK48
 SOUTH CAROLINA INSTITUTE OF
 ARCHAEOLOGY AND ANTHROPOLOGY
 OCTOBER, 2000



Lynn Harris 2000

- 6 Loose Stern Planks
- 7 Floor
- 8 Log
- 9 Cargo of Shingles

Figure 27. The Final 2000 Site Plan of the Mepkin Abbey Wreck (drawing by Lynn Harris, courtesy of SCIAA).

visible. This is where the rabbet curves up and into the deadwood. From here, the keel then tapers to 6 inches (15.24 cm) molded and sided at its after end. At the stern, the top of the keel contains a highly eroded mortise, 3.5 inches (8.89 cm) deep, 5 inches long (12.7 cm), and 3 inches wide (7.628 cm), for the stern post tenon. A wood sample was not taken from the keel for identification of the species.

Stem

The stem (Figure 4) is made of live oak according to the results of the 1980 wood analysis (this report is the source for all information on wood types). It is molded 2 inches (5.08 cm) and sided 6 inches (15.24 cm) where it joins the keel with a flat scarf 2 feet, 4.5 inches (72.39 cm) long. The stem then curves the remainder of its 10 feet, 5 inches (3.17 m) length ending at a height (above the base of the keel) of 6 feet, 8 inches (2.03 m). The molded dimension forward of the scarf is 13.5 inches (34.29 cm) and the piece tapers upward to 7 inches (17.78 cm) at its tip. Its sided dimension broadens from 6 inches (15.24 cm) at the scarf to 10 inches (25.4 cm) at the top. The after corners of the stem have a 2 inch (5.08 cm) rabbet for 4 feet, 11 inches (1.5 m), from the stem's aftermost end to where the rabbet merges into the upper apron. A 4 inch (10.16 cm) diameter hole runs laterally through the stem slightly forward of the stem/keel scarf, possibly for a line to haul the vessel out of the water. The stem is attached by eight one inch (2.54 cm) iron bolts to the apron and the keel. Three treenails inserted into the stem join it to the apron. The treenails used on the vessel were 1 inch (2.54 cm) in diameter, the only exception being the .5 inch (1.27 cm) diameter ones used to assemble the rudder. The fastening pattern shown on the stem-keel scarf is an alternating:

bolt/treenail/bolt/treenail pattern. There is a large iron stain on the bottom of the stem where the keel notched into it; what remains of the eroded end of the keel is covered with iron corrosion from the bolt used to fasten them together.

Lower Apron

When combined, the lower and upper aprons have an overall length equaling 15 feet, 1 inch (4.83 m) starting near the upper tip of the stem and terminating, below the keelson, not far forward of the mast step. The lower apron is 7 feet, 8 inches (2.34 m) in length, 6 inches (15.24 cm) sided, and 5 inches (12.7 cm) molded at the butt of the upper and lower timbers. The lower apron then rises aft slightly over its first 13 inches (34.02 cm) to a molded height of 8 inches (20.32 cm). It retains this dimension until it butts into a notch on the bottom of the keelson at the lower apron's after end. The apron itself is notched to fit over two of the floor timbers, frames one and two. Eleven other half frames abut each side of the apron. The fastening pattern on the apron shows that it was nailed and through-bolted with iron bolts to the keelson, floors, keel, and stem. The forward edge of the lower apron is bolted to the stem and the keel; where the keelson starts, on top of the aft end of the lower apron, the pattern (moving aft) shows a nail, a bolt, and then two through-floor bolts all driven through the top of the keelson. At the forward end of the lower apron there is a circular depression 10.5 inches (26.67 cm) in diameter with iron spikes on either side, suggesting that this may be the location of a post, known as a sampson post, that supported the bow sprit.

Upper Apron

Whether due to erosion or vandalism nothing currently remains of the upper

apron although it was present and documented in 1980. According to the drawings, and the remaining fastenings in the stem, it was probably 7 feet, 5 inches (2.26 m) in length, 3 by 5 inches (7.62 by 12.7 cm) molded, and 6 inches (15.24 cm) sided. The fastening pattern, and the remains of the fasteners, in the stem show that the upper apron was attached (starting where it abuts the lower apron) to the stem by a through bolt, two treenails, another through bolt, a spike, three treenails, two spikes (seemingly connected in the manner of a staple but could have been the result of corrosion), and a final treenail. Eleven fasteners were used: two one inch diameter (2.54 cm) through bolts, six 1 inch diameter (2.54 cm) treenails, and three spikes.

Stern Post

The stern post (Figure 5) was fashioned from live oak. It is 7 feet, 9 inches (2.36 m) in length along its after face and 7 feet, 7 inches (2.3 m) along its forward face. The stern post has a 110 degree angle of rake. A 3 inch (7.62 cm) diameter hole runs from side to side through the top of the post. The stern post is molded 12 inches (30.48 cm) at the base and tapers to 9 inches (22.86 cm) at the top. The sided dimension is 6 inches (15.24 cm) throughout. The stern post tenon extends 2.5 inches (6.35 cm) beyond the bottom of the post, but seems to have lost roughly 1 inch (2.54 cm) of its depth, perhaps to erosion, because the mortise in the keel is 3.5 inches (8.89 cm) deep. The tenon, 5 inches (12.7 cm) in length and 1.5 inches (3.81 cm) wide, matches the mortise in length but not in width as the mortise was 3 inches wide. It is not clear whether the tenon was designed this way or if this discrepancy was caused by erosion, or by the conservation treatment that the stern post and rudder assembly underwent. According to Dr. Donny

L. Hamilton (personal communication 2004), post-conservation shrinkage is the most likely explanation, for no functional advantage can be found for the undersized tenon.

When the stern post was recovered, it was placed in a Polyethylene glycol (PEG) conservation treatment along with the stern knee and the rudder assembly in 1980, where it remained until 1990. After treatment nothing remained of the two iron gudgeons other than rust stains left by the 2.5 inch (6.35 cm) wide iron straps used to attach them to the stern post. The straps had been both nailed and bolted in place. The pintles (shown in earlier drawings but missing after conservation) were attached to the rudder assembly by similar iron straps; each strap was long enough to cross two to three sections of the rudder blade and were either nailed or bolted into place.

The stern post was riddled with 26 different fasteners of which there were several types. There were two different sizes of square nails, with heads of .33 inch (8.4 mm) and .25 inch (6.3 mm); three sizes of round iron spikes, with shafts of .5 inch (1.27 cm), 1 inch (2.54 cm), and 1.5 inches (3.81 cm); and there are also two sizes of treenails .5 inch (1.27 cm) in diameter, and 1.5 inches (3.81 cm.) in diameter. Nearly all of the fasteners entered from the front or the rear of the stern post except six of the nails holding the iron straps in place and two treenails. The two treenails were located 4 and 8 inches (10.16 and 20.32 cm) up from the bottom of the stern post. Their purpose has yet to be determined, but the bottom portion of the post also held two additional treenails running fore and aft, and three iron fasteners. These fasteners may have been necessary to secure the tenon (if the tenon actually fit) into a mortise cut into the bottom of the stern post. Of the other fasteners, four treenails and three through bolts were used to

attach the stern knee to the stern post. The two through bolts at the top of the stern post were probably used to attach the post to the transom. One of the drawings from 1980 shows wooden fragments bolted to the forward face of the stern post that supports that theory. Unfortunately no portions of the upper stern exist any longer.

Stern Post Knee

The stern post knee was recovered and conserved in 1980. Its lower arm was 4 feet, 6 inches (1.36 m) long although only 3 feet, 9 inches (1.15 m) remains (the original length of the lower arm was determined by the gap left between the remaining end of the knee and the end of the keelson). The upper arm of the stern post knee measures 3 feet, 2.5 inches (97.79 cm) in length. Both arms are molded anywhere from 5 inches (12.7 cm) to 16 inches (40.64 cm), and are 6 inches (15.24 cm) sided. Planking rabbets were cut into each side of the stern knee; they enter from the deadwood forward and curve up the sides of the knee until they meet the forward corners of the stern post. The knee was attached to the stern post and the deadwood with three iron bolts. There are three transverse treenails in the lower arm of the stern post knee: one on the forward section and two adjacent to where the rabbet enters the knee. These treenails may have been used to secure the half frames that abutted the knee.

Deadwood

The one-piece deadwood is 9 feet, 8 inches (2.95 m) in length, from 9 inches (22.86 cm) to 18 inches (45.72 cm) molded, and between 6 inches (15.24 cm) and 9 inches (22.86 cm) sided. It begins 10 feet, 5.5 inches (3.19 m) from the end of the keel; here it is molded and sided 9 inches (22.86 cm). It expands aft in the molded dimension

and narrows in the sided dimension until it butts against the stern post where the piece is 18 inches (45.72 cm) molded and 6 inches (15.24 cm) sided. It is through-bolted and treenailed to the keel from the stern post knee. The rabbets enter from the keel into the deadwood at its forward lower edges and curve up over the central third of the deadwood's length to where they meet the stern knee. The aftermost floor timber is notched over the deadwood and eight half frames butt against each side of the timber.

Frames

The framing of the Mepkin Abbey shipwreck is unusual in that there is no discernible pattern; the timbers are not consistently spaced along the keel, making the framing difficult to describe. There are 21 floor timbers and 40 known locations where half frames butt-join under the keelson (20 on each side), against the apron or deadwood. Only 28 of the half frames have survived, and over 200 of the individual futtocks, not counting hawse pieces, are missing.

All of the floor timbers are of live oak. They are between 4 and 6 inches (10.16-15.24 cm) molded and between 4 and 5 inches (10.16-12.7 cm) sided. They extend up to the turn of the bilge and were attached with three transverse treenails to the first futtocks. There are nine floors forward of the midship frame and 11 floors aft, for a total of 21 floors. There does not seem to be any consistent pattern associated with their positioning. However, the main cargo area is especially heavily constructed with ten floors located adjacent to, or between, the 8 feet, 2 inches (2.49 m) area where the keelson is notched to fit over the floors. It is unclear if this 'lack of pattern' was original construction or caused by extensive repairs.

Two limber holes have been cut into each floor timber, with one on each side of the keel. They measure 1 inch (2.54 cm) high and 2 inches (5.08 cm) wide. They were roughly chiseled into the floors 5 inches (12.7 cm) away from the keel.

The remaining cant frames, half frames, and first futtocks, also made of live oak, are 6 inches (15.24 cm) molded and between 4 and 5 inches (10.16-12.7 cm) sided. These would have had second futtocks attached in most cases, and each floor would have had first and second futtocks attached to it. All of the known futtocks were laid side by side against the floors and attached with transverse treenails but only 7 first futtocks, and 1 second futtock still exist.

Keelson

The keelson is comprised of two straight timbers of southern yellow pine fitted together with a flat scarf and double-bolted 10 feet, 11 inches (3.32 m) aft of the keelson's forward end. The scarf is directly abaft the single mast step. The forward timber is molded 5 inches (12.7 cm) and sided 6 inches (15.24 cm) at its forwardmost point and increases in dimensions over the first 2 feet, 7 inches (78.74 cm) to 7 inches (17.78 cm) molded and 10 inches (25.4 cm) sided. It continues to increase in molded dimension to 9 inches (22.86 cm) at the keelson scarf. It is a total of 10 feet, 11 inches (3.32 m) in length. The after keelson timber is 10 inches (25.4 cm) sided but is slightly higher, with a molded dimension of 9.5 inches (24.13 cm) at the scarf. This may have been an additional means of bracing the mast step located just forward of the scarf. The scarf is 18 inches (45.72 cm) long and tapers to a nib with a molded dimension of 6 inches (15.24 cm) on the forward timber while the aft timber tapers up to end with a

1 inch (2.54 cm) nib. The after keelson timber is 24 feet, 7 inches (7.51 m) in length and is consistently 10 inches (25.4 cm) sided until it reaches the deadwood, where it begins to taper to its final sided dimension of 6 inches (15.24 cm). The molded dimension of 9.5 inches (24.13 cm) continues to the point where the keelson notches into the deadwood, 5 feet, 5 inches (1.66 m) from the end of the keelson, and then maintains a molded dimension of 5 inches (12.7 cm) until it butt-joins the stern knee.

There are five notches on the after keelson timber's underside, where it increases 1 inch (2.54 cm) in the molded dimension and notches over four frames. The notches begin 4 feet, 9 inches (1.46 m) abaft of the scarf and end 3 feet, 11 inches (1.2 m) before the keelson notch over the deadwood. In the space of 8 feet, 3 inches (2.5 m) these five notches range in length from 7 inches (17.78 cm) to 12 inches (30.48 cm) and fit over the frames, interlocking the keelson and floors. The keelson is attached by 24 bolts that extend through the keelson, most of the floor timbers, and into the keel. Ten iron spikes were also used to secure the keelson to the frames.

Three notches cut into the top of the keelson held stanchions over the main cargo area. The notches begin 11 feet, 6 inches (3.5 m) aft of the keelson's forward end and are evenly spaced 7 feet (2.13 m) apart. The forwardmost notch, located above the keelson scarf, is 5.5 inches (14.04 cm) long, 2.5 inches (6.35 cm) wide, and only .5 inch (1.27 cm) deep. Erosion may have affected the depth of all three notches. The second notch, located amidship, is 5 inches (12.7 cm) long, 2 inches (5.08 cm) wide, and 2 inches (5.08 cm) deep, while the aftermost notch is 5.5 inches (14.04 cm) long, 3 inches (7.62 cm) wide, and 1.5 inches (3.81 cm) deep. Nothing remains of the stanchions

themselves; they may have been of the same dimensions as the tenons or they may have been of heavier construction.

Mast Step

The mast step, located slightly less than one third of the vessel's overall length abaft the stem, was carved from a single large piece of live oak. It is 5 feet, 7 inches (1.7 m) long, molded 14 inches (35.56 cm), and sided 10 inches (25.4 cm). It fitted laterally and straddles the keelson and two sister keelsons. This kind of transverse arrangement is called a 'saddle' mast step. The step, or mortise, on top of the timber was drilled with four auger holes and then chiseled out to be an opening 7 inches (17.78 cm) long, 12 inches (30.48 cm) wide, and 4 inches (10.16 cm) deep. There is a shallow auger hole on the port side of the mortise where the shipwright started to cut the mortise in the wrong place. There are no fastenings of any kind attached to the mast step. It was held in place by its notch over the keelson and sister keelsons as well as by two curved tongues of wood placed fore and aft against it.

The tongues of wood that braced the mast step were still attached to the keelson in 1980, but by 2000 only the after tongue remained. The after tongue is 1 foot, 6.5 inches (46.99 cm) in length, between 5 and 7 inches (12.7-17.78 cm) molded, and 4 inches (10.16 cm) sided. The fore tongue was 14 inches (35.56 cm) in length, 5 inches (12.7 cm) molded, and 4 inches (10.16 cm) sided. Both arch up from the keelson to brace the step and, according to the 1980 field notes, were secured to the keelson with five iron bolts in each tongue. They were not attached to the step in any way but were part of an overall assembly that stepped and supported the single mast with the

assistance of the sister keelsons.

Two sister keelsons are attached on either side of the keelson with iron bands. They start 7 feet, 6 inches (2.28 m) abaft the keelson's forward end and are 3 feet, 4.5 inches (1.03 m) in length, 6 inches (15.24 cm) molded, and 5 inches (12.7 cm) sided. The remaining iron bands are 2 inches (5.08 cm) wide and are attached 3 inches (7.62 cm) from either end of each sister keelson timber. The sister keelsons' tops are flush with the keelson, doubling the structural support for the saddle mast step located above them.

This mast step is constructed similarly to that of the British Army sloop *Boscawen* (1759), which was built for service on Lake Champlain during the French and Indian War. *Boscawen* was abandoned after the war near Fort Ticonderoga on Lake Champlain but was relocated and excavated in the early 1980s (Crisman 1988: 143-147). The 115 ton, 16-gun *Boscawen* was approximately 75 feet (22.86 m) in length and 25 feet (7.6 m) in beam, much larger than the Mepkin Abbey shipwreck.

Hull Planking

Made of southern yellow pine, the hull planking was between 10 and 18 inches (25.4-45.72 cm) wide and approximately .75 to 1 inch (1.99 to 2.54 cm) thick. The hull was carvel planked. Ten strakes remained on the starboard side and seven on the port side in 1980, but only nine and six, respectively, were present in 2000. There were eight strakes of planking on each side of the bottom to the turn of the bilge. The remaining strakes were eroded and damaged at their ends, but six of them had lengths that extended as much as 12 inches (30.48 cm) beyond the end of the keel. The garboard strake is

slightly thicker than the rest of the planking, being 10 inches (25.4 cm) wide and 1.5 inches (3.81 cm) thick. A preliminary count of plank fastenings on exposed frame surfaces revealed 227 treenails and only 30 iron fastenings, suggesting that the planks were principally treenail fastened.

Ceiling Planking

Some of the ceiling planking still existed in 1980, but none existed by 2000. Fastenings in the tops of the frames indicate where the ceiling was attached; approximately 90% of these were treenails and only 10% metal fasteners. According to the 1980 data, the ceiling was 1 inch (2.54 cm) thick and 10 inches (25.4 cm) wide. It is not clear how far the ceiling extended up the sides of the hull.

Rudder

The heavily constructed rudder blade (Figure 5) was 4 feet, 1.5 inches (1.26 m) wide at the bottom and 1 foot, 5 inches (43.18 cm) wide at the top. It was 6 inches (15.24 cm) thick and had an overall height of 5 feet, 4 inches (1.63 m). It was made of five pieces of wood edge-fastened together with .5 inch (1.27 cm) diameter treenails. It was also held together with four iron straps, which were between 3 and 4 inches (7.62-10.16 cm) wide, two of which were pintle straps. The pintle straps were nailed into the wood with five square-headed iron nails per side. Two sizes of nails seem to predominate: .25 inch (6.35 mm) and .33 inch (8.38 mm). There is a 1 inch (1.27 cm) diameter hole centrally located 2 inches (5.08 cm) from the lower edge of the rudder blade. Ralph Wilbanks suggested the hole 'was probably for a keep for the rudder to protect it from being lost if it became dislodged' (156). Another suggestion, because of

the low position of the hole, is that it was used to support the rudder while it was being mounted in the water.

The rudder stock was constructed from two pieces of wood. These timbers are highly eroded but were connected with .4 inch (1.02 cm) square-headed iron bolts or spikes, and treenails. Iron-stained notches show where the two iron straps were used to hold the rudder blade and stock together. There are also iron stains remaining from the pintle straps. The rudder, rudder stock, stern knee, and stern post were all recovered in 1980 and conserved by the SCIAA team. Another piece, also labeled as rudder stock, was recovered as well but was not with the rest of the assemblage in 2000. It could possibly have fit between the two remaining pieces of stock, together making up the rudder post and securing the blade to the stern post. The resulting post would probably have been 8 feet, 3 inches (2.52 m) in height, 1 inch (2.54 cm) thick, and 6 inches (15.24 cm) wide. The 1980 report also mentions a small piece of wood concreted to the rudder that could have been a rudder stop, but it no longer exists; a rudder stop is used to keep the rudder from floating out of the gudgeons.

Reconstruction of Missing Elements from Comparative Sources

The preceding section describes the wreck, both as surveyed in 1980, and as it was 20 years later in 2000. Only the bottom of the hull remains, except for the stem and stern. The surviving elements show the vessel framework; these remaining elements were primarily made of live oak, a long lasting wood, and were fastened with treenails, bolts, and spikes. The vessel may have been heavily repaired.

Since the upper part of the vessel is absent, and unlikely to ever be reconstructed with certainty, the missing elements were constructed (Figure 13) based on clues obtained from the surviving lower hull and from evidence obtained from other archaeological examples, including the Brown's Ferry vessel, the Malcolm boat and the Clydesdale Plantation sloop (details of these wrecks are provided in the following chapter). These three shipwrecks were found in the coastal regions of South Carolina and Georgia and have been dated to the 18th or early 19th centuries. Referenced also were similar types of watercraft discussed by Howard I. Chapelle in his books *American Small Sailing Craft: Their Design, Development, and Construction* (1951); *American Sailing Craft* (1975); and *The History of American Sailing Ships* (1935). It must be emphasized that the reconstructions of missing elements are conjectural, but they nevertheless give us a sense of how the original vessel might have been built and what it may have looked like.

Transom

The transom stern sits directly on top of the stern post rabbet. Evidence for its construction was suggested by the length of the remaining hull strakes. These planks were longer than the keel. The transom stern was also customary in South Carolina during the 18th and 19th centuries; the Brown's Ferry vessel, the Malcolm boat, and the Clydesdale Plantation vessel all had transom sterns (Amer & Hocker, 1995: 295-303).

Wale and Gunwale

The two uppermost strakes on the hull, the wale and the gunwale, are used for strengthening and stiffening the outer hull. These timbers are 2 inches (5.08 cm) thick,

approximately twice as thick as the hull planking, and 11 inches (27.94 cm) wide. There is a 2 inch (5.08 cm) gap between them to act as a scupper for drawing water from the deck.

Shelf Clamp

Modeled after the shelf clamp used on the Malcolm boat (Figure 28), of which approximately half survived, the shelf clamp on the reconstructed Mepkin Abbey vessel has 1 inch deep (2.54 cm) notches along its upper edge to support the deck beams (Amer, 1993: 53). It is 11 inches (27.94 cm) molded and 3 inches (7.62 cm) sided

Deck Beams

The report on the 1980 fieldwork mentions the finding of two timbers that could have been deck beams, because they had notches that corresponded to the stanchion notches on the upper surface of the keelson. These two timbers are no longer on the wreck. The reconstructed deck beams, based the Malcolm boat's one surviving beam, are molded 5 inches (12.7 cm) and sided 6 inches (15.24 cm). They are cambered so water will run to the sides of the vessel and out the scuppers. Three deck beams can be confidently placed directly over the keelson stanchion slots in the main cargo area of the hold. The rest have been spaced at even intervals and situated to best support the deck in a manner consistent with the other construction features of the vessel.

Lodging Knees

Knees are only mentioned once in the 1981 preliminary report on the Mepkin Abbey wreck, and other than the fact that two knees were found and seemed to be related to a deck, there is no further documentation (Wilbanks, 1981: 155). The knees

used in the reconstruction are modeled after those used on the Malcolm boat (Figure 28), the knees are similar but slightly more heavily constructed as is the remainder of the Mepkin Abbey vessel (Amer, 1993: 54). They are 2 feet, 4 inches (71.12 cm) in length, 5 inches (12.7 cm) molded, and 5 inches (12.7 cm) sided. Thirteen horizontal lodging knees have been added per side to support the deck beams.

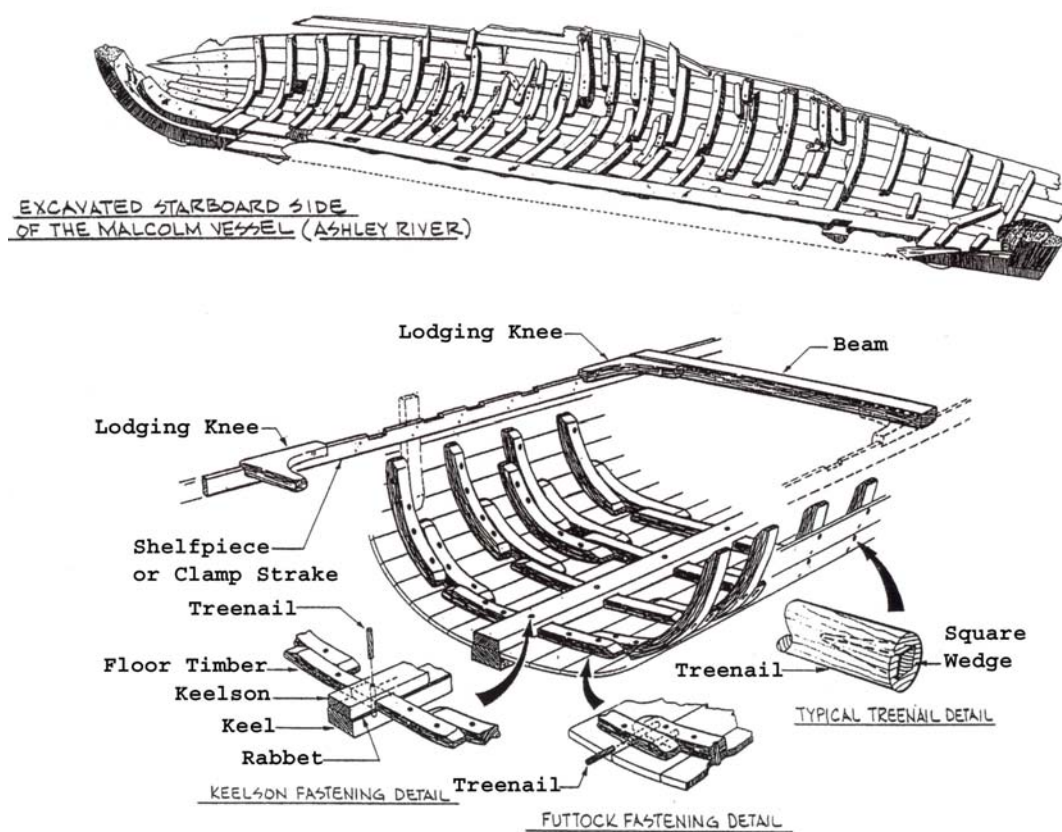

Figure 28. Excavated Starboard Side of the Malcolm Boat (drawing by William R. Judd courtesy of SCIAA).

Carlings

The carlings, fore-and-aft timbers used to stiffen the deck beams and support the ledges, are molded 6.5 inches (16.51 cm) and sided 4.5 inches (11.43 cm).

Breast Hooks

Two breast hooks, horizontal knees attached to the stem and side, have been placed in the bow to strengthen this area.

Hawse Pieces

Two hawse pieces, fore-and-aft framing timbers, were added to further strengthen the bow.

Cap Rail

The cap rails, used for covering the frame tops and the gunwale, are 2 inches (5.08 cm) thick and 9.5 inches (24.13 cm) wide.

Deck Planking

Although no deck planking survived, the reconstructed planking was based on similar types of watercraft as discussed by Howard I. Chapelle (1951, 1975, 1935). They most likely were 1 inch (2.54 cm) thick and 6 inches (15.24 cm) wide.

Hatches

The ship's deck has 3 hatches. The largest hatch, measuring 10 feet, 6 inches (3.2 m) long and 7 feet, 4 inches (2.23 m) wide, is placed directly over the main cargo area. Its size was determined by the stanchions supporting the deck beams and the deck space needed on either side. The last load the vessel carried consisted of long planks, and a large hatch opening would have been necessary to load and unload such cargo.

Two other companionways were added, one with sides of 3 feet, 4 inches (1.03 m) just forward of the mast to allow access to the bow, and one with sides of 3 feet (91.44 cm) between the stern and the cargo area to allow access to the after hull.

Coaming

Each hatch is surrounded with coaming which is 5 inches (12.7 cm) molded and 3.5 inches (8.89 cm) sided.

Ship's Pump

A simple pump was added just abaft and to the port side of the mast. Pumps were placed where bilge water collected to ease its removal.

Log Windlass

A log windlass, similar to the one Richard Steffy (1994: 167) reconstructed on his model (Figure 29) of the Brown's Ferry vessel, was placed on top of the keelson and is braced at its forward edge by a deck beam. The Mepkin Abbey vessel was large enough to have required the use of a log windlass to haul anchors and hawsers.

Bitt Post

A bitt post was attached to the caprail near the bow for securing lines and to support the log windlass.

Tiller Arm

A curved tiller arm, customary for smaller vessels at this time, was installed to aid in operating the rudder; wheels were usually found only on larger ships.

Sampson Post

Like the Malcolm boat (Amer 1993: 61) and the Clydesdale Plantation vessel

(Hocker 1992: 12-16), the Mepkin Abbey vessel had only one mast and presumably a bow sprit. A sampson post was reconstructed to support the heel of the bow sprit. It measures 5 feet, 9 inches (1.75 m) in height, 4 inches (10.16 cm) molded, and 6 inches (15.24 cm) sided. The post has been positioned just ahead of the keelson and butts against it. It sits atop the apron just aft of the scarf between the lower and upper aprons, where there is evidence of its existence in the form of a circular depression with iron stains from fasteners. A deck beam provides additional support directly behind the post. The post has a 4 inch by 4 inch (10.16 cm by 10.16 cm) mortise located between 16 and 20 inches (40.64-50.8 cm) from its top to accept the tenon on the heel of the bow sprit.

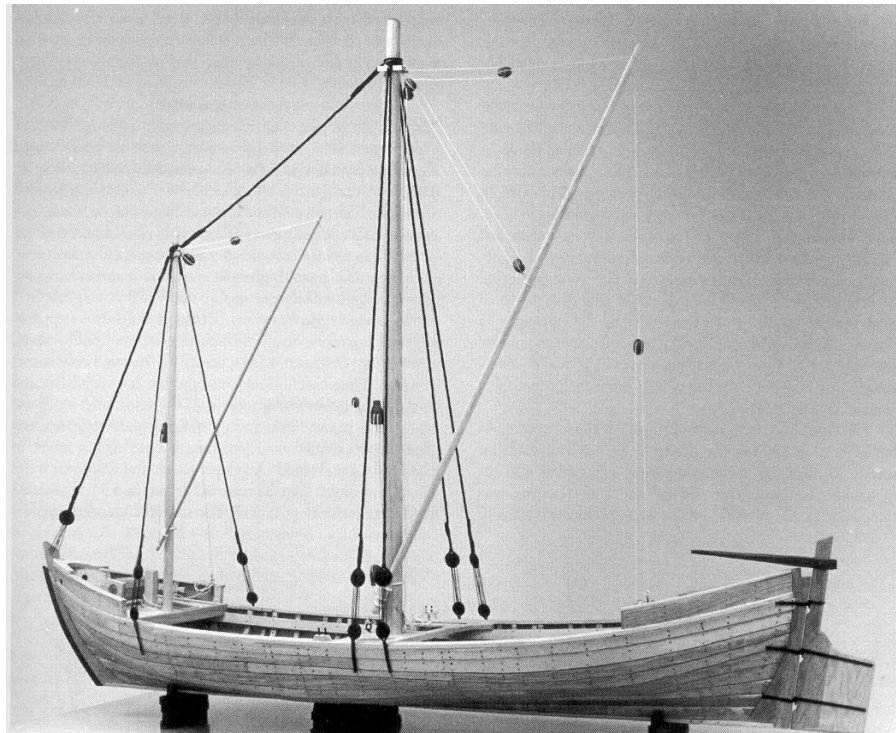

Figure 29. The Brown's Ferry Research Model (model and photo by J. Richard Steffy). The photo of this early model, made without the transom, shows a log windlass on the forward deck.

Bow Sprit

The bow sprit is 6 inches (15.24 cm) in diameter with a 4 inch (10.16 cm) tenon on the end to fit into the sampson post. The bow sprit is canted in the sampson post and rests atop the stem and upper apron. It is further supported on the sides by fairleads and probably would have been secured to the top of the stem by an iron strap or perhaps some kind of gammoning.

Mast

Based on the size of the mortise in the mast step, the mast has been reconstructed with a 10 inch (25.4 cm) diameter base and tapers to 9.5 inches (24.13 cm) at the top. As nothing remains of the original mast there is no way to know its precise dimensions.

Chainplates

Three chainplates with deadeyes were placed on the caprail on each side of the hull to attach the shrouds. The forward most one is adjacent to the mast, and the other two are 20 inches (50.8 cm) and 40 inches (1.02 m) aft of the first.

COMPARATIVE ANALYSIS

Three previously named vessels, excavated and studied in the coastal regions of South Carolina and Georgia, are of similar size and age to the Mepkin Abbey shipwreck. They are: the Brown's Ferry vessel, the Clydesdale Plantation sloop, and the Malcolm boat. This chapter will examine the three wrecks and compare them, including the locations when discovered, excavation dates, determined or believed dates of usage, hull dimensions, scantlings, construction methods, materials, propulsion, purpose, and areas of use. The goals of this analysis are to determine how these vessels compare to the Mepkin Abbey shipwreck.

The Brown's Ferry Vessel

In 1976 a shipwreck was recovered at Brown's Ferry on the Black River in Georgetown County, South Carolina (Figure 30). The fully laden vessel was carrying 25 tons (25,401.2 kg) of bricks when it sank and has been dated to the middle of the 18th century based on a limited number of recovered artifacts. With a length of 50 feet, 3 inches (15.32 m) and a beam of 14 feet, 2 inches (4.32 m), the ship had a length:beam ratio of 3.6:1; the maximum depth amidships was 4 feet (1.22 m) (Figure 31) (Amer and Hocker, 1995: 297). The vessel did not have a keel, but was fitted with a heavy pine keel plank (Figure 32) and was built in the bottom-based construction tradition in which the bottom of the vessel is the main structural component. The remaining timbers were fashioned from local woods as well: the frames and end posts were made of live oak, the planking of southern yellow pine, and the keelson of cypress. Treenails, iron nails, and

iron bolts were used for fasteners. The vessel had a small transom stern and carved into the keelson were two mast steps. In addition to sail, the ship was propelled by the oars and punting poles found with the wreck. The vessel has been described as the ‘short-haul truck of her time’ (Steffy 1988: 124). It was intended for river use, and its heavy flat bottom would have enabled it to beach on the river banks to load and unload cargo. Such a vessel would also have been capable of short journeys in coastal waters and could even have been used to make trips to Charleston, approximately 75 miles (120.7 km) away from where the wreck was discovered.



Figure 30. Recovery of the Brown's Ferry Vessel (photo: Gordon Brown; courtesy of SCIAA).

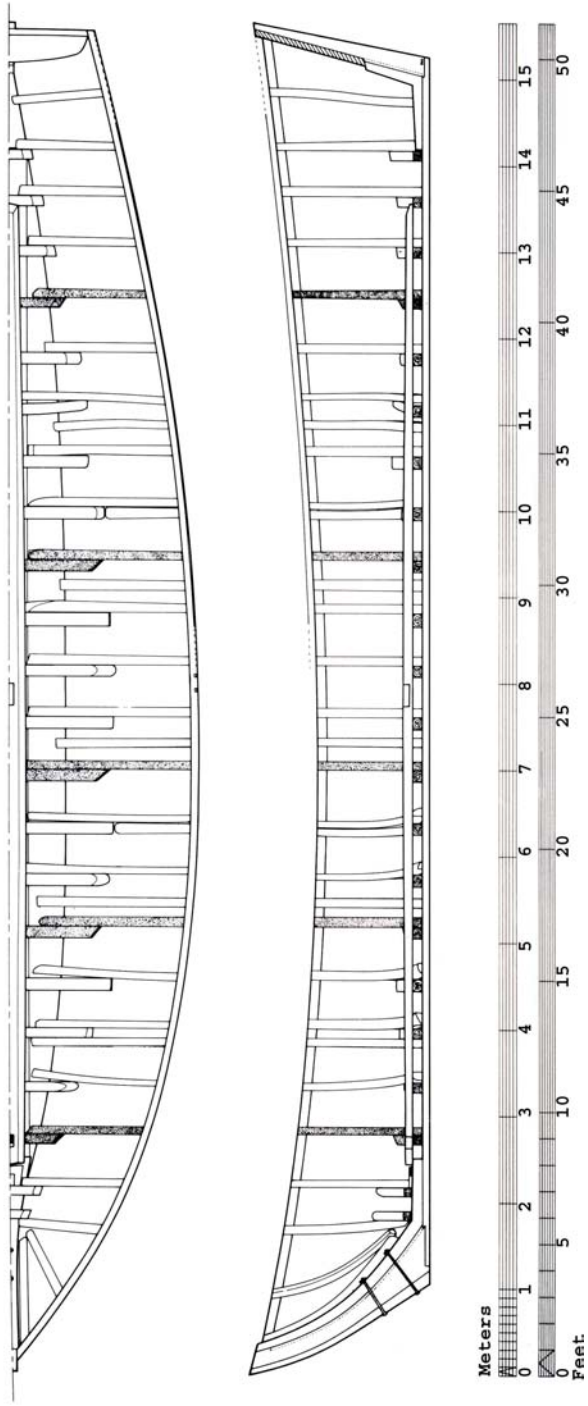

Figure 31. Construction Plan and Interior Profile of the Brown's Ferry Vessel (reconstructed and drawn by Frederick M. Hocker; courtesy of SCIAA).

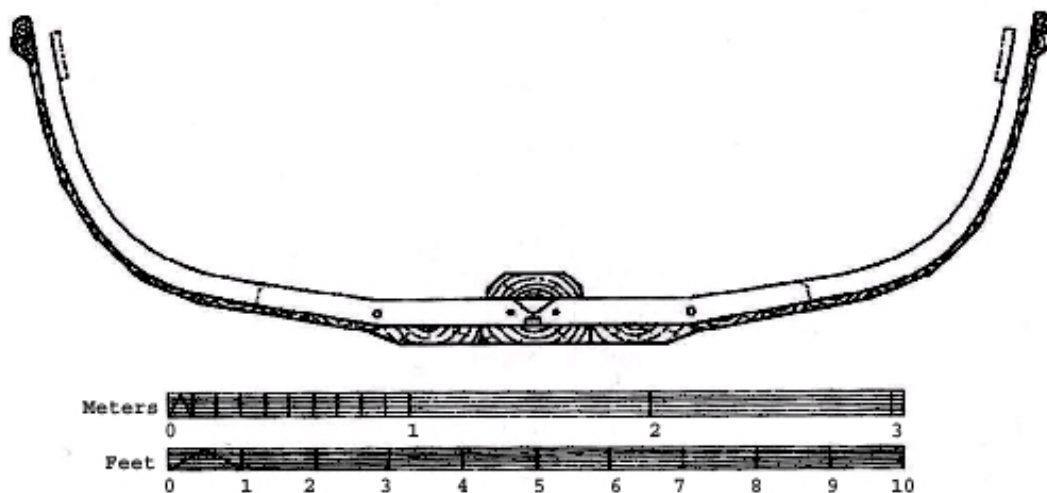

Figure 32. Section drawing of the Brown's Ferry Vessel (reconstructed and drawn by Frederick M. Hocker; courtesy of SCIAA).

The Clydesdale Plantation sloop

The Clydesdale Plantation sloop was excavated in the Back River (a secondary channel of the Savannah River not far from Savannah, Georgia) in 1992 (Figure 33).

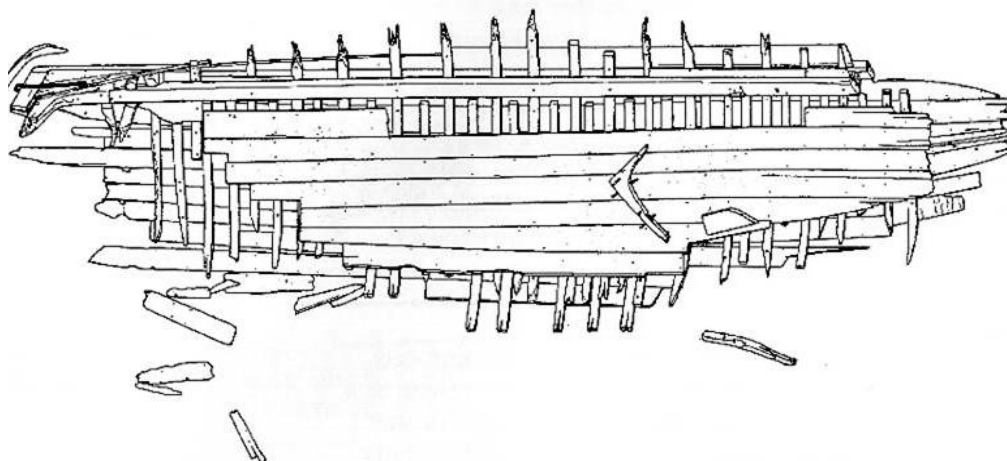

Figure 33. Remains of the Clydesdale Plantation Sloop (drawn by Frederick M. Hocker; Amer & Hocker 1995: 299).

‘The vessel is not easily dated, as it had been stripped and deliberately buried to stabilize a rice bank (levee), but it was probably buried sometime between 1780 and 1820’ (Amer and Hocker 1995: 299). The upper stem assembly and much of the port side were missing, but the starboard side was preserved nearly to the deck level amidships.

The remains were sufficiently preserved to get an accurate idea of the vessel’s construction and use. With an original length of 43 feet, 9 inches (13.34 m) and a beam of 15 feet, 5 inches (4.7 m), the ship has a length:beam ratio of 2.84:1. The ship would have had a maximum depth of 6 feet, 3 inches (1.9 m) amidships and would have held between 20 and 25 tons (20,320.9-25,401.2 kg) of cargo. Its construction began with a deep and heavy keel of yellow pine (Figure 34). The stern post, stem, apron, frames, and futtocks were all made of live oak. Like the keel, the keelson, planking, and ceiling planking were made of pine (Amer and Hocker 1995: 299).

Fasteners used included iron nails, spikes and bolts, and wooden treenails. The shipwreck’s principle excavator, Fred Hocker, found

...the most remarkable feature of construction [to be] in the frames. Unlike most other Western vessels of the post-medieval period, in which each floor timber (the central member of the frame) is associated with two or more futtocks fastened to or at least set against the floor timber, the Clydesdale vessel has frames almost identical to those of an ancient Greek or Roman ship. The live oak frame components are separate and evenly spaced, so that floor timbers fastened to the keel alternate with half-frames that run from the garboard to the deck. Futtocks in line with the floor timbers continue up to the deck as well. The bulwarks are supported by short, separate top timbers set between the half-frames and futtocks. None of these timbers is attached to any other. The only other vessel in North America framed in a similar manner is the *Boscawen*, a Royal Navy sloop built on Lake Champlain in 1759, although the naval sloop includes several complete ‘made’ frames used to define the shape of the hull. (Hocker 1992: 16)

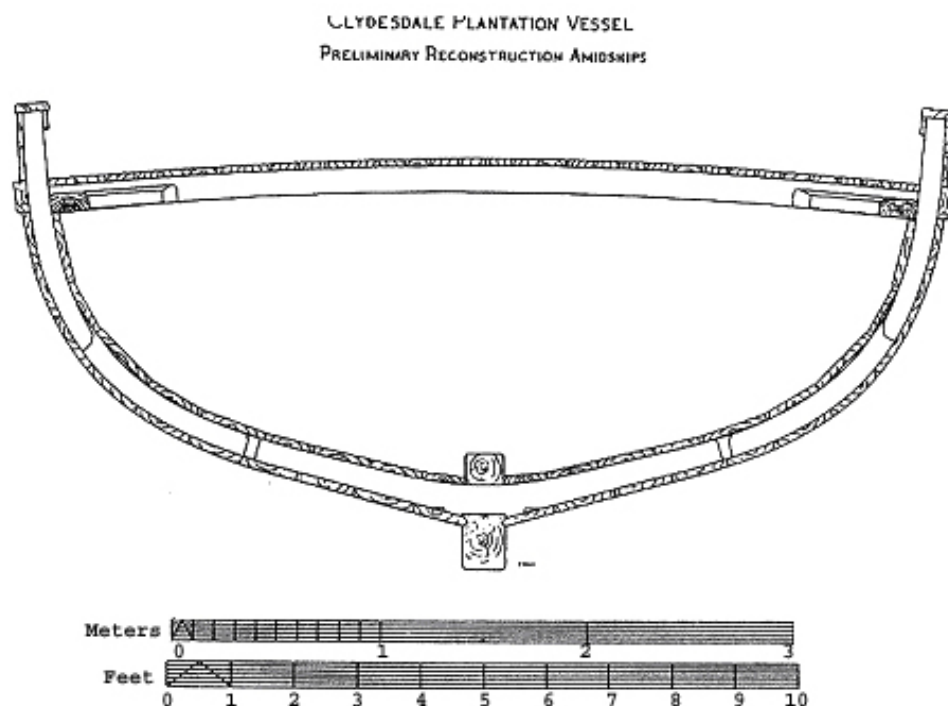

Figure 34. Section drawing of the Clydesdale Plantation Sloop (drawn by Frederick M. Hocker; Hocker 1992: 17).

There was a transom stern (Figure 35). A single mast, set forward of amidships, likely supported a sloop rig (sloop rigs were common for ships of this size in 18th and 19th centuries in the Carolinas). Amer and Hocker (1995: 30) believe that the Clydesdale Plantation sloop was ‘a fast, powerful sailing vessel with relatively little cargo capacity.’ While the hold was constructed tightly enough to have carried rice (tight in this case means waterproof), it is doubtful this was its primary purpose, as the vessel would have been better suited to the work of a pilot vessel, taking passengers between Charleston and Savannah, or even to trade as far away as the West Indies or Bermuda. It would have handled well in deep water with its heavy keel, sharp entrance,

noticeable deadrise, and long fine run (Amer and Hocker 1995: 299), yet it was small enough to travel the coastal rivers around Savannah.

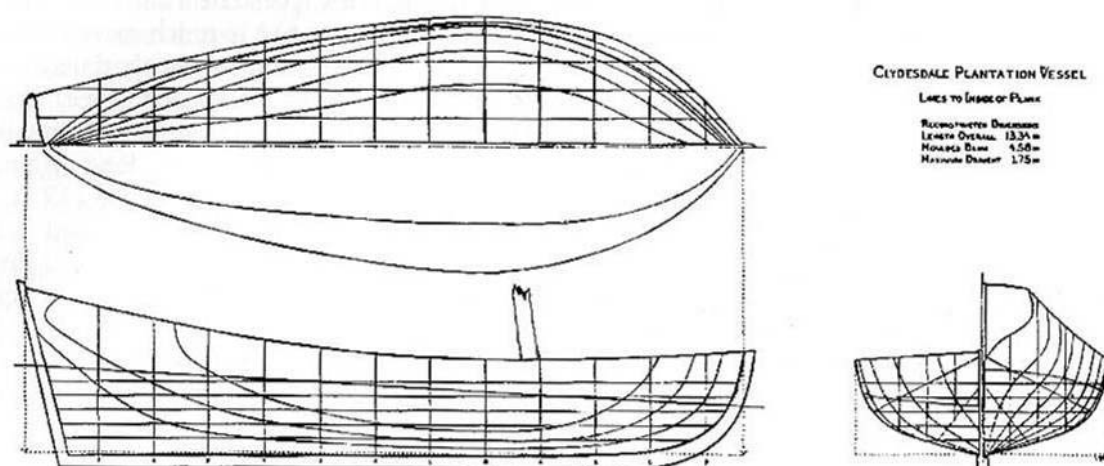

Figure 35. Lines of the Clydesdale Plantation Sloop (drawn by Frederick M. Hocker; Hocker 1992: 16). The drawing shows the vessels transom stern and single mast.

The Malcolm boat

The Malcolm boat was excavated in the Ashley River outside of Charleston, South Carolina in 1992 (Figure 28). ‘All of the artifacts recovered can be dated to a period roughly encompassing the last quarter of the 18th century and the first quarter of the 19th century’ (Amer, 1993: 56). The boat is believed to have had a lengthy career prior to being stripped and abandoned on the bank of the river. With a length of 41 feet, 10 inches (12.75 m) and a beam of 11 feet, 9 inches (3.58 m), it had a 3.56:1 length:beam ratio. The depth of hold was 4 feet, 11 inches (1.5 m) and the vessel would have had a displacement of about 24 tons (24,385.1 kg).

Its construction employed local woods: the keel was of southern yellow pine, as were the seemingly reused ceiling planking and some of the hull planking. The garboard planks were made of cypress, the end posts were of live oak, and the frames and futtocks of both live and white oak. Fastenings included iron bolts and nails, as well as wooden trenails. The pine keelson was of substantial size and was notched over and fastened to each frame.

Two rectangular mast steps were carved into the keelson: one located above the midship frame (approximately one third of the vessel's length abaft the stem) and the other step, which was partially plugged, was set further aft, yet still in the forward half of the ship (Figure 36). Amer and Hocker describe the boat as being 'designed for strength and with the ability to carry heavy loads' (1995: 300). They also felt that 'the transom stern would have enhanced the vessel's cargo-carrying capacity and seaworthiness for offshore voyages' (Figure 37). The Malcolm boat would have been suited to both offshore and riverine usage, and the reconstruction drawings by William Judd show a fine craft that was well made, functional, and aesthetically pleasing (Figure 38).



Figure 36. Malcolm Boat's Mast Steps (photo courtesy of SCIAA).



Figure 37. Malcolm Boat's Surviving Transom Planking (nail holes are highlighted by white pins but the scale shown at the bottom of the photo is unreadable in the originally published photograph). One of the three planks was located wedged tightly against the stern post, the other two planks were excavated aft of the stern (Amer and Hocker 1995: 48) (photo courtesy of SCIAA).

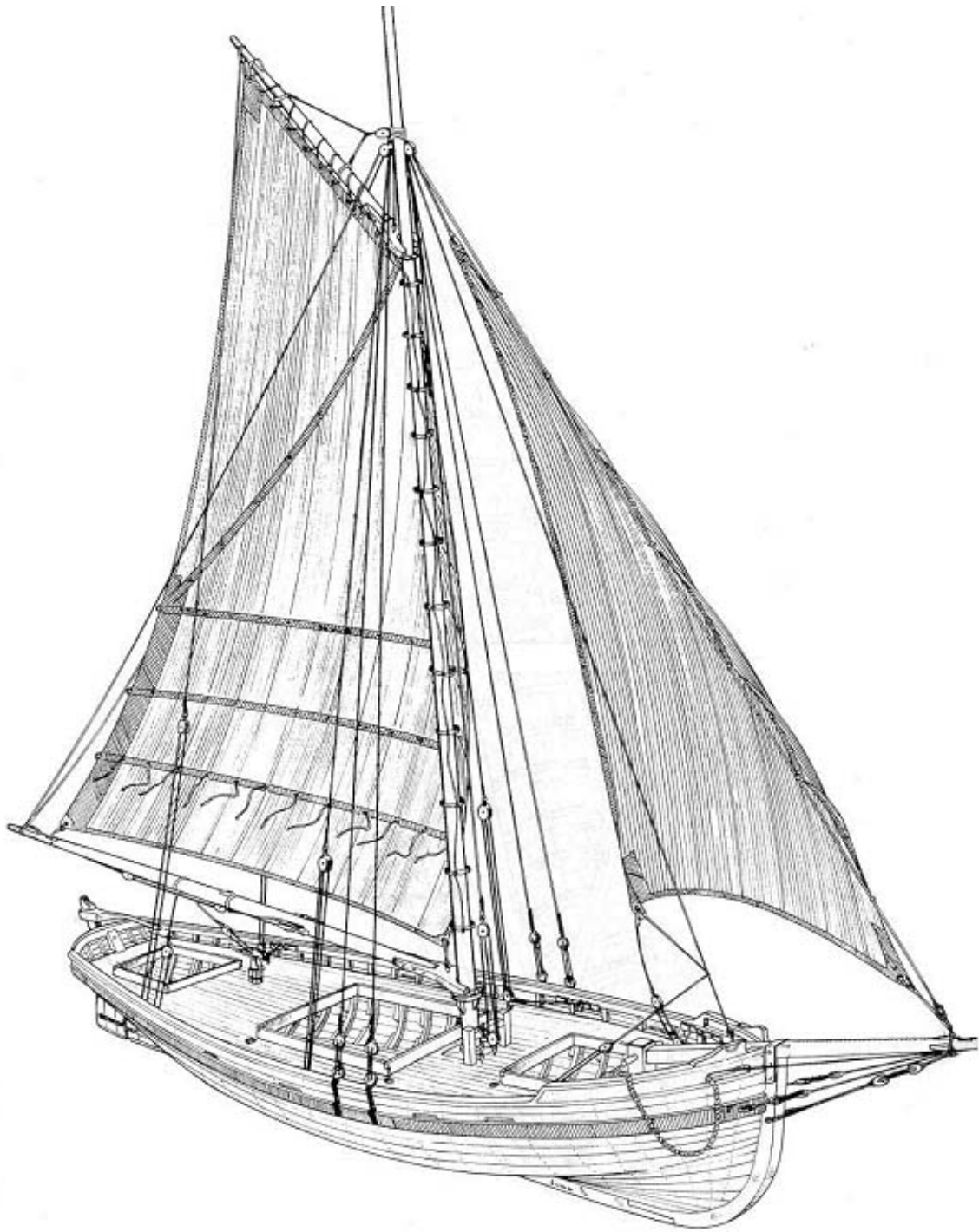

Figure 38. Reconstruction of the Malcolm Boat with a Gaff Rig (drawing by William R. Judd, courtesy of SCIAA).

Analysis

Location: The Mepkin Abbey shipwreck and the Brown's Ferry vessel were both loaded with cargo when found. Why they sank is unclear, but their sinking more than likely was accidental, unlike the circumstances surrounding the Clydesdale Plantation sloop and the Malcolm boat. The latter two vessels had seen many years of service prior to their abandonment. Exactly where any of the vessels were originally built is also unknown, but the use of local timber places their construction close to where they were discovered--somewhere in the South Carolina or Georgia Low Countries.

Dates: No specific dates can be determined for the Malcolm boat or the Clydesdale Plantation sloop; both were stripped prior to abandonment. The Brown's Ferry vessel has been dated to approximately 1740, for it contained artifacts that could be attributed to it with certainty. Like the Brown's Ferry vessel, artifacts found in the Mepkin Abbey shipwreck almost certainly were lost with the vessel and give us a more accurate date of loss of sometime after 1825. Unfortunately more specific dating by dendrochronology is not yet feasible, and there is no funding for C-14 radiocarbon dating. However, with the exception of the Brown's Ferry vessel, all of these vessels were probably in use during the antebellum period (1784-1860).

Dimensions: Table 1 lists the major dimensions of all four vessels. The Brown's Ferry vessel was the longest of the four and also had the largest length:beam ratio. The Malcolm boat was the smallest. The Mepkin Plantation vessel and the Clydesdale Plantation sloop had a similar length:beam ratio, and though the Clydesdale Plantation sloop's length:beam ratio was the smallest, it had the deepest hold, which it needed for storage and stability during off-shore voyages. The Mepkin Abbey wreck probably had

the shallowest hold, but it may have been deeper since the height was estimated on the basis of fragmentary remains above the turn of the bilge. All four vessels had approximately the same tonnage, although the Clydesdale Plantation sloop may have been closer to 20 tons (20,320.9 kg) rather than 25 tons (25,401.2 kg).

Table 1. *Dimensions of Four Early Vessels from the Carolina Low Country*

Name	Length	Beam	Length to Beam Ratio	Depth of Hold	Tonnage
The Mepkin Abbey shipwreck	48 feet, 3 inches (14.71 m)	16 feet, 10 inches (5.13 m)	2.87:1	3 feet, 2 inches (.97 m)	24 tons
The Brown's Ferry vessel	50 feet, 6 inches (15.4 m)	14 feet (4.27 m)	3.6: 1	4 feet (1.2 m)	25 tons
The Clydesdale Plantation sloop	43 feet, 9 inches (13.34 m)	15 feet, 5 inches (4.7 m)	2.84: 1	6 feet, 3 inches (1.9 m)	20-25 tons
The Malcolm boat	41 feet, 10 inches (12.75 m)	11 feet, 9 inches (3.58 m)	3.56:1	4 feet, 11 inches (1.5 m)	24 tons

Construction Method: Only the Brown's Ferry vessel was not built in the frame-first method; it was built using the bottom-based method and featured a heavy keel plank rather than a keel. The most unexpected aspect of the Mepkin Abbey shipwreck was its massive lateral mast step, and the Clydesdale Plantation sloop is unusual because of its framing style.

Materials: Each ship was fastened with iron nails, iron bolts, and wooden trenails. Table 2 shows the woods used in their construction, all of which are found in the Low Country. Live oak, perfect for compass timbers, was the wood of choice at the end of the 18th century for shipyards both in America and in Europe. The southern states began the expensive process of cutting and exporting it, increasing the cost of this very hard and durable wood. The Malcolm boat had live oak end posts, and frames made of both live and white oak, but the other three ships had all of their posts and frames made only of live oak. Live oak was also used for the heavy mast step and the keel of the Mepkin Abbey shipwreck.

The keels of the Clydesdale sloop and the Malcolm boat and the keel plank of the Brown's Ferry vessel were made of southern yellow pine. This pine yielded long and straight timbers with enough sap to make it rot-resistant, but it was far softer and less durable than live oak. Three of the ships also had keelsons made from southern yellow pine, while that of the Brown's Ferry vessel was made of cypress. Cypress was also used for trenails on the Mepkin Abbey shipwreck. Cypress likely was used in earlier colonial times for shipbuilding since those trees were plentiful. They grew primarily along the river banks, and would have been felled to clear fields for rice cultivation making the wood readily available. This was another factor considered in dating the Brown's Ferry vessel.

Table 2. *Woods Used in Ship Construction*

Name	Keel (Keel Plank)	Posts	Frames	Keelson	Planking
The Mepkin Abbey wreck	Live Oak	Live Oak	Live Oak	Southern Yellow Pine	Southern Yellow Pine
The Brown's Ferry vessel	Southern Yellow Pine	Live Oak	Live Oak	Cypress	Southern Yellow Pine
The Clydesdale Plantation sloop	Southern Yellow Pine	Live Oak	Live Oak	Southern Yellow Pine	Southern Yellow Pine
The Malcolm boat	Southern Yellow Pine	Live Oak	Live Oak and White Oak	Southern Yellow Pine	Southern Yellow Pine and Cypress

Propulsion: All of the vessels were sailing craft. The Brown's Ferry vessel, and perhaps also the Malcolm boat, may have carried two masts. The Clydesdale Plantation sloop and the Mepkin Abbey vessel had only single mast steps, but the Mepkin Abbey's step was of exceptionally heavy construction and may have been used to modify a vessel that was originally two masted. Oars and punting poles were found with the Brown's Ferry vessel and it is likely that these alternate modes of propulsion were used on the other craft as well. There is a six foot (1.83 m) tide change in the southeastern Low Country area every six hours, and all of the intercoastal waters abound with sand bars and oyster beds, making grounding a common occurrence.

Purpose: The Clydesdale Plantation sloop was the only vessel among the four that does not appear to have been specifically designed for hauling cargo, although its

hold was made watertight to carry perishable goods. This suggests that it may have been occasionally used to transport rice or some other grain.

Vessels like these were the life-line of the Low Country economy, carrying everything from bulk goods to manufactured materials, and from to animals to people. At one time or another everything was transported as ship-borne cargo during the colonial and antebellum periods. There were few roads during this period and even fewer bridges, while most of the major estuary systems were interconnected along the shore. The sea islands protected a large portion of the coastline, all of which made small sailing craft the most practical means of transportation in this region.

Areas of use: These craft were capable of maneuvering in the coastal waters of the Carolina and Georgia Low Countries, but only the Clydesdale Plantation sloop had a hull deep enough for open ocean sailing. Even then, this sloop would not have been used for long voyages because of its relatively small size and low cargo capacity. The Malcolm boat may have seen a more diverse role, perhaps running passengers from plantation to plantation or into the city of Charleston, while the Mepkin Plantation vessel and Brown's Ferry vessel were almost certainly engaged in the task of hauling heavy goods to and from the market.

In all of these areas: locations, dates, dimensions, construction methods, materials, propulsion, purpose, and areas of use, there are many more similarities in these craft than there are differences. It is only by studying both however, that we are able to expand our knowledge of early American Low Country watercraft.

CONCLUSION

The Function of the Mepkin Abbey Vessel

The Mepkin Abbey vessel had many uses, as any craft of its size and form would have had during this period on the Cooper River. Serving the workers in the rice fields by carrying tools, water, and repair materials to them, may have been one such use. Drew Ruddy lends a supporting conjecture in his report: ‘It is my thought in retrospect that the boat may have been used to tend the rice field banks with the assorted sizes of wood being used for dike maintenance. The significant number of jugs may have been containers for drinking water for the slaves working along the banks. The two hammers may also suggest involvement in a repair or maintenance role’ (Personal Communication, 2001).

Certainly the rice fields were in constant need of repair. There were literally ‘miles of serpentine embankment enclosing thousands of acres of fields’ (Joyner, 1984: 12). Each field had a wooden rice trunk to control the flood of water. Opening the gates at high tide would have flooded the fields, and opening them at low tide would have drained them. A cargo of assorted sizes of lumber would have been needed to repair the rice trunks. The jugs may have held drinking water, as Ruddy surmises. They were all of a utilitarian design, some chipped or damaged, and at least one was as much as 50 years old at the time the ship sank. These would have been the appropriate type of containers to hold drinking water for slaves.

Slaves were the primary labor force and even boatmen were usually slaves, for 'each plantation had certain slaves designated and trained to serve its transportation needs' (Joyner, 1984: 76). Several slave boatmen are mentioned in the Papers of Henry Laurens including: Abram, Achilles, Cuffee, Jemmy, Pompey, Sampson, Scaramouch, and Tom Peas (Hammer and Rogers, eds., 1981; Vol. IV: 633, V: 251). The Mepkin Abbey vessel would have been manned by slaves and whatever work it was being utilized for would also have been carried out by slaves. Designed for work, the Mepkin Abbey vessel was as utilitarian in form and function as the ceramics recovered from its hull.

Interpretations

The materials used to construct the Mepkin Abbey vessel were all available in the South Carolina Low Country. Southern Pine, a light, soft wood, was available for long straight timbers and was used for the construction of the keelson and long strakes of planking. Pine produces a great deal of sap and is therefore rot-resistant, making it an especially good timber for hull planking. Bald cypress, a durable wood, was made into the treenails and was also highly resistant to rot, making the vessel water tight around these fastenings (Steffy 1994: 256-259).

Live oak was considered the best of building materials. It was the wood of choice on the east coast during the 1800s so it became scarce and expensive. It is a dense wood, nearly impervious to rot, and grows in gnarled forms which were perfect for curved timbers. It is also heavier than water making it perfect for shipwrecks as well since the timbers sink and tend to remain in place on the bottom. Conjecturally, the use

of live oak as the primary building material lends itself to either an interpretation of an early construction date, when the material was plentiful, or one that does not heed cost as a consideration during construction, as would have been the case for local boats when the timber did not have to be transported and was therefore less expensive. The Laurens family would have had no problem with either availability of live oak (as the plantation grounds were heavily forested) or of funds.

The fastenings used on the Mepkin Abbey vessel were of both iron and wood. The iron fasteners included bolts, nails with square heads and square shafts, and straps around the sister keelsons and the rudder timbers. The gudgeons and pintles were also of iron. Most of the fastenings, however, were wooden treenails. Treenails are more labor-intensive to install (lots of drilling of holes), but in a salt or brackish water environment would be more durable than iron fastenings. Treenails were used in all four of the wrecks examined. With live oak frames these vessels may have had longer careers than was typical for similar boats using less durable woods.

The Mepkin Abbey wreck was a vessel of approximately 23 tons (23,369.1 kg) capable of carrying 95 barrels of rice as each ton would hold approximately 4 barrels (Fleetwood, 1995: 51). It was very similar to the capacity of the Malcolm boat which William Judd determined to be between 22 and 24 tons (22,353-24,385.1 kg). Judd calculated that the Malcolm boat could hold 81 barrels (Figure 39).

In his 1766 account books (Hammer and Rogers, eds., 1981: Appendix B, 609-612), Henry Laurens places the value of ‘the schooner *Baker* & 4 Negroes on board her’ at £ 2,600. By way of comparison, he places the value of the Wambaw Plantation of

1,500 acres, with dams, buildings, cattle, hogs, horses, at £ 10,000. The plantation schooner *Wambaw*, a 15 ton (15,240.7 kg) contemporary of *Baker* was valued at £ 1,200

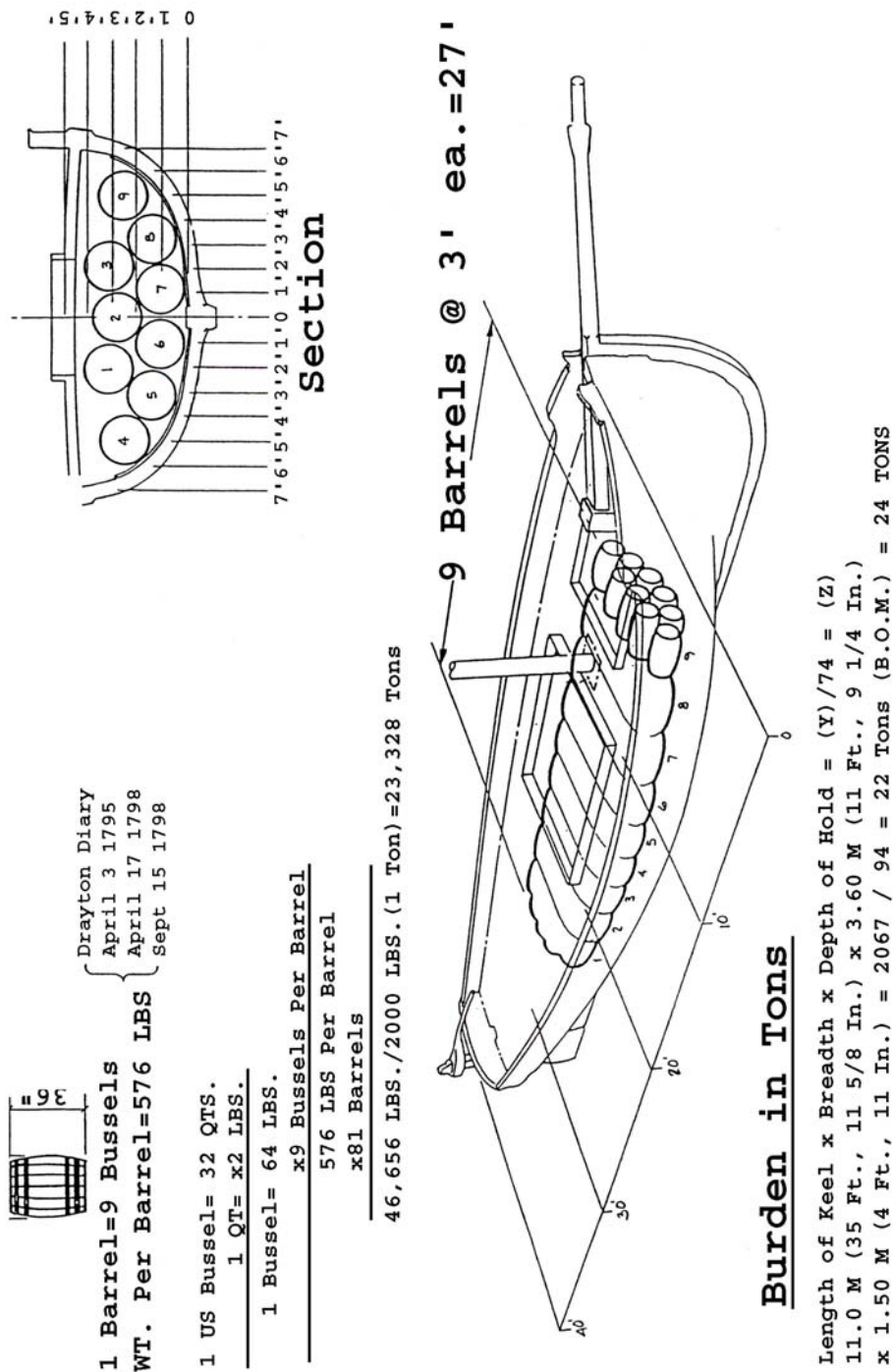

Figure 39. Capacity of the Malcolm Boat (drawing by William R. Judd, courtesy of SCIAA).

and the '5 negroes on board her' at £ 2,000. If the average value of each slave crewman was about £ 400 this would put the value of the *Baker* at £ 1,000 alone. These vessels surely would have been even more expensive after the turn of the century.

The Mepkin Abbey vessel was a working craft. It was shallow and beamy with a length to beam ratio of about 2.87:1. The rice plantations of the times required shallow drafted vessels to work close to the fields. The ship would have had to carry everything from people to lumber, and would have been used to bring all sorts of goods back and forth between the plantation and Charleston. Oyster beds in the coastal areas of South Carolina make it especially difficult for ships with deep drafts to sail during low tide. A shallow-draft boat such as the Mepkin Abbey vessel would have been capable of maneuvering up and down these waterways in almost any tide. It is interesting to note that the vessel lacks a centerboard, a useful feature for shallow-water sailing craft that first appear circa 1825 (Crisman, personal communication, 2004).

The craft was heavily constructed with its notched keelson, solidly framed cargo area, and saddle mast step. The saddle step was a type commonly used on large 18th - century warships (Steffy, 1994: 296) and, according to Kevin Crisman (personal communication 2000), on smaller 18th century watercraft as well. This vessel could have safely carried a very heavy load. But its shallow draft and low freeboard would have made it a poor choice for any but protected inland waters, and it is doubtful if the vessel would ever have been used for lengthy coastal voyages. Although it is nearly impossible to determine the original depth of hold, increasing it by raising the deck would have allowed more cargo capacity, reinforcing the ship's functionality.

Constructed as heavily as it was, and primarily made out of rot resistant live oak, the ship could have had many years of productivity if carefully maintained.

This vessel cannot be dated with any degree of certainty on the basis of its materials, construction methods, and fasteners; dating only on the evidence of the remaining fragments of the vessel give us a range of approximately 150 years, to somewhere in the 18th or 19th centuries. The recovery and documentation of the stoneware jugs allows us to narrow the dating of this vessel to the second quarter of the 19th century.

Recommendations

While further research is needed on early southern watercraft, both in the field and in the historical records, the team at SCIAA is making an impressive contribution in both areas. While the rudder assembly of the Mepkin Abbey shipwreck has been reassembled and returned to the site, where it was reattached to the vessel, the vessel is fully exposed on the bottom of the river. As evidenced from the deterioration since 1980, the Underwater Heritage Trail will not have the wreck for long without some type of repair and regular maintenance. Videos, perhaps even a documentary, would bring the Mepkin Abbey shipwreck to an audience wider than those able to visit the wreck in situ. Even those of us lucky enough to be able to dive on the site are not always able to actually see much of it due to the river's consistently poor visibility and strong currents.

Further historical research could answer many of the questions surrounding the vessel. Although it seems that Henry Laurens' 18th century schooner *Baker* was never registered, many U.S. national vessels of the 19th century were enrolled and researching

the enrollment documents in the U.S. archives might give us additional clues as to the 19th century Mepkin Abbey vessel's origin.

Further archaeological research is needed on other small plantation vessels. Details such as the massive type of mast step seen on the Mepkin Abbey wreck can not generally be found in the archives. It would be interesting to know if saddle mast steps were common on Low Country watercraft, if not this might be a significant clue for determining the shipwright or shipyard that produced the Mepkin Abbey vessel.

As our databases on wood samples improve perhaps the time will come when dating will be possible through dendrochronology. The cargo of wood might be a resource for this type of dating, and samples of it should be recovered, analyzed, and kept for this purpose.

A combination of archaeological and historical research allowed us to significantly expand our knowledge of this vessel. Information of this type greatly benefits the people of Carolina Low Country by adding to their knowledge of local maritime heritage. Knowledge of our local maritime heritage adds to a greater understanding of the importance that maritime history and technology played in the development of our country, and the world, a greater understanding that benefits us all.

REFERENCES

- Amer, C. F., 1993, *The Malcolm Boat (38CH803): Discovery, Stabilization, Excavation, and Preservation of an Historic Sea Going Small Craft in the Ashley River, Charleston County, South Carolina*. Research Manuscript 217: 48, 61, Columbia, South Carolina.
- Amer, C. and Hocker, F. M., 1995, A comparative analysis of three sailing merchant vessels from the Carolina coast, in W. C. Fleetwood, Jr. (ed.), *Tidecraft: The Boats of South Carolina, Georgia and Northeastern Florida, 1550-1950*, 295-303. Tybee Island, Georgia.
- Bass, G. F. (ed.), 1988 (Reprinted 1996), *Ships and Shipwrecks of the Americas*, 124, London.
- Chapelle, H. I., 1935, *The History of American Sailing Ships*, New York.
- Chapelle, H. I., 1951, *American Small Sailing Craft: Their Design, Development, and Construction*, New York.
- Chapelle, H. I., 1975, *American Sailing Craft*, Camden.
- Charleston County Book of Deeds. L12:517, Charleston, South Carolina.
- Chesnutt, D. R. and Taylor, C. J. (eds.), 1999, Introduction, *The Papers of Henry Laurens*, South Carolina, <http://adh.sc.edu/hl/hlessay.html>, August 7, 2003.
- Crisman, K. J., 1988 (Reprinted 1996), Struggle for a continent: naval battles of the French and Indian wars, in G. F. Bass (ed.), *Ships and Shipwrecks of the Americas*, 143-147, London.

- Fleetwood, W. C. Jr., 1995, *Tidecraft: The Boats of South Carolina, Georgia and Northeastern Florida, 1550-1950*, 51-53, Tybee Island, Georgia.
- Haggar, R., 1984, The country potteries of St. Helens and Prescot, *Northern Ceramic Society Journal*, Volume 5, 14-50, London.
- Hamilton, D. L., 2004, Personal Communication, College Station.
- Hammer, P. M. and Rogers, G. C. Jr., (eds.), 1981, *The Papers of Henry Laurens*, Columbia, South Carolina.
- Hocker, F. M., 1992, The Clydesdale Plantation vessel project: 1992 Field Report., *Institute of Nautical Archaeology Quarterly* 19.4, 12-16, College Station, Texas.
- Hume, I. N., 1970 (reprinted 1991), *Artifacts of Colonial America*, 60-61, New York.
- Joyner, C., 1984, *Down by the Riverside: A South Carolina Slave Community*, 12, 76, Chicago.
- Ketchum, W. C. Jr., 1991, *American Stoneware*, 60, New York.
- Oswald, A., Hilyard, F.F.C., and Hughes, R.G., 1982, *English Brown Stoneware: 1670-1900*, Faber and Faber Publishers, 205, London.
- Ramsey, L.G.G., F.S.A. (ed.), 1962, *The Complete Color Encyclopedia of Antiques*, 407, New York.
- Ruddy, D., 2001, Personal Communication: *Abstracts Concerning the Mepkin Abbey Boat Wreck*, Charleston.

Slater, I., 1846, *I. Slater's National Commercial Directory of Ireland: Including, in Addition to the Trades' Lists, Alphabetical Directories of Dublin, Belfast, Cork, and Limerick. To Which are Added, Classified Directories of The Important English Towns of Manchester, Liverpool, Birmingham, West Bromwich, Leeds, Sheffield, and Bristol; and in Scotland, Those of Glasgow, Paisley and Greenock*, 407, London.

Steffy, J. R., 1988 (Reprinted 1996), The thirteen colonies: English settlers and seafarers, in G. F. Bass (ed.), *Ships and Shipwrecks of the Americas*, 124, London.

Steffy, J. R., 1994, *Wooden Ship Building and the Interpretation of Shipwrecks*, 167, 256-259, 296, College Station, Texas.

Wilbanks, R., 1981, A preliminary report on the Mepkin Abbey wreck, Cooper River, South Carolina: An early 19th-century river trading vessel, in G. P. Watts, Jr., (ed.), *Underwater Archaeology: The Challenge Before Us. The Proceedings of the Twelfth Conference on Underwater Archaeology*, 151-157, San Marino.

APPENDIX A

SCANTLINGS OF THE MEPKIN ABBEY WRECK (Metric)

Length: between perpendiculars	14.71 m
Beam: (estimated)	5.13m
Length-to-beam ratio: (estimated)	2.87-1
Height: (estimated - from rabbet to sheer at midships)	1.47 m
Depth of Hold: (estimated)	.97m
Draft at LWL: (estimated)	.9 m
Tonnage: (estimated)	(95 barrels of rice) 23.65 tons

* Denotes actual dimensions as measured in 2000 (original surface or very little erosion)

Appendix A, Table 1.

TIMBER	LENGTH	MOLDED	SIDED	HEIGHT	WOOD
Keel	12.57 m	.05-.25 m	.15-.25 m		
Stempost	*3.17 m	.18-.34 m	.15 m	*2.03 m	live oak
Upper Apron	2.26 m	.08-.13 m	.15 m		
Apron	2.343 m	.13-.20 m	.15-.22 m		
Deadwood	3 m	.23-.45 m	.15-.22 m		
Stern Knee	1.36 m	.12-.40 m	.15 m		
Stern post		.22-.30 m	.15 m	*2.34 m	live oak
Floors		.10-.15 m	.10-.13 m		live oak
Futtocks		.15 m	.10-.13 m		live oak
Mast step	*1.70 m	*.35 m	*.25 m		live oak
Keelson	*10.83 m	.13-.27 m	.15-.25 m		so. yellow pine
Sister Keelsons	*1.03 m	*.15 m	*.12 m		
Step Brace Aft	*.47 m	*.13-.17 m	*.10 m		

Appendix A, Table 1 Continued

TIMBER	LENGTH	MOLDED	SIDED	HEIGHT	WOOD
Step Brace Fore	.35 m	.125 m	.10 m		
Stanchions		.10-.11 m	.06 m		
Planking		*025-.04 m	*.16-.26 m		So. pine
Wales		.04-.06 m	.28 m		
Garboard strake		.05 m	.26 m		
Rudder		*.11 m	*1.23 m	*1.63 m	
Rudder Post		.24- .25 m	.15 m	2.52 m	
Beams		.12 m	.15 m		
Ceiling		.02-.03 m	.26 m		
Deck planking		.02-.03 m	.15 m		
Cap rail		.06 m	.24 m		
Shelf clamp		.28 m	.08 m		
Lodging knees	.7 m	.13 m	.13 m		
Limber holes		.03 m	.05-.06 m		
Sampson post		.10 m	.15 m	1.76 m	
Bow sprit			.15-.16 m dia.		
Carlings		.16 m	.12 m		
Combing		.13 m	.08-.09 m		
Mast			.25-.24 m dia.		
Treenails			.03 m		Bald cypress

HULL COEFFICIENTS

Block Coefficient	.57
Prismatic Coefficient	.61
Waterplane Coefficient	.73
Midship Section Coefficient	.93

APPENDIX B

SCANTLINGS OF THE MEPKIN ABBEY WRECK (Imperial)

Length: between perpendiculars	48 feet, 3 inches
Beam: (estimated)	16 feet, 10 inches
Length-to-beam ratio: (estimated)	2.87 - 1
Height: (estimated - from rabbet to sheer at midships)	4 feet, 10 inches
Depth of Hold: (estimated)	3 feet, 2 inches
Draft at LWL: (estimated)	2 feet, 11 inches
Tonnage: (estimated)	(95 barrels of rice) 23.65 tons

* Denotes actual dimensions as measured in 2000 (original surface or very little erosion)

Appendix B, Table 1.

TIMBER	LENGTH	MOLDED	SIDED	HEIGHT	WOOD
Keel	41 feet 3 inches	2-10 inches	6-10 inches		
Stempost	*10 feet 5 inches	7-13 inches	6 inches	*6 feet 8 inches	live oak
Upper Apron	7 feet 5 inches	3-5 inches	6 inches		
Apron	7 feet 8 inches	5-8 inches	6-9 inches		
Deadwood	9 feet 8 inches	9-18 inches	6-9 inches		
Stern Knee	4 feet 6 inches	5-16 inches	6 inches		
Stern post		9-12 inches	6 inches	7 feet 8 inches	live oak
Floors		4-6 inches	4-5 inches		live oak
Futtocks		6 inches	4-5 inches		live oak
Mast step	*5 ft 7 inches	*1 ft 2 inches	*10 inches		live oak
Keelson	*35 ft 6 inches	5-11 inches	6-10 inches		so. yellow pine

Appendix B, Table 1 *Continued*

TIMBER	LENGTH	MOLDED	SIDED	HEIGHT	WOOD
Step Brace Aft	*1 feet 6.5 inches	*5-7 inches	*4 inches		
Step Brace Fore	*1 feet 2 inches	*5 inches	*4 inches		
Stanchions		4 inches	2 inches		
Sister Keelsons	*3 feet 4.5 inches	*6 inches	*5 inches		
Planking		*10-18 inches	*6-10 inches		southern pine
Wales		1.5-2 inches	11 inches		
Garboard strake		2 inches	10 inches		
Rudder		*4 feet 2 inches-1 foot 5 inches	*6 inches	*5 feet 4 inches	
Rudder Post		10 inches	6 inches	8 feet 3 inches	
Beams		5 inches	6 inches		
Ceiling		1 inch	10 inches		
Deck planking		1 inch	6 inches		
Cap rail		2 inches	9.5 inches		
Shelf clamp		11 inches	3 inches		
Lodging knees	2 feet 4 inches	5 inches	5 inches		
Limber holes		1 inch	2 inches		

Appendix B, Table 1 *Continued*

TIMBER	LENGTH	MOLDED	SIDED	HEIGHT	WOOD
Sampson post		4 inches	6 inches	5 feet 9 inches	
Bow sprit			6 inches dia.		
Carlings		6 inches	5 inches		
Cowlings		5 inches	3 inches		
Mast			10-9.5 inches diameter		
Treenails			1 inch diameter		bald cypress

HULL COEFFICIENTS

Block Coefficient	.57
Prismatic Coefficient	.61
Waterplane Coefficient	.73
Midship Section Coefficient	.93

APPENDIX C

MEPKIN ABBEY SHIPWRECK HULL CALCULATIONS (METRIC)

Appendix C, Table 1.

	AREAS (m²)	
SECTION Ø	AREA = 2.86	$2[(1.9+2.34) / 2 \times .45 + (2.34 + 2.4) / 2 \times .2] = 2.86$
B0	1.9	
B1	2.34	
B2	2.4	
H1	.45	
H2	.2	
SECTION A	AREA = 2.56	$2[(1.5+2.19) / 2 \times .45 + (2.19+2.3) / 2 \times .2] = 2.56$
B0	1.5	
B1	2.19	
B2	2.3	
H1	.45	
H2	.2	
SECTION B	AREA = 1.59	$2[(.18+1.74) / 2 \times .45 + (1.74+1.90) / 2 \times .2] = 1.59$
B0	.18	
B1	1.74	
B2	1.90	
H1	.45	
H2	.2	
SECTION 1	AREA = 2.04	$2[(.44+2.15) / 2 \times .45 + (2.15+2.24) / 2 \times .2] = 2.04$
B0	.44	
B1	2.15	
B2	2.24	
H1	.45	
H2	.2	
SECTION 2	AREA = 1.5	$2[(.12+1.66) / 2 \times .45 + (1.66+1.86) / 2 \times .2] = 1.5$
B0	.12	
B1	1.66	
B2	1.86	
H1	.45	
H2	.2	

Appendix C, Table 2.

LENGTHS BETWEEN SECTIONS (meters)	
LENGTH	LENGTH
LOB = 2.32	LØ1 = 2.08
LBA = 1.46	L12 = 3.2
LAØ = 2.06	L2T = 2.46

Appendix C, Table 3.

VOLUME (m3)		
SECTIONS		VOLUME OF SECTIONS =22.65
A0-AB	$(1.59+0) / 2 \times 2.32 = 1.84$	1.84
AB-AA	$(1.59 + 2.56) / 2 \times 1.46 = 3.03$	3.03
AA-AØ	$(2.56 + 2.86) / 2 \times 2.06 = 5.58$	5.58
AØ-A1	$(2.86 + 2.04) / 2 \times 2.08 = 5.1$	5.1
A1-A2	$(2.04 + 1.5) / 2 \times 3.20 = 5.66$	5.66
A2-AT	$(1.5 + 0) / 2 \times 2.46 = 1.44$	1.44
SUB TOTAL	$1.84 + 3.03 + 5.58 + 5.1 + 5.66 + 1.44 = 22.65$	22.65
STEM B=.26 H=.15/ L=3.17	$.26 \times .15 \times 3.17 = .12$	VOLUME OF STEM = .12
KEEL B=.25 H=.25 L=12.57	$.25 \times .25 \times 12.57 = .79$	VOLUME OF KEEL = .79
STERN POST B=.26 H=.15 L=2.34	$.26 \times .15 \times 2.34 = .09$	VOLUME OF STERN POST = .09
TOTAL	$22.65 + .12 + .79 + .09 = 23.65$	TOTAL VOLUME (T) = 23.65

Appendix C, Table 4.

HULL COEFFICIENTS		
CB (BLOCK COEFFICIENT)	$23.65 / (13.58 \times 4.72 \times .65) = .57$.57
CP (PRISMATIC COEFFICIENT)	$23.65 / (2.86 \times 13.58) = .61$.61
CW (WATERPLANE COEFFICIENT)	$2[(1.9 \times 2.32) + (2.3 \times 1.46) + (2.4 \times 2.06) + (2.24 \times 2.08) + (1.86 \times 3.2) + (0 \times 2.46)] = .73$.73
CM (MIDSHIP SECTION)	$2.86 / .65 \times 4.72 = .93$.93
BEAM @ (T) MIDSHIPS	(with planking) 4.72 m	4.72
AREA (T) AMIDSHIPS	2.86 m ²	2.86
DRAFT (T) @ LWL	(without keel) .65 m	.65
LENGTH AT LWL	13.58 M	13.58

VITA

Susan Lynn Vezeau
104 Battery Circle
Yorktown, VA 23692

Education

Master of Arts Degree: August 2004, Texas A&M University, College Station, Texas, Department of Anthropology (Specialization in Nautical Archaeology).

Bachelor of Science Degree: December 1999, College of Charleston, Charleston, South Carolina, Anthropology major (Specialization in Archaeology), Psychology minor.

Career Positions

- 2003- Present Program Director/Archaeologist for the Jamestown 4-H Educational Center, funded by Virginia Polytechnic Institute and State University.
- 2002-2003 Nautical Archaeologist / National Submerged Cultural Resource Database Coordinator, funded by NOAA's National Marine Sanctuary Program and Office of Ocean Exploration.
- 2001-2002 Submerged Cultural Resource Coordinator/Underwater Archaeologist and Conservator for the Santa Barbara Maritime Museum, funded in part by NOAA's National Marine Sanctuary Program.

Conferences and Publications

- 2003 World Archaeology Conference (WAC 5): Presented and Published on the Pacific Coast Maritime Archaeology Summary Project and the NOAA Maritime Archaeology Center's MARINER Database Project.
- 2003 NOAA's Gulf Regional Database Development Workshop: Conference Coordinator and major presenter.
- 2003 Society for Historical Archaeology: Pacific Coast Maritime Archaeology Summary Project and NOAA's National Database Project.
- 2002 California World Oceans Conference: Pacific Coast Maritime Archaeology Project.
- 2002 Pacific Coast Database Development Workshop: Conference Coordinator, major presenter.
- 2002 PCMAS.ORG: Web site Publication of the PCMAS report and databases.
- 2002 Society for Historical Archaeology (SHA): Poster session on the 'Mepkin Abbey Shipwreck.'