

THE NEW JET 9

AMPLIFIED XC



THE NEW JET 9 - ALLOY RARIFIED, MTB PERSONIFIED, LIFESTYLE SIMPLIFIED

- AIRFORMED ALLOY FULL SUSPENSION FROM THE 29ER-ONLY MOUNTAIN BIKE COMPANY
- 100MM OF PATENTED CVA SUSPENSION IS EFFICIENT IN EVERY CHAINRING
- COMPATIBLE WITH 100-120MM FORKS
- TUNED FOR CVA - ROCK SHOX MONARCH RT3 HV
- ENDURO SEALED CARTRIDGE PIVOT BEARINGS
- FORGED SUSPENSION LINKAGE AND UNIQUE NINER ALLOY HARDWARE
- 142MM X 12MM REAR SPACING



WWW.NINERBIKES.COM/JET9

THE NEW JET 9



THE NEW JET 9

Life is complicated enough from nine to five, what you do in your off hours should be simple – it's time to hit the trail on the new Jet 9. Enter your first mountain bike race, visit that MTB mecca or just crush souls on the after-work ride. It's the simple action of "doing" that's important and that is why we created the new Jet 9.

Serious good looks, lighter weight, more CVA travel, the Jet 9 has all the technical refinements that define an XC dominator. Carbon wonder-bikes are great, but you'll appreciate the new technologies that we utilize in our alloy frames, too. They are dream bikes within reach – Airformed alloy with as many custom details as our RDO line, something you can log big miles on, day in and out. Sound like a bike that you might want in the garage? Yeah, us too.

XC FULL SUSPENSION

The Niner that loves putting the pedal to the metal – The JET 9 is for riders who like to get there sooner or ride just a bit further. With over 30 glowing media reviews for ride quality and handling - the new JET 9 takes these characteristics and ups the ante with increased travel, a 142x12mm rear end and airformed aluminum alloy tubes that redefine performance and reduce frame weight.

CVA™ SUSPENSION

The JET 9 features Niner's patented CVA suspension (U.S. Patent No. 7,934,739) and delivers 100mm of fully active travel with superb compliance and damping via a tuned for CVA RockShox Monarch RT3 HV shock. For those seeking the technical advantages of 29" wheels combined with pedaling efficiency across all chainring combinations (not just the middle ring), CVA™ is the front-runner. The result? A faster, smoother ride up and down the trail.

VERSATILE GEOMETRY

To achieve maximum efficiency you need predictability, balance and nimble handling. Niner is the company that helped make fun and fast 29ers a reality. Climbing or descending, the geometry of the JET 9 is tuned to keep you in control and ready to conquer new terrain at every turn. The JET 9 is intended for 100 to 120mm forks, allowing riders to further fine tune the ride.

AIRFORMED TUBING

The new JET 9 frame sheds approximately 1/4 pound from the last model. To achieve this reduction and actually increase strength we looked beyond traditional hydroforming. Shaping the frame tubes with compressed air in a heated mold gives us greater control over wall thickness and material uniformity, allowing the use of less metal. Tubes that are manipulated using this process can be up to 25% lighter than a similar hydroformed shape at the same strength.

TAPERED HEADTUBE

The increased surface area of a tapered headtube allows for a larger downtube, increasing strength and rigidity at this critical intersection. Tapered fork steerer tubes measurably reduce fork deflection, which means your Niner tracks straight and true. The full spectrum of riders from XC racers to All Mountain shredders benefit from these features which is why we incorporate the technology in all our frames.

ATTENTION TO DETAIL

From the head tube to the rear axle, we looked at every single detail and asked "can it be done better?" We've revised the shapes of the forged yokes and attachments, subjecting them to mechanical and real world testing to ensure they're as light and strong as possible. New linkage shapes increase strength and stiffness and shed a few more grams, the lower link has a pronounced asymmetrical form to increase chainstay clearance. Saving weight doesn't mean skimping - pivots are still outfitted with Enduro Max full complement sealed cartridge bearings for smooth, friction-free suspension.



WWW.NINERBIKES.COM/JET9

THE NEW JET 9 - SPECS



JET 9 SPECIFICATIONS & COMPATIBILITY

PF30 Bottom Bracket Shell (73mm width)
Shock size: 7.5"(190mm) x 2.0"(50mm) - 4"(100mm) travel
Shock mounting hardware width: 22.2mm x M6
Shock SAG: 25% (which will move the o-ring 12.5mm down the shaft)
30.9mm seat post, 370mm length recommended, compatible with external routing dropper posts
34.9mm seat collar
S3 (low) direct mount front derailleur, top pull
1.125"- 1.5" tapered headtube with integrated (Campy style) headset (headset included) Cane Creek standard description: IS42/28.6 IS52/40
Enduro Max sealed bearings - (8x) 22x10x6mm
142x12mm rear spacing
Extra Small has one bottle mount under the downtube. Small, Medium, Large and XL have one inner triangle bottle mount and one under the DT bottle mount.
Can fit up to a 2.35" tire (tire size varies by brand, some tires may not fit)
Compatible with most standard 1x, 2x and 3x chainring systems.



CONTACT YOUR NINER DEALER FOR DETAILS AND TO PLACE AN ORDER.

THE NEW JET 9 - STAR BUILDS & PRICING

STAR BUILDS



JET 9 ★★★★★ XO	
FRAME	NINER JET 9, TAMALE
FORK	ROCKSHOX SID XX SOLO AIR 100MM, REMOTE LOCKOUT, 15MM
WHEELSET	AMERICAN CLASSIC RACE29, 15MM FRONT, 135MM X QR REAR
TIRES	SCHWALBE RAPID ROB EVO TL 2.40/RACING RALPH EVO TL 2.25, NINER GRAPHIC
BRAKES & ROTORS	SRAM XO CARBON WITH 180/160MM HS1 ROTORS
BRAKE LEVERS	SRAM XO CARBON
R/SHIFTER	SRAM XO 10SP MMX CLAMP
F/SHIFTER	SRAM XO 2SP MMX CLAMP
R/DERAILLEUR	SRAM XO MED CAGE, 10SP TYPE 2
F/DERAILLEUR	SRAM XO 10SP
CASSETTE	SRAM PG 1070 10SP 11-36T
CHAIN	SRAM PC 1051
CRANK SET	SRAM XO PF30, 38/24T
BOTTOM BRACKET	SRAM PF30
SADDLE	WTB VOLT TEAM WITH NICO RAILS, NINER GRAPHIC
SEATPOST	NINER 370MM CARBON SEAT POST, RED NINER GRAPHIC
HANDLEBAR	NINER FLAT TOP RDO, 710MM, RED NINER GRAPHIC
STEM	NINER RDO STEM, RED NINER GRAPHIC
GRIPS	NINER GRRRIPS



WWW.NINERBIKES.COM/JET9

THE NEW JET 9 - STAR BUILDS & PRICING

STAR BUILDS



JET 9 ★★ ★★ XT	
FRAME	NINER JET 9, ARCTIC WHITE
FORK	ROCKSHOX SID RL SOLO AIR 100MM, 15MM
WHEELSET	NOTUBES 3.30/ZTR ARCH EX, 15MM FRONT, 135MM X QR REAR
TIRES	SCHWALBE RAPID ROB EVO TL 2.40/RACING RALPH EVO TL 2.25, NINER GRAPHIC
BRAKES & ROTORS	SHIMANO XT M785 ICE TECH PADS WITH 180/160MM ROTORS
BRAKE LEVERS	SHIMANO XT M785
R/SHIFTER	SHIMANO XT M780 10SP I-SPEC
F/SHIFTER	SHIMANO XT M780 2/3SP I-SPEC
R/DERAILLEUR	SHIMANO XT M786 GS MED CAGE 10SP SHADOW PLUS
F/DERAILLEUR	SHIMANO XT M785 10SP
CASSETTE	SHIMANO XT M771 10SP 11-36T
CHAIN	SHIMANO XT HG95 10SP
CRANK SET	SHIMANO XT M785 38/26T
BOTTOM BRACKET	SHIMANO XT BB70
SADDLE	WTB VOLT RACE WITH CR-MO RAILS, NINER GRAPHIC
SEATPOST	NINER 370MM CARBON SEAT POST, RED NINER GRAPHIC
HANDLEBAR	NINER FLAT TOP CARBON, 710MM, RED NINER GRAPHIC
STEM	NINER ALLOY STEM, RED NINER GRAPHIC
GRIPS	NINER GRRRIPS

JET 9 ★★ SLX/DEORE	
FRAME	NINER JET 9, ARCTIC WHITE
FORK	FOX 32 FLOAT CTD O/C EVOLUTION, 100MM, 15MM
WHEELSET	AMERICAN CLASSIC TERRAIN, 15MM FRONT, 135MM X QR REAR
TIRES	SCHWALBE RACING RALPH PERFORMANCE 2.25
BRAKES & ROTORS	SHIMANO DEORE M615 WITH 180/160MM ROTORS
BRAKE LEVERS	SHIMANO DEORE M615
R/SHIFTER	SHIMANO SLX M670 10SP I-SPEC
F/SHIFTER	SHIMANO SLX M670 2/3SP I-SPEC
R/DERAILLEUR	SHIMANO SLX M675 SGS LONG CAGE 10SP SHADOW PLUS
F/DERAILLEUR	SHIMANO DEORE M610 10SP
CASSETTE	SHIMANO HG62 10SP 11-36T
CHAIN	SHIMANO HG54 10SP
CRANK SET	SHIMANO DEORE M612 22X30X40T
BOTTOM BRACKET	SHIMANO BB70
SADDLE	WTB VOLT SPORT, NINER GRAPHIC
SEATPOST	NINER 370MM ALLOY SEAT POST, RED NINER GRAPHIC
HANDLEBAR	NINER FLAT TOP ALLOY, 710MM, RED NINER GRAPHIC
STEM	NINER ALLOY STEM, RED NINER GRAPHIC
GRIPS	NINER GRRRIPS



MODEL	MSRP
JET 9 FRAMESET	\$1,849
JET 9 ★★ ★★ ★★ XO	\$4,899
JET 9 ★★ ★★ XT	\$4,199
JET 9 ★★ SLX/DEORE	\$3,099

CONTACT YOUR NINER DEALER FOR DETAILS AND TO PLACE AN ORDER.



THE NEW JET 9 - GEOMETRY

JET 9	UNITS	A - TT LENGTH		B - SEAT TUBE LENGTH		C - CHAINSTAY LENGTH		D - HORIZ. CHAINSTAY		E - FRONT CENTER		F - WHEELBASE		G - BB DROP		H - HEAD TUBE LENGTH		I - HEAD TUBE ANGLE		J - SEAT TUBE ANGLE		K - STANDOVER HEIGHT		L - REACH		M - STACK	
		100	120	100	120	100	120	100	120	100	120	100	120	100	120	100	120	100	120	100	120	100	120	100	120	100	120
FORK		100	120																								
XS	MM	559	562	391	455	454	632	637	1084	1091	35	27	100	71.0	70.0	74.0	73.0	699	705	392	381	591	597				
SM	MM	578	581	406	455	454	651	657	1104	1111	35	27	110	71.0	70.0	74.0	73.0	707	714	408	398	600	607				
MD	MM	595	598	458	455	454	663	669	1116	1122	35	27	120	71.0	70.0	74.0	73.0	748	755	422	411	611	619				
LG	MM	615	618	508	455	454	684	689	1136	1143	35	27	130	71.0	70.0	74.0	73.0	784	792	439	428	621	629				
XL	MM	635	638	559	455	454	704	710	1157	1164	35	27	145	71.0	70.0	74.0	73.0	820	828	455	445	635	643				

XS	INCH	22.0	22.1	15.4	17.9	17.9	24.9	25.1	42.7	43.0	1.4	1.1	3.9	71.0	70.0	74.0	73.0	27.5	27.8	15.4	15.0	23.3	23.5				
SM	INCH	22.8	22.9	16.0	17.9	17.9	25.6	25.9	43.5	43.7	1.4	1.1	4.3	71.0	70.0	74.0	73.0	27.8	28.1	16.1	15.7	23.6	23.9				
MD	INCH	23.4	23.5	18.0	17.9	17.9	26.1	26.3	43.9	44.2	1.4	1.1	4.7	71.0	70.0	74.0	73.0	29.4	29.7	16.6	16.2	24.1	24.4				
LG	INCH	24.2	24.3	20.0	17.9	17.9	26.9	27.1	44.7	45.0	1.4	1.1	5.1	71.0	70.0	74.0	73.0	30.9	31.2	17.3	16.9	24.4	24.8				
XL	INCH	25.0	25.1	22.0	17.9	17.9	27.7	28.0	45.6	45.8	1.4	1.1	5.7	71.0	70.0	74.0	73.0	32.3	32.6	17.9	17.5	25.0	25.3				

*Geometry measurements are shown for 100mm and 120mm travel forks.

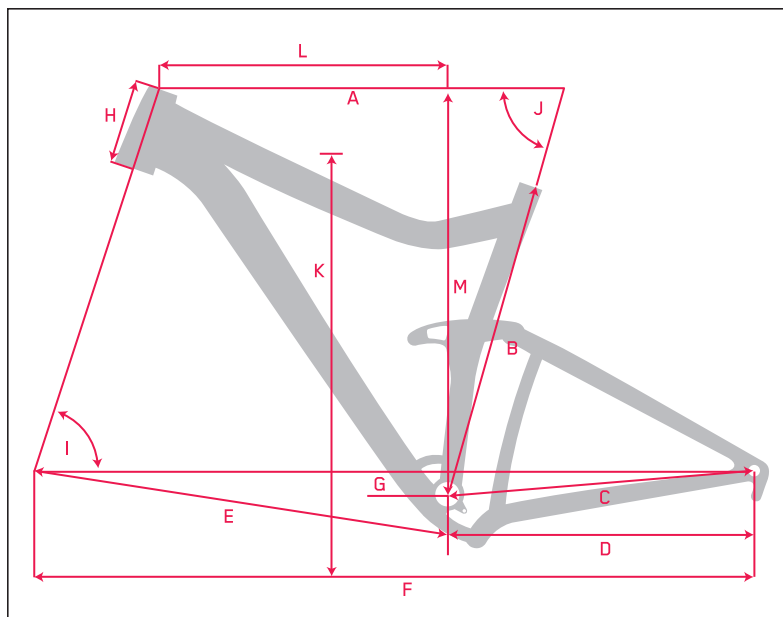

HEIGHT RECOMMENDATIONS				
XS (available in select models)	S	M	L	XL
5'0"-5'5" 1.53-1.65m	5'3"-5'9" 1.6-1.75m	5'8"-6' 1.73-1.83m	5'11"-6'3" 1.8-1.91m	6'3"-6'7" 1.91-2.01m

For riders who fall between sizes we recommend sizing down for a more maneuverable ride or sizing up for more stability. The best way to determine which size is for you is to test ride a Niner at one of our dealers or demo events.

- Geometry key:
- (A) EFFECTIVE TOP TUBE LENGTH
 - (B) SEAT TUBE LENGTH
 - (C) CHAINSTAY LENGTH
 - (D) HORIZ. CHAINSTAY
 - (E) FRONT CENTER
 - (F) WHEELBASE
 - (G) BB DROP
 - (H) HEAD TUBE LENGTH
 - (I) SEAT TUBE ANGLE
 - (J) HEAD TUBE ANGLE
 - (K) STANDOVER
 - (L) REACH
 - (M) STACK

WWW.NINERBIKES.COM/JET9