



The Riddle of the Exporter

Transportation & Logistics



Topics covered:

- Your BFF-The Freight Forwarder
- Regulatory Requirements
- Modes of Transport and Shipment Routing
- Packing Requirements
- Incoterms
- Documents
- AES Filing
- ATA Carnets
- Insurance



© www.123f.com



Alphabet of Acronyms

- AES-Automated Export System
- BL-Bill of Lading
- COO-Certificate of Origin
- EEI-Electronic Export Information
- FCL/LCL-Full Container Load & Less Than Container Load
- SED-Shipper's Export Declaration
- TEU/FEU-20' equivalent unit & 40' equivalent unit
- ULD-Unit Loading Device
- USPPI-U.S. Principal Party of Interest
- **INCOTERMS**
- EXW-Ex Works
- FCA-Free Carrier (named place)
- FAS-Free Alongside Ship (named port of shipment)
- FOB-Free On Board (name port of shipment)
- CFR-Cost & Freight (named port of destination)
- CIF-Cost, Insurance & Freight (named port of destination)
- CPT-Carriage Paid To (named port)
- CIP-Carriage, Insurance Paid To (port)
- DAP-Delivered at Place (named place)
- DAT-Delivered at Terminal (named place or terminal)
- DDP-Delivered Duty Paid (named place of destination)

Your Freight Forwarder is Your New BFF

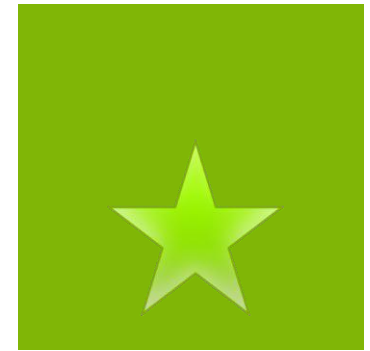

- **Expectations of a Freight Forwarder**
 - Freight Forwarder- an agent who arranges the transport of goods for others.
- **Role of Freight Forwarder**
 - Handle details and documentation
 - Aware of regulations
 - Checks the lists
 - Prepares and files the EEI with the AES



Primary Parties in an Export Transaction

- Seller/Buyer/Manufacturer- USPP (usually)
- Banks/Finance/Insurance Broker
- Shipper/Consignee
- Consolidator/Forwarder
- Railroads
- Truckers
- Stevedores (Longshoremen)
- Steamship Lines/Airlines
- Customs Brokers
- Government Agencies/Security
- Warehouse/Distribution
- Exporter/Importer of Record
- Ultimate Consignee

Before You Start... Check the Regs!

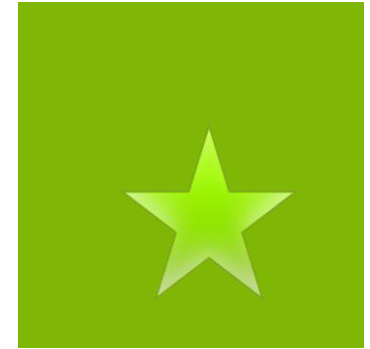

- Foreign Regulatory Requirements
- Check the lists:
 - OFAC
 - BIS
 - CCL
 - CCC
 - SDN
- Does it require a special certificate of origin (Israel, NAFTA, Nigeria to name a few)?
- Will it require consular stamps and signatures (some Middle Eastern countries)?
- ISPM15 – Will it require special pallets or fumigation?



Modes of Transportation

Ocean

- Best for large, consolidated shipments
- Very economical but long transit times
- Variety of container sizes, 20, 40, 45, and high cubes
- Can Move as Full Containers (FCL) or Less than Container Loads (LCL)



Modes of Transportation

Ocean \$\$

- Ocean rates are calculated based on:
 - Type of load and commodity
 - FCL vs. LCL
 - Accessorial charges apply:
 - Fuel-BAF Bunker Adj. Factor, PSS-Peak Season Surcharge, THC-Terminal Handling Charges, Demurrage, IPI-Inland Points Included, Canal Charges

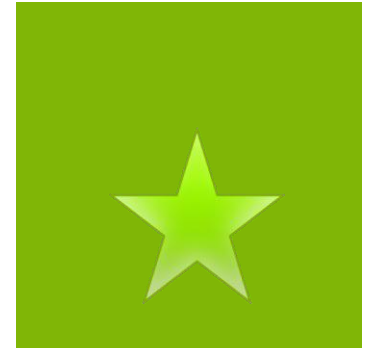

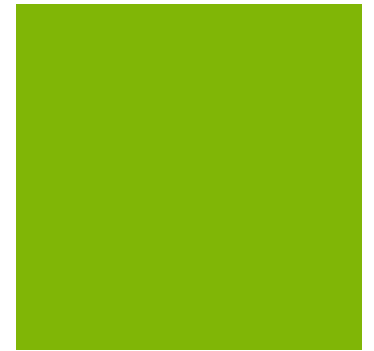

Modes of Transportation

Air

- More expensive than ocean
- Best for smaller, time-sensitive shipments
- Good for regular, high-value consignments
- Size and weight limitations



Modes of Transportation

Air \$\$\$

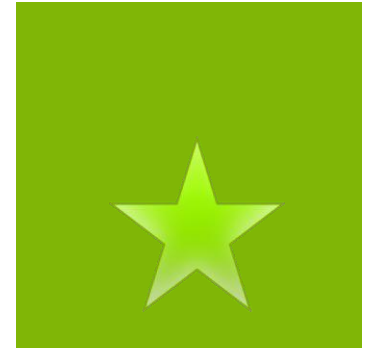

- Air freight rates are based on the size of the shipment
- Air Freight volume is calculated $L \times W \times H / 366$
 - Weight or Volume-whichever is greater
- Accessorial Charges include but are not limited to:
 - Inland freight, Handling, ISS, FSC (Fuel Surcharge), AES Fee



ULD-Unit Loading Device

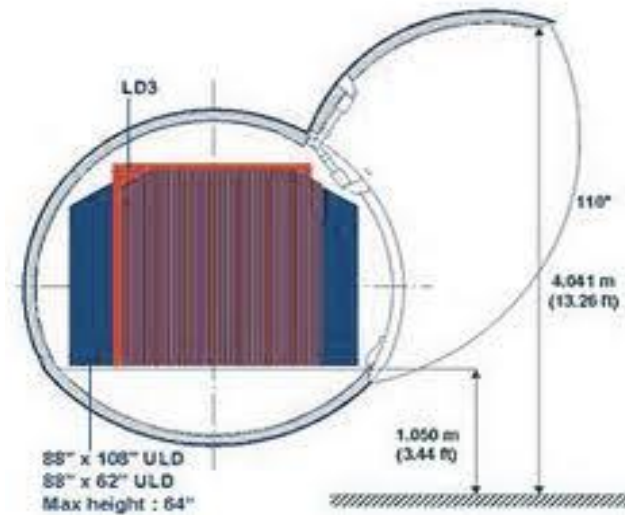
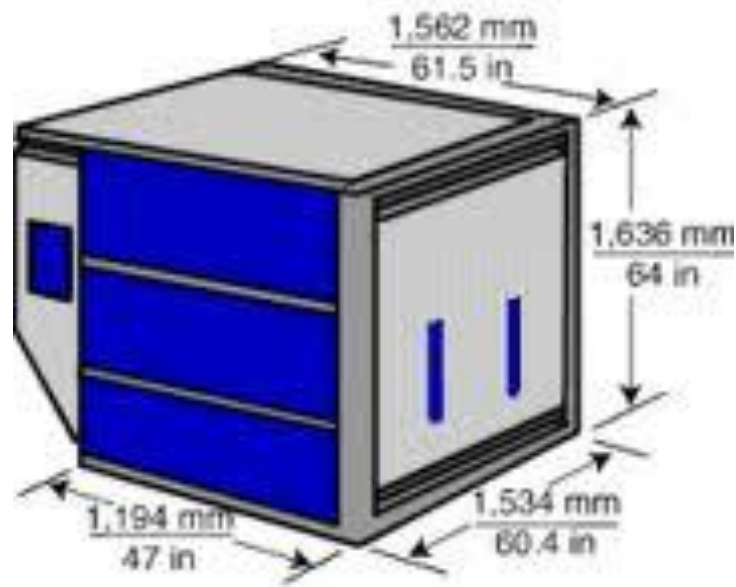

Modes of Transportation

Rail & Truck

Rail

- Weight up to 3000 metric tons
- Flatbed rail cars, TOFC-(trailer on flat car) or
- COFC (container on flat car)
- ** CL, FCL and LCL in rail refer to carload
- Quoted on weight, distance and commodity

Truck

- 50-80% of cross border deliveries
- Quoted weight, distance and commodity
- **road size and weight limits vary by state

Cannot Get a Freight Quote Without These!

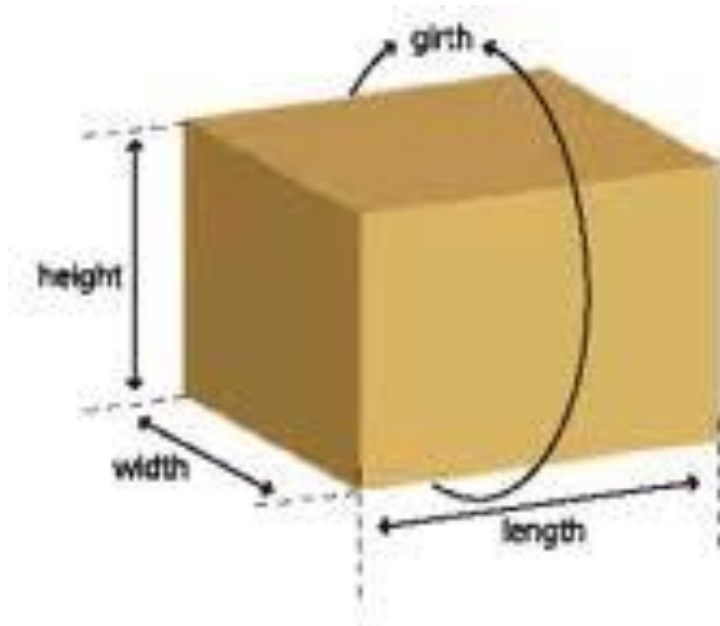

Metric Please!

Small Shipments



- Excellent program if the postal service is good in the other country.
- Excellent program for return if refused.



Packing Requirements

- UNDERSTAND THE MODE OF TRANSPORTATION FIRST
 - A package may be handled between 24 and 71 times.
 - Can it withstand a 2 meter fall, it will be dropped?
 - Can it withstand cold, heat and cold again?
 - Can it withstand the weight of overstacking?
- Marking of boxes
 - “Don’t advertise “Expensive Nike Shoes”



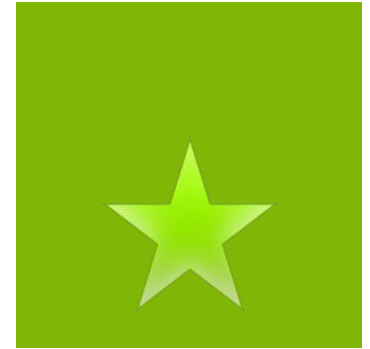

Incoterms 2010

- Worldwide program of acronyms of rules that describe the task, cost and risks involved in transferring the good from seller to buyer.
- Commonly used Incoterms:
 - **FOB** (Free on Board)...
 - **CIF** (Cost Insurance & Freight)
 - **EXW (Exworks)**...
 - **DDP** (Delivered Duty Paid)

Incoterms are NOT:

- Terms of payment that dictate HOW or WHEN you get paid
- Contract of Sale
- Contract of Carriage



Insurance liability, assumption of risks
and costs pursuant to Incoterms® 2010

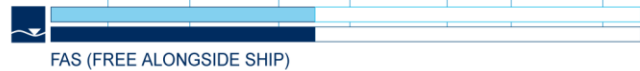
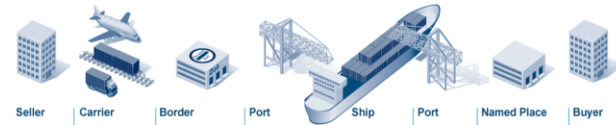
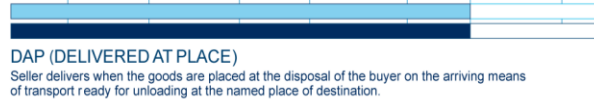
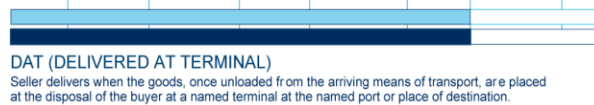
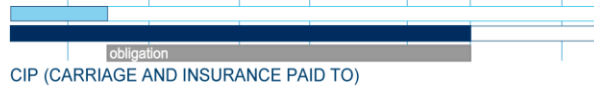
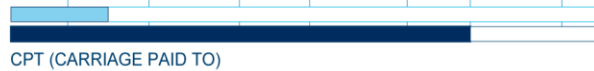

- The risk is borne by the seller
- The costs are borne by the seller
- Transport insurance is the responsibility of the seller
- The risk is borne by the buyer
- The costs are borne by the buyer
- Clauses for sea and inland water transport

Incoterms



Incoterms 2010 Estructura



ICC rules for the use of domestic and international trade terms

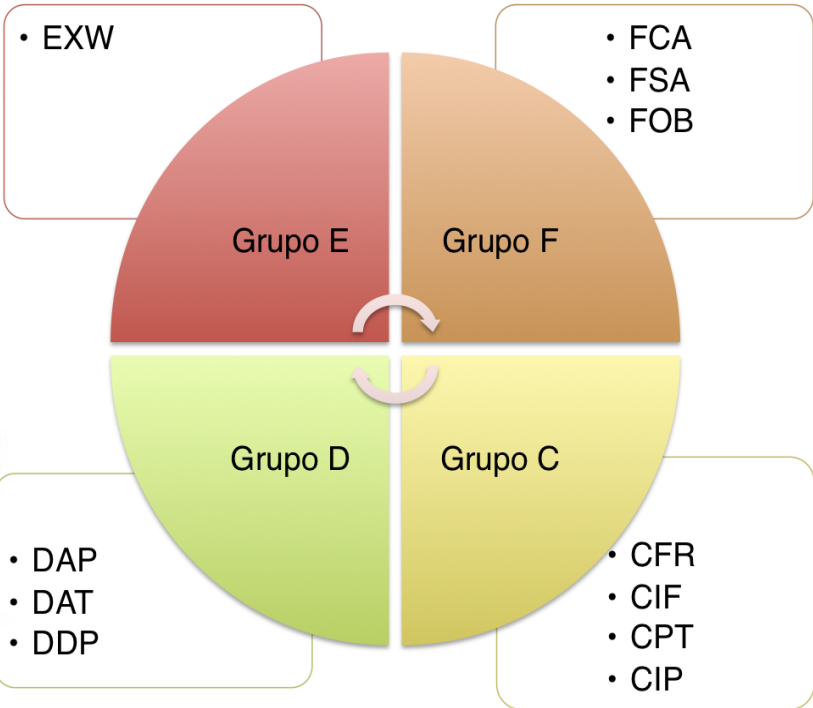

imeridag@gmail.com

Grupo E	Departure	Grupo F	Main carriage unpaid
Grupo D	Arrival	Grupo C	Main carriage paid

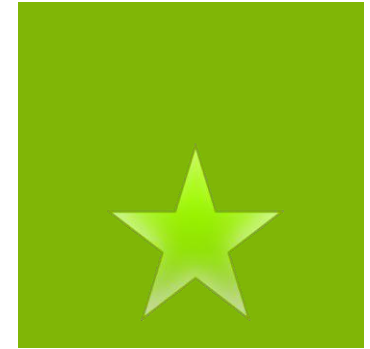

Incoterms 2010

- **EXW-Ex Works**
- **FCA-Free Carrier (named place)**
- **FAS-Free Alongside Ship (named port of shipment)**
- **FOB-Free On Board (name port of shipment)**
- **CFR-Cost & Freight (named port of destination)**
- **CIF-Cost, Insurance & Freight (named port of destination)**
- **CPT-Carriage Paid To (named port of destination)**
- **CIP-Carriage, Insurance Paid To (port of destination)**
- **DAP-Delivered at Place (named place)**
- **DAT-Delivered at Terminal (named place or terminal)**
- **DDP-Delivered Duty Paid (named place of destination)**

Required Documents

- Proforma Invoice

- Commercial Invoice

- DESTINATION CONTROL STATEMENT:

“ THESE COMMODITIES, TECHNOLOGY OR SOFTWARE WERE EXPORTED FROM THE UNITED STATES IN ACCORDANCE WITH THE EXPORT ADMINISTRATION REGULATIONS. DIVERSION CONTRARY TO U.S. LAW PROHIBITED.”



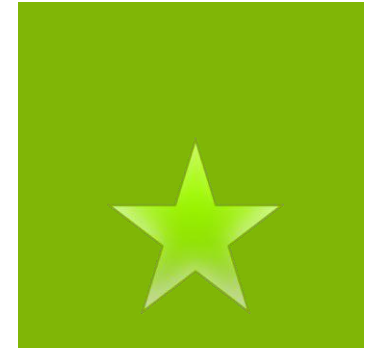

Required Documents

- **Packing List**
- **Bill of Lading**
 - Contract between the owner of the goods and the carrier
Serves as: #1 receipt of cargo #2 contract of carriage
#3 title of goods
 - Types:
 - Air waybill – non-negotiable document
 - Ocean bill of lading – negotiable document
 - Truck bill of lading – non-negotiable document
- **Certificate of Origin**
- **Shipper's Letter of Instructions**



You could see these too..



- ISMP15 stamp-treated wood packing
- FWS 3177 CITES permit for export
- BIS License
- Inland Bill of Lading
- Consular Invoice
- Insurance
- Documents specific to your item



■ POA required from your BFF



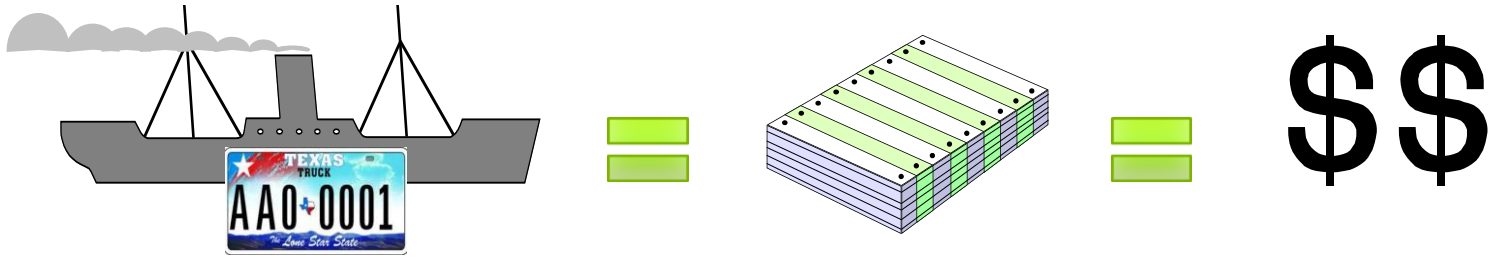



Filing the EEI with the AES

The 1 Rule for EEI

- ◆ ONE USPPI shipping their merchandise, to
- ◆ ONE foreign consignee, on
- ◆ ONE carrier moving the product out of the U.S., on
- ◆ ONE day,
- ◆ Valued at over \$2,500 per Schedule B number or when a license is required



ATA Carnets

- Valid for a year, the Carnet allows duty-free entry of goods into a country for:
 - Promotional merchandise
 - Show samples (not to be sold or given away)
 - Temporary use equipment

Be careful! Goods sold while under a Carnet must be filed as an entry.



Insurance Anyone?



**Ask me about
general
averaging?**



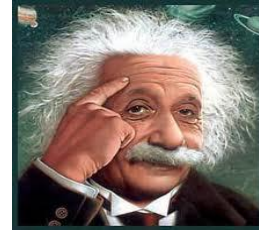

Skill

- What are the key points of this session?
- Name the acronyms or terms that are important to take away.
- What are the key questions to ask?
- What are the next steps?
- What are the red flags to watch out for?
- Any great tidbit of information?



Sources

- <http://www.americanshipper.com>
- www.worldportsource.com/index.php
- www.oceanschedules.com/schedules/search.d
- www.onlineconversion.com
- www.forwarders.com
- Kurt Mann, American Shipping, Irving, TX