

THE TESLA COIL

Christopher Gerekos,
2nd year Physics undergraduate student.

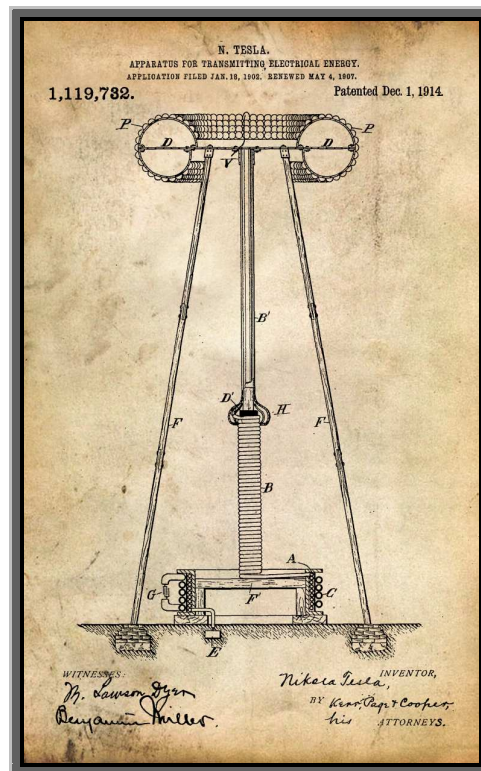

*"Let the future tell the truth and evaluate each one according to his work and accomplishments.
The present is theirs; the future, for which I really worked, is mine."*

-Nikola Tesla

Special thanks

This Tesla coil never would have existed without my friend Mael Flament, former student at the Université Libre de Bruxelles, now studying at the Hawaii University (Manoa). He initiated the idea of this project and taught me the basics of electrical engineering and crafting.

I also thank Kevin Wilson, creator of the *TeslaMap* program and webmaster of *Tesla Coil Design, Construction and Operation Guide*ⁱ, which were my main guides during the early stages of the conception and construction of the coil. He also proofread this English version of the present document.

Thanks to Thomas Vandermergel for his participation in the *Printemps des Sciences* fair and to Jean-Louis Colot for his guidance and his awesome photographs of Zeus.

I also express my full gratitude to my family for their support.

ⁱReferenced in the [Bibliography](#).

Contents

1	Introduction	1
2	The Zeus Project	3
3	Theory of operation	5
3.1	Reminder of the basics	5
3.1.1	Resistor	5
3.1.2	Capacitor	6
3.1.3	Inductor	6
3.1.4	Impedance	7
3.2	LC circuit	8
3.2.1	Impedance	12
3.2.2	Resonant frequency	13
3.2.3	RLC circuit	13
3.3	Tesla coil operation	15
3.3.1	Description of a cycle	15
3.3.2	Voltage gain	19
3.3.3	Comparison with the induction transformer	20
3.3.4	Distribution of capacitance within the secondary circuit	21
3.3.5	Influence of the coupling	22
3.3.6	A few words on the three-coil transmitter	23
3.4	The quarter-wave antenna	24
3.4.1	Comparison with the Tesla coil	24
4	Conception and construction	26
4.1	HV transformer	26
4.1.1	Arc length	28
4.2	Primary circuit	29
4.2.1	Capacitor	29
4.2.2	Charge at resonance	36
4.2.3	Inductance	38
4.3	Spark gap	42
4.4	Secondary circuit	45
4.4.1	Coil	45
4.4.2	Top load	48
4.5	Resonance tuning	51
4.6	RF ground	52
4.7	Other components	53

4.7.1	NST protection filter	53
4.7.2	PFC capacitor	54
4.7.3	AC line filter	56
4.8	Last step	56
5	Nikola Tesla, a mind ahead of its time.	57
	Appendices	59
A	Specifications of the Zeus Tesla coil	60
B	Behavior of the signal in the secondary coil	63
C	Analysis of the RLC circuit	65
D	Analysis of two inductively coupled oscillating circuits.	67
D.1	Two coupled LC circuits	67
D.2	Two coupled RLC circuits	70
	References	75
	Bibliography	76

Chapter 1

Introduction

The device we now call a "Tesla coil" is probably the most famous invention of Nikola Tesla. On the patent he submitted in 1914 to the *US Patent & Trademark Office*, it was called "Appartus for transmitting electrical energy"ⁱ

Nikola Tesla was born the 10th of July 1856 in a Serbian village of the Austrian Empire (in today's Croatia) and died the 7th of January 1943 in the United States [1].

It is not an exaggeration to say he was a visionary who changed the world. With his works on alternative current, including many patents on generators, transformers and turbines, he allowed the widespread proliferation of electricity as a source of power as we know it today.

He was also a pioneer in the domain of telecommunications ; the Tesla coil can be viewed as one of the very first attempts of a radio antenna. It consisted of circuits that are fundamentally the same as our modern wireless devices.

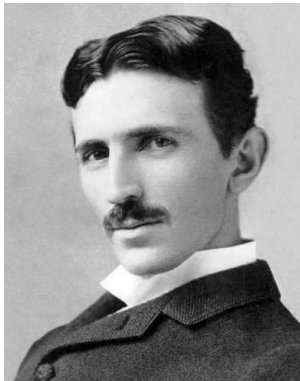

Figure 1.1: Nikola Tesla in 1890.

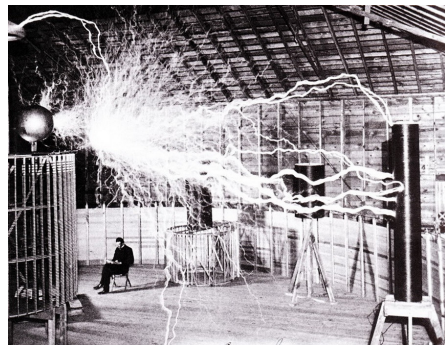

Figure 1.2: His first laboratory in Colorado Springs.
[Photographs : Wikimedia Commons]

ⁱThe front picture is a drawing associated with this patent. See [Bibliography](#).

Document structure

This document is about the theory of operation of Tesla coils as well as the specific behavior of its individual components. It also relates the steps of the construction of my own first coil, Zeus.

We will only discuss the conventional Tesla coil, consisting of a spark gap and two tank circuits and called *Spark Gap Tesla Coil* (SGTC). In fact, Nikola Tesla also conceived a more advanced type of coil, the magnifying transmitter, which is made of three coils instead of two and which operates in a slightly more complicated manor. In addition, there is also a class of semiconductors-controlled Tesla coils called Solid State Tesla Coils (SSTC), which are structurally different but share the same theoretical basis of the conventional Tesla coil.

To fully appreciate this document, it is recommended that you master the fundamental concepts of electromagnetism and alternating currentⁱⁱ, as well as the basics of differential equations.

ⁱⁱ*All About Circuits* (<http://www.allaboutcircuits.com>) is an excellent on-line resource. Volumes I and II largely span the "engineering" part of the aforementioned perquisites.

Chapter 2

The Zeus Project

This Tesla coil was presented to the *Printemps des Sciences 2012* science fair and is now at the *Expérimentarium de Physique* science museum at ULB. It was named **Zeus** (Ζεός in ancient Greek or Δίας in modern Greek) ; in honor of the Greek god, king of the Olympians and known for throwing lightning bolts.

It has a power of 225 W, which is quite low compared to the coils built by professionals, which often surpass several thousands of Watts. It is nevertheless an appreciable power, given the small budget that was allocated.



Figure 2.1: The Zeus Coil.

The construction of Zeus was not an easy task and almost every component had to be rebuilt at least twice. This however allowed me to acquire my first experience in the domain of high voltages, which was probably the greatest reward this project gave me.

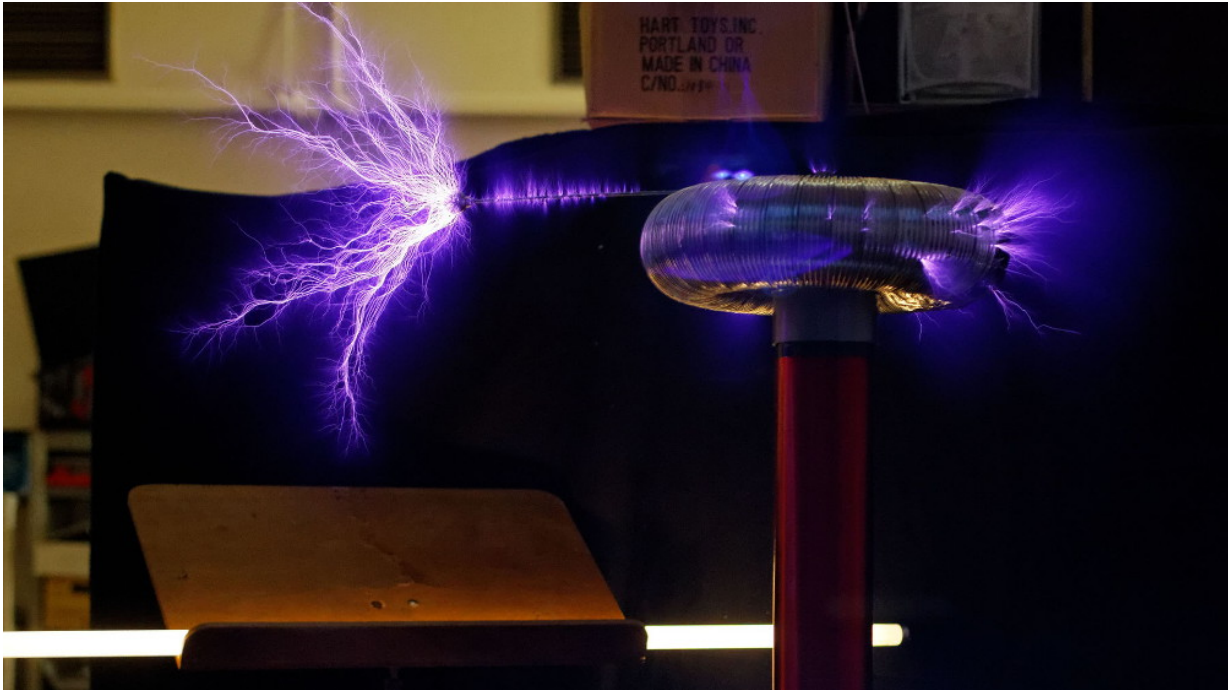

Figure 2.2: Cool beautiful arcs. 1s shutter speed [Photographs: Jean-Louis Colot].

Chapter 3

Theory of operation

In this chapter, we will discuss the theory of operation of Tesla coils in a general way. For the moment, let us introduce this short definition:

A Tesla coil is a device producing a high frequency current, at a very high voltage but of relatively small intensity.

Basically, it works as a transformer and as a radio antenna, even if it differs radically from these.

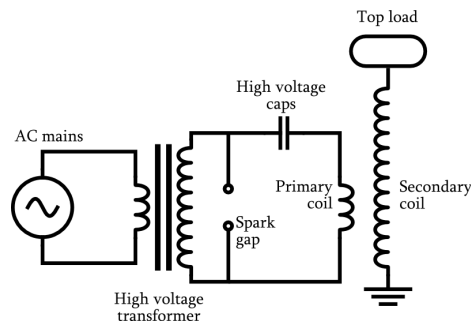

Figure 3.1: Basic electric schematic of a Tesla coil. [Schematic : Wikipedia]

3.1 Reminder of the basics

3.1.1 Resistor

A resistor is a component that opposes a flowing current.

Every conductor has a certain resistanceⁱ If one applies a potential difference V at the terminals of a resistor, the current I passing through it is given by

$$I = \frac{V}{R}$$

(3.1) Figure 3.2: Symbol of a resistor.



This formula is known as *Ohm's Law*ⁱⁱ. The SI unit of resistance is the Ohm, $[\Omega]$.

ⁱExcept superconductors, which have a strictly zero resistance.

ⁱⁱGeorg Simon Ohm : German physicist, 1789-1854.

One can show that the power P (in J/s) dissipated due to a resistance is equal to

$$P = VI = RI^2 \quad (3.2)$$

3.1.2 Capacitor

A capacitor is a component that can store energy in the form of an electric field.

Less abstractly, it is composed in its most basic form of two electrodes separated by a dielectric medium. If there is a potential difference V between those two electrodes, charges will accumulate on those electrodes: a charge Q on the positive electrode and an opposite charge $-Q$ on the negative one. An electrical field therefore arises between them. If both of the electrodes carry the same amount of charge, one can write

$$Q = CV \quad (3.3)$$

where C is the *capacity* of the capacitor. Its unit is the Faradⁱⁱⁱ [F].

The energy E stored in a capacitor (in Joules) is given by

$$E = \frac{1}{2}QV = \frac{1}{2}CV^2 \quad (3.4)$$

where one can note that the dependence in the charge Q shows that the energy is indeed the energy of the electric field. This corresponds to the amount of work that has to be done to place the charges on the electrodes.

3.1.3 Inductor

An inductor stores the energy in the form of a magnetic field.

Every electrical circuit is characterized by a certain inductance. When current flows within a circuit, it generates a magnetic field \mathbf{B} that can be calculated from Maxwell-Ampère's law^{iv}:

$$\nabla \times \mathbf{B} = \mu_0 \mathbf{J} + \mu_0 \varepsilon_0 \frac{\partial \mathbf{E}}{\partial t} \quad (3.5)$$

where \mathbf{E} is the electric field and \mathbf{J} is the current density. The *auto-inductance* of a circuit measures its tendency to oppose a change in current: when the current changes, the flux of magnetic field Φ_B that crosses the circuit changes. That leads to the apparition of an "electromotive force"^v \mathcal{E} that opposes this change. It is given by

$$\mathcal{E} = -\frac{\partial \Phi_B}{\partial t} \quad (3.6)$$

The inductance L of a circuit is thus defined as:

$$V = L \frac{\partial I}{\partial t} \quad (3.7)$$

ⁱⁱⁱMichael Faraday: British physicist and chemist, 1791-1867.

^{iv}James Clerk Maxwell, Scottish physicist and mathematician, 1831-1879. André-Marie Ampère, French physicist and mathematician, 1755-1836.

^vThis is not properly a force, as the units of \mathcal{E} are Volts. The point is that we cannot talk of a potential difference between two points, as the current flows without a material voltage generator.



Figure 3.3: Symbol of a capacitor.



Figure 3.4: Symbol of an inductor

where $I(t)$ is the current that flows in the circuit and V the electromotive force (emf) that a change of this current will provoke. The inductance is measured in henrys^{vi} [H].

The energy E (in Joules) stored in an inductor is given by

$$E = \frac{1}{2}LI^2 \quad (3.8)$$

where the dependence in the current I shows that this energy originates from the magnetic field. It corresponds to the work that has to be done against the emf to establish the current in the circuit.

3.1.4 Impedance

The impedance of a component expresses its resistance to an alternating current (i.e. sinusoidal). This quantity generalizes the notion of resistance. Indeed, when dealing with alternating current, a component can act both on the amplitude and the phase of the signal.

Expressions for alternating current

It is convenient to use the complex plan to represent the impedance. The switching between the two representations is accomplished by using Euler's formula. Let's note that the utilization of complex numbers is a simple mathematical trick, as it is understood that only the real part of these quantities is meaningful. We are now given an expression of the general form of the voltage $V(t)$ and current $I(t)$:

$$V(t) = V_0 \cdot \cos(\omega t + \phi_V) \quad \Leftrightarrow \quad V(t) = V_0 \cdot \operatorname{Re} \left\{ e^{j(\omega t - \phi_V)} \right\} \quad (3.9)$$

$$I(t) = I_0 \cdot \cos(\omega t + \phi_I) \quad \Leftrightarrow \quad I(t) = I_0 \cdot \operatorname{Re} \left\{ e^{j(\omega t - \phi_I)} \right\} \quad (3.10)$$

where V_0 and I_0 are the respective amplitudes, $\omega = 2\pi\nu$ is the angular speed (assumed identical for both quantities) and ϕ are the phases.

Definition of impedance

The impedance, generally noted Z , is formed of a real part, the resistance R , and an imaginary part, the reactance X :

$$Z = R + jX \quad (\text{cartesian form}) \quad (3.11)$$

$$= |Z|e^{j\theta} \quad (\text{polar form}) \quad (3.12)$$

where j is the imaginary unit number, i.e. $j^2 = -1$, $\theta = \arctan(X/R)$ is the phase difference between voltage and current, and $|Z| = \sqrt{R^2 + X^2}$ is the euclidean norm of Z in the complex plane.

At this point, we can generalize Ohm's law as the following :

$$V(t) = Z \cdot I(t) \quad (3.13)$$

When the component only acts on the amplitude, in other words when $X = 0$, the imaginary part vanishes and we find $Z = R$. We therefore have the behavior of a resistor. The component is then said to be *purely resistive*, and the DC version of Ohm's law (3.1) applies.

When the component only acts on the phase of the signal, that is when $R = 0$, the impedance is purely imaginary. This translates the behavior of "perfect" capacitors and inductors.

^{vi}Joseph Henry, American physicist, 1797-1878.

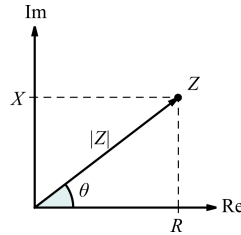

Figure 3.5: The impedance Z plotted in the complex plane. [Diagram : Wikipedia]

Impedance formulas

We can give a general formula for the impedance of each type of component.

Component	Impedance	Effect on an alternating signal
Resistor	$Z = R$	Diminution of amplitude (current and tension).
Capacitor	$Z = \frac{1}{jC\omega}$	Tension has a $\pi/2$ delay over current.
Inductor	$Z = jL\omega$	Current has a $\pi/2$ delay over tension.

These formulas are easily recovered from the differential expressions of these components. For every combinations of components, one can calculate the phase difference between current and voltage by vector-adding the impedances (for example, in an RC circuit, the phase difference will be less than $\pi/2$).

Finally, it is good to keep in mind that any real-life component has a non-zero resistance and reactance. Even the simplest circuit, a wire connected to a generator has a capacitance, an inductance and a resistance, however small these might be.

3.2 LC circuit

An LC circuit is formed with a capacitor C and an inductor L connected in parallel or in series to a sinusoidal signal generator. The understanding of this circuit is at the very basis of the Tesla coil functioning, hence the following analysis.

The primary and secondary circuits of a Tesla coil are both series LC circuits^{vii} that are magnetically coupled to a certain degree. We will therefore only look at the case of the series LC circuit.

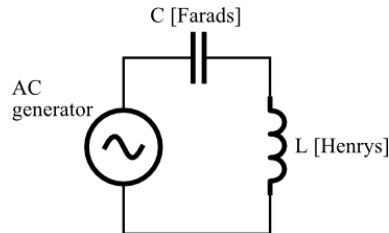

Figure 3.6: Schematic of a series LC circuit.

Using Kirchoff's law for current, we obtain that the current in the inductor and the current in the capacitor is identical. We now use Kirchoff's law for voltage, which states that the sum of the voltages

^{vii}Of course, they're actually RLC circuits, which, we'll talk about later, as all the components and wires have a certain resistance. However, materials used as well as the section of the conductors keep this resistance negligible. We can therefore consider in first approximation that the real circuits behave like LC circuits.

across the components along a closed loop is zero, to get the following equation :

$$V_{gen}(t) = V_L(t) + V_C(t) \quad (3.14)$$

For the inductor, we use the equality (3.7) and express the time derivative of current in terms of the charge by $I = \frac{dQ}{dt}$. We find

$$V_L(t) = L \frac{dI}{dt} \quad (3.15)$$

$$= L \frac{d^2Q}{dt^2} \quad (3.16)$$

Now for the capacitor, we isolate the charge Q in the relation (3.3) and get

$$V_C(t) = \frac{1}{C}Q(t) \quad (3.17)$$

Plugging these two results in (3.14), we obtain :

$$\boxed{V_{gen}(t) = L\ddot{Q} + \frac{1}{C}Q} \quad (3.18)$$

This equation describes an (undamped) harmonic oscillator with periodic driving, just like a spring-mass system! The inductor is assimilated to the "mass" of the oscillator : a circuit of great inductance will have a lot of "inertia". The "spring constant" is associated with the inverse of the capacitance C^{-1} (this is the reason why C^{-1} is seldom called the "elastance").

Homogeneous solution

The homogeneous equation, i.e. without independent term (representing the generator, in this case) is the following :

$$L\ddot{Q} + \frac{1}{C}Q = 0 \quad (3.19)$$

This equation corresponds to a real situation: the capacitor holds a certain charge and we let the system evolve freely. The mechanical analogy with the spring-mass system correspond to an initial state where the spring is tense and when no other force interacts^{viii}

We find the solution to equation (3.19) with the characteristic polynomial method. We obtain a sum of complex exponentials, which is of course an oscillating solution as expected.

$$Q(t) = K_1 e^{j\omega t} + K_2 e^{-j\omega t} \quad (3.20)$$

where we noted $\omega \equiv 1/\sqrt{LC}$.

Setting $Q(0) \equiv Q_0$ and $\dot{Q}(0) = I(0) \equiv 0$, which indeed corresponds to the initial condition where the capacitor is fully loaded and no current initially flows in the inductor, we get

$$\frac{K_1}{2} = Q_0 = \frac{K_2}{2} \quad (3.21)$$

We now take the real part of $Q(t)$, but thanks to (3.21), the solution is already real :

$$\boxed{Q(t) = Q_0 \cos(\omega t) = Q_0 \cos\left(\frac{t}{\sqrt{LC}}\right)} \quad (3.22)$$

^{viii}Equation (3.19) has of course the trivial solution $Q(t) = 0 \forall t$, but we won't consider it here.

We now find the current flows through the inductor by time-derivating the above expression for the charge stored in the capacitor :

$$I(t) = -\frac{Q_0}{\sqrt{LC}} \sin\left(\frac{t}{\sqrt{LC}}\right) \quad (3.23)$$

The next figures give a good intuition of what actually happens in the circuit. We look at the voltage $V(t)$ between the leads of the capacitor as well as the current $I(t)$ running into the inductor (which is the same in the entire circuit, as previously stated). For convenience, we put all the constants Q_0 , L , and C to unity.

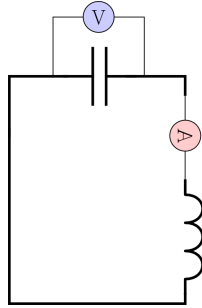

Figure 3.7: LC circuits with voltmeter and ammeter

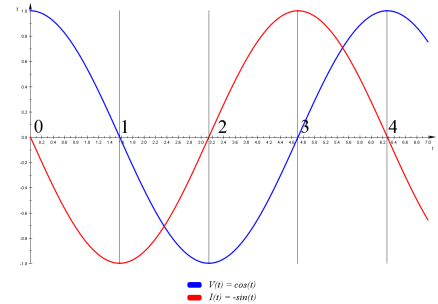

Figure 3.8: Plot of tension in current versus time.

Step 0: At the initial instant, the capacitor is fully charged and no current flows. Immediately after, the capacitor begins to discharge: the voltage decreases as a current gradually appears in the circuit.

Step 1: When the capacitor is totally discharged, the voltages at its leads is zero. If there was no inductance, things would stop right here. However, the inductor opposes this brutal drop of current by generating an electromotive force that will keep the current going^{ix}. In this way, the current gradually decreases (instead of stopping abruptly) and recharges the capacitor on the way (with an opposite polarity).

Step 2: The capacitor is fully charged again, with opposite polarity now, and the current has fallen to zero. However the charges stored in the capacitor are wanting to neutralize themselves^x : a current will reappear while the voltage is decreasing again.

Step 3: The capacitor is "empty" again (zero voltage), but the inductor prevents the current from stopping abruptly. This current will now recharge the capacitor with reversed polarity ...

Step 4: ... and the situation is exactly like it was at the initial instant.

We have already noted at this point that the system naturally oscillates at a certain *resonant* angular speed $\omega = \frac{1}{\sqrt{LC}}$, which is univoquely determined by the inductance and the capacitance of the circuit.

^{ix}Let us remember the mechanical analogy :inductance gives "inertia" to the circuits.

^xJust like a tense spring wants to recover its neutral shape.

General solution.

We reconsider equation (3.18) with its independent term, where we explicitly state the fact that the generator produces a sinusoidal voltage of amplitude, say, V_0 and of pulsation Ω :

$$L\ddot{Q} + \frac{1}{C}Q = V_0 \sin(\Omega t) \quad (3.24)$$

We will find a specific solution to obtain the general solution

If $\omega \neq \Omega$. We make an educated guess about a specific solution Q_p by stating it has the following form: $Q_p = A \sin(\Omega t - \varphi)$, with amplitude A and phase φ to be determined. We derivate this guessed solution twice and inject it straight into our starting equation (3.24) :

$$A \left[\frac{1}{C} - \Omega^2 L \right] \sin(\Omega t - \varphi) = V_0 \sin(\Omega t) \quad (3.25)$$

Equating amplitude and phase into the two parts of this equality, we deduce :

$$\begin{cases} A = \frac{V_0}{1/C - \Omega^2 L} = \frac{V_0}{L(\omega^2 - \Omega^2)} \\ \varphi = 0 \end{cases} \quad (3.26)$$

The specific solution is therefore :

$$Q_p(t) = \frac{V_0}{L(\omega^2 - \Omega^2)} \sin(\Omega t) \quad (3.27)$$

We can now find the general solution by adding the specific solution to the homogeneous solution (3.20).

$$Q(t) = \tilde{K}_1 \cos(\omega t) + \tilde{K}_2 \sin(\omega t) + \frac{V_0}{L(\omega^2 - \Omega^2)} \sin(\Omega t) \quad (3.28)$$

The current is :

$$I(t) = \omega \tilde{K}_2 \cos(\omega t) - \omega \tilde{K}_1 \sin(\omega t) + \frac{V_0 \Omega}{L(\omega^2 - \Omega^2)} \cos(\Omega t) \quad (3.29)$$

where the constants \tilde{K}_1 and \tilde{K}_2 can be found in terms of the initial conditions.

We see that we still have sinusoidal functions. If ω is close to Ω , the oscillations will be of great amplitude because of the "new" term, but will remain bounded. When ω is very far from Ω , the new term becomes negligible.

If $\omega = \Omega$. Here, the specific solution is more difficult to find. Let us rewrite (3.24) in a more convenient way :

$$\ddot{Q} + \omega^2 Q = \frac{V_0}{2Lj} (e^{j\omega t} - e^{-j\omega t}) \quad (3.30)$$

Here, we'll guess that the specific solution has the following form ; $Q_p(t) = (A_+ + B_+ t)e^{j\omega t} + (A_- + B_- t)e^{-j\omega t}$. This makes sense physically, as we expect the voltage and current to have amplitudes that increase with time. We rewrite it in a more condensed manner : $Q_p(t) = (A + Bt)e^{kt}$ with $k = \pm j\omega$. The second time-derivative yields $\ddot{Q}_p(t) = [k^2(A + Bt) + 2kB]e^{kt}$. We plug thses expression in (3.30) in order to refine them :

$$[(k^2 + \omega^2)(A + Bt) + 2kB]e^{kt} = \pm \frac{V_0}{2Lj} e^{kt} \quad (3.31)$$

We compare the two side of the equality as before.

When $k = j\omega$, we find

$$2j\omega B_+ e^{j\omega t} = \frac{V_0}{2Lj} e^{j\omega t} \quad (3.32)$$

$$B_+ = \frac{V_0}{4L\omega} \quad (3.33)$$

When $k = -j\omega$,

$$-2j\omega B_- e^{-j\omega t} = -\frac{V_0}{2Lj} e^{-j\omega t} \quad (3.34)$$

$$B_- = \frac{V_0}{4L\omega} \quad (3.35)$$

We have therefore found that $B_+ = B_- \equiv B$. And as we have found no constraints on the A 's, we set them equal to zero. We have now obtained our specific solution :

$$Q_p(t) = Bte^{j\omega t} + Bte^{-j\omega t} \quad (3.36)$$

$$= \frac{V_0 t}{4L\omega} (e^{j\omega t} + e^{-j\omega t}) \quad (3.37)$$

$$= \frac{V_0 t}{2L\omega} \cos(\omega t) \quad (3.38)$$

The general solution for the voltage is therefore :

$$\boxed{Q(t) = \tilde{K}_1 \cos(\omega t) + \tilde{K}_2 \sin(\omega t) + \frac{V_0 t}{2L\omega} \cos(\omega t)} \quad (3.39)$$

and the current is :

$$\boxed{I(t) = \left(\omega \tilde{K}_2 - \frac{V_0}{2L\omega} \right) \cos(\omega t) - \omega \tilde{K}_1 \sin(\omega t) - \frac{V_0 \omega t}{2L\omega} \sin(\omega t)} \quad (3.40)$$

where the constants \tilde{K}_1 and \tilde{K}_2 can be found in terms of the initial conditions.

In this case, we see we're no longer dealing with simple oscillations. The last term of the solution indicates that the amplitude of the voltage and current will increase at each cycle, and grow to infinity as $t \rightarrow \infty$.

3.2.1 Impedance

We'll have to calculate the impedance of the LC circuits inside the Tesla coil. Let us recall that the capacitor and the inductor are connected in series on the generator. The total impedance is therefore equal to the sum of the impedances of each component.

$$Z = Z_C + Z_L \quad (3.41)$$

$$= \frac{1}{jC\omega} + jL\omega \quad (3.42)$$

$$= j \frac{\omega^2 LC - 1}{\omega C} \quad (3.43)$$

We see that, at the resonant pulsation, $\omega^2 LC = 1$ and the impedance vanishes. A series LC circuit placed in series on a wire will therefore act as a *band-pass filter*. Similarly, a parallel LC circuit will act as a *band-stop filter* when connected in series on the wire [2]. There are many other possibilities for filters, but this is not within the scope of the present document.

3.2.2 Resonant frequency

In our analysis of the LC circuit, we found that the oscillations of current and voltage naturally occurred at a precise angular speed, univoquely determined by the capacitance and inductance of the circuit. Without other effects, oscillations of current and voltage will always take place at this angular speed.

$$\omega_{res} = \frac{1}{\sqrt{LC}} \quad (3.44)$$

It is called the *resonant angular speed*. We can check that it is dimensionally coherent (its units are s^{-1}).

It is however much more common to talk about *resonant frequency*, which is just a rescale of the angular speed :

$$f_{res} = \frac{1}{2\pi\sqrt{LC}} \quad (3.45)$$

It is no less important to observe that, at the resonant angular speed, the respective reactive parts of an inductor and a capacitor are equal (in absolute value) :

$$|X_L^{res}| = \frac{L}{\sqrt{LC}} = \frac{\sqrt{L}}{\sqrt{C}} = |X_C^{res}| \quad (3.46)$$

When there is a sinusoidal signal generator, we also saw that if its frequency is equal to the resonant frequency of the circuit it drives, current and voltage have ever-increasing amplitudes. Of course, this doesn't happen if they are different (the oscillation remain bounded).

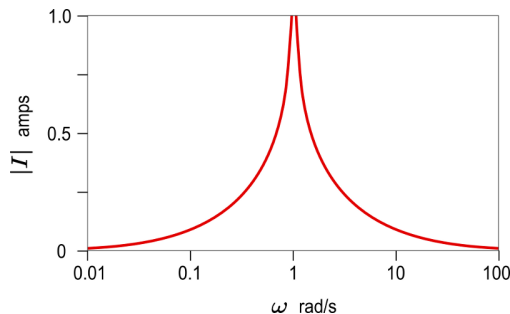

Figure 3.9: Amplitude of the current plotted against the driving frequency (all constants normalized). [Diagram : Wikipedia]

At low driving frequencies, the impedance is mainly capacitive as the reactance of a capacitor is greater at low frequencies. At high frequencies, the impedance is mainly inductive. At the resonant frequency, it vanishes, hence the asymptotic behavior of the current. However, in a real circuit, where resistance is non-zero, the width and height of the "spike" plotted here above are determined by the Q factor, which we'll talk about later.

The fact that driving an (R)LC circuit at its resonant frequency causes a dramatic increase of voltage and current is crucial for a Tesla coil. But it can also be potentially harmful for the transformer feeding the primary circuit. These practical considerations will be addressed in the next chapter.

3.2.3 RLC circuit

An RLC circuit is an LC circuit on which a resistance was added. This kind of circuit can take multiple forms. We won't analyze it here, but we'll give its major characteristics^{xi}.

^{xi}A thorough treatment is given in [Appendix C](#).

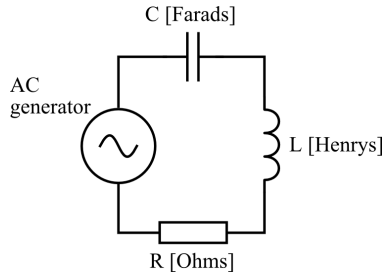

Figure 3.10: Schematic of a series RLC circuit.

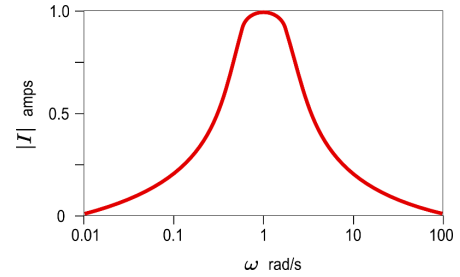

Figure 3.11: Amplitude of the current vs driving frequency for an RLC circuit (all constants normalized). [Diagram : Wikipedia]

The resistance ($V_R(t) = RQ'(t)$) dissipates the circuit's energy as heat, whatever the direction of the current. It therefore acts like a friction force. Without a generator, current and voltage will gradually decrease as they oscillate (the circuit is said to be *underdamped*) or, if the resistance is high enough, no oscillation will take place (*overdamped* circuit).

In the underdamped case, the graph of current or voltage is a sine wave whose amplitude decreases exponentially with time. If there is a driving force, the resistance will prevent the system from having oscillations of ever-increasing amplitude. And finally, instead of a spike, the RLC circuit has a *bandwidth*.

One can show that the resonant frequency of a RLC circuit is the same as the LC circuit [3][4]:

$$f_{res} = \frac{1}{2\pi\sqrt{LC}} \quad (3.47)$$

To find its impedance, we just have to add the value of the resistance R to (3.43). While the LC circuit had a purely imaginary impedance, the RLC circuit has a real part as well :

$$Z = R + j \left(\omega L - \frac{1}{\omega C} \right) \quad (3.48)$$

Q factor.

The Q factor (for *quality*) is a dimensionless quantity which characterizes every RLC circuit, or more generally, every damped oscillator. It measures the narrowness of the bandwidth : a large Q factor denotes a spiky bandwidth^{xii}.

More precisely, the Q factor represents the ratio between the energy stored in the circuit and the energy dissipated during the oscillations [5]. This can also be expressed in power terms [6] :

$$Q = \frac{P_{stored}}{P_{dissipated}} = \frac{XI^2}{RI^2} \quad (3.49)$$

$$= \frac{X}{R} \quad (3.50)$$

where X is the reactance of the inductor/capacitor at the resonant frequency.

For a RLC circuit, this becomes, using (3.45) :

$$Q = \frac{1}{R} \sqrt{\frac{L}{C}} \quad (3.51)$$

^{xii}In the stricter sense, the Q factor of a LC circuit is infinite, but the quantity is not really meaningful in this case.

One can also give a definition of the bandwidth Δf as a function of the Q factor [6] :

$$\Delta f = \frac{f_{res}}{Q} \quad (3.52)$$

It is then clear why this quantity is called the quality factor : an RLC circuit of "great quality" is strongly underdamped and will therefore dissipate very little energy per cycle [6]. Moreover, its bandwidth will be very narrow, which is desirable, for example, in a radio receiver.

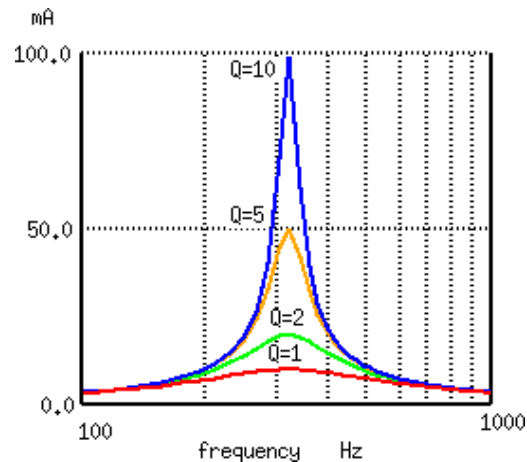

Figure 3.12: Effect of the Q factor on the bandwidth size. [Diagram : All About Circuits]

3.3 Tesla coil operation

This is where the fun begins.

This section shall cover the complete theory of operation of a conventional Tesla coil. We will consider that the primary and secondary circuits are RLC circuits with low resistance, which accords with reality^{xiii}.

We consider a slightly modified version of figure 3.1 to illustrate our explanations. For the aforementioned reasons, internal resistance of the component aren't represented. We will also replace the current-limited transformer. This has no impact regarding pure theory^{xiv}.

Note that some parts of the secondary circuit are drawn in dotted lines. This is because they are not *directly visible* on the apparatus. Regarding the secondary capacitor, we'll see that its capacity is actually distributed, the top load only being "one plate" of this capacitor. Regarding the secondary spark gap, it is shown in the schematic as a way to represent where the arcs will take place.

3.3.1 Description of a cycle

This is perhaps the most important section. In order to make it lighter, specific details of the individual components won't be discussed until Chapter 4.

^{xiii}A more rigorous analysis is given in [Appendix D](#).

^{xiv}Practical implications of the choice of the transformer/generator are discussed in the [next chapter](#).

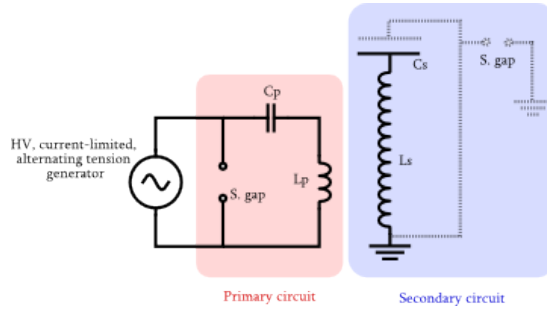

Figure 3.13: Schematic of the basic features of a Tesla coil.

Charging.

This first step of the cycle is the charging of the primary capacitor by the generator. We'll suppose its frequency to be 50 Hz.

Because the generator is current-limited, the capacity of the capacitor must be carefully chosen so it will be fully charged in exactly 1/100 seconds. Indeed, the voltage of the generator changes twice a period, and at the next cycle, it will re-charge the capacitor with opposite polarity, which changes absolutely nothing about the operation of the Tesla coil.

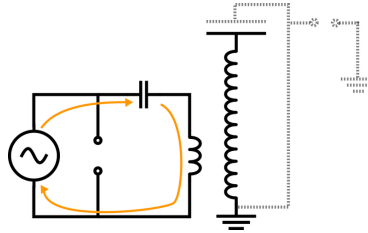

Figure 3.14: The generator charges the primary caps.

Oscillations.

When the capacitor is fully charged, the spark gap fires and therefore closes the primary circuit. Knowing the intensity of the breakdown electric field of air, the width of the spark gap must be set so that it fires exactly when the the voltage across the capacitor reaches its peak value. The role of the generator ends here ^{xv}.

We now have a fully loaded capacitor in an LC circuit! Current and voltage will thus oscillate at the circuits resonant frequency, as it was demonstrated in equations (3.22) and (3.23). This frequency is very high compared to the mains frequency, generally between 50 and 400 kHz ^{xvi}.

The primary and secondary circuits are magnetically coupled. The oscillations taking place in the primary will thus induce an electromotive force in the secondary. As the energy of the primary is dumped into the secondary, the amplitude of the oscillations in the primary will gradually decrease while those of the secondary will amplify. This energy transfer is done through magnetic induction. The coupling constant k between the two circuit is purposefully kept low, generally between 0.05 and 0.2[7]. Several

^{xv}The resistance of the spark gap is indeed negligible regarding the impedance of the transformers ballasts. The latter nevertheless is affected by what is happening in the primary circuit as we'll see it later, in section 4.7.1 NST protection filter.

^{xvi}We will calculate the resonant frequency of Zeus in section 4.6 Resonance settings.

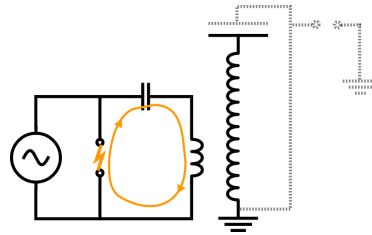

Figure 3.15: The spark gap fires, and the current oscillates in the primary circuit.

oscillations will therefore be required to transfer the totality of the energy. We will come back to the influence of coupling shortly.

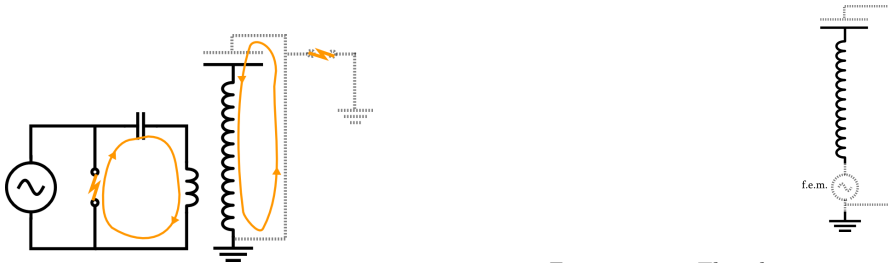

Figure 3.16: Oscillations in the primary will induce and emf in the secondary, which will also oscillate.

Figure 3.17: The electromotive force induced by the oscillations in the primary can be seen as an AC generator (whose amplitude depends on time) as shown here.

The oscillations in the primary will thus act a bit like an AC voltage generator placed in series on the secondary circuit [8]. To maximize the voltage in the secondary, it is intuitively clear that both circuits must share exactly the same resonant frequency^{xvii}.

$$\boxed{\frac{1}{2\pi\sqrt{L_p C_p}} = \frac{1}{2\pi\sqrt{L_s C_s}}} \tag{3.53}$$

This will allow the voltage in the secondary to increase dramatically, as we saw in equations (3.39) and (3.40). This is called the *resonant rise*. The voltage becoming rapidly enormous, generally several hundreds of thousand of volts, sparks will form at the top load.

The following diagrams show the general waveforms (in arbitrary units) of the oscillations taking place in the primary and secondary.

Bounces.

All the energy is now in the secondary circuit. With an ideal spark gap, things would stop here and a new cycle could begin. But this is of course not the case : the ringup is very fast and the path of ionized air subsists a few moments even when the intensity of the field has fallen below the critical value.

The energy of the secondary can therefore be retransmitted to the primary in a similar fashion. Current and voltage in the secondary will then diminish while those in the primary will increase.

Such bounces can occur 3, 4, 5 times or even more. At each rebound, a fraction of the energy is definitively lost, mainly in the sparks produced and in the internal resistances of the components^{xviii} [7].

^{xvii}The will be rigorously demonstrated in [Appendix D](#).

^{xviii}We will discuss losses in section [3.2.2 Voltage transformation](#).

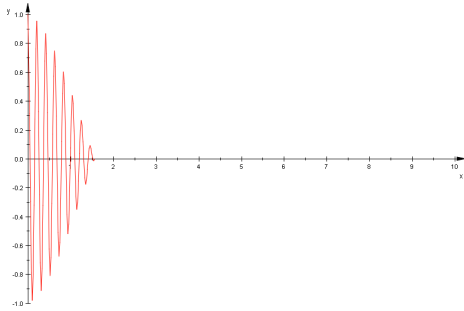

Figure 3.18: Oscillations of diminishing amplitude in the primary (ringdown).

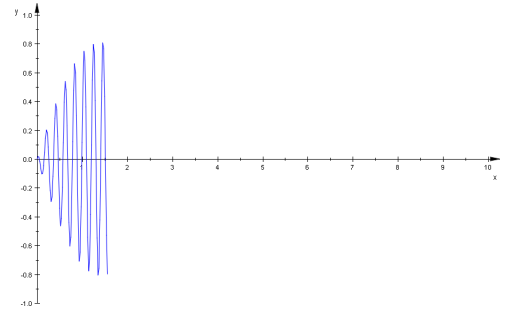

Figure 3.19: Oscillations of rising amplitude in the primary (ringup)

This is the reason why the envelop of the waveform falls exponentially. After a certain number of bounces, voltage will have decreased significantly and the spark gap finally opens at the next primary notch.

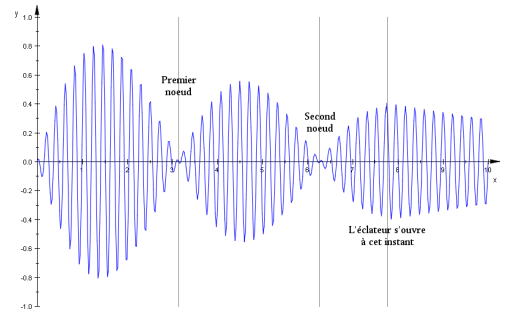
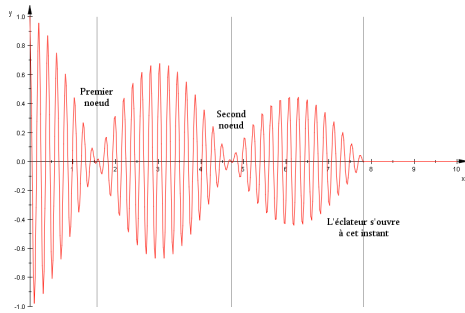

Figure 3.20: General waveform of the oscillation in the primary and secondary circuits. Here a cycle with 3 rebounds has been shown.

These rebounds are actually important for the creation of long arcs, because arcs grow on the ionized air path created during the previous rebounds. At each bounce, the spark gets longer. The complete process happens several hundred times per second. [7].

Decay.

Once the main spark gap has stopped firing, the primary circuit is open and all the remaining energy is trapped in the secondary. This situation is thus the same as in a free RLC circuit. Oscillations will decay exponentially as the charge dissipates through the sparks [7].

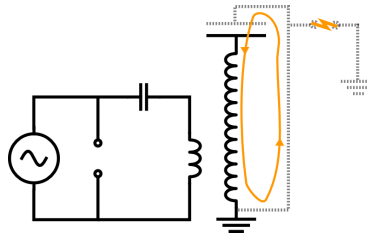

Figure 3.21: When the spark gap has opened, secondary oscillation will decay exponentially. Finally, a new cycle can begin.

3.3.2 Voltage gain

We will now derive a rough formula giving the secondary voltage V_{out} . We call V_{in} the rms voltage supplied by the transformer.

The following derivation is based on conservation of energy [7][8], we'll suppose there's no ohmic losses ($R = 0$) and that the primary and secondary circuits are perfectly at resonance.

Let's recall formula (3.4) giving the energy stored in a capacitor as a function of the voltage. The energy of the primary circuit E_p is thus given by

$$E_p = \frac{1}{2}C_p V_{in}^2. \quad (3.54)$$

where C_p is the capacity of the primary.

The energy E_s stored in the secondary circuit (capacity is C_s) is

$$E_s = \frac{1}{2}C_s V_{out}^2. \quad (3.55)$$

Using the hypothesis that all the energy stored in the primary goes into the secondary, we equate E_s and E_p :

$$\frac{1}{2}C_p V_{in}^2 = \frac{1}{2}C_s V_{out}^2 \quad (3.56)$$

The voltage gain is then:

$$\frac{V_{out}}{V_{in}} = \sqrt{\frac{C_p}{C_s}} \quad (3.57)$$

It is more convenient to express this gain in terms of the inductance of the circuits. Given the fact these are at resonance, we can see from (3.53) that

$$L_p C_p = L_s C_s. \quad (3.58)$$

The gain can therefore be rewritten this way:

$$\boxed{\frac{V_{out}}{V_{in}} = \sqrt{\frac{L_s}{L_p}}} \quad (3.59)$$

Now we can understand how the Tesla coil can reach such tremendous voltages : the secondary coil, which has around 1000 turns, has an inductance considerably higher than the primary coil, which generally has about 10 turns. Using typical values, this formula will yield a V_{out} of the order of 10^5 V or even 10^6 V for the largest coils.

Energy losses.

We supposed in the above derivation that energy losses are nonexistent. This is of course an approximation and the formula (3.59) is then a upper bound.

We'll describe here the major causes of these losses. These will be calculated/examined deeper in [chapter 4](#).

- The wiring and the inductances have an *internal resistance* that dissipates energy as heat following $P = RI^2$. There are several hundred meters of wire in a Tesla coil. The *skin effect*, which accounts for the fact that at higher frequencies, the current flows mainly near the surface of the conductors, further increases the effective resistance.

- The sparks that occur in the spark gap act like a resistor, dissipating energy in the form of light, heat and sound [7].
- The dielectric inside the primary capacitor dissipates a fraction of the energy when an alternating current is applied [9]. The loss tangent depends on the dielectric used and the frequency.
- The Tesla coil operates at radio frequencies (typically between 50 and 400 kHz^{xix}). A fraction of the energy is thus *radiated* as electromagnetic waves [7].
- The *Corona effect* is a continuous discharge from the conductors in the ambient medium, producing a violet halo around conductors kept at high voltages. The energy used for ionizing the air is taken away from the coil [7].

Let's finally note that primary and secondary circuits are rarely at perfect resonance, which contributes to a further reduction of the secondary voltage.

3.3.3 Comparison with the induction transformer

The Tesla coil operates in a significantly different manner than does the induction transformer (represented in Figures 3.22 and 3.23). Nevertheless the two apparatuses share interesting similarities, that is why we'll proceed through a quick comparison.

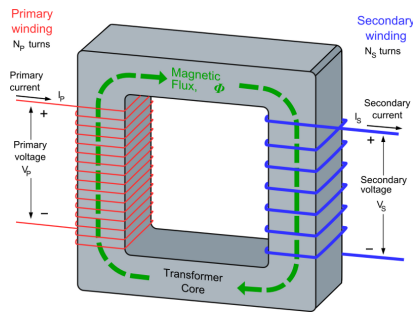

Figure 3.22: Schematic of a basic induction transformer (here a step-down). [Illustration : Wikipedia]



Figure 3.23: A real-life transformer. The wire of the primary is black, those of the secondary are green (the middle wire is the ground wire). [Photograph : Wikipedia]

In an induction transformer, the voltage and current are transformed by a pair of coils, also called primary and secondary, that are tightly wound around a core made of a highly permeable material. When alternating current arrives in the primary coil, an induced magnetic field appears, also alternating. This field will be considerably amplified by the core. As the secondary is also wound around this core, the aforementioned alternating magnetic field will induce an emf in the secondary. The latter provokes the apparition of a current, whose frequency is the same as the input current.

For this kind of transformer, one can show that:

$$\frac{V_{out}}{V_{in}} = \frac{L_s}{L_p} \quad (3.60)$$

The major difference with the Tesla coil is the absence of a capacitor in a induction transformer^{xx}. While the Tesla coils uses resonant amplification for increasing the voltage, the conventional transformer

^{xix}Roughly in the LF range.

^{xx}Capacitors can be found, in fact, in such transformers, for power factor correction for example, but these are not necessary for the transformation itself.

only uses magnetic induction. On the latter, primary and secondary coils have a very high coupling constant (as close to 1 as possible), while those of the Tesla coil share a coupling constant of much lower value, which can be directly seen in the disposition and shapes of the inductors and in the fact that they are air-cored. This explains why the gain in a conventional transformer is higher for given L_p and L_s (compare formulas (3.59) and (3.60))

This is however not by chance that both the devices rely on coils of different inductance to transform a current. The point in a Tesla coil is that $L_p C_p = L_s C_s$ must be achieved for efficient transformation

Finally, let's note the absence of cycles in the operation of a induction transformer : the current is transformed directly. Moreover, a conventional transformer works at the frequency of the input current^{xxi}, and the output current has the same frequency. But on a Tesla coil, the output current frequency is fixed.

3.3.4 Distribution of capacitance within the secondary circuit

We will now examine the question of the secondary capacitance which we called C_s in previous discussions. This capacitance consists of many contributions and is difficult to compute, but we'll look at its major components (see figure below).

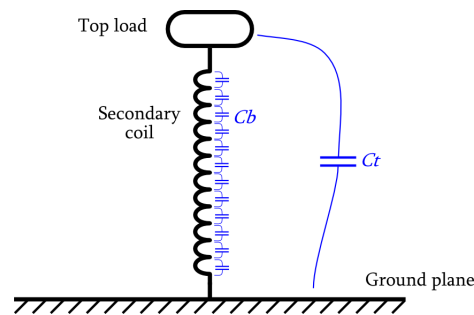

Figure 3.24: The major contributions to the secondary capacitance C_s .

Top load - Ground.

The highest fraction of the secondary capacitance comes from the top load [7][9]. Indeed we have a capacitor whose "plates" are the top load and the ground. It might be surprising that this is indeed a capacitor as these plates are connected though the secondary coil. However, its impedance is quite high so there's actually quite a potential difference between them.

We shall call C_t this contribution.

Turns of the secondary coil.

The other big contribution comes from the secondary coil [7][8]. It is made of many adjacent turns of enameled copper wire and its inductance is therefore distributed along its length. This implies there's a slight potential difference between two adjacent turns. We then have two conductors at different potential, separated by a dielectric : a capacitor, in other words. Actually, there is a capacitor with every *pair* of wires, but its capacity decreases with distance, therefore one can consider the capacity only between two adjacent turns a good approximation.

Let's call C_b the total capacity of the secondary coil.

^{xxi}Within a certain "reasonable" range of frequencies.

Actually, it's not mandatory to have a top load on a Tesla coil, as every secondary coil will possess its own capacity. We'll see however that a top load is crucial for having beautiful sparks ^{xxii} [7][13].

Other contributions.

When a spark occurs at the top load, it will add a little extra capacity to the secondary circuit [14]. This is most noticeable only on large coils however, whose spark are longer than a meter. This contribution will be negligible for our coil Zeus.

If the coil does not run on a verdant hill (which is often the case), there will be extra capacity form the surrounding objects. This capacitor is formed by the top load on one side and conducting objects (walls, plumbing pipes, furniture, etc.) on the other side.

Actually there's even more sources of capacity (for example these of the "top load - primary coil" capacitor), but these really become negligible.

We'll name the capacitor of these external factors C_e .

The whole thing...

As all these "capacitors" are in parallel, the total capacity of the secondary circuit will be given by :

$$C_s = C_t + C_b + C_e \quad (3.61)$$

Let's note that the reason why this capacity is so hard to define is because it is truly small (a few dozens of picoFarads). That's why all the factors must be taken in account. Indeed, they would also apply for the capacity of the primary circuit, but this one has a much greater capacity, which is totally concentrated in the primary capacitor, so the aforementioned factors are truly negligible.

3.3.5 Influence of the coupling

The constant of magnetic coupling k accounts for the fraction of the total field that the two coils are sharing. This constant is mainly determined by the relative position of the coil as well as their shape. ^{xxiii} [7]. We'll now see that this constant must be well-chosen.

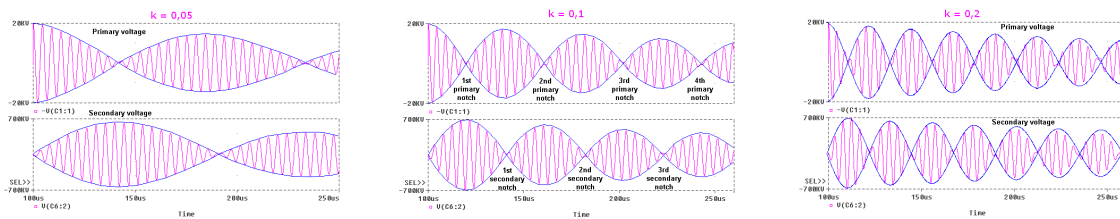

Figure 3.25: Waveforms of the primary and secondary voltage for increasing values of k . [Diagrams : Richard Burnett]

If the coupling is weak ($k \approx 0.05$), a significant number of oscillations will be required for all the energy to be transferred to the secondary. The primary notches are attained in a smoother way, which allows the spark gap to open more easily at the first notch, or at least at early ones. This is a good thing as the amplitude of the envelop is decreasing and so does the energy of the system. However, if the first notch is too far, a non-negligible fraction of energy will be lost.

^{xxii}More details in 4.4.2 Top load.

^{xxiii}See Appendix D.

If the coupling is stronger ($k \approx 0.2$), the number of oscillations required to transfer all the energy into the secondary will be lower. The rise of the voltage in the secondary coil is thus more brutal, which can cause arcs between the turns, a very bad thing. It will also be more difficult for the spark gap to open at the earliest notches (a powerful quenching system will be required). The advantage of strong coupling is that, if the aforementioned problems can be prevented, energy losses will be lower.

The ideal coupling is unique to each coil. Considering the above discussion, it is clear that high coupling constant will be preferable on coil of lower power. It's indeed unlikely that turn-shorting problems will occur as the overall voltages are lower. For the same reasons, a low coupling is recommended for high-power coils. It has also been suggested to avoid coupling between 0.43 and 0.53 [11].

3.3.6 A few words on the three-coil transmitter

At the beginning of this document, we mentioned an advanced version of the Tesla coil, which included three coils instead of two[10].

The primary circuit will remain roughly the same, the main differences appear in the secondary inductor. The latter is actually divided into two parts : the "proper" secondary coil, which has an unusually high coupling with the primary ($k \approx 0.6$) ; and an extra coil, the "magnifier", placed away from the magnetic field generated at the primary.

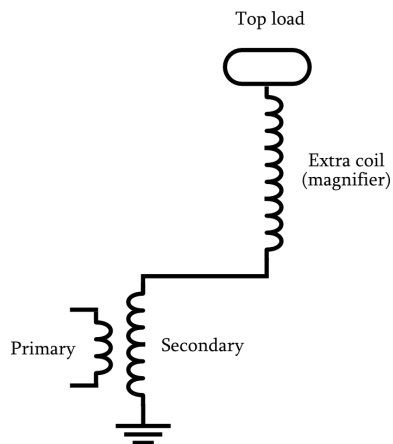

Figure 3.26: Configuration of the inductors on a magnifying transmitter

In this design, the voltage is first raised from the primary to the secondary coil by magnetic induction, in a similar fashion as in a conventional transformer. The voltage is then further augmented by the magnifier, using resonant amplification (the top load is at the end of this coil), just like an LC circuit amplifies the signal it receives when at resonance [10].

The idea here is to intensify the rise of the voltage by conceiving a more efficient way to use the emf generated in the secondary by the primary's magnetic field. This two-stage system can be seen as a hybrid between a classical Tesla coil and an induction transformer.

this configuration is however more difficult to realize as a strong coupling between the first stage of the secondary and the primary must be realized by ensuring no arcs will occur between the coils. The apparatus' behavior also seems to be more difficult to predict [12].

3.4 The quarter-wave antenna

When an alternating current flows in a conductor, it generates an oscillating electromagnetic field which propagates like a wave. These radio waves are the basis of all telecommunications.

It has been suggested that, by some aspects, a Tesla coil resembles a *quarter-wave antenna*. Actually, this model fails to describe the behavior of a the Tesla coil in a satisfying way [8]. It is moreover not necessary to tune the impedance of the coil like a quarter-wave antenna [9]. Nevertheless, the common traits of these two devices are interesting enough to justify this short exposition.

Let's begin with this quick definition : a quarter-wave antenna is an antenna whose length L is equal to $\lambda/4$, where λ is the wavelength of the input signal^{xxiv}.

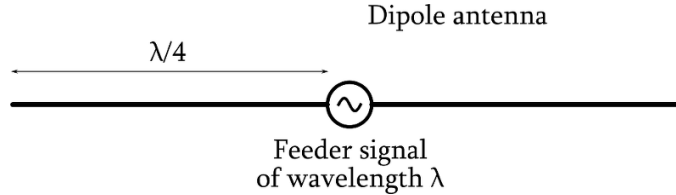

Figure 3.27: Basic schematic of a center-fed, dipole antenna, its length is $\lambda/2$. Each branch can be seen as a quarter-wave antenna.

3.4.1 Comparison with the Tesla coil

One can compare the secondary circuit to one of the branches of a dipole antenna, the other branch being the ground (about the theory governing transmission lines and antennas, refer to the outstanding reference [15]).



Figure 3.28: Analogy between a quarter-wave antenna and the secondary circuit of a Tesla coil.

When a wave of wavelength λ reaches the extremity of the antenna, it will be totally reflected. One can show that if the length of the antenna (which would correspond to the length of the wire used in the secondary winding of the Tesla coil) is an integer multiple of $\lambda/4$, this reflexion will cause *stationary waves* to appear[15] [16]. In other words, its length L must be

$$L = n \frac{\lambda}{4} \quad n = 1, 2, 3, \dots \quad (3.62)$$

On a quarter-wave, n is equal to 1 (see Figure 3.29-left). Let's examine the nature of the stationary wave for the current $I(x, t)$ and voltage $E(x, t)$. One can show that if n is *odd*, then there will be a voltage node at the beginning of the antenna and a voltage antinode at its extremity. For the current, there will be an antinode at the base of the antenna and a node at its extremity. In other words,

$$\begin{aligned} E(0, t) &= 0 \\ E(L, t) &= E_0 \cos \omega t \end{aligned}$$

^{xxiv}Voltage as well as current are alternating signals, defining a wavelength thus makes sense.

and

$$I(0, t) = I_0 \cos \omega t$$

$$I(L, t) = 0$$

where E_0 and I_0 denote the maximal amplitude of the wave, and $\omega = \lambda/c$, where c is the speed of propagation of electromagnetic waves (about $3 \cdot 10^8 \text{ ms}^{-1}$). We've chosen the origin of times so there is no phase.

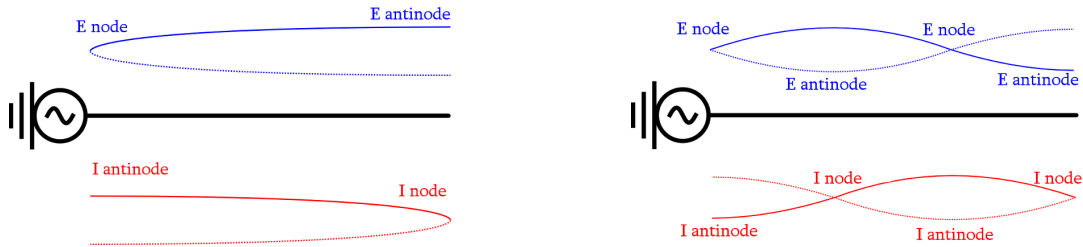

Figure 3.29: Behavior of the voltage $E(x, t)$ and current $I(x, t)$ on an antenna of length $\lambda/4$ (left) and $3\lambda/4$ (right). [Schematics: Adapted from All About Circuits]

We can thus easily understand the benefits that we could, theoretically, have by tuning a Tesla coil following the quarter-wave antenna model, i.e. choosing the length of the secondary wire such as it is one quarter of the wavelength at resonant frequency. This would indeed ensure there is an antinode of voltage at the top of the coil, which is what we want.

However, it has been experimentally demonstrated that the currents at the base and at the top of the coil are actually almost in phase. This shows the quarter-wave antenna model doesn't apply for the Tesla coil and that one can consider its capacitance and inductance to be lumped [17].

Chapter 4

Conception and construction

This chapter deals with the formulas used to conceive the Zeus Tesla coil and also with specific details of practical scope.

To consult the data of the JAVATC simulation (program written by Bart Anderson, see [Bibliography](#)), refer to [Appendix A](#).

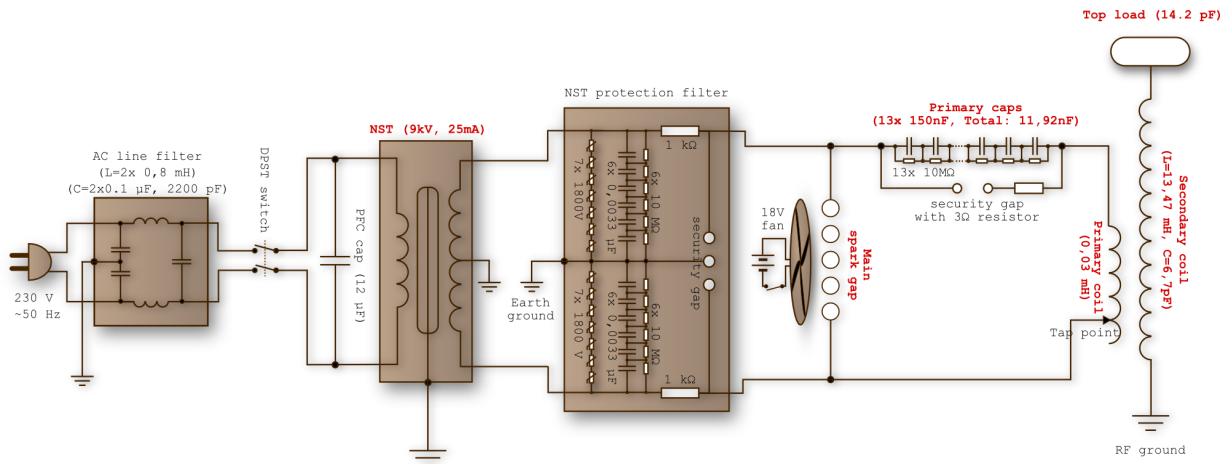

Figure 4.1: Complete electrical schematic of Zeus. Core components are in red.

4.1 HV transformer

The high voltage transformer is the most important part of a Tesla coil. It is simply an induction transformer. Its role is to charge the primary capacitor at the beginning of each cycle. Apart from its power, its ruggedness is very important as it must withstand terrific operation conditions (a protection filter is sometimes necessary, see [4.7.1 NST protection filter](#)).

Among the most common are the *pole pigs*, normally used in the electrical grid. These typically provide around 20kV and have no integrated current limitationⁱ, which makes them quite deadly if not handled correctly. Obtaining one is quite difficult in Europe.

ⁱLarge ballasts inductors are required to limit the current.

The other widely-used type of transformer is the *neon sign transformer* (NST), which is, as its name suggests, generally used to power neon signs. They generally supply between 6 and 15 kV and are current-limited often at 30 or 60 mA. They are safer and easier to find than the pole pigs but are more fragile. Notice that newer NST should be avoided, as they are provided with a built-in differential circuit breaker, which will prevent any Tesla coil operation. Indeed, we'll later see that this provokes repeated spikes of current and voltages that will trigger the breaker.

Beside from these two common types, one can also use a flyback transformer or a microwave oven transformer (MOT)

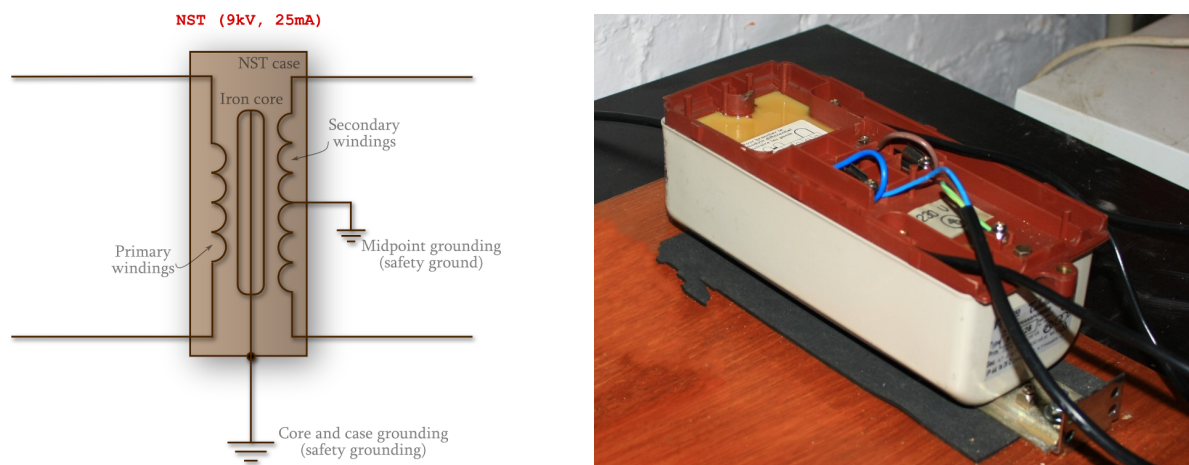

Figure 4.2: Schematic and photograph of Zeus' NST (out of his wooden box).

The power supply of Zeus consists of a single NST, whose characteristics (rms values) are the following :

$Voltage = 9000 \text{ V}$ $Current = 25 \text{ mA}$

We can now compute its power $P = VI$, which will be useful to set the global dimensions of the Tesla coil as well as a rough idea of its sparks' length.

$$P = 225 \text{ W}$$

Zeus has thus a relatively low power, which is perhaps not a bad thing for a very first coil. For more power, one can connect several transformers in parallel in order to increase output current.

We'll also need to know the transformer's impedance in order to compute the optimal size of the primary capacitor. Using Ohm's law $Z = V/I$, one finds :

$$Z = 360 \text{ k}\Omega$$

4.1.1 Arc length

There's an empirical formula giving the maximal length of the sparks only from the output power of the transformer. For the reasons mentioned in chapter 3, paragraph [Energy losses](#), it's very difficult to reach this value ⁱⁱ.

The phenomenon of gas breakdown is extremely complex, and the arc length depends on much more than simply the voltage at the top load ⁱⁱⁱ.

The basic formula giving the length L of the sparks in centimeters is the following [19] :

$$L \approx 4.32\sqrt{P_{in}}$$

where P_{in} is the power output of the transformer in watts. We apply the formula to Zeus (225 W) :

$$L \approx 65 \text{ cm} \tag{4.1}$$

There are however more precise formulas, which notably take into account the Q factor of the secondary coil and the firing frequency of the spark gap [19]. The JAVATC simulation gave the value of 55 cm.

My personal record is 45 cm, which is not too bad, given the type of the spark gap used. The arcs generated by Zeus are generally between 30 and 35 cm, with occasionally some arcs longer than 35 cm.



Figure 4.3: A 40 cm spark (looks like a natural one!). 1/30s shutter speed. [Photograph: Jean-Louis Colot]

ⁱⁱA few expert have however surpassed it [18].

ⁱⁱⁱYou can refer to a very complete work by the US Navy on the subject : *VLF/LF High-Voltage Design and Testing*, referenced in the [Bibliography](#).

4.2 Primary circuit

4.2.1 Capacitor

The role of the primary capacitor is to store a certain quantity of charges (thus of energy) for the coming cycle as well as forming an LC circuit along with the primary inductor.

This is certainly the most difficult component to make on one's own. I had to rebuilt it three time before getting a working and efficient version. The primary capacitor is indeed subject to very rough treatment : it must withstand strong spikes of current (hundreds of amps) and voltage as well as very short charge/discharge times. Moreover, it must boast low dielectric losses at radio frequencies. For performance-related reason, I finally switched to factory capacitors.

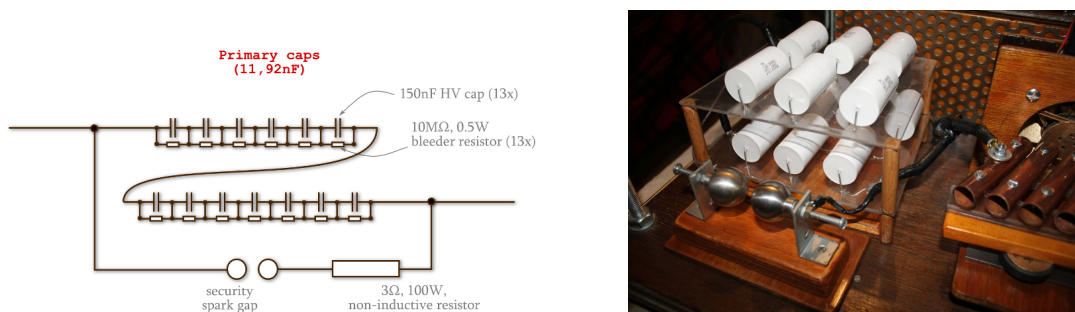

Figure 4.4: Schematic and photograph of Zeus' latest working capacitor

Its capacitance must be such as there is resonant amplification in the primary circuit^{iv}. Let's call C_{res} this specific value. If the capacitance is lower than C_{res} the energy available for the rest of the cycle will be lower. The same thing would happen if the capacitance is larger than C_{res} , but the larger capacitance allows more charge to be stored, which compensates the first problem. We'll see in section 4.2.3 [Resonant charge](#) that it might be judicious to make a "bigger" capacitor in order to prevent the amplification from becoming too powerful, which could easily destroy the transformer as well as the capacitor [20].

By definition, we could find C_{res} with formula (3.45), but we must know the total inductance of the primary circuit. We'll rather use a formula involving the impedance Z [18][21]. It's important to note that the inductance of the transformer is much greater than the inductance of the primary coil, and the same is true for their impedances ; we'll therefore neglect the primary inductor's contribution. The aforementioned formula is the following:

$$C_{res} = \frac{1}{2\pi Z f} \quad (4.2)$$

The mains current is 50 Hz in Europe and the impedance of our NST is $3.6 \cdot 10^5 \Omega$. We thus immediately get:

$$C_{res} = 8.84 \text{ nF} \quad (4.3)$$

For the reason mentioned above and because of practical constrains, I didn't respect this value when I built Zeus' capacitor. Its (measured) capacity is actually

$$C = (11.92 \pm 0.01) \text{ nF}$$

^{iv}Reminder : We have an LC circuit in series with an alternating voltage generator

Homemade plate-stack capacitors.

Building your own capacitor is an enriching experience but you should keep in mind that its performances will inevitably be lower than those of factory-made capacitors.

Using Maxwell's equations, it's possible to find a simple formula giving the capacitance C of a basic capacitor, made of two plate of area A separated by a distance d by a dielectric of permittivity ϵ . One can show that

$$C = \frac{\epsilon A}{d} \quad (4.4)$$

To increase capacitance, one can put several plates in parallel instead of just two. Then, half of the plates are, say, positive while the other half are negative. If this capacitor is made of n plates, there is $(n - 1)$ capacitors in parallel, and its capacitance is thus:

$$C = (n - 1) \frac{\epsilon A}{d} \quad (4.5)$$

The choice of the dielectric medium is of prime importance. It must have a high dielectric strength and provide low losses at high frequencies. The dielectric strength is the minimum electric field required to provoke a breakdown of the medium. The dielectric losses come from the fact that a real capacitor also possess a resistive component to its impedance (see Fig. 4.6). A fraction of the energy is then lost in the form of heat in the dielectric medium^v and in the conductors. It is however the dielectric losses that predominates and a *loss tangent* is defined for each dielectric.

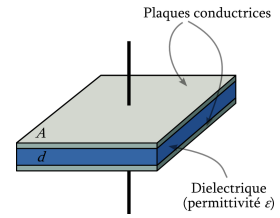

Figure 4.5: A basic capacitor. [Illustration: Wikipedia]

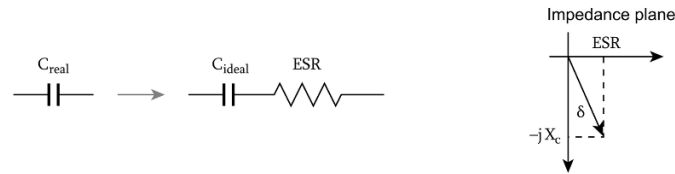

Figure 4.6: A real capacitor has an internal resistance in addition to its impedance, which is equivalent to series resistance (ESR). [Illustration: Wikipedia]

The resistive component of the capacitors impedance is called *equivalent series resistance* (ESR) and is measured by connecting a resistor in parallel to capacitor through this formula (more details on ref. [22])

$$ESR = \frac{R_p}{1 + \omega^2 C_p^2 R_p^2} \quad (4.6)$$

where

R_p is the resistance of the parallel resistor,

ω the pulsation of the alternating current

C_p the capacitance of the ideal capacitor.

The tangent loss is defined as the ratio of the real to imaginary part of the capacitor's impedance [23] (notice the analogy with the Q factor of an oscillator) :

$$\tan \delta = \frac{ESR}{X_c} \quad (4.7)$$

^vPlease note this is typical to alternating current. When a capacitor is charged with direct current, no such losses occur : all the energy is recovered at discharge.

Here is a list of possible dielectrics for high-voltage applications (table compiled from references [9][24][25][26]) :

Dielectric medium	ϵ_r at 1 MHz	Dielectric strength [kV/mm]	$\tan \delta$ at 1 MHz
LDPE	2.25	18.9 - 26.7	$8 \cdot 10^{-5}$
PP	2.20 - 2.36	24	$2 \cdot 10^{-4}$
PVC	3.00 - 3.30	18 - 50	0.015 - 0.033
Glass	4.7	17.7	0.0036
Neoprene	6.26	15.7 - 26.7	0.038

We can see that the LDPE (low density polyethylene) is a good dielectric for making Tesla coil capacitors, as it has all the required qualities and is easy to find.

When dealing with high voltages, there's certain principles to respect in order to built a enduring cap :

- A shorter distance between the plates will lead to a higher capacitance, but will increase the risk of breakdown as the field will be more intense. There's some sort of minimal distance to respect. For LDPE, I recommend *at least 0,15mm per kV (rms) supplied by the transformer.*
- It can be demonstrated that the electrical field surrounding spikes tend to be much more intense (spike effect). Therefore, the risk of breakdown will be higher at the corner of the plates. *The corners and edges of the plates must be rounded and the surfaces must be clear of any scratch.*
- The dielectric medium is likely to have imperfections (microscopic holes, impurities, etc.), which also increases the risk of breakdown. For a given thickness, *it is preferable to use multiple thinner layers instead on a single thick one* [9]. If one layer was to be damaged, the others will remain intact.
- Corona effect around the plates will gradually attack the adjacent dielectric layers, which is one more reason to prefer multi-layered dielectric. The best protection for a HV capacitor is to be drowned in an insulating oil like transformer oil^{vi}. For a given capacitance, *it is also better to build several larger capacitors with thinner dielectric and to connect them in series.* This will distribute the voltage on all the sub-capacitors and thus attenuate the Corona effect, which increases the whole capacitor's survivability for a given voltage. It is recommended to put no more than 5 kV (rms) per sub-capacitor [27].

1st version. I built this very first capacitor with Mael Flament. It was made of aluminum plates placed in an alternating pattern (see Fig. 4.8). Plates of same polarity were connected with an external screw thread that passed through holes drilled near the edge. The dielectric material was PVC.

However, the capacitance of this cap was far lower than the predicted value. I think this was because the holes were too wide to allow a good connection

I never used it on Zeus, but instead reused the plates to built a new, improved capacitor.



Figure 4.7: v.1 : never used.

^{vi}It's purified mineral oil (like silicon oil), which has the advantage of not carbonizing.

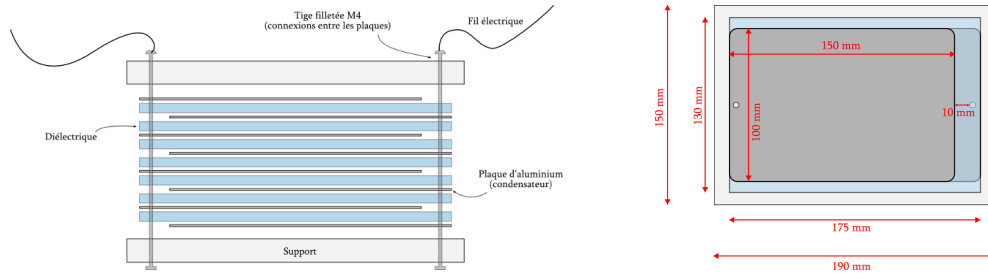

Figure 4.8: Schematics for the capacitors v.2 (similar to v.1).

2nd version. This second prototype has the same building pattern as the first, i.e. alternating plates. The major difference with the first version is the dielectric medium, which is now LDPE, much more adapted than PVC for Tesla coil operation (greater dielectric strength and reduced losses at radio frequencies). Moreover, the supports were changed to PVC instead of wood, which allowed better compression of the stack.

The dielectric is made of four sheets of 0.2mm thick LDPE, which gives a 0.8mm spacing between plates. This capacitor should thus resist voltages of at least 11.34 kV. Insulating varnish was also applied to the plates to increase survivability.

It was made of 31 plates, whose overlap area was equal to $100 \text{ mm} \times 125 \text{ mm} = 12500 \text{ mm}^2$. Its theoretical capacitance was thus (following (4.5)) :

$$C_{th} = 9.54 \text{ nF}$$

I knew however that construction defects would result in a lower real capacitance. The targeted capacitance was set a bit "too high" in order to attain a real capacitance close to the resonant value, computed at (4.3). Indeed, the overlapping area is slightly inferior to the predicted values because, first, the corners are rounded, and second, the overlapping is not perfect. Moreover, the capacitor has a tendency to "inflate" because of the lightness of the materials, and the compression with the two PVC plates was imperfect also. Finally, its measured capacitance was

$$C_{mes} = (8.31 \pm 0.01) \text{ nF}$$

To connect the plates, I had first used aluminum tape (visible in Fig 4.9), but this solution would have made sense only if the stack was immersed in oil. These sheets are indeed very thin and creases form easily, which made the surfaces very rough. When I lighted Zeus the first time, sparks were springing everywhere... on this band of aluminum tape because of Corona effect. It eventually broke because of the high currents.

Another means of connection was thus to be found, and I reused the design from the first version : a screw thread passing through holes drilled in the plates. This time, the holes were much smaller for the electrical connection to be tight. However, I was doubtful on this conception as the risk of sparks between the plates and the thread (of different polarity) was high, so insulating tape was put on the edges. Doubts were justified : after a few seconds, a bright light appeared in the capacitor with a strong smell of burned plastic : the capacitor was dead.

After several unsuccessful reparations, it became clear a brand new capacitor design was needed.

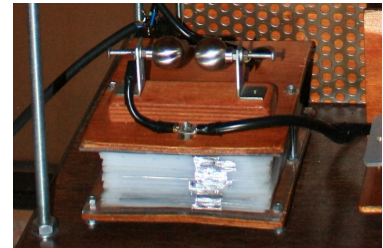

Figure 4.9: v.2 in construction and mounted on Zeus' chassis.

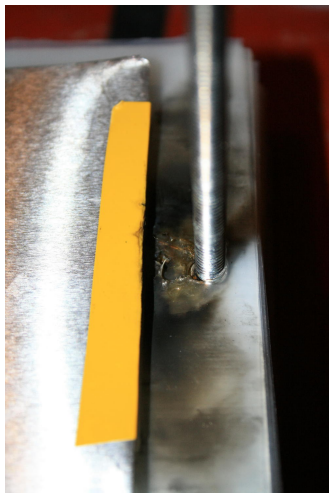

Figure 4.10: v.2 failure.

3rd version. This design turned out to be the good one. The capacitor is actually formed of two identical capacitors connected in series. As we saw earlier, this distributes the voltages between the two caps. Here, each cap is submitted to a voltage of "only" 4500 V (rms), which considerably diminishes the harmful Corona effect.

The geometry of the plates has changed as well. In order to avoid the problem of arcing between the threads and the plate's edges, a "tab" configuration was used instead (see Fig. 4.12), where the connections between plates of same polarity are much more distant of each other. This shape was harder to manufacture, but revealed to be considerably safer. The idea of this configuration came to my mind thanks to Herbert Mehlose's [28] and Jochen Kronjaeger's [29] websites. Each capacitor has 37 plates, whose overlapping area is $100 \text{ mm} \times 150 \text{ mm} = 15000 \text{ mm}^2$.

The relative spacing between the plates has also been increased. On both capacitors, the plates are separated by three sheets of LDPE whose thickness is 0.2mm, for a total of 0.6mm. As the two caps are in series, it is as if the total spacing is 1.2mm. The assembly can therefore resist voltages up to 22.7 kV (rms), nearly indestructible. It is indeed advised that the primary capacitors should be able to withstand 2 to 3 times the rms voltages of the transformer [18].

The formula (4.5) yields a theoretical capacitance of

$$C_{th}^{unit} = 18.32 \text{ nF}$$

and the total capacitance of these two identical caps connected in series is half the previous value :

$$C_{th}^{tot} = \frac{C_{th}^{unit}}{2} = 9.16 \text{ nF}$$

Apart from the above modification, the supports were also improved. The PVC plates are attached with 8 screws instead of 4, making the "sandwich" compression much better. Finally, much more insulating



Figure 4.11: An unit of v.3 ; both units connected in series and mounted on Zeus' chassis.

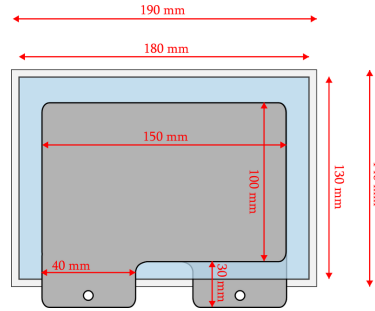

Figure 4.12: Schematic for capacitor v.3 (same color code as in Fig. 4.8).

varnish was applied. A curious fact was the capacitances of both capacitors seemed to increase slightly day by day. I think this was due to the fact that the plates gradually submitted to the imposed compression. Here are the measured capacitances:

$$C_{mes}^{unit\ 1} = (17.78 \pm 0.01) \text{ nF} \quad C_{mes}^{unit\ 2} = (18.10 \pm 0.01) \text{ nF}$$

Once both unit were assembled, I measured the total capacitance one more time:

$$C_{mes}^{tot} = (8.96 \pm 0.01) \text{ nF}$$

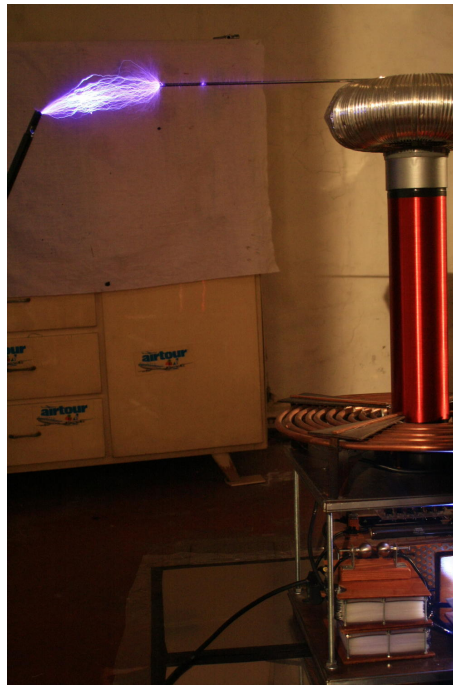

Figure 4.13: This capacitor has indeed driven Zeus, and eventually did not fail. 1s shutter speed.

While Zeus was firing, small flashes could be seen inside the capacitors. These were seemingly not due to dielectric breakdown as the capacitors continued to work. I would say these were due to overheating air bubbles, but without certitude. (ideas?)

Cornell-Dubilier 942C capacitors.

Despite the "homemade" caps working well, I wanted to build a spare capacitor (just in case), made of industrial caps. When I mounted it on Zeus, it turned out its performance were slightly better, so I decided to keep them as the permanent primary caps.

High voltage industrial capacitors are much more complex than the basic plate-stack design we just considered, and some additional criteria must be taken into account. For Tesla coils, they should have the following qualities [21] :

- Polypropylene capacitor, with metal foil-type electrodes.
- Withstand very short charge/discharge times (high dV/dt).
- Withstand high rms currents (at least 10-15 amps) and strong current spikes (several hundreds of amps).
- Self-healing ability.

I used the *Cornell Dubilier 942C20P15K-F* capacitors because they meet all these requirements (see technical datasheet [30]) and have been tested and recommended by Terry Fritz [31]. These can tolerate up to 2000 V^{vii} and have a capacitance of $0.15 \mu\text{F} \pm 10\%$. By connecting 13 of them in series (see schematic at Fig. 4.4), one gets

$$C_{mes} = (11.92 \pm 0.01) \text{ nF}$$

$$Tolerance = 26\,000 \text{ V}$$

The notion of dV/dt represents the speed at which a capacitor is charged or discharges (its units are V/s). In this context, it's not really the time-derivative of the potential but rather the maximal value it can take. For example, in a sinusoidal signal $V(t) = A \sin \omega t$ like we find in Tesla coils, the dV/dt correspond to the value of the derivative $V'(t) = A\omega \cos \omega t$ evaluated at $t = 2n\pi (n \in \mathbb{N})$, i.e. $A\omega$

The *942C20P15K-F* boasts a dV/dt of $2879 \text{ V}/\mu\text{s}$. Let's check if we'll exceed this value in the case of Zeus. The amplitude of the NST's voltage is equal to $V_{max} = \sqrt{2}V_{rms} = 12728 \text{ V}$. But with 13 capacitors in series, each one is exposed to only one thirteenth of this value, i.e. 979 V . For the angular speed, we know $\omega = 2\pi f$, where the frequency f is the resonant frequency. We'll later see it is equal to 300 kHz in our case. We thus get

$$\frac{dV}{dt} = 2\pi f \frac{V_{max}}{13}$$

$$= 1846 \text{ V}/\mu\text{s}$$

Which is indeed smaller than the value of the datasheet.

Details on construction. When building such a capacitor, it is very important to use *bleeder resistors*. These are large ohmic value (generally from 1 to 10 $\text{M}\Omega$) resistors connected in parallel to each capacitor (see Fig. 4.15). Their role is to ensure a smoother charge/discharge cycle and to prevent the capacitor from holding a dangerous charge[21]. Moreover, they'll allow the capacitors to discharge after the machine has been switched off. I used resistors of $10 \text{ M}\Omega$, 0.5 W (see technical datasheet [32]). It is also recommended to build the capacitor is such a way to avoid arcing between a capacitor and its resistor [21], they have thus been soldered on opposite sides of the PVC support.



Figure 4.14: One the units used on Zeus' main capacitor.

^{vii}This is the DC tolerance but in a Tesla coil, they'll have to deal with short pulses, so this value can actually be used [21].

In the same philosophy of extending the caps' life, it is also recommended to put a small resistance of a few Ohms in series with the security spark gap. It must have a high power rating, several hundreds of Watts, and must be non-inductive to avoid the apparition of an extra, parasitic RLC circuit around the primary capacitor. [21]. I used a 20 Ohms, 100 Watts, thick film-type resistor (see technical datasheet [33]), visible on the left extremity of the brown wire on Fig. 4.16.



Figure 4.15: v.4 during construction.

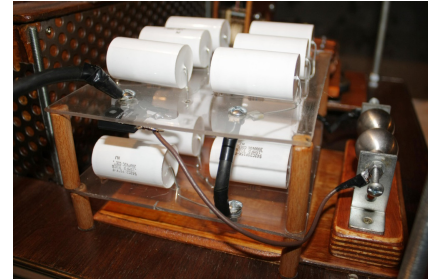

Figure 4.16: v.4 mounted on Zeus' chassis.

4.2.2 Charge at resonance

Let's talk briefly about the "good" capacitance of the primary capacitor. In the previous section, we had chosen its capacity so a resonant amplification occurs at 50 Hz. This ensures all the energy of the transformer is used, as the impedances of the transformer and the primary circuit are identical. This choice is risky however, as in case of spark gap fault, voltage and current rise to enormous values in a few tens of seconds, which can destroy the caps as well as the transformer.

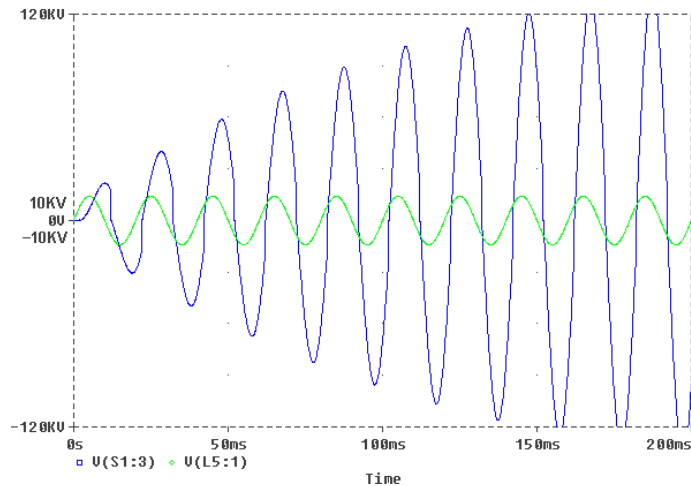

Figure 4.17: Plot of NST shorted (green) and in primary circuit (blue) output voltage over time in case of resonance (simulation for a 10 kV, 100 mA NST ; $L = 318$ H ; $R = 5000$ Ω). [Diagram: Richard Burnett]

The next plot show the maximal values that voltage and current can attain in a primary circuit fed by a 10 kV, 100 mA NST in series with a resonant-sized cap. The ballasts' inductance is 318 H and the total resistance is 5000 Ω . We can see that, without a spark gap (or any other device evacuating the energy), voltage can rise up to 200 kV and current up to 2 A [20].

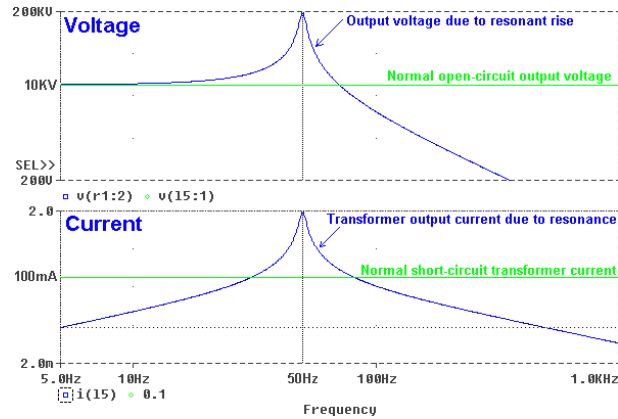

Figure 4.18: Using a resonant-sized capacitor will have the voltage and the current reach values far beyond what components can withstand. [Diagram : Richard Burnett]

Normally, the spark gap will fire above a given voltage (which is far lower than the previous values), making the current and the voltages across the capacitor fall to acceptable levels. But, for some reason, the spark gap may fail to fire once in a while. This is quite frequent actually, especially for static spark gaps such as Zeus’ gap, as they have a tendency to fire rather erratically, as show in Fig. 4.19.

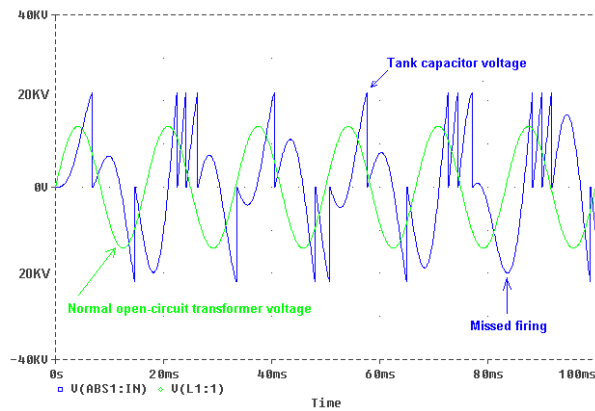

Figure 4.19: Plot of the voltage output of the transformer (green) and the voltage across the capacitor (blue) over time with a static spark gap. This situation depicted here is much more realistic than in Fig. 4.17. [Diagram: Richard Burnett]

Conclusions.

The resonant amplification in the primary circuit is a very important phenomenon for good Tesla coil performances, but it must remain under control so as not to damage the components. This is why it is strongly recommended to place security devices around sensitive components.

In this philosophy, a *security spark gap* is generally placed at the lead of the primary capacitor (visible on Fig. 4.4). The NST protection filter is a bit more complex and we’ll talk about it later.

It is also recommended to use a *non-resonant-sized capacitor*, in other words, whose capacitance will not lead to a brutal resonant amplification. This larger-than-resonance (LTR) value depends on the type

of spark gap used. For a static spark gap, typical values for the LTR capacitance range from 1.5 to 2 times the resonant capacitance (given by formula (4.2)) [18]. Kevin Wilson recommends the value of 1.618 times the resonant value, as this value (an estimation of the golden ratio), will ensure no common integer multiples [21]. Following this approach, the LTR capacitance of Zeus will be around

$$C_{LTR} = 14.30 \text{ nF}$$

The capacitance of Zeus' primary caps is approximately 1.35 times the resonant value, which is perhaps a bit close to the resonant value. But the various protection measures seem to be working well as no sensitive component has been damaged (so far).

As mentioned earlier, such an increase in the primary capacity has almost no consequences on the global performances of a Tesla Coil. Richard Burnett has shown that, with a static spark gap, the delivered power depends much more on the spark gap spacing than on the primary capacity [20].

4.2.3 Inductance

The role of the primary inductor is to generate a magnetic field to be injected into the secondary circuit as well as forming an LC circuit with the primary capacitor. This component must be able to transport heavy current without excessive losses. The resonance tuning is traditionally made on this component as we'll see later.



Figure 4.20: Schematic and photograph of Zeus' primary inductor (secondary circuit removed).

The primary winding has been tapped to 8.25 turns and has a measured self-inductance of

$$L_{mes} = (0.03 \pm 0.01) \text{ mH}$$

This very approximative value has been measured on a small LCR bridge. A more precise device could be used but the tuning is made via a trial-and-error method, so knowing the exact inductance is not of prime importance.

Different geometries are possible for the primary coil. We'll look at the most common one before examining more thoroughly the case of Zeus. Note that the formula giving the self-inductances for each of them are approximative and are just used to have a rough idea of the number of turns required to achieve proper tuning.

Helical geometry. The inductor looks like a solenoid with widely spaced turns. Such a geometry will cause quite high coupling between the primary and secondary circuits, which is not always a good thing as we discussed in 3.3.5 Influence of the coupling. Apart from the overcoupling problem, having a high primary increases the risk of arcing between the top load and the primary, which is potentially catastrophic. Indeed, enormous voltages are applied to a circuit that is not designed to handle them, which can lead to destruction of the primary capacitors or/and the transformer if not properly protected. To solve this issue, the base of the secondary coil can be raised above the primary.

This design has not proven very efficient however [8].

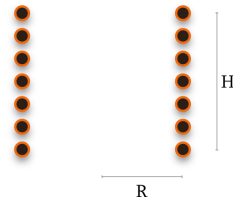

If we call R the radius of the helix, H its height (both in centimeters) and N its number of turns, an empirical formula yielding its inductance L in microhenrys is [9].

$$L_{helic} = \frac{0.374(NR)^2}{9R + 10H} \quad (4.8)$$

Archimedes' spiral geometry. This geometry naturally leads to a weaker coupling and reduces the risk of arcing in the primary : it is therefore preferred on powerful coils. It is however rather common in lower power coils for its ease of construction. Increasing the coupling is possible by lowering the secondary coil into the primary. Zeus' primary inductor has this shape.



Let W be the spiral's width given by $W = R_{max} - R_{min}$ and R its mean radius, i.e. $R = (R_{max} + R_{min})/2$, both expressed in centimeters. If the coil has N turns, an empirical formula yielding its inductance L in microhenrys is [9] :

$$L_{flat} = \frac{0.374(NR)^2}{8R + 11W} \quad (4.9)$$

Hybrid geometry. This conical configuration is a sort of compromise. It allow a fair coupling between the two circuits and is rather safe as well. It's the most common configuration for low power coils. A posteriori, I think such a geometry would have been a better choice for Zeus, despite being more difficult to built.

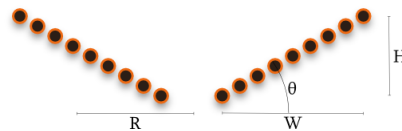

By defining the parameters H , W , R and N as previously, the self-inductance is computed by doing an average of the values L_{helic} and L_{flat} weighted by the angle θ of the cone with the horizontal plane [34][9].

$$L_{hybrid} = \sqrt{L_{helic} \cos^2 \theta + L_{flat} \sin^2 \theta} \quad (4.10)$$

Case of Zeus.

Zeus' primary inductor has a plane spiral geometry, tapped at 8.25 turns. Its internal radius $R_{min} = 7$ cm and its external radius (at 8 turns) $R_{max} = 44$ cm. From here, we find $W = 37$ cm and $R = 25,5$ cm following the previous definition. Its computed inductance is then :

$$L = \frac{0.374(8.25 \times 25.5)^2}{8 \times 25.5 + 11 \times 37} = 27.1 \mu\text{H}$$

which is close to the measured value. It must be kept in mind however that the primary's real inductance will be slightly higher than this value, as the latter neglects the wirings used to connect the components. These wirings indeed form a closed loop which contains some ferromagnetic materials (screws, bolts, etc.). This extra inductance is somewhat wasted as its magnetic field is far from the secondary and will not contribute to it's resonance.

Some details must be taken into account in order to keep this parasitic inductance as low as possible. Avoid loops in the wiring and make it as short as possible. It is also recommended to avoid placing wires parallel to each other to avoid induced currents [35].

Skin effect.

To minimize energy losses, the resistance of the primary circuit must be made as low as possible. This implies the use of good conductors as well as a large conduction area. It is easy to imagine the practical limitations of this idea. For example, if we wanted to make a spiral from a 12 meter rod of 1.2cm diameter made of massive copper (this is roughly the dimension of Zeus' primary inductor). This spiral would weight 12 kg and would require advanced machinery to be bend. And the cost would be terrific.

Fortunately, we can make use of a propriety of high-frequency currents. The *skin effect* is the fact that, at high frequencies, the current flow mainly on a thin layer near the outer surface of the conductor ^{viii}. We'll see how this justifies the use of hollow copper tubing (as plumbing pipes), much easier to handle.

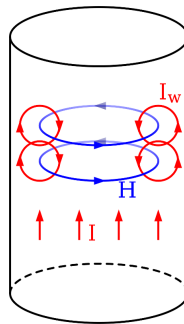

Figure 4.21: Alternating current I creates an alternating magnetic field H , which will generate eddy currents I_w . [Illustration: Wikipedia]

Skin effect is easily explained by magnetic induction. When an alternating current flows in a conductor, it will generate a magnetic field around it, which is also alternating. Lenz' law then says that these variations of magnetic field will lead to the apparition of an emf that will tend to attenuate these variations.

^{viii}This is not rigorously correct actually. The surface of the conductor on which the current will flow will depend on the ambient magnetic field. For example, in the outer conductor of a coaxial cable, current will flow on its *internal surface*.

Eddy currents will therefore appear, as shown in Fig 4.21, which will oppose the main current in the center of the cylinder but not near its edges. When current \vec{I} goes in the opposite direction, so will \vec{H} and \vec{I}_w and the previous discussion holds for both directions.

It can be shown that the current density $J(d)$ in a cylindrical conductor follows an $1/e$ law from the edges to the center [36] :

$$J(d) = J_S e^{-d/\delta} \quad (4.11)$$

where

- d is the depth (i.e the distance from the surface),
- J_S the current at the conductor's surface, $J_S \equiv J(d = 0)$,
- δ is the "skin depth", a parameter depending on the material.

Taking $d = \delta$ in (4.11), we see that δ represents the depth at which the current density is only 0.37 (1/e) times the density in the surface. Computing the skin depth is complicated in the general case. However, with a good conductor and at reasonable frequencies ($< 10^{18}$ Hz), the following formula is a very good approximation [36] :

$$\delta = \sqrt{\frac{2\rho}{\mu\omega}} \quad (4.12)$$

where

- ρ is the resistivity of the conductor ($1.7 \cdot 10^{-8}$ Ωm for copper [25])
- μ is magnetic permeability ($1.26 \cdot 10^{-6}$ H/m for copper [25])
- ω the angular speed of the current, equal to $2\pi f$.

Let's compute the skin depth for copper, the conductor Zeus' primary inductor is made of, at the frequency of 300 kHz, its resonant frequency :

$$\delta_{\text{Cu}} \approx 0.12 \text{ mm}$$

We can also calculate the ratio between the current that flows through a plain cylinder and the current that flows into a hollow one. The tubing used for Zeus' winding is 1mm thick and has a diameter of 12mm.

We find the current I by integrating $J(r)$ over the considered cross-section. We set $d = R - r$, where R is the cylinder's radius (6mm) and r the radial distance, which we'll integrate. We get :

$$I_{\text{plain}} = \int_0^{2\pi} d\theta \int_0^6 r dr J_S e^{-(R-r)/\delta} \quad \text{and} \quad I_{\text{hollow}} = \int_0^{2\pi} d\theta \int_5^6 r dr J_S e^{-(R-r)/\delta}$$

Computing these integrals, we find :

$$I_{\text{plain}} = 2\pi J_S \delta \left[(r - \delta) e^{(r-R)/\delta} \right]_0^6$$

$$I_{\text{hollow}} = 2\pi J_S \delta \left[(r - \delta) e^{(r-R)/\delta} \right]_5^6$$

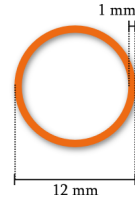

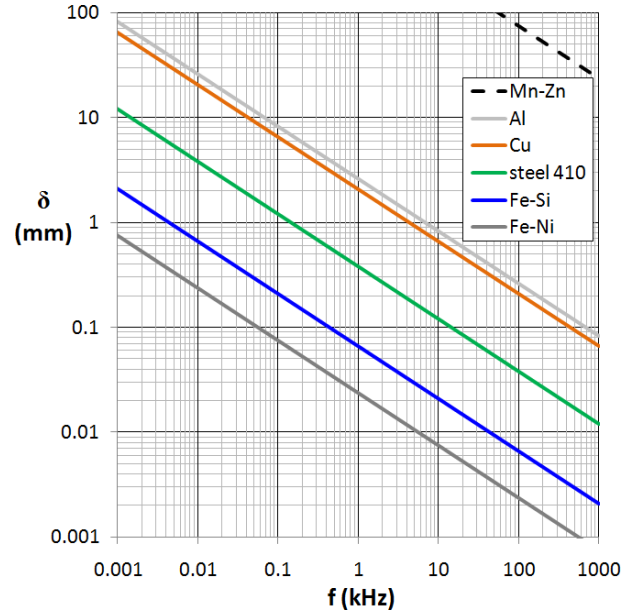

Figure 4.22: Log-log plot of skin depth δ as a function of frequency f for various mediums. [Diagram: Wikipedia]

We're only looking at the ratio between the two, to cancel out the unknown factor J_S :

$$\begin{aligned}
 \frac{I_{hollow}}{I_{plain}} &= \frac{[(r - \delta)e^{(r-R)/\delta}]_5^6}{[(r - \delta)e^{(r-R)/\delta}]_0^6} \\
 &= \frac{(6 - \delta) - (5 - \delta)e^{-1/\delta}}{(6 - \delta) - \delta e^{-6/\delta}} \\
 &\approx \frac{5.8788}{5.8800} \\
 &\approx 99.98 \%
 \end{aligned}$$

In other words, the current gain we'd have by using a plain tube is only 0.02%, a ridiculous value. Using a hollow tubing is therefore perfectly adapted. The drawback of this high-frequency propriety is that the effective resistance is much higher than in DC, as the current is forced to flow on thin layer instead of on all the conductor (and this, whatever the cross-section of the conductor is) [36].

4.3 Spark gap

The function of the spark gap is to close the primary LC circuit when the capacitor is sufficiently charged, thus allowing free oscillations inside the circuit. This is a component of prime importance in a Tesla coil because its closing/opening frequency will have a considerable influence on the final output [37].

An ideal spark gap must fire just when the voltage across the capacitor is maximal and re-open just when it falls down to zero. But this is of course not the case in a true spark gap, it sometimes does not fire when it should or continues to fire when the voltage has already diminished ; we'll see which factors will make a spark gap efficient.

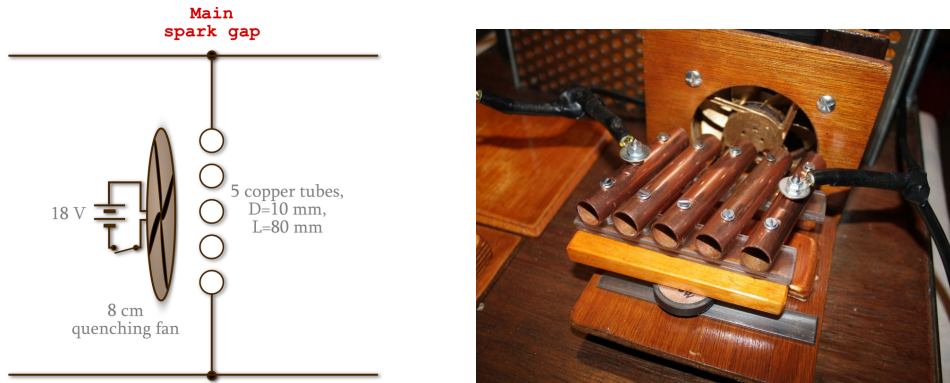

Figure 4.23: Schematic and photograph of Zeus' (static) spark gap.

Two types of spark gap.

Static. In a static spark gap, there's two or more electrodes spaced by a given distance. When the potential difference between them rises above some critical value, the air is ionized and thus becomes conducting. This closes this gap, allowing current to flow.

The critical intensity of the electrical field above which air breakdown occurs depends on many parameters (humidity, temperature, air composition, etc) and it is difficult to predict it in the general case ; gas breakdown itself is a very complex phenomenon. The generally admitted value, which is nothing more than an order of magnitude, is $E_C = 3 \cdot 10^5$ V/m [38]. Using this value in the spark gap design^{ix} will not yield expected results. Indeed, apart from factors related to air itself, the geometry of the electrodes will influence the intensity of the field for a given potential difference as well.

It's much more efficient to build an *adjustable* spark gap and to find the optimal distance afterwards, by trial-and-error. This is done by first setting the distance to an obviously too short value, lighting the coil and observing the result. Next, spacing the gap a little bit and trying again until the arcs at the top load are the longest.

If the electrodes are too close, the gap will fire while the capacitor is not full, which will considerably diminish the coil performances. If they are too distant, the spark will simply not fire and the coil doesn't work. The latter case is much more dangerous as we discussed in section 4.2.2 [Charge at resonance](#). If the primary circuit is correctly conceived however, the security gap will take over and will bypass the fragile components.

Static spark gaps are easy to construct but generally have poorer performance than their rotating counterpart [37]. They have a tendency to fire erratically and to carry on firing when voltage has diminished. Moreover, the path of ionized air has a certain resistance.

Rotative. On this kind of spark gap, it's no longer the voltage that closes the circuit. Here, we have basically a conducting rod that spins rapidly between electrodes. When the rod is at its closest distance from the electrodes, current flows via small paths of ionized air. When the rod offsets from this position, current flow stops, which re-opens the gap.

There are many ways to build such a rotative gap (several rods, several pairs of electrodes, synchronous or asynchronous motor, etc.).

This kind of spark gap is more precise and yields better results, but is more difficult to build and adjust. Indeed, it must be built in such a way so the rod passes in front of the electrodes just when the

^{ix}For example, setting the inter-electrode distance to 1 cm, hoping breakdown will occur when the potential difference between them will reach 30 000 V

voltage difference across the capacitor is maximum.

Details about construction.

Zeus' spark gap is a static one. As mentioned earlier, they tend to remain open after the voltage has diminished. This happens because the path of ionized air demands a much lower voltage to live on than it requires to be created.

In order to improve its performances, the gap has to be *quenched*, that means to be forced open. Here's a few strategies for that.

One is to force a large, continuous flow of air inside the spark gap, in order to chase the ionized air. Sucking the air is also possible (for example, with vacuum cleaner parts) and gives good results as well[39].

Blowing air into the gap has many benefits. This not only quenches the gap but also cools it. Because the critical breakdown field decreases with temperature and the high current crossing the spark gap will indeed increases its temperature, the spark gap will fire at a lower voltage after a few seconds (and the sound of the spark gap becomes notably more high-pitched), hindering the coils performances [37]. Thus cooling the gap will prevent such problems.

It is also possible to use more than two electrodes. The single arc will then be divided into so many smaller arcs, which will quench more easily. The drawback of this configuration is that all these sub-arcs will act like series resistors : all of them will dissipate energy in the form of light, heat and noise. The *Richard-Quick* design makes use of several copper tubes disposed in parallel [40]. I used this model for Zeus' gap.

The spark gap has to deal with enormous current, with transient spikes of nearly 300 amperes. This leads to the apparition of strong corrosion on the electrodes, which will also hinder the coils performances. It is necessary to regularly clean/sand them.

1st version. The first spark gap I built was made of 5 identical copper tubes, 10mm in diameter, 80mm long. These were fixed on a flexible membrane following a design found on ref. [41]. By bending this membrane, one can modify the distance between the electrodes. The whole assembly was placed in front of a 12 V personal computer fan with a diameter of 80mm. Power was supplied by two 9V batteries connected in series.



Figure 4.24: Heavy corrosion between the copper tubes.

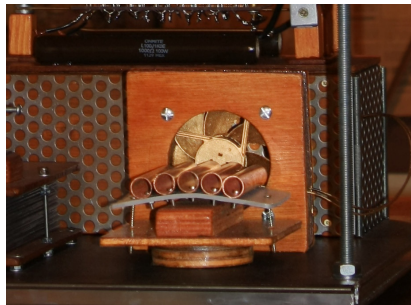

Figure 4.25: v.1 mounted on Zeus' chassis.

The membrane must be made of an insulating, fire-resistance material. I used foamed PVC, which is auto-extinguishable. Its flexibility was not excellent however and didn't allow a good distance setting. As I tried to bend it more, it eventually broke.

This spark gap was not easy to maintain either. The repeated action of sanding the surfaces had a tendency to loosen the fixations of the tubes. A better design was to be found.

2nd version. This spark gap was made of the same copper tubes as before. The difference here is the mounting. The tubes are loosely fixed at both extremities on PVC supports. The support close to the fan was immobile while the other could be horizontally translated (the magnet on metal bar ensured the stability of the assembly).

The spacing between the tube can thus be adjusted by shearing the assembly. This design proved more precise and easy to maintain.

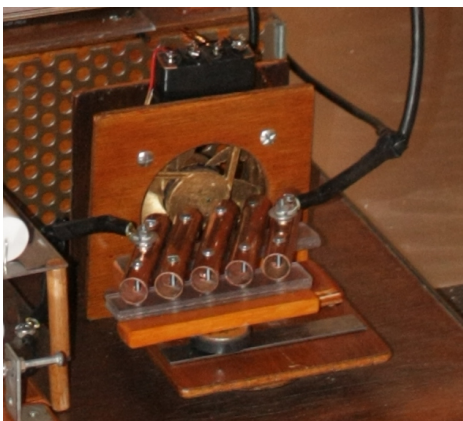

Figure 4.26: v.2 mounted on Zeus' chassis.



Figure 4.27: The power supply of the fan.

4.4 Secondary circuit

4.4.1 Coil

The function of the secondary coil is to bring an inductive component to the secondary LC circuit and to collect the energy of the primary coil.

This inductor is an air-cored solenoid, generally having between 800 and 1500 closely wound adjacent turns. In the Zeus Tesla coil the secondary coil is made of enameled copper "magnet wire" with a diameter of 0.5mm (SWG 24) which is wound around a PVC pipe of 100mm external diameter. The coil is 40.2cm tall.

To calculate the number of turns that have been wound, this quick formula will avoid a certain fastidious work:

$$N = H/d \quad (4.13)$$

where H is the height of the coil and d the diameter of the wire used. In our case, the number of turns is 790 turns (more or less a few turns). It is quite low, but the diameter of the coil is rather large in comparison of the coil's power ; this will provide a fair self-inductance while limiting parasitic capacity.

Another important parameter is the length l we need to make the entire coil. It is given by

$$l = 2\pi Nr \quad (4.14)$$

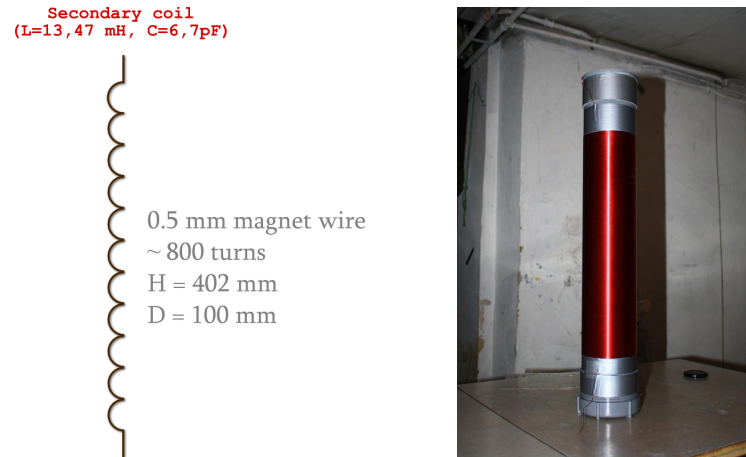

Figure 4.28: Schematic and photograph of Zeus' secondary coil.

where r is the radius of the coil. Zeus' coil has thus necessitated 248 meters of wire.

One can show that the self-inductance L in henrys of a adjacent-turns solenoid is given by

$$L = \mu \frac{N^2 A}{H} \quad (4.15)$$

where μ represents the magnetic permeability of the medium ($\approx 1.257 \cdot 10^{-6} \text{ N/A}^2$ for air, very close to the value of the void), N the number of turns of the solenoid, H its total height, and A the area of a turn.

Injecting Zeus' coil values, we get

$$L_{th} = 15.17 \text{ mH} \quad (4.16)$$

which is not too far from the value measured from an LCR bridge :

$$L_{mes} = (11.92 \pm 0,01) \text{ mH} \quad (4.17)$$

Characteristics

Resistance. During the first tries of Zeus, I had placed the secondary coil lower in the primary spiral in order to increase coupling. This didn't yield the expected results : arcing between the primary and secondary occurred, which damaged the coil at several points, as shown in Fig. 4.29. I thus put the secondary coil back in its initial position. Fortunately, the coil hasn't been sectioned. The only noticeable consequence was an increase of the coil's resistance, increasing from 20 to 25 Ohms.

However, this value was measured with a classical ohmmeter, i.e. with a direct current. But what will flow in the coil is high-frequency alternating current. A more precise measure would include effects such as skin effect and proximity effect. The method proposed by Fraga, Prados and Chen [42] takes these effects into account and has been proven to be precise for solenoids. The JAVATC simulator yielded the following value ("Fraga AC resistance") :

$$R_{ac} = 94.856 \Omega$$



Figure 4.29: Results of inadequate space between the coils : arcing between the two occurred, burning the secondary coil at several points.

Inductance and capacitance at resonance. The inductance calculated at (4.16) and measured at (4.17) are again valid for low frequencies only. The self inductance of the secondary coil driven at resonance is slightly different, because of the non-uniform repartition of current and because the length of the coil is comparable to the wavelength of the signal it will carry [43]. Once again, a more precise formula must be used. The JAVATC simulator gave the following value ("Effective series inductance") :

$$L_{res} = 13.471 \text{ mH}$$

It's also interesting to know the (parasitic) capacitance of the coil [44]. Here also the formula is complicated in the general case. We'll use the value yielded by JAVATC ("Effective shunt capacitance" without top load) :

$$C_{res} = 6.74 \text{ pF}$$

Q factor. We can now compute the Q factor of the coil, following formula (3.51) established in the last chapter, $Q = R^{-1} \sqrt{L/C}$. To get a coherent result, we'll use the previous values for R, L and C (with top load capacitance added). We thus get :

$$Q = 285$$

Which is a rather good value, that will indicate low losses in the secondary LC circuit. It is difficult to surpass 500 with common conductors.

Note that it is also possible to measure the Q factor experimentally following the procedure detailed in ref. [45].

Quarter-wave antenna.

We saw in section 3.4 [Quarter-wave antenna](#) how we could apply this model to the Tesla coil. In the next section, we'll calculate the resonant frequency f of the secondary coil to be $3.19 \cdot 10^5$ Hz. The corresponding wavelength is $\lambda = c/f$ (where c is the speed of propagation of the wave : here, $c \approx 2.998 \cdot 10^8$ m/s), i.e. approximately 940 m. In other words,

$$\lambda/4 = 235 \text{ m}$$

As the total length of the wire in Zeus' secondary coil is around 248 meters, we can conclude it is correctly tuned like a quarter-wave antenna. But as mentioned earlier, this is not necessary [8], that is why we performed such rough calculations^x.

^xActually, we should have used the speed of propagation of the wave in copper for c , instead of the vacuum, but both value are actually rather close [15].

Construction.

This component is not especially difficult to build but requires a lot of patience. The 800 turns have been wound entirely by hand and took a few days. Precautions had to be taken in order to prevent sweat from infiltrating the coil.

The very high voltages involved can cause arcing between turns if the coupling is set too high ^x[xi](#). It is common to apply an insulating resin on the coil, which will reinforce the insulation already provided by the polyurethane covering the magnet wire. I couldn't find such a resin so I instead applied liberal amounts of insulating spray (the same used in the capacitors).

There's an important empirical rule about the ratio between the height H and the diameter D of the coil. It has been observed that the best performances are attained with an H/D ratio between 3 and 5 [\[46\]\[47\]](#). Zeus' coil is thus conform with a ratio of 4 (see Fig. 4.28).

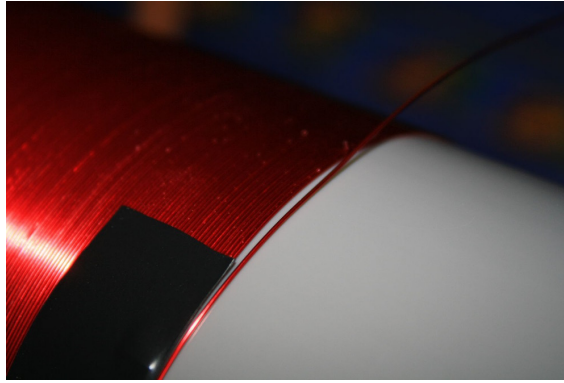

Figure 4.30: "Keep calm and carry on."

4.4.2 Top load

The top load acts like the upper "plate" of the capacitor formed by the top load and the ground ^{xii}[xii](#). It adds capacity to the secondary LC circuit and offers a surface from which arcs can form. It is possible, actually, to run a Tesla coil without a top load, but performances in terms of arc length are often poor, as most of the energy is dissipated between the secondary coil turns instead of feeding the sparks [\[7\]](#).

There are many different possibilities regarding the shape of the top load, the most common ones being the sphere and the toroid. Computing its capacitance is difficult in the general case (a collection of empirical formulas are given in ref. [\[13\]](#)). The JAVATC program gave the next value :

$$C_s = 14.172 \text{ pF}$$

Influence of geometry.

The top load is perhaps the most important component when determining the final arc length (except the transformer of course). There is a lot of discussion about its optimal size.

In a general way, a larger top load will have a larger capacitance. Regarding formula (3.57) specifying the voltage gain, one could think it is desirable to keep the secondary capacitance as low as possible, as V_{out} decreases when C_s increases. However, if the top load capacitance is low (or nonexistent), the majority

^x[xi](#) See [3.3.5 Influence of coupling](#).

^{xii}[xii](#) See [3.3.4 Distribution of capacitance in the secondary circuit](#).

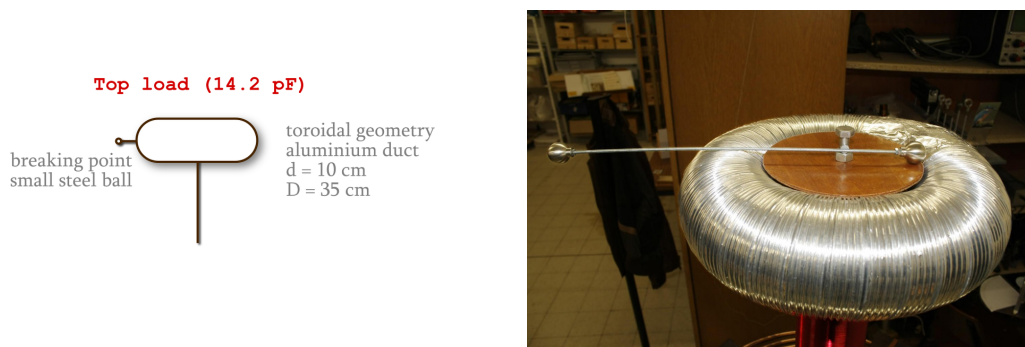

Figure 4.31: Schematic and photograph of Zeus' top load

(resp. the totality) of the secondary capacitance will be located in the secondary coil itself. Then, the energy of the secondary circuit is mainly dissipated as heat between the turns instead of feeding the sparks [7]. Hence an optimal capacitance exists.

The toroidal geometry is often preferred instead of the spherical. If the top load is a sphere, the near electrical field will be more uniform, which will result in more numerous, shorter sparks. But with a toroidal geometry, the electrical field is more intense on the outer edge of the toroid : there will be fewer sparks but longer on average, most of the arising from this outer edge.

Be it toroidal or spheric, the *curvature radius* of the load will increase with its size. And the larger the curvature radius is in a certain zone, the weaker the electric field will be. Fewer spark will be able to form, and the available energy for each of them will be greater. This will result in less numerous but longer sparks. It is even possible to make the top load big (and smooth) enough so not a single arc can form [48]. Conversely, if the curvature radius is smaller, the electrical field will be intense in many zones, allowing more sparks to be formed ; these will be shorter as the available energy will have to be distributed between all these arcs. There is thus also an optimal size to the top load.

State of the surface. Another important parameter influencing the final arc length is the roughness of the top load surface. If the surface has asperities, the electric field near these will be much more intense. It can indeed be shown from Maxwell's equations (Gauss' law to be precise) that the electrical field is more intense near zones of strong curvature. This fact is called the *spike effect*.

If one wishes to get longer sparks, it will be judicious to have a smooth top load ; to reduce the number of breakout points and thus of sparks (see for example ref. [49]).

Addition of a breaking point. In order to force sparks to be generated at a single point (and thus having longer arcs), it is possible to add a breaking point to the top load. By spike effect, this will ensure the electrical field is comparatively much stronger near this zone.

It has been suggested that the breakout point should be a ball instead of a spike. This will allow the spark base to "glide" on it, giving more time for the spark to develop^{xiii}. Because of the higher temperature of the ionized air path, it will indeed have a tendency to rise.

Details of construction.

^{xiii}See 3.3.1 Description of a cycle.

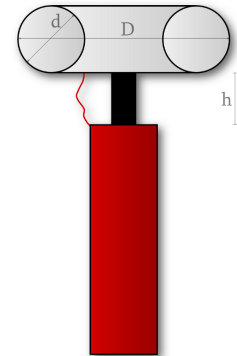

Figure 4.32: Numerous sparks arising from the top load asperities. Notice Zeus' Eagle. 1s shutter speed.

A toroidal top load was used on Zeus.

There are a few empirical rules regarding the dimension of the toroid. Let's call d its minor diameter and D its major diameter, like shown in adjacent figure. d should be equal to the secondary coil diameter (10cm here) and the D/d ratio should be between 3 and 4.

The top load position is also subject to some guidelines. If it is too close from the top of the secondary coil, its electrical field will "drown" the last spires, which will result in a lower final voltage. Conversely, if the top load is too high, its electrical field cannot protect the last spires and the risk of inter-arc spark and Corona losses increases. If we call h the distance between the base of the top load and the top of the secondary coil, it is recommended to have $d \approx h$ [49].



1st version. The first toroid I made had a minor diameter $d = 8$ cm and a major diameter $D = 28$ cm. Its theoretical capacitance was 13.5 pF.

It was made of flexible aluminum duct. It has been rolled around a support made of two discs, one in wood (top) and the other in aluminum (bottom). The toroid was closed with aluminum tape.

The connection with the secondary coil was made with a luster connector. On the next picture, one can spot a small Corona "leak" at this point because of the roughness of the screws.

This toroid produced the very first sparks of Zeus. Their size was modest, because of the capacity of the top load was too low. To enhance performances, Kevin Wilson suggested to build a new, larger toroid.



Figure 4.34: The very first sparks of Zeus. A lot of emotion. 1s shutter speed.

2nd version. This is the final version of Zeus' toroid. The same construction method was used, only dimensions changed : $d = 10$ cm, $D = 35$ cm. The rod serving as a breakout point is attached with a

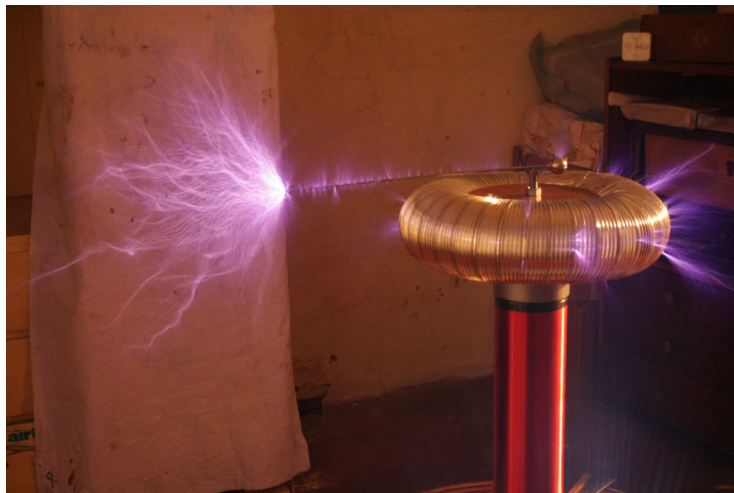

Figure 4.33: Adding a spike forces the sparks to break from a single point, to a certain extent. Their length also increases. 3.2s shutter speed.

neodymium magnet. Fig. 4.33 attests of the great difference between the two top loads in terms of arc length.

I just had to retune the primary inductance in order to make the two circuits resonate. We'll discuss this point in the next section.

4.5 Resonance tuning

Setting the primary and secondary circuits at resonance, i.e. have them share the same resonant frequency, is of prime importance for good operation. As discussed in 3.2 LC circuit, the response of an RLC circuit is the strongest when driven at its resonant frequency. In a good RLC circuit, the response intensity falls sharply when the driving frequency drifts from the resonant value.

Let's have a look at Zeus' case. We compute the secondary resonant frequency with its capacitance C_s and its inductance L_s with the well-know formula (3.46), $f = (2\pi\sqrt{L_s C_s})^{-1}$. The secondary capacitance is equal to the coil capacitance plus the top load capacitance, computed by taking into account the non-uniformity of the current distribution. But the non-uniformity of the current distribution[44]. The JAVATC simulator gives a value for the total secondary capacitance (Effective shunt capacitance), $C_s = 18.425$ pF. Let's also recall the secondary inductance : $L_s = 13.471$ mH.

We thus get

$$f_{res} = 319.46 \text{ kHz}$$

Tuning methods.

The tuning is generally done by adjusting the primary inductance, simply because it's the easiest component to modify. As this inductor has wide turns, it is easy to modify its self-inductance by tapping the final connector at a certain place in the spiral.

The simplest method to achieve this adjustment is by trial-and-error. For this, one begins to tap the primary at a point supposedly close to the resonant one, lights the coil and evaluates arc length. Then the spiral is tapped a quarter of turn forward/backward and one re-evaluates the result. After a few tries one can proceed with smaller steps, and will finally get the tapping point where the arc length is the

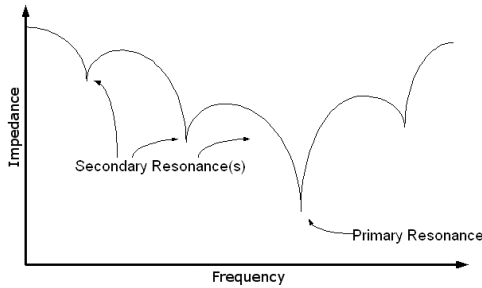

Figure 4.35: Because of the non-ideal behavior of the components, the secondary circuit can exhibit more than one impedance minimum. [Diagram: Jamie Oliver]

highest. Normally, this tapping point will indeed set the primary inductance such as both the circuits are at resonance. I used this procedure for Zeus and tapped the primary to 8.25 turns.

This method isn't infallible however. It presupposes that there is one and only one resonant point. This would be true if current and voltage distribution were uniform. And we saw the secondary coil has a distributed capacitance and deals with non-uniform current/voltage distributions. This may lead to the apparition of several secondary resonances (see Fig. 4.35), i.e local but not necessarily global impedance minima [50]. By proceeding though the trial-and-error method discussed above, one can think they've reached the true resonant value but actually have a secondary resonance.

A more precise method would involve an analysis of the individual response of both the circuits (in the coupled configuration, of course, i.e. without physically separating the circuits) with a signal generator and an oscilloscope. Detailed procedure are given in refs. [51] [50].

Arcs themselves can produce some extra capacitance [14]. It is therefore advised to set the primary resonant frequency slightly lower than the secondary, in order to compensate for this. This is noticeable however only with powerful Tesla coil (which can produce arcs longer than 1m), and should have little influence on Zeus.

4.6 RF ground

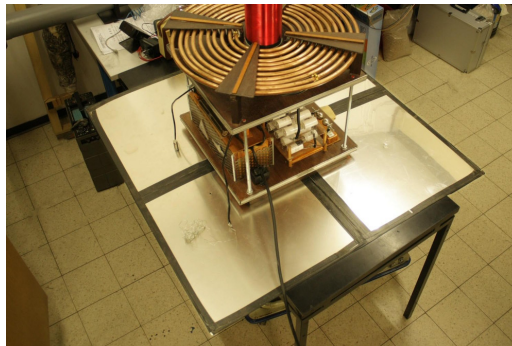

Figure 4.36: Zeus' RF ground is made of an 1 squared meter aluminum plate.

It is the ground at which the bottom of the secondary coil is connected. Its role is to keep the voltage at the base of the coil at zero, but also (more importantly) to act like the second "plate" of the top load-ground capacitor. In this light, it makes the secondary capacitance less dependent of the immediate environment.

The best grounding method is to use a metallic rod stuck into the soil ; when this option is not possible, one has to make his own ground. For this purpose, it is possible to use a large metallic plate, placed underneath the Tesla coil. Its total width should be equal to twice the distance between the top load and the base of the secondary coil [52]. Zeus being 1.10m high, a plate 2.2m wide would be required. The plate used on Zeus is only 1m wide but seems to be sufficient. It is made of 4 panels of 50cm \times 50cm bound with aluminum tape and covered by stronger, convectonal tape for protection. This allow the plate to be folded, which increases transportability.

Zeus' plate is made of plain metal, but it is also possible to use a conducting mesh. This is actually better as it prevents some eddy current from taking place.

4.7 Other components

4.7.1 NST protection filter

Tesla coils give a harsh treatment to the main transformer. We saw that it must withstand powerful transient currents and voltages as well as high-frequency alternating current. To ensure long transformer life, it is highly recommended to protect it. We mentioned earlier that it is not possible to use a differential circuit breaker as it will open the circuit as soon as resonant amplification attains higher values, thus forbidding any Tesla coil use.

Terry Fritz has however designed an NST protection filter specifically made for Tesla coil operation [53]. It is made of a grounded spark gap, low-pass filters and varistors and is connected between the transformer and the primary circuit. Such a filter has been used on Zeus.

Note that a filter is necessary only with NSTs, because of their fragility. Other kinds of transformers (MOT, pole pigs, etc) are rugged enough to support Tesla coil operation as is [54].

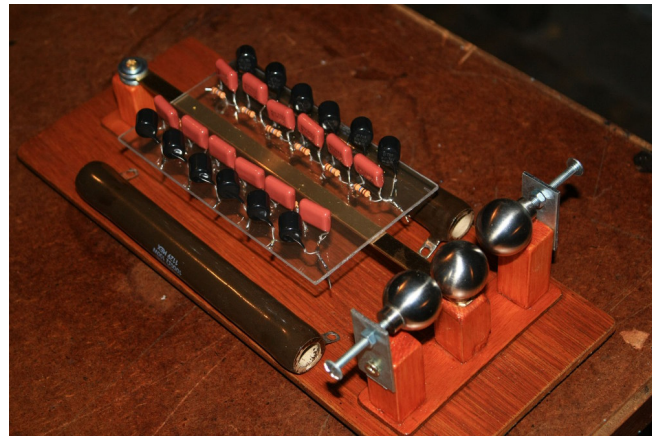
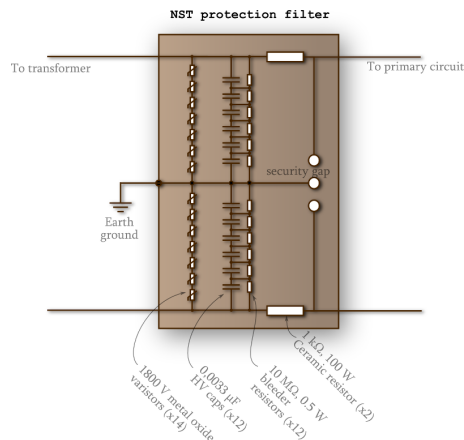

Figure 4.37: Schematic and photograph of Zeus' NST protection filter (wires not yet present).

Spark gap. It is made of three electrode (or four, a pair per side), the central one being connected to ground. If a voltage spike occurs, the gap fires and the dangerous current is redirected to ground, thus sparing the transformer.

RC low-pass filter. It is physically just behind the spark gap and is made of a 1000 Ω , 100 W ceramic resistor (technical datasheet : [55]) and of 6 high-voltage capacitors of 3.3 nF each (technical datasheet : [56]), thus totalizing 0.55 nF. Here also, bleeder resistor were soldered in parallel of each capacitor^{xiv}. At the beginning, there was an arcing problem between these resistors and the wooden support on which they lied, but a PVC support solved the issue.

The resistors cause very little energy loss as the current is very weak (25 mA rms). The average loss P is given by $P = RI^2 = 0.25$ W, which is really negligible in comparison of the 225 watts supplied. Note also that they help preventing the current flowing into the primary to come back into the transformer and beyond. Indeed, the impedance of the main spark gap firing is negligible in front of the total impedance of the NST and the filter : when it fires, it almost short-circuit these components and the high primary currents stay where they are.

In sinusoidal regime, the *cutoff frequency* of a low-pass filter is the frequency above which the transmitted intensity will be less than 0.707 ($\sqrt{1/2}$) times the input intensity [57]. One can show it is given by:

$$f_c = \frac{1}{2\pi RC} \quad (4.18)$$

We thus find the cutoff frequency to be around 287 kHz. The filter will therefore further help block the primary currents (around 320 kHz for Zeus), but more importantly, they will block the interferences of much higher frequencies (see ref. [7], Frequency splitting).

Varistors. Metal oxide varistors (MOVs) complete the protection filter. These non-linear components have their resistance drop dramatically above a certain voltage. Here, this threshold is 1800 V in direct current and 1000 V in alternating current (technical datasheet: [58]). As there are 7 of them on each side, the total threshold voltage is 7000 V. The voltage difference between a wire and the ground is 4500 V rms, so the amplitude is 6364 V, which is just below the threshold.

These components help to protect the NST from voltage spikes in case the spark gaps don't fire. Actually, they're not strictly necessary.

Ground. The central wire of this filter should *not* be connected to the safety ground. Voltage and current spikes as well as high-frequency interference would be sent, which is hazardous for electronic apparatuses connected to the mains.

A proper ground for this filter is the soil.

4.7.2 PFC capacitor

The power average over a period T of an alternating current is defined as following :

$$\langle P \rangle = \frac{1}{T} \int_0^T V(t)I(t) dt \quad (4.19)$$

where current and voltage are definition by sinusoidal functions of same frequency, but whose amplitude and phase can change. One can easily prove the next result :

$$\frac{1}{T} \int_0^T \cos(\omega t - \phi) \cos(\omega t - \psi) dt = \frac{1}{2} \cos(\phi - \psi) \quad (4.20)$$

We thus see that the power is maximum when voltage and current are in phase.

The high self-inductance of the transformer causes the current to lag the voltage, which results in less transmitted power as we just saw. To overcome this problem, i.e. re-phase both signal, one connects a capacitor in parallel to the transformer inputs. In a capacitor, it is indeed the voltage that is delayed with respect to current. This is the role of the *power factor correction capacitor* (PFC cap).

^{xiv}The same ones used in the primary capacitor, see 4.2.1 Capacitors - Cornell-Dubilier 942C.



Figure 4.38: The protection filter assembled. The NST is in the wooden box just under the filter.



Figure 4.39: Zeus' PFC cap.

This capacitor must be able to work continuously, i.e. must be a *run-type* capacitor. The *start-type* capacitors on the other side are designed to work only during short time intervals .

One can show the ideal capacitance of the PFC cap is given by [59]:

$$C_{PFC} = \frac{P}{2\pi f V_{in}^2} \quad (4.21)$$

where

P is the transformer power,

f is the mains frequency (50 Hz in Europe),

V_{in} is the mains voltage (230 V).

This yields a value of 13.54 μF for Zeus. The capacitor used is 12 μF (technical datasheet : [60]). Having the exact value doesn't matter as long as they are close enough [59].

4.7.3 AC line filter

In order to protect the electronic devices connected to the mains from dangerous transient currents/voltages and from radio interferences generated by the Tesla coil circuits, it is recommended to connect a last filter between the mains and the transformer.

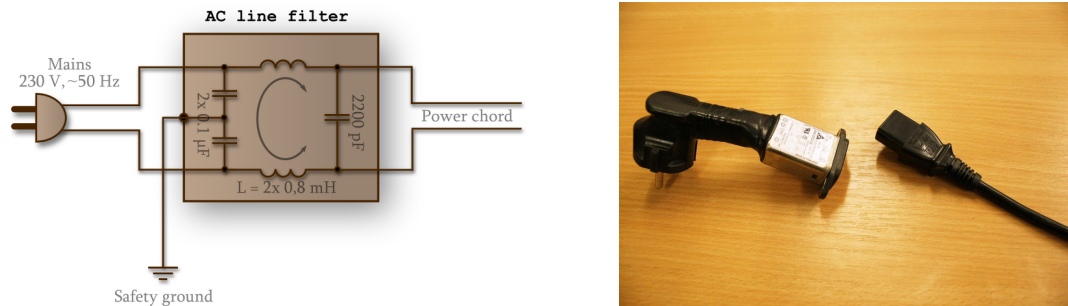

Figure 4.40: Schematic and photograph of Zeus' EMI filter.

Those interferences are normally blocked by the NST protection filter, but it is perhaps not a good idea to fully rely on a DIY component to protect the home electrical installation.

It is advised to place it as far as possible from the Tesla coil to avoid the apparition of induced current *above* the filter, hence reducing its effectiveness [61].

4.8 Last step



Figure 4.41: The machine's brass plate lies on the wooden support of the switch.

Chapter 5

Nikola Tesla, a mind ahead of its time.

This last chapter is left to Nikola Tesla, with these few quotes I find inspiring and that depicts his way of thinking.

"It is a mere question of time when men will succeed in attaching their machinery to the very wheelwork of nature."

(Experiments with Alternate Current of High Potential and High Frequency, 1892)

"The scientific man does not aim at an immediate result. He does not expect that his advanced ideas will be readily taken up. His work is like that of the planter - for the future. His duty is to lay the foundation for those who are to come, and point the way. He lives and labors and hopes."

(Radio Power Will Revolutionize the World, in Modern Mechanics and Inventions, 1934)

"I have obtained... spark discharges extending through more than one hundred feet and carrying currents of one thousand amperes, electromotive forces approximating twenty million volts, chemically active streamers covering areas of several thousand square feet, and electrical disturbances in the natural media surpassing those caused by lightning, in intensity.

Whatever the future may bring, the universal application of these great principles is fully assured, though it may be long in coming. With the opening of the first power plant, incredulity will give way to wonderment, and this to ingratitude, as ever before."

(A means for furthering peace, 1905)



Figure 5.1: Tesla reading Theoria Philosophiae Naturalis, in front of the coil of its high-frequency transformer, East Houston Street, New-York. [Photograph : Wikimedia Commons]

Appendices

Appendix A

Specifications of the Zeus Tesla coil

This appendix lists the inputs and outputs of the JAVATC simulations regarding the proprieties of the individual components.

```
J A V A T C version 13.0 - CONSOLIDATED OUTPUT  
lundi 5 mars 2012 2:08:49
```

```
Units = Centimeters  
Ambient Temp = 20 Celsius
```

```
-----  
Secondary Coil Inputs:
```

```
-----  
Current Profile = G.PROFILE_LOADED  
5 = Radius 1  
5 = Radius 2  
0 = Height 1  
40.2 = Height 2  
790 = Turns  
0.0508 = Wire Diameter
```

```
-----  
Primary Coil Inputs:
```

```
-----  
Round Primary Conductor  
7 = Radius 1  
25 = Radius 2  
0 = Height 1  
0 = Height 2  
8.25 = Turns  
1.2 = Wire Diameter  
0.01192 = Primary Cap (uF)  
30 = Total Lead Length  
0.5 = Lead Diameter
```

```
-----  
Top Load Inputs:
```

```
-----  
Toroid #1: minor=10, major=36, height=50, topload
```

```
-----  
Secondary Outputs:
```

319.46 kHz = Secondary Resonant Frequency
 90 deg = Angle of Secondary
 40.2 cm = Length of Winding
 19.65 cm = Turns Per Unit
 0.00086 mm = Space Between Turns (edge to edge)
 248.19 m = Length of Wire
 4.02:1 = H/D Aspect Ratio
 20.939 Ohms = DC Resistance
 27039 Ohms = Reactance at Resonance
 0.447 kg = Weight of Wire
 13.471 mH = Les-Effective Series Inductance
 14.185 mH = Lee-Equivalent Energy Inductance
 13.831 mH = Ldc-Low Frequency Inductance
 18.425 pF = Ces-Effective Shunt Capacitance
 17.498 pF = Cee-Equivalent Energy Capacitance
 28.809 pF = Cdc-Low Frequency Capacitance
 0.1243 mm = Skin Depth
 14.172 pF = Topload Effective Capacitance
 94.8557 Ohms = Effective AC Resistance
 285 = Q

 Primary Outputs:

317.15 kHz = Primary Resonant Frequency
 0.72 % high = Percent Detuned
 0 deg = Angle of Primary
 829.38 cm = Length of Wire
 1.26 mOhms = DC Resistance
 0.982 cm = Average spacing between turns (edge to edge)
 1.375 cm = Proximity between coils
 2.31 cm = Recommended minimum proximity between coils
 20.842 uH = Ldc-Low Frequency Inductance
 0.01175 uF = Cap size needed with Primary L (reference)
 0.284 uH = Lead Length Inductance
 74.074 uH = Lm-Mutual Inductance
 0.138 k = Coupling Coefficient
 0.129 k = Recommended Coupling Coefficient
 7.25 = Number of half cycles for energy transfer at K
 11.29 us = Time for total energy transfer (ideal quench time)

 Transformer Inputs:

230 [volts] = Transformer Rated Input Voltage
 9000 [volts] = Transformer Rated Output Voltage
 25 [mA] = Transformer Rated Output Current
 50 [Hz] = Mains Frequency
 230 [volts] = Transformer Applied Voltage

 Transformer Outputs:

225 [volt*amps] = Rated Transformer VA
 360000 [ohms] = Transformer Impedence
 9000 [rms volts] = Effective Output Voltage
 0.98 [rms amps] = Effective Transformer Primary Current
 0.025 [rms amps] = Effective Transformer Secondary Current
 225 [volt*amps] = Effective Input VA
 0.0088 [uF] = Resonant Cap Size
 0.0133 [uF] = Static gap LTR Cap Size
 0.0231 [uF] = SRSR LTR Cap Size

14 [uF] = Power Factor Cap Size
12728 [peak volts] = Voltage Across Cap
31820 [peak volts] = Recommended Cap Voltage Rating
0.97 [joules] = Primary Cap Energy
304.4 [peak amps] = Primary Instantaneous Current
55.1 [cm] = Spark Length (JF equation using Resonance Research Corp. factors)
12 [peak amps] = Sec Base Current

Static Spark Gap Inputs:

5 = Number of Electrodes
1.5 [cm] = Electrode Diameter
0.4 [cm] = Total Gap Spacing

Static Spark Gap Outputs:

0.1 [cm] = Gap Spacing Between Each Electrode
12728 [peak volts] = Charging Voltage
12450 [peak volts] = Arc Voltage
36966 [volts] = Voltage Gradient at Electrode
31125 [volts/cm] = Arc Voltage per unit
97.8 [%] = Percent Cp Charged When Gap Fires
10.09 [ms] = Time To Arc Voltage
99 [BPS] = Breaks Per Second
0.92 [joules] = Effective Cap Energy
324949 [peak volts] = Terminal Voltage
92 [power] = Energy Across Gap
58.6 [cm] = Static Gap Spark Length (using energy equation)

Program written by Barton B. Anderson ; <http://www.classictesla.com/java/javatc/javatc.html>

Appendix B

Behavior of the signal in the secondary coil

This appendix presents the results of the JAVATC simulation regarding the behavior of voltage and current as a function of height in the secondary.

Voltage and Current distribution along the length of the secondary coil.

Length	Voltage	Current
0.00	0.00	11.8
0.3	1755.8	11.9
1	5815.6	11.9
2.5	15548.3	12
4	26395.5	12
5.4	37913.8	12
6.9	49857.5	12
8.4	62077.7	12
9.8	74477.9	12
11.3	86992.7	11.9
12.8	99575.5	11.9
14.2	112191.4	11.9
15.7	124813	11.8
17.2	137417.8	11.8
18.6	149986.4	11.7
20.1	162501.6	11.7
21.6	174947.2	11.6
23	187307.6	11.5
24.5	199566.7	11.4
26	211707.5	11.3
27.4	223710.5	11.2
28.9	235553.2	11.1
30.4	247206.9	11
31.8	258633.7	10.9
33.3	269780.3	10.8
34.8	280567.8	10.7
36.2	290872.9	10.5
37.7	300491.1	10.4
39.2	309046	10.3
39.9	312588.3	10.1
40.2	314120.8	10

Program written by Barton B. Anderson ; <http://www.classictesla.com/java/javatc/javatc.html>

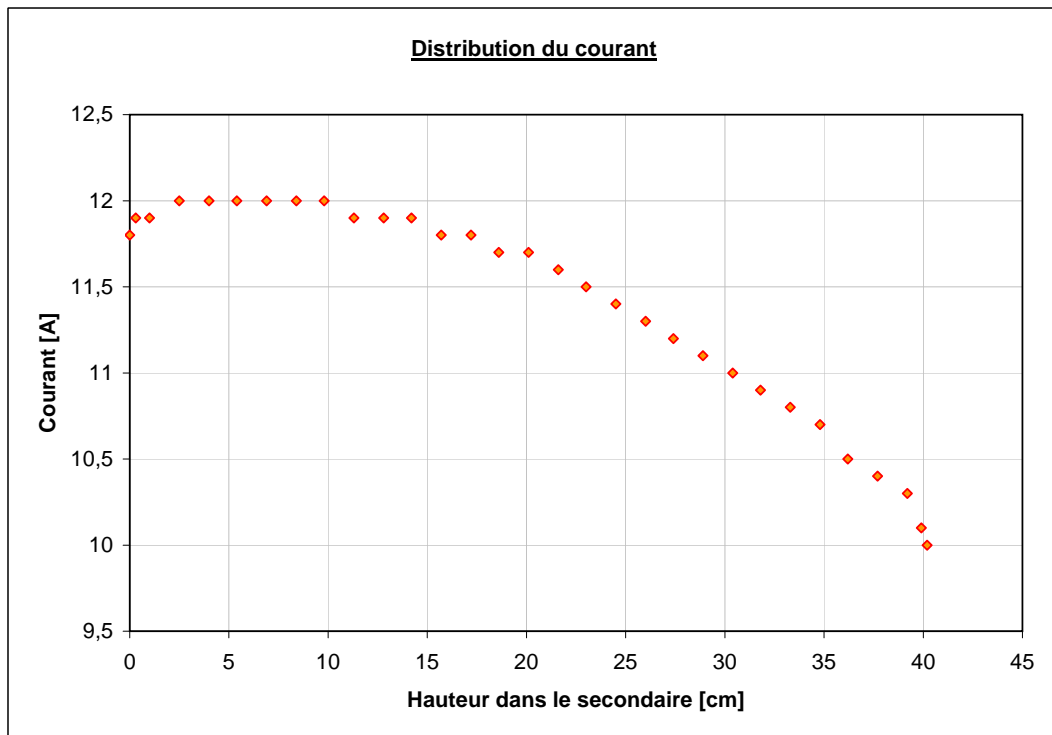
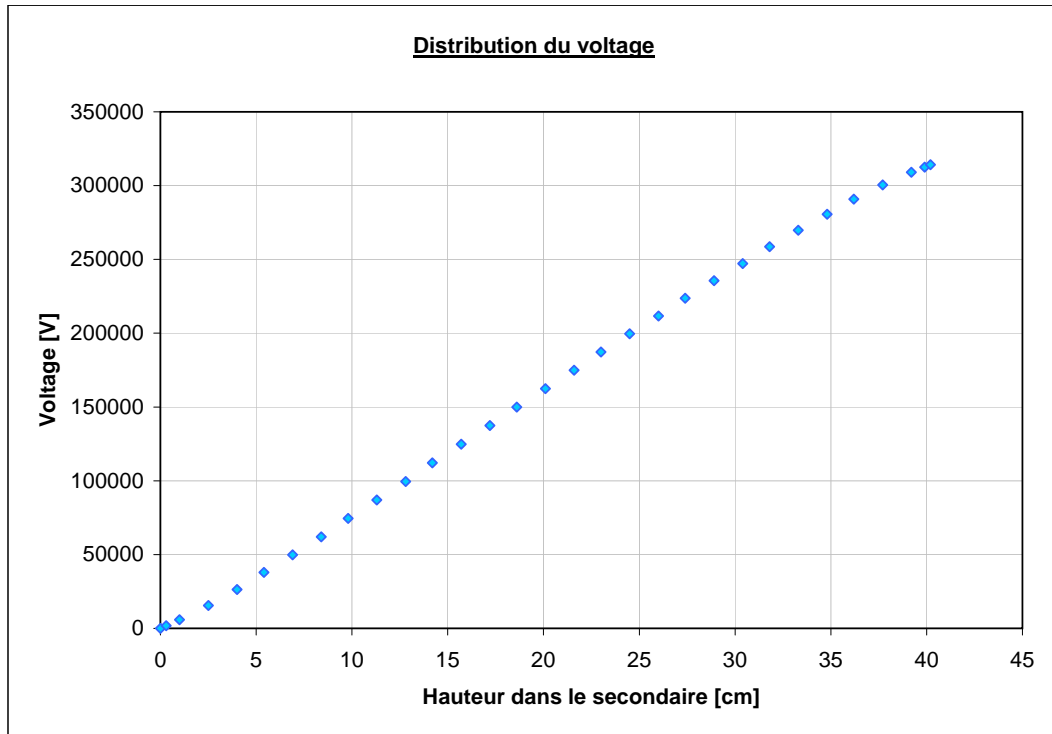

Figure B.1: Plots of the previous values.

Appendix C

Analysis of the RLC circuit

We propose here to make a quick mathematical analysis of the series RLC circuit with a sinusoidal voltage generator, like the one on the next figure. We will make more precise some of the qualitative explanations of section 3.2.3, and also generalize the results obtained for the LC circuit.

The equation describing this system is different from equation (3.24) of the LC circuit because of the added resistor R . The tension across the leads is given by Ohm's law (3.1) $V = RI$. Using Kirchoff's law for currents, we know that the current $I(t)$ is identical in the entire loop. We then have :

$$L\dot{I} + RI + \frac{1}{C} \int I dt = V_0 \sin \Omega t \quad (C.1)$$

or in a equivalent way :

$$L\ddot{Q} + R\dot{Q} + \frac{1}{C}Q = V_0 \sin \Omega t \quad (C.2)$$

where we used the relation $I = \frac{dQ}{dt}$.

Underdamped case : $0 < \frac{R}{2L} < \frac{1}{\sqrt{LC}}$.

Homogeneous solution. We first look at the situation where there's no driving force. We begin by setting the following two quantities, which both have the dimensions of an angular speed :

$$\begin{aligned} \alpha &= \frac{R}{2L} \\ \omega &= \frac{1}{\sqrt{LC}} \end{aligned} \quad (C.3)$$

Equation (C.2) thus reads

$$\ddot{Q} + 2\alpha\dot{Q} + \omega^2 Q = 0 \quad (C.4)$$

By resolving this equation with the characteristic polynomial method, one finds :

$$\begin{aligned} Q_h(t) &= e^{-\alpha t} \left[Q_0 \cos \hat{\omega} t + \left(\frac{I_0 + Q_0 \alpha}{\hat{\omega}} \right) \sin \hat{\omega} t \right] \\ &\text{with } \hat{\omega} = \sqrt{\omega^2 - \alpha^2} \end{aligned} \quad (C.5)$$

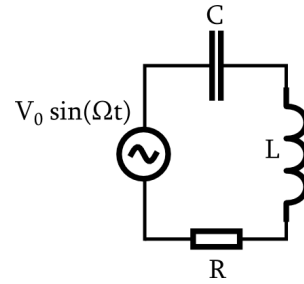

where Q_0 and I_0 respectively represent the charge and the current at the initial moment $t = 0$.

In this free regime, we see that the system carries out *oscillations whose amplitude exponentially decrease with time*, conversely to the LC circuit where the oscillation amplitude stays constant. We also remark that the natural pulsation of the oscillations $\hat{\omega}$ has "shifted" from the LC's one (page 9), which was $\omega = 1/\sqrt{LC}$. Finally, we notice that at the limit where the attenuation term α goes to 0, we recover the solution for the LC circuit (formula (3.22), where we moreover set $I_0 = 0$).

One finds the current $I(t)$ by derivating (C.5) with respect to time.

General solution. One can verify that the following function is indeed a particular solution to (C.1) :

$$Q_p(t) = V_0 \frac{-2\alpha\Omega \sin \Omega t + (\omega^2 - \Omega^2) \cos \Omega t}{(\omega^2 - \Omega^2)^2 + 4\Omega^2\alpha^2} \quad (\text{C.6})$$

The general solution is therefore :

$$Q(t) = e^{-\alpha t} \left[Q_0 \cos \hat{\omega} t + \left(\frac{I_0 + Q_0\alpha}{\hat{\omega}} \right) \sin \hat{\omega} t \right] + V_0 \frac{-2\alpha\Omega \sin \Omega t + (\omega^2 - \Omega^2) \cos \Omega t}{(\omega^2 - \Omega^2)^2 + 4\Omega^2\alpha^2} \quad (\text{C.7})$$

Here we see that the term $4\Omega^2\alpha^2$ prevents the asymptotic behavior encountered in the LC circuit when $\Omega = \omega$: Oscillations remain bounded no matter what in an RLC circuit. This explains the differences between Figs. 3.9 and 3.11. An important thing to note is that, beside the frequency of the free oscillations of an RLC circuit $\hat{\omega} = \sqrt{\omega^2 - \alpha^2}$ is different from the LC circuit, *the resonant frequency in driven regime remains the same* : the last term of (C.7) is maximal when $\Omega = \omega$ and not $\hat{\omega}$. This is why the results on resonant frequency derived for the unrealistic LC circuit still holds for Tesla coil circuits.

Current $I(t)$ can be found by time-derivating (C.7).

Overdamped case $0 < \frac{1}{\sqrt{LC}} < \frac{R}{2L}$.

Now the attenuation term α is greater than the oscillating term ω , the discriminant of the characteristic polynomial of (C.1) is positive and the solution is a sum of real exponentials instead of imaginary ones. The particular solution (C.6) is unaffected by this change however. Let's directly write down the general solution then :

$$Q(t) = e^{-\alpha t} \left[Q_0 \cosh \hat{\omega} t + \left(\frac{I_0 + Q_0\alpha}{\hat{\omega}} \right) \sinh \hat{\omega} t \right] + V_0 \frac{-2\alpha\Omega \sin \Omega t + (\omega^2 - \Omega^2) \cos \Omega t}{(\omega^2 - \Omega^2)^2 + 4\Omega^2\alpha^2} \quad (\text{C.8})$$

The only oscillations the circuit executes come from the driving force, without which no oscillations would take place.

Case where $\frac{1}{\sqrt{LC}} = \frac{R}{2L}$.

There is in theory a third situation, said to be *critically damped*, that account for $\frac{1}{\sqrt{LC}} = \frac{R}{2L}$. This intermediate situation is very rare in practice. The characteristic polynomial has an unique root and the homogeneous solution thus reads:

$$Q_h(t) = (K_1 + K_2 t) e^{-\omega t} \quad (\text{C.9})$$

where K_1 et K_2 are integration constants than can be determined in terms of the initial conditions.

See also

- Ron Cummings, College of the Redwoods, *RLC Circuit*, 1997,
<http://online.redwoods.cc.ca.us/instruct/darnold/deproj/Sp97/Ron/ronproj.pdf>.

Appendix D

Analysis of two inductively coupled oscillating circuits.

Let's make a short analysis of the system made of two inductively coupled oscillating circuits. We'll first deal with two coupled LC circuits, and then two RLC circuits. The goal is to look at the differential equations that describe the behavior of the Tesla coil itself relatively well.

We will only look at the homogeneous cases, as when the spark gap fires, the alternating voltage generator (i.e. the transformer) is almost short-circuited.

D.1 Two coupled LC circuits

We're about to analyze the circuit represented in the next picture, which is identical to an ideal Tesla coil with spark gap closed (Fig. 3.13). The self-inductance and capacitance of the primary circuit are respectively L_1 and C_1 while those of the secondary are L_2 and C_2 . The mutual inductance between the circuits is denoted M .

Kirchoff's law for current tells that the current is identical in the primary loop, we'll note it I_1 . Same thing with the current flowing within the secondary loop, I_2 ¹.

Using the differential expressions of the components, the equation system describing the present circuit is the following :

$$\begin{cases} L_1 \dot{I}_1 + M \dot{I}_2 + \frac{1}{C_1} \int I_1 dt = 0 \\ L_2 \dot{I}_2 + M \dot{I}_1 + \frac{1}{C_2} \int I_2 dt = 0 \end{cases} \quad (\text{D.1})$$

which we rewrite in a nicer form:

$$\begin{cases} L_1 \ddot{Q}_1 + M \ddot{Q}_2 + \frac{1}{C_1} Q_1 = 0 \\ L_2 \ddot{Q}_2 + M \ddot{Q}_1 + \frac{1}{C_2} Q_2 = 0 \end{cases} \quad (\text{D.2})$$

¹In theory, we know that the conventional Kirchoff's laws won't apply here, as the dimensions of the secondary circuit is not negligible comparing to the signal wavelength, but the results we'll derive, assuming they hold, will nevertheless give a good idea of what's happening in a Tesla coil.

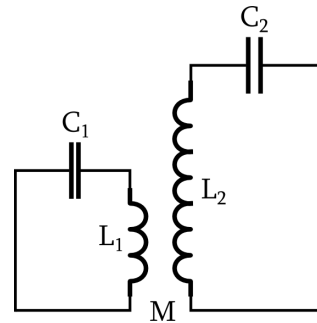

We'll resolve this system with the following initial conditions :

$$\begin{aligned} Q_1(0) &= Q, \quad \dot{Q}_1(0) = 0 \\ Q_2(0) &= 0, \quad \dot{Q}_2(0) = 0 \end{aligned} \quad (\text{D.3})$$

which correspond to the situation where only the primary capacitor is charged ($Q = C_1V$, without any other charge or current elsewhere in the circuits, just like in a Tesla coil). Solving the system with a commercially available math software, we get

$$Q_1(t) = \frac{Q}{4\omega^2} e^{-(u+v)t} \left[(\omega_1^2 - \omega_2^2 + \omega^2) (e^{ut} + e^{(u+2v)t}) + (-\omega_1^2 + \omega_2^2 + \omega^2) (e^{vt} + e^{(2u+v)t}) \right] \quad (\text{D.4})$$

$$Q_2(t) = \frac{Qk^2}{2C_1\omega^2} [e^{-ut} + e^{ut} - (e^{-vt} + e^{vt})] \quad (\text{D.5})$$

where we've replaced the following quantities :

$$k = \frac{M}{\sqrt{L_1 L_2}} \quad (\text{D.6})$$

$$\omega_i = \frac{1}{\sqrt{L_i C_i}} \quad (i = 1, 2) \quad (\text{D.7})$$

$$\omega^2 = \sqrt{\omega_1^4 + \omega_2^4 + 2\omega_1^2\omega_2^2(2k^2 - 1)} \quad (\text{D.8})$$

$$u = \sqrt{\frac{\omega_1^2 + \omega_2^2 - \omega^2}{2(k^2 - 1)}} \quad (\text{D.9})$$

$$v = \sqrt{\frac{\omega_1^2 + \omega_2^2 + \omega^2}{2(k^2 - 1)}} \quad (\text{D.10})$$

k is the *coupling constant* binding the primary and secondary circuits (we've talked about it in [3.3.5 Influence of the coupling](#)) ; we immediately check it is a dimensionless quantity. It can be shown that :

$$0 < k < 1 \quad (\text{D.11})$$

The case $k = 0$ is meaningless/irrelevant here as it implies the two circuits aren't interacting and the case $k = 1$ is never physically attained.

ω_1 and ω_2 respectively represent the resonant pulsation of the primary and secondary circuit. ω has thus also the dimensions of a pulsation. Moreover, because of (D.11),

$$\omega^2 < \sqrt{\omega_1^4 + \omega_2^4 + 2\omega_1^2\omega_2^2} \quad (\text{D.12})$$

$$< \omega_1^2 + \omega_2^2 \quad (\text{D.13})$$

u et v also have the dimensions of a pulsation. We can also see they are actually purely imaginary quantities. Indeed, the numerator is positive and both constant while the denominator is always negative (because of (D.11) again). We can thus rewrite as follows :

$$u = -i \sqrt{\frac{\omega_1^2 + \omega_2^2 - \omega^2}{2(1 - k^2)}} \quad (\text{D.14})$$

$$v = -i \sqrt{\frac{\omega_1^2 + \omega_2^2 + \omega^2}{2(1 - k^2)}} \quad (\text{D.15})$$

We therefore deduce the expression (D.4) and (D.5) to be *oscillating solutions*, as sums of imaginary exponentials.

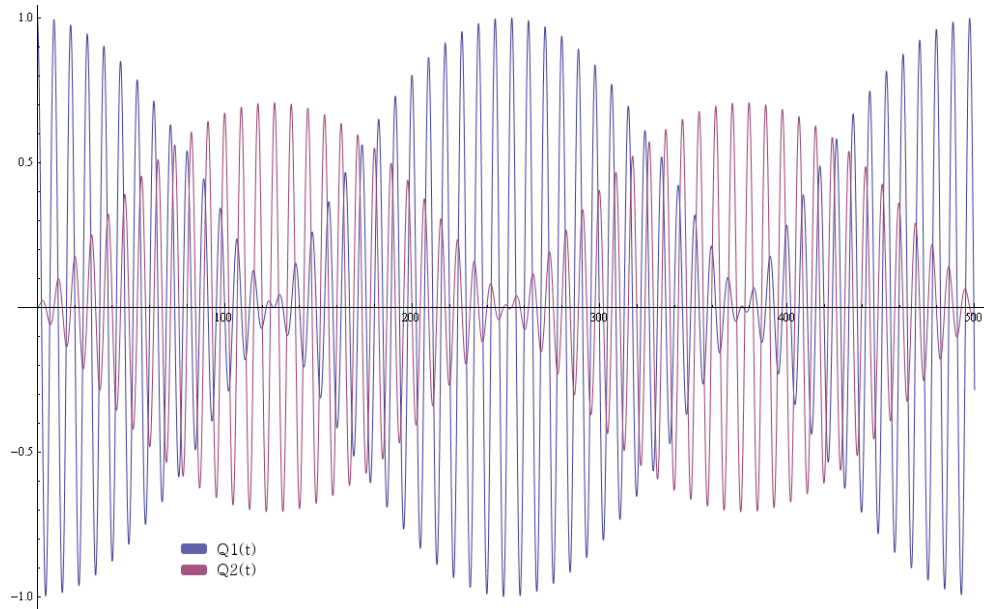

Figure D.1: Plots of $Q_1(t)$ and $Q_2(t)$ for two inductively coupled LC circuits with $Q = 1$; $\omega_1 = \omega_2 = 0.5$; $\frac{M}{L_1} = 0.05$; $\frac{M}{L_2} = 0.025$.

Solution for $\omega_1 = \omega_2$.

We've made no hypothesis on the circuits so far. We'll now look at the case when both circuits are at resonance, just as in a Tesla coil. When $\omega_1 = \omega_2$, the functions obtained become less gory and easier to physically interpret.

We thus get :

$$\omega^2 = 2k\omega_2^2 \quad (\text{D.16})$$

$$u = i \frac{\omega_2}{\sqrt{1+k}} \equiv i\tilde{u} \quad (\text{D.17})$$

$$v = -i \frac{\omega_2}{\sqrt{1-k}} \equiv i\tilde{v} \quad (\text{D.18})$$

Solutions (D.4) et (D.5) then become

$$Q_1(t) = \frac{Q}{4} \left[e^{-ut} + e^{ut} + e^{-vt} + e^{vt} \right] \quad (\text{D.19})$$

$$Q_2(t) = \frac{Qk}{4C_1\omega_2^2} \left[e^{-ut} + e^{ut} - (e^{-vt} + e^{vt}) \right] \quad (\text{D.20})$$

If coupling is weak, i.e. $k \ll 1$, \tilde{u} is close to \tilde{v} and we have $(\tilde{u} - \tilde{v}) \ll (\tilde{u} + \tilde{v})$. We can easily see that

expressions (D.19) and (D.20) represent a *beat*. Indeed, applying Euler's formula, we get :

$$Q_1(t) = \frac{Q}{4} [\cos \tilde{u}t + \cos \tilde{v}t] \quad (\text{D.21})$$

$$= \frac{Q}{2} \left[\cos \left(\frac{\tilde{u} + \tilde{v}}{2} t \right) \cos \left(\frac{\tilde{u} - \tilde{v}}{2} t \right) \right] \quad (\text{D.22})$$

$$Q_2(t) = \frac{Qk}{4C_1\omega_2^2} [\cos \tilde{u}t - \cos \tilde{v}t] \quad (\text{D.23})$$

$$= \frac{-Qk}{2C_1\omega_2^2} \left[\sin \left(\frac{\tilde{u} + \tilde{v}}{2} t \right) \sin \left(\frac{\tilde{u} - \tilde{v}}{2} t \right) \right] \quad (\text{D.24})$$

The plots of $Q_1(t)$ and $Q_2(t)$ shown in Fig. D.1 above indeed correspond to what we expected. The only difference with Fig. 3.20 (page 18) is the absence of exponential decrease of the envelop. This is because we considered LC circuits, where resistance is zero.

D.2 Two coupled RLC circuits

Now we consider the resistance of both circuits to be non-zero and represent it by a lumped resistor in series. The circuits we'll deal with are shown in next picture. Like previously, we call I_1 the current flowing in the primary circuit and I_2 the one flowing in the secondary.

Using the differential expression of the component, the equation system describing this circuit is the following :

$$\begin{cases} L_1 \dot{I}_1 + M \dot{I}_2 + R_1 I_1 + \frac{1}{C_1} \int I_1 dt = 0 \\ L_2 \dot{I}_2 + M \dot{I}_1 + R_2 I_2 + \frac{1}{C_2} \int I_2 dt = 0 \end{cases} \quad (\text{D.25})$$

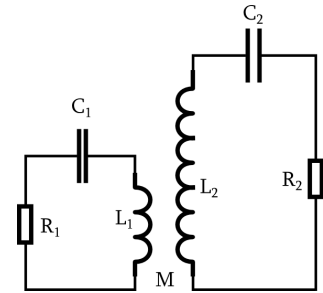

or, in term of the charge in the capacitors :

$$\begin{cases} L_1 \ddot{Q}_1 + M \ddot{Q}_2 + R_1 \dot{Q}_1 + \frac{1}{C_1} Q_1 = 0 \\ L_2 \ddot{Q}_2 + M \ddot{Q}_1 + R_2 \dot{Q}_2 + \frac{1}{C_2} Q_2 = 0 \end{cases} \quad (\text{D.26})$$

Actually, this system has no analytic solution in the general case (see article below), even when we consider the circuits to be at resonance. The system thus has to be resolved *numerically*.

After implementing the aforementioned system in a computing software with initials conditions (D.3) like previously, we get the functions that have been plotted in Fig. D.2.

The influence of the resistors has been exaggerated in order to emphasize their effects. We thus see that, beside the exponential decrease of the envelops, the new terms in the first time-derivative of the charge deform the envelops shape and also shift them with respect to each other : the primary nodes no longer exactly coincide with the secondary antinodes and vice-versa. The shift between the secondary node and the primary antinode is however less obvious because we considered the primary resistance to be much lower than the secondary. In a real Tesla coil, much of the energy dissipation indeed occurs within the secondary.

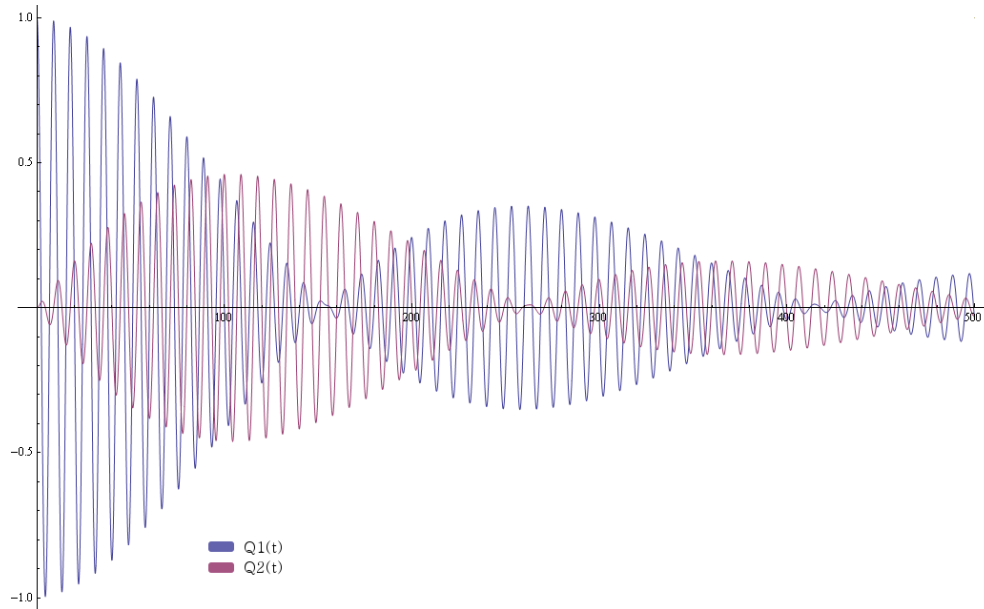

Figure D.2: Plots of $Q_1(t)$ et $Q_2(t)$ for two inductively coupled RLC circuits with $Q = 1$; $\omega_1 = \omega_2 = 0.5$; $\frac{M}{L_1} = 0.05$; $\frac{M}{L_2} = 0.025$; $\frac{R_1}{L_1} = 0.001$; $\frac{R_2}{L_2} = 0.015$.

See also

- Marco Denicolai, *Optimal performances for tesla transformers*, Review of scientific instruments 73, Number 9 September 2002,
http://rsi.aip.org/resource/1/rsinak/v73/i9/p3332_s1.

References

- [1] English Wikipedia. *Nikola Tesla*, http://en.wikipedia.org/wiki/Nikola_Tesla, retrieved on 01/02/12.
- [2] English Wikipedia. *LC circuit*, http://en.wikipedia.org/wiki/Lc_circuit, retrieved on 02/02/12.
- [3] Joel Feldman, Mathematics Department, University of British Columbia. *The RLC Circuit*, www.math.ubc.ca/~feldman/m101/RLC.pdf
- [4] Harvey Mudd College, Engineering Department. *Series and Parallel Resonance*, <http://fourier.eng.hmc.edu/e84/lectures/ch3/node8.html>, retrieved on 03/02/12.
- [5] TechLib. *Q-factor*, <http://www.techlib.com/reference/q.htm>, retrieved on 03/02/12.
- [6] All About Circuits. *Q and bandwidth of a resonant circuit*, http://www.allaboutcircuits.com/vol_2/chpt_6/6.html, retrieved on 03/02/12.
- [7] Richard Burnett. *Operation of the Tesla Coil*, <http://www.richieburnett.co.uk/operation.html> et <http://www.richieburnett.co.uk/operatn2.html>
- [8] Matt Behrend. *How a Tesla Coil works*, <http://tayloredge.com/reference/Machines/TeslaCoil.pdf>
- [9] Herbert Mehlhose. *Herb's Tesla Coil Page*, http://home.wtal.de/herbs_teslapage/design.html
- [10] Marco Denicolai. *Tesla Transformer for Experimentation and Research*, <http://www.saunalahti.fi/dnmcrc1/lthesis.pdf>
- [11] Marco Denicolai. *Tesla coil tuning*, <http://www.saunalahti.fi/dnmcrc1/tuning.zip>
- [12] Jamie Oliver. *The Coil in a "Magnifier" Vs. Conventional configuration*, <http://www.frontiernet.net/~tesla/html/magnifier.html>
- [13] Kevin Wilson. *Top Load*, <http://www.teslacoildesign.com/#topload>
- [14] Phillip Tuck. *Tuning*, <http://www.hvtesla.com/tuning.html>
- [15] Ronold W. P. King, Harry Rowe Mimno, Alexander H. Wing. *Transmission lines, Antennas and Wave guides* (McGraw-Hill 1945).
- [16] All About Circuits. *Standing waves and resonance*, http://www.allaboutcircuits.com/vol_2/chpt_14/6.html, retrieved on 14/02/12.
- [17] Terry Firtz. *An Analysis of Top and Bottom Currents in the Tesla Coil Secondary Inductor.*, <http://www.classictesla.com/hot-streamer/TeslaCoils/MyPapers/topsync/topsync.html>

- [18] Bart Anderson. *JAVATC*, <http://www.classictesla.com/java/javatc/javatc.html>
- [19] Bart Anderson. *JAVATC - Spark length*, <http://www.classictesla.com/java/script/stg11.html>, <http://www.classictesla.com/java/script/xo12.html>.
- [20] Richard Burnett. *Resonant charging*, <http://www.richieburnett.co.uk/resonant.html#resonant1>
- [21] Kevin Wilson. *Primary Capacitors (MMC)*, <http://www.teslacoildesign.com/#primarycapacitors>
- [22] Quad Tech Application note. *Equivalent series resistance (ESR) of capacitors*, www.low-esr.com/QT_LowESR.pdf
- [23] Radio-Electronics. *Capacitor ESR, Dissipation Factor, Loss Tangent and Q*, <http://www.radio-electronics.com/info/data/capacitor/esr-df-loss-tangent-q-tutorial-basics.php>
- [24] The Physics Factbook. *Dielectric Strength of Polyethylene*, <http://hypertextbook.com/facts/2009/CherryXu.shtml>
- [25] Wolfram|Alpha. <http://www.wolframalpha.com/>
- [26] English Wikipedia. *Dielectric strength*, http://en.wikipedia.org/wiki/Dielectric_strength, retrieved on 17/02/12.
- [27] Steeve Bell. *DeepFriedNeon - Coil Components*, http://deepfriedneon.com/tesla_frame3.html
- [28] Herbert Mehlhose. *My Coil Page*, http://home.wtal.de/herbs_teslapage/mycoil.html#my-2cap
- [29] Jochen Kronjaeger. *Plate stack capacitor*, <http://www.kronjaeger.com/hv/hv/comp/cap/caps.html#stack>
- [30] Cornell Dubiler Electronics. *Type 942C, Polypropylene Capacitors, for High Pulse, Snubber*, <http://www.cde.com/catalogs/942C.pdf>
- [31] Terry Firtz. *Lifetime of CD942C20P15K is ≈ 75 hours*, <http://www.pupman.com/listarchives/2005/Sep/msg00917.html>
- [32] Carbon Film Resistors *General Type ; Normal & Miniature Style [CFR Series]*, http://www.yageo.com/documents/recent/Leaded-R_CFR_2011.pdf
- [33] Ohmite Mfg. Co. *TEH100 Series*, <http://www.ohmite.com/catalog/pdf/teh100.pdf>
- [34] Kevin Wilson. *Calculations*, <http://www.teslacoildesign.com/#calculations>
- [35] Kevin Wilson. *Primary Coil*, <http://www.teslacoildesign.com/#primarycoil>
- [36] English Wikipedia. *Skin effect*, http://en.wikipedia.org/wiki/Skin_effect, retrieved on 22/02/12.
- [37] Richard Burnett. *Static spark gap analysis*, <http://www.richieburnett.co.uk/static.html>
- [38] The Physics Factbook. *Dielectric Strength of Air*, <http://hypertextbook.com/facts/2000/AliceHong.shtml>
- [39] Philip Tuck. *'Sucker spark gap' Mk 2*, http://www.hvtesla.com/sucker_gap.html

- [40] Kevin Wilson. *Spark Gap*, <http://www.teslacoildesign.com/#sparkgap>
- [41] Altair. *The Altair Flexigap*, <http://www.altair.org/projects/flexigap.gif>
- [42] Bart Anderson. *JAVATC - Fraga AC Resistance*, <http://www.classictesla.com/java/javatc/script/outRac.html>
- [43] Bart Anderson. *JAVATC - Effective Series Inductance*, <http://www.classictesla.com/java/javatc/script/out9.html>
- [44] Bart Anderson. *JAVATC - Effective Shunt Capacitance*, <http://www.classictesla.com/java/javatc/script/out12.html>
- [45] Bart Anderson. *JAVATC - Q factor*, <http://www.classictesla.com/java/javatc/script/outQ.html>
- [46] Kevin Wilson. *Secondary Coil*, <http://www.teslacoildesign.com/#secondarycoil>
- [47] Bart Anderson. *JAVATC - H/D Aspect Ratio*, <http://www.classictesla.com/java/javatc/script/out5.html>
- [48] Richard Brunett. *Tesla coil components - Toroid*, <http://www.richieburnett.co.uk/parts2.html#toroid>
- [49] Philip Tuck. *A new 8.5 x 34.5 Toroid for the 'Phoenix'*, http://www.hvtesla.com/toroid_2.html
- [50] Jamie Oliver. *How to tune a Tesla coil*, <http://www.frontiernet.net/~tesla/html/tuneacoil.htm>
- [51] Tesla's Legacy. *Oscilloscope tuning for Tesla coil resonance*, <http://www.hvtesla.com/tuning.html>
- [52] Kevin Wilson. *Grounding*, <http://www.teslacoildesign.com/#grounding>
- [53] Kevin Wilson. *NST filter protection*, <http://www.teslacoildesign.com/#nstprotection>
- [54] Philip Tuck. *The Terry Filter*, <http://www.hvtesla.com/terry.html>
- [55] Ohmite Mfg. Co. *270 Series*, http://www.ohmite.com/catalog/pdf/270_series.pdf
- [56] Panasonic. *ECWH(V) Series*, <http://industrial.panasonic.com/www-cgi/jvcr13pz.cgi?E+PZ+3+ABD0025+ECWH16332JV+7+WW>
- [57] All About Circuits. *Low-pass filters*, http://www.allaboutcircuits.com/vol_2/chpt_8/2.html,
retrived on 10/03/12.
- [58] Panasonic. *"ZNR" Transient/surge absorbers*, <http://industrial.panasonic.com/www-data/pdf/AWA0000/AWA0000CE2.pdf>
- [59] Kevin Wilson. *PFC capacitors*, <http://www.teslacoildesign.com/#pfccapacitors>
- [60] Panasonic. *PMF Series*, <http://media.digikey.com/pdf/Data%20Sheets/Panasonic%20Capacitors%20PDFs/SPU25%20DRY%20FILM%20CAP%20250V.pdf>
- [61] Kevin Wilson. *Line filters*, <http://www.teslacoildesign.com/#linefilters>

Bibliography

Nikola Tesla's Patent

- Nikola Tesla, *Apparatus for transmitting electrical energy*. US Patent n° 1119732 (US Patents Office, 1914). Online on *Google Patents* :
<http://www.google.com/patents?vid=1119732>

Thesis's and reports

- Marco Denicolai, *Tesla Transformer for Experimentation and Research*.
<http://www.saunalahti.fi/dncmrc1/lthesis.pdf>
- United States Navy (USN), *VLF/LF High-Voltage Design and Testing*.
<http://www.dtic.mil/dtic/tr/fulltext/u2/a526052.pdf>
- Matt Behrend, *How a Tesla Coil works*.
<http://tayloredge.com/reference/Machines/TeslaCoil.pdf>

Books

- Mitch Tilbury, *The Ultimate Tesla Coil Design and Construction Guide* (McGraw-Hill, 2008). Online on *issuu* :
http://issuu.com/theresistance/docs/-np--the-ultimate-tesla-coil-desig_20101219_062111

Websites

- Tesla coil Design, Contruction and Operation Guide -Kevin Wilson.
<http://www.teslacoildesign.com>
Complete explanations of all the components of a Tesla coil, an excellent reference.
- Richard Burnett's Tesla Coil Webpage.
<http://www.richieburnett.co.uk/tesla.shtml>
Theory and analysis of the component. The best reference when it comes to theory of operation
- Classic Tesla -Bart Anderson.
<http://www.classictesla.com>
Includes a Java spreadsheet making all the computations rigorously.

- Tesla's Legacy -Philip Tuck.
<http://www.hvtesla.com/index.html>
Very good material on theory and construction.
- Herb's Tesla Coil Page.
http://home.wtal.de/herbs_teslapage/index.html
Detailed explanations about construction (including how to make homemade capacitors).
- DeepFriedNeon -Steve Bell.
http://deepfriedneon.com/tesla_frame0.html
Helpful website on construction.
- Tesla Coil Mailing List.
<http://www.pupman.com>
Ask the Tesla coil experts! Also includes archives of all older threads.
- Tesla Coil Grounding -Jim Lux.
<http://home.earthlink.net/~jimlux/hv/tcground.htm>
How to properly ground a Tesla coil.
- Jochen's High Voltage Page, Capacitors.
<http://www.kronjaeger.com/hv/hv/comp/cap/index.html>
Details on how to make homemade capacitors.