

## **The Ultimate Vector Kinematics Assignment (9%)**

9401

1.

Which one of the following is a vector quantity?

- A. time
- B. speed
- C. energy
- D. displacement

2.

A car is travelling at a constant speed of 26.0 m/s down a slope which is  $12.0^\circ$  to the horizontal. What is the vertical component of the car's velocity?

- A. 5.41 m/s
- B. 9.80 m/s
- C. 25.4 m/s
- D. 26.0 m/s

3.

A 1.50 kg projectile is launched at 18.0 m/s from level ground. The launch angle is  $26.0^\circ$  above the horizontal. (Assume negligible friction.)

a) What is the maximum height reached by this projectile? **(5 marks)**

How fast will the projectile be travelling when it is at its maximum height? **(2 marks)**

9501

4.

Initial velocity vector  $\vec{V}_0$  and final velocity vector  $\vec{V}$  are shown below.

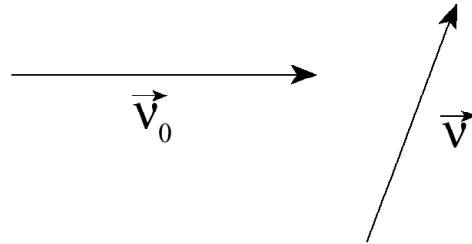

Which of the following represents the change in velocity  $\Delta\vec{V}$ ?

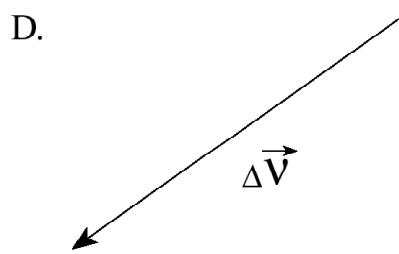
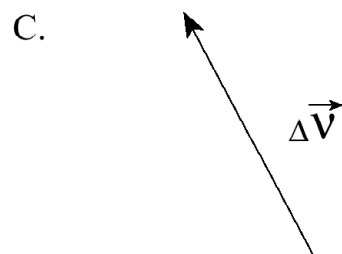
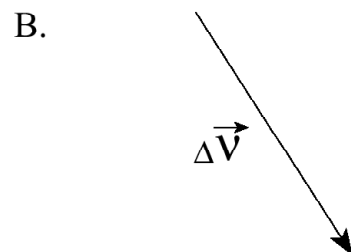
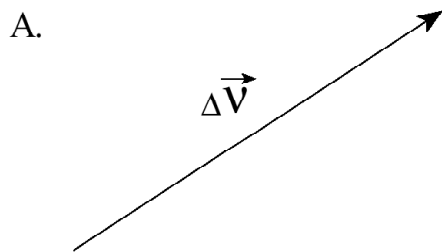

5.

A projectile is launched over level ground with a speed of 240 m/s at  $35^\circ$  to the horizontal. If friction is negligible, what is the height of the projectile 17 s after launch?

- A.  $9.2 \times 10^2$  m
- B.  $1.9 \times 10^3$  m
- C.  $2.7 \times 10^3$  m
- D.  $5.5 \times 10^3$  m

Physics 12  
Unit 1 Kinematics

9506

6.

A passenger jet needs to reach a speed of 100 m/s on the runway for takeoff. If the runway is  $2.5 \times 10^3$  m long, what minimum average acceleration from rest is needed?

- A.  $0.040 \text{ m/s}^2$
- B.  $2.0 \text{ m/s}^2$
- C.  $4.0 \text{ m/s}^2$
- D.  $10 \text{ m/s}^2$

7.

The diagram below shows projectile motion in the absence of friction.

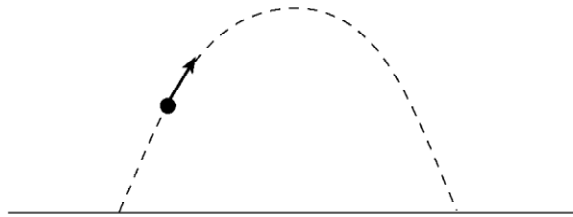

This motion can be analyzed in terms of horizontal and vertical velocity components. Explain the behavior of these velocity components, using principles of physics. **(4 marks)**

---

---

---

---

---

---

---

---

---

---

9508

8.

At what speed must a ball be thrown upwards to reach a maximum height of 25 m?

- A. 2.6 m/s
- B. 22 m/s
- C.  $2.5 \times 10^2$  m/s
- D.  $3.1 \times 10^3$  m/s

Physics 12  
Unit 1 Kinematics

9.

A projectile is launched over level ground at 35 m/s at an angle of  $24^\circ$  above the horizontal. Friction is negligible.

a) What is the time of flight of this projectile? **(3 marks)**

What is the velocity (magnitude and direction) of this projectile 2.5 s after launch? **(4 marks)**

9601

10.

Which of the following graphs represents the horizontal velocity component ( $v_x$ ) versus time for a projectile thrown horizontally off a cliff? (Ignore air resistance.)

A.

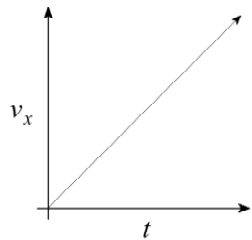

B.

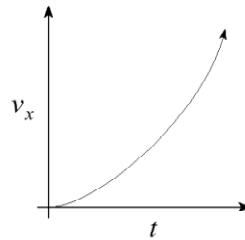

C.

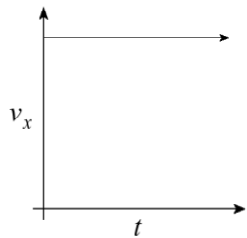

D.

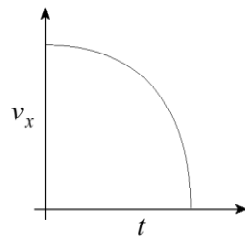

Physics 12  
Unit 1 Kinematics

11.

A skier accelerates uniformly from  $5.2 \text{ m/s}$  to  $12.8 \text{ m/s}$  at  $0.85 \text{ m/s}^2$ . Find the distance she travels.

- A.  $7.7 \text{ m}$
- B.  $8.9 \text{ m}$
- C.  $11 \text{ m}$
- D.  $80 \text{ m}$

12.

A projectile is launched over level ground at  $35 \text{ m/s}$  at an angle of  $40^\circ$  above the horizontal. What is the projectile's time of flight?

- A.  $2.3 \text{ s}$
- B.  $4.6 \text{ s}$
- C.  $5.5 \text{ s}$
- D.  $7.1 \text{ s}$

13.

A boat which can travel at  $5.6 \text{ m/s}$  in still water heads due east across a river from a dock at X. The boat's resultant path is  $32^\circ$  south of east.

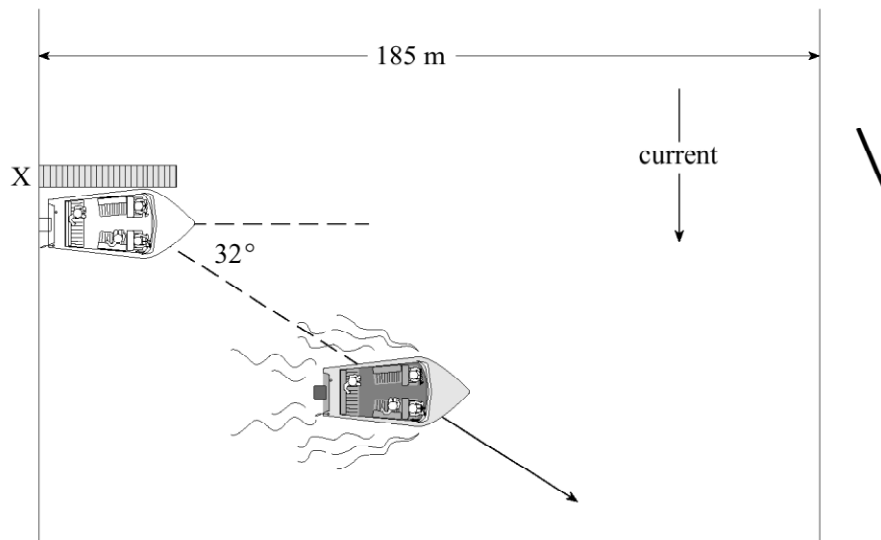

a) What is the speed of the current? (5 marks)

b) How long will it take the boat to reach the far shore if the river is  $185 \text{ m}$  wide? (2 marks)

Physics 12  
Unit 1 Kinematics

9606

14.

Which of the following remain(s) constant for a projectile: its horizontal velocity component,  $v_H$ , its vertical velocity component,  $v_V$ , its vertical acceleration,  $g$ ?

- A.  $v_V$
- B.  $g$  and  $v_V$
- C.  $g$  and  $v_H$
- D.  $g$ ,  $v_H$  and  $v_V$

15.

A pilot points an aircraft due east, while the wind blows from the south.

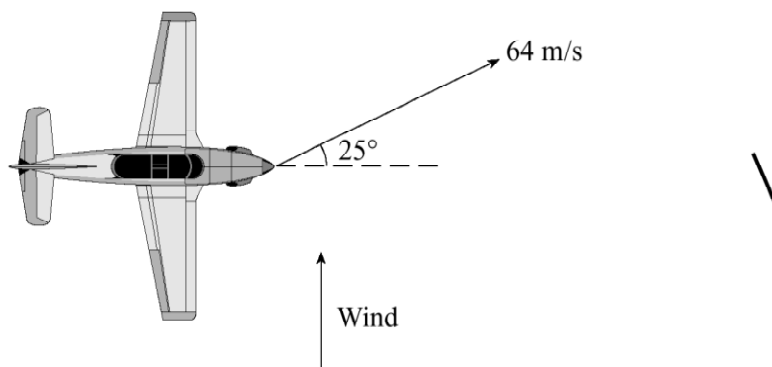

The resultant velocity of the aircraft over the ground is 64 m/s, 25° N of E . At what speed does the wind blow?

- A. 2.6 m/s
- B. 27 m/s
- C. 30 m/s
- D. 58 m/s

16. A soccer ball is kicked over level ground with an initial velocity of 18 m/s, 24° above the horizontal.

- a) How long does it take the ball to return to the ground? **(4 marks)**
- b) What is the range of the ball? **(3 marks)**

Physics 12  
Unit 1 Kinematics

9608

17.

An airplane which was flying eastward is later flying southward at the same speed. Which vector shows the airplane's **change** in velocity?

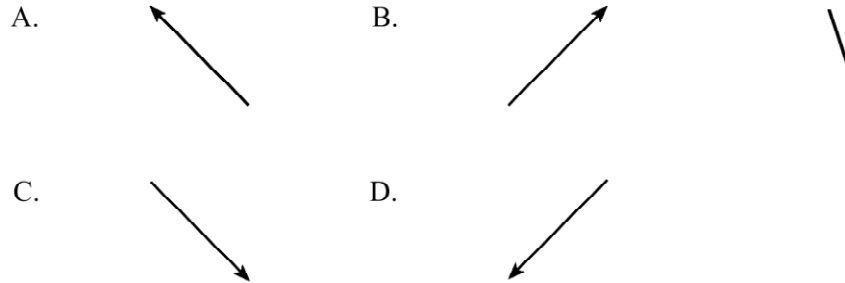

18.

At  $t = 0$  s a ball rolls off the edge of a vertical cliff. At  $t = 2.0$  s the ball is 6.0 m from the cliff as shown.

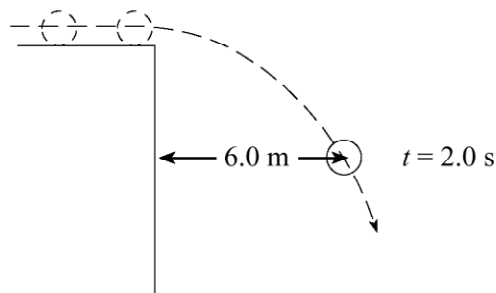

How far is the ball from the cliff at  $t = 4.0$  s?

- A. 6.0 m
- B. 9.0 m
- C. 12 m
- D. 24 m

9701

19.

Which of the following statements concerning vector and scalar quantities is **incorrect**?

- A. All scalar quantities have direction.
- B. All vector quantities have direction.
- C. All scalar quantities have magnitude.
- D. All vector quantities have magnitude.

20.

Two forces act on an object as shown in the diagram.

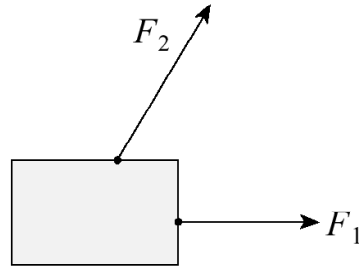

Which of the following **best** shows the resultant  $R$  of these forces?

A.

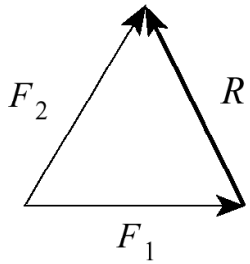

B.

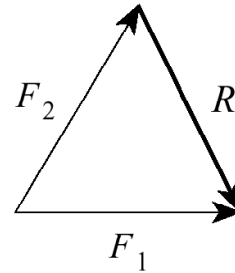

C.

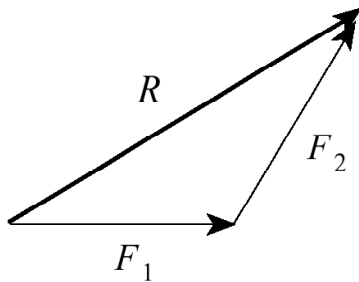

D.

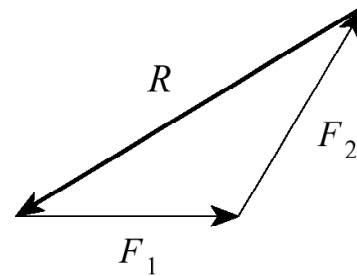

21. Starting from rest, a jet takes 25 s and needs 1 500 m of runway to become airborne. What is its speed when it leaves the ground?

- A. 60 m/s    B. 120 m/s    C. 250 m/s    D. 1500 m/s



Physics 12  
Unit 1 Kinematics

22. A projectile is launched over level ground at 85 m/s,  $25^\circ$  above the horizontal. Ignore air resistance.

a) Calculate the range of the projectile. **(5 marks)**

b) Using principles of physics, comment on the horizontal and vertical components of the projectile's velocity and acceleration during the flight. **(4 marks)**

---

---

---

---

---

---

---

---

---

---

9706

23.

When a 2.0 kg rock is dropped from a cliff it hits the beach at 24 m/s. At what speed would a 4.0 kg rock, dropped from the same cliff, hit the beach? Ignore friction.

- A. 12 m/s
- B. 24 m/s
- C. 34 m/s
- D. 48 m/s

Physics 12  
Unit 1 Kinematics

24.

Pamela swims at 2.8 m/s relative to the water, heading west. The current flows south at 1.2 m/s. Find Pamela's resultant direction.

- A. 23° S of W
- B. 25° S of W
- C. 23° N of W
- D. 25° N of W

25.

Mike runs horizontally off a cliff at 6.5 m/s and lands in the water 15 m from the base of the cliff.

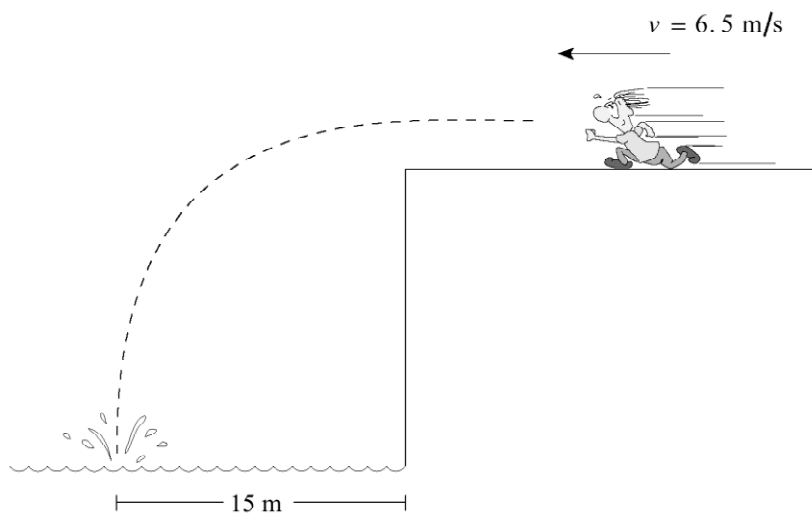

a) How long does it take Mike to hit the water?

**(3 marks)**

b) How high is the cliff?

**(4 marks)**

9708  
26.

The projectile shown below has an acceleration which is

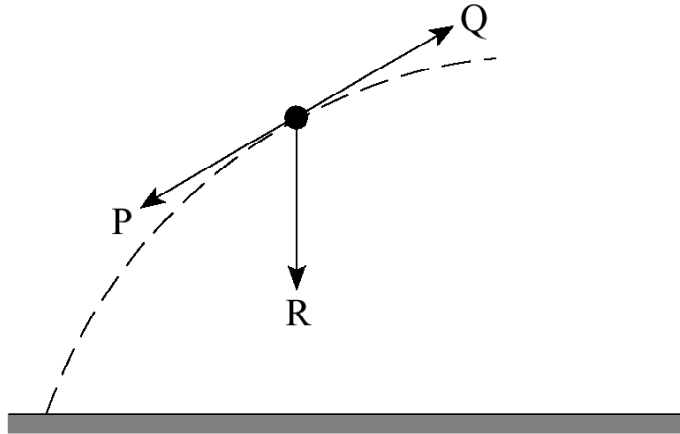

- A. zero.
- B. in the direction of P.
- C. in the direction of Q.
- D. in the direction of R.

27.

An object is launched at  $65^\circ$  to the horizontal with an initial speed of 25 m/s. What is the maximum height reached by this object?

- A. 5.7 m
- B. 26 m
- C. 32 m
- D. 150 m

9806

28.

A ball is kicked into the air from the surface of a playing field. If friction is negligible, the ball will follow a path that is

- A. circular.
- B. elliptical.
- C. parabolic.
- D. hyperbolic.

Physics 12  
Unit 1 Kinematics

29.

A rock is thrown from ground level at  $18 \text{ m/s}$ ,  $25^\circ$  above horizontal. What are the vertical and horizontal components of its launch velocity?

	VERTICAL COMPONENT	HORIZONTAL COMPONENT
A.	$16 \text{ m/s}$	$7.6 \text{ m/s}$
B.	$7.6 \text{ m/s}$	$16 \text{ m/s}$
C.	$20 \text{ m/s}$	$9.3 \text{ m/s}$
D.	$9.3 \text{ m/s}$	$20 \text{ m/s}$

30

A motorcycle accelerates uniformly from  $12 \text{ m/s}$  to  $30 \text{ m/s}$  while travelling  $420 \text{ m}$ . Its acceleration is

- A.  $0.043 \text{ m/s}^2$
- B.  $0.050 \text{ m/s}^2$
- C.  $0.10 \text{ m/s}^2$
- D.  $0.90 \text{ m/s}^2$

9808

31.

A rock is thrown from a clifftop at  $18 \text{ m/s}$ ,  $25^\circ$  above the horizontal. It lands on the beach  $4.2 \text{ s}$  later.

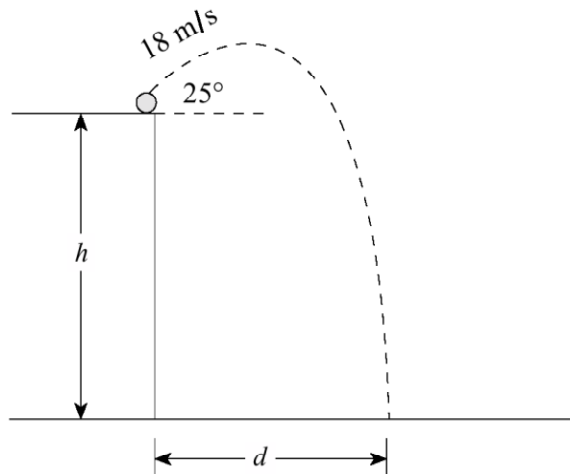

a) What is the height  $h$  of the cliff? (4 marks)

b) How far from the base of the cliff  $d$  did the rock land? (3 marks)

Physics 12  
Unit 1 Kinematics

9901  
32.

A student collects data from the path of a projectile similar to that shown in the diagram.

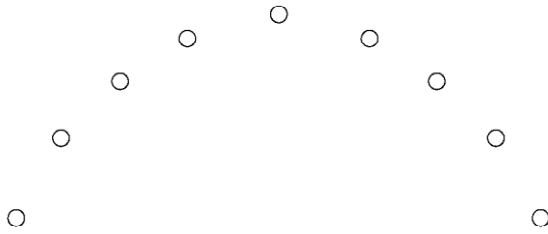

The student records the following data for horizontal displacement from the initial launch position as a function of time.

$d_x$ (cm)	0.0	0.5	0.9	1.5	1.9	2.5	3.1
$t$ (s)	0.000	0.020	0.040	0.060	0.080	0.100	0.120

a) Plot a graph of  $d_x$  vs.  $t$  on the graph below. **(2 marks)**

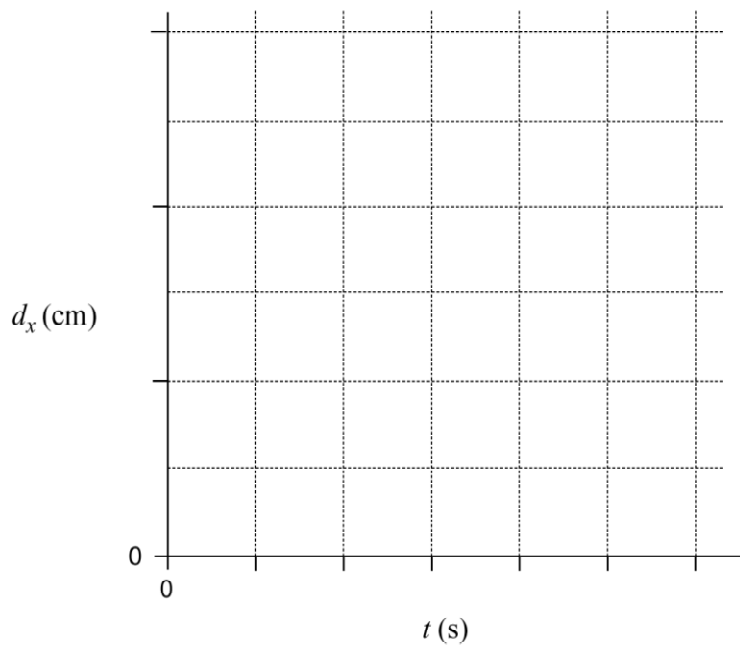

b) Calculate the slope of the line, giving your answer in appropriate units. **(2 marks)**

c) Based on this data and this graph, make a statement about projectiles. **(1 mark)**

Physics 12  
Unit 1 Kinematics

33. Scholarship question: A 0.50 kg ball is thrown at  $42^\circ$  above the horizontal at 19 m/s from the hot air balloon when the balloon is 25 m above the ground. **The balloon is traveling upwards at a constant velocity of 3.5 m/s.**

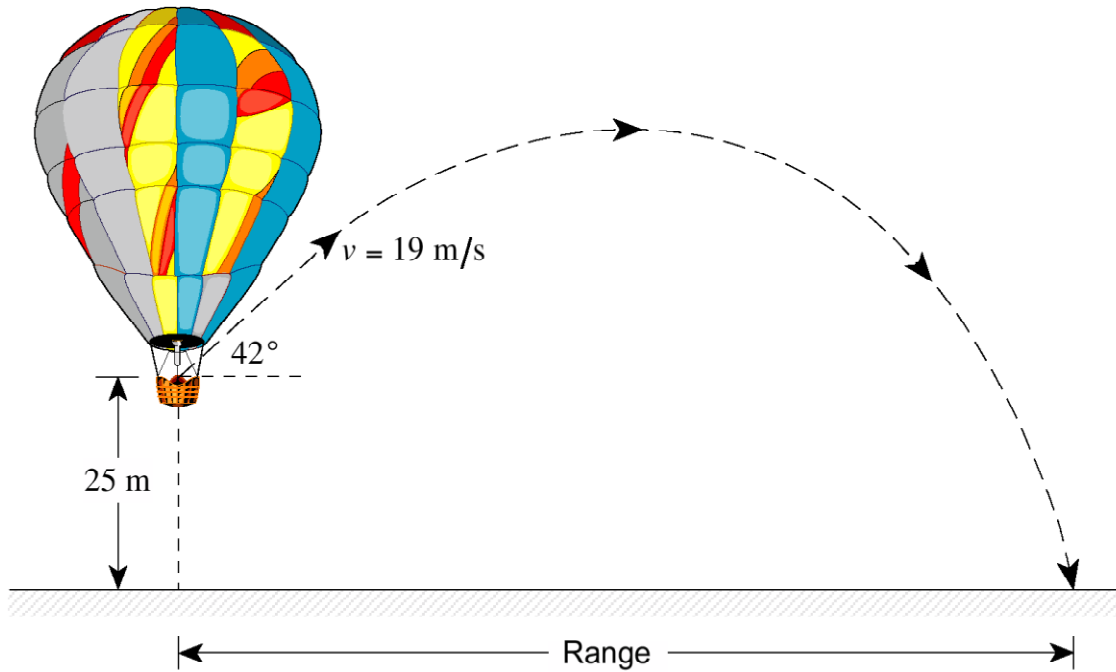

What is the range?

(10 marks)

Physics 12  
Unit 1 Kinematics

0006

34.

Which of the following graphs best illustrates the horizontal displacement of a projectile as a function of time? Ignore friction.

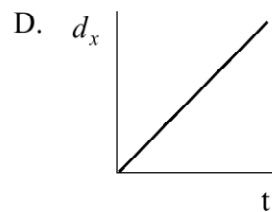
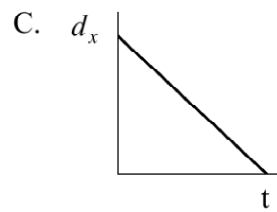
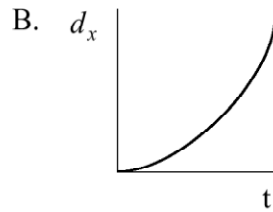
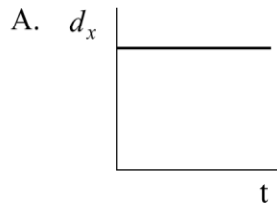

0206

35.

A projectile is launched towards a wall as shown in the diagram below.

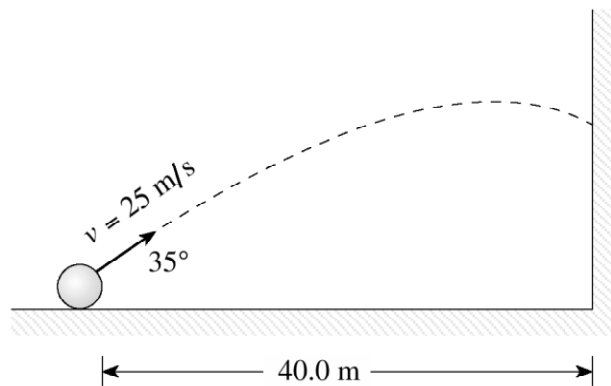

With what velocity (magnitude and direction) does the projectile hit the wall?

**(7 marks)**

Physics 12  
Unit 1 Kinematics

Answers:

1. d
2. a
3. a) 3.18 m b) 16.2 m/s
4. c
5. a
6. b
7.
  - The horizontal velocity component is constant. **1 mark**
  - The vertical velocity component constantly changes. **1 mark**
  - This vertical acceleration is caused by the force of gravity. **1 mark**
  - The downward direction of the change in velocity / acceleration / force must be mentioned. **1 mark**
8. b
9. a) 2.9 s b) 34 m/s @ 18° below the horizontal
10. c
11. d
12. b
13. a) 3.5 m/s b) 33 s
14. c
15. b
16. a)  $t = 1.49$  s b) 25 m
17. d
18. c
19. a
20. c
21. b
22. a)  $5.6 \times 10^2$  m  
b)
  - The horizontal component of velocity remains constant. There is no horizontal acceleration (assuming air resistance is negligible). ← 2 marks
  - The vertical component of velocity changes continuously during the flight. ← 1 mark
  - The vertical acceleration is constant at  $9.8 \text{ m/s}^2$ , downward, throughout the flight. ← 1 mark
23. b
24. a
25. a) 2.3 s b) 26 m
26. d
27. b
28. c
29. b
30. d
31. a)  $h = 54$  m b) range = 69 m
32. b) 25 cm/s. The slope is horizontal velocity  
c) Since the slope is constant, the horizontal velocity of projectiles is constant
33. 62.8 m
34. d
35. 21 m/s @ 13° below the horizontal



Physics 12  
Unit 1 Kinematics

Note to teachers: The 4 numbers that occasionally appear above a group of questions (ie 9606) tell you which provincial exam I took the questions from. Feel free to use these in any way you wish. If you find any errors in the answer key, or if you have any questions, please email me at [kdueck@sd42.ca](mailto:kdueck@sd42.ca).

Kelvin Dueck  
Pitt Meadows Secondary School